

# Genehmigungszeichnung / Approval Drawing

Technische Daten / technical data

Nenndrehmoment / rated torque of coupling  
 Stoßdrehmoment / shock torque of coupling  
 Drehsteifigkeit dyn. / Torsional rigidity dyn.  
 Gesamtgewicht / overall weight  
 Massenträgheitsmoment / Mass moment of inertia  
 max. Drehzahl / max. speed  
 max. Versatz axial / max. axial misalignment  
 max. Versatz radial / max. radial misalign  
 max. Winkelversatz / max. angular misalign  
 Summe der Verlagerungen / sum misalign

$T_{KN} = 40 \text{ Nm}$   
 $T_{KS} = 40 \text{ Nm}$   
 $C_{T \text{ dyn.}} = 9000 \text{ Nm/rad}$   
 $m_{\text{ges}} = 0.23 \text{ kg}$   
 $I_{\text{ges}} = 0.000103 \text{ kgm}^2$   
 $n_{\text{max}} = 8000 \text{ 1/min}$   
 $\Delta K_a = 0.6 \text{ mm}$   
 $\Delta K_r = 0.4 \text{ mm}$   
 $\Delta K_w = 3.0^\circ$   
 $\Delta K \leq 100 \%$

Schraubenanzugsmoment / screw tightening torque T

$A = 14 \text{ Nm} \pm 5\%$

smartflex Size 1  
 Type 932.333  
 long bellow (8 windings)  
 bushing 1  
 bore: 20 mm  
 fit: H7  
 bushing 2  
 bore: 25 mm  
 fit: H7

Nominal torque 40 Nm  
 Friction type transmittable torque of shaft/hub connection;  
 Bushing 1 max. 40 Nm with bore H7 / shaft h6 or comparable fitting tolerance.  
 Bushing 2 max. 40 Nm with bore H7 / shaft h6 or comparable fitting tolerance.

**for Nicola Torquati**  
**23.01.2018, Nicola Torquati**

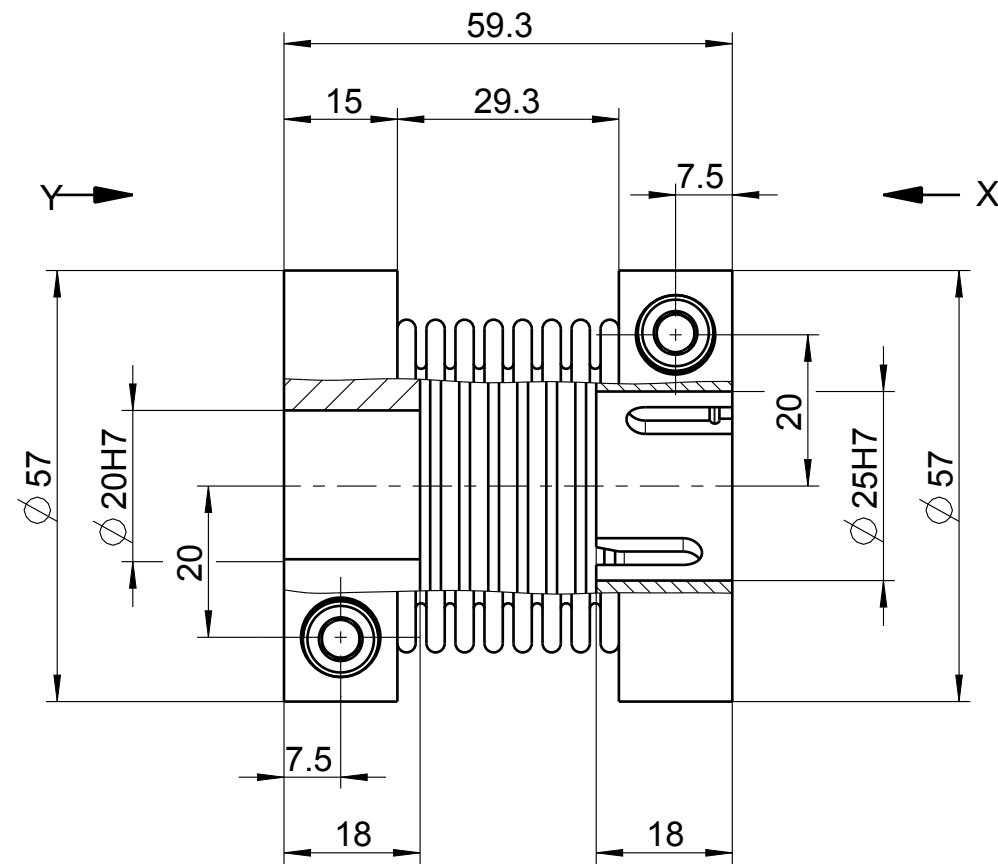

Ansicht / view X

Ansicht / view Y

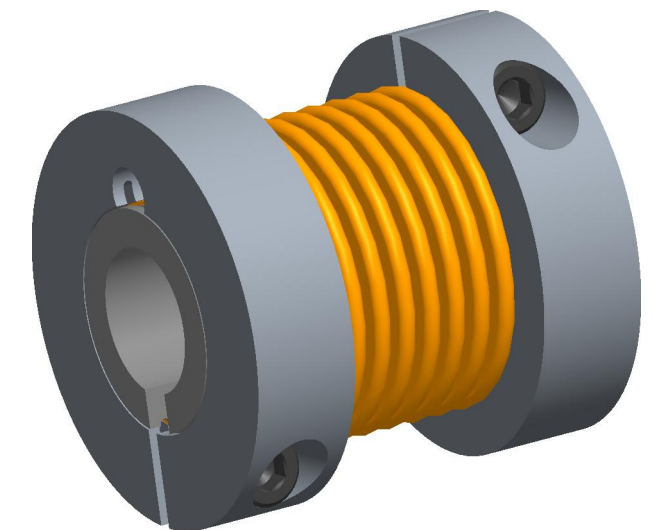
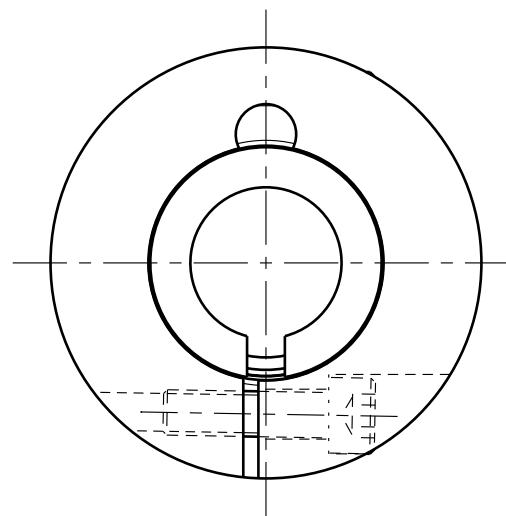
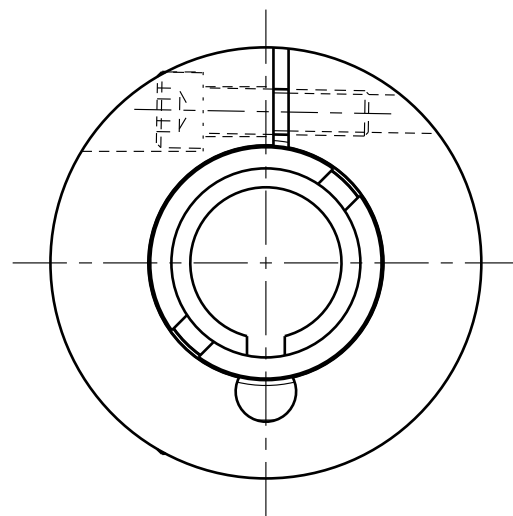

Weitergabe sowie Vervielfältigung dieses Dokuments, Verwertung und Mitteilung seines Inhalts sind verboten, soweit nicht ausdrücklich gestattet. Zuwiderhandlungen verpflichten zu Schadenersatz. Alle Rechte für den Fall der Patent-, Gebrauchsmuster- oder Geschmacksmustereintragung vorbehalten.

The reproduction, distribution and utilization of this document as well as the communication of its contents to others without explicit authorization is prohibited. Offenders will be held liable for the payment of damages. All rights reserved in the event of the grant of a patent, utility model or design.

		Datum / date	Name / name				 Chr. Mayr GmbH + Co. KG
erstellt generate		23.01.2018	TORQUATI				
Benennung / part name							Artikelnummer / part number
smartflex Size 1							7001493
Maßstab scale	Type type	932.333	Größe size	1	Gewicht weight	0.23 kg	
1:1	Kunde customer	Nicola Torquati					