



PROFIBUS®

E94AYCPM

Servo Drives 9400 -----

Communication Manual EN

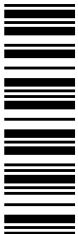

13422195

Contents

1	About this documentation	5
1.1	Conventions used	7
1.2	Terminology used	8
1.3	Definition of the notes used	9
2	Safety instructions	10
2.1	General safety and application instructions	10
2.2	Device- and application-specific safety instructions	11
2.3	Residual hazards	11
3	Product description	12
3.1	Application as directed	12
3.2	Identification	12
3.3	Features	13
3.4	Terminals and interfaces	14
4	Technical data	15
4.1	General data and operating conditions	15
4.2	Protective insulation	16
4.3	Protocol data	19
4.4	Communication time	19
4.5	Dimensions	20
5	Installation	21
5.1	Mechanical installation	22
5.1.1	Mounting	22
5.1.2	Dismounting	22
5.2	Electrical installation	23
5.2.1	Network topology	23
5.2.2	Activating the bus terminating resistor	25
5.2.3	Bus cable specification	26
5.2.4	PROFIBUS connection	27
5.2.5	External voltage supply	28
6	Commissioning	29
6.1	Before initial switch-on	29
6.2	Configuration of the host (master)	30
6.3	Possible DIP switch settings	31
6.3.1	Setting the station address	31
6.3.2	Establishing EMF2133IB compatibility	32
6.4	First switch-on	33
6.5	Going online with »Engineer« via TCI	34
7	Data transfer	43
8	Process data transfer	44

Contents

9	Parameter data transfer	47
9.1	Addressing of the parameter data	47
9.2	DRIVECOM parameter data channel (DP-V0)	48
9.2.1	Telegram structure (overview)	48
9.2.2	Byte 1: Service	49
9.2.2.1	Reading parameter data from the controller	50
9.2.2.2	Writing parameter data to the controller	50
9.2.2.3	Abort of data transfer by the controller	51
9.2.2.4	Data transfer abort by the master	51
9.2.3	Byte 2: Subindex	52
9.2.4	Bytes 3 + 4: Index	52
9.2.5	Bytes 5 ... 8: Parameter value / error information	53
9.2.6	Error codes	54
9.2.7	Telegram examples	55
9.2.7.1	Read request: Querying the heatsink temperature	55
9.2.7.2	Write request: Setting the deceleration time for quick stop (QSP)	56
9.3	PROFIdrive parameter data channel (DP-V1)	57
9.3.1	Connection establishment between master and slave	58
9.3.2	Acyclic data transfer	59
9.3.3	Telegram structure	60
9.3.3.1	Reading parameter data from the controller	61
9.3.3.2	Response to a correctly executed read request	62
9.3.3.3	Response to a read error	64
9.3.3.4	Writing parameter data to the controller	66
9.3.3.5	Response to a correctly executed write request	68
9.3.3.6	Response to a write error	69
9.3.4	Error codes	70
9.3.5	Telegram examples	72
9.3.5.1	Read request: Querying the heatsink temperature	72
9.3.5.2	Write request: Setting the deceleration time for quick stop (QSP)	74
9.4	Consistent parameter data	76
10	PROFIsafe	77
11	Monitoring	78
11.1	Permanent interruption of PROFIBUS communication	78
11.2	Short-time interruption of PROFIBUS communication	79
11.3	Settings and displays in the »Engineer«	80
11.4	Interruption of internal communication	81
12	Diagnostics	82
12.1	LED status displays	82
12.2	Diagnostics with the »Engineer«	83
12.3	Advanced diagnostic message	85
12.3.1	Example 1: Error in parameter data "Incorrect PROFIsafe target address"	86
12.3.2	Example 2: Error "Undervoltage in the DC bus" in the Servo Drive 9400	86
13	Error messages	87
13.1	Short overview of the PROFIBUS error messages	87
13.2	Possible causes and remedies	88

Contents

14	Parameter reference	91
14.1	Communication-relevant parameters of the standard device	91
14.2	Parameters of the communication module for slot MXI1	93
14.3	Parameters of the communication module for slot MXI2	102
14.4	Table of attributes	111
14.5	Implemented PROFIdrive objects (DP-V1)	114
15	DIP switch positions for setting the station address	116
	Index	120
	Your opinion is important to us	124

1 About this documentation

1 About this documentation

This documentation exclusively describes the communication module E94AYCPM (PROFIBUS).



Note!

This documentation supplements the **Mounting Instructions** supplied with the communication module and the "**Servo Drives 9400**" **Hardware Manual**.

The Mounting Instructions contain safety instructions which must be observed!

The features and functions of the communication module are described in detail.

Typical applications are explained with the help of examples.

The theoretical connections are only explained in so far as they are necessary for comprehending the function of the communication module.

This documentation does not describe the software of other manufacturers. No responsibility is taken for corresponding information given in this documentation. Information on how to use the software can be obtained from the documents of the host system (master).

All brand names used in this documentation are trademarks of their respective owners.



Tip!

Detailed information about PROFIBUS can be found on the website of the PROFIBUS & PROFINET user organisation:

www.profibus.com

1 About this documentation

Target group

This documentation is intended for all persons who plan, install, commission and maintain the networking and remote servicing of a machine.



Tip!

Current documentation and software updates with regard to Lenze products can be found in the download area at:

www.Lenze.com

Validity information

The information given in this documentation is valid for the following devices:

Extension module	Type designation	From hardware version	From software version
PROFIBUS communication module	E94AYCPM	1A	01.11

Screenshots/application examples



All screenshots in this documentation are application examples. Depending on the firmware version of the communication module and the software version of the Engineering tools installed (»Engineer«, »STEP7«), the screenshots in this documentation may differ from the actual screen display.

1 About this documentation

1.1 Conventions used

1.1 Conventions used

This manual uses the following conventions to distinguish between different types of information:

Type of information	Writing	Examples/notes
Numbers		
Decimal separator	Point	The decimal point is always used. Example: 1234.56
Hexadecimal	0x[0 ... 9, A ... F]	Example: 0x60F4
Binary • Nibble	In inverted commas Point	Example: '100' Example: '0110.0100'
Text		
Version information	Text colour blue	All pieces of information that only apply to or from a specific software version of the controller are highlighted accordingly in this documentation. Example: This function extension is available from software version V3.0!
Program name	» «	The Lenze PC software »Engineer«...
Window	<i>italics</i>	The <i>message window</i> ... / The <i>Options</i> dialog box ...
Variable name		Setting <i>bEnable</i> to TRUE...
Control element	Bold	The OK button ... / The Copy command ... / The Properties tab ... / The Name input field ...
Sequence of menu commands		If several successive commands are required for executing a function, the individual commands are separated from each other by an arrow: Select the command File → Open to...
Hyperlink	<u>Underlined</u>	Optically highlighted reference to another topic. Can be activated with a mouse-click in this online documentation.
Symbols		
Page reference	 8	Optically highlighted reference to another page. Can be activated with a mouse-click in this online documentation.
Step-by-step instructions		Step-by-step instructions are indicated by a pictograph.

1 About this documentation

1.2 Terminology used

1.2 Terminology used

Term	Meaning
Controller	Lenze controller of the "Servo Drives 9400" product range
Standard device	
HW	Hardware
Lenze setting	Settings with which the device is preconfigured ex works.
Basic setting	
GSD / GSE	Device data base file (device description for PROFIBUS nodes)
	PROFIBUS® (Process Field Bus) is a widely-used fieldbus system for the automation of machines and production plants. PROFIBUS® is a registered trademark and patented technology licensed by the PROFIBUS & PROFINET International (PI) user organisation.
PDO	Process data object
PLC	Programmable Logic Controller
»STEP7«	Siemens software for programming and configuring PROFIBUS Siemens control systems
SW	Software
TCI	Tool Calling Interface

1 About this documentation

1.3 Definition of the notes used

1.3 Definition of the notes used

The following signal words and symbols are used in this documentation to indicate dangers and important information:

Safety instructions

Structure of the safety instructions:



Danger!

(characterises the type and severity of danger)

Note

(describes the danger and informs how to prevent dangerous situations)

Pictograph	Signal word	Meaning
	Danger!	Danger of personal injury through dangerous electrical voltage Reference to an imminent danger that may result in death or serious personal injury if the corresponding measures are not taken.
	Danger!	Danger of personal injury through a general source of danger Reference to an imminent danger that may result in death or serious personal injury if the corresponding measures are not taken.
	Stop!	Danger of property damage Reference to a possible danger that may result in property damage if the corresponding measures are not taken.

Application notes

Pictograph	Signal word	Meaning
	Note!	Important note to ensure trouble-free operation
	Tip!	Useful tip for easy handling
		Reference to other documents

2 Safety instructions



Note!

Always observe the specified safety measures to avoid severe injury to persons and damage to property!

Always keep this documentation to hand in the vicinity of the product during operation.

2.1 General safety and application instructions



Danger!

If you disregard the following basic safety measures, this can cause severe injury to persons and damage to material assets.

Lenze drive and automation components ...

- must only be used as directed.
 - ▶ [Application as directed](#) (12)
- must never be commissioned in the event of visible damage.
- must never be technically modified.
- must never be commissioned before they have been completely mounted.
- must never be operated without the covers required.
- can - depending on their degree of protection - have live, moving or rotating parts during and after operation. Surfaces can be hot.

For Lenze drive components ...

- use only the accessories approved.
- use only original spare parts from the manufacturer.

Observe all specifications given in the attached and associated documentation.

- This is the precondition for safe and trouble-free operation and for obtaining the product features specified.
 - ▶ [Features](#) (13)
- The procedural notes and circuit details described in this document are only proposals. It is up to the user to check whether they can be adapted to the particular applications. Lenze does not take any responsibility for the suitability of the procedures and circuit proposals described.

Only qualified personnel may work with and on Lenze drive and automation components. According to IEC 60364 and CENELEC HD 384, these are persons ...

- who are familiar with the installation, assembly, commissioning and operation of the product.
- who have the corresponding qualifications for their work.
- who know all regulations for the prevention of accidents, directives and laws applicable on site and are able to apply them.

2 Safety instructions

2.2 Device- and application-specific safety instructions

2.2 Device- and application-specific safety instructions

- During operation, the communication module must be firmly connected to the standard device.
- With external voltage supply, always use a separate power supply unit, safely separated to EN 61800-5-1 in every control cabinet (SELV / PELV).
- Only use cables corresponding to the given specifications.
 - ▶ [Bus cable specification](#) (📖 26)



Documentation for the standard device, control system, plant/machine

All other measures prescribed in this documentation must also be implemented.
Observe the safety instructions and application notes specified in the documentation.

2.3 Residual hazards

Protection of persons

If the Servo Drives 9400 are operated on a phase earthed mains with a rated mains voltage ≥ 400 V, external measures need to be implemented in order to ensure protection against accidental contact.

- ▶ [Protective insulation](#) (📖 16)

Device protection

The communication module contains electronic components which may be damaged or destroyed by electrostatic discharge.

- ▶ [Installation](#) (📖 21)

3 Product description

3.1 Application as directed

3 Product description

3.1 Application as directed

The communication module ...

- is an accessory module for use in conjunction with the following Lenze standard devices:

Product series	Type designation	From hardware version	From software version
Servo Drives 9400	E94AxxExxxx	1A	01.35
Servo Drives 9400 PLC	E94AxPExxxx	VA	02.00
Regenerative power supply module	E94ARNxxxx	VA	01.00

- is a device intended for use in industrial power systems.
- is only to be operated under the operating conditions specified in this documentation.
- may only be used in PROFIBUS networks.

Any other use shall be deemed inappropriate!

3.2 Identification

The type designation as well as the hardware and software version of the communication module are indicated on the nameplate:

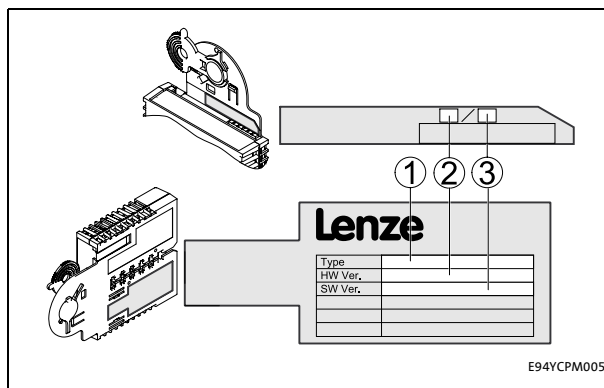

1 Type designation (type)

E94 Product series

A Version

Y Module identification: extension module

C Module type: communication module

PM PROFIBUS

2 Hardware version (HW)

3 Software version (SW)

[3-1] Nameplate

3.3 Features

- Interface module for the PROFIBUS communication system to be connected to the expansion slots of the Servo Drives 9400
- Support of parameter data channels DRIVECOM (DP-V0) and PROFIDrive (DP-V1)
- Transfer of safe information via the PROFIsafe protocol if an SM301 safety module (E94AYAE) is used simultaneously
- A maximum of 32 process data words per direction can be exchanged.
- The communication module can either be supplied internally by the Servo Drive 9400 or externally by a separate voltage source.
- Bus coupling via remote bus according to the RS485 standard
- Automatic detection of the baud rate (9.6 kbps to 12 Mbps)
- Setting of the station address is possible via DIP switch or code.
- Software compatibility with the EMF2133IB communication module
- Access to all Lenze parameters

3 Product description

3.4 Terminals and interfaces

3.4 Terminals and interfaces

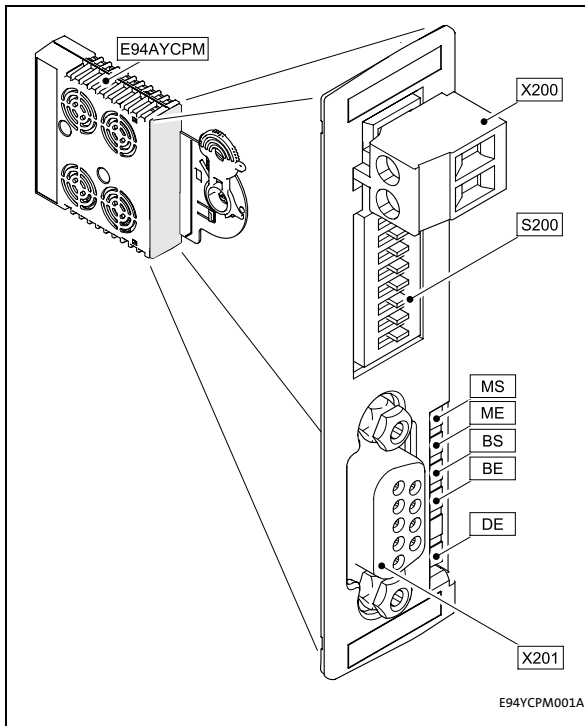

X200 2-pin plug connector with screw connection for external voltage supply

▶ [External voltage supply](#) (📖 28)

S200 DIP switches for setting the ...

- Station address
- compatibility with the EMF21331B communication module

▶ [Possible DIP switch settings](#) (📖 31)

X201 PROFIBUS connection:

9-pin Sub-D socket

▶ [PROFIBUS connection](#) (📖 27)

MS 5 LED status displays for diagnostic purposes

ME ▶ [LED status displays](#) (📖 82)

BS

BE

DE

[3-2] E94AYCPM communication module (PROFIBUS)

4 Technical data



"Servo Drives 9400" Hardware Manual

Here you can find the **ambient conditions** and information on the **electromagnetic compatibility (EMC)** which also apply to the communication module.

4.1 General data and operating conditions

Area	Values
Order designation	E94AYCPM
Communication profile	<ul style="list-style-type: none"> • PROFIBUS DP-V0 (DRIVECOM) • PROFIBUS DP-V1 (PROFIdrive)
Communication medium	RS485
Interface	9-pin Sub-D socket
Network topology	<ul style="list-style-type: none"> • Line (without repeater) • Tree/line (with repeater)
Bus device type	PROFIBUS slave
Number of slaves	<ul style="list-style-type: none"> • Max. 31 (without repeater) • Max. 125 (with repeater)
Max. cable length	1200 m (depending on the selected baud rate and the cable type used)
PNO identification number	0x07A8
Baud rate for cable type A (EN 50170)	9.6 kbps ... 12 Mbps (automatic detection)
Voltage supply	External supply via the 2-pin plug connector <ul style="list-style-type: none"> • Terminal "+": U = 24 V DC (20.4 V - 0 % ... 28.8 V + 0 %), I = 130 mA • Terminal "-": Reference potential for external voltage supply
Conformities, approvals	<ul style="list-style-type: none"> • CE • UL

4.2 Protective insulation



Danger!

Dangerous voltage

If the Servo Drives 9400 are operated on a phase earthed mains with a rated mains voltage ≥ 400 V, external measures need to be implemented in order to ensure protection against accidental contact.

Possible consequences:

Death or severe injury

Protective measures:

If protection against accidental contact is required for the control terminals of the controller and the terminals of the plugged-in device modules, ...

- a double isolating distance must be provided.
- the components to be connected must be provided with a second isolating distance.



Note!

The existing protective insulation in the Servo Drives 9400 is implemented according to EN 61800-5-1.

4 Technical data

4.2 Protective insulation

The following illustration ...

- shows the arrangement of the terminal strips and the separate potential areas of the Servo Drive 9400.
- serves to determine the decisive protective insulation between two terminals located in differently insulated separate potential areas.

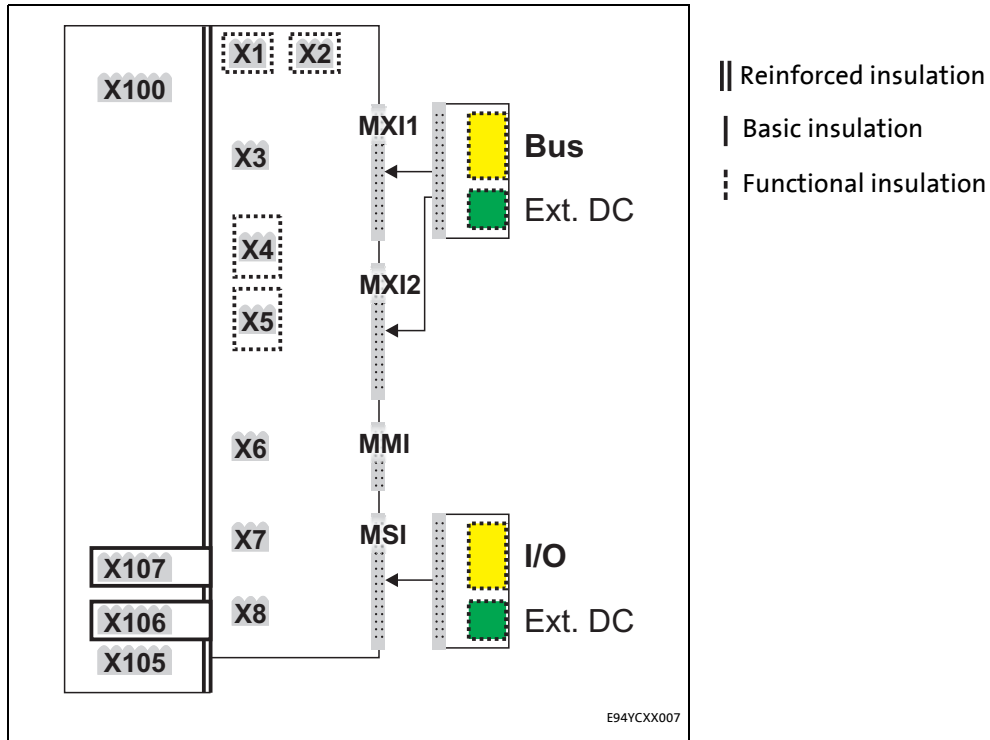

[4-1] Protective insulation in accordance with EN61800-5-1

Terminal strip	Connection	Terminal strip	Connection
X100	L1, L2, L3 (Single Drive only)	X1	CAN on board 9400
	+UG, -UG	X2	State bus 24 V (ext.)
X105	U, V, W	X3	Analog inputs/outputs
	Rb1, Rb2 (Single Drive only)	X4	Digital outputs
X106	Motor PTC	X5	Digital inputs
X107	Control of the motor holding brake	X6	Diagnostics
		X7	Resolver
		X8	Encoder
		MXI1, MXI2	Extension module
		MMI	Memory module
		MSI	Safety module

Example

Which type of protective insulation is used between the bus terminal of the device module in slot MXI1 or MXI2 and the mains terminal X100?

The separate potential area with the better protective insulation is decisive.

- The separate potential area of the device module's bus terminal is "functionally insulated".
- The separate potential area of the mains terminal has a "reinforced insulation".

Result: The insulation between the mains terminal X100 and the bus terminal is of the "reinforced insulation" type.

4 Technical data

4.3 Protocol data

4.3 Protocol data

Area	Values
Process data words (PCD)	1 ... 32 words (16 bits/word)
Cyclic parameter data channel (DP-V0)	4 words
Acyclic parameter data channel (DP-V1)	Max. 240 bytes
Safety data	4 words
PROFIBUS user data length	1 ... 32 words (process data) + 4 words (parameter data or safety data)

4.4 Communication time

The communication time is the time between the start of a request and the arrival of the corresponding response.

The communication times in a PROFIBUS network depend on ...

- the processing time in the controller;
- the transmission delay time (baud rate / telegram length);
- the nesting depth of the network.

Processing time in the controller

Data	Processing time
Process data	Approx. 4 ms update cycle + 0 ... 1 ms processing time in the module + 1 ... x ms application task runtime of the technology application used (tolerance)
Parameter data	Approx. 30 ms + 20 ms tolerance (typical) For some codes, the processing time may be longer (see software manual/online help for the Servo Drive 9400).

There are no interdependencies between parameter data and process data.

4 Technical data

4.5 Dimensions

4.5 Dimensions

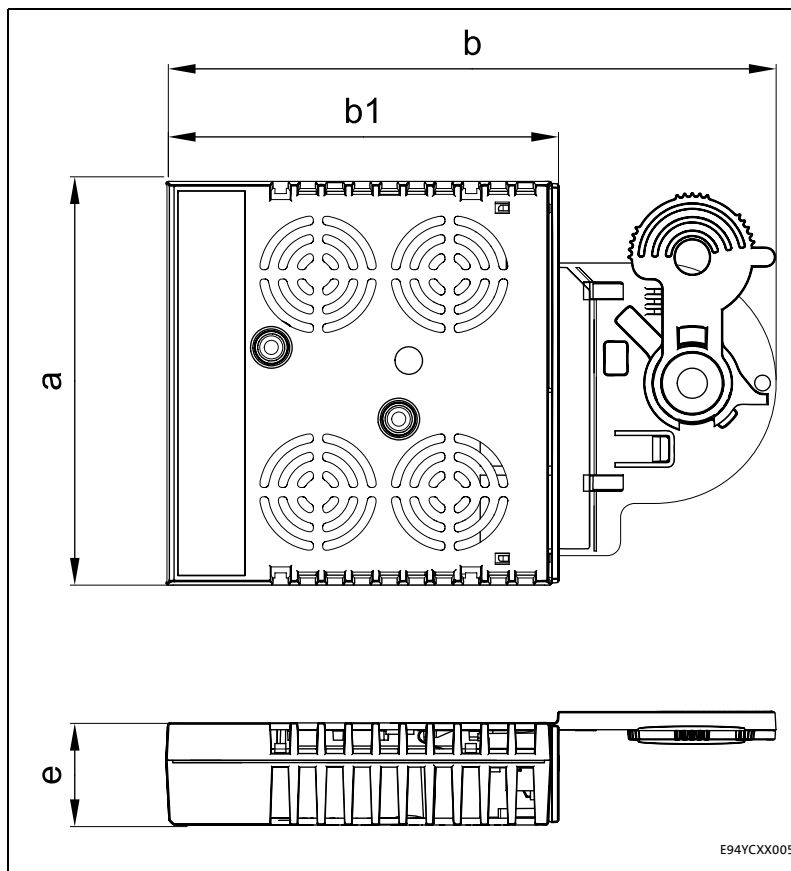

- a 89 mm
- b 134 mm
- b1 87 mm
- e 23 mm

[4-2] Dimensions

5 Installation



Stop!

Electrostatic discharge

Electronic components within the communication module can be damaged or destroyed by electrostatic discharge.

Possible consequences:

- The communication module is defective.
- Communication via the fieldbus is not possible or faulty.

Protective measures

Discharge electrostatic charges before touching the module.

5.1

Mechanical installation

**Note!**

A safety bus system (PROFIsafe) can only be operated via the upper module slot (MXI1) of the Servo Drive 9400.

5.1.1

Mounting

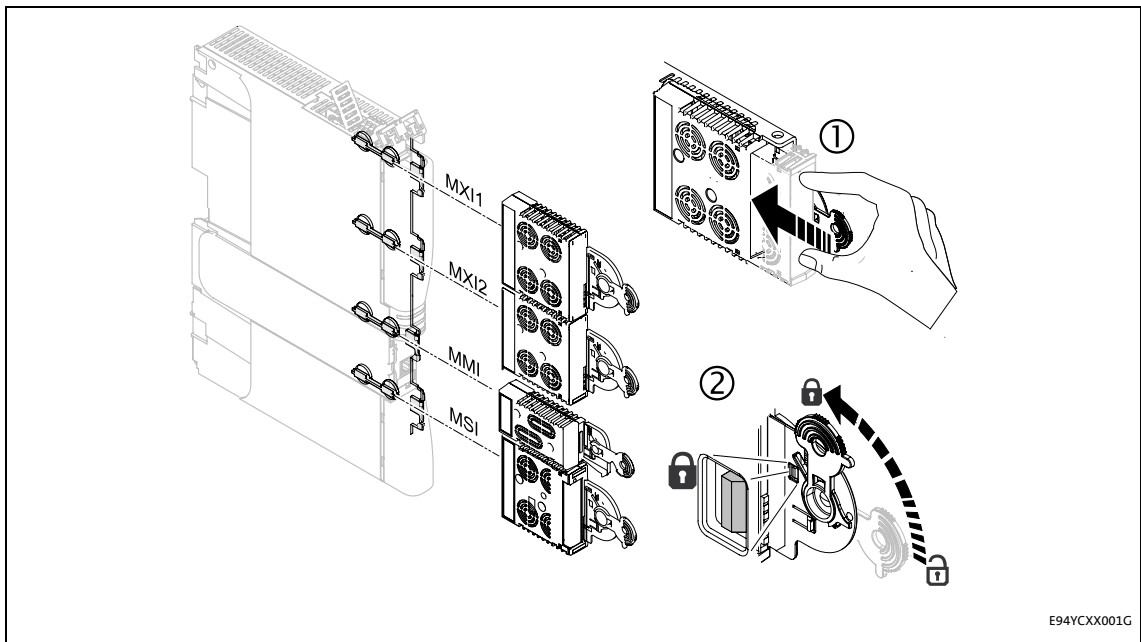

[5-1] Mounting

5.1.2

Dismounting

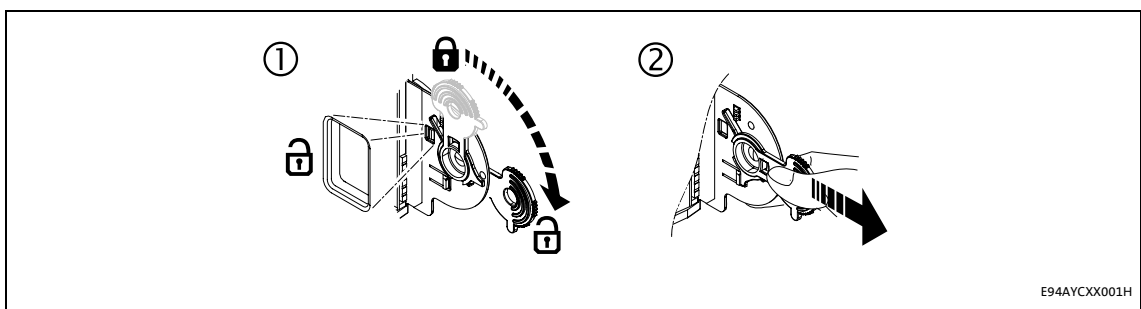

[5-2] Dismounting

5.2

Electrical installation



Documentation for the standard device, control system, plant/machine

Observe the notes and wiring instructions given in the documentation.

5.2.1

Network topology

The following examples show two simple RS485 networks.

Every segment of the network must be terminated at both ends. The bus terminators of the PROFIBUS are marked with a "Z" in the below examples.

In the case of an RS485 network of only one segment, the PROFIBUS master (M) with the integrated bus terminator starts the segment while the bus terminating resistor in the connector of the last PROFIBUS station (S) must be activated.

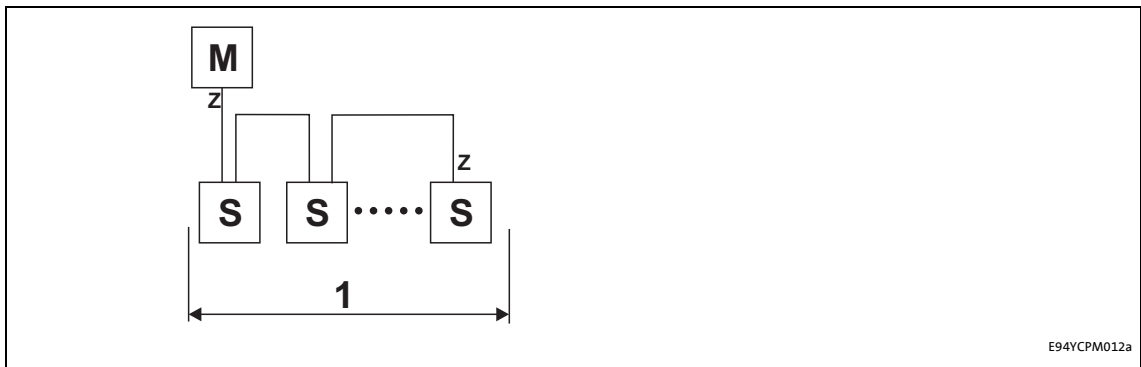

[5-3] RS485 network with one segment

An RS485 network consisting of several segments contains repeaters (R) for connecting the segments. The repeaters are provided with integrated bus terminating resistors.

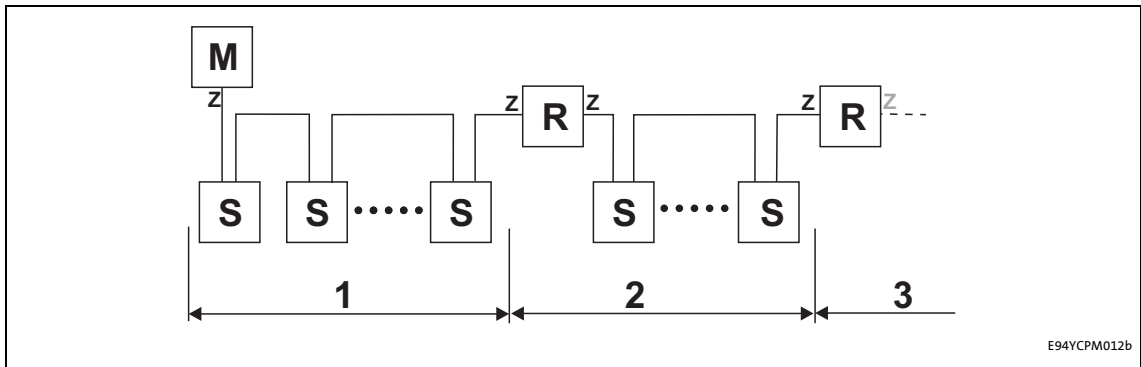

[5-4] RS485 network with a repeater

If no repeater is to be used at the end of the segment, the bus terminating resistor must be activated in the connector of the last device. The bus termination is supplied by the station itself.

If the communication module is supplied externally, the bus terminator can be supplied independently of the standard device supply.

▶ [External voltage supply](#) (☞ 28)



Note!

The bus terminator must always be supplied. Otherwise, the bus can get unstable.

▶ [Activating the bus terminating resistor](#) (☞ 25)

Number of stations

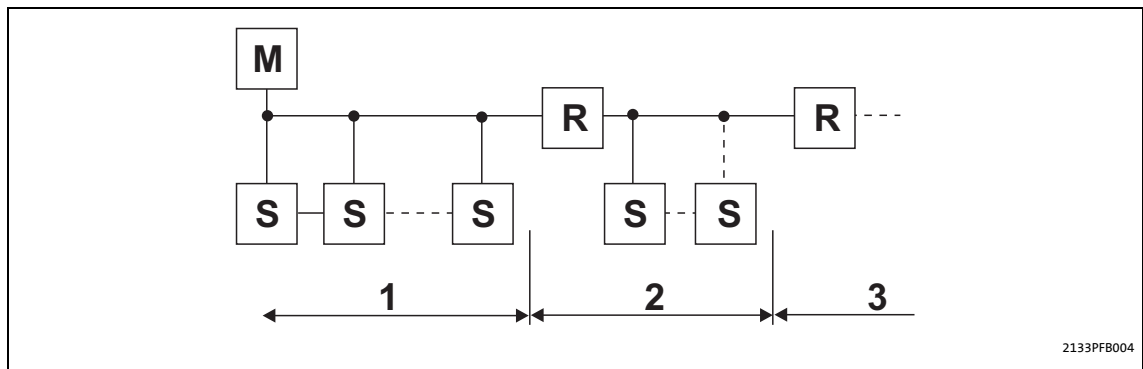

[5-5] Number of stations

Segment	Master (M)	Slave (S)	Repeater (R)
1	1	31	-
	2	30	-
2	-	30	1
3	-	30	1



Tip!

Repeaters do not have a station address. When calculating the maximum number of stations, they reduce the number of stations by 1 on each side of the segment.

Repeaters can be used to build up line and tree topologies. The maximum total bus system expansion depends on ...

- the baud rate used;
- the number of repeaters used.

5.2.2 Activating the bus terminating resistor

The PROFIBUS must be terminated by a bus terminating resistor at the first and last physical bus station.

The bus terminating resistor in the bus connector of the bus cable is activated by means of a switch. PROFIBUS cables with integrated bus terminating resistor are offered by several cable manufacturers.



Note!

If you want to disconnect individual bus stations, ensure that the bus terminators at the cable ends remain active.

Please observe that the bus termination is not active any longer if ...

- the bus connector has been disconnected;
- the voltage supply of the Servo Drive 9400 has been switched off;
- the [External voltage supply \(28\)](#) of the communication module has been switched off.

5.2.3 Bus cable specification



Note!

Only use cables which meet the listed specifications of the PROFIBUS user organisation.

Area	Values
Cable resistance	135 ... 165 Ω /km, (f = 3 ... 20 MHz)
Capacitance per unit length	\leq 30 nF/km
Loop resistance	< 110 Ω /km
Core diameter	> 0.64 mm
Core cross-section	> 0.34 mm ²
Cores	Twisted in pairs, insulated and shielded

Bus cable length

The length of the bus cable depends on the baud rate and cable type used. The data in the following table applies to PROFIBUS cables of "FC-Standard Cable" cable type .

Baud rate	Length
9.6 ... 93.75 kbps	1200 m
187.5 kbps	1000 m
500 kbps	400 m
1500 kbps	200 m
3000 ... 12000 kbps	100 m



Note!

The baud rate depending of the data volume, cycle time and number of stations should only be selected as high as required for the application.



Tip!

We recommend taking the use of optical fibres into consideration for high baud rates.

Advantages of optical fibres:

- External electromagnetic interferences have no effect on the transmission path.
- Bus lengths of several kilometres are also possible with higher baud rates.
- The bus length is ...
 - independent of the baud rate;
 - dependent on the optical fibre used.

5.2.4 PROFIBUS connection

The 9-pin Sub-D socket **X201** serves to connect the communication module to the bus system.

Assignment of the 9-pin Sub-D socket X201

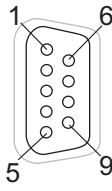
View	Pin	Assignment	Description
	1	Not assigned	-
	2	Not assigned	-
	3	RxD/TxD-P	Data line B (received data/transmitted data, plus)
	4	RTS	Request To Send (received data/transmitted data, no differential signal)
	5	M5V2	Data ground (ground to 5 V)
	6	P5V2	5 V DC / 30 mA (bus termination)
	7	Not assigned	-
	8	RxD/TxD-N	Data line A (received data/transmitted data, minus)
	9	Not assigned	-

5.2.5 External voltage supply



Note!

With external voltage supply, always use a separate power supply unit, safely separated to EN 61800-5-1 in every control cabinet (SELV / PELV).

External voltage supply of the communication module is necessary if the bus communication is to continue when the supply of the standard device fails.

It is not possible to access the parameters of a standard device disconnected from the mains.

If required, feed the communication module with a separate supply voltage via the 2-pin plug connector.

Assignment of the 2-pin plug connector (X200)

Designation	Explanation
+	V = 24 V DC (20.4 V - 0 % ... 28.8 V + 0 %) I = 130 mA
-	Reference potential for external voltage supply

Terminal data

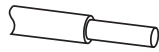
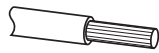
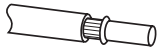
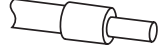
Area	Values
Electrical connection	Plug connector with screw connection
Possible connections	Rigid:
	 0.2 ... 1.5 mm ² (AWG 24 ... 16)
	Flexible:
	 Without wire end ferrule 0.2 ... 1.5 mm ² (AWG 24 ... 16)
	 With wire end ferrule, without plastic sleeve 0.2 ... 1.5 mm ² (AWG 24 ... 16)
 With wire end ferrule, with plastic sleeve 0.2 ... 1.5 mm ² (AWG 24 ... 16)	
Tightening torque	0.5 ... 0.6 Nm (4.4 ... 5.3 lb-in)
Stripping length	6 mm

6 Commissioning

6.1 Before initial switch-on

6 Commissioning

During commissioning, plant-specific data such as motor parameters, operating parameters, responses, and parameters for fieldbus communication are defined for the controller. Lenze devices use codes for this purpose.

The codes of the controller and for communication are saved to the memory module in a non-volatile data set.

In addition, there are codes for diagnosing and monitoring the stations.



Note!

When parameterising the communication module, please observe that the code number depends on the slot of the Servo Drive 9400 in which the communication module has been inserted.

The first two digits of the code number indicate the slot:

- C13nnn for slot MXI1
 - ▶ [Parameters of the communication module for slot MXI1](#) (📖 93)
- C14nnn for slot MXI2
 - ▶ [Parameters of the communication module for slot MXI2](#) (📖 102)

You also have to set the [Communication-relevant parameters of the standard device](#) (📖 91).

6.1 Before initial switch-on



Stop!

Before switching on the controller for the first time, check ...

- the entire wiring for completeness, short circuit and earth fault:
- whether the bus system is terminated through a bus terminating resistor at the first and last physical bus station.
 - ▶ [Activating the bus terminating resistor](#) (📖 25)

6.2 Configuration of the host (master)

The host (master) must be configured before communication with the communication module is possible.

Configuration for the host system (master) and the DP-V0 parameter data channel

For configuring the PROFIBUS you must read the device description file of the communication module into the master.

The device description file for the E94AYCPM communication module (PROFIBUS) can be found in the download area at:

www.Lenze.com

The following language variants of the device description file can be used:

- LENZ07A8.GSD (source file, English)
- LENZ07A8.GSG (German)
- LENZ07A8.GSE (English)

Defining the user data length

The user data length is defined during the initialisation phase of the master.

The Servo Drives 9400 support the configuration of a maximum of 32 process data words (max. 64 bytes). The optional activation of the cyclic parameter data channel additionally occupies 4 process data words (8 bytes). The transfer of PROFIsafe messages, too, occupies 4 additional process data words.

The user data lengths for process input data and process output data are the same.

Description of the device data base file

Selection text	Parameter data with consistency	Process data		Assigned IO memory
		with consistency	without consistency	
DRIVECOM-PAR (cons) + PCD (nW cons)	Yes	n words	-	4 + n words
PCD (nW cons)	-	n words	-	n words
PCD (nW)	-	-	4 words	4 words
Safety (4W)	-	4 words	-	4 words
n = 1 ... 32 process data words				

Example of selecting the device data base file

DRIVECOM-PAR (cons) + PCD (8W cons)

- "Drivecom-PAR (cons)" = DP-V0 parameter data channel (4 words)
- "PCD (8W cons)" = 8 process data words



Tip!

A detailed description of consistency is given in the chapter "[Consistent parameter data](#)" (76).

6.3 Possible DIP switch settings

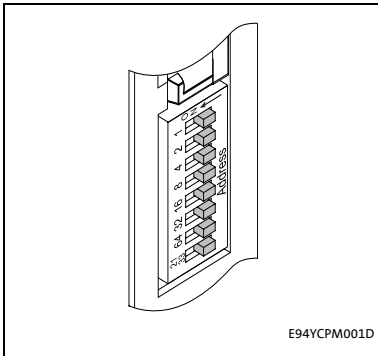

[6-1] DIP switch

The front-panel DIP switches can be used to set:

- The station address (switches 1 ... 64)
- Compatibility with the communication module EMF2133IB (switch 2133)

Lenze setting: all switches in OFF position

6.3.1 Setting the station address

The station addresses must differ from each other if several networked PROFIBUS stations are used. The station address can be set via the DIP switches 1 ... 64 or via the »Engineer« (code [C13899](#) / [C14899](#)).

	Setting the station address via ...	
	DIP switch	C13899 / 14899
Condition	At least one switch 1 ... 64 = ON	<ul style="list-style-type: none"> • Switches 1 ... 64 = OFF • Switch 1 ... 64 = ON (invalid value "127")

The housing labelling indicates the valencies of the individual DIP switches for setting the station address.

DIP switch	64	32	16	8	4	2	1
Switch position	OFF	OFF	ON	OFF	ON	ON	ON
Value	0	0	16	0	4	2	1
Station address	= sum of the valencies = 16 + 4 + 2 + 1 = 23 ▶ DIP switch positions for setting the station address (116)						

- Valid address range: 1 ... 126 (max. 126 slave stations)
- [C13920](#) / [C14920](#): Display of the current address setting of the switches
- [C13864](#) / [C14864](#): Display of the station address active on the PROFIBUS



Note!

Switch off the voltage supply of the communication module and then on again in order to activate changed settings.

Setting the station address via the »Engineer«

In the »Engineer«, the station address can be set via the **Settings** tab.

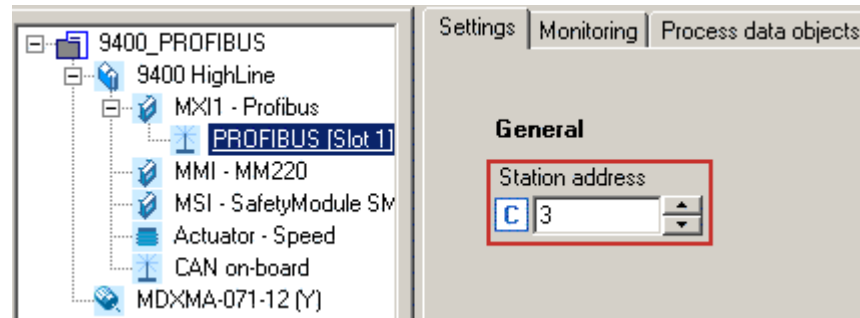

Invalid addresses are displayed in red in the **Station address** input field (code [C13899](#) / [C14899](#)).

Save the changed settings via the device command **C00002 = 11** (save start parameters).

6.3.2 Establishing EMF2133IB compatibility

Establishing EMF2133IB compatibility is necessary if you need to communicate with systems using an EMF2133IB PROFIBUS communication module.

Software compatibility can be set via DIP switch **2133**.

Switch	Switch position	Function
2133	ON	Establishing EMF2133IB compatibility
	OFF	No EMF2133IB compatibility



Note!

- In the compatibility mode "EMF2133IB", only the DRIVECOM parameter data channel (DP-V0) and the Lenze device control can be used.
- Switch off the voltage supply of the communication module and then on again in order to activate changed settings.



Communication manual for the EMF2133IB module

Here you can find information on the configuration of the EMF2133IB communication module and the identification of the module on the bus.

6.4

First switch-on

**Documentation for the standard device**

Observe the safety instructions and residual hazards stated.

**Note!****Establishing communication**

In order to establish communication via an externally supplied communication module, the standard device must be switched on as well.

After communication has been established, the externally supplied module operates independently of the power on/off state of the standard device.

Protection against uncontrolled restart

After a fault (e.g. short-time mains failure), the restart of a drive is not always wanted and - in some cases - even not allowed.

In the Lenze setting of the Servo Drives 9400, the restart protection is activated.

Via **C00142** ("Auto-restart after mains connection"), you can configure the restart behaviour of the controller:

C00142 = "0: Inhibited" (Lenze setting)

- The controller remains inhibited (even if the fault is no longer active).
- The drive starts in a controlled mode by explicitly enabling the controller: LOW-HIGH edge at digital input X5/RFR.

C00142 = "1: Enabled"

- An uncontrolled restart of the drive is possible.

6.5 Going online with »Engineer« via TCI

Via Tool Calling Interfaces (TCI) you can connect to a TCI-capable integrated development environment and parameterise and diagnose your field devices without having to exit the integrated development environment.

You cannot set the TCI communication path directly in the »Engineer«. The selection is carried out by the »STEP7« Siemens software.

The TCI function requires a PN/DP-CPU. Information on the Siemens PLC types that are equipped with the TCI function is provided via the Siemens Support at:

<http://support.automation.siemens.com>



How to configure TCI communication:

1. Allocate names for the individual axes in the »Engineer« project.

In our case, "9400" was allocated for 9400 HighLine, and "8400" for 8400 StateLine:

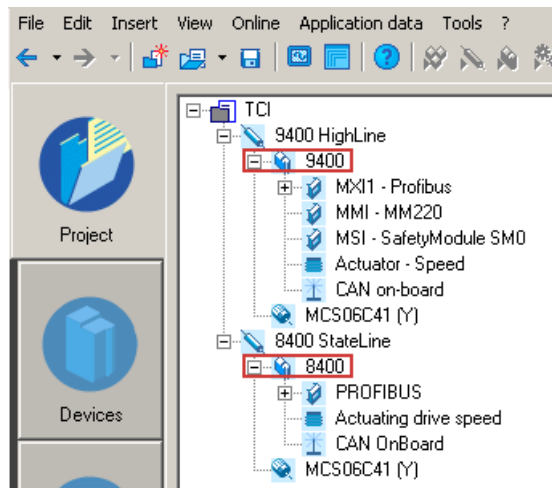

2. In »STEP7« in the »HW Config« ...
 - create the Lenze PROFIBUS stations with the corresponding station addresses and
 - create a PROFIBUS network.

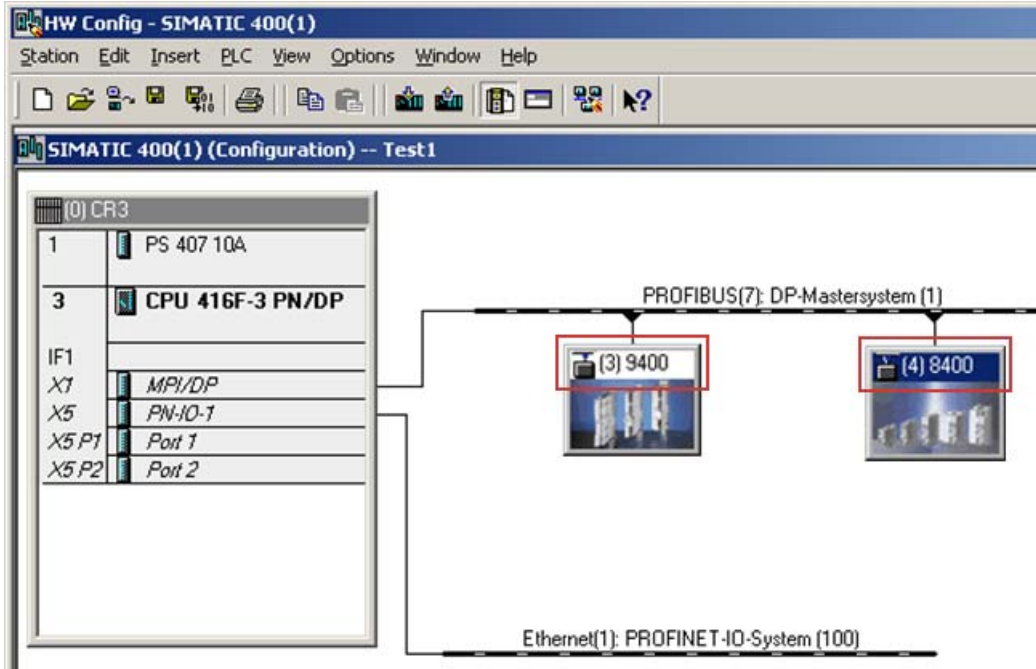

Here a Servo Drive 9400 (address 3) and an Inverter Drive 8400 (address 4) are operated on the PROFIBUS.

- The names of the PROFIBUS slaves in the »HW Config« must be identical to those of the corresponding Lenze axes in the »Engineer« (here "9400" and "8400").
 - The selection of the process data configuration has no impact on TCI communication.
3. Establish an Ethernet connection to the PROFIBUS CPU.

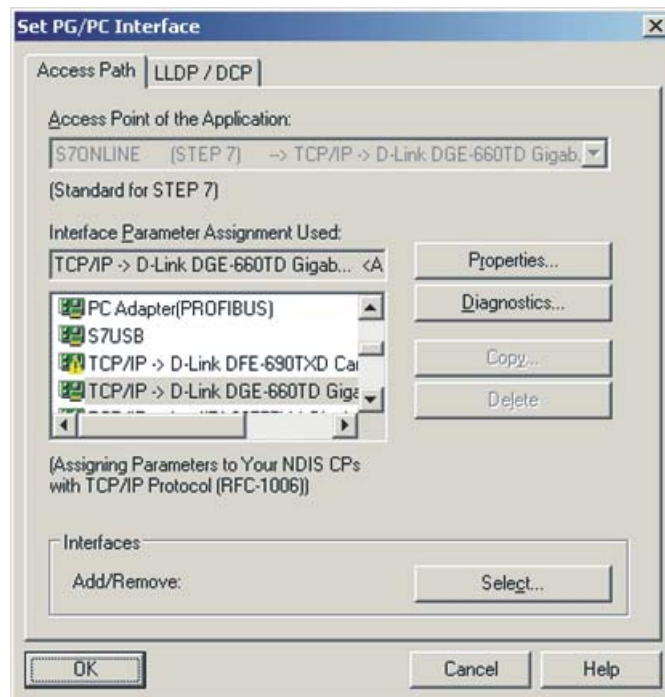

4. Load the »STEP7« project to the CPU.
5. Use the menu command **Insert** → **Station** → **7 PG/PC** to integrate a PG/PC station into the »STEP7« project.

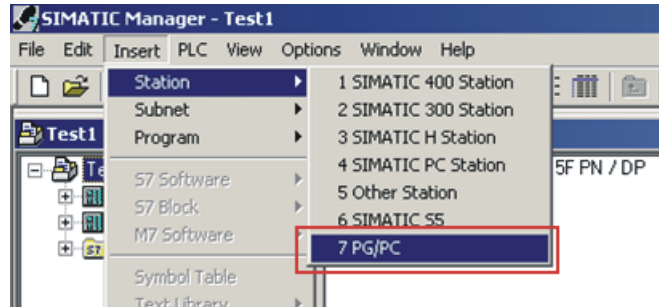

6. By double-clicking the PG/PC station inserted, open its "Properties" dialog.
7. Under the **Interfaces** tab, select a new Ethernet interface and confirm with **OK**.

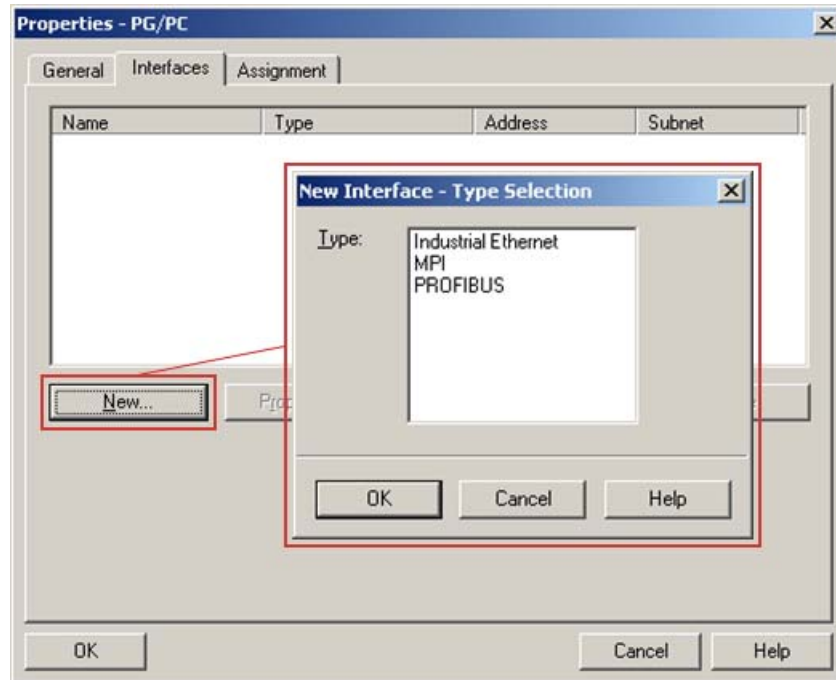

8. Select the connection which you are using to go online with »STEP7« (the same Ethernet connection that has been configured in the »HW Config«).

In our case this is the Ethernet(1) connection:

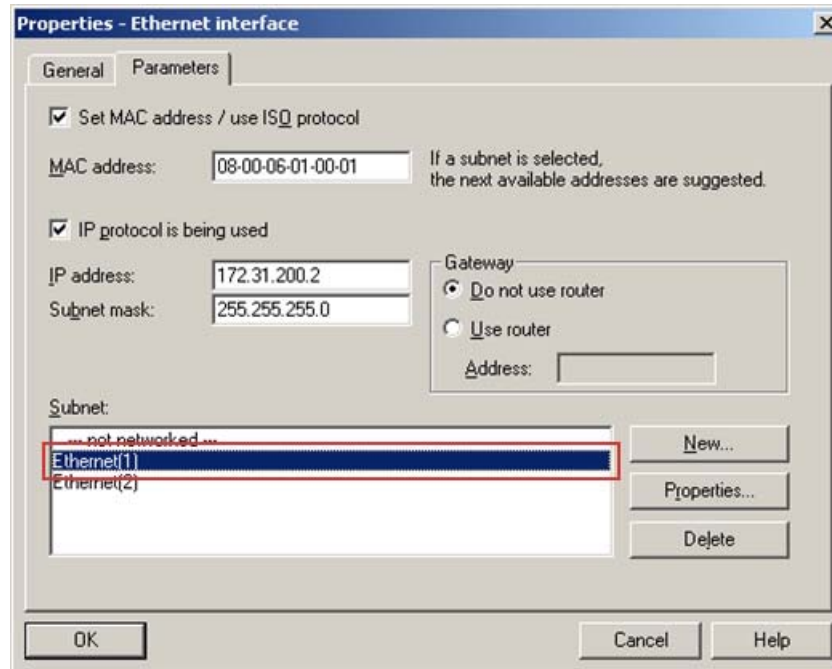

9. Confirm the selection with OK.

The connection has been accepted.

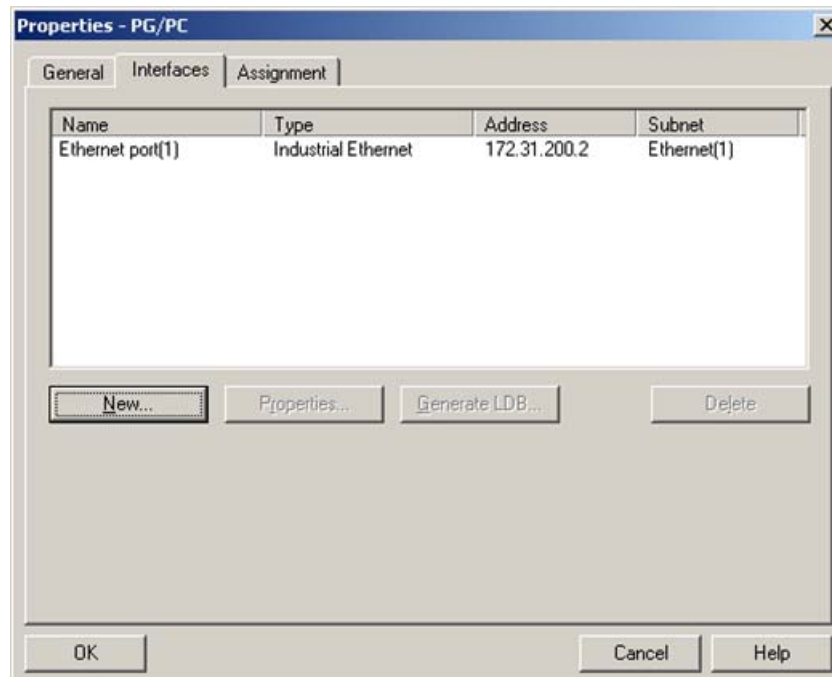

10. Select the actual PG/PC connection under the **Assignment** tab.

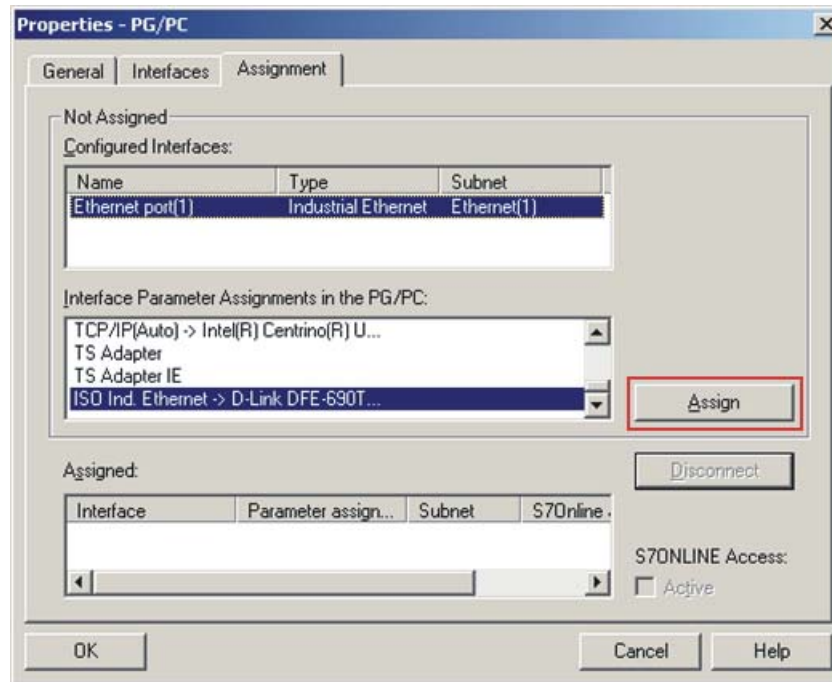

The connection highlighted is assigned by means of the **Assign** button.

11. Confirm the following message with **OK**.

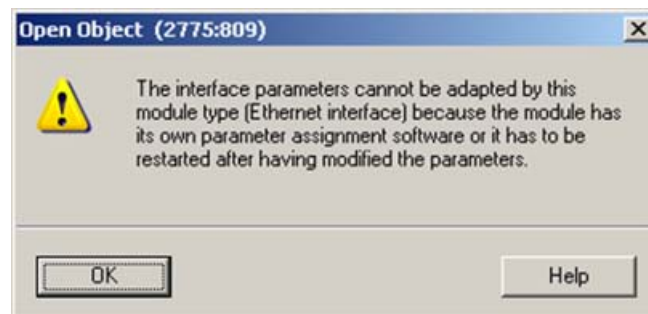

12. After the assignment, the connection appears in the "Assigned" display area. Complete the dialog with OK.

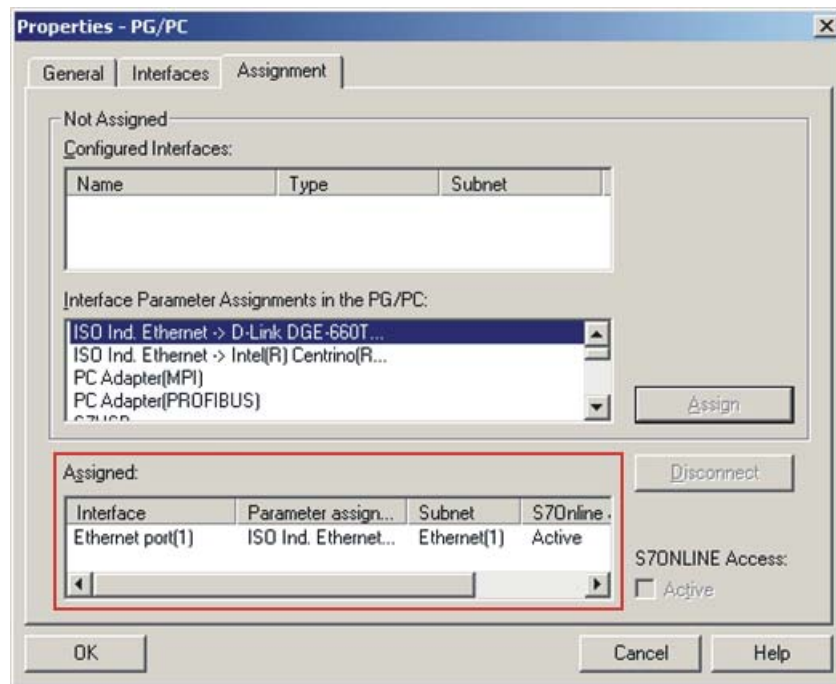

13. In the »STEP7« project, the PG/PC station is marked with a yellow arrow. (The connection selected is active.)

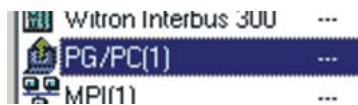

14. Start the transfer of the TCI communication parameters in the »HW Config« using the right mouse button and the menu command **Start device tool** → **L-force Engineer**.

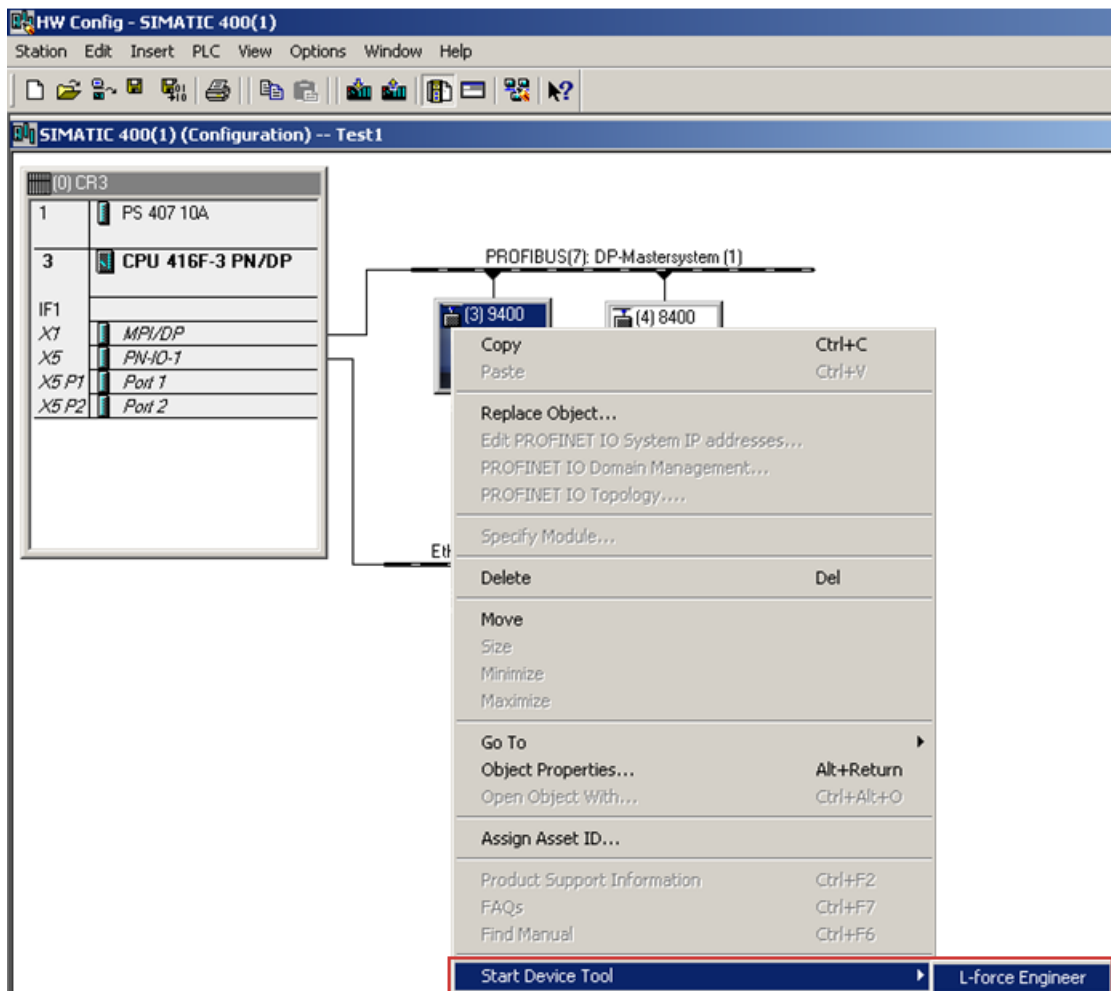

15. If the »Engineer« has already been started with the applicable project, the following message will appear:

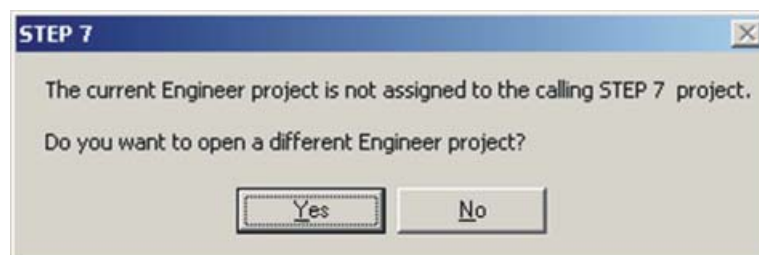

- The message says that the »Engineer« project is not set to a TCI communication path and provides information on whether this action is to be executed now.
- If you confirm the message with **Yes**, the applicable TCI communication parameter settings of the »STEP7« project are transferred to the »Engineer«.

If the »Engineer« has not already been started, it is started automatically now and you have to open the applicable project.

If the project selected has not been set to a TCI communication path yet, this can now be executed with **Yes**:

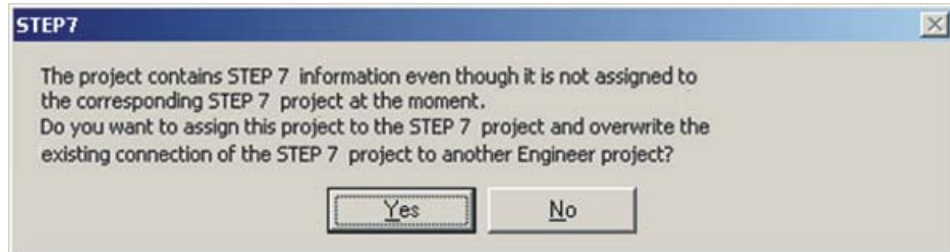

16. The transfer of the TCI communication parameters is documented in the »Engineer« message window.

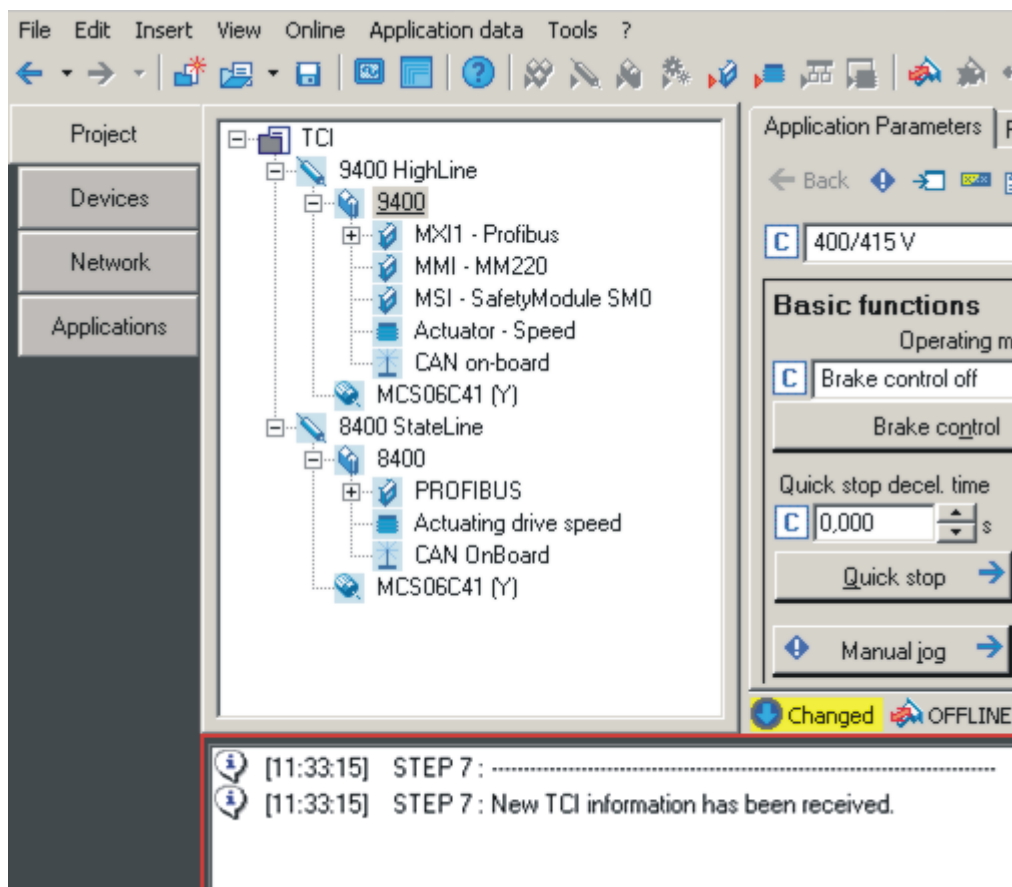

Here the communication settings have been carried out successfully. The individual PROFIBUS addresses in the respective codes have been adapted to the »STEP7« project.

17. If you now call the "Go online" function of the »Engineer«, the TCI communication settings are displayed as follows:

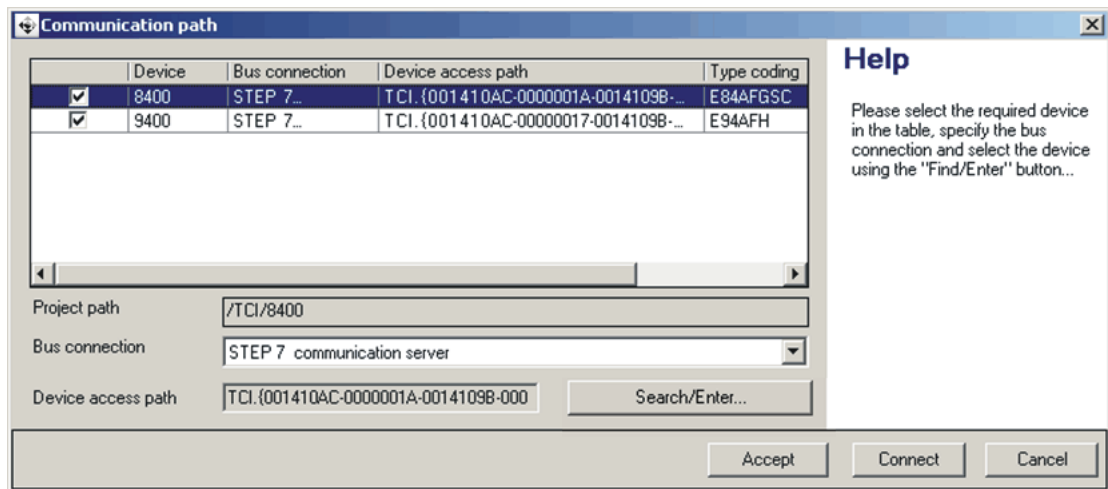

- "STEP7 Communication Server" appears as bus connection.
- The device access path contains a very long string.
- Use the **Connect** button to establish an online connection.
- By means of the **Search/Enter** button, you can update the TCI communication parameters.

7 Data transfer

The PROFIBUS master and controller communicate through the exchange of data telegrams via PROFIBUS. The user data area of the data telegram contains parameter data or process data. In the controller, different communication channels are assigned to the parameter data and process data.

Communication channels

The process data channel serves to transfer process data.

- The process data serve to control the drive controller.
- The host (master) can directly access the process data. In the PLC, for instance, the data are directly saved to the I/O area.
- Process data are not saved in the controller.
- Process data are transferred cyclically between the host system and the controllers (permanent exchange of current input / output data).
- Process data are, for instance, setpoints, actual values, control words and status words.
- The Servo Drives 9400 can exchange a maximum of 32 process data words (16 bits/word) per direction.



Note!

Observe the direction of the information flow!

Process input data (Rx data):

- Process data from the controller (slave) to the master

Process output data (Tx data):

- Process data from the master to the controller (slave)

The parameter data channel serves to transfer parameter data.

- The parameter data channel provides access to all Lenze codes.
- In general, the parameter data transfer is not time-critical.
- Parameter data are, for instance, operating parameters, diagnostic information, and motor data.
- Parameter data changes must be saved via code **C00002** of the Servo Drives 9400.

8 Process data transfer

PDO mapping

The Servo Drives 9400 HighLine enable the individual mapping of process data. For this purpose, the »Engineer« is provided with a port configurator.

Below you can find a description of the steps required to implement a process data communication with a higher-level control, in which a control word/status word and a 32-bit setpoint/actual value are exchanged.



Note!

The »Engineer« screenshots shown on the following pages are only examples for the setting sequence and the resulting screens.



PDO mapping with the »Engineer«

1. You can carry out the mapping of the process data in the »Engineer« on the **Process data objects** tab of the respective fieldbus communication module:

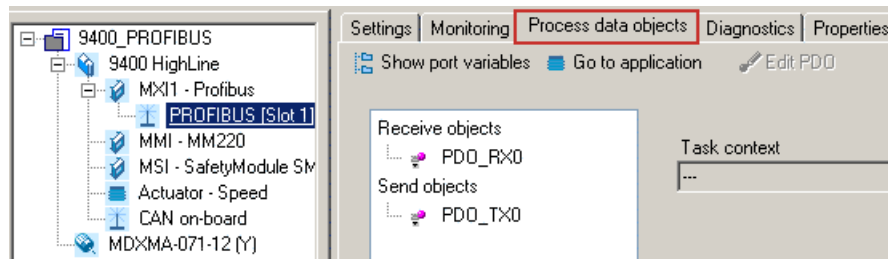

2. Select the receive object **PDO_RX0**:

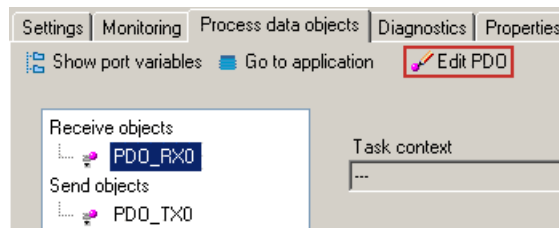

- Click the **Edit PDO** button. The **Process data object structure:PDO_RX0** selection window opens:

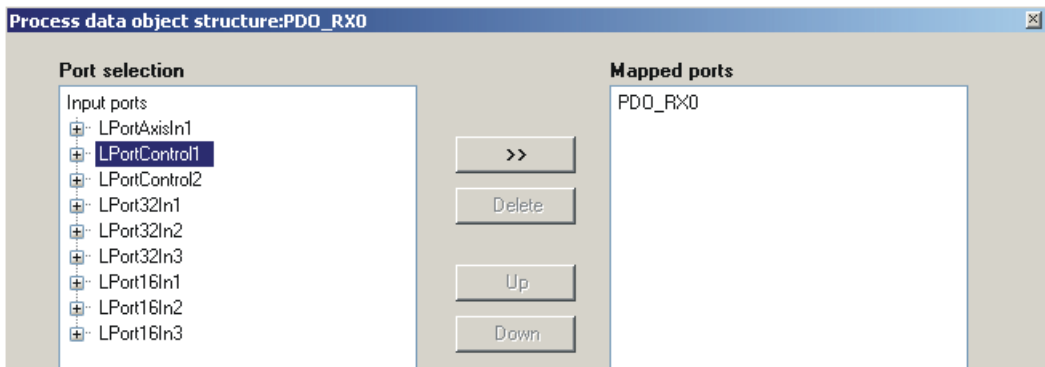

Here you can map the individual ports from the **Port selection** list into the receive PDO "PDO_RX0" by clicking the **>>** button. With the **Up** and **Down** buttons, you can change the order of the ports within the PDO.



Note

The port mapping is not a configuration, which can be carried out online for the Servo Drive 9400 HighLine. For this purpose, the »Engineer« project must be updated and then the application must be downloaded.

In the following example, the ports "LPortControl1" and "Lport32In1" have been mapped into the receive PDO "PDO_RX0" and the ports "LPortStatus1" and "LPort32Out1" have been mapped into the transmit PDO "PDO_TX0":

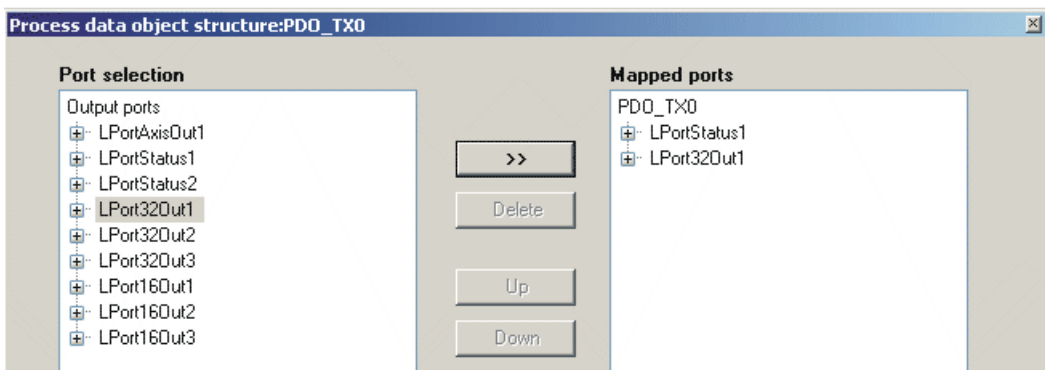
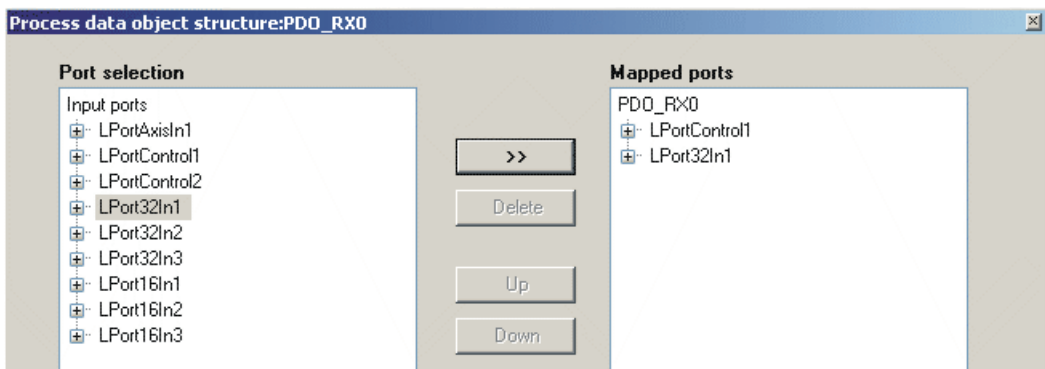

4. Now link the mapped ports to the application signals in the selected technology application.
 - If the »FB Editor« is not activated, you can use the multiplexer codes (from code C03000 onwards) for this purpose.
 - If the »FB Editor« is activated, the multiplexer codes are no longer available. In this case, you have to do the linking directly in the »FB Editor«.

9 Parameter data transfer

9.1 Addressing of the parameter data

9 Parameter data transfer

The E94AYCPM communication module supports the cyclic and acyclic transmission of parameter data:

- Cyclic DP-V0 parameter data are based on the DRIVECOM profile.
If the parameter data channel is active according to DP-V0, it is assigned an additional 4 words of input / output data.
- Acyclic DP-V1 parameter data are based on the PROFIdrive profile.

9.1 Addressing of the parameter data

The parameter data are addressed via codes which can be found in this documentation and in the corresponding documentation of your controller.

▶ [Parameter reference](#) (□ 91)

Addressing of Lenze parameters

In the case of the DP-V0 parameter data channel, the parameters of a device are not addressed directly via Lenze code numbers, but via indices (bytes 3 + 4) and subindices (byte 2).

The conversion is made via an offset (24575 / 0x5FFF):

- PROFIBUS-DP $\text{index}_{\text{dec}} = 24575 - \text{Lenze code number}$
- PROFIBUS-DP $\text{index}_{\text{hex}} = 0x5FFF - \text{Lenze code number}_{\text{hex}}$

Example of C00105 (quick stop deceleration time):

- PROFIBUS-DP $\text{index}_{\text{dec}} = 24575 - 105 = 24470$
- PROFIBUS-DP $\text{index}_{\text{hex}} = 0x5FFF - 0x69 = 0x5F96$

The parameter values are entered into the user data (bytes 5 to 8) of the telegram.

9 Parameter data transfer

9.2 DRIVECOM parameter data channel (DP-V0)

9.2 DRIVECOM parameter data channel (DP-V0)

The DRIVECOM parameter data channel (DP-V0) ...

- enables parameter setting and diagnosing of the controller;
- provides access to all Lenze parameters (codes);
- additionally occupies 4 words (16 bits/word) of the input and output data words in the master;
- is identical for both transmission directions.

9.2.1 Telegram structure (overview)

The telegram of the parameter data channel consists of a total of 8 bytes:

Byte 1	Byte 2	Byte 3	Byte 4	Byte 5	Byte 6	Byte 7	Byte 8
Service	Subindex	Index High byte	Index Low byte	Data 4 / Error 4	Data 3 / Error 3	Data 2 / Error 2	Data 1 / Error 1

The individual bytes are described in detail in the following subchapters.

9.2.2 Byte 1: Service

Byte 1	Byte 2	Byte 3	Byte 4	Byte 5	Byte 6	Byte 7	Byte 8
Service	Subindex	Index High byte	Index Low byte	Data 4 / Error 4	Data 3 / Error 3	Data 2 / Error 2	Data 1 / Error 1

Request and response control for the parameter data channel

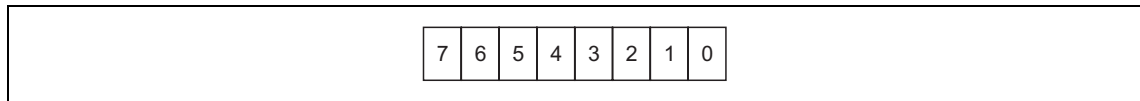

[9-1] Method of reading for bits 0 ... 7

Bit 0 ... 2: Request	
Read/write request from the master to the controller	
000	No request
001	Read request ▶ Reading parameter data from the controller (📖 50)
010	Write request (write data to the controller) ▶ Writing parameter data to the controller (📖 50)
100	Data transfer abort by the master ▶ Data transfer abort by the master (📖 51)

Bit 3
Reserved

Bit 4/5: Data length	
Data length ≤ 4 bytes in the telegram bytes 5 ... 8 (data 1 ... 4 / error 1 ... 4)	
00	1 byte
01	2 bytes
10	3 bytes
11	4 bytes

Bit 6: Handshake	
Indicates a new request.	
<ul style="list-style-type: none"> • The state of this (toggle) bit is changed by the master for every new request. • The controller copies the bit into its response telegram. 	

Bit 7: Status	
Status information from the controller to the master when sending the request confirmation. This status bit informs the master whether the request has been carried out without errors.	
0	Request completed without errors. Bytes 5 ... 8 contain a parameter value (Data 1 ... 4).
1	Request not completed because of an error. <ul style="list-style-type: none"> • The set status bit indicates that the telegram is an "error telegram". • Bytes 5 ... 8 contain an error code (Error 1 ... 4). ▶ Error codes (📖 54)

9 Parameter data transfer

9.2 DRIVECOM parameter data channel (DP-V0)

9.2.2.1 Reading parameter data from the controller

General procedure:

1. Define the user data area of the controller, i.e. define the location of the DP user data in the host (observe manufacturer-specific information).
2. Enter the address of the required parameter in the "Index" and "Subindex" fields (DP output data).
3. Request in the service byte = read request.
The handshake bit in the service byte must be changed (DP output data).
4. Check whether the handshake bit in the service byte is the same for the DP input data and the DP output data.
 - If the handshake bit is the same, the response has been received.
 - It is useful to implement a time monitoring tool.
5. Check whether the status bit in the service byte is set:
 - Status bit is not set: The "Data/Error" field contains the required [Parameter value \(data\)](#) (□ 53).
 - Status bit is set: The read request has not been executed correctly. The "Data/Error" field contains the [Error codes](#) (□ 54).

9.2.2.2 Writing parameter data to the controller

General procedure:

1. Define the user data area of the controller, i.e. define the location of the DP user data in the host (observe manufacturer-specific information).
2. Enter the address of the required parameter in the "Index" and "Subindex" fields (DP output data).
3. Enter the parameter value in the "Data/Error" field.
4. Request in the service byte = write request.
The handshake bit in the service byte must be changed (DP output data).
5. Check whether the handshake bit in the service byte is the same for the DP input data and the DP output data.
 - If the handshake bit is the same, the response has been received.
 - It is useful to implement a time monitoring tool.
6. Check whether the status bit in the service byte is set:
 - Status bit is not set: The write request has been executed correctly.
 - Status bit is set: The write request has not been executed correctly. The "Data/Error" field contains the [Error codes](#) (□ 54).

9.2.2.3 Abort of data transfer by the controller

The error telegram is used to abort the transfer.

- The error telegram is marked by a set status bit in the service byte.
- The telegram can either be the response to an "Initiate Read/Write Service" or to a "Read/Write Segment Service".

Controller response in the event of an error:

Byte 1	Byte 2	Byte 3	Byte 4	Byte 5	Byte 6	Byte 7	Byte 8
Service	Subindex	Index High byte	Index Low byte	Data 4 / Error 4	Data 3 / Error 3	Data 2 / Error 2	Data 1 / Error 1
1t110000	SIDX	IDXH	IDXL	Error Class	Error code	Additional Code High	Additional Code Low

9.2.2.4 Data transfer abort by the master

The master can use this error telegram to abort a running segment transmission.

- The error telegram is marked by a set status bit in the service byte.
- The service byte also contains the request code "4" (100_{bin}).
- Bit 4 and bit 5 in the service byte (data length) are without meaning.
- Additional information (subindex, index, error information) is not transmitted.

Byte 1	Byte 2	Byte 3	Byte 4	Byte 5	Byte 6	Byte 7	Byte 8
Service	Reserved	Reserved	Reserved	Reserved	Reserved	Reserved	Reserved
1txx0100	0	0	0	0	0	0	0

Controller response in the case of correct execution:

The controller confirms the error telegram of the master by also sending an error telegram.

- The error telegram is marked by a set status bit in the service byte.
- In the case of correct execution, the telegram contains the error information "0x00000000" in bytes 5 ... 8.
- Additional information (subindex, index) is not transmitted.

Byte 1	Byte 2	Byte 3	Byte 4	Byte 5	Byte 6	Byte 7	Byte 8
Service	SIDX	IDXH	IDXL	Error Class	Error code	Additional Code High	Additional Code Low
1t110000	0	0	0	0	0	0	0

9.2.3 Byte 2: Subindex

Byte 1	Byte 2	Byte 3	Byte 4	Byte 5	Byte 6	Byte 7	Byte 8
Service	Subindex	Index High byte	Index Low byte	Data 4 / Error 4	Data 3 / Error 3	Data 2 / Error 2	Data 1 / Error 1

Additional addressing via the subindex is required for those codes of the Servo Drives 9400 that contain a subcode (see code table).

9.2.4 Bytes 3 + 4: Index

Byte 1	Byte 2	Byte 3	Byte 4	Byte 5	Byte 6	Byte 7	Byte 8
Service	Subindex	Index High byte	Index Low byte	Data 4 / Error 4	Data 3 / Error 3	Data 2 / Error 2	Data 1 / Error 1

The parameter (Lenze code) is selected via these two bytes according to the formula:

$$\text{Index} = 24575 - \text{Lenze code number}$$

(See also "[Addressing of Lenze parameters](#)" (47))

Example:

The parameter C00105 (quick stop (QSP) deceleration time) is to be addressed:

- Index = $24575 - 105 = 24470 = 0x5F96$
- The entries in bytes 3 + 4 for this example would be:

Byte 1	Byte 2	Byte 3	Byte 4	Byte 5	Byte 6	Byte 7	Byte 8
Service	Subindex	0x5F	0x96	Data 4 / Error 4	Data 3 / Error 3	Data 2 / Error 2	Data 1 / Error 1

9.2.5 Bytes 5 ... 8: Parameter value / error information

Byte 1	Byte 2	Byte 3	Byte 4	Byte 5	Byte 6	Byte 7	Byte 8
Service	Subindex	Index High byte	Index Low byte	Data 4 / Error 4	Data 3 / Error 3	Data 2 / Error 2	Data 1 / Error 1

The state of status bit 7 in the service byte determines the meaning of this data field:

Status bit	Meaning of bytes 5 ... 8
0	Bytes 5 ... 8 contain a parameter value (Data 1 ... 4).
1	Bytes 5 ... 8 contain an error code (Error 1 ... 4). ▶ Error codes (📖 54)

Parameter value (data)



Note!

Strings or data blocks cannot be transmitted.

Depending on the data format, the length of the parameter value is between 1 and 4 bytes.

Data are saved in the Motorola format, i.e. first the high byte (high word), then the low byte (low word):

Byte 5	Byte 6	Byte 7	Byte 8
High byte	Low byte	High byte	Low byte
High word		Low word	
Double word			

Principle for the assignment of bytes 5 ... 8 with parameter values of different lengths:

Byte 5	Byte 6	Byte 7	Byte 8
Parameter value (length 1)	0x00	0x00	0x00
Parameter value (length 2)		0x00	0x00
Parameter value (length 4)			

9.2.6 Error codes

The following error messages may appear:

Byte 8	Byte 7	Byte 6	Byte 5	Meaning
Error 1	Error 2	Error 3	Error 4	
0x06	0x03	0x00	0x00	No right to access
0x06	0x05		0x11	Invalid subindex
0x06	0x05		0x12	Data length too large
0x06	0x05		0x13	Data length too small
0x06	0x07		0x00	Object does not exist
0x06	0x08		0x00	Data types do not comply with each other
0x08	0x00		0x00	Request cannot be executed
0x08	0x00		0x20	Request cannot be executed at the moment
0x08	0x00		0x22	Request cannot be executed due to the device status / The parameter can only be changed in the case of a controller inhibit
0x08	0x00		0x30	Value ranged exited
0x08	0x00		0x31	Parameter value too high
0x08	0x00		0x32	Parameter value too low
0x08	0x00		0x80	Hardware error

9.2.7 Telegram examples

9.2.7.1 Read request: Querying the heatsink temperature

The heatsink temperature of the controller is to be read.

- Code to be read: C00061
- Heatsink temperature: 43 °C

Byte 1: Service (request)

Request = $0t110001_{bin}$

- Bit 0 ... 2 = 001_{bin} for read request
- Bit 3 = 0 (reserved)
- Bit 4/5 = 01_{bin} for 2-byte data length (only relevant for the response telegram)
- Bit 6 = handshake bit (t ≡ status is changed in the response telegram)
- Bit 7 = status bit (only relevant for the response telegram)

Byte 2: Subindex

Subindex = 0 because code C00061 does not contain any subindices.

Bytes 3 + 4: Index

Index = 24575 - code number = 24575 - 61 = 24514 = $0x5FC2$

- Byte 3 (high byte) = $0x5F$
- Byte 4 (low byte) = $0xC2$

Bytes 5 ... 8: Data

The response telegram contains the value of code C00061:

Data 3 + 4 = 43 [°C] x 1 (internal factor) = 43 = $0x002B$

Result

Request telegram from master to drive:

Byte 1	Byte 2	Byte 3	Byte 4	Byte 5	Byte 6	Byte 7	Byte 8
Service	Subindex	Index High byte	Index Low byte	Data 4	Data 3	Data 2	Data 1
0x01	0x00	0x5F	0xC2	0x00	0x00	0x00	0x00
$0t000001_{bin}$	00000000_{bin}	01011111_{bin}	11000010_{bin}	00000000_{bin}	00000000_{bin}	00000000_{bin}	00000000_{bin}
Waiting for change of handshake bit 6 in service byte 1 of the response.							

Response telegram from drive to master (for correct execution):

Byte 1	Byte 2	Byte 3	Byte 4	Byte 5	Byte 6	Byte 7	Byte 8
Service	Subindex	Index High byte	Index Low byte	Data 4	Data 3	Data 2	Data 1
0x11	0x00	0x5F	0xC2	0x00	0x2B	0x00	0x00
$0t010001_{bin}$	00000000_{bin}	01011111_{bin}	11000010_{bin}	00000000_{bin}	00101011_{bin}	00000000_{bin}	00000000_{bin}

9.2.7.2 Write request: Setting the deceleration time for quick stop (QSP)

In the controller, the deceleration time for quick stop (QSP) is to be set to 50 ms.

- Code to be written: C00105

Byte 1: Service (request)

Request = $0t110010_{bin}$

- Bit 0 ... 2 = 010_{bin} for write request
- Bit 3 = 0 (reserved)
- Bit 4/5 = 11_{bin} for 4-byte data length
- Bit 6 = handshake bit (t ≡ status is changed in the response telegram)
- Bit 7 = status bit (only relevant for the response telegram)

Byte 2: Subindex

Subindex = 0 because code C00105 does not contain any subindices.

Bytes 3 + 4: Index

Index = 24575 - code number = 24575 - 105 = 24470 = $0x5F96$

- Byte 3 (high byte) = $0x5F$
- Byte 4 (low byte) = $0x96$

Bytes 5 ... 8: Data

The parameter value of 0.05 s to be set is multiplied by the code-specific factor of "1000" and entered in the user data:

Data 1 ... 4 = $0.05 [s] \times 1000$ (internal factor) = 50 = $0x00000032$

Result:

Request telegram from master to drive:

Byte 1	Byte 2	Byte 3	Byte 4	Byte 5	Byte 6	Byte 7	Byte 8
Service	Subindex	Index High byte	Index Low byte	Data 4	Data 3	Data 2	Data 1
0x72	0x00	0x5F	0x96	0x00	0x00	0x00	0x32
$0t110010_{bin}$	00000000_{bin}	01011111_{bin}	10010110_{bin}	00000000_{bin}	00000000_{bin}	00000000_{bin}	00110010_{bin}
Waiting for change of handshake bit 6 in service byte 1 of the response							

Response telegram from drive to master (for correct execution):

Byte 1	Byte 2	Byte 3	Byte 4	Byte 5	Byte 6	Byte 7	Byte 8
Service	Subindex	Index High byte	Index Low byte	Data 4	Data 3	Data 2	Data 1
0x40	0x00	0x5F	0x96	0x00	0x00	0x00	0x32
$0t000000_{bin}$	00000000_{bin}	01011111_{bin}	10010110_{bin}	00000000_{bin}	00000000_{bin}	00000000_{bin}	00110010_{bin}

9 Parameter data transfer

9.3 PROFIdrive parameter data channel (DP-V1)

9.3 PROFIdrive parameter data channel (DP-V1)

Data communication with PROFIBUS-DP-V0 is characterised by cyclic diagnostics and cyclic process data and parameter data transfer.

An optional service expansion is the acyclic parameter data transfer of PROFIBUS-DP-V1. This service does not impair the functionality of the standard services under PROFIBUS-DP-V0.

PROFIBUS-DP-V0 and PROFIBUS-DP-V1 can be operated simultaneously in the same network. This enables the step-by-step expansion or retrofitting of a system.

The services of PROFIBUS-DP-V1 can be used by the class 1 master (PLC) and the class 2 master (diagnostics master, etc.).

The integration of the acyclic service into the fixed bus cycle depends on the corresponding configuration of the class 1 master:

- With configuration, a time slot is reserved.
- Without configuration the acyclic service is appended when a class 2 master acyclically accesses a DP-V1 slave.

Features

- Parameter number and subindex addresses with a width of 16 bits each.
- Several parameter requests can be combined to one request (multi-parameter request).
- There is always only one parameter request in process (no pipelining).
- A parameter request/response must fit into a data block (max. 240 bytes). Requests/responses cannot be split into several data blocks.
- No spontaneous messages are transferred.
- There are only acyclic parameter requests.
- Profile-specific parameters can be read independently of the slave state.

9.3.1 Connection establishment between master and slave

A class 1 master can always request parameters from a slave if the slave is in the "Data_Exchange" state.

In addition to the class 1 master, a class 2 master can establish a communication connection to the slave:

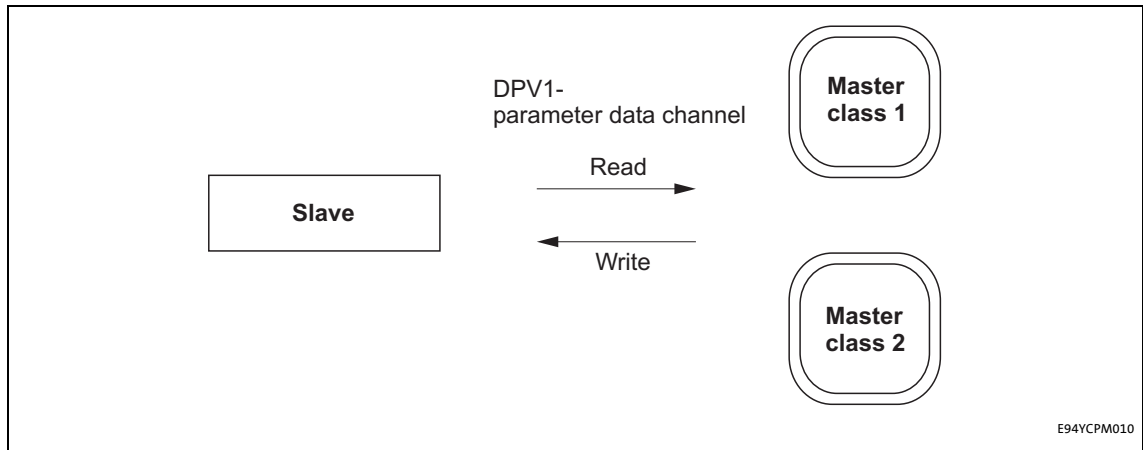

[9-2] Data communication via the DP-V1 parameter data channel

9.3.2 Acyclic data transfer

**Note!**

A parameter request refers to one or several parameter(s) (multi-parameter request).

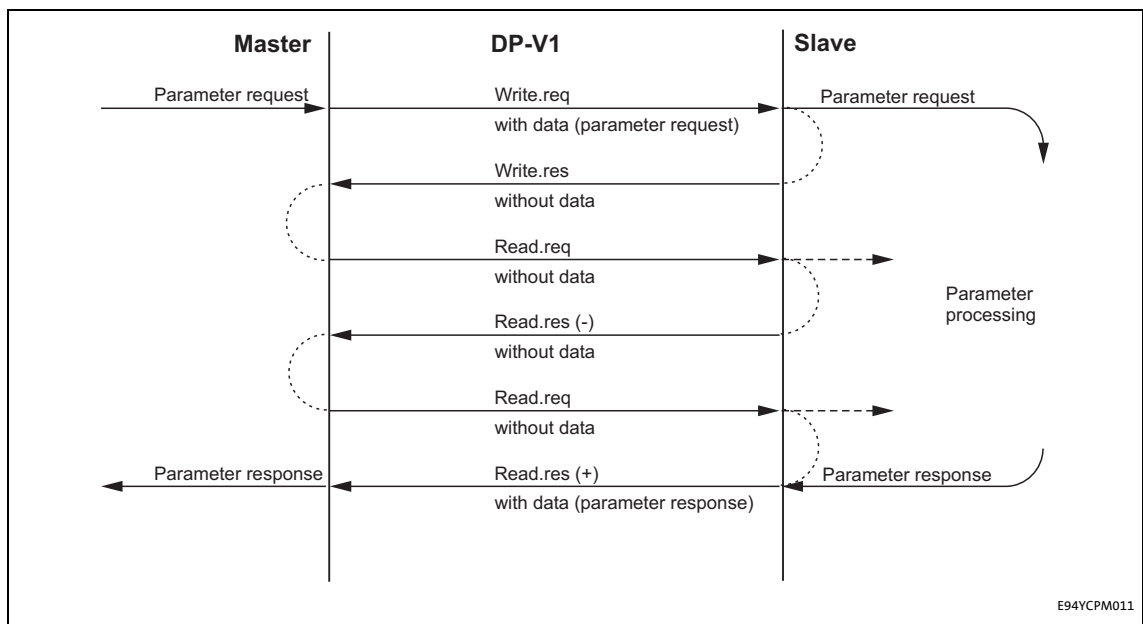

[9-3] Transmission directions

Explanation

- A "Write.req" is used to pass the data set (DB47) to the slave in the form of a parameter request.
- With "Write.res" the master receives the confirmation for the receipt of the message.
- The master requests the response of the slave with "Read.req".
- The slave responds with "Read.res (-)" if processing has not yet been completed.
- After parameter processing, the parameter request is completed by transmitting the parameter response to the master with "Read.res (+)".

9.3.3 Telegram structure

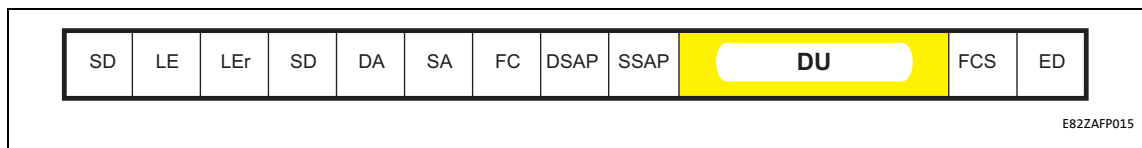

[9-4] PROFIBUS data telegram

The data unit (DU) contains the DP-V1 header and the parameter request or the parameter response.

The following subchapters describe the parameter request and the parameter response in detail.



Note!

The DP-V1 header consists of:

- Function identification
- Slot number
- Data set
- Length of the user data

Please refer to the corresponding PROFIBUS specification for further information on the DP-V1 header.

Assignment of the user data depending on the data type

Depending on the data type used, the user data are assigned as follows:

Data type	Length	User data assignment				
		Byte 1	Byte 2	Byte 3	Byte 4	Byte ...
String	x bytes					
U8	1 byte		0x00			
U16	2 bytes	High byte	Low byte			
U32	4 bytes	High word		Low word		
		High byte	Low byte	High byte	Low byte	

9.3.3.1 Reading parameter data from the controller



Note!

- When a read request is processed, no parameter value is written to the slave.
- In the case of a multi-parameter read request, the parameter attribute, index, and subindex are repeated with the number "n" of the requested parameters.
- A read request must not exceed the maximum data length of 240 bytes.

Request header

Byte 1	Byte 2	Byte 3	Byte 4
Request reference	Request identification	Axis	Number of indices

Field	Data type	Values
Request reference	U8	This value is specified by the master
Request identification	U8	0x01: Request parameters for reading
Axis	U8	0x00 or 0x01
Number of indices	U8	0x"n" (n = number of parameters requested)

Parameter attribute

Byte 5	Byte 6
Attribute	Number of subindices

Field	Data type	Values
Attribute	U8	0x10: Value
Number of subindices	U8	0x00 (For array elements: Enter the number of array elements required.)

Index and subindex

Byte 7	Byte 8	Byte 9	Byte 10
Index		Subindex	
High byte	Low byte	High byte	Low byte

Field	Data type	Values
Index	U16	0x0001 ... 0xFFFF (1 ... 65535)
Subindex	U16	0x0001 ... 0xFFFF (1 ... 65535)

9.3.3.2 Response to a correctly executed read request



Note!

Responses to a read request do not contain parameter attributes, indices and subindices.

Response header

Byte 1	Byte 2	Byte 3	Byte 4
Request reference (mirrored)	Response identification	Axis (mirrored)	Number of indices

Field	Data type	Values
Request reference	U8	Mirrored value of the parameter request
Response identification	U8	0x01: Parameter has been read
Axis	U8	0x00 or 0x01
Number of indices	U8	0x"n" (n = number of parameters requested)

Parameter format

Byte 5	Byte 6
Format	Number of values

Field	Data type	Values
Format	U8	0x02: Integer8 0x03: Integer16 0x04: Integer32 0x05: Unsigned8 0x06: Unsigned16 0x07: Unsigned32 0x09: Visible string 0x0A: Octet string 0x40: Zero 0x41: Byte 0x42: Word 0x43: Double word
Number of values	U8	0x01 or number of requested subindices/parameters (with several subindices/parameters only the parameter value is repeated). In the case of string codes, the number of characters is entered here.

Parameter value

Byte 7	Byte 8	Byte 9	Byte 10
Value			

Field	Data type	Values
Value	String	Any (length > 4 bytes possible)
	U8	0x00 0xFF
	U16	0x0000 0xFFFF
	U32	0x0000 0000 0xFFFF FFFF

9.3.3.3 Response to a read error



Note!

In case of a multi-parameter request, correct and possibly faulty messages are summarised in one telegram.

Correct message

- Format: data type of the value requested
- Number of values: as described in chapter "[Reading parameter data from the controller](#)" (61).
- Parameter value: value requested

Faulty message

- Format: 0x44
- Number of values: 0x01 or 0x02
- Error code without additional information (for number of values = 0x01) or
- Error code with additional information (for number of values = 0x02)

A faulty access to a parameter "n" is indicated at the nth position in the response telegram of a multi-parameter request.

Response header

Byte 1	Byte 2	Byte 3	Byte 4
Request reference (mirrored)	Response identification	Axis (mirrored)	Number of indices

Field	Data type	Values
Request reference	U8	Mirrored value of the parameter request
Response identification	U8	0x81: Parameter has not been read The data in the bytes 7 + 8 must be interpreted as an error code.
Axis	U8	0x00 or 0x01
Number of indices	U8	0x"n" (n = number of parameters requested)

Parameter format

Byte 5	Byte 6
Format	Number of values

Field	Data type	Values
Format	U8	0x44: Error
Number of values	U8	0x01: Error code without additional information 0x02: Error code with additional information

Error code

Byte 7	Byte 8	Byte 9	Byte 10
Error code		Additional information (if available)	
High byte	Low byte	High byte	Low byte

Field	Data type	Values
Error code	U16	0x0000 0xFFFF
Additional information (if available)	U16	▶ Error codes (🔗 70)

9.3.3.4 Writing parameter data to the controller



Note!

When a multi-parameter write request is transferred, the ...

- Parameter attribute
- Index and subindex

and then the ...

- Parameter format
- Parameter value

... are repeated with the number "n" of the parameters addressed.

A write request must not exceed the maximum data length of 240 bytes.

Request header

Byte 1	Byte 2	Byte 3	Byte 4
Request reference	Request identification	Axis	Number of indices

Field	Data type	Values
Request reference	U8	This value is defined by the master.
Request identification	U8	0x02: Write parameter
Axis	U8	0x00 or 0x01
Number of indices	U8	0x"n" (n = number of parameters addressed)

Parameter attribute

Byte 5	Byte 6
Attribute	Number of subindices

Field	Data type	Values
Attribute	U8	0x10: Value
Number of subindices	U8	0x00 (For array elements: Enter the number of array elements required.)

Index and subindex

Byte 7	Byte 8	Byte 9	Byte 10
Index		Subindex	
High byte	Low byte	High byte	Low byte

Field	Data type	Values
Index	U16	0x0001 ... 0xFFFF (1 ... 65535)
Subindex	U16	0x0001 ... 0xFFFF (1 ... 65535)

Parameter format

Byte 11	Byte 12
Format	Number of values

Field	Data type	Values
Format	U8	0x02: Integer8 0x03: Integer16 0x04: Integer32 0x05: Unsigned8 0x06: Unsigned16 0x07: Unsigned32 0x09: Visible string 0x0A: Octet string 0x40: Zero 0x41: Byte 0x42: Word 0x43: Double word
Number of values	U8	0x01 or number of written subindices/parameters (with several subindices/parameters only the parameter value is repeated). In the case of string codes, the number of characters is entered here.

Parameter value

Byte 13	Byte 14	Byte 15	Byte 16
Value			

Field	Data type	Values
Value	String	Any (length > 4 bytes possible)
	U8	0x00 0xFF
	U16	0x0000 0xFFFF
	U32	0x0000 0000 0xFFFF FFFF

9.3.3.5 Response to a correctly executed write request



Note!

In the case of a multi-parameter request, correct and possible faulty messages are summarised in one telegram. They have the following data contents:

Correct message

- Format: 0x40
- Number of values: 0x00

Faulty message

- Format: 0x44
- Number of values: 0x01 or 0x02
- Error code without additional information (for number of values = 0x01) or with additional information (for number of values = 0x02)

A faulty access to a parameter "n" is indicated at the nth position in the response telegram of a multi-parameter request.

Response header

Byte 1	Byte 2	Byte 3	Byte 4
Request reference (mirrored)	Response identification	Axis (mirrored)	Number of indices

Field	Data type	Values
Request reference	U8	Mirrored value of the parameter request
Response identification	U8	0x02: Parameter has been written
Axis	U8	0x00 or 0x01
Number of indices	U8	0xn (n = number of parameter addressed)

9.3.3.6 Response to a write error

Response header

Byte 1	Byte 2	Byte 3	Byte 4
Request reference (mirrored)	Response identification	Axis (mirrored)	Number of indices

Field	Data type	Values
Request reference	U8	Mirrored value of the parameter request
Response identification	U8	0x82: Parameter has not been written The data in the bytes 7 + 8 must be interpreted as an error code.
Axis	U8	0x00 or 0x01
Number of indices	U8	0x"n" (n = number of parameters addressed)

Parameter format

Byte 5	Byte 6
Format	Number of values

Field	Data type	Values
Format	U8	0x44: Error
Number of values	U8	0x01: Error code without additional information 0x02: Error code with additional information

Error code

Byte 7	Byte 8	Byte 9	Byte 10
Error code		Additional information (if available)	
High byte	Low byte	High byte	Low byte

Field	Data type	Values
Error code	U16	0x0000 0xFFFF
Additional information (if available)	U16	▶ Error codes (□ 70)

9.3.4 Error codes

Error code	Description	Explanation	Additional information
0x0000	Impermissible parameter number	Access to unavailable parameter	-
0x0001	Parameter value cannot be changed	Change access to a parameter value that cannot be changed	Subindex
0x0002	Lower or upper value limit exceeded	Change access with value beyond the value limits	Subindex
0x0003	Faulty subindex	Access to unavailable subindex	Subindex
0x0004	No array	Access with subindex to non-indicated parameter	-
0x0005	Wrong data type	Change access with value that does not match the data type of the parameter	-
0x0006	No setting permitted (only resettable)	Change access with value unequal to 0 where this is not permitted	Subindex
0x0007	Description element cannot be changed	Change access to a description element that cannot be changed	Subindex
0x0008	Reserved	(PROFIdrive profile V2: PPO-Write requested in the IR is not available)	-
0x0009	Description data not available	Access to unavailable description (parameter value is available)	-
0x000A	Reserved	(PROFIdrive profile V2: Wrong access group)	-
0x000B	No parameter change rights	Change access without parameter change rights	-
0x000C	Reserved	(PROFIdrive profile V2: Wrong password)	-
0x000D	Reserved	(PROFIdrive profile V2: Text in the cyclic traffic cannot be read)	-
0x000E	Reserved	(PROFIdrive profile V2: Name in the cyclic traffic cannot be read)	-
0x000F	No text array available	Access to unavailable text array (parameter value is available)	-
0x0010	Reserved	(PROFIdrive profile V2: Missing PPO-Write)	-
0x0011	Request cannot be executed due to the operating state	Access is not possible due to temporary reasons not specified here	-
0x0012	Reserved	(PROFIdrive profile V2: Other error)	-
0x0013	Reserved	(PROFIdrive profile V2: date in the cyclic traffic cannot be read)	-
0x0014	Value impermissible	Change access with the value that is inside the value limits but not permissible for other permanent reasons (parameters with defined individual values)	Subindex
0x0015	Response too long	The length of the current response exceeds the maximum transmittable length	-
0x0016	Parameter address impermissible	Impermissible or non-supported value for attribute, number of subindices, parameter number, or subindex, or a combination	-
0x0017	Format impermissible	Write request: Impermissible or non-supported format of parameter data	-
0x0018	Number of values not consistent	Write request: Number of values of the parameter data do not match the number of subindices in the parameter address	-
0x0019	Reserved	-	-
...			
0x0064			

9

Parameter data transfer

9.3

PROFIdrive parameter data channel (DP-V1)

Error code	Description	Explanation	Additional information
0x0065	Manufacturer-specific	-	-
...			
0x00FF			

9.3.5 Telegram examples

9.3.5.1 Read request: Querying the heatsink temperature

The heatsink temperature of the controller is to be read.

- Code to be read: C00061
- Heatsink temperature: 43 °C

Parameter request

Byte 1	Byte 2	Byte 3	Byte 4
Request reference	Request identification	Axis	Number of indices
0xXX	0x01	0x00	0x01
	Request parameters for reading		

Byte 5	Byte 6
Attribute	Number of subindices
0x10	0x00
Value	No subindex

Byte 7	Byte 8	Byte 9	Byte 10
Index		Subindex	
High byte	Low byte	High byte	Low byte
0x5F	0xC2	0x00	0x00
Index = 24575 - code no. = 24575 - 61 = 24514 = 0x5F C2		No subindex	

Parameter response to a correctly executed read request

Byte 1	Byte 2	Byte 3	Byte 4
Request reference (mirrored)	Response identification	Axis (mirrored)	Number of indices
0xXX	0x01	0x00	0x01
	Parameter has been read		

Byte 5	Byte 6
Format	Number of values
0x03	0x01
Integer16	1 value

Byte 7	Byte 8
Value	
High byte	Low byte
0x00	0x2B
Value read = 0x 00 2B = 43 x 1 (internal factor) = 43 [°C]	

Parameter response to a read error

Byte 1	Byte 2	Byte 3	Byte 4
Request reference (mirrored)	Response identification	Axis (mirrored)	Number of indices
0xXX	0x81	0x00	0x01
	Parameter has not been read		

Byte 5	Byte 6
Format	Number of values
0x44	0x01
Error	Error code without additional information

Byte 7	Byte 8
Error code	
High byte	Low byte
For the meaning, see the " Error codes " (70) chapter	

9.3.5.2 Write request: Setting the deceleration time for quick stop (QSP)

In the controller, the deceleration time for quick stop (QSP) is to be set to 50 ms.

Code to be written: C00105

Parameter request

Byte 1	Byte 2	Byte 3	Byte 4
Request reference	Request identification	Axis	Number of indices
0xXX	0x02	0x00	0x01
	Write parameter	Axis 0	1 index

Byte 5	Byte 6
Attribute	Number of subindices
0x10	0x00
Value	No subindex

Byte 7	Byte 8	Byte 9	Byte 10
Index		Subindex	
High byte	Low byte	High byte	Low byte
0x5F	0x96	0x00	0x00
Index = 24575 - code no. = 24575 - 105 = 24470 = 0x5F 96		No subindex	

Byte 11	Byte 12
Format	Number of values
0x43	0x01
Double word	1 value

Byte 13	Byte 14	Byte 15	Byte 16
Value			
High word: high byte	High word: low byte	Low- word: high byte	Low word: low byte
0x00	0x00	0x00	0x32
Value to be written = 0.05 [s] x 1000 (internal factor) = 50 = 0x00 00 00 32			

Parameter response to a correctly executed write request

Byte 1	Byte 2	Byte 3	Byte 4
Request reference (mirrored)	Response identification	Axis (mirrored)	Number of indices
0xXX	0x02	0x00	0x01
	Parameter has been written		1 index

Parameter response to a read error

Byte 1	Byte 2	Byte 3	Byte 4
Request reference (mirrored)	Response identification	Axis (mirrored)	Number of indices
0xXX	0x82	0x00	0x01
	Parameter has not been written		1 index

Byte 5	Byte 6
Format	Number of values
0x44	0x01
Error	Error code without additional information

Byte 7	Byte 8
Error code	
High byte	Low byte
For the meaning, see Error codes (70)	

9.4 Consistent parameter data

In the PROFIBUS communication system, data are permanently exchanged between the host (CPU + PROFIBUS master) and the standard device via the plugged-on communication module. Both the PROFIBUS master and the CPU (central processing unit) of the host access a joint memory: the dual port memory (DPM).

The DPM permits a data exchange in both directions (write/read):



It could happen that a slower PROFIBUS master writing would be overtaken by a faster CPU reading within a cycle time without any further data organisation.

In order to avoid such an impermissible state, the parameter data to be transmitted must be marked as "consistent".

Data communication with consistent data

With consistency, either "reading" or "writing" is possible when the master and the CPU simultaneously access the memory:

- The PROFIBUS master transfers data only as a complete data set.
- The CPU can only access completely updated data sets.
- The PROFIBUS master cannot read or write data as long as the CPU accesses consistent data.

The result becomes clear from the example below:



1. As the master can only write if the CPU does not read, the master waits until the data are read completely by the CPU.
2. The master only writes a complete data set into DPM.

Configuring consistent data



Note!

Consistency is achieved by an appropriate PROFIBUS master configuration. For this purpose, refer to the documentation for your configuring software.

10 PROFIsafe

PROFIBUS enables the transfer of safe information via the PROFIsafe protocol in accordance with the "PROFIsafe - Profile for Safety Technology" specification, version 2.0.



Note!

A safety bus system (PROFIsafe) can only be operated via the upper module slot **MXI1** of the Servo Drive 9400.

- The PROFIsafe data are sent in the first slot of a PROFIBUS data telegram.
- One bit of the PROFIsafe data is always used to control specific safety functions.
- The structure of the PROFIsafe data is described in the PROFIsafe profile.
- The length of the PROFIsafe data (also called PROFIsafe message) always is 8 bytes.



Documentation for the safety module SM301 (E94AYAE)

Here you can find detailed information on the PROFIsafe connection.

11 Monitoring

11.1 Permanent interruption of PROFIBUS communication

If PROFIBUS communication is interrupted permanently, e.g. by cable breakage or failure of the PROFIBUS master, no process data are transmitted to the slave being in the "Data Exchange" state.

After the watchdog monitoring time determined by the PROFIBUS master has expired, the response parameterised under [C13880/1](#) / [C14880/1](#) is executed in the controller (slave).

The process data handling depends on the setting in [C13885](#) / [C14885](#). (The last data sent by the master can either be used or set to zero.)

Preconditions for a controller (slave) response

- A monitoring time of 1 ... 65534 ms is set for the "Data_Exchange" state ([C13881](#) / [C14881](#)).
A value of "65535 ms" (Lenze setting) deactivates the monitoring.
- A response is set for the slave in [C13880/1](#) / [C14880/1](#) (Lenze setting: "No response").
- The slave is in the "Data_Exchange" state.
- The watchdog monitoring time is configured correctly in the master.

If one of these preconditions is not met, the response to the absence of cyclic process data telegrams from the master is not executed.

▶ [Settings and displays in the »Engineer«](#) (📖 80)

11.2

Short-time interruption of PROFIBUS communication

From software version 01.21, the current DP states are displayed in [C13868](#) / [C14868](#).

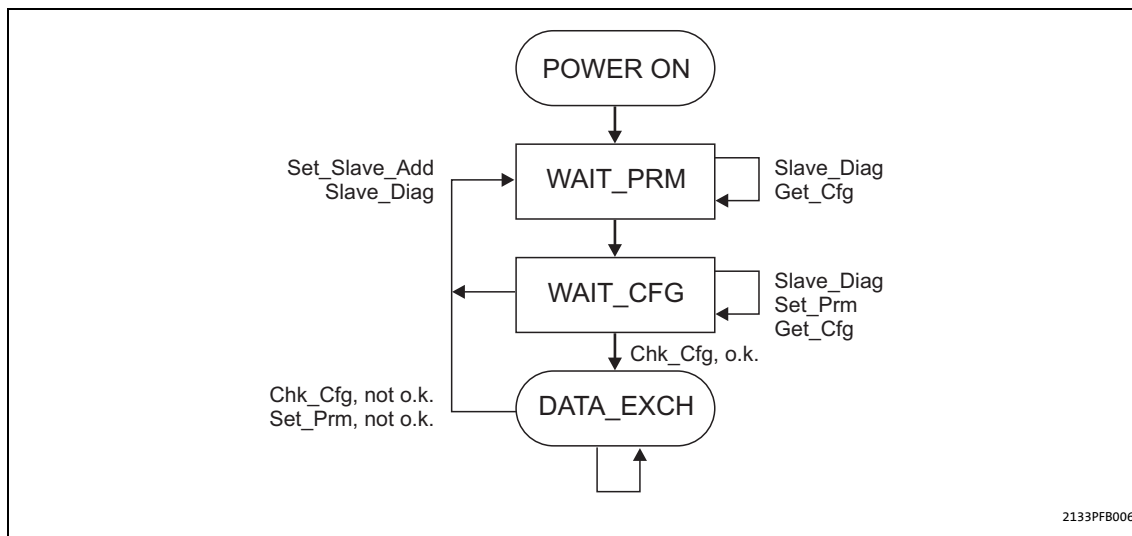

[11-1] DP states (Decentralized Peripherals) for short-time interruption of communication

The master detects the communication fault and transfers the slave to the "WAIT_PRM" state of the DP state machine after only a few microseconds (see Fig. [\[11-1\]](#)).

Only after the state chain of the DP state machine ending in the "Data_Exchange" state (DATA_EXCH) has been passed through, the watchdog monitoring time calculated for the slave (in milliseconds) continues to run.



Note!

The watchdog monitoring time does not continue to run when the slave does not reach the "Data_Exchange" state due to repeated communication errors (e.g. caused by loose contact).

Additional monitoring for the data exchange

An additional monitoring function for data exchange is available under [C13881](#) / [C14881](#). This monitoring function already becomes active when the "Data_Exchange" state is exited and the parameterised time (0 ... 65535 ms) has expired. The active monitoring function triggers the response parameterised under [C13880/1](#) / [C14880/1](#).



Note!

Observe the following condition for the time setting:

Monitoring time for data exchange ([C13881](#) / [C14881](#)) ≤ watchdog monitoring time of PROFIBUS ([C13882/1](#) / [C14882/1](#)).

11.3 Settings and displays in the »Engineer«

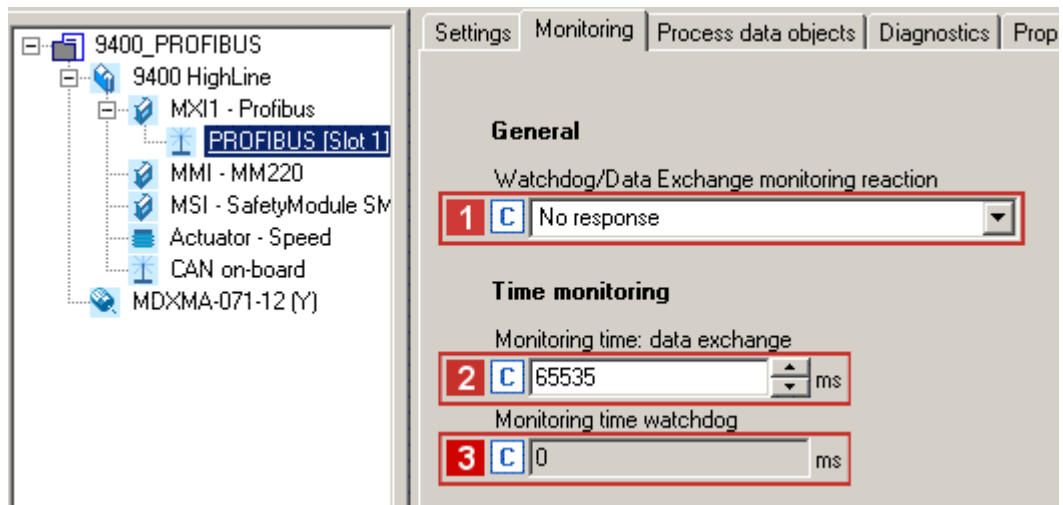

On the **Monitoring** tab of the »Engineer«, you can set or display the following parameters:

- Set a response **1** ([C13880/1](#) / [C14880/1](#)) to the interruption of communication.
- Set a monitoring time **2** ([C13881](#) / [C14881](#)) for the "Data_Exchange" state.
- The watchdog monitoring time specified in the master **3** ([C13882/1](#) / [C14882/1](#)).

11

Monitoring

11.4

Interruption of internal communication

11.4

Interruption of internal communication

The response to a communication error between the communication module and the standard device can be set via the standard device codes [C01501](#) (module in slot MXI1) and [C01502](#) (module in slot MXI2) ([📖 92](#)).

12 Diagnostics

12.1 LED status displays

12 Diagnostics

For diagnosing faults of the PROFIBUS module, the LEDs on the front panel are available. Furthermore, you can query the current bus status via codes [C13861](#) / [C14861](#).

12.1 LED status displays



Note!

During normal operation, the LED **BS** blinks and the LED **MS** is permanently lit.

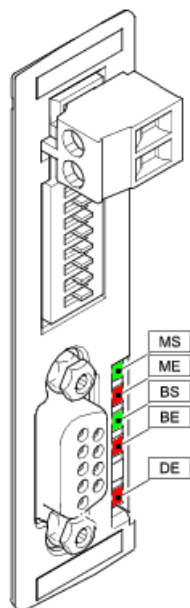
LED status display	Pos.	Colour	State	Description
	MS	Green	On	The communication module is supplied with voltage and has established a connection to the standard device.
			Blinking	The communication module is supplied with voltage, but has not yet established a connection to the standard device. (Standard device is switched off, initialising or not present.)
	ME	Red	On	An error concerning the communication module has occurred.
	BS	Green	Blinking	The communication module is in the DATA_EXCH state ("Data_Exchange"). Data are exchanged via the PROFIBUS.
			Off	The communication module is not active on the fieldbus or is being initialised.
	BE	Red	On	Bus error/fault is active (e.g. bus cable unplugged).
DE	Red	On	The communication module is not accepted by the standard device or the standard device is not active. (See notes in the documentation for the standard device.)	

12.2 Diagnostics with the »Engineer«

In the »Engineer«, the **Diagnostics** tab displays various pieces of PROFIBUS diagnostic information.

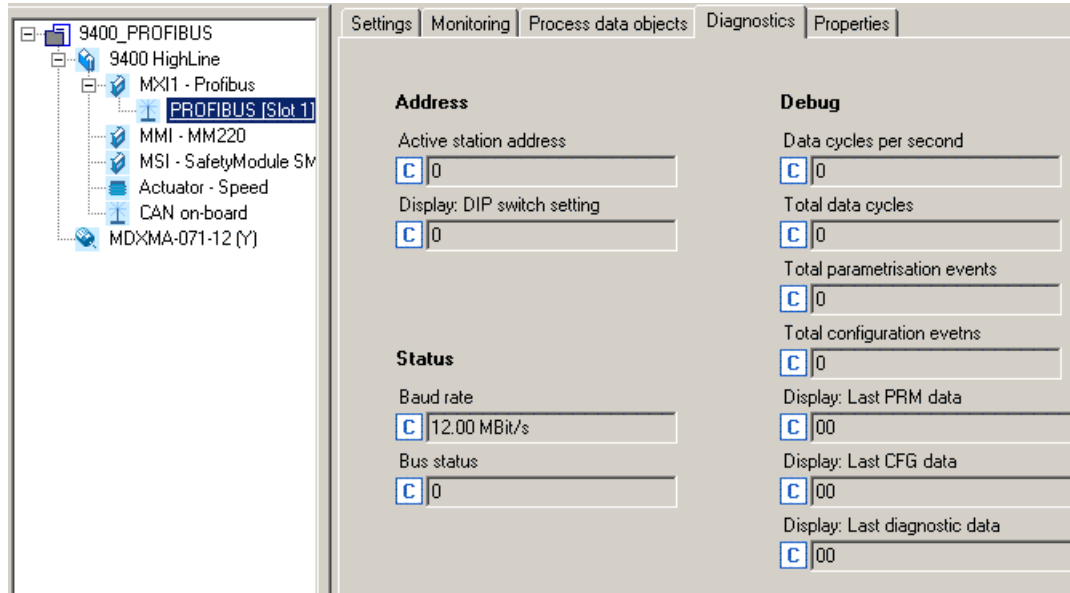

Querying the current bus status

[C13861](#) / [C14861](#) indicate the current PROFIBUS state in bit-coded form:

Bit assignment				Description
Bit 3	Bit 2	Bit 1	Bit 0	Reserved
		Bit 5	Bit 4	Status of the DP state machine (DP-STATE)
		0	0	WAIT_PRM The slave waits for a parameter data telegram after acceleration. Other types of telegrams will not be processed. Data exchange is not yet possible.
		0	1	WAIT_CFG The slave waits for the configuration telegram that specifies the number of input and output bytes. The master informs the slave about the number of I/O bytes that will be transferred.
		1	0	DATA_EXCH If the parameter settings as well as the configuration have been accepted by the firmware and by the application, the slave state changes to DATA_EXCH ("Data Exchange", exchange of user data with the master).
		1	1	Not possible
		Bit 7	Bit 6	Status of the watchdog state machine (WD-STATE)
		0	0	BAUD_SEARCH The PROFIBUS slave is able to detect the baud rate automatically.
		0	1	BAUD_CONTROL After recognising the correct baud rate, the slave status changes to BAUD_CONTROL and the baud rate is monitored.
		1	0	DP_CONTROL The DP_CONTROL state serves for response monitoring of the PROFIBUS master.
		1	1	Not possible
Bit 11	Bit 10	Bit 9	Bit 8	Detected PROFIBUS baud rate
0	0	0	0	12 Mbps
0	0	0	1	6 Mbps
0	0	1	0	3 Mbps
0	0	1	1	1.5 Mbps
0	1	0	0	500 kbps
0	1	0	1	187.5 kbps
0	1	1	0	93.75 kbps
0	1	1	1	45.45 kbps
1	0	0	0	19.2 kbps
1	0	0	1	9.6 kbps
Bit 15	Bit 14	Bit 13	Bit 12	Reserved

From software version 01.21, the current DP states are displayed in [C13868](#) / [C14868](#) (see fig. [\[11-1\]](#), chapter [Short-time interruption of PROFIBUS communication](#) (□ 79)).

12.3 Advanced diagnostic message

Errors in the standard device and its plugged-in modules are transmitted to the PROFIBUS master in the form of advanced diagnostic messages.

Structure of the diagnostic message

Byte	Description
1	Bit 0: Station does not exist (set by the master). Bit 1: Slave is not ready for data exchange. Bit 2: Configuration data do not correspond. Bit 3: Slave has extended diagnostic data. Bit 4: Requested function is not supported by the slave. Bit 5: Slave response is invalid (set by the master) Bit 6: Incorrect parameter setting Bit 7: Slave has been parameterised by another master (set by the master).
2	Bit 0: Slave must be parameterised again. Bit 1: Static diagnostics Bit 2: Permanently set to "1". Bit 3: Watchdog active Bit 4: Freeze command received. Bit 5: Sync command received. Bit 6: Reserved Bit 7: Slave is deactivated (set by the master).
3	Bit 7: Diagnostics overflow - amount of diagnostic information present in the slave is too large to fit into one telegram.
4	Bits 0 ... 7: Master address after parameter setting ("0xFF" without parameterisation)
5	Bits 0 ... 7: ID number (high byte)
6	Bits 0 ... 7: ID number (low byte)
7	Header <ul style="list-style-type: none"> The header contains the block length of the advanced diagnostics including the header byte. In this case, the value of the entry is "0x0A" (bytes 7 ... 16 = 10 bytes).
8	Status_Type The value of this entry is fixed. For the following bit assignment it is "0x81": <ul style="list-style-type: none"> Bit 7 = 1: "status" Bit 0 = 1: "status message" Value of all other bits = 0
9	Slot_Number The value of the slot number is "0x00".
10	Specifier <ul style="list-style-type: none"> A detected error is entered in the specifier with the identification "0x0" (status coming). An eliminated error is entered in the specifier with the identification "0x02" (status going). If no errors are indicated, the entry in the specifier has the value "0x00" (no further differentiation).
11	PROFIsafe, error number of the safety module SM301 (E94AYAE)
12	<ul style="list-style-type: none"> If an error occurs in the safety module, byte 11 (low byte) and byte 12 (high byte) contain the corresponding error number. See also documentation for the safety module.
13 ... 16	Error code of the Servo Drive 9400 <ul style="list-style-type: none"> Code C00168 can be used to read out the contents of the fault memory. Detailed information on the error codes of the Servo Drive 9400 can be found in the documentation of the controller.

12.3.1 Example 1: Error in parameter data "Incorrect PROFIsafe target address"

This error was caused while communication of the PROFIBUS master was established because the PROFIsafe target address configured in the PROFIBUS master does not correspond to the set address anymore.

Byte	Value [hex]	Description
1	x	Standard data (PRM_Fault)
...		
6		
7	0A	Block length of the advanced diagnostics = 10 bytes
8	81	Status message
9	00	Slot 0
10	01	Status coming
11	40	PROFIsafe error "0x0040" (64) GSG: "F address differ to F_Dest_Add"
12	00	
13	00	No other error message
...	...	
16	00	

12.3.2 Example 2: Error "Undervoltage in the DC bus" in the Servo Drive 9400

Byte	Value [hex]	Description	
1	x	Standard data (PRM_Fault)	
...			
6			
7	0A	Block length of the advanced diagnostics = 10 bytes	
8	81	Status message	
9	00	Slot 0	
10	01	Status coming	
11	00	No PROFIsafe/safety error	
12	00		
13	0F	Error message 0x447B000F "Undervoltage in DC bus"	
14	00		• Response: "Fault"
15	7B		• Instance ID: 1
16	44		• Module ID: 0x7B
		• Error ID: 0x0F	

13

Error messages

13.1

Short overview of the PROFIBUS error messages

13

Error messages

This chapter supplements the error list for the Servo Drive 9400 contained in the software manual and in the »Engineer« online help with the error messages of the communication module.



Software manual/online help for Servo Drive 9400

Here you can find general information on diagnostics & fault analysis and on error messages.

13.1

Short overview of the PROFIBUS error messages

The following table lists all PROFIBUS error messages in numerical order of the error number. Furthermore the preset error response and – if available – the parameters for setting the error response are specified.



Tip!

When you click the cross-reference in the first column, you will see a detailed description (causes and remedies) of this error message.

Error number		Designation	Response (Lenze setting)	Adjustable in
hex	dec			
0x00c83100	13119744	Profibus: Lost connection to 9400 base device	0: No response	-
0x00c85531	13129009	Profibus: No memory access	6: Information	-
0x00c85532	13129010	Profibus: Read memory error	6: Information	-
0x00c85533	13129011	Profibus: Write memory error	6: Information	-
0x00c86010	13131792	Profibus: Restart after watchdogreset	1: Fault	-
0x00c86011	13131793	Profibus: Internal error	1: Fault	-
0x00c86100	13132032	Profibus: Internal error	0: No response	-
0x00c86101	13132033	Profibus: Internal error	1: Fault	-
0x00c86110	13132048	Profibus: Internal mapping error	4: Warning locked	-
0x00c8641f	13132831	Profibus: Invalid parameter record	1: Fault	-
0x00c86420	13132832	Profibus: Error: Lenze setting loaded	1: Fault	-
0x00c88130	13140272	Profibus watchdog: Monitoring time elapsed	0: No response	C13880/1 C14880/1
0x00c88131	13140273	Profibus: Data_Exchange state exited	0: No response	C13880/1 C14880/1
0x00c88132	13140274	Profibus watchdog: DP-V1 MSAC2 elapsed	0: No response	C13880/2 C14880/2

13.2 Possible causes and remedies

This chapter lists all PROFIBUS error messages in the numerical order of the error numbers. Possible causes and remedies as well as responses to the error messages are described in detail.

Profibus: Lost connection to 9400 standard device [0x00c83100]

Response (Lenze setting printed in bold)	Setting: not possible
<input checked="" type="checkbox"/> None <input type="checkbox"/> System fault <input type="checkbox"/> Fault <input type="checkbox"/> Trouble <input type="checkbox"/> Quick stop by trouble <input type="checkbox"/> Warning locked <input type="checkbox"/> Warning <input type="checkbox"/> Information	
Cause	Remedy
<ul style="list-style-type: none"> • Network cable (plug) is defective. • Network cable is not connected to the PROFIBUS terminal X201. • Voltage supply is interrupted. 	<p>Check cables and terminals. Connect network cable to the PROFIBUS terminal X201.</p>

Profibus: No memory access [0x00c85531]

Response (Lenze setting printed in bold)	Setting: not possible
<input type="checkbox"/> None <input type="checkbox"/> System fault <input type="checkbox"/> Fault <input type="checkbox"/> Trouble <input type="checkbox"/> Quick stop by trouble <input type="checkbox"/> Warning locked <input type="checkbox"/> Warning <input checked="" type="checkbox"/> Information	
Cause	Remedy
Access to memory was not possible.	Repeat the download of the application (including module)

Profibus: Read memory error [0x00c85532]

Response (Lenze setting printed in bold)	Setting: not possible
<input type="checkbox"/> None <input type="checkbox"/> System fault <input type="checkbox"/> Fault <input type="checkbox"/> Trouble <input type="checkbox"/> Quick stop by trouble <input type="checkbox"/> Warning locked <input type="checkbox"/> Warning <input checked="" type="checkbox"/> Information	
Cause	Remedy
Parameter could not be read.	Repeat the download of the application (including module)

Profibus: Write memory error [0x00c85533]

Response (Lenze setting printed in bold)	Setting: not possible
<input type="checkbox"/> None <input type="checkbox"/> System fault <input type="checkbox"/> Fault <input type="checkbox"/> Trouble <input type="checkbox"/> Quick stop by trouble <input type="checkbox"/> Warning locked <input type="checkbox"/> Warning <input checked="" type="checkbox"/> Information	
Cause	Remedy
Parameter could not be written.	Repeat the download of the application (including module)

Profibus: Restart after watchdog reset [0x00c86010]

Response (Lenze setting printed in bold)	Setting: not possible
<input type="checkbox"/> None <input type="checkbox"/> System fault <input checked="" type="checkbox"/> Fault <input type="checkbox"/> Trouble <input type="checkbox"/> Quick stop by trouble <input type="checkbox"/> Warning locked <input type="checkbox"/> Warning <input type="checkbox"/> Information	
Cause	Remedy
Module defective.	If this occurs repeatedly, contact the Lenze service.

Profibus: Internal error [0x00c86011]

Response (Lenze setting printed in bold)	Setting: not possible
<input type="checkbox"/> None <input type="checkbox"/> System fault <input checked="" type="checkbox"/> Fault <input type="checkbox"/> Trouble <input type="checkbox"/> Quick stop by trouble <input type="checkbox"/> Warning locked <input type="checkbox"/> Warning <input type="checkbox"/> Information	
Cause	Remedy
Module defective.	If this occurs repeatedly, contact the Lenze service.

Profibus: Internal error [0x00c86100]

Response (Lenze setting printed in bold)	Setting: not possible
<input checked="" type="checkbox"/> None <input type="checkbox"/> System fault <input type="checkbox"/> Fault <input type="checkbox"/> Trouble <input type="checkbox"/> Quick stop by trouble <input type="checkbox"/> Warning locked <input type="checkbox"/> Warning <input type="checkbox"/> Information	
Cause	Remedy
Internal error.	If this occurs repeatedly, contact the Lenze service.

Profibus: Internal error [0x00c86101]

Response (Lenze setting printed in bold)	Setting: not possible
<input type="checkbox"/> None <input type="checkbox"/> System fault <input checked="" type="checkbox"/> Fault <input type="checkbox"/> Trouble <input type="checkbox"/> Quick stop by trouble <input type="checkbox"/> Warning locked <input type="checkbox"/> Warning <input type="checkbox"/> Information	
Cause	Remedy
The communication module carries out an automatic software reset and reinitialises itself.	If this occurs repeatedly, contact the Lenze service.

Profibus: Internal mapping error [0x00c86110]

Response (Lenze setting printed in bold)	Setting: not possible
<input type="checkbox"/> None <input type="checkbox"/> System fault <input type="checkbox"/> Fault <input type="checkbox"/> Trouble <input type="checkbox"/> Quick stop by trouble <input checked="" type="checkbox"/> Warning locked <input type="checkbox"/> Warning <input type="checkbox"/> Information	
Cause	Remedy
The selected PDO mapping is invalid: <ul style="list-style-type: none"> • An object not supporting the required properties has been specified. • More than 64 bytes of data have been mapped. 	Repeat the PDO mapping.

Profibus: Invalid parameter set [0x00c8641f]

Response (Lenze setting printed in bold)	Setting: not possible
<input type="checkbox"/> None <input type="checkbox"/> System fault <input checked="" type="checkbox"/> Fault <input type="checkbox"/> Trouble <input type="checkbox"/> Quick stop by trouble <input type="checkbox"/> Warning locked <input type="checkbox"/> Warning <input type="checkbox"/> Information	
Cause	Remedy
No active parameter set could be loaded.	Repeat the download of the application (including module)

Profibus: Error: Lenze setting loaded [0x00c86420]

Response (Lenze setting printed in bold)	Setting: not possible
<input type="checkbox"/> None <input type="checkbox"/> System fault <input checked="" type="checkbox"/> Fault <input type="checkbox"/> Trouble <input type="checkbox"/> Quick stop by trouble <input type="checkbox"/> Warning locked <input type="checkbox"/> Warning <input type="checkbox"/> Information	
Cause	Remedy
Access to parameter set was not successful.	Repeat the download of the application (including module).

Profibus watchdog: Monitoring time elapsed [0x00c88130]

Response (Lenze setting printed in bold)	Setting: C13880/1 / C14880/1 (☑ Adjustable response)
☑ None <input type="checkbox"/> System fault <input checked="" type="checkbox"/> Fault <input type="checkbox"/> Trouble <input checked="" type="checkbox"/> Quick stop by trouble <input checked="" type="checkbox"/> Warning locked <input type="checkbox"/> Warning <input checked="" type="checkbox"/> Information	
Cause	Remedy
Permanent interruption of communication to the PROFIBUS master. See also chapter " Permanent interruption of PROFIBUS communication " (📖 78).	Check cables and terminals.

Profibus: Data_Exchange state exited [0x00c88131]

Response (Lenze setting printed in bold)	Setting: C13880/1 / C14880/1 (☑ Configurable response)
☑ None <input type="checkbox"/> System fault <input checked="" type="checkbox"/> Fault <input type="checkbox"/> Trouble <input checked="" type="checkbox"/> Quick stop by trouble <input checked="" type="checkbox"/> Warning locked <input type="checkbox"/> Warning <input checked="" type="checkbox"/> Information	
Cause	Remedy
Data exchange via PROFIBUS has been terminated. See also chapter " Permanent interruption of PROFIBUS communication " (📖 78).	Check cables and terminals. The slave must receive new parameterisation and configuration files from the master in order to be able to exchange data again.

Profibus watchdog: DP-V1 MSAC2 elapsed [0x00c88132]

Response (Lenze setting printed in bold)	Setting: C13880/2 / C14880/2 (☑ Configurable response)
☑ None <input type="checkbox"/> System fault <input checked="" type="checkbox"/> Fault <input type="checkbox"/> Trouble <input checked="" type="checkbox"/> Quick stop by trouble <input checked="" type="checkbox"/> Warning locked <input type="checkbox"/> Warning <input checked="" type="checkbox"/> Information	
Cause	Remedy
Permanent interruption of communication to C2-PROFIBUS master. See also chapter " Permanent interruption of PROFIBUS communication " (📖 78).	Check cables and terminals.

14 Parameter reference

14.1 Communication-relevant parameters of the standard device

14 Parameter reference

This chapter supplements the parameter list and the table of attributes contained in the software manual and in the »Engineer« online help for the Servo Drive 9400 with the parameters of the E94AYCPM (PROFIBUS) communication module.



Software manual/»Engineer« online help for Servo Drive 9400

Here you can find general information on parameters.

14.1 Communication-relevant parameters of the standard device

This chapter lists the communication-relevant parameters of the Servo Drive 9400 in numerically ascending order.

C00615

Parameter Name:		Data type: UNSIGNED_32 Index: 23960 _d = 5D98 _h
C00615 Resp. to imp. device conf.		
Response to incorrect device configuration		
Selection list		
1	Error	
3	Quick stop by trouble	
4	Warning locked	
6	Information	
0	No response	
Subcodes		
Lenze setting	Info	
C00615/1	0: No response	Reserved
C00615/2	1: Fault	Resp. to imp. module in MXI1
C00615/3	1: Fault	Resp. to imp. module in MXI2
C00615/4	0: No response	Reserved
C00615/5	0: No response	Reserved
<input checked="" type="checkbox"/> Read access <input checked="" type="checkbox"/> Write access <input type="checkbox"/> CINH <input type="checkbox"/> PLC-STOP <input type="checkbox"/> No transfer		

C00636

Parameter Name:		Data type: UNSIGNED_32 Index: 23939 _d = 5D83 _h
C00636 Resp. to new module in MXI1		
Response when a new module has been inserted in module slot 1 of the standard device.		
Selection list (Lenze setting printed in bold)		
1	Error	
6	Information	
5	Warning	
4	Warning locked	
3	Quick stop by trouble	
0	No response	
<input checked="" type="checkbox"/> Read access <input checked="" type="checkbox"/> Write access <input type="checkbox"/> CINH <input type="checkbox"/> PLC-STOP <input type="checkbox"/> No transfer		

C00637

Parameter Name: C00637 Resp. to new module in MXI2		Data type: UNSIGNED_32 Index: 23939 _d = 5D83 _h
Response when a new module has been inserted in module slot 2 of the standard device.		
Selection list (Lenze setting printed in bold)		
1	Error	
6	Information	
5	Warning	
4	Warning locked	
3	Quick stop by trouble	
0	No response	
<input checked="" type="checkbox"/> Read access <input checked="" type="checkbox"/> Write access <input type="checkbox"/> CINH <input type="checkbox"/> PLC-STOP <input type="checkbox"/> No transfer		

C01501

Parameter Name: C01501 Resp. to comm. error with MXI1		Data type: UNSIGNED_32 Index: 23074 _d = 5A22 _h
Response to a communication error between an "intelligent" module in module slot 1 and the standard device		
Selection list (Lenze setting printed in bold)		
0	No response	
1	Error	
3	Quick stop by trouble	
4	Warning locked	
5	Warning	
<input checked="" type="checkbox"/> Read access <input checked="" type="checkbox"/> Write access <input type="checkbox"/> CINH <input type="checkbox"/> PLC-STOP <input type="checkbox"/> No transfer		

C01502

Parameter Name: C01502 Resp. to comm. error with MXI2		Data type: UNSIGNED_32 Index: 23074 _d = 5A22 _h
Response to a communication error between an "intelligent" module in module slot 2 and the standard device		
Selection list (Lenze setting printed in bold)		
0	No response	
1	Error	
3	Quick stop by trouble	
4	Warning locked	
5	Warning	
<input checked="" type="checkbox"/> Read access <input checked="" type="checkbox"/> Write access <input type="checkbox"/> CINH <input type="checkbox"/> PLC-STOP <input type="checkbox"/> No transfer		

14 Parameter reference

14.2 Parameters of the communication module for slot MXI1

14.2 Parameters of the communication module for slot MXI1

This chapter lists the parameters of the E94AYCPM communication module (PROFIBUS) for slot MXI2 of the Servo Drive 9400 in numerically ascending order.

C13231

Parameter Name: C13231 Service code	Data type: UNSIGNED_64 Index: 11344 _d = 2C50 _h
This code is for device-internal use only and must not be overwritten by the user!	

C13489

Parameter Name: C13489 Service code	Data type: UNSIGNED_8 Index: 11086 _d = 2B4E _h
This code is for device-internal use only and must not be overwritten by the user!	

C13531

Parameter Name: C13531 Service code	Data type: UNSIGNED_64 Index: 11044 _d = 2B24 _h
This code is for device-internal use only and must not be overwritten by the user!	

C13789

Parameter Name: C13789 Service code	Data type: UNSIGNED_8 Index: 10786 _d = 2A22 _h
This code is for device-internal use only and must not be overwritten by the user!	

C13850

Parameter Name: C13850 All words to master	Data type: UNSIGNED_16 Index: 10725 _d = 29E5 _h
Display of the process data words transferred from the communication module to the PROFIBUS master. In the subcodes 1 ... 32, all process data words to the master are displayed. Only the configured process data words are valid.	
Display area (min. value unit max. value)	
0	65535
Subcodes	Info
C13850/1	
...	
C13850/32	
<input checked="" type="checkbox"/> Read access <input type="checkbox"/> Write access <input type="checkbox"/> CINH <input type="checkbox"/> PLC-STOP <input type="checkbox"/> No transfer <input type="checkbox"/> PDO_MAP_RX <input type="checkbox"/> PDO_MAP_TX <input type="checkbox"/> COM <input type="checkbox"/> MOT	

C13851

Parameter Name: C13851 All words from master		Data type: UNSIGNED_16 Index: 10724 _d = 29E4 _h
Display of the process data words transferred from the PROFIBUS master to the communication module. In the subcodes 1 ... 32, all process data words to the master are displayed. Only the configured process data words are valid.		
Display area (min. value unit max. value)		
0		65535
Subcodes		Info
C13851/1		
...		
C13851/32		
<input checked="" type="checkbox"/> Read access <input type="checkbox"/> Write access <input type="checkbox"/> CINH <input type="checkbox"/> PLC-STOP <input type="checkbox"/> No transfer <input type="checkbox"/> PDO_MAP_RX <input type="checkbox"/> PDO_MAP_TX <input type="checkbox"/> COM <input type="checkbox"/> MOT		

C13852

Parameter Name: C13852 All words to standard device		Data type: UNSIGNED_16 Index: 10723 _d = 29E3 _h
Display of the process data words 1 ... 32 transferred from the communication module to the standard device. In the subcodes 1 ... 32, all process data words from the communication module are displayed.		
Display area (min. value unit max. value)		
0		65535
Subcodes		Info
C13852/1		
...		
C13852/32		
<input checked="" type="checkbox"/> Read access <input type="checkbox"/> Write access <input type="checkbox"/> CINH <input type="checkbox"/> PLC-STOP <input type="checkbox"/> No transfer <input type="checkbox"/> PDO_MAP_RX <input type="checkbox"/> PDO_MAP_TX <input type="checkbox"/> COM <input type="checkbox"/> MOT		

C13853

Parameter Name: C13853 All words from standard device		Data type: UNSIGNED_16 Index: 10722 _d = 29E2 _h
Display of the process data words 1 ... 32 transferred from the standard device to the communication module. In the subcodes 1 ... 32, all process data words from the standard device are displayed.		
Display area (min. value unit max. value)		
0		65535
Subcodes		Info
C13853/1		
...		
C13853/32		
<input checked="" type="checkbox"/> Read access <input type="checkbox"/> Write access <input type="checkbox"/> CINH <input type="checkbox"/> PLC-STOP <input type="checkbox"/> No transfer <input type="checkbox"/> PDO_MAP_RX <input type="checkbox"/> PDO_MAP_TX <input type="checkbox"/> COM <input type="checkbox"/> MOT		

C13854

Parameter Name: C13854 COM word to standard device		Data type: BITFIELD_32 Index: 10721 _d = 29E1 _h
Available from software version 01.21! This code is for device-internal use only and must not be overwritten by the user!		

C13855

Parameter Name: C13855 COM word from standard device	Data type: BITFIELD_32 Index: 10720 _d = 29E0 _h
Available from software version 01.21! This code is for device-internal use only and must not be overwritten by the user!	

C13860

Parameter Name: C13860 Settings	Data type: UNSIGNED_8 Index: 10715 _d = 29DB _h
Display of the current configuration data.	
Display area (min. value unit max. value)	
0	255
Subcodes	Info
C13860/1	PROFIsafe • 0: Not active • 1: Active
C13860/2	Number of process data words (1 ... 32 words)
C13860/3	DRIVECOM parameter data channel • 0: Not active • 1: Active
C13860/4	Number of PROFIsafe words (0 or 4 words)
<input checked="" type="checkbox"/> Read access <input type="checkbox"/> Write access <input type="checkbox"/> CINH <input type="checkbox"/> PLC-STOP <input type="checkbox"/> No transfer <input type="checkbox"/> PDO_MAP_RX <input type="checkbox"/> PDO_MAP_TX <input type="checkbox"/> COM <input type="checkbox"/> MOT	

C13861

Parameter Name: C13861 Bus status	Data type: UNSIGNED_16 Index: 10714 _d = 29DA _h
Bit-coded display of the current bus state. ▶ Querying the current bus status (□ 84)	
Display area (min. value unit max. value)	
0	65535
<input checked="" type="checkbox"/> Read access <input type="checkbox"/> Write access <input type="checkbox"/> CINH <input type="checkbox"/> PLC-STOP <input type="checkbox"/> No transfer <input type="checkbox"/> PDO_MAP_RX <input type="checkbox"/> PDO_MAP_TX <input type="checkbox"/> COM <input type="checkbox"/> MOT	

C13862

Parameter Name: C13862 Bus counter	Data type: UNSIGNED_16 Index: 10713 _d = 29D9 _h
When the maximum count value of 65535 is reached, the counter starts again with 0.	
Display area (min. value unit max. value)	
0	65535
Subcodes	Info
C13862/1	Data cycles per second
C13862/2	Total data cycles
C13862/3	Total parameterisation events
C13862/4	Total configuration events
<input checked="" type="checkbox"/> Read access <input type="checkbox"/> Write access <input type="checkbox"/> CINH <input type="checkbox"/> PLC-STOP <input type="checkbox"/> No transfer <input type="checkbox"/> PDO_MAP_RX <input type="checkbox"/> PDO_MAP_TX <input type="checkbox"/> COM <input type="checkbox"/> MOT	

C13863

Parameter Name: C13863 Baud rate		Data type: UNSIGNED_8 Index: 10712 _d = 29D8 _h
Display of the baud rate		
Selection list (read only)		
0	12.00 Mbps	
1	6.00 Mbps	
2	3.00 Mbps	
3	1.50 Mbps	
4	500.00 kbps	
5	187.50 kbps	
6	93.75 kbps	
7	45.45 kbps	
8	19.20 kbps	
9	9.60 kbps	
15	No baud rate detected	
<input checked="" type="checkbox"/> Read access <input type="checkbox"/> Write access <input type="checkbox"/> CINH <input type="checkbox"/> PLC-STOP <input type="checkbox"/> No transfer <input type="checkbox"/> PDO_MAP_RX <input type="checkbox"/> PDO_MAP_TX <input type="checkbox"/> COM <input type="checkbox"/> MOT		

C13864

Parameter Name: C13864 Active station address		Data type: UNSIGNED_8 Index: 10711 _d = 29D7 _h
Display of the active station address		
If all DIP switches 1 ... 64 are in the "OFF" position (Lenze setting), the station address set in C13899 becomes active and is displayed here after switching on.		
▶ Setting the station address (□ 31)		
Display area (min. value unit max. value)		
0		255
<input checked="" type="checkbox"/> Read access <input type="checkbox"/> Write access <input type="checkbox"/> CINH <input type="checkbox"/> PLC-STOP <input type="checkbox"/> No transfer <input type="checkbox"/> PDO_MAP_RX <input type="checkbox"/> PDO_MAP_TX <input type="checkbox"/> COM <input type="checkbox"/> MOT		

C13865

Parameter Name: C13865 Display: Most recent PRM data		Data type: OCTET_STRING Index: 10710 _d = 29D6 _h
Display of the last parameter data sent by the PROFIBUS master with the "Set-Prm" telegram (ASCII string with 24 characters)		
<input checked="" type="checkbox"/> Read access <input type="checkbox"/> Write access <input type="checkbox"/> CINH <input type="checkbox"/> PLC-STOP <input type="checkbox"/> No transfer <input type="checkbox"/> PDO_MAP_RX <input type="checkbox"/> PDO_MAP_TX <input type="checkbox"/> COM <input type="checkbox"/> MOT		

C13866

Parameter Name: C13866 Display: Most recent CFG data		Data type: OCTET_STRING Index: 10709 _d = 29D5 _h
Display of the last configuration data sent by the PROFIBUS master with the "Chk-Cfg" telegram (ASCII string with 22 characters)		
<input checked="" type="checkbox"/> Read access <input type="checkbox"/> Write access <input type="checkbox"/> CINH <input type="checkbox"/> PLC-STOP <input type="checkbox"/> No transfer <input type="checkbox"/> PDO_MAP_RX <input type="checkbox"/> PDO_MAP_TX <input type="checkbox"/> COM <input type="checkbox"/> MOT		

C13867

Parameter Name: C13867 Display: Most recent diagnostic data	Data type: OCTET_STRING Index: 10708 _d = 29D4 _h
Display of the last diagnostic data sent to the PROFIBUS master (ASCII string with 16 characters) ▶ Advanced diagnostic message (□ 85)	
<input checked="" type="checkbox"/> Read access <input type="checkbox"/> Write access <input type="checkbox"/> CINH <input type="checkbox"/> PLC-STOP <input type="checkbox"/> No transfer <input type="checkbox"/> PDO_MAP_RX <input type="checkbox"/> PDO_MAP_TX <input type="checkbox"/> COM <input type="checkbox"/> MOT	

C13868

Parameter Name: C13868 Display: DP state	Data type: UNSIGNED_8 Index: 10707 _d = 29D3 _h
Available from software version 01.21! Display of the DP states (Decentralized Peripherals) ▶ Short-time interruption of PROFIBUS communication (□ 79), see fig. [11-1]	
Selection list (read only)	
0	Waiting for parameterisation
1	Waiting for configuration
2	Data exchange
3	n/a
<input checked="" type="checkbox"/> Read access <input type="checkbox"/> Write access <input type="checkbox"/> CINH <input type="checkbox"/> PLC-STOP <input type="checkbox"/> No transfer <input type="checkbox"/> PDO_MAP_RX <input type="checkbox"/> PDO_MAP_TX <input type="checkbox"/> COM <input type="checkbox"/> MOT	

C13880

Parameter Name: C13880 Reaction on communication fault	Data type: UNSIGNED_8 Index: 10695 _d = 29C7 _h	
Monitoring response to a communication fault on the PROFIBUS A change in the monitoring response is effective immediately. ▶ Permanent interruption of PROFIBUS communication (□ 78)		
Selection list		
0	No response	
1	Error	
3	Quick stop by trouble	
4	Warning locked	
6	Information	
Subcodes	Lenze setting	Info
C13880/1	0: No response	The response set here for the "Watchdog/Data Exchange" monitoring function is executed if the bus station ... <ul style="list-style-type: none"> • does not receive a message from the master within the watchdog monitoring time (displayed in C13882/1) if there is an active connection. • detects that it is no longer in the "Data_Exchange" status. Please see also the notes given under C13881.
C13880/2	0: No response	The response set here for the "DPV1 MSAC2" monitoring is executed if the bus station does not receive a "DPV1 MSAC2" message from the master within the monitoring time (displayed in C13882/2) if there is an active connection) and the MSAC2 connection is stopped by the slave. Note: We recommend only setting "information" as response so that no drive-relevant response is executed.
<input checked="" type="checkbox"/> Read access <input checked="" type="checkbox"/> Write access <input type="checkbox"/> CINH <input type="checkbox"/> PLC-STOP <input type="checkbox"/> No transfer <input type="checkbox"/> PDO_MAP_RX <input type="checkbox"/> PDO_MAP_TX <input type="checkbox"/> COM <input type="checkbox"/> MOT		

C13881

Parameter Name: C13881 Monitoring time: Data exchange		Data type: UNSIGNED_16 Index: 10694 _d = 29C6 _h
<p>If the "Data Exchange" state is exited, the response parameterised under C13880/1 is carried out when the monitoring time for data exchange set here has expired.</p> <ul style="list-style-type: none"> • A value of "65535" in this code deactivates the monitoring function. • A change in monitoring is effective immediately. • The value set here for the monitoring time must be smaller than the watchdog monitoring time (C13882/1). <p>▶ Permanent interruption of PROFIBUS communication (78)</p>		
Setting range (min. value unit max. value)		Lenze setting
0	ms	65535
		65535 ms
<input checked="" type="checkbox"/> Read access <input checked="" type="checkbox"/> Write access <input type="checkbox"/> CINH <input type="checkbox"/> PLC-STOP <input type="checkbox"/> No transfer <input type="checkbox"/> PDO_MAP_RX <input type="checkbox"/> PDO_MAP_TX <input type="checkbox"/> COM <input type="checkbox"/> MOT		

C13882

Parameter Name: C13882 Monitoring time: Watchdog		Data type: UNSIGNED_32 Index: 10693 _d = 29C5 _h
<p>Display of the watchdog monitoring time determined by the PROFIBUS master</p> <ul style="list-style-type: none"> • A change in the watchdog monitoring time is immediately effective. • Monitoring starts with the receipt of the first telegram. • When a value of "0" is displayed, the monitoring function is deactivated. <p>▶ Permanent interruption of PROFIBUS communication (78)</p>		
Display area (min. value unit max. value)		
0	ms	4294967295
Subcodes		Info
C13882/1		Watchdog monitoring time
C13882/2		DP-V1 MSC2
<input checked="" type="checkbox"/> Read access <input type="checkbox"/> Write access <input type="checkbox"/> CINH <input type="checkbox"/> PLC-STOP <input type="checkbox"/> No transfer <input type="checkbox"/> PDO_MAP_RX <input type="checkbox"/> PDO_MAP_TX <input type="checkbox"/> COM <input type="checkbox"/> MOT		

C13885

Parameter Name: C13885 Clear process data		Data type: UNSIGNED_8 Index: 10690 _d = 29C2 _h
<p>Selection of the process data which the controller will process in the event of a PROFIBUS failure in order to maintain internal communication.</p>		
Selection list (Lenze setting printed in bold)		
0	Use of most recent master PDOs	
1	PDOs are set to the value '0'	
<input checked="" type="checkbox"/> Read access <input checked="" type="checkbox"/> Write access <input type="checkbox"/> CINH <input type="checkbox"/> PLC-STOP <input type="checkbox"/> No transfer <input type="checkbox"/> PDO_MAP_RX <input type="checkbox"/> PDO_MAP_TX <input type="checkbox"/> COM <input type="checkbox"/> MOT		

C13886

Parameter Name: C13886 Set ext. diagnostic bit upon		Data type: BITFIELD_8 Index: 10689 _d = 29C1 _h
<p>Bit-coded selection of the error responses in the standard device causing the external diagnostic bit ("diag bit") to be set (see PROFIBUS specification; bit 3 of byte 1 of the DP diagnostic messages).</p> <ul style="list-style-type: none"> • The diagnostic bit is sent to the PROFIBUS master where it is evaluated separately. • The diagnostic bit is always set when a system error occurs. • The Lenze setting "0" means that the diagnostic bit is not set for the following error responses. • An advanced diagnostic message is always sent. 		
Value is bit-coded:		
Bit 0	Error	
Bit 1	Trouble	
Bit 2	Quick stop by trouble	
Bit 3	Warning locked	
Bit 4	Warning	
Bit 5	Reserved	
Bit 6	Reserved	
Bit 7	Reserved	
<input checked="" type="checkbox"/> Read access <input checked="" type="checkbox"/> Write access <input type="checkbox"/> CINH <input type="checkbox"/> PLC-STOP <input type="checkbox"/> No transfer <input type="checkbox"/> PDO_MAP_RX <input type="checkbox"/> PDO_MAP_TX <input type="checkbox"/> COM <input type="checkbox"/> MOT		

C13887

Parameter Name: C13887 Suppress signalling diag. mess. upon		Data type: BITFIELD_8 Index: 10688 _d = 29C0 _h
<p>Available from software version 01.20!</p> <p>Selection of the error responses not causing a diagnostic request to the PROFIBUS master. A diagnostic request is always signalled if a system error or an error message from the SM301 (E94AYAE) safety module occurs.</p> <p>The Lenze setting "0" means that for each of the following error responses a diagnostic request is signalled.</p>		
Value is bit-coded:		Info
Bit 0	Error	
Bit 1	Trouble	
Bit 2	Quick stop by trouble	
Bit 3	Warning locked	
Bit 4	Warning	
Bit 5	Reserved	
Bit 6	Reserved	
Bit 7	Error message 0x00c88130	<p>Available from software version 01.21!</p> <p>Selective suppression of the error message "Available connection to 9400 standard device lost"</p>
<input checked="" type="checkbox"/> Read access <input checked="" type="checkbox"/> Write access <input type="checkbox"/> CINH <input type="checkbox"/> PLC-STOP <input type="checkbox"/> No transfer <input type="checkbox"/> PDO_MAP_RX <input type="checkbox"/> PDO_MAP_TX <input type="checkbox"/> COM <input type="checkbox"/> MOT		

C13897

Parameter Name: C13897 PROFIsafe: Target address		Data type: UNSIGNED_16 Index: 10678 _d = 29B6 _h
Setting of the PROFIsafe target address <ul style="list-style-type: none"> • Only required if the SM301 (E94AYAE) safety module is used. • A unique PROFIsafe target address must be assigned to each controller. 		
Setting range (min. value unit max. value)		Lenze setting
1		65534 1
<input checked="" type="checkbox"/> Read access <input checked="" type="checkbox"/> Write access <input type="checkbox"/> CINH <input type="checkbox"/> PLC-STOP <input type="checkbox"/> No transfer <input type="checkbox"/> PDO_MAP_RX <input type="checkbox"/> PDO_MAP_TX <input checked="" type="checkbox"/> COM <input type="checkbox"/> MOT		

C13899

Parameter Name: C13899 Station address		Data type: UNSIGNED_8 Index: 10676 _d = 29B4 _h
Optional setting of the station address (instead of setting via DIP switches 1 ... 64) <ul style="list-style-type: none"> • The station address set here only becomes effective if the DIP switches 1 ... 64 have been set to OFF prior to mains switching. • The active station address is displayed under C13864. Note: A change of the station address will not be effective until the "Save parameter set" device command has been executed and another mains switching for the communication module/controller has been performed. ▶ Setting the station address (□ 31)		
Setting range (min. value unit max. value)		Lenze setting
3		126 3
<input checked="" type="checkbox"/> Read access <input checked="" type="checkbox"/> Write access <input type="checkbox"/> CINH <input type="checkbox"/> PLC-STOP <input type="checkbox"/> No transfer <input type="checkbox"/> PDO_MAP_RX <input type="checkbox"/> PDO_MAP_TX <input checked="" type="checkbox"/> COM <input type="checkbox"/> MOT		

C13900

Parameter Name: C13900 Firmware product type		Data type: VISIBLE_STRING Index: 10675 _d = 29B3 _h
Display of the product type (string with a length of 8 bytes) The following identification code is displayed: "E94AFCPM".		
<input checked="" type="checkbox"/> Read access <input type="checkbox"/> Write access <input type="checkbox"/> CINH <input type="checkbox"/> PLC-STOP <input type="checkbox"/> No transfer <input type="checkbox"/> PDO_MAP_RX <input type="checkbox"/> PDO_MAP_TX <input type="checkbox"/> COM <input type="checkbox"/> MOT		

C13901

Parameter Name: C13901 Firmware compilation date		Data type: VISIBLE_STRING Index: 10674 _d = 29B2 _h
Display of the compilation date of the firmware (string with a length of 20 bytes) The date ("MMM DD YYYY") and time ("hh:mm:ss") are displayed, e.g. "Mar 21 2005 12:31:21".		
<input checked="" type="checkbox"/> Read access <input type="checkbox"/> Write access <input type="checkbox"/> CINH <input type="checkbox"/> PLC-STOP <input type="checkbox"/> No transfer <input type="checkbox"/> PDO_MAP_RX <input type="checkbox"/> PDO_MAP_TX <input type="checkbox"/> COM <input type="checkbox"/> MOT		

C13902

Parameter Name: C13902 Firmware version		Data type: VISIBLE_STRING Index: 10673 _d = 29B1 _h
Display of the firmware version (string with a length of 5 bytes) Example: "01.21"		
<input checked="" type="checkbox"/> Read access <input type="checkbox"/> Write access <input type="checkbox"/> CINH <input type="checkbox"/> PLC-STOP <input type="checkbox"/> No transfer <input type="checkbox"/> PDO_MAP_RX <input type="checkbox"/> PDO_MAP_TX <input type="checkbox"/> COM <input type="checkbox"/> MOT		

C13920

Parameter Name: C13920 Display: DIP switch setting		Data type: UNSIGNED_8 Index: 10655 _d = 299F _h
Display of the current DIP switch setting <ul style="list-style-type: none"> • The displayed value corresponds to the sum of the individual DIP switch values 1 ... 64. • The active station address is displayed under C13864. <p>▶ Possible DIP switch settings (📖 31)</p>		
Display area (min. value unit max. value)		
0		255
<input checked="" type="checkbox"/> Read access <input type="checkbox"/> Write access <input type="checkbox"/> CINH <input type="checkbox"/> PLC-STOP <input type="checkbox"/> No transfer <input type="checkbox"/> PDO_MAP_RX <input type="checkbox"/> PDO_MAP_TX <input type="checkbox"/> COM <input type="checkbox"/> MOT		

C13990

Parameter Name: C13990 ICM statistic counter		Data type: UNSIGNED_16 Index: 10585 _d = 2959 _h
Available from software version 01.21! This code is for device-internal use only and must not be overwritten by the user!		

14 Parameter reference

14.3 Parameters of the communication module for slot MXI2

14.3 Parameters of the communication module for slot MXI2

This chapter lists the parameters of the E94AYCPM communication module (PROFIBUS) for slot MXI2 of the Servo Drive 9400 in numerically ascending order.

C14231

Parameter Name: C14231 Service code	Data type: UNSIGNED_64 Index: 10344 _d = 2868 _h
This code is for device-internal use only and must not be overwritten by the user!	

C14489

Parameter Name: C14489 Service code	Data type: UNSIGNED_8 Index: 10086 _d = 2766 _h
This code is for device-internal use only and must not be overwritten by the user!	

C14531

Parameter Name: C14531 Service code	Data type: UNSIGNED_64 Index: 10044 _d = 273C _h
This code is for device-internal use only and must not be overwritten by the user!	

C14789

Parameter Name: C14789 Service code	Data type: UNSIGNED_8 Index: 9786 _d = 263A _h
This code is for device-internal use only and must not be overwritten by the user!	

C14850

Parameter Name: C14850 All words to master	Data type: UNSIGNED_16 Index: 9725 _d = 25FD _h
Display of the process data words transferred from the communication module to the PROFIBUS master. In the subcodes 1 ... 32, all process data words to the master are displayed. Only the configured process data words are valid.	
Display area (min. value unit max. value)	
0	65535
Subcodes	Info
C14850/1	
...	
C14850/32	
<input checked="" type="checkbox"/> Read access <input type="checkbox"/> Write access <input type="checkbox"/> CINH <input type="checkbox"/> PLC-STOP <input type="checkbox"/> No transfer <input type="checkbox"/> PDO_MAP_RX <input type="checkbox"/> PDO_MAP_TX <input type="checkbox"/> COM <input type="checkbox"/> MOT	

C14851

Parameter Name: C14851 All words from master		Data type: UNSIGNED_16 Index: 9724 _d = 25FC _h
Display of the process data words transferred from the PROFIBUS master to the communication module. In the subcodes 1 ... 32, all process data words to the master are displayed. Only the configured process data words are valid.		
Display area (min. value unit max. value)		
0		65535
Subcodes		Info
C14851/1		
...		
C14851/32		
<input checked="" type="checkbox"/> Read access <input type="checkbox"/> Write access <input type="checkbox"/> CINH <input type="checkbox"/> PLC-STOP <input type="checkbox"/> No transfer <input type="checkbox"/> PDO_MAP_RX <input type="checkbox"/> PDO_MAP_TX <input type="checkbox"/> COM <input type="checkbox"/> MOT		

C14852

Parameter Name: C14852 All words to standard device		Data type: UNSIGNED_16 Index: 9723 _d = 25FB _h
Display of the process data words 1 ... 32 transferred from the communication module to the standard device. In the subcodes 1 ... 32, all process data words from the communication module are displayed.		
Display area (min. value unit max. value)		
0		65535
Subcodes		Info
C14852/1		
...		
C14852/32		
<input checked="" type="checkbox"/> Read access <input type="checkbox"/> Write access <input type="checkbox"/> CINH <input type="checkbox"/> PLC-STOP <input type="checkbox"/> No transfer <input type="checkbox"/> PDO_MAP_RX <input type="checkbox"/> PDO_MAP_TX <input type="checkbox"/> COM <input type="checkbox"/> MOT		

C14853

Parameter Name: C14853 All words from standard device		Data type: UNSIGNED_16 Index: 9724 _d = 25FA _h
Display of the process data words 1 ... 32 transferred from the standard device to the communication module. In the subcodes 1 ... 32, all process data words from the standard device are displayed.		
Display area (min. value unit max. value)		
0		65535
Subcodes		Info
C14853/1		
...		
C14853/32		
<input checked="" type="checkbox"/> Read access <input type="checkbox"/> Write access <input type="checkbox"/> CINH <input type="checkbox"/> PLC-STOP <input type="checkbox"/> No transfer <input type="checkbox"/> PDO_MAP_RX <input type="checkbox"/> PDO_MAP_TX <input type="checkbox"/> COM <input type="checkbox"/> MOT		

C14854

Parameter Name: C14854 COM word to standard device		Data type: BITFIELD_32 Index: 9721 _d = 25F9 _h
Available from software version 01.21! This code is for device-internal use only and must not be overwritten by the user!		

C14855

Parameter Name: C14855 COM word from standard device	Data type: BITFIELD_32 Index: 9720 _d = 25F8 _h
Available from software version 01.21! This code is for device-internal use only and must not be overwritten by the user!	

C14860

Parameter Name: C14860 Settings	Data type: UNSIGNED_8 Index: 9715 _d = 25F3 _h
Display of the current configuration data.	
Display area (min. value unit max. value)	
0	255
Subcodes	Info
C14860/1	PROFIsafe • 0: Not active • 1: Active
C14860/2	Number of process data words (1 ... 32 words)
C14860/3	DRIVECOM parameter data channel • 0: Not active • 1: Active
C14860/4	Number of PROFIsafe words (0 or 4 words)
<input checked="" type="checkbox"/> Read access <input type="checkbox"/> Write access <input type="checkbox"/> CINH <input type="checkbox"/> PLC-STOP <input type="checkbox"/> No transfer <input type="checkbox"/> PDO_MAP_RX <input type="checkbox"/> PDO_MAP_TX <input type="checkbox"/> COM <input type="checkbox"/> MOT	

C14861

Parameter Name: C14861 Bus status	Data type: UNSIGNED_16 Index: 9714 _d = 25F2 _h
Bit-coded display of the current bus state. ▶ Querying the current bus status (□ 84)	
Display area (min. value unit max. value)	
0	65535
<input checked="" type="checkbox"/> Read access <input type="checkbox"/> Write access <input type="checkbox"/> CINH <input type="checkbox"/> PLC-STOP <input type="checkbox"/> No transfer <input type="checkbox"/> PDO_MAP_RX <input type="checkbox"/> PDO_MAP_TX <input type="checkbox"/> COM <input type="checkbox"/> MOT	

C14862

Parameter Name: C14862 Bus counter	Data type: UNSIGNED_16 Index: 9713 _d = 25F1 _h
When the maximum count value of 65535 is reached, the counter starts again with 0.	
Display area (min. value unit max. value)	
0	65535
Subcodes	Info
C14862/1	Data cycles per second
C14862/2	Total data cycles
C14862/3	Total parameterisation events
C14862/4	Total configuration events
<input checked="" type="checkbox"/> Read access <input type="checkbox"/> Write access <input type="checkbox"/> CINH <input type="checkbox"/> PLC-STOP <input type="checkbox"/> No transfer <input type="checkbox"/> PDO_MAP_RX <input type="checkbox"/> PDO_MAP_TX <input type="checkbox"/> COM <input type="checkbox"/> MOT	

C14863

Parameter Name: C14863 Baud rate		Data type: UNSIGNED_8 Index: 9712 _d = 25F0 _h
Display of the baud rate		
Selection list (read only)		
0	12.00 Mbps	
1	6.00 Mbps	
2	3.00 Mbps	
3	1.50 Mbps	
4	500.00 kbps	
5	187.50 kbps	
6	93.75 kbps	
7	45.45 kbps	
8	19.20 kbps	
9	9.60 kbps	
15	No baud rate detected	
<input checked="" type="checkbox"/> Read access <input type="checkbox"/> Write access <input type="checkbox"/> CINH <input type="checkbox"/> PLC-STOP <input type="checkbox"/> No transfer <input type="checkbox"/> PDO_MAP_RX <input type="checkbox"/> PDO_MAP_TX <input type="checkbox"/> COM <input type="checkbox"/> MOT		

C14864

Parameter Name: C14864 Active station address		Data type: UNSIGNED_8 Index: 9711 _d = 25EF _h
Display of the active station address If all DIP switches 1 ... 64 are in the "OFF" position (Lenze setting), the station address set in C14899 becomes active and is displayed here after switching on. ▶ Setting the station address (31)		
Display area (min. value unit max. value)		
0		255
<input checked="" type="checkbox"/> Read access <input type="checkbox"/> Write access <input type="checkbox"/> CINH <input type="checkbox"/> PLC-STOP <input type="checkbox"/> No transfer <input type="checkbox"/> PDO_MAP_RX <input type="checkbox"/> PDO_MAP_TX <input type="checkbox"/> COM <input type="checkbox"/> MOT		

C14865

Parameter Name: C14865 Display: Most recent PRM data		Data type: OCTET_STRING Index: 9710 _d = 25EE _h
Display of the last parameter data sent by the PROFIBUS master with the "Set-Prm" telegram (ASCII string with 24 characters)		
<input checked="" type="checkbox"/> Read access <input type="checkbox"/> Write access <input type="checkbox"/> CINH <input type="checkbox"/> PLC-STOP <input type="checkbox"/> No transfer <input type="checkbox"/> PDO_MAP_RX <input type="checkbox"/> PDO_MAP_TX <input type="checkbox"/> COM <input type="checkbox"/> MOT		

C14866

Parameter Name: C14866 Display: Most recent CFG data		Data type: OCTET_STRING Index: 9709 _d = 25ED _h
Display of the last configuration data sent by the PROFIBUS master with the "Chk-Cfg" telegram (ASCII string with 22 characters)		
<input checked="" type="checkbox"/> Read access <input type="checkbox"/> Write access <input type="checkbox"/> CINH <input type="checkbox"/> PLC-STOP <input type="checkbox"/> No transfer <input type="checkbox"/> PDO_MAP_RX <input type="checkbox"/> PDO_MAP_TX <input type="checkbox"/> COM <input type="checkbox"/> MOT		

C14867

Parameter Name: C14867 Display: Most recent diagnostic data	Data type: OCTET_STRING Index: 9708 _d = 25EC _h
Display of the last diagnostic data sent to the PROFIBUS master (ASCII string with 16 characters) ▶ Advanced diagnostic message (□ 85)	
<input checked="" type="checkbox"/> Read access <input type="checkbox"/> Write access <input type="checkbox"/> CINH <input type="checkbox"/> PLC-STOP <input type="checkbox"/> No transfer <input type="checkbox"/> PDO_MAP_RX <input type="checkbox"/> PDO_MAP_TX <input type="checkbox"/> COM <input type="checkbox"/> MOT	

C14868

Parameter Name: C14868 Display: DP state	Data type: UNSIGNED_8 Index: 9707 _d = 25EB _h
Available from software version 01.21! Display of the DP states (Decentralized Peripherals) ▶ Short-time interruption of PROFIBUS communication (□ 79), see fig. [11-1]	
Selection list (read only)	
0	Waiting for parameterisation
1	Waiting for configuration
2	Data exchange
3	n/a
<input checked="" type="checkbox"/> Read access <input type="checkbox"/> Write access <input type="checkbox"/> CINH <input type="checkbox"/> PLC-STOP <input type="checkbox"/> No transfer <input type="checkbox"/> PDO_MAP_RX <input type="checkbox"/> PDO_MAP_TX <input type="checkbox"/> COM <input type="checkbox"/> MOT	

C14880

Parameter Name: C14880 Reaction on communication fault	Data type: UNSIGNED_8 Index: 9695 _d = 25DF _h	
Monitoring response to a communication fault on the PROFIBUS A change in the monitoring response is effective immediately. ▶ Permanent interruption of PROFIBUS communication (□ 78)		
Selection list		
0	No response	
1	Error	
3	Quick stop by trouble	
4	Warning locked	
6	Information	
Subcodes	Lenze setting	Info
C14880/1	0: No response	The response set here for the "Watchdog/Data Exchange" monitoring function is executed if the bus station ... <ul style="list-style-type: none"> • does not receive a message from the master within the watchdog monitoring time (displayed in C14882/1) if there is an active connection. • detects that it is no longer in the "DATA_EXCHANGE" status. Please see also the notes given under C14881.
C14880/2	0: No response	The response set here for the "DPV1 MSAC2" monitoring is executed if the bus station does not receive a "DPV1 MSAC2" message from the master within the monitoring time (displayed in C14882/2) if there is an active connection) and the MSAC2 connection is stopped by the slave. Note: We recommend only setting "information" as response so that no drive-relevant response is executed.
<input checked="" type="checkbox"/> Read access <input checked="" type="checkbox"/> Write access <input type="checkbox"/> CINH <input type="checkbox"/> PLC-STOP <input type="checkbox"/> No transfer <input type="checkbox"/> PDO_MAP_RX <input type="checkbox"/> PDO_MAP_TX <input type="checkbox"/> COM <input type="checkbox"/> MOT		

C14881

Parameter Name: C14881 Monitoring time: Data exchange		Data type: UNSIGNED_16 Index: 9694 _d = 25DE _h
<p>If the "Data Exchange" state is exited, the response parameterised under C14880/1 is carried out when the monitoring time for data exchange set here has expired.</p> <ul style="list-style-type: none"> • A value of "65535" in this code deactivates the monitoring function. • A change in monitoring is effective immediately. • The value set here for the monitoring time must be smaller than the watchdog monitoring time (C14882/1). <p>▶ Permanent interruption of PROFIBUS communication (📖 78)</p>		
Setting range (min. value unit max. value)		Lenze setting
0	ms	65535 65535 ms
<input checked="" type="checkbox"/> Read access <input checked="" type="checkbox"/> Write access <input type="checkbox"/> CINH <input type="checkbox"/> PLC-STOP <input type="checkbox"/> No transfer <input type="checkbox"/> PDO_MAP_RX <input type="checkbox"/> PDO_MAP_TX <input type="checkbox"/> COM <input type="checkbox"/> MOT		

C14882

Parameter Name: C14882 Monitoring time: Watchdog		Data type: UNSIGNED_32 Index: 9693 _d = 25DD _h
<p>Display of the watchdog monitoring time determined by the PROFIBUS master</p> <ul style="list-style-type: none"> • A change in the watchdog monitoring time is immediately effective. • Monitoring starts with the receipt of the first telegram. • When a value of "0" is displayed, the monitoring function is deactivated. <p>▶ Permanent interruption of PROFIBUS communication (📖 78)</p>		
Display area (min. value unit max. value)		
0	ms	4294967295
Subcodes		Info
C14882/1		Watchdog monitoring time
C14882/2		DP-V1 MSC2
<input checked="" type="checkbox"/> Read access <input type="checkbox"/> Write access <input type="checkbox"/> CINH <input type="checkbox"/> PLC-STOP <input type="checkbox"/> No transfer <input type="checkbox"/> PDO_MAP_RX <input type="checkbox"/> PDO_MAP_TX <input type="checkbox"/> COM <input type="checkbox"/> MOT		

C14885

Parameter Name: C14885 Clear process data		Data type: UNSIGNED_8 Index: 9690 _d = 25DA _h
<p>Selection of the process data which the controller will process in the event of a PROFIBUS failure in order to maintain internal communication.</p>		
Selection list (Lenze setting printed in bold)		
0	Use of most recent master PDOs	
1	PDOs are set to the value '0'	
<input checked="" type="checkbox"/> Read access <input checked="" type="checkbox"/> Write access <input type="checkbox"/> CINH <input type="checkbox"/> PLC-STOP <input type="checkbox"/> No transfer <input type="checkbox"/> PDO_MAP_RX <input type="checkbox"/> PDO_MAP_TX <input type="checkbox"/> COM <input type="checkbox"/> MOT		

C14886

Parameter Name: C14886 Set ext. diagnostic bit upon		Data type: BITFIELD_8 Index: 9689 _d = 25D9 _h
Bit-coded selection of the error responses in the standard device causing the external diagnostic bit ("diag bit") to be set (see PROFIBUS specification; bit 3 of byte 1 of the DP diagnostic messages). <ul style="list-style-type: none"> • The diagnostic bit is sent to the PROFIBUS master where it is evaluated separately. • The diagnostic bit is always set when a system error occurs. • The Lenze setting "0" means that the diagnostic bit is not set for the following error responses. • An advanced diagnostic message is always sent. 		
Value is bit-coded:		
Bit 0	Error	
Bit 1	Trouble	
Bit 2	Quick stop by trouble	
Bit 3	Warning locked	
Bit 4	Warning	
Bit 5	Reserved	
Bit 6	Reserved	
Bit 7	Reserved	
<input checked="" type="checkbox"/> Read access <input checked="" type="checkbox"/> Write access <input type="checkbox"/> CINH <input type="checkbox"/> PLC-STOP <input type="checkbox"/> No transfer <input type="checkbox"/> PDO_MAP_RX <input type="checkbox"/> PDO_MAP_TX <input type="checkbox"/> COM <input type="checkbox"/> MOT		

C14887

Parameter Name: C14887 Suppress signalling diag. mess. upon		Data type: BITFIELD_8 Index: 9688 _d = 25D8 _h
Available from software version 01.20! Selection of the error responses not causing a diagnostic request to the PROFIBUS master. A diagnostic request is always signalled if a system error or an error message from the SM301 (E94AYAE) safety module occurs. The Lenze setting "0" means that for each of the following error responses a diagnostic request is signalled.		
Value is bit-coded:		Info
Bit 0	Error	
Bit 1	Trouble	
Bit 2	Quick stop by trouble	
Bit 3	Warning locked	
Bit 4	Warning	
Bit 5	Reserved	
Bit 6	Reserved	
Bit 7	Error message 0x00c88130	Available from software version 01.21! Selective suppression of the error message "Available connection to 9400 standard device lost"
<input checked="" type="checkbox"/> Read access <input checked="" type="checkbox"/> Write access <input type="checkbox"/> CINH <input type="checkbox"/> PLC-STOP <input type="checkbox"/> No transfer <input type="checkbox"/> PDO_MAP_RX <input type="checkbox"/> PDO_MAP_TX <input type="checkbox"/> COM <input type="checkbox"/> MOT		

C14897

Parameter Name: C14897 PROFIsafe: Target address		Data type: UNSIGNED_16 Index: 9678 _d = 25CE _h	
Setting of the PROFIsafe target address <ul style="list-style-type: none"> • Only required if the SM301 (E94AYAE) safety module is used. • A unique PROFIsafe target address must be assigned to each controller. 			
Einstellbereich (min. Wert Einheit max. Wert)		Lenze setting	
1		65534	1
<input checked="" type="checkbox"/> Read access <input checked="" type="checkbox"/> Write access <input type="checkbox"/> CINH <input type="checkbox"/> PLC-STOP <input type="checkbox"/> No transfer <input type="checkbox"/> PDO_MAP_RX <input type="checkbox"/> PDO_MAP_TX <input checked="" type="checkbox"/> COM <input type="checkbox"/> MOT			

C14899

Parameter Name: C14899 Station address		Data type: UNSIGNED_8 Index: 9676 _d = 25CC _h	
Optional setting of the station address (instead of setting via DIP switches 1 ... 64) <ul style="list-style-type: none"> • The station address set here only becomes effective if the DIP switches 1 ... 64 have been set to OFF prior to mains switching. • The active station address is displayed under C14864. Note: A change of the station address will not be effective until the "Save parameter set" device command has been executed and another mains switching for the communication module/controller has been performed. ▶ Setting the station address (□ 31)			
Einstellbereich (min. Wert Einheit max. Wert)		Lenze setting	
3		126	3
<input checked="" type="checkbox"/> Read access <input checked="" type="checkbox"/> Write access <input type="checkbox"/> CINH <input type="checkbox"/> PLC-STOP <input type="checkbox"/> No transfer <input type="checkbox"/> PDO_MAP_RX <input type="checkbox"/> PDO_MAP_TX <input checked="" type="checkbox"/> COM <input type="checkbox"/> MOT			

C14900

Parameter Name: C14900 Firmware product type		Data type: VISIBLE_STRING Index: 9675 _d = 25CB _h	
Display of the product type (string with a length of 8 bytes) The following identification code is displayed: "E94AFCPM".			
<input checked="" type="checkbox"/> Read access <input type="checkbox"/> Write access <input type="checkbox"/> CINH <input type="checkbox"/> PLC-STOP <input type="checkbox"/> No transfer <input type="checkbox"/> PDO_MAP_RX <input type="checkbox"/> PDO_MAP_TX <input type="checkbox"/> COM <input type="checkbox"/> MOT			

C14901

Parameter Name: C14901 Firmware compilation date		Data type: VISIBLE_STRING Index: 9674 _d = 25CA _h	
Display of the compilation date of the firmware (string with a length of 20 bytes) The date ("MMM DD YYYY") and time ("hh:mm:ss") are displayed, e.g. "Mar 21 2005 12:31:21".			
<input checked="" type="checkbox"/> Read access <input type="checkbox"/> Write access <input type="checkbox"/> CINH <input type="checkbox"/> PLC-STOP <input type="checkbox"/> No transfer <input type="checkbox"/> PDO_MAP_RX <input type="checkbox"/> PDO_MAP_TX <input type="checkbox"/> COM <input type="checkbox"/> MOT			

C14902

Parameter Name: C14902 Firmware version		Data type: VISIBLE_STRING Index: 9673 _d = 25C9 _h	
Display of the firmware version (string with a length of 5 bytes) Example: "01.21"			
<input checked="" type="checkbox"/> Read access <input type="checkbox"/> Write access <input type="checkbox"/> CINH <input type="checkbox"/> PLC-STOP <input type="checkbox"/> No transfer <input type="checkbox"/> PDO_MAP_RX <input type="checkbox"/> PDO_MAP_TX <input type="checkbox"/> COM <input type="checkbox"/> MOT			

C14920

Parameter Name: C14920 Display: DIP switch setting		Data type: UNSIGNED_8 Index: 9655 _d = 25B7 _h
Display of the current DIP switch setting <ul style="list-style-type: none"> • The displayed value corresponds to the sum of the individual DIP switch values 1 ... 64. • The active station address is displayed under C14864. • ▶ Possible DIP switch settings (📄 31) 		
Display area (min. value unit max. value)		
0		255
<input checked="" type="checkbox"/> Read access <input type="checkbox"/> Write access <input type="checkbox"/> CINH <input type="checkbox"/> PLC-STOP <input type="checkbox"/> No transfer <input type="checkbox"/> PDO_MAP_RX <input type="checkbox"/> PDO_MAP_TX <input type="checkbox"/> COM <input type="checkbox"/> MOT		

C14990

Parameter Name: C14990 ICM statistic counter		Data type: UNSIGNED_16 Index: 9585 _d = 2571 _h
Available from software version 01.21! This code is for device-internal use only and must not be overwritten by the user!		

14.4 Table of attributes

The table of attributes contains information required for communication with the controller via parameters.

How to read the table of attributes:

Column		Meaning	Entry		
Code		Parameter designation	Cxxxxx		
Name		Parameter short text (display text)	Text		
Index	dec	Index by which the parameter is addressed. The subindex for array variables corresponds to the Lenze subcode number.	24575 - Lenze code number	Is only required for access via a bus system.	
	hex		5FFF _h - Lenze code number		
Data	DS	Data structure	E	Single variable (only one parameter element)	
			A	Array variable (several parameter elements)	
	DA	Number of array elements (subcodes)	Number		
	DT	Data type	BITFIELD_8	1 byte, bit-coded	
			BITFIELD_16	2 bytes, bit-coded	
			BITFIELD_32	4 bytes, bit-coded	
			INTEGER_8	1 byte with sign	
			INTEGER_16	2 bytes with sign	
			INTEGER_32	4 bytes with sign	
			UNSIGNED_8	1 byte without sign	
			UNSIGNED_16	2 bytes without sign	
			UNSIGNED_32	4 bytes, without sign	
			VISIBLE_STRING	ASCII string	
OCTET_STRING					
Factor	Factor for data transmission via a bus system, depending on the number of decimal positions	Factor	1 = no decimal positions 10 = 1 decimal position 100 = 2 decimal positions 1000 = 3 decimal positions		
Access	R	Read access	<input checked="" type="checkbox"/> Reading permitted		
	W	Write access	<input checked="" type="checkbox"/> Writing permitted		
	CINH	Controller inhibit required	<input checked="" type="checkbox"/> Writing is only possible if controller inhibit is set		

Table of attributes

Code	Name	Index		Data				Access		
		dec	hex	DS	DA	DT	Factor	R	W	CINH
C13850	All words to master	10725	29E5	A	32	UNSIGNED_16	1	<input checked="" type="checkbox"/>		
C13851	All words from master	10724	29E4	A	32	UNSIGNED_16	1	<input checked="" type="checkbox"/>		
C13852	All words to standard device	10723	29E3	A	32	UNSIGNED_16	1	<input checked="" type="checkbox"/>		
C13853	All words from standard device	10722	29E2	A	32	UNSIGNED_16	1	<input checked="" type="checkbox"/>		
C13860	Settings	10715	29DB	A	4	UNSIGNED_8	1	<input checked="" type="checkbox"/>		
C13861	Bus status	10714	29DA	E	1	UNSIGNED_16	1	<input checked="" type="checkbox"/>		
C13862	Bus counter	10713	29D9	A	4	UNSIGNED_16	1	<input checked="" type="checkbox"/>		
C13863	Baud rate	10712	29D8	E	1	UNSIGNED_8	1	<input checked="" type="checkbox"/>		
C13864	Active station address	10711	29D7	E	1	UNSIGNED_8	1	<input checked="" type="checkbox"/>		
C13865	Display: Most recent PRM data	10710	29D6	E	1	OCTET_STRING		<input checked="" type="checkbox"/>		
C13866	Display: Most recent CFG data	10709	29D5	E	1	OCTET_STRING		<input checked="" type="checkbox"/>		
C13867	Display: Most recent diagnostic data	10708	29D4	E	1	OCTET_STRING		<input checked="" type="checkbox"/>		
C13868	Display: DP state	10707	29D3	E	1	UNSIGNED_8	1	<input checked="" type="checkbox"/>		
C13880	Reaction on communication fault	10695	29C7	A	2	UNSIGNED_8	1	<input checked="" type="checkbox"/>	<input checked="" type="checkbox"/>	
C13881	Monitoring time: Data exchange	10694	29C6	E	1	UNSIGNED_16	1	<input checked="" type="checkbox"/>	<input checked="" type="checkbox"/>	
C13882	Monitoring time: Watchdog	10693	29C5	A	2	UNSIGNED_32	1	<input checked="" type="checkbox"/>		
C13885	Clear process data	10690	29C2	E	1	UNSIGNED_8	1	<input checked="" type="checkbox"/>	<input checked="" type="checkbox"/>	
C13886	Set ext. diagnostic bit upon	10689	29C1	E	1	BITFIELD_8		<input checked="" type="checkbox"/>	<input checked="" type="checkbox"/>	
C13887	Suppress signalling diag. mess. upon	10688	29C0	E	1	BITFIELD_8		<input checked="" type="checkbox"/>	<input checked="" type="checkbox"/>	
C13897	PROFIsafe: Target address	10678	29B6	E	1	UNSIGNED_16	1	<input checked="" type="checkbox"/>	<input checked="" type="checkbox"/>	
C13899	Station address	10676	29B4	E	1	UNSIGNED_8	1	<input checked="" type="checkbox"/>	<input checked="" type="checkbox"/>	
C13900	Firmware product type	10675	29B3	E	1	VISIBLE_STRING		<input checked="" type="checkbox"/>		
C13901	Firmware compilation date	10674	29B2	E	1	VISIBLE_STRING		<input checked="" type="checkbox"/>		
C13902	Firmware version	10673	29B1	E	1	VISIBLE_STRING		<input checked="" type="checkbox"/>		
C13920	Display: DIP switch setting	10655	299F	E	1	UNSIGNED_8	1	<input checked="" type="checkbox"/>		
C14850	All words to master	9725	25FD	A	32	UNSIGNED_16	1	<input checked="" type="checkbox"/>		
C14851	All words from master	9724	25FC	A	32	UNSIGNED_16	1	<input checked="" type="checkbox"/>		
C14852	All words to standard device	9723	25FB	A	32	UNSIGNED_16	1	<input checked="" type="checkbox"/>		
C14853	All words from standard device	9722	25FA	A	32	UNSIGNED_16	1	<input checked="" type="checkbox"/>		
C14860	Settings	9715	25F3	A	4	UNSIGNED_8	1	<input checked="" type="checkbox"/>		
C14861	Bus status	9714	25F2	E	1	UNSIGNED_16	1	<input checked="" type="checkbox"/>		
C14862	Bus counter	9713	25F1	A	4	UNSIGNED_16	1	<input checked="" type="checkbox"/>		
C14863	Baud rate	9712	25F0	E	1	UNSIGNED_8	1	<input checked="" type="checkbox"/>		
C14864	Active station address	9711	25EF	E	1	UNSIGNED_8	1	<input checked="" type="checkbox"/>		
C14865	Display: Most recent PRM data	9710	25EE	E	1	OCTET_STRING		<input checked="" type="checkbox"/>		
C14866	Display: Most recent CFG data	9709	25ED	E	1	OCTET_STRING		<input checked="" type="checkbox"/>		
C14867	Display: Most recent diagnostic data	9708	25EC	E	1	OCTET_STRING		<input checked="" type="checkbox"/>		
C14868	Display: DP state	9707	25EB	E	1	UNSIGNED_8	1	<input checked="" type="checkbox"/>		
C14880	Reaction on communication fault	9695	25DF	A	2	UNSIGNED_8	1	<input checked="" type="checkbox"/>	<input checked="" type="checkbox"/>	
C14881	Monitoring time: Data exchange	9694	25DE	E	1	UNSIGNED_16	1	<input checked="" type="checkbox"/>	<input checked="" type="checkbox"/>	
C14882	Monitoring time: Watchdog	9693	25DD	A	2	UNSIGNED_32	1	<input checked="" type="checkbox"/>		
C14885	Clear process data	9690	25DA	E	1	UNSIGNED_8	1	<input checked="" type="checkbox"/>	<input checked="" type="checkbox"/>	
C14886	Set ext. diagnostic bit upon	9689	25D9	E	1	BITFIELD_8		<input checked="" type="checkbox"/>	<input checked="" type="checkbox"/>	
C14887	Suppress signalling diag. mess. upon	9688	25D8	E	1	BITFIELD_8		<input checked="" type="checkbox"/>	<input checked="" type="checkbox"/>	
C14897	PROFIsafe: Target address	9678	25CE	E	1	UNSIGNED_16	1	<input checked="" type="checkbox"/>	<input checked="" type="checkbox"/>	
C14899	Station address	9676	25CC	E	1	UNSIGNED_8	1	<input checked="" type="checkbox"/>	<input checked="" type="checkbox"/>	
C14900	Firmware product type	9675	25CB	E	1	VISIBLE_STRING		<input checked="" type="checkbox"/>		
C14901	Firmware compilation date	9674	25CA	E	1	VISIBLE_STRING		<input checked="" type="checkbox"/>		

14 Parameter reference

14.4 Table of attributes

Code	Name	Index		Data				Access		
		dec	hex	DS	DA	DT	Factor	R	W	CINH
C14902	Firmware version	9673	25C9	E	1	VISIBLE_STRING		<input checked="" type="checkbox"/>		
C14920	Display: DIP switch setting	9655	25B7	E	1	UNSIGNED_8	1	<input checked="" type="checkbox"/>		

14.5 Implemented PROFIdrive objects (DP-V1)

I-918

Index Name: 0x918 Display of station address		Data type: U16
Display of the station address set		
Display area (min. value unit max. value)		
1		126
<input checked="" type="checkbox"/> Read access <input type="checkbox"/> Write access		

I-963

Index Name: 0x963 Baud rate		Data type: U16
Display of the PROFIBUS baud rate		
Selection list (read only)		
0	9.6 kbps	
1	19.2 kbps	
2	93.75 kbps	
3	187.5 kbps	
4	500 kbps	
6	1.5 Mbps	
7	3 Mbps	
8	6 Mbps	
9	12 Mbps	
10	31.25 kbps	
11	45.45 kbps	
<input checked="" type="checkbox"/> Read access <input type="checkbox"/> Write access		

I-964

Index Name: 0x964 Device identification		Data type: U16
Display of identification data		
Subindex	Display	Info
0x964/0	262	Manufacturer: Lenze
0x964/1	9400	Device type
0x964/2	xxyy	Software version, e.g. 0111 (V 1.20)
0x964/3	yyyy	Firmware date (year), e.g. 2006
0x964/4	ddmm	Firmware date (day/month), e.g. 0506 (5th June)
<input checked="" type="checkbox"/> Read access <input type="checkbox"/> Write access		

I-974

Index Name:		Data type: U16
0x974 Maximum time per DPV1 parameter access		
Display of access statistics		
Subindex	Display	Info
0x974/0	240 bytes	Maximum block length
0x974/1	40	Maximum number of parameter accesses
0x974/2	0	Maximum time per access
<input checked="" type="checkbox"/> Read access <input type="checkbox"/> Write access		

15 DIP switch positions for setting the station address

The station address results from the sum of the binary valencies of switches 1 ... 64.

The following table shows the switch positions for the valid address range 1 ... 126.

▶ [Setting the station address \(□ 31\)](#)

Station address	DIP switch						
	64	32	16	8	4	2	1
1	OFF	OFF	OFF	OFF	OFF	OFF	ON
2	OFF	OFF	OFF	OFF	OFF	ON	OFF
3	OFF	OFF	OFF	OFF	OFF	ON	ON
4	OFF	OFF	OFF	OFF	ON	OFF	OFF
5	OFF	OFF	OFF	OFF	ON	OFF	ON
6	OFF	OFF	OFF	OFF	ON	ON	OFF
7	OFF	OFF	OFF	OFF	ON	ON	ON
8	OFF	OFF	OFF	ON	OFF	OFF	OFF
9	OFF	OFF	OFF	ON	OFF	OFF	ON
10	OFF	OFF	OFF	ON	OFF	ON	OFF
11	OFF	OFF	OFF	ON	OFF	ON	ON
12	OFF	OFF	OFF	ON	ON	OFF	OFF
13	OFF	OFF	OFF	ON	ON	OFF	ON
14	OFF	OFF	OFF	ON	ON	ON	OFF
15	OFF	OFF	OFF	ON	ON	ON	ON
16	OFF	OFF	ON	OFF	OFF	OFF	OFF
17	OFF	OFF	ON	OFF	OFF	OFF	ON
18	OFF	OFF	ON	OFF	OFF	ON	OFF
19	OFF	OFF	ON	OFF	OFF	ON	ON
20	OFF	OFF	ON	OFF	ON	OFF	OFF
21	OFF	OFF	ON	OFF	ON	OFF	ON
22	OFF	OFF	ON	OFF	ON	ON	OFF
23	OFF	OFF	ON	OFF	ON	ON	ON
24	OFF	OFF	ON	ON	OFF	OFF	OFF
25	OFF	OFF	ON	ON	OFF	OFF	ON
26	OFF	OFF	ON	ON	OFF	ON	OFF
27	OFF	OFF	ON	ON	OFF	ON	ON
28	OFF	OFF	ON	ON	ON	OFF	OFF
29	OFF	OFF	ON	ON	ON	OFF	ON
30	OFF	OFF	ON	ON	ON	ON	OFF
31	OFF	OFF	ON	ON	ON	ON	ON
32	OFF	ON	OFF	OFF	OFF	OFF	OFF
33	OFF	ON	OFF	OFF	OFF	OFF	ON
34	OFF	ON	OFF	OFF	OFF	ON	OFF
35	OFF	ON	OFF	OFF	OFF	ON	ON
36	OFF	ON	OFF	OFF	ON	OFF	OFF
37	OFF	ON	OFF	OFF	ON	OFF	ON

Station address	DIP switch						
	64	32	16	8	4	2	1
38	OFF	ON	OFF	OFF	ON	ON	OFF
39	OFF	ON	OFF	OFF	ON	ON	ON
40	OFF	ON	OFF	ON	OFF	OFF	OFF
41	OFF	ON	OFF	ON	OFF	OFF	ON
42	OFF	ON	OFF	ON	OFF	ON	OFF
43	OFF	ON	OFF	ON	OFF	ON	ON
44	OFF	ON	OFF	ON	ON	OFF	OFF
45	OFF	ON	OFF	ON	ON	OFF	ON
46	OFF	ON	OFF	ON	ON	ON	OFF
47	OFF	ON	OFF	ON	ON	ON	ON
48	OFF	ON	ON	OFF	OFF	OFF	OFF
49	OFF	ON	ON	OFF	OFF	OFF	ON
50	OFF	ON	ON	OFF	OFF	ON	OFF
51	OFF	ON	ON	OFF	OFF	ON	ON
52	OFF	ON	ON	OFF	ON	OFF	OFF
53	OFF	ON	ON	OFF	ON	OFF	ON
54	OFF	ON	ON	OFF	ON	ON	OFF
55	OFF	ON	ON	OFF	ON	ON	ON
56	OFF	ON	ON	ON	OFF	OFF	OFF
57	OFF	ON	ON	ON	OFF	OFF	ON
58	OFF	ON	ON	ON	OFF	ON	OFF
59	OFF	ON	ON	ON	OFF	ON	ON
60	OFF	ON	ON	ON	ON	OFF	OFF
61	OFF	ON	ON	ON	ON	OFF	ON
62	OFF	ON	ON	ON	ON	ON	OFF
63	OFF	ON	ON	ON	ON	ON	ON
64	ON	OFF	OFF	OFF	OFF	OFF	OFF
65	ON	OFF	OFF	OFF	OFF	OFF	ON
66	ON	OFF	OFF	OFF	OFF	ON	OFF
67	ON	OFF	OFF	OFF	OFF	ON	ON
68	ON	OFF	OFF	OFF	ON	OFF	OFF
69	ON	OFF	OFF	OFF	ON	OFF	ON
70	ON	OFF	OFF	OFF	ON	ON	OFF
71	ON	OFF	OFF	OFF	ON	ON	ON
72	ON	OFF	OFF	ON	OFF	OFF	OFF
73	ON	OFF	OFF	ON	OFF	OFF	ON
74	ON	OFF	OFF	ON	OFF	ON	OFF
75	ON	OFF	OFF	ON	OFF	ON	ON
76	ON	OFF	OFF	ON	ON	OFF	OFF
77	ON	OFF	OFF	ON	ON	OFF	ON
78	ON	OFF	OFF	ON	ON	ON	OFF
79	ON	OFF	OFF	ON	ON	ON	ON
80	ON	OFF	ON	OFF	OFF	OFF	OFF

Station address	DIP switch						
	64	32	16	8	4	2	1
81	ON	OFF	ON	OFF	OFF	OFF	ON
82	ON	OFF	ON	OFF	OFF	ON	OFF
83	ON	OFF	ON	OFF	OFF	ON	ON
84	ON	OFF	ON	OFF	ON	OFF	OFF
85	ON	OFF	ON	OFF	ON	OFF	ON
86	ON	OFF	ON	OFF	ON	ON	OFF
87	ON	OFF	ON	OFF	ON	ON	ON
88	ON	OFF	ON	ON	OFF	OFF	OFF
89	ON	OFF	ON	ON	OFF	OFF	ON
90	ON	OFF	ON	ON	OFF	ON	OFF
91	ON	OFF	ON	ON	OFF	ON	ON
92	ON	OFF	ON	ON	ON	OFF	OFF
93	ON	OFF	ON	ON	ON	OFF	ON
94	ON	OFF	ON	ON	ON	ON	OFF
95	ON	OFF	ON	ON	ON	ON	ON
96	ON	ON	OFF	OFF	OFF	OFF	OFF
97	ON	ON	OFF	OFF	OFF	OFF	ON
98	ON	ON	OFF	OFF	OFF	ON	OFF
99	ON	ON	OFF	OFF	OFF	ON	ON
100	ON	ON	OFF	OFF	ON	OFF	OFF
101	ON	ON	OFF	OFF	ON	OFF	ON
102	ON	ON	OFF	OFF	ON	ON	OFF
103	ON	ON	OFF	OFF	ON	ON	ON
104	ON	ON	OFF	ON	OFF	OFF	OFF
105	ON	ON	OFF	ON	OFF	OFF	ON
106	ON	ON	OFF	ON	OFF	ON	OFF
107	ON	ON	OFF	ON	OFF	ON	ON
108	ON	ON	OFF	ON	ON	OFF	OFF
109	ON	ON	OFF	ON	ON	OFF	ON
110	ON	ON	OFF	ON	ON	ON	OFF
111	ON	ON	OFF	ON	ON	ON	ON
112	ON	ON	ON	OFF	OFF	OFF	OFF
113	ON	ON	ON	OFF	OFF	OFF	ON
114	ON	ON	ON	OFF	OFF	ON	OFF
115	ON	ON	ON	OFF	OFF	ON	ON
116	ON	ON	ON	OFF	ON	OFF	OFF
117	ON	ON	ON	OFF	ON	OFF	ON
118	ON	ON	ON	OFF	ON	ON	OFF
119	ON	ON	ON	OFF	ON	ON	ON
120	ON	ON	ON	ON	OFF	OFF	OFF
121	ON	ON	ON	ON	OFF	OFF	ON
122	ON	ON	ON	ON	OFF	ON	OFF
123	ON	ON	ON	ON	OFF	ON	ON

15 DIP switch positions for setting the station address

Station address	DIP switch						
	64	32	16	8	4	2	1
124	ON	ON	ON	ON	ON	OFF	OFF
125	ON	ON	ON	ON	ON	OFF	ON
126	ON	ON	ON	ON	ON	ON	OFF

Index

0 - 9

- 0x918 | Display of station address [114](#)
- 0x963 | Baud rate [114](#)
- 0x964 | Device identification [114](#)
- 0x974 | Maximum time per DPV1 parameter access [115](#)

A

- Abort of data transfer by the controller (DP-V0) [51](#)
- Activating the bus terminating resistor [25](#)
- Active station address (C13864) [96](#)
- Active station address (C14864) [105](#)
- Acyclic data transfer (DP-V1) [59](#)
- Addressing of Lenze parameters/parameter data [47](#)
- All words from master (C13851) [94](#)
- All words from master (C14851) [103](#)
- All words from standard device (C13853) [94](#)
- All words from standard device (C14853) [103](#)
- All words to master (C13850) [93](#)
- All words to master (C14850) [102](#)
- All words to standard device (C13852) [94](#)
- All words to standard device (C14852) [103](#)
- Application as directed [12](#)
- Application notes [9](#)
- Application of the communication module [12](#)
- Approvals [15](#)

B

- Baud [114](#)
- Baud rate [15](#)
- Baud rate (0x963) [114](#)
- Baud rate (C13863) [96](#)
- Baud rate (C14863) [105](#)
- Bus cable length [26](#)
- Bus counter (C13862) [95](#)
- Bus counter (C14862) [104](#)
- Bus device type [15](#)
- Bus status (C13861) [95](#)
- Bus status (C14861) [104](#)

C

- C00615 | Resp. to imp. device conf. [91](#)
- C00636 | Resp. to new module in MXI1 [91](#)
- C00637 | Resp. to new module in MXI2 [92](#)
- C01501 | Resp. to comm. error with MXI1 [92](#)
- C01502 | Resp. to comm. error with MXI2 [92](#)
- C13231 | Service code [93](#)
- C13489 | Service code [93](#)
- C13531 | Service code [93](#)
- C13789 | Service code [93](#)
- C13850 | All words to master [93](#)
- C13851 | All words from master [94](#)
- C13852 | All words to standard device [94](#)
- C13853 | All words from standard device [94](#)

- C13854 | COM word to standard device [94](#)
- C13855 | COM word from standard device [95](#)
- C13860 | Settings [95](#)
- C13861 | Bus status [95](#)
- C13862 | Bus counter [95](#)
- C13863 | Baud rate [96](#)
- C13864 | Active station address [96](#)
- C13865 | Display: Most recent PRM data [96](#)
- C13866 | Display: Most recent CFG data [96](#)
- C13867 | Display: Most recent diagnostic data [97](#)
- C13868 | Display: DP state [97](#)
- C13880 | Reaction on communication fault [97](#)
- C13881 | Monitoring time: Data exchange [98](#)
- C13882 | Monitoring time: Watchdog [98](#)
- C13885 | Clear process data [98](#)
- C13886 | Set ext. diagnostic bit upon [99](#)
- C13887 | Suppress signalling diag. mess. upon [99](#)
- C13897 | PROFIsafe: Target address [100](#)
- C13899 | Station address [100](#)
- C13900 | Firmware product type [100](#)
- C13901 | Firmware compilation date [100](#)
- C13902 | Firmware version [100](#)
- C13920 | Display: DIP switch setting [101](#)
- C13990 | ICM statistic counter [101](#)
- C14231 | Service code [102](#)
- C14489 | Service code [102](#)
- C14531 | Service code [102](#)
- C14789 | Service code [102](#)
- C14850 | All words to master [102](#)
- C14851 | All words from master [103](#)
- C14852 | All words to standard device [103](#)
- C14853 | All words from standard device [103](#)
- C14854 | COM word to standard device [103](#)
- C14855 | COM word from standard device [104](#)
- C14860 | Settings [104](#)
- C14861 | Bus status [104](#)
- C14862 | Bus counter [104](#)
- C14863 | Baud rate [105](#)
- C14864 | Active station address [105](#)
- C14865 | Display: Most recent PRM data [105](#)
- C14866 | Display: Most recent CFG data [105](#)
- C14867 | Display: Most recent diagnostic data [106](#)
- C14868 | Display: DP state [106](#)
- C14880 | Reaction on communication fault [106](#)
- C14881 | Monitoring time: Data exchange [107](#)
- C14882 | Monitoring time: Watchdog [107](#)
- C14885 | Clear process data [107](#)
- C14886 | Set ext. diagnostic bit upon [108](#)
- C14887 | Suppress signalling diag. mess. upon [108](#)
- C14897 | PROFIsafe: Target address [109](#)
- C14899 | Station address [109](#)
- C14900 | Firmware product type [109](#)
- C14901 | Firmware compilation date [109](#)

C14902 | Firmware version [109](#)
C14920 | Display: DIP switch setting [110](#)
C14990 | ICM statistic counter [110](#)
Cable length [15](#)
Clear process data (C13885) [98](#)
Clear process data (C14885) [107](#)
Codes [91](#)
COM word from standard device (C13855) [95](#)
COM word from standard device (C14855) [104](#)
COM word to standard device (C13854) [94](#)
COM word to standard device (C14854) [103](#)
Commissioning [29](#)
Communication channels [43](#)
Communication medium [15](#)
Communication profile [15](#)
Communication time [19](#)
Communication-relevant parameters of the standard device [91](#)
Configuration of the host (master) [30](#)
Configuration of the master [30](#)
Configuration of the PROFIBUS master [30](#)
Conformities [15](#)
Connection establishment between master and slave (DP-V1) [58](#)
Consistent parameter data [76](#)

D

Data transfer [43](#)
Data transfer abort by the master (DP-V0) [51](#)
Defining the user data length [30](#)
Device [114](#)
Device- and application-specific safety instructions [11](#)
Device data base file [30](#)
Device description file [30](#)
Device identification (0x964) [114](#)
Device protection [11](#)
Diagnostic message [85](#)
Diagnostics [82](#), [83](#)
Diagnostics with the »Engineer« [83](#)
Dimensions [20](#)
DIP switch positions for setting the station address [116](#)
DIP switch settings [31](#)
Dismounting [22](#)
Display [114](#)
 DIP switch setting (C13920) [101](#)
 DIP switch setting (C14920) [110](#)
 DP state (C13868) [97](#)
 DP state (C14868) [106](#)
 Most recent CFG data (C13866) [96](#)
 Most recent CFG data (C14866) [105](#)
 Most recent diagnostic data (C13867) [97](#)
 Most recent diagnostic data (C14867) [106](#)
 Most recent PRM data (C13865) [96](#)
 Most recent PRM data (C14865) [105](#)

Display of station address (0x918) [114](#)
DP states for short-time interruption of communication [79](#)
DP-V0 [48](#)
DP-V1 [57](#)
DRIVECOM [48](#)
DRIVECOM parameter data channel (DP-V0) [48](#)

E

Electrical installation [23](#)
E-mail to Lenze [124](#)
EMF2133IB compatibility [32](#)
Error codes (DP-V0) [54](#)
Error codes (DP-V1) [70](#)
Error messages [87](#)
 Causes and remedies [88](#)
 Short overview [87](#)
Error number
 0x00c83100 [88](#)
 0x00c85531 [88](#)
 0x00c85532 [88](#)
 0x00c85533 [88](#)
 0x00c86010 [88](#)
 0x00c86011 [89](#)
 0x00c86100 [89](#)
 0x00c86101 [89](#)
 0x00c86110 [89](#)
 0x00c8641f [89](#)
 0x00c86420 [89](#)
 0x00c88130 [90](#)
 0x00c88131 [90](#)
 0x00c88132 [90](#)

F

Features [13](#)
Feedback to Lenze [124](#)
Firmware compilation date (C13901) [100](#)
Firmware compilation date (C14901) [109](#)
Firmware product type (C13900) [100](#)
Firmware product type (C14900) [109](#)
Firmware version (C13902) [100](#)
Firmware version (C14902) [109](#)

G

General data [15](#)
General safety and application instructions [10](#)
Going online with »Engineer« via TCI [34](#)

I

- ICM statistic counter (C13990) [101](#)
- ICM statistic counter (C14990) [110](#)
- Identification [12](#)
- Installation [21](#)
- Interface [15](#)
- Interfaces [14](#)
- Interruption [81](#)
- Interruption of internal communication [81](#)

L

- Layout of the safety instructions [9](#)
- LED status displays [82](#)

M

- Maximum [115](#)
- Maximum time per DPV1 parameter access (0x974) [115](#)
- Mechanical installation [22](#)
- Monitoring [78, 80](#)
 - Permanent interruption of PROFIBUS communication [78](#)
 - Settings and displays in the »Engineer« [80](#)
 - Short-time interruption of PROFIBUS communication [79](#)
- Monitoring time
 - Data exchange (C13881) [98](#)
 - Data exchange (C14881) [107](#)
 - Watchdog (C13882) [98](#)
 - Watchdog (C14882) [107](#)
- Mounting [22](#)

N

- Nameplate [12](#)
- Network topology [15, 23](#)
- Number of stations [15, 24](#)

O

- Operating conditions [15](#)

P

- Parameter addressing [47](#)
- Parameter data transfer [47](#)
- Parameter reference [91](#)
- Parameters of the communication module for slot MX11 [93](#)
- Parameters of the communication module for slot MX12 [102](#)
- PDO mapping [44](#)
- PNO identification number [15](#)
- Process data objects [44](#)
- Process data transfer [44](#)
- Processing time [19](#)
- Product description [12](#)

Profibus

- Data_Exchange state exited (error message) [90](#)
- Error: Lenze setting loaded (error message) [89](#)
- Internal error (error message) [89](#)
- Internal mapping error (error message) [89](#)
- Invalid parameter record (error message) [89](#)
- Lost connection to 9400 base device (error message) [88](#)
- Memory
 - No access (error message) [88](#)
 - Read error (error message) [88](#)
 - Write error (error message) [88](#)
 - Restart after watchdog reset (error message) [88](#)
- PROFIBUS connection [27](#)
- PROFIBUS error messages
 - Causes and remedies [88](#)
 - Short overview [87](#)
- Profibus watchdog
 - DP-V1 MSAC2 elapsed (error message) [90](#)
 - Monitoring time elapsed (error message) [90](#)
- PROFdrive [57](#)
- PROFdrive objects (DP-V1) [114](#)
- PROFdrive parameter data channel (DP-V1) [57](#)
- PROFIsafe [77](#)
 - Target address (C13897) [100](#)
 - Target address (C14897) [109](#)
- Protection against uncontrolled restart [33](#)
- Protection of persons [11](#)
- Protective insulation [16](#)
- Protocol data [19](#)

Q

- Querying the bus status [84](#)
- Querying the current bus status [84](#)

R

- Reaction on communication fault (C13880) [97](#)
- Reaction on communication fault (C14880) [106](#)
- Reading parameter data from the controller (DP-V0) [50](#)
- Reading parameter data from the controller (DP-V1) [61](#)
- Residual hazards [11](#)
- Resp. to comm. error with MX11 (C01501) [92](#)
- Resp. to comm. error with MX12 (C01502) [92](#)
- Resp. to imp. device conf. (C00615) [91](#)
- Resp. to new module in MX11 (C00636) [91](#)
- Resp. to new module in MX12 (C00637) [92](#)

Index

S

Safety instructions [9](#), [10](#)
Screenshots/application examples [6](#)
Service code (C13231) [93](#)
Service code (C13489) [93](#)
Service code (C13531) [93](#)
Service code (C13789) [93](#)
Service code (C14231) [102](#)
Service code (C14489) [102](#)
Service code (C14531) [102](#)
Service code (C14789) [102](#)
Set ext. diagnostic bit upon (C13886) [99](#)
Set ext. diagnostic bit upon (C14886) [108](#)
Setting the station address [31](#)
Settings [32](#)
Settings (C13860) [95](#)
Settings (C14860) [104](#)
Short-time interruption of PROFIBUS communication [79](#)
Station address (C13899) [100](#)
Station address (C14899) [109](#)
Status displays [82](#)
Structure of the safety instructions [9](#)
Suppress signalling diag. mess. upon (C13887) [99](#)
Suppress signalling diag. mess. upon (C14887) [108](#)
System error messages [87](#)

T

Table of attributes [111](#)
Target group [6](#)
TCI (Tool Calling Interfaces) [34](#)
Technical data [15](#)
Telegram examples (DP-V0) [55](#)
Telegram examples (DP-V1) [72](#)
Telegram structure (DP-V0) [48](#)
Telegram structure (DP-V1) [60](#)
Terminals [14](#)
Terminology used [8](#)

U

Use of repeaters [23](#)

V

Validity information [6](#)
Voltage supply [15](#), [28](#)

W

Writing parameter data to the controller (DP-V0) [50](#)
Writing parameter data to the controller (DP-V1) [66](#)

FEEDBACK



Your opinion is important to us

These instructions were created to the best of our knowledge and belief to give you the best possible support for handling our product.

If you have suggestions for improvement, please e-mail us to:

feedback-docu@Lenze.de

Thank you for your support.

Your Lenze documentation team



Lenze Automation GmbH
Hans-Lenze-Str. 1
D-31855 Aerzen
Germany
☎ +49 (0)51 54 / 82-0
📠 +49 (0)51 54 / 82-28 00
✉ Lenze@Lenze.de
🌐 www.Lenze.com

Service

Lenze Service GmbH
Breslauer Straße 3
D-32699 Extertal
Germany
☎ 00 80 00 / 24 4 68 77 (24 h helpline)
📠 +49 (0)51 54 / 82-11 12
✉ Service@Lenze.de