



Main

| | |
|---------------------------|---|
| Range of product | Lexium 32 |
| Product or component type | Motion servo drive |
| Device short name | LXM32A |
| Format of the drive | Book |
| Network number of phases | Three phase |
| [Us] rated supply voltage | 200...240 V - 15...10 % 380...480 V - 15...10 % |
| Supply voltage limits | 170...264 V 323...528 V |
| Supply frequency | 50/60 Hz - 5...5 % |
| Network frequency | 47.5...63 Hz |
| EMC filter | Integrated |
| Continuous output current | 10 A at 8 kHz |
| Output current 3s peak | 30 A for 5 s |
| Maximum continuous power | 2600 W at 230 V 5600 W at 400 V |
| Nominal power | 2 kW at 230 V 8 kHz 3 kW at 400 V 8 kHz |
| Line current | 11.6 A 74 % at 380 V, with external line choke of 1 mH 9.6 A 85 % at 480 V, with external line choke of 1 mH 7 A 152 % at 480 V, without line choke 9.8 A 146 % at 380 V, without line choke |

Complementary

| | |
|-------------------------|-------------------------|
| Switching frequency | 8 kHz |
| Overvoltage category | III |
| Maximum leakage current | 30 mA |
| Output voltage | <= power supply voltage |

| | |
|-------------------------|---|
| Electrical isolation | Between power and control |
| Type of cable | Single-strand IEC cable (temperature: 50 °C) copper 90 °C XLPE/EPR |
| Electrical connection | Terminal, clamping capacity: 3 mm ² , AWG 12 (CN8) Terminal, clamping capacity: 5 mm ² , AWG 10 (CN1) Terminal, clamping capacity: 5 mm ² , AWG 10 (CN10) |
| Tightening torque | CN8: 0.5 N.m CN1: 0.7 N.m CN10: 0.7 N.m |
| Discrete input number | 1 capture discrete input(s) 2 safety discrete input(s) 4 logic discrete input(s) |
| Discrete input type | Capture (CAP terminals) Logic (DI terminals) Safety (compliment of STO_A, compliment of STO_B terminals) |
| Sampling duration | DI: 0.25 ms discrete |
| Discrete input voltage | 24 V DC for capture 24 V DC for logic 24 V DC for safety |
| Discrete input logic | Positive (compliment of STO_A, compliment of STO_B) at State 0: < 5 V at State 1: > 15 V conforming to EN/IEC 61131-2 type 1 Positive (DI) at State 0: > 19 V at State 1: < 9 V conforming to EN/IEC 61131-2 type 1 Positive or negative (DI) at State 0: < 5 V at State 1: > 15 V conforming to EN/IEC 61131-2 type 1 |
| Response time | <= 5 ms compliment of STO_A, compliment of STO_B |
| Discrete output number | 2 |
| Discrete output type | Logic output(s) (DO) 24 V DC |
| Discrete output voltage | <= 30 V DC |
| Discrete output logic | Positive or negative (DO) conforming to EN/IEC 61131-2 |
| Contact bounce time | <= 1 ms for compliment of STO_A, compliment of STO_B 2 µs for CAP 0.25 µs...1.5 ms for DI |
| Braking current | 50 mA |
| Response time on output | 250 µs (DO) for discrete output(s) |
| Control signal type | Servo motor encoder feedback |
| Protection type | Against reverse polarity: inputs signal Against short-circuits: outputs signal |
| Safety function | STO (safe torque off), integrated |
| Safety level | SIL 3 conforming to EN/IEC 61508 PL = e conforming to ISO 13849-1 |
| Communication interface | CANmotion, integrated CANopen, integrated Modbus, integrated |
| Connector type | RJ45 (labelled CN4 or CN5) for CANmotion RJ45 (labelled CN4 or CN5) for CANopen RJ45 (labelled CN7) for Modbus |
| Method of access | Slave |
| Commissioning port | 2-wire RS485 multidrop for Modbus |
| Transmission rate | 1 Mbps for bus length of 4 m for CANopen, CANmotion 125 kbps for bus length of 500 m for CANopen, CANmotion 250 kbps for bus length of 250 m for CANopen, CANmotion 50 kbps for bus length of 1000 m for CANopen, CANmotion 500 kbps for bus length of 100 m for CANopen, CANmotion 9600, 19200, 38400 bps for bus length of 40 m for Modbus |
| Number of addresses | 1...127 for CANopen, CANmotion 1...247 for Modbus |
| Communication service | 1 receive SDO for CANmotion 1 transmit SDO for CANmotion 2 PDOs conforming to DSP 402 for CANmotion 2 SDOs receive for CANopen 2 SDOs send for CANopen 4 configurable mapping PDOs for CANopen CANopen device profile drives and motion control for CANopen, CANmotion Display of faults on integrated display terminal for Modbus Emergency for CANopen, CANmotion Event-triggered, time-triggered, remotely requested, sync (cyclic), sync (acyclic) for CANopen |

Node guarding, heartbeat for CANopen
 Position control mode for CANmotion
 Position control, speed profile, torque profile and homing mode for CANopen
 Sync for CANmotion

| | |
|-----------------------|--|
| Status LED | 1 LED (red)servo drive voltage 1 LEDerror 1 LEDRUN |
| Signalling function | Display of faults 7 segments |
| Marking | CE |
| Operating position | Vertical +/- 10 degree |
| Product compatibility | Servo motor BMH (100 mm, 3 motor stacks) Servo motor BMH (140 mm, 1 motor stacks) Servo motor BSH (100 mm, 3 motor stacks) Servo motor BSH (100 mm, 4 motor stacks) Servo motor BSH (140 mm, 1 motor stacks) |
| Width | 68 mm |
| Height | 270 mm |
| Depth | 237 mm |
| Net weight | 2.6 kg |

Environment

| | |
|---------------------------------------|---|
| Electromagnetic compatibility | Conducted EMC, class A group 1 conforming to EN 55011 Conducted EMC, class A group 2 conforming to EN 55011 Conducted EMC, environment 2 category C3 conforming to EN/IEC 61800-3 Conducted EMC, category C2 conforming to EN/IEC 61800-3 Conducted EMC, environments 1 and 2 conforming to EN/IEC 61800-3 Electrostatic discharge immunity test, level 3 conforming to EN/IEC 61000-4-2 Susceptibility to electromagnetic fields, level 3 conforming to EN/IEC 61000-4-3 1.2/50 µs shock waves immunity test, level 3 conforming to EN/IEC 61000-4-5 Electrical fast transient/burst immunity test, level 4 conforming to EN/IEC 61000-4-4 Radiated EMC, class A group 2 conforming to EN 55011 Radiated EMC, category C3 conforming to EN/IEC 61800-3 |
| Standards | EN/IEC 61800-3 EN/IEC 61800-5-1 |
| Product certifications | UL CSA TÜV |
| IP degree of protection | IP20 conforming to EN/IEC 60529 IP20 conforming to EN/IEC 61800-5-1 |
| Vibration resistance | 1 gn (f= 13...150 Hz) conforming to EN/IEC 60068-2-6 1.5 mm peak to peak (f= 3...13 Hz) conforming to EN/IEC 60068-2-6 |
| Shock resistance | 15 gn for 11 ms conforming to EN/IEC 60028-2-27 |
| Pollution degree | 2 conforming to EN/IEC 61800-5-1 |
| Environmental characteristic | Classes 3C1 conforming to IEC 60721-3-3 |
| Relative humidity | Class 3K3 (5 to 85 %) without condensation conforming to IEC 60721-3-3 |
| Ambient air temperature for operation | 0...50 °C conforming to UL |
| Ambient air temperature for storage | -25...70 °C |
| Type of cooling | Integrated fan |
| Operating altitude | <= 1000 m without derating > 1000...3000 m with conditions |

Packing Units

| | |
|------------------|----------|
| Package 1 Weight | 3.220 kg |
| Package 1 Height | 1.050 dm |
| Package 1 width | 2.760 dm |
| Package 1 Length | 3.300 dm |

Offer Sustainability

| | |
|--------------------------|-----------------------|
| Sustainable offer status | Green Premium product |
|--------------------------|-----------------------|

| | |
|----------------------------|---|
| REACH Regulation | REACH Declaration |
| EU RoHS Directive | Pro-active compliance (Product out of EU RoHS legal scope) EU RoHS Declaration |
| Mercury free | Yes |
| RoHS exemption information | Yes |
| China RoHS Regulation | China RoHS declaration |
| Environmental Disclosure | Product Environmental Profile |
| Circularity Profile | End of Life Information |
| WEEE | The product must be disposed on European Union markets following specific waste collection and never end up in rubbish bins |
| PVC free | Yes |

Contractual warranty

| | |
|----------|-----------|
| Warranty | 18 months |
|----------|-----------|

Lexium 32 Servo Drive

Dimensions

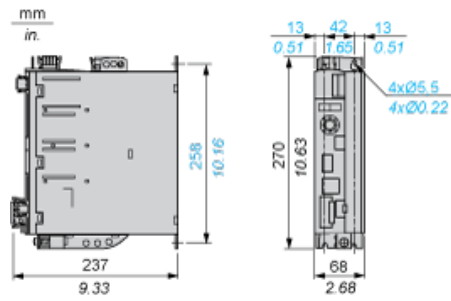

Lexium 32 Motion Control Servo Drives

Mounting Recommendations

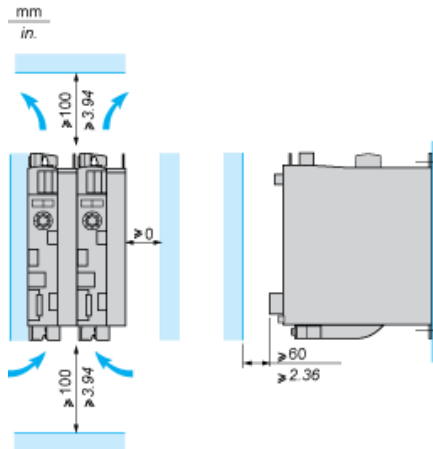

LXM32•U45M2, •U90M2 and LXM32•U60N4 servo drives are cooled by natural convection. LXM32•D18M2, •D30M2, LXM32 •D12N4, •D18N4, •D30N4 and •D72N4 servo drives have an integrated fan.

When installing the servo drive in the enclosure, follow the instructions below with regard to the temperature and protection index:

- Provide sufficient cooling of the servo drive
- Do not mount the servo drive near heat sources
- Do not mount the servo drive on flammable materials
- Do not heat the servo drive cooling air by currents of hot air from other equipment and components, for example from an external braking resistor
- Mount the servo drive vertically ($\pm 10\%$)
- If the servo drive is used above its thermal limits, control stops due to overtemperature

NOTE: For cables that are connected via the underside of the servo drive, a free space ≥ 200 mm/7.87 in. is required under the unit to comply with the bending radius of the connection cables.

| Ambient temperature | Mounting distances | Instructions to be followed |
|---------------------|--------------------|---|
| 0°C...+ 50°C | $d \geq 0$ mm | – |
| + 50°C...+ 60°C | $d \geq 0$ mm | Reduce the output current by 2.2% per °C above 50°C |

NOTE: Do not use insulated enclosures, as they have a poor level of conductivity.

Recommendations for Mounting in an Enclosure

To ensure good air circulation in the servo drive:

- Fit ventilation grilles on the enclosure.
- Ensure that ventilation is adequate, otherwise install a forced ventilation unit with a filter.

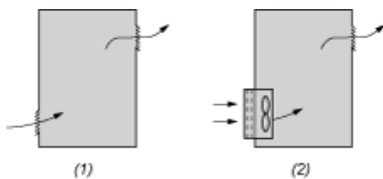

- (1) Natural convection
(2) Forced ventilation

- Any apertures and/or fans must provide a flow rate at least equal to that of the servo drive fans (refer to characteristics).
- Use special filters with IP 54 protection.

Mounting in Metal Enclosure (IP 54 Degree of Protection)

The servo drive must be mounted in a dust and damp proof enclosure in certain environmental conditions, such as dust, corrosive gases, high humidity with risk of condensation and dripping water, splashing liquid, etc. In these cases, Lexium 32 servo drives can be installed in an enclosure where the internal temperature must not exceed 60°C.