



Main

| | |
|------------------------------|--|
| Range of product | Altivar Machine ATV340 |
| Product or component type | Variable speed drive |
| Product specific application | Machine |
| Variant | Standard version |
| Mounting mode | Cabinet mount |
| Communication port protocol | Modbus serial |
| Option card | Communication module, Profibus DP V1 Communication module, Profinet Communication module, DeviceNet Communication module, CANopen Communication module, EtherCAT |
| Network number of phases | 3 phases |
| Supply frequency | 50...60 Hz +/- 5 % |
| [Us] rated supply voltage | 380...480 V - 15...10 % |
| Nominal output current | 2.2 A |
| Motor power kW | 1.1 kW for normal duty 0.75 kW for heavy duty |
| Motor power hp | 1.5 hp for normal duty 1 hp for heavy duty |
| EMC filter | Class C3 EMC filter integrated |
| IP degree of protection | IP20 |

Complementary

| | |
|-------------------------|---|
| Discrete input number | 5 |
| Discrete input type | PTI programmable as pulse input: 0...30 kHz, 24 V DC (30 V) DI1...DI5 safe torque off, 24 V DC (30 V), impedance: 3.5 kOhm programmable |
| Number of preset speeds | 16 preset speeds |
| Discrete output number | 2.0 |

| | |
|-------------------------------------|--|
| Discrete output type | Programmable output DQ1, DQ2 30 V DC 100 mA |
| Analogue input number | 2 |
| Analogue input type | AI1 software-configurable current: 0...20 mA, impedance: 250 Ohm, resolution 12 bits AI1 software-configurable temperature probe or water level sensor AI1 software-configurable voltage: 0...10 V DC, impedance: 31.5 kOhm, resolution 12 bits AI2 software-configurable voltage: - 10...10 V DC, impedance: 31.5 kOhm, resolution 12 bits |
| Analogue output number | 2 |
| Analogue output type | Software-configurable voltage AQ1: 0...10 V DC impedance 470 Ohm, resolution 10 bits Software-configurable current AQ1: 0...20 mA impedance 500 Ohm, resolution 10 bits |
| Relay output number | 2 |
| Output voltage | <= power supply voltage |
| Relay output type | Relay outputs R1A Relay outputs R1C electrical durability 100000 cycles Relay outputs R2A Relay outputs R2C electrical durability 100000 cycles |
| Maximum switching current | Relay output R1C on resistive load, cos phi = 1: 3 A at 250 V AC Relay output R1C on resistive load, cos phi = 1: 3 A at 30 V DC Relay output R1C on inductive load, cos phi = 0.4 and L/R = 7 ms: 2 A at 250 V AC Relay output R1C on inductive load, cos phi = 0.4 and L/R = 7 ms: 2 A at 30 V DC Relay output R2C on resistive load, cos phi = 1: 5 A at 250 V AC Relay output R2C on resistive load, cos phi = 1: 5 A at 30 V DC Relay output R2C on inductive load, cos phi = 0.4 and L/R = 7 ms: 2 A at 250 V AC Relay output R2C on inductive load, cos phi = 0.4 and L/R = 7 ms: 2 A at 30 V DC |
| Minimum switching current | Relay output R1B: 5 mA at 24 V DC Relay output R2C: 5 mA at 24 V DC |
| Physical interface | 2-wire RS 485 |
| Connector type | 1 RJ45 |
| Method of access | Slave Modbus RTU |
| Transmission rate | 4.8 kbit/s 9.6 kbit/s 19.2 kbit/s 38.4 kbit/s |
| Transmission frame | RTU |
| Number of addresses | 1...247 |
| Data format | 8 bits, configurable odd, even or no parity |
| Type of polarization | No impedance |
| 4 quadrant operation possible | True |
| Asynchronous motor control profile | Constant torque standard Variable torque standard Optimized torque mode |
| Synchronous motor control profile | Permanent magnet motor Reluctance motor |
| Pollution degree | 2 conforming to EN/IEC 61800-5-1 |
| Maximum output frequency | 0.599 kHz |
| Acceleration and deceleration ramps | S, U or customized Linear adjustable separately from 0.01...9999 s |
| Motor slip compensation | Can be suppressed Not available in permanent magnet motor law Automatic whatever the load Adjustable |
| Switching frequency | 2...16 kHz adjustable 14...16 kHz with derating factor |
| Nominal switching frequency | 4 kHz |
| Braking to standstill | By DC injection |
| Brake chopper integrated | True |
| Line current | 2.6 A at 380 V (normal duty) 2.1 A at 480 V (normal duty) 3.4 A at 380 V (heavy duty) 2.6 A at 480 V (heavy duty) |
| Line current | 2.6 A at 480 V without line choke (heavy duty) 2.6 A at 380 V with external line choke (normal duty) 2.1 A at 480 V with external line choke (normal duty) 1.9 A at 380 V with external line choke (heavy duty) |

| | |
|--|---|
| | 1.6 A at 480 V with external line choke (heavy duty) 3.4 A at 380 V without line choke (heavy duty) |
| Maximum input current | 3.4 A |
| Maximum output voltage | 480 V |
| Apparent power | 2.2 kVA at 480 V (normal duty) 2.2 kVA at 480 V (heavy duty) |
| Maximum transient current | 3.1 A during 60 s (normal duty) 3.3 A during 60 s (heavy duty) 3.8 A during 2 s (normal duty) 4 A during 2 s (heavy duty) |
| Electrical connection | Screw terminal, clamping capacity: 1.5...4 mm ² for line side Screw terminal, clamping capacity: 4...6 mm ² for DC bus Screw terminal, clamping capacity: 1.5...4 mm ² for motor Screw terminal, clamping capacity: 0.2...2.5 mm ² for control |
| Prospective line I _{sc} | 5 kA |
| Base load current at high overload | 2.2 A |
| Base load current at low overload | 2.8 A |
| Power dissipation in W | Natural convection: 28 W at 380 V, switching frequency 4 kHz (heavy duty) Forced convection: 28 W at 380 V, switching frequency 4 kHz (heavy duty) Natural convection: 33 W at 380 V, switching frequency 4 kHz (normal duty) Forced convection: 33 W at 380 V, switching frequency 4 kHz (normal duty) |
| Electrical connection | Line side: screw terminal 1.5...4 mm ² /AWG 14...AWG 12 DC bus: screw terminal 4...6 mm ² /AWG 12...AWG 10 Motor: screw terminal 1.5...4 mm ² /AWG 14...AWG 12 Control: screw terminal 0.2...2.5 mm ² /AWG 24...AWG 12 |
| With safety function Safely Limited Speed (SLS) | True |
| With safety function Safe brake management (SBC/SBT) | True |
| With safety function Safe Operating Stop (SOS) | False |
| With safety function Safe Position (SP) | False |
| With safety function Safe programmable logic | False |
| With safety function Safe Speed Monitor (SSM) | False |
| With safety function Safe Stop 1 (SS1) | True |
| With sft fct Safe Stop 2 (SS2) | False |
| With safety function Safe torque off (STO) | True |
| With safety function Safely Limited Position (SLP) | False |
| With safety function Safe Direction (SDI) | False |
| Protection type | Thermal protection: motor Safe torque off: motor Motor phase loss: motor Thermal protection: drive Safe torque off: drive Overheating: drive Overcurrent: drive Output overcurrent between motor phase and earth: drive Output overcurrent between motor phases: drive Short-circuit between motor phase and earth: drive Short-circuit between motor phases: drive Motor phase loss: drive DC Bus overvoltage: drive Line supply overvoltage: drive Line supply undervoltage: drive Input supply loss: drive Exceeding limit speed: drive Break on the control circuit: drive |
| Width | 85.0 mm |
| Height | 270.0 mm |
| Depth | 232.5 mm |

| | |
|---------------------------|---|
| Net weight | 1.7 kg |
| Continuous output current | 2.2 A at 4 kHz for heavy duty 2.8 A at 4 kHz for normal duty |

Environment

| | |
|--|--|
| Operating altitude | <= 3000 m with current derating above 1000m |
| Operating position | Vertical +/- 10 degree |
| Product certifications | UL CSA TÜV EAC CTick |
| Marking | CE |
| Standards | EN/IEC 61800-3 EN/IEC 61800-5-1 IEC 60721-3 IEC 61508 IEC 13849-1 UL 618000-5-1 UL 508C |
| Assembly style | With heat sink |
| Electromagnetic compatibility | Electrostatic discharge immunity test level 3 conforming to IEC 61000-4-2 Radiated radio-frequency electromagnetic field immunity test level 3 conforming to IEC 61000-4-3 Electrical fast transient/burst immunity test level 4 conforming to IEC 61000-4-4 1.2/50 µs - 8/20 µs surge immunity test level 3 conforming to IEC 61000-4-5 Conducted radio-frequency immunity test level 3 conforming to IEC 61000-4-6 |
| Environmental class (during operation) | Class 3C3 according to IEC 60721-3-3 Class 3S3 according to IEC 60721-3-3 |
| Maximum acceleration under shock impact (during operation) | 70 m/s ² at 22 ms |
| Maximum acceleration under vibrational stress (during operation) | 5 m/s ² at 9...200 Hz |
| Maximum deflection under vibratory load (during operation) | 1.5 mm at 2...9 Hz |
| Permitted relative humidity (during operation) | Class 3K5 according to EN 60721-3 |
| Volume of cooling air | 18.0 m ³ /h |
| Type of cooling | Forced convection |
| Overvoltage category | Class III |
| Regulation loop | Adjustable PID regulator |
| Noise level | 52.7 dB |
| Pollution degree | 2 |
| Ambient air transport temperature | -40...70 °C |
| Ambient air temperature for operation | -15...50 °C without derating (vertical position) 50...60 °C with derating factor (vertical position) |
| Ambient air temperature for storage | -40...70 °C |
| Isolation | Between power and control terminals |

Packing Units

| | |
|------------------------------|----------|
| Unit Type of Package 1 | PCE |
| Number of Units in Package 1 | 1 |
| Package 1 Weight | 2.432 kg |
| Package 1 Height | 10.7 cm |
| Package 1 width | 35.3 cm |
| Package 1 Length | 28.8 cm |
| Unit Type of Package 2 | S04 |
| Number of Units in Package 2 | 2 |
| Package 2 Weight | 5.57 kg |

| | |
|------------------------------|-----------|
| Package 2 Height | 30 cm |
| Package 2 width | 40 cm |
| Package 2 Length | 60 cm |
| Unit Type of Package 3 | P06 |
| Number of Units in Package 3 | 14 |
| Package 3 Weight | 47.048 kg |
| Package 3 Height | 80 cm |
| Package 3 width | 80 cm |
| Package 3 Length | 60 cm |

Offer Sustainability

| | |
|----------------------------|---|
| Sustainable offer status | Green Premium product |
| REACH Regulation | REACH Declaration |
| EU RoHS Directive | Pro-active compliance (Product out of EU RoHS legal scope) EU RoHS Declaration |
| Mercury free | Yes |
| RoHS exemption information | Yes |
| China RoHS Regulation | China RoHS declaration |
| Environmental Disclosure | Product Environmental Profile |
| Circularity Profile | End of Life Information |
| WEEE | The product must be disposed on European Union markets following specific waste collection and never end up in rubbish bins |
| California proposition 65 | WARNING: This product can expose you to chemicals including: Lead and lead compounds, which is known to the State of California to cause cancer and birth defects or other reproductive harm. For more information go to www.P65Warnings.ca.gov |
| Upgradeability | Upgraded components available  |

Dimensions

Views: Front - Left - Rear

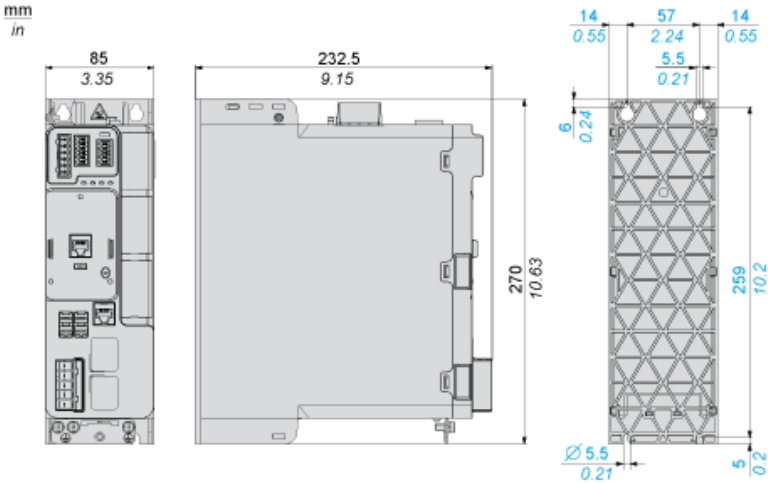

Clearance

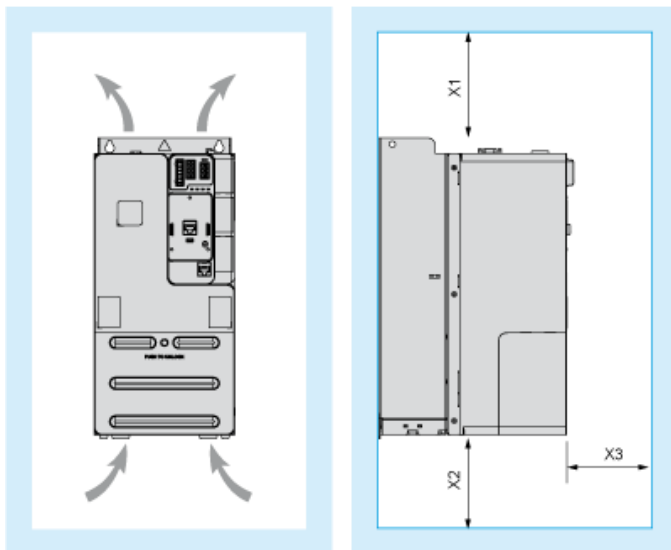

Dimensions in mm

| X1 | X2 | X3 |
|-------|-------|------|
| ≥ 100 | ≥ 100 | ≥ 60 |

Dimensions in in.

| X1 | X2 | X3 |
|--------|--------|--------|
| ≥ 3.94 | ≥ 3.94 | ≥ 2.36 |

Mounting Types

Mounting Type A: Side by Side IP20

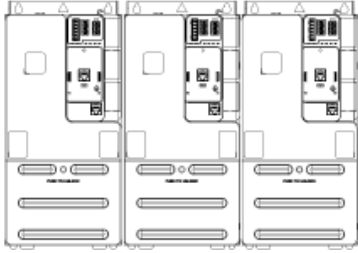

Possible, at ambient temperature $\leq 50\text{ }^{\circ}\text{C}$ (122 $^{\circ}\text{F}$)

Mounting Type B: Individual IP20

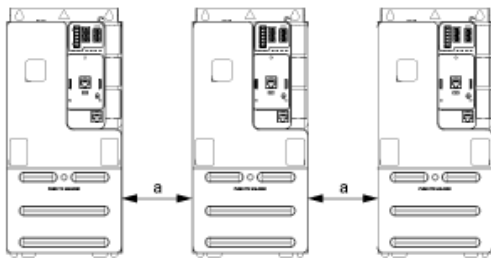

$a \geq 50\text{ mm}$ (1.97 in.) from 50...60 $^{\circ}\text{C}$, no restriction below 50 $^{\circ}\text{C}$

Connections and Schema

Three-phase Power Supply with Upstream Breaking via Line Contactor Without Safety Function STO

Connection diagrams conforming to standards ISO13849 category 1 and IEC/EN 61508 capacity SIL1, stopping category 0 in accordance with standard IEC/EN 60204-1.

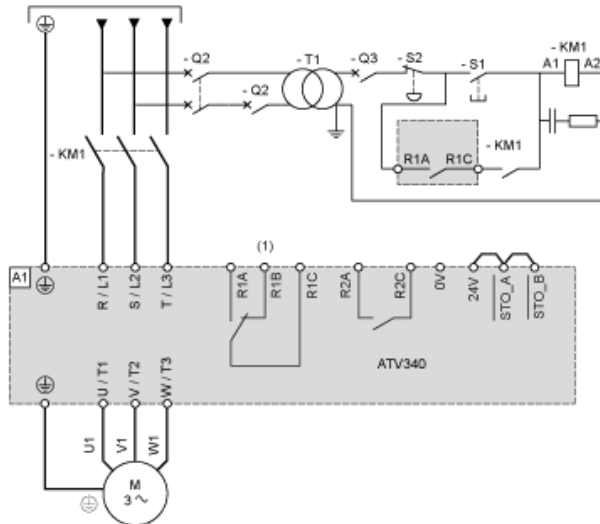

- (1) Use relay output R1 set to operating state Fault to switch Off the product once an error is detected.
- A1 : Drive
- KM1 : Line Contactor
- Q2, Q3 : Circuit breakers
- S1 : Pushbutton
- S2 : Emergency stop
- T1 : Transformer for control part

Three-phase Power Supply With Downstream Breaking via Switch Disconnecter

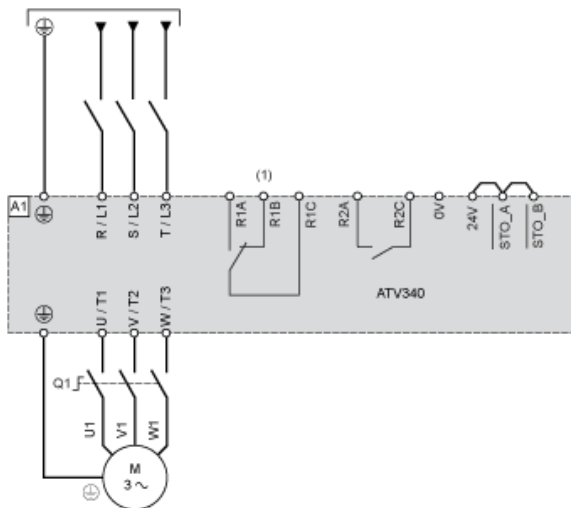

- (1) Use relay output R1 set to operating state Fault to switch Off the product once an error is detected.
- A1 : Drive
- Q1 : Switch disconnecter

Sensor Connection

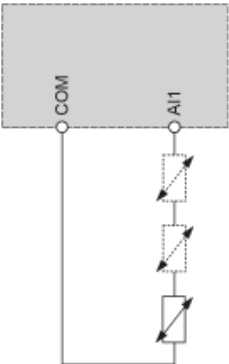

It is possible to connect either 1 or 3 sensors on terminals AI1.

Control Block Wiring Diagram

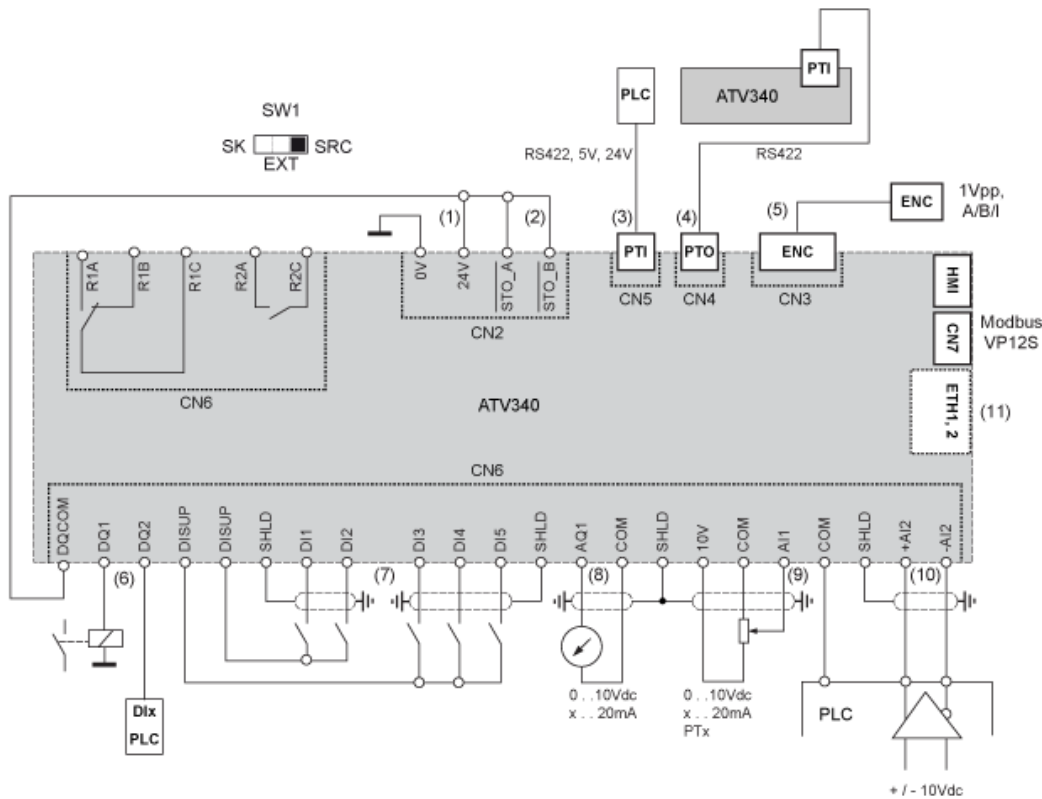

- (1) 24V supply (STO)
 - (2) STO - Safe Torque Off
 - (3) PTI - Pulse Train In
 - (4) PTO - Pulse Train Out
 - (5) Motor Encoder connection
 - (6) Digital outputs
 - (7) Digital inputs
 - (8) Analog output
 - (9) Analog input
 - (10) Differential Analog Input
 - (11) Ethernet port (only on Ethernet drive version)
- SW1 : Sink/Source switch
 R1A, R1B, R1C Relay
 R2A, R2C Sequence relay

Digital Inputs Wiring

Digital Inputs: Internal Supply

Using DISUP Signal

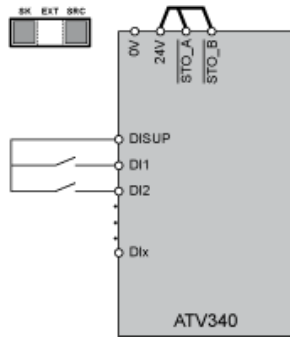

In SRC position DISUP outputs 24 V. In SK position DISUP is connected to 0 V.

Digital Inputs: External Supply

Positive Logic, Source, European Style

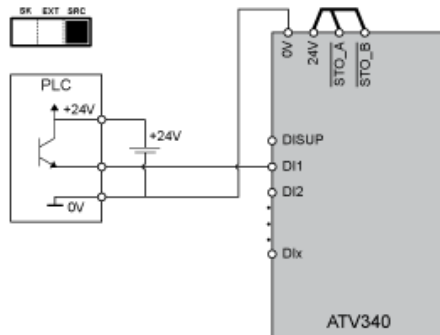

Negative Logic, Sink, Asian Style

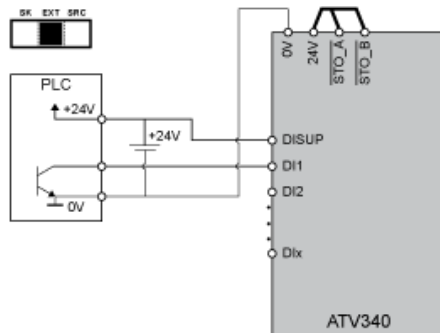

Digital Inputs: Internal supply

Negative Logic, Sink, Asian Style

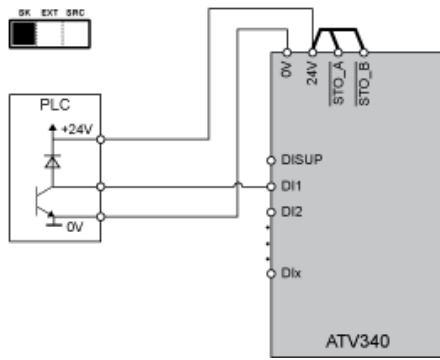

Digital Outputs Wiring

Digital Outputs: Internal Supply

Positive Logic, Source, European Style, DQCOM to +24V

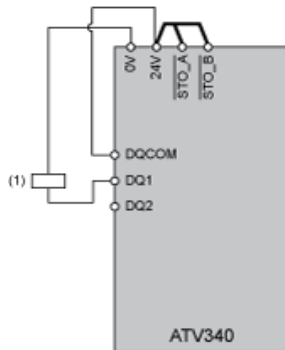

(1) Relay or valve

Negative Logic, Sink, Asian Style, DQCOM to 0V

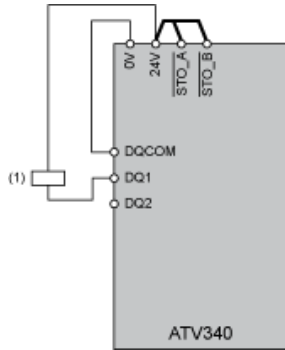

(1) Relay or valve

Digital Outputs: External Supply

Positive Logic, Source, European Style, DQCOM to +24V

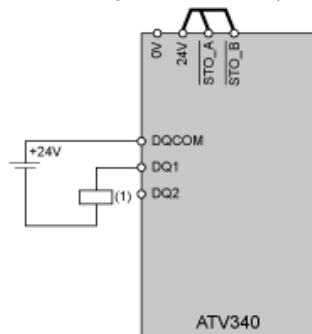

(1) Relay or valve

Negative Logic, Sink, Asian Style, DQCOM to 0V

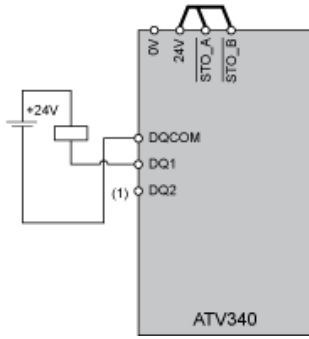

(1) Relay or valve

Open Loop Applications

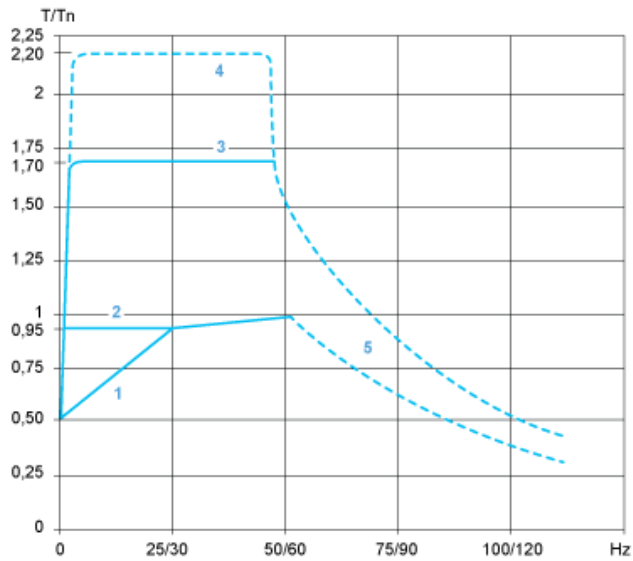

- 1 : Self-cooled motor: continuous useful torque
- 2 : Force-cooled motor: continuous useful torque
- 3 : Overtorque for 60 s maximum
- 4 : Transient overtorque for 2 s maximum
- 5 : Torque in overspeed at constant power

Closed Loop Applications

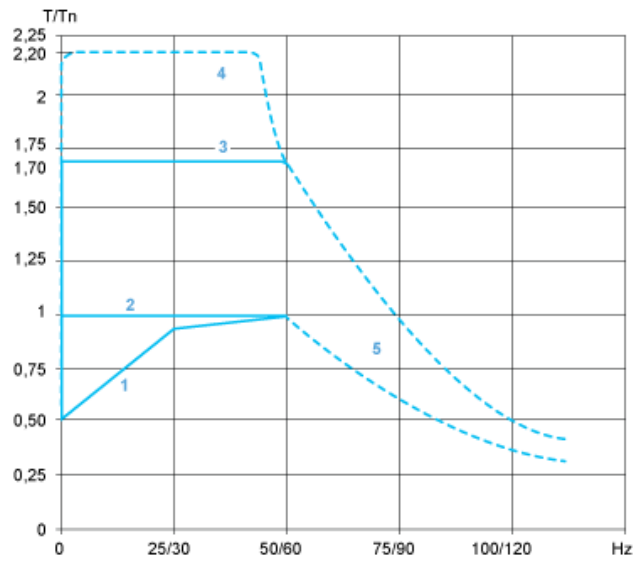

- 1 : Self-cooled motor: continuous useful torque
- 2 : Force-cooled motor: continuous useful torque
- 3 : Overtorque for 60 s maximum
- 4 : Transient overtorque for 2 s maximum
- 5 : Torque in overspeed at constant power