

Manuale d'uso

IX58, IX58S CX58, CX59

Certificazione ATEX cat. 3
per zone 2, 22



II3 GD, Ex nA IIB T5 Gc, Ex tc IIIC T100° Dc, IP65

Elenco sezioni

- 1 - Norme di sicurezza
- 2 - Identificazione
- 3 - Installazione meccanica
- 4 - Connessioni elettriche
- 5 - Certificati

1 - Norme di sicurezza



1.1 Sicurezza

- Attenersi scrupolosamente alle informazioni in questo manuale relative ai prodotti ATEX;
- durante l'installazione e l'utilizzo del dispositivo osservare le norme di prevenzione e sicurezza sul lavoro previste nel proprio paese;
- l'installazione e le operazioni di manutenzione devono essere eseguite da personale qualificato, in assenza di tensione e parti meccaniche in movimento;
- utilizzare il dispositivo esclusivamente per la funzione per cui è stato costruito: ogni altro utilizzo potrebbe risultare pericoloso per l'utilizzatore;
- alte correnti, tensioni e parti in movimento possono causare lesioni serie o fatali;
- il mancato rispetto delle norme di sicurezza o delle avvertenze specificate in questo manuale è considerato una violazione delle norme di sicurezza standard previste dal costruttore o richieste dall'uso per cui lo strumento è destinato;
- Lika Electronic non si assume alcuna responsabilità per eventuali danni o lesioni derivanti dall'inosservanza delle norme di sicurezza da parte dell'utilizzatore.



1.2 Avvertenze elettriche

- Effettuare le connessioni elettriche esclusivamente in assenza di tensione;
- rispettare le connessioni riportate nella sezione "4 - Connessioni elettriche";
- i fili dei segnali d'uscita non utilizzati devono essere isolati singolarmente;
- in riferimento alla normativa 2014/30/UE sulla compatibilità elettromagnetica rispettare le seguenti precauzioni:
 - prima di maneggiare e installare il dispositivo eliminare la presenza di carica elettrostatica dal proprio corpo e dagli utensili che andranno a contatto con il dispositivo;
 - alimentare il dispositivo con tensione stabilizzata e priva di disturbi; se necessario, installare appositi filtri EMC in ingresso all'alimentazione;
 - utilizzare sempre cavi schermati e possibilmente "twistati";
 - non usare cavi più lunghi del necessario;
 - evitare di far passare il cavo dei segnali del dispositivo vicino a cavi di potenza;
 - installare il dispositivo il più lontano possibile da possibili fonti di interferenza o schermarlo in maniera efficace;
 - per garantire un funzionamento corretto del dispositivo, evitare l'utilizzo di apparecchiature con forte carica magnetica in prossimità dell'unità;
 - per la messa a terra utilizzare il punto di fissaggio predisposto sul corpo dell'encoder (si vedano le Figure a pagina 3). Assicurare il cavo di messa a terra al punto di fissaggio mediante un capicorda a occhiello e bullone M4. Il collegamento a terra può essere eventualmente effettuato anche sul lato utilizzatore collegando la calza del cavo al punto di terra; è compito dell'utilizzatore valutare la soluzione migliore da adottare per minimizzare i disturbi. Assicurarsi che il punto di terra sia privo di disturbi;
- la tensione di alimentazione nominale non deve superare i 30Vdc;
- se il collegamento elettrico avviene in zona classificata, deve essere eseguito adottando uno dei metodi previsti dalla norma EN 60079-0;
- l'utilizzatore deve prevedere misure adeguate al fine di prevenire che disturbi prolungati o continui possano incrementare la tensione di alimentazione oltre il 10%;
- il prodotto deve essere protetto da surriscaldamenti provocati da sovraccarichi elettrici.



1.3 Avvertenze meccaniche

- Montare il dispositivo rispettando rigorosamente le istruzioni riportate nella sezione "3 - Installazione meccanica";
- effettuare il montaggio meccanico esclusivamente in assenza di parti meccaniche in movimento;
- non disassemblare il dispositivo e non eseguire lavorazioni meccaniche sul dispositivo;
- dispositivo elettronico delicato: maneggiare con cura; evitare urti o forti sollecitazioni sia all'asse che al corpo del dispositivo;
- utilizzare il dispositivo in accordo con le caratteristiche ambientali previste dal costruttore;
- encoder con asse sporgente: utilizzare giunti elastici per collegare encoder e motore; rispettare le tolleranze di disallineamento ammesse dal giunto elastico;
- encoder con asse cavo: l'encoder può essere montato direttamente su un albero che rispetti le caratteristiche definite nel foglio d'ordine e fissato mediante il collare e, ove previsto, un pin antirotazione;
- il prodotto deve essere protetto da surriscaldamenti provocati da sovraccarichi meccanici;
- questo prodotto non ottempera ai requisiti delle "prove di resistenza all'impatto" stabiliti da EN60079-0, sezione 26.4.2, ma può essere utilizzato in zone 2/22 se provvisto di adeguate protezioni.



1.4 Avvertenze di utilizzo

- I dispositivi descritti sono certificati di categoria 3 per l'installazione in zone potenzialmente esplosive 2 (secondo EN60079-15) e 22 (secondo EN60079-31). Sono idonei a garantire la sicurezza in ambienti di lavoro in cui, durante la normale attività, sia poco probabile, e comunque di breve durata, la formazione di una miscela esplosiva di gas e vapori (zona 2) o di polveri nell'aria (zona 22). Ottemperano ai requisiti di sicurezza costruttiva della classe di temperatura T5 (T100°C). **Non possono essere utilizzati in zone 0, 1 e 21;**

- requisiti di protezione: Zona 2, protezione da gas esplosivi (G): la costruzione minimizza l'evenienza di scintille, archi elettrici e superfici calde che durante il normale funzionamento potrebbero innescare un'esplosione; Zona 22, protezione da polveri esplosive (D): la costruzione protegge dalla penetrazione di polvere in quantità pericolose (min. IP5x) e garantisce che la temperatura superficiale sia inferiore alla temperatura di innesco di miscele di polvere/aria e alla temperatura di combustione latente di depositi di polvere;
- non superare mai i valori indicati nelle specifiche tecniche del prodotto (temperature, velocità, ...);
- max. temperatura di lavoro ammessa: +70°C (a una velocità di rotazione continua di 6000 rpm max.);
- la massima temperatura superficiale non deve superare i 2/3 della temperatura di innesco della miscela di polvere/aria;
- in funzionamento continuo le componenti plastiche devono resistere a una temperatura di 10°C superiore a quella massima che il prodotto può raggiungere nel punto più caldo e in funzionamento alla massima temperatura ambientale.

2 - Identificazione

Il dispositivo è identificato mediante un **codice di ordinazione** e un **numero di serie** stampati sull'etichetta applicata al dispositivo stesso; i dati sono ripetuti anche nei documenti di trasporto che lo accompagnano. Citare sempre il codice di ordinazione e il numero di serie quando si contatta Lika Electronic per l'acquisto di un ricambio o nella necessità di assistenza tecnica. Per ogni informazione sulle caratteristiche tecniche del dispositivo fare riferimento al catalogo del prodotto.



Attenzione: gli encoder con codice di ordinazione finale "/Sxxx" possono avere caratteristiche meccaniche ed elettriche diverse dallo standard ed essere provvisti di documentazione aggiuntiva per cablaggi speciali (Technical info).

3 - Installazione meccanica

3.1 Dimensioni di ingombro encoder IX58

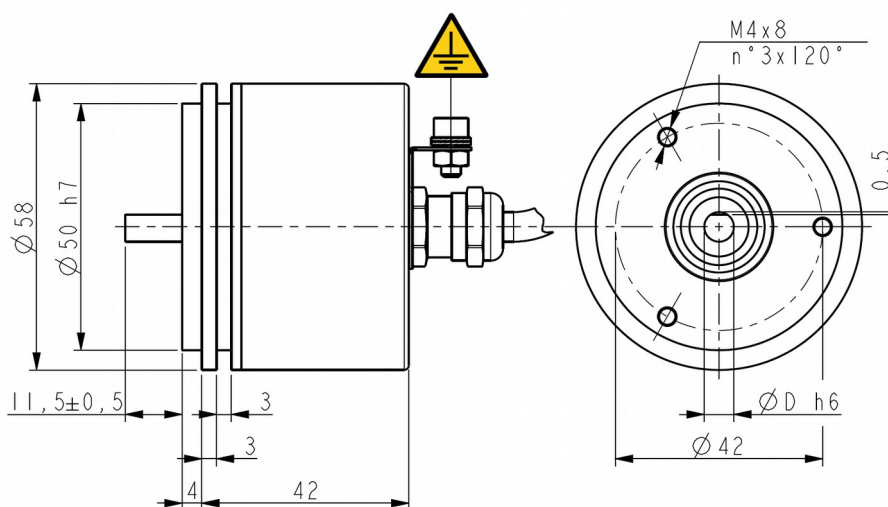

3.2 Dimensioni di ingombro encoder IX58S

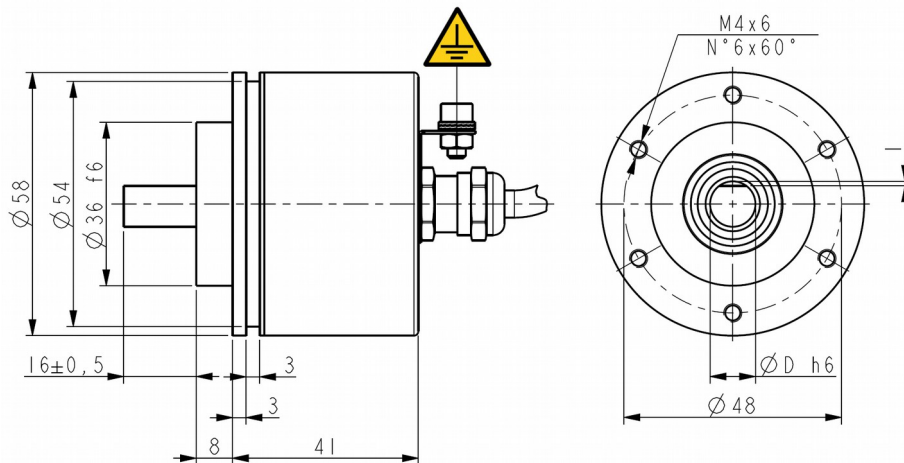

3.3 Dimensioni di ingombro encoder CX58

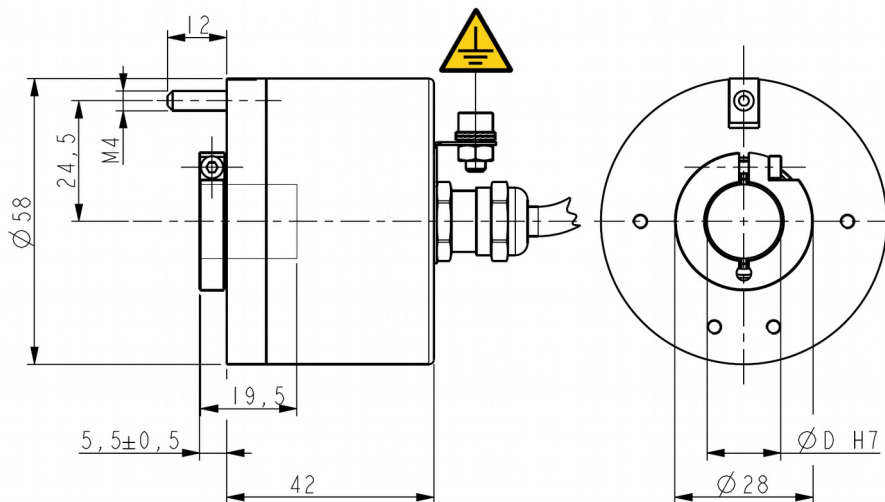

3.4 Dimensioni di ingombro encoder CX59

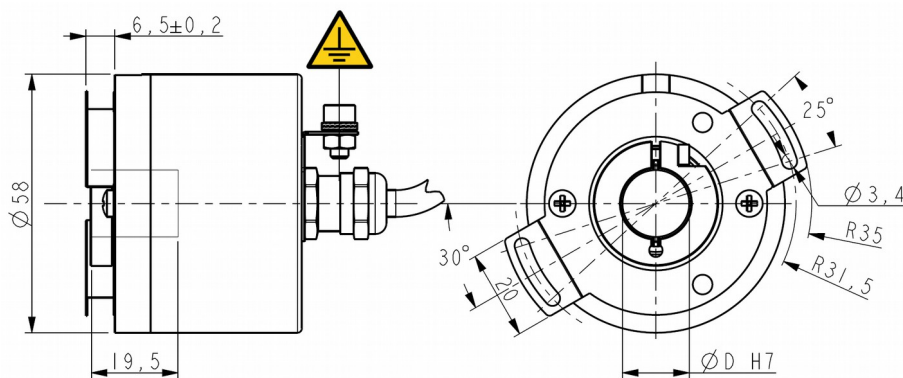

3.5 Istruzioni di montaggio



ATTENZIONE

L'installazione e le operazioni di manutenzione devono essere eseguite da personale qualificato, in assenza di tensione e componenti meccaniche in movimento.

Non forzare manualmente la rotazione dell'albero al fine di evitare danni permanenti!

Per ulteriori informazioni riferirsi anche alle sezioni "1 - Norme di sicurezza" a pagina 1 e "5 - Certificati" a pagina 11.

3.5.1 Encoder con asse sporgente IX58 e IX58S

- Fissare il giunto elastico **1** all'encoder;
- fissare l'encoder alla flangia di fissaggio **2** o alla campana utilizzando le viti M4 **3**;
- fissare la flangia **2** al supporto o la campana al motore;
- fissare il giunto elastico **1** al motore;
- assicurarsi che le tolleranze di disallineamento ammesse dal giunto elastico **1** siano rispettate.

3.5.1.1 Fissaggio standard - IX58 e IX58S

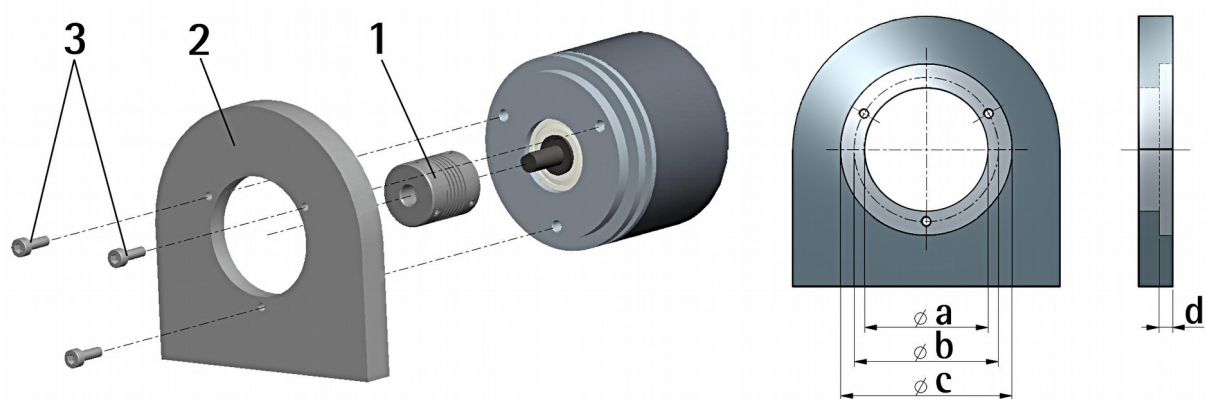

	a [mm]	b [mm]	c [mm]	d [mm]
IX58	-	42	50 F7	4
IX58S	36 H7	48	-	-

3.5.1.2 Fissaggio con graffe (codice LKM-386) – IX58 e IX58S

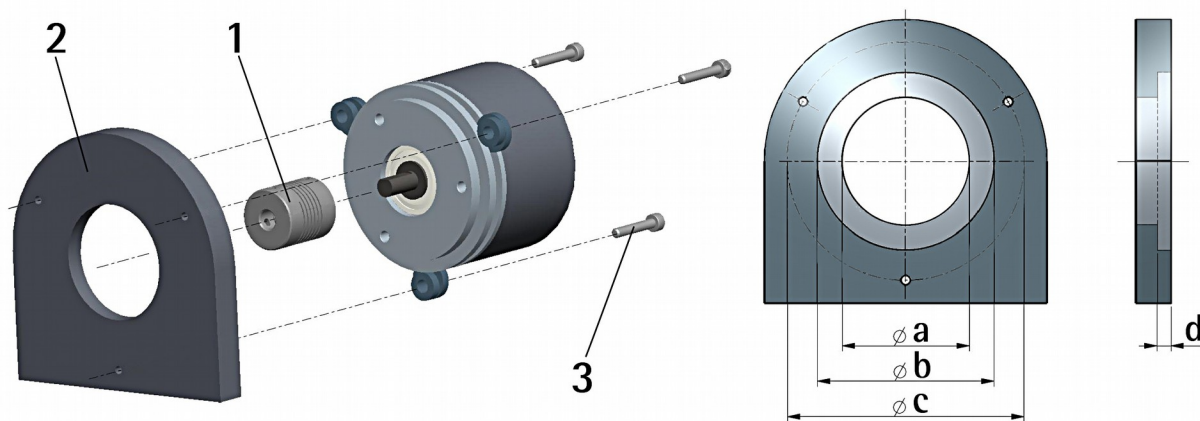

	a [mm]	b [mm]	c [mm]	d [mm]
IX58	-	50 F7	67	4
IX58S	36 H7	-	67	-

3.5.1.3 Fissaggio con campana (codice PF4256) – IX58S

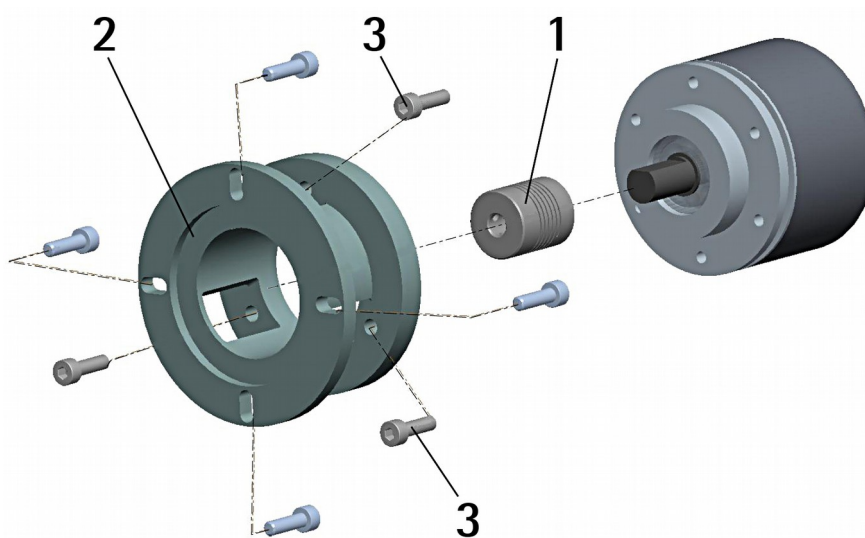

NOTA

Si raccomanda di utilizzare giunti elastici per collegare l'encoder al motore; assicurarsi che le tolleranze di disallineamento ammesse dal giunto elastico 1 siano rispettate.

3.5.2 Encoder con asse cavo CX58 e CX59

3.5.2.1 CX58 con pin antirotazione

- Fissare il pin antirotazione **1** sul retro del motore (fissaggio con controdamo);
- inserire l'encoder sull'albero del motore utilizzando la boccola di riduzione BR1 **8** (se fornita); evitare sforzi sull'albero encoder;
- inserire il pin antirotazione **1** nella fresatura della flangia encoder; esso rimane così in posizione grazie al grano **2** prefissato da Lika;
- fissare il collare **3** dell'albero encoder (fissare la vite **3** con frenafiletto).

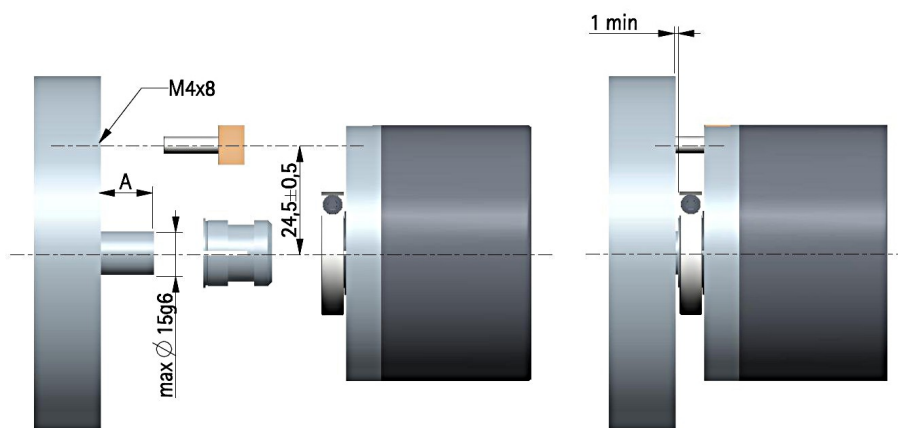
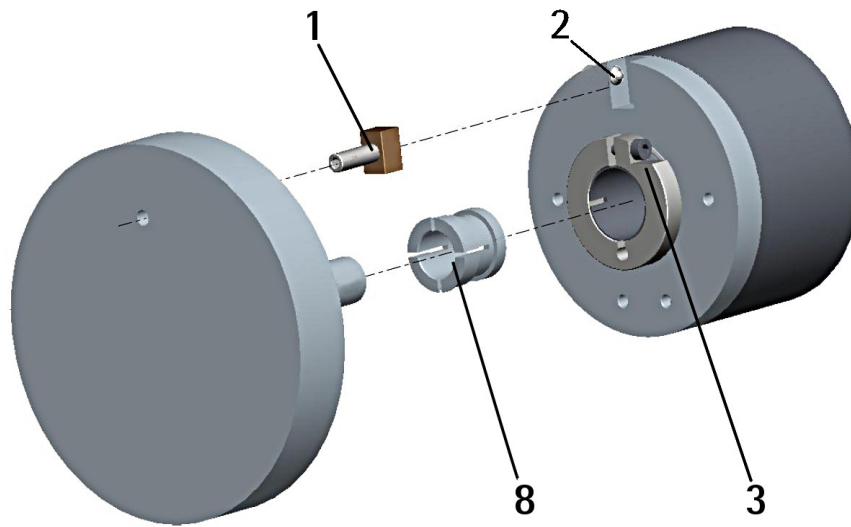

A: min. 8 mm, max. 18 mm

3.5.2.2 CX59 con molla di fissaggio

- Rimuovere il pin antirotazione **1** (si consultino le informazioni alla pagina precedente);
- inserire l'encoder sull'albero del motore utilizzando la boccola di riduzione BR1 **8** (se fornita); evitare sforzi sull'albero encoder;
- fissare la molla di fissaggio **4** sul retro del motore utilizzando due viti M3 a testa cilindrica **5**;

- fissare il collare 3 dell'albero encoder (fissare la vite 3 con frenafiletto).

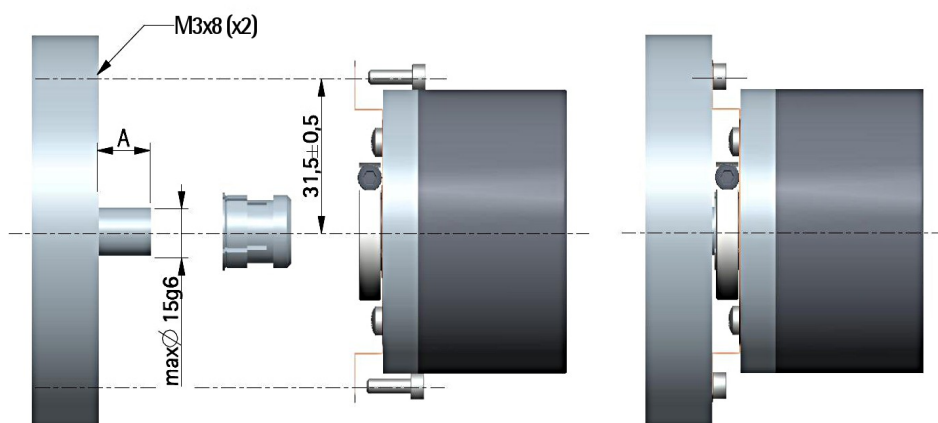
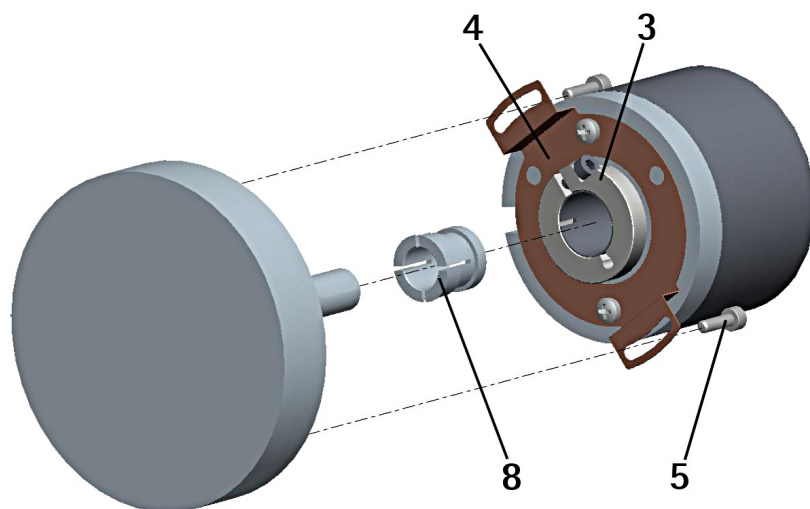

A: min. 8 mm, max. 18 mm



NOTA

Si raccomanda di non eseguire lavorazioni meccaniche con trapani o fresatrici sull'albero dell'encoder. Si potrebbero procurare danni irreparabili ai componenti interni con immediata perdita della garanzia. Si prega di contattare il nostro servizio tecnico per ogni informazione sulla gamma disponibile di alberi "personalizzati".

4 - Connessioni elettriche



ATTENZIONE

Se il collegamento elettrico avviene in zona classificata, deve essere eseguito adottando uno dei metodi previsti dalla norma EN 60079-0. La tensione di alimentazione nominale non può essere superiore a 30Vdc. L'utilizzatore deve prevedere misure adeguate al fine di prevenire che disturbi prolungati o continui possano incrementare la tensione di alimentazione oltre il 10%. Per ulteriori informazioni riferirsi anche alle sezioni "1 - Norme di sicurezza" a pagina 1 e "5 - Certificati" a pagina 11.



ATTENZIONE

Effettuare le connessioni elettriche esclusivamente in assenza di tensione.



ATTENZIONE

La chiusura di contatto tra i segnali non utilizzati può provocare il danneggiamento irrimediabile del dispositivo. I cavi dei segnali non utilizzati devono essere tagliati a lunghezze diverse e isolati singolarmente.

4.1 Collegamento messa a terra

Per la messa a terra dell'encoder utilizzare il punto di fissaggio predisposto sul corpo dell'encoder (si vedano le Figure a pagina 3 e segg.). Assicurare il cavo di messa a terra al punto di fissaggio mediante un capicorda a occhiello e bullone M4. Il collegamento a terra può essere eventualmente effettuato anche sul lato utilizzatore collegando la calza del cavo al punto di terra; è compito dell'utilizzatore valutare la soluzione migliore da adottare per minimizzare ogni interferenza. Assicurarsi che il punto di terra sia privo di disturbi.

4.2 IX58-/CX58-...ZNF...

Circuiti d'uscita N, P, Y, L, H



Funzione	Cavo I5
A	Marrone
B	Blu
0	Bianco
+Vdc alimentazione *	Rosso
0Vdc alimentazione	Nero
Schermatura	Calza

* Per la tensione di alimentazione si veda il codice di ordinazione.



ESEMPIO

IX58-L-4096ZNF1... +Vdc = +5Vdc ± 5%

IX58-H-4096ZNF4... +Vdc = +5Vdc +30Vdc

4.2.1 Caratteristiche del cavo I5

Modello	: cavo LIKA encoder cable type I5
Conduttori	: 5 x 0,22 mm ² (24/7 AWG)
Guaina	: PVC, ignifugo
Schermo	: a nastro di alluminio/poliestere, copertura > 120% e conduttore flessibile di continuità in rame stagnato 24/7AWG
Diametro esterno	: 4,5 mm ± 0,1 mm
Raggio di curvatura	: Ø esterno x 10 min.
Temperatura di lavoro	: -20°C +80°C
Resistenza elettrica	: < 90 Ω/km

4.3 IX58-/CX58-...ZCU...

Circuiti d'uscita N, P, Y, L, H, V



Funzione	Cavo I8
A	Giallo
/A	Blu
B	Verde
/B	Arancione
0	Bianco
/0	Grigio
+Vdc alimentazione *	Rosso
0Vdc alimentazione	Nero
Schermatura	Calza

* Per la tensione di alimentazione si veda il codice di ordinazione.



ESEMPIO

IX58-L-4096ZCU1... +Vdc = +5Vdc ± 5%
 IX58-H-4096ZCU4... +Vdc = +5Vdc +30Vdc

4.3.1 Caratteristiche del cavo I8

Modello	: cavo LIKA encoder cable type I8
Conduttori	: 8 x 0,22 mm ² (24/7 AWG)
Guaina	: PVC, ignifugo
Schermo	: a nastro di alluminio/poliestere, copertura > 120% e conduttore flessibile di continuità in rame stagnato 24/7AWG
Diametro esterno	: 5,1 mm ± 0,1 mm
Raggio di curvatura	: Ø esterno x 10 min.
Temperatura di lavoro	: -20°C +80°C
Resistenza elettrica	: < 90 Ω/km

5 – Certificati

5.1 Dichiarazione di conformità ATEX



Lika Electronic Srl
Via S. Lorenzo, 25
36010 Carrè (VI) • Italy

Smart encoders & actuators

Carre', 31.08.2015

Declaration of Conformity

The manufacturer:
LIKA ELECTRONIC SRL
Via S. Lorenzo, 25
36010 Carrè (VI) – Italy

hereby declares that the following products:

Lika encoder series **IX58, IX58S, CX58, CX59**

with the marking:

Ex II 3G Ex nA IIB T5 Gc
EX II 3D Ex tc IIIC T100° Dc IP65

may be used in Zone 2 and Zone 22 hazardous areas.

Gas explosion protected equipment for Zone 2, according to EN60079-15
Zone 2 includes areas in which an explosive atmosphere consisting of a mixture with air of flammable substances in the form of gas or vapour is not likely to occur in normal operation but, if it does occur, will persist for a short period only.

Dust explosion protected equipment for Zone 22, according to EN60079-31
Zone 22 includes areas in which an explosive atmosphere in the form of a cloud of dust in air is not likely to occur in normal operation but, if it does occur, will persist for a short period only.

Lika Electronic Srl
Smart encoders & actuators



Headquarters & Plant
Via S. Lorenzo, 25
36010 Carrè (VI) • Italy

Tel. +39 0445 806600
Fax +39 0445 806699
info@lika.biz • www.lika.biz

P.I./C.F. IT 00817760242
VAT # IT 00817760242
R.E.A. 165423/Vicenza

Protection requirements:

Zone 22, dust explosion protection (D)

Protection by means of the housing: the construction of the product protects against the penetration of dust in hazardous quantities (min. IP5x) and guarantees that the surface temperature is under the ignition temperature of dust/air mixtures as well as under the smouldering temperature of dust deposits.

Zone 2, gas explosion protection (G)

Protection by non sparking equipment: the construction minimizes the occurrence of sparks, arcs or hot surfaces, which in normal operation might give the risk of explosion.

The manufacturer's specification of the purchased product such as operating temperature, shaft rotational speed, shaft load, max. supply voltage, etc must under no circumstances be exceeded.

Protection requirements for rotary encoders of category 3GD:

- The product must be correctly assembled (encoder body and connection cap)
- The degree of protection in the installs condition must be at least IP6x.
- The maximum surface temperature (in °C) of the product must not exceed 2/3 of the ignition temperature of the dust/air mixture.
- During normal operation no sparks, arcs and non-permissible temperatures should occur.
- The upper continuous operating temperature of plastic parts must be 10°C higher the maximum temperature that can arise at the hottest point of the product, based on the highest environmental temperature possible in service.

Obligations of the user:

- The rated supply voltage must not exceed 30Vdc.
- The manufacturer's specification concerning the operating temperature range (see product data sheet) has to be fully observed.
- The product must be protected against overheating due to mechanical or electrical overloading.
- The user has to take suitable measures in order to prevent longer or continuous disturbances that cause the supply voltage to exceeded by 10% or more.
- The user has the obligation to protect in an appropriate way the area where electrical connections are carried out (make sure the product is not connected to power supply when connecting) and ensure that this area also complies with Zone 2/22 requirements.
- The listed products do not meet the "impact test" requirements of EN60079-0, section 26.4.2. but can however be used in Zone 2/22 areas where the user ensures that impacts are avoided by appropriate protection.

LIKA Electronic SRL



Marco CALABRESE
Managing Director

Lika Electronic Srl
Smart encoders & actuators



30 YEARS
YOUNG
1982.2012

Headquarters & Plant
Via S. Lorenzo, 25
36010 Carrè (VI) • Italy

Tel. +39 0445 806600
Fax +39 0445 806699
info@lika.biz • www.lika.biz

P.I./C.F. IT 00817760242
VAT # IT 00817760242
R.E.A. 165423/Vicenza

5.2 Dichiarazione di Conformità UE



Lika Electronic Srl
Via S. Lorenzo, 25
36010 Carrè (VI) • Italy
Smart encoders & actuators

**EU Declaration of Conformity encoders series
IX58, IX58S, CX58, CX59**

- 1) Certificate: Nr. 6
- 2) Manufacturer: LIKA ELECTRONIC SRL
Via S. Lorenzo, 25
36010 Carrè (VI) - Italy
VAT# IT00817760242
- 3) Scope of the certificate: encoder series **IX58, IX58S, CX58, CX59**
- 4) This certificate has been issued under the responsibility of the manufacturer indicated in point 2).
- 5) The scope of the certificate indicated in point 3) is in conformity with the essential Health and Safety regulations and legislative regulations of the directives:
 - 2014/34/EU "ATEX"
 - 2014/30/EU "Electromagnetic compatibility"
- 6) Compliance to harmonized regulations, technical specifications and other documents is assured by compliance to the following norms:
 - EN 60079-0
 - EN 60079-31
 - EN 61000-6-4, EN 61000-6-2
 - EN 60079-15
- 7) ATEX marking on the equipment:



II3 GD, Ex nA IIB T5 Gc, Ex tc IIIC T100° Dc, IP65

Carrè, 20.04.2016



Marco CALABRESE
Legal representative

Lika Electronic Srl
Smart encoders & actuators



Headquarters & Plant
Via S. Lorenzo, 25
36010 Carrè (VI) • Italy

Tel. +39 0445 806600
Fax +39 0445 806699
info@lika.biz • www.lika.biz

P.I./C.F. IT 00817760242
VAT # IT 00817760242
R.E.A. 165423/Vicenza

5.3 Istruzioni di sicurezza

**SAFETY INSTRUCTIONS encoders series
IX58, IX58S, CX58, CX59**

1) Marking:

II3 GD, Ex nA IIB T5 Gc, Ex tc IIIC T100° Dc, IP65

Explosion-proof encoder manufactured according to the following regulations:

EN 60079-0
EN 60079-31
EN 61000-6-4, EN 61000-6-2
EN 60079-15

- **Ex:** Equipment for use in potentially explosive atmospheres
- **d:** Protection by explosion-proof housing
- **IIB:** Electrical apparatus for use in potentially explosive atmospheres other than mines susceptible to firedamp.
- **T5:** Maximum housing surface temperature 100°C
- **Gc:** Level of protection (EPL). The equipment can be used in Zone 2.
- **tc:** Electrical apparatus with protective housing for use in the presence of combustible dust.
- **IIIC:** Equipment or protective housing intended for use in potentially explosive atmospheres with presence of combustible dust.
- **T100°C:** Maximum surface temperature.
- **Dc:** Level of protection (EPL). The equipment can be used in Zone 22.
- **IP65:** Degree of IP protection for dust-proof housing.

Equipment intended for use in the following Zones:

Zone 2: Mixture of gas/air, vapour/air, mist/air,

Zone 22: Mixture of dust/air

ATTENTION: Equipment not to be used in Zone 0, 1 and 21



Lika Electronic Srl
Via S. Lorenzo, 25
36010 Carrè (VI) • Italy

Smart encoders & actuators

- 2) The equipment has to be installed only by qualified personnel and according to the applicable regulations.
- 3) Do not tool or drill the equipment
- 4) Do not open the equipment
- 5) Do not loosen or unscrew the cable-press
- 6) Use the encoder's fixing pin or plate (CX58, CX59) for installation and against rotation
- 7) Protect the device against shock and mechanical damages
- 8) Use the product according to the indicated degree of IP protection
- 9) Maximum permissible environmental temperature +70°C (at continuous rotational speed of max. 6000 rpm)
- 10) In classified areas the electrical connection of the device has to be carried out according to the methods of EN 60079-0.
- 11) Connect the device according to the electrical connections scheme on the user manual
- 12) Provide a ground connection (GND) using the ground screw on the housing

LIKA ELECTRONIC SRL
Carrè', 31.08.2015

Lika Electronic Srl
Smart encoders & actuators



Headquarters & Plant
Via S. Lorenzo, 25
36010 Carrè (VI) • Italy

Tel. +39 0445 806600
Fax +39 0445 806699
info@lika.biz • www.lika.biz

P.I./C.F. IT 00817760242
VAT # IT 00817760242
R.E.A. 165423/Vicenza

Versione	Data	Descrizione	HW	SW	Interfaccia
1.0	22.09.2015	Prima stampa			
1.1	29.07.2016	Aggiornamento Dichiarazione di Conformità UE, aggiornamento norma compatibilità elettromagnetica			



Dispose separately

lika

Lika Electronic

Via S. Lorenzo, 25 • 36010 Carrè (VI) • Italy

Tel. +39 0445 806600

Fax +39 0445 806699



info@lika.biz • www.lika.biz

User's manual

IX58, IX58S CX58, CX59

ATEX cat. 3 certification
for zones 2, 22



II3 GD, Ex nA IIB T5 Gc, Ex tc IIIC T100° Dc, IP65

Table of Contents

- 1 - Safety summary
- 2 - Identification
- 3 - Mechanical installation
- 4 - Electrical connections
- 5 - Certificates



1 - Safety summary

1.1 Safety

- Always comply with the information in this manual concerning the ATEX products;
- always adhere to the professional safety and accident prevention regulations applicable to your country during device installation and operation;
- installation and maintenance operations must be carried out by qualified personnel only, with power supply disconnected and stationary mechanical parts;
- device must be used only for the purpose appropriate to its design: use for purposes other than those for which it has been designed could result in serious personal and/or the environment damage;
- high current, voltage and moving mechanical parts can cause serious or fatal injury;
- failure to comply with these precautions or with specific warnings elsewhere in this manual violates safety standards of design, manufacture, and intended use of the equipment;
- Lika Electronic assumes no liability for the customer's failure to comply with these requirements.



1.2 Electrical safety

- Turn off power supply before connecting the device;
- connect in accordance with the explanation in the "4 - Electrical connections" section;
- wires of output signals which are not used must be insulated singularly;
- in compliance with the 2014/30/EU norm on electromagnetic compatibility, following precautions must be taken:
 - before handling and installing, discharge electrical charge from your body and tools which may come in touch with the device;
 - power supply must be stabilized without noise, install EMC filters on device power supply if needed;
 - always use shielded cables (twisted pair cables whenever possible);
 - avoid cables runs longer than necessary;
 - avoid running the signal cable near high voltage power cables;
 - mount the device as far as possible from any capacitive or inductive noise source, shield the device from noise source if needed;
 - to guarantee a correct working of the device, avoid using strong magnets on or near by the unit;
 - use the connection point provided in the encoder's enclosure (see the Figures on page 19) to connect the unit to ground. Fix the ground cable to the connection point by means of a ring crimp terminal and a M4 bolt. The connection point to ground might be provided also on the installation side by connecting the cable shield to the earth point. It is user's duty to find the best solution to minimize the interference. Please make sure that ground is not affected by noise;
- the rated supply voltage must not exceed 30Vdc;
- in classified areas the electrical connection of the device must be carried out in compliance with the methods stated in the EN 60079-0 regulation;
- the user has to take suitable measures in order to prevent longer or continuous disturbances that cause the supply voltage to exceed by 10% or more;
- the product must be protected against overheating due to electrical overloading.



1.3 Mechanical safety

- Install the device complying strictly with the information in the "3 – Mechanical installation" section;
- mechanical installation must be carried out with stationary mechanical parts;
- do not disassemble the encoder and do not tool the encoder or its shaft;
- delicate electronic equipment: handle with care; do not subject the device and the shaft to knocks or shocks;
- respect the environmental characteristics declared by manufacturer;
- unit with solid shaft: in order to guarantee the maximum reliability over time of the mechanical parts, we recommend a flexible coupling to be installed to connect the encoder and the installation shaft; make sure the misalignment tolerances of the flexible coupling are respected;
- unit with hollow shaft: the encoder can be mounted directly on a shaft whose diameter has to respect the technical characteristics specified in the purchase order and clamped by means of the collar and the fixing plate into which an anti-rotation pin has to be inserted;
- the product must be protected against overheating due to mechanical overloading;
- the product does not meet the "impact test" requirements of EN60079-0, section 26.4.2, but can however be used in Zone 2/22 areas where the user ensures that impacts are avoided by appropriate protection.



1.4 Operational safety

- The described products are category 3 certified and are designed for use in potentially explosive zones 2 (according to EN60079-15) and 22 (according to EN60079-31). They are suitable for a safe use and a normal level of protection in areas in which explosive atmospheres caused by mixture of gases and vapors (zone 2) or dust (zone 22) are unlikely to occur and if they do occur do so for a short period of time. They comply with the constructional safety requirements of the temperature class T5 (T100°C = +212°F). **They are not to be used in Zones 0, 1 and 21;**

- protection requirements: Zone 2, gas explosion protection (G): protection by non sparking equipment: the construction minimizes the occurrence of sparks, arcs or hot surfaces, which in normal operation might give the risk of explosion; Zone 22, dust explosion protection (D): the construction of the product protects against the penetration of dust in hazardous quantities (min. IP5x) and guarantees that the surface temperature is under the ignition temperature of dust/air mixture as well as under the smoldering temperature of dust deposits;
- the manufacturer's specifications (temperature, speed, ...) must under no circumstances be exceeded;
- max. permissible environmental temperature: +70°C (+158°F) at continuous rotational speed of max. 6000 rpm;
- the maximum surface temperature (in °C) of the product must not exceed 2/3 of the ignition temperature of the dust/air mixture;
- in continuous operation the plastic parts must be able to withstand a temperature 10°C higher than the maximum temperature that can be reached in the hottest point of the product while the environmental temperature is the highest allowed during operation.

2 - Identification

Device can be identified through the **order code** and the **serial number** printed on the label applied to the enclosure. Information is listed in the delivery document too. Please always quote the order code and the serial number when reaching Lika Electronic for purchasing spare parts or needing assistance. For any information on the technical characteristics of the product refer to the technical catalogue.



Warning: encoders having order code ending with "/Sxxx" may have mechanical and electrical characteristics different from standard and be supplied with additional documentation for special connections (Technical Info).

3 - Mechanical installation

3.1 IX58 encoder overall dimensions

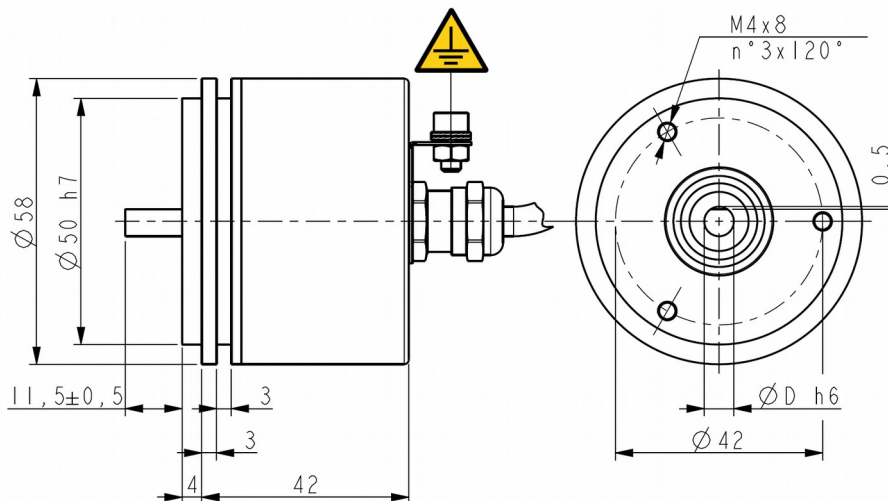

3.2 IX58S encoder overall dimensions

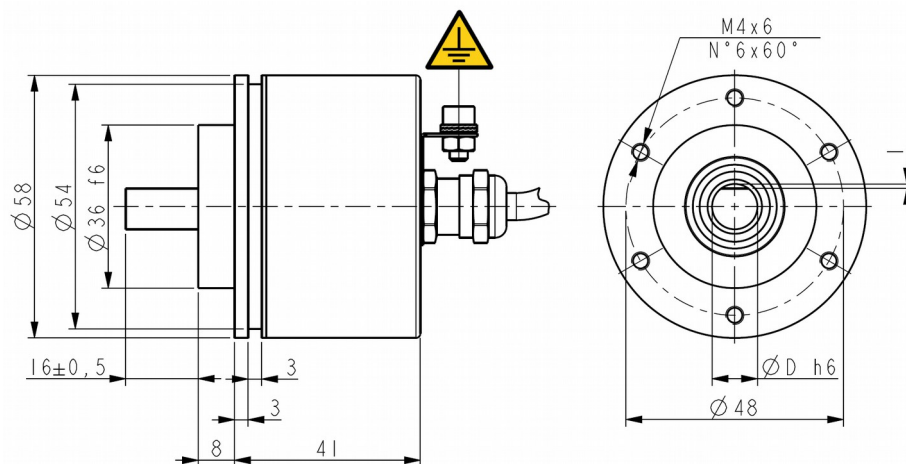

3.3 CX58 encoder overall dimensions

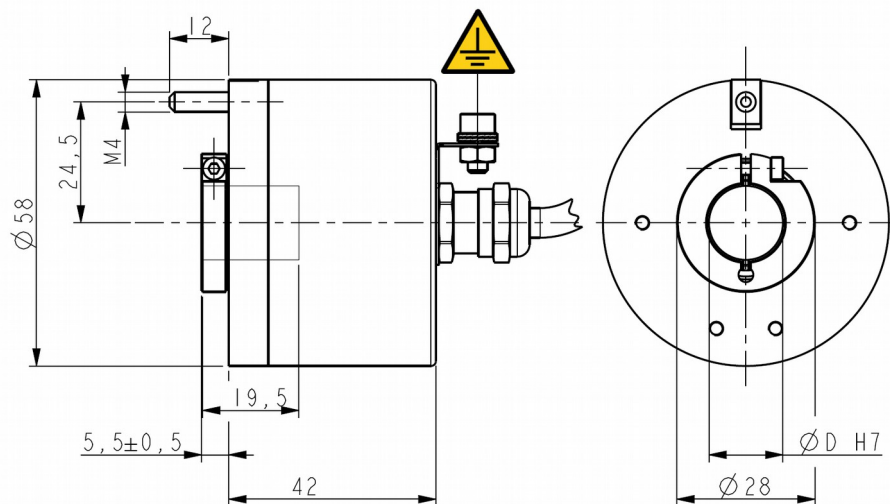

3.4 CX59 encoder overall dimensions

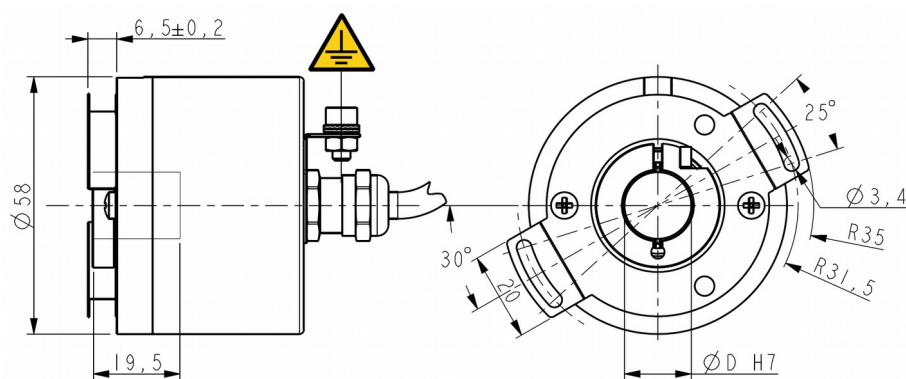

3.5 Mounting instructions



WARNING

Installation must be carried out by qualified personnel only, with power supply disconnected and mechanical parts compulsorily in stop.

Do not force the rotation of the shaft manually, it could cause irreparable damage!

For further information please refer also to the "1 - Safety summary" section on page 17 and the "5 - Certificates" section on page 27.

3.5.1 IX58 and IX58S encoders with solid shaft

- Mount the flexible coupling **1** on the encoder shaft;
- fix the encoder to the flange **2** (or to the mounting bell) by means of the M4 screws **3**;
- secure the flange **2** to the support (or the mounting bell to the motor);
- mount the flexible coupling **1** on the motor shaft;
- make sure the misalignment tolerances of the flexible coupling **1** are respected.

3.5.1.1 Standard installation- IX58 and IX58S

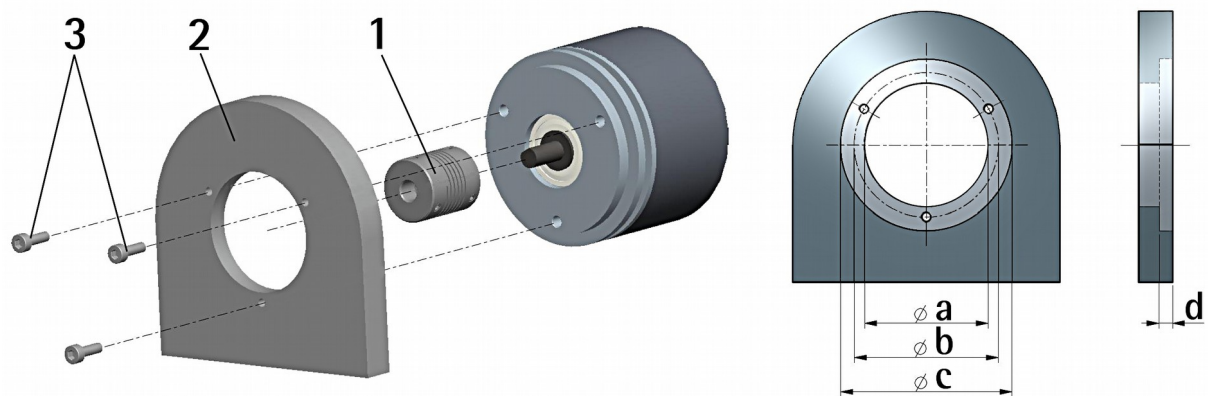

	a [mm]	b [mm]	c [mm]	d [mm]
IX58	-	42	50 F7	4
IX58S	36 H7	48	-	-

3.5.1.2 Installation using fixing clamps (LKM-386 order code) – IX58 and IX58S

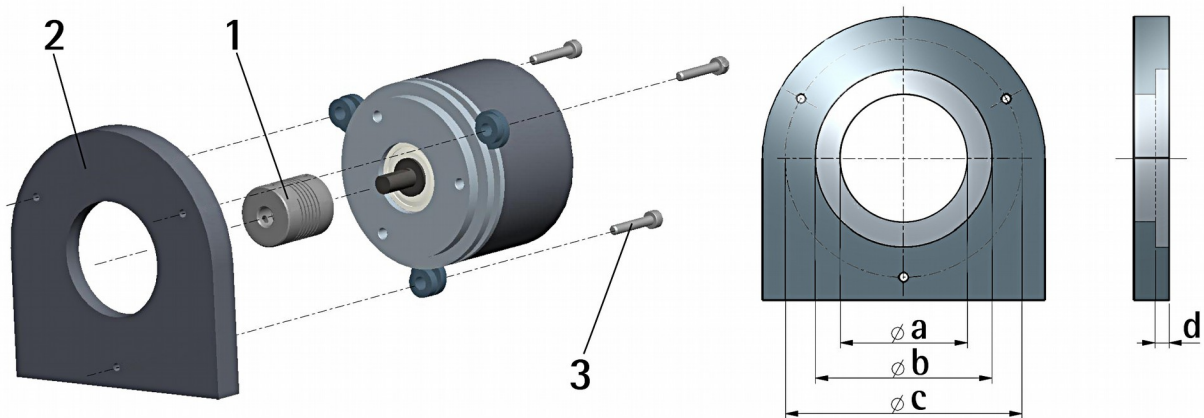

	a [mm]	b [mm]	c [mm]	d [mm]
IX58	-	50 F7	67	4
IX58S	36 H7	-	67	-

3.5.1.3 Installation using a mounting bell (PF4256 order code) – IX58S

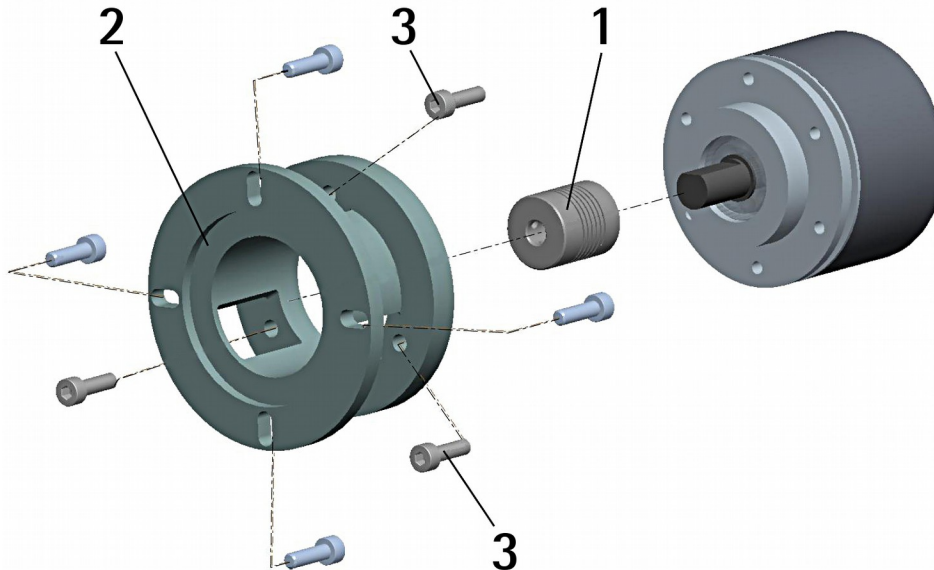

NOTE

In order to guarantee reliability over time of the encoder mechanical parts, we recommend a flexible coupling to be installed between the encoder and the motor shaft. Make sure the misalignment tolerances of the flexible coupling are respected.

3.5.2 CX58 and CX59 encoders with hollow shaft

3.5.2.1 CX58 installation using the anti-rotation pin

- Fasten the anti-rotation pin **1** to the rear of the motor (secure it using a locknut);
- mount the encoder on the motor shaft using the BR1 reducing sleeve **8** (if supplied); avoid forcing the encoder shaft;
- insert the anti-rotation pin **1** into the slot on the flange of the encoder; this secures it in place by grub screw **2**, preset at Lika;
- fix the collar **3** to the encoder shaft (add some threadlocker to fix the screw).

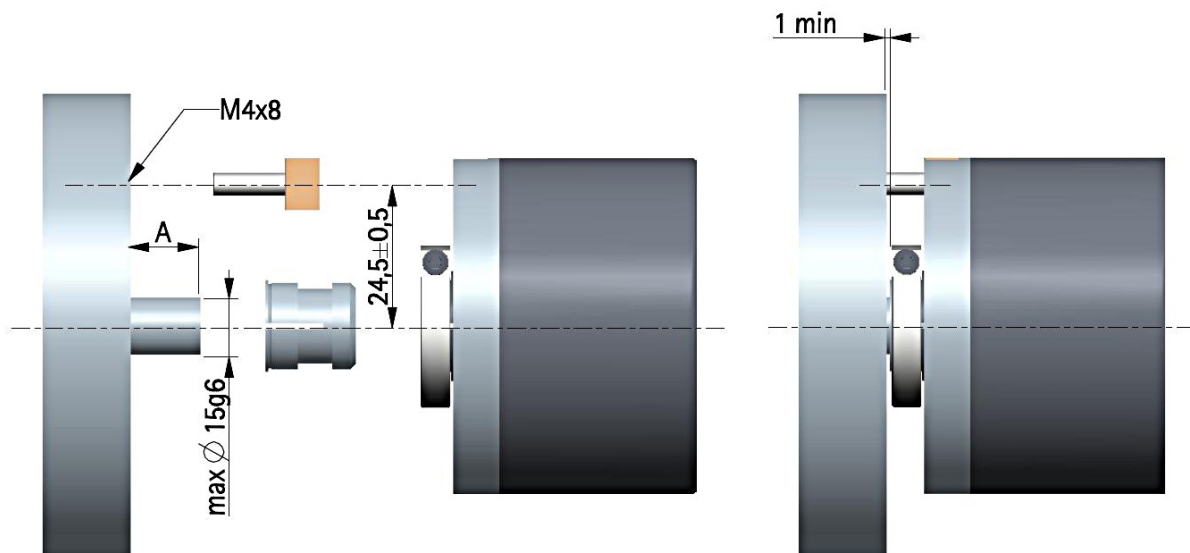
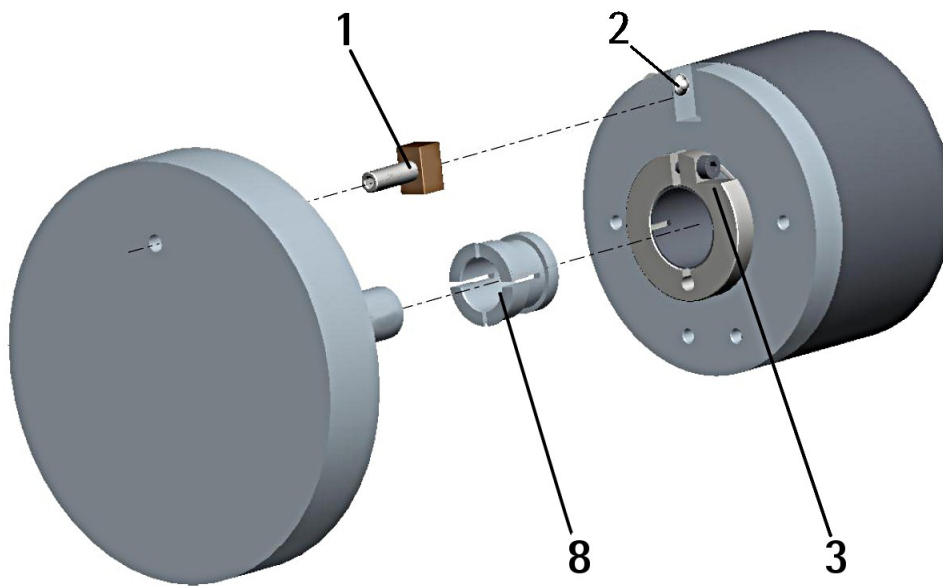

A: min. 8 mm, max. 18 mm

3.5.2.2 CX59 installation using the fixing plate

- Remove the anti-rotation pin **1** (see the information in the previous page);
- mount the encoder on the motor shaft using the BR1 reducing sleeve **8** (if supplied); avoid forcing the encoder shaft;
- fasten the fixing plate **4** to the rear of the motor using two M3 cylindrical head screws **5**;
- fix the collar **3** to the encoder shaft (add some threadlocker to fix the screw).

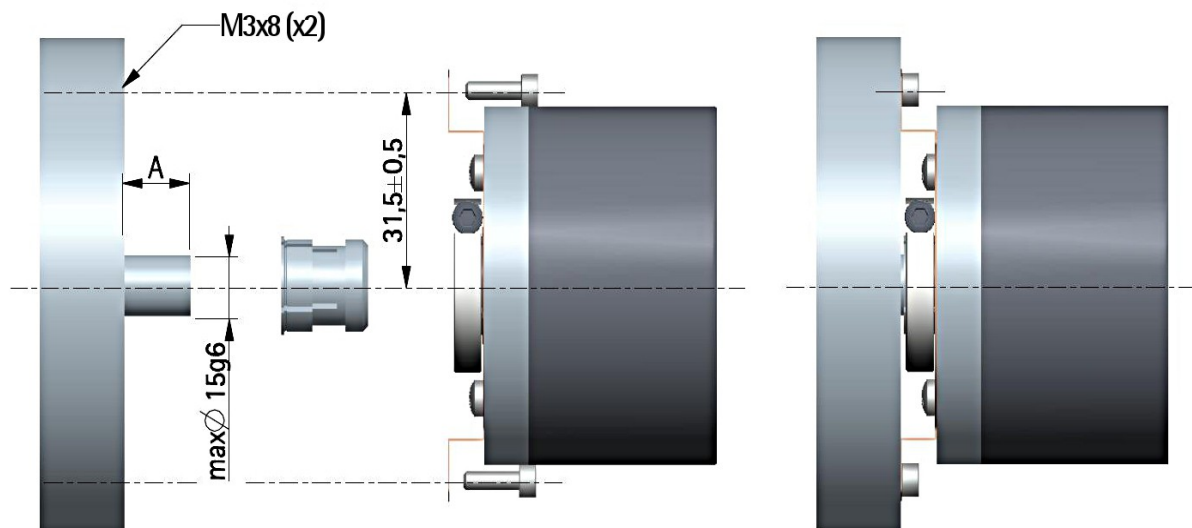
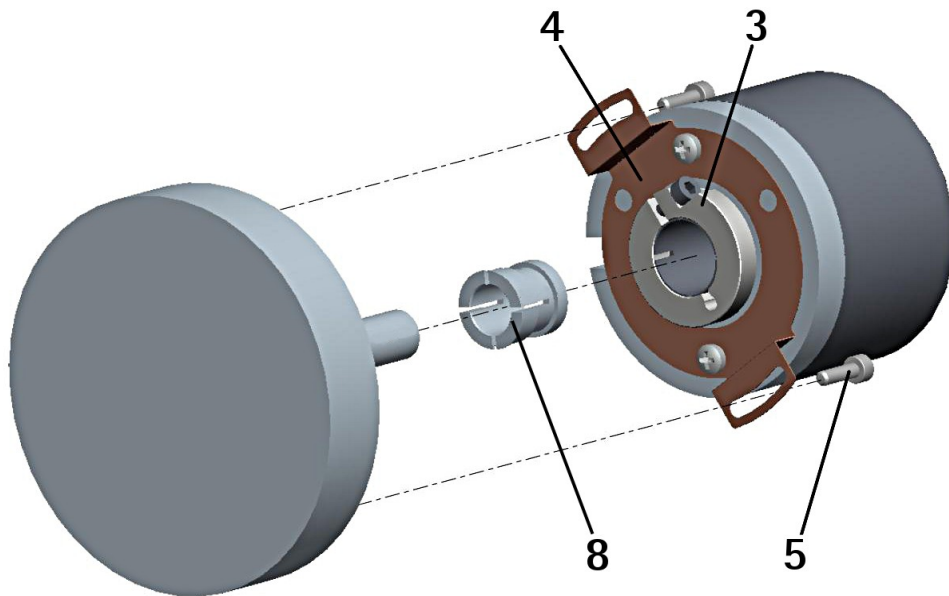

A: min. 8 mm, max. 18 mm



NOTE

You are strongly advised not to carry out any mechanical operations (drilling, milling, etc.) on the encoder shaft. This could cause serious damages to the internal parts and result in immediate loss of warranty. Please contact our technical personnel for the complete availability of "custom made" shafts.

4 - Electrical connections



WARNING

In classified areas the electrical connection of the device must be carried out in compliance with the methods stated in the EN 60079-0 regulation. The rated supply voltage must not exceed 30Vdc. The user has to take suitable measures in order to prevent longer or continuous disturbances that cause the supply voltage to exceed by 10% or more. For further information please refer also to the "1 - Safety summary" section on page 17 and the "5 - Certificates" section on page 27.



WARNING

Turn off the power supply before connecting the device.



WARNING

If wires of unused signals come in contact, irreparable damage could be caused to the device. Thus they must be cut at different lengths and insulated singularly.

4.1 Connection to ground

Use the connection point provided in the encoder's enclosure (see the Figures on page 19 ff) to connect the unit to ground. Fix the ground cable to the connection point by means of a ring crimp terminal and a M4 bolt. The connection point to ground might be provided also on the installation side by connecting the cable shield to the earth point. It is user's duty to find the best solution to minimize the interference. Please make sure that ground is not affected by noise.

4.2 IX58-/CX58-...ZNF...

N, P, Y, L, H output circuits



Function	I5 type cable
A	Brown
B	Blue
0	White
+Vdc power supply	Red
0Vdc power supply	Black
Shielding	Shield

* See the order code for power supply voltage level



EXAMPLE

IX58-L-4096ZNF1... +Vdc = +5Vdc ± 5%

IX58-H-4096ZNF4... +Vdc = +5Vdc +30Vdc

4.2.1 I5 cable specifications

Model : LIKA encoder cable type I5
 Wires : 5 x 0.22 mm² (24/7 AWG)
 Jacket : flame retardant PVC
 Shield : aluminium/polyester foil, coverage > 120% and flexible tinned copper drain wire 24/7 AWG
 External diameter : 4.5 mm ± 0.1 mm
 Minimum bend radius : external diameter x 10 min.
 Operating temperature : -20°C +80°C
 Conductor resistance : < 90 Ω/km

4.3 IX58-/CX58-...ZCU...

N, P, Y, L, H, V output circuits

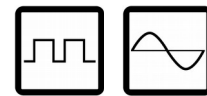

Function	I8 type cable
A	Yellow
/A	Blue
B	Green
/B	Orange
0	White
/0	Grey
+Vdc power supply	Red
0Vdc power supply	Black
Shielding	Shield

* See the order code for power supply voltage level



EXAMPLE

IX58-L-4096ZCU1... +Vdc = +5Vdc ± 5%
 IX58-H-4096ZCU4... +Vdc = +5Vdc +30Vdc

4.3.1 I8 cable specifications

Model : LIKA encoder cable type I8
 Wires : 8 x 0.22 mm² (24/7 AWG)
 Jacket : flame retardant PVC
 Shield : aluminium/polyester foil, coverage > 120% and flexible tinned copper drain wire 24/7 AWG
 External diameter : 5.1 mm ± 0.1 mm
 Minimum bend radius : external diameter x 10 min.
 Operating temperature : -20°C +80°C
 Conductor resistance : < 90 Ω/km

5 – Certificates

5.1 Declaration of ATEX Conformity



Lika Electronic Srl
Via S. Lorenzo, 25
36010 Carrè (VI) • Italy

Smart encoders & actuators

Carre', 31.08.2015

Declaration of Conformity

The manufacturer:
LIKA ELECTRONIC SRL
Via S. Lorenzo, 25
36010 Carrè (VI) – Italy

hereby declares that the following products:

Lika encoder series IX58, IX58S, CX58, CX59

with the marking:

Ex II 3G Ex nA IIB T5 Gc
EX II 3D Ex tc IIIC T100° Dc IP65

may be used in Zone 2 and Zone 22 hazardous areas.

Gas explosion protected equipment for Zone 2, according to EN60079-15
Zone 2 includes areas in which an explosive atmosphere consisting of a mixture with air of flammable substances in the form of gas or vapour is not likely to occur in normal operation but, if it does occur, will persist for a short period only.

Dust explosion protected equipment for Zone 22, according to EN60079-31
Zone 22 includes areas in which an explosive atmosphere in the form of a cloud of dust in air is not likely to occur in normal operation but, if it does occur, will persist for a short period only.

Lika Electronic Srl
Smart encoders & actuators



Headquarters & Plant
Via S. Lorenzo, 25
36010 Carrè (VI) • Italy

Tel. +39 0445 806600
Fax +39 0445 806699
info@lika.biz • www.lika.biz

P.I./C.F. IT 00817760242
VAT # IT 00817760242
R.E.A. 165423/Vicenza



Lika Electronic Srl
Via S. Lorenzo, 25
36010 Carrè (VI) • Italy

Smart encoders & actuators

Protection requirements:

Zone 22, dust explosion protection (D)

Protection by means of the housing: the construction of the product protects against the penetration of dust in hazardous quantities (min. IP5x) and guarantees that the surface temperature is under the ignition temperature of dust/air mixtures as well as under the smouldering temperature of dust deposits.

Zone 2, gas explosion protection (G)

Protection by non sparking equipment: the construction minimizes the occurrence of sparks, arcs or hot surfaces, which in normal operation might give the risk of explosion.

The manufacturer's specification of the purchased product such as operating temperature, shaft rotational speed, shaft load, max. supply voltage, etc must under no circumstances be exceeded.

Protection requirements for rotary encoders of category 3GD:

- The product must be correctly assembled (encoder body and connection cap)
- The degree of protection in the installs condition must be at least IP6x.
- The maximum surface temperature (in °C) of the product must not exceed 2/3 of the ignition temperature of the dust/air mixture.
- During normal operation no sparks, arcs and non-permissible temperatures should occur.
- The upper continuous operating temperature of plastic parts must be 10°C higher the maximum temperature that can arise at the hottest point of the product, based on the highest environmental temperature possible in service.

Obligations of the user:

- The rated supply voltage must not exceed 30Vdc.
- The manufacturer's specification concerning the operating temperature range (see product data sheet) has to be fully observed.
- The product must be protected against overheating due to mechanical or electrical overloading.
- The user has to take suitable measures in order to prevent longer or continuous disturbances that cause the supply voltage to exceeded by 10% or more.
- The user has the obligation to protect in an appropriate way the area where electrical connections are carried out (make sure the product is not connected to power supply when connecting) and ensure that this area also complies with Zone 2/22 requirements.
- The listed products do not meet the "impact test" requirements of EN60079-0, section 26.4.2. but can however be used in Zone 2/22 areas where the user ensures that impacts are avoided by appropriate protection.

LIKA Electronic SRL



Marco CALABRESE
Managing Director

Lika Electronic Srl
Smart encoders & actuators



Headquarters & Plant
Via S. Lorenzo, 25
36010 Carrè (VI) • Italy

Tel. +39 0445 806600
Fax +39 0445 806699
info@lika.biz • www.lika.biz

P.I./C.F. IT 00817760242
VAT # IT 00817760242
R.E.A. 165423/Vicenza

5.3 Safety instructions

**SAFETY INSTRUCTIONS encoders series
IX58, IX58S, CX58, CX59**

1) Marking:

II3 GD, Ex nA IIB T5 Gc, Ex tc IIIC T100° Dc, IP65

Explosion-proof encoder manufactured according to the following regulations:

EN 60079-0
EN 60079-31
EN 61000-6-4, EN 61000-6-2
EN 60079-15

- **Ex:** Equipment for use in potentially explosive atmospheres
- **d:** Protection by explosion-proof housing
- **IIB:** Electrical apparatus for use in potentially explosive atmospheres other than mines susceptible to firedamp.
- **T5:** Maximum housing surface temperature 100°C
- **Gc:** Level of protection (EPL). The equipment can be used in Zone 2.
- **tc:** Electrical apparatus with protective housing for use in the presence of combustible dust.
- **IIIC:** Equipment or protective housing intended for use in potentially explosive atmospheres with presence of combustible dust.
- **T100°C:** Maximum surface temperature.
- **Dc:** Level of protection (EPL). The equipment can be used in Zone 22.
- **IP65:** Degree of IP protection for dust-proof housing.

Equipment intended for use in the following Zones:

Zone 2: Mixture of gas/air, vapour/air, mist/air,

Zone 22: Mixture of dust/air

ATTENTION: Equipment not to be used in Zone 0, 1 and 21

- 2) The equipment has to be installed only by qualified personnel and according to the applicable regulations.
- 3) Do not tool or drill the equipment
- 4) Do not open the equipment
- 5) Do not loosen or unscrew the cable-press
- 6) Use the encoder's fixing pin or plate (CX58, CX59) for installation and against rotation
- 7) Protect the device against shock and mechanical damages
- 8) Use the product according to the indicated degree of IP protection
- 9) Maximum permissible environmental temperature +70°C (at continuous rotational speed of max. 6000 rpm)
- 10) In classified areas the electrical connection of the device has to be carried out according to the methods of EN 60079-0.
- 11) Connect the device according to the electrical connections scheme on the user manual
- 12) Provide a ground connection (GND) using the ground screw on the housing

LIKA ELECTRONIC SRL
Carrè', 31.08.2015

Document release	Release date	Description	HW	SW	Interface
1.0	22.09.2015	1 st issue			
1.1	29.07.2016	EU Declaration of Conformity update, electromagnetic compatibility norm update			



Dispose separately

lika

Lika Electronic

Via S. Lorenzo, 25 • 36010 Carrè (VI) • Italy

Tel. +39 0445 806600

Fax +39 0445 806699



info@lika.biz • www.lika.biz