SAFETY MODULE NA12D



User manual

CARLO GAVAZZI

CE

Index

1. INTRODUCTION	3
2. FUNCTION	3
3. INSTALLATION	3
3.1 <i>Warning</i>	3
3.2 <i>Wiring</i>	3
3.3 <i>Power supply</i>	3
3.4 <i>Input</i>	4
3.5 <i>START Circuit</i>	4
3.6 <i>Safety Outputs</i>	4
4. OPERATING MODE	5
5. TEST & ACTIVATION	5
6. USAGE PRECAUTIONS	6
7. INSPECTIONS AND MAINTENANCE	6
8. APPLICATIONS	6
9. TECHNICAL DATA	7

1. INTRODUCTION

This user manual must be read and completely understood, prior to carrying out any operation on the module, by personnel dealing with all the activities of the **NA12D** safety module. The instructions refer to the models configured either for controlled manual START or for not-controlled manual/automatic START.

All the operations described in this manual must be carried out exclusively by specialised personnel by carefully following all the indications given.

The user decides under his complete responsibility that the safety module is suited for the application.

2. FUNCTION

The safety module **NA12D** can be employed in safety circuits to control E-STOP pushbutton and limit switch devices, according to 98/37/CE Machinery Directive.

3. INSTALLATION

3.1 Warning

- The **NA12D** safety module must be installed following the standards in force in the country of use, when the machine is not powered and with no dangers for the operator, on the machine's electrical board in a dry and clean place (minimum protection degree: IP54), fixed on the spe-

cial DIN rail.

- If the safety module is tampered, it can not ensure the safety of the operator any more and the warranty is void.
- To avoid interference due to coupling, run the limit switches connecting conductors separately from the power conductors.
- Avoid installation during storms.
- Do not dispose of the packaging in the environment.

3.2 Wiring

It is recommended to use conductors with section and length adequate to the terminals, currents and distances involved, ensuring that the conductors are not excessively tight, that their positioning avoids potential cuts or squashing and that they are not in the way of people or things.

3.3 Power supply

Connect the A1 and A2 terminals to the power supply source.

TERM.	CONNECTION
A1	+24VDC / 24VAC
A2	GND / 24 VAC
S11-S12 S21-S22	N.O. Input channels
X-1-X2	Feedback loop and START terminals
13-14 23-24	N.O. Safety outputs

Tab. 1: Terminal description

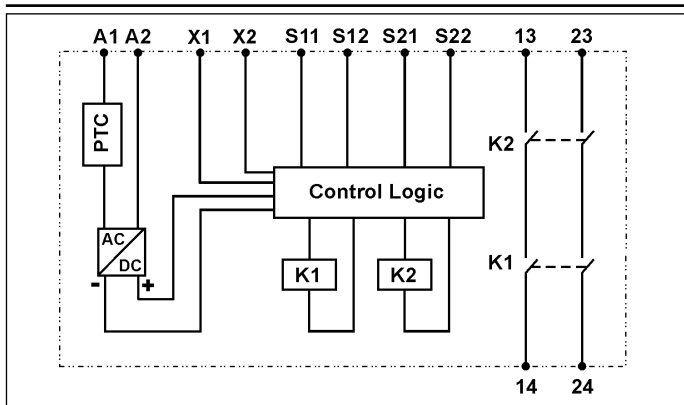

Fig. 1 - **NA12D** diagram

3.4 Input

Connect the first N.O. input device/contact to the S11-S12 terminals, and the second one to the S21-S22 terminals.

The **NA12D** must be connected to two N.O. switches/contacts S1 and S2, which are operated (contact closed) when the E-STOP is not pushed or when the gate/door is closed (no dangerous situations for the operator).

The safety relay is enabled to close the safety outputs only if both S1 and S2 are operated.

3.5 START Circuit

The base version of the safety module is set up with notcontrolled automatic/manual START. Also the version with monitored manual START is available. The

first model can be employed connecting between the X1-X2 terminals either a N.O. START pushbutton (for not monitored manual START) or a short-circuit (for automatic START); the second one can be employed only connecting between the X1-X2 terminals a N.O. START pushbutton, whose integrity is monitored by the module.

3.6 Safety Outputs

Two N.O. voltage free safety outputs are available between the 13-14 and 23-24 terminals: their contacts are closed when the safety module is correctly powered, the input switches are operated, and the START circuit has been activated, as described in this user manual.

4. OPERATING MODE

With manual START configuration, the safety outputs close, if S1 & S2 are operated, when the N.O. START pushbutton is pushed. With Automatic START configuration, the safety outputs close as soon as both S1 & S2 switches are operated. The Channel 1 & Channel 2 LED turn on.

Opening even one input contact (S1 and/or S2) leads to a safety condition for the operator, forcing immediately the safety outputs to an open status. The LED relative to the channel whose input has been opened turns off.

A new operating cycle is possible only after opening both input contacts and then closing them (and pushing the START button, if the safety module has been set up with Manual START configuration). In the model with monitored manual START set up, if the N.O. START button gets welded, the safety outputs cannot close their contacts any more.

5. TEST & ACTIVATION

The following operations must be repeated when the module is installed and every time the wiring is changed and at regular intervals by carrying out *in sequence all* the steps described below without any type of dangerous condition for the operators.

STEP 1 Check the integrity, the correct installation, the correct positioning on the machine and the correct functioning of all the devices connected to the inputs and to the outputs of the **NA12D** safety module. Check also the correct wiring of all the devices (See 3.2).

STEP 2 Power on the safety module: the **POWER** LED turns on (this LED has to be considered ON in all the steps of this sequence). The **CHANNEL1** and **CHANNEL2** are off.

Close the input contacts: the safety outputs are open and the **CHANNEL1** & **CHANNEL2** are off (if the module is configured for automatic START, **CHANNEL1** & **CHANNEL2** turns on and the safety outputs close).

Close the START contact: the safety outputs close and the **CHANNEL1**, **CHANNEL2** LED turn on.

STEP 3 Open both input contacts: the safety outputs open and the **CHANNEL1**, **CHANNEL2** LED turn off.

During **STEP 2** check that the safety outputs do not close - with manual START configuration - simply closing both input contacts, without closing the START pushbutton.

STEP 4 (This step must operate first on one input contact, then on the other one) Repeat the procedure from **STEP 2**, opening and then closing only one input contact and checking that the safety outputs do not close (with automatic START and with manual START).

The **STEPS 3** and **4** must be repeated for each input device connected to the input terminals.

6. USAGE PRECAUTIONS

The safety module can check the integrity of external contactors or expansion modules simply connecting their N.C. control contacts in series to the START contact (or to the bridge, in automatic START configuration) between X1-X2 terminals.

It is recommended to connect a fuse in series to the safety outputs to reduce the risk of the safety outputs contacts welding (see outputs technical data).

Never, in any situation, connect spark quenching unit circuits in parallel to safety outputs contacts: the safety function would no longer be guaranteed.

Never, in any circumstance, exceed the electrical ratings stated in the technical data table of this manual.

7. INSPECTIONS AND MAINTENANCE

The integrity of the safety module and of all the connected devices must be checked regularly according to the risk evaluation of the plant, under the complete responsibility of the user. Regular inspections must be performed repeating *all the operations* listed in the **TEST & ACTIVATION** section.

The safety module doesn't require internal maintenance: it must be periodically cleaned - with plant powered off - together with all the connected devices, removing dust, liquids and condensation.

8. APPLICATION

In Figure 2, if S1 & S2 are both operated, the safety outputs close (with automatic START) or are enabled to close (with manual START).

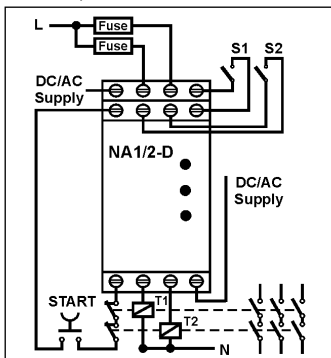

9. TECHNICAL DATA

ELECTRICAL CHARACTERISTICS	
Power supply voltage	24 Vac -15/+10% 50 ÷ 60Hz, 24 Vdc -15/+10%
Current consumption	70 mA (@ 24Vdc, without load)
Power consumption	max 5 VA
Input	2 N.O. Voltage-free
Safety Category (EN 954-1)	4
E-STOP Category (EN 60204-1)	0
Short-Circuit Protection	Internal PTC
SAFETY OUTPUTS	
Function	Force-guided N.O. contacts
Max Switching Voltage	AC 230/240 V; DC 300 V
Max. Switching Current	6 A
Max. Switching Power (Resistive Load)	1380 VA
Output contacts protection	External fuse: 4 A delayed / 5A fast
Mechanical Life	> 10 ⁷ switching cycles
Electrical Life (with max. load)	> 10 ⁵ switching cycles
TIMINGS	
Response time (from input open to outputs open)	Max. 30 ms
START procedure delay (from START button pushed to safety outputs closed)	Max. 150 ms
Contemporaneity - in closing - between the two input channels	Infinite
LED WARNINGS	
POWER	ON : Module supplied OFF : Module not supplied
CHANNEL1 & CHANNEL2	ON : Safety outputs closed OFF : Safety outputs open

MECHANICAL AND ENVIRONMENTAL CHARACTERISTICS

Housing	PA 6.6 flammability class VO-UL94
Connection Terminals	12 screw terminals in PA 6.6 flammability class VO-UL94
Fixing	OMEGA-DIN EN50022 Rail
Protection degree of the module	IP30
Minimum Protection degree of the installation location	IP54
EMC compatibility	EN 61000-6-2; EN 61000-6-3
Operating temperature	-20 ÷ 65°C
Storage Temperature	-25 ÷ 65°C
Relative operating humidity	10 ÷ 95%
Relative storage humidity	10 ÷ 95%
Cross-Section of the cables to connect to the terminals	0.14 ÷ 2.5 mm ² (rigid & flexible)
Torque setting on connection terminals	0.5 Nm
Dimensions	99 x 22.5 x 115 mm
Weight	200g



CARLO GAVAZZI si riserva il diritto di apportare modifiche o miglioramenti senza preavviso
CARLO GAVAZZI reserves the right to make improvements or changes without prior notice