

# Distribution Dry-Type Transformers—Low Voltage

## Contents

### Distribution Dry-Type Transformers—Low Voltage

Glossary of Transformer Terms . . . . .	19.0-2
The Energy Policy Act of 2005 . . . . .	19.0-5
General Description/Product Overview . . . . .	19.1-1
General Purpose Ventilated Transformers . . . . .	19.1-4
General Purpose Encapsulated . . . . .	19.1-7
K-Factor Rated for Nonlinear Loads (KT Type) . . . . .	19.1-10
Harmonic Mitigating (HMT Type) . . . . .	19.1-12
Motor Drive Isolation . . . . .	19.1-15
Hazardous Location . . . . .	19.1-16
Mini-Power Centers . . . . .	19.1-17
FAQ . . . . .	19.1-36

### Specifications

See Eaton's *Product Specification Guide*, available on CD or on the Web.

CSI Format: . . . . .	1995	2010
Dry-Type Transformers . . . . .	16461	26 22 13
Mini-Power Centers . . . . .	16463	26 27 00.11

### Further Information

*Volume 2—Commercial Distribution* 2011, Tab 9 . . . . . CA08100003E



*Eaton's Family of Dry-Type Distribution Transformers*

## Glossary of Transformer Terms

**Air cooled:** A transformer that is cooled by the natural circulation of air around, or through, the core and coils.

**Ambient noise level:** The existing or inherent sound level of the area surrounding the transformer, prior to energizing the transformer. Measured in decibels.

**Ambient temperature:** The temperature of the air surrounding the transformer into which the heat of the transformer is dissipated.

**Ampacity:** The current-carrying capacity of an electrical conductor under stated thermal conditions. Expressed in amperes.

**Ampere:** The practical unit of electric current.

**Attenuation:** A decrease in signal power or voltage. Unit of measure is dB.

**Autotransformer:** A transformer in which part of the winding is common to both the primary and the secondary circuits.

**Banked:** Two or more single-phase transformers wired together to supply a three-phase load. Three single-phase transformers can be “banked” together to support a three-phase load. For example, three 10 kVA single-phase transformers “banked” together will have a 30 kVA three-phase capacity.

**BIL:** Basic impulse level. The ability of a transformer’s insulation system to withstand high voltage surges. All Eaton 600 V-class transformers have a 10 kV BIL rating.

**BTU:** British thermal unit. In North America, the term “BTU” is used to describe the heat value (energy content) of fuels, and also to describe the power of heating and cooling systems, such as furnaces, stoves, barbecue grills and air conditioners. When used as a unit of power, BTU “per hour” (BTU/h) is understood, though this is often abbreviated to just “BTU.”

**Buck-Boost:** The name of a standard, single-phase, two-winding transformer application with the low-voltage secondary windings connected as an autotransformer for boosting (increasing) or bucking (decreasing) voltages in small amounts. Applications can either be single-phase or three-phase.

**CE:** Mark to indicate third-party approved or self-certification to specific requirements of the European community.

**Celsius (centigrade):** Metric temperature measure.

$$^{\circ}\text{F} = (1.8 \times ^{\circ}\text{C}) + 32$$

$$^{\circ}\text{C} = (^{\circ}\text{F} - 32) / 1.8$$

**Center tap:** A reduced capacity tap at the mid-point of a winding. The center tap on three-phase delta-delta transformers is called a lighting tap. It provides 5% of the transformer’s kVA for single-phase loads.

**Certified tests:** Actual values taken during production tests and certified as applying to a given unit shipped on a specific order. Certified tests are serial number-specific.

**Common mode:** Electrical noise or voltage fluctuation that occurs between all of the line leads and the common ground, or between ground and line or neutral.

**Compensated transformer:** A transformer with a turns ratio that provides a higher than nameplate output (secondary) voltage at no load, and nameplate output (secondary) voltage at rated load. It is common for small transformers (2 kVA and less) to be compensated.

**Conductor losses:** Losses (expressed in watts) in a transformer that are incidental to carrying a load: coil resistance, stray loss due to stray fluxes in the windings, core clamps, and the like, as well as circulating currents (if any) in parallel windings. Also called load losses.

**Continuous duty rating:** The load that a transformer can handle indefinitely without exceeding its specified temperature rise.

**Core losses:** Losses (expressed in watts) caused by magnetization of the core and its resistance to magnetic flux. Also called no-load losses or excitation losses. Core losses are always present when the transformer is energized.

**CSA:** Canadian Standards Association. The Canadian equivalent of Underwriters Laboratories (UL).

**CSL3:** Candidate Standard Level 3 (CSL3) design criteria developed by the U.S. Department of Energy.

**cUL:** Mark to indicate UL Certification to specific CSA Standards.

**Decibel (dB):** Unit of measure used to express the magnitude of a change in signal or sound level.

**Delta connection:** A standard three-phase connection with the ends of each phase winding connected in series to form a closed loop with each phase 120 degrees from the other. Sometimes referred to as three-wire.

**Dielectric tests:** Tests that consist of the application of a voltage higher than the rated voltage for a specified time for the purpose of determining the adequacy against breakdowns of insulating materials and spacings under normal conditions.

**DOE 2016 efficient:** A revision to federal law 10 CFR Part 431 (2007) that mandates higher efficiency for distribution transformers manufactured for sale in the U.S. and U.S. Territories effective January 1, 2016. “TP-1” efficient transformers can no longer legally be manufactured for use in the U.S. as of this date.

**Dry-type transformer:** A transformer in which the core and coils are in a gaseous or dry compound insulating medium. A transformer that is cooled by a medium other than a liquid, normally by the circulation of air.

**E3:** Eaton’s version of a CSL3 transformer.

**Eddy currents:** The currents that are induced in the body of a conducting mass by the time variation of magnetic flux or varying magnetic field.

**Efficiency:** The ratio of the power output from a transformer to the total power input. Typically expressed as a %.

**Electrostatic shield:** Copper or other conducting sheet placed between primary and secondary windings, and grounded to reduce electrical interference and to provide additional protection from line-to-line or line-to-ground noise. Commonly referred to as “Faraday shield.”

**Encapsulated transformer:** A transformer with its coils either dipped or cast in an epoxy resin or other encapsulating substance.

**Enclosure:** A surrounding case or housing used to protect the contained equipment against external conditions and prevent personnel from accidentally contacting live parts.

**Environmentally preferable product:** A product that has a lesser or reduced negative effect on human health and the environment when compared to competing products that serve the same purpose. This comparison may consider raw materials acquisition, production, manufacturing, packaging, distribution, reuse, operation, maintenance and disposal of the product. This term includes recyclable products, recycled products and reusable products.

**EPACT:** The Energy Policy Act of 1992 (EPACT) is an important piece of legislation for efficiency because it established minimum efficiency levels for dry-type distribution transformers manufactured or imported after December 2006. EPACT, which was based on NEMA standards, defined a number of terms, including what constitutes an energy-efficient transformer. The DOE issued a rule that defines these transformers and how manufacturers must comply. In April 2013, the DOE mandated even higher minimum efficiency levels for distribution transformers effective starting in January 2016. DOE EPACT rule (PDF): Energy Efficiency Program for Certain Commercial and Industrial Equipment: Test Procedures, Labeling, and the Certification Requirements for Electric Motors. Final Rule. 10-CFR Part 431.

**Excitation current:** No load current. The current that flows in any winding used to excite the transformer when all other windings are open-circuited. It is usually expressed in percent of the rated current of a winding in which it is measured. Also called magnetizing current.

**FCAN:** “Full Capacity Above Nominal” taps. Designates the transformer will deliver its rated kVA when connected to a voltage source which is higher than the rated primary voltage.

**FCBN:** “Full Capacity Below Nominal” taps. Designates the transformer will deliver its rated kVA when connected to a voltage source which is lower than the rated primary voltage.

**Frequency:** On AC circuits, designates the number of times that polarity alternates from positive to negative and back again per second, such as 60 cycles per second. Typically measured in Hertz (Hz).

**Ground:** Connecting one side of a circuit to the earth through low resistance or low impedance paths to help prevent transmitting electrical shock to personnel.

**Harmonic:** A sinusoidal waveform with a frequency that is an integral multiple of the fundamental frequency (60 Hz).

60 H<sub>3</sub> fundamental  
120 H<sub>3</sub> 2nd harmonic  
180 H<sub>3</sub> 3rd harmonic  
240 H<sub>3</sub> 4th harmonic

**Harmonic distortion:** Nonlinear distortion of a system characterized by the appearance of harmonic (non-sinusoidal) currents in the output, when the input is sinusoidal.

**Harmonic distortion, total (THD):** The square root of the sum of the squares of all harmonic currents present in a load, excluding the fundamental 60 Hz current. Usually expressed as a percent of the fundamental.

**High-voltage windings:** In a two-winding transformer, the winding intended to have the greater voltage. Usually marked with “H” designations.

**HMT:** Harmonic Mitigating Transformer (HMT) is better able to handle the harmonic currents present in today’s electrical power system, thereby increasing system capacity, reducing distortion throughout a facility, help to minimize downtime and “mysterious” maintenance on equipment, and return the longevity of equipment life through reduced operational energy losses, thereby running cooler.

**Hp:** Horsepower. The energy required to raise 33,000 pounds a distance of one foot in one minute. 1 hp is equal to 746 watts, or 0.746 kW.

**Hi pot:** A standard test on dry-type transformers consisting of extra-high potentials (voltages) connected to the windings. Used to check the integrity of insulation materials and clearances.

**Hottest-spot temperature:** The highest temperature inside the transformer winding. Is greater than the measured average temperature of the coil conductors, when using the resistance change method.

**Hysteresis:** The tendency of a magnetic substance to persist in any state of magnetization.

**Impedance:** The retarding forces of current in an AC circuit; the current-limiting characteristics of a transformer. Symbol = Z

**Inductance:** In electrical circuits, the opposition to a change in the flow of electrical current. Symbol = L

**Inducted potential test:** A standard dielectric test of transformer insulation. Verifies the integrity of insulating materials and electrical clearances.

**Inrush current:** The initial high peak of current that occurs in the first few cycles of energization, which can be 30 to 40 times the rated current.

**Insulating transformer:** Another term for an isolating transformer.

**Insulation:** Material with a high electrical resistance.

**Insulation materials:** Those materials used to insulate the transformer’s electrical windings from each other and ground.

**Integral TVSS or SPD:** Major standard change for surge protective devices (formerly known as transient voltage surge suppressors). The primary safety standard for transient voltage surge suppressors (TVSS) has undergone major revisions in the past three years with mandatory compliance by manufacturers required by September 29, 2009. Even the name of the standard has changed from UL Standard for Safety for Transient Voltage Surge Suppressors, UL 1449 to UL Standard for Safety for Surge Protective Devices, UL 1449. This means that TVSS listed to the UL 1449 2nd Edition standard will no longer be able to be manufactured after September 29, 2009. All Surge Protective Devices must be designed, tested, manufactured and listed to the UL 1449 3rd Edition standard after this date.

**Isolating transformer:** A transformer where the input (primary) windings are not connected to the output (secondary) windings (i.e., electrically isolated).

**K-factor:** A common industry term for the amount of harmonics produced by a given load. The larger the K-factor, the more harmonics that are present. Also used to define a transformer's ability to withstand the additional heating generated by harmonic currents.

**kVA:** Kilovolt-ampere. Designates the output that a transformer can deliver for a specified time at a rated secondary voltage and rated frequency without exceeding the specified temperature rise. When multiplied by the power factor, will give kilowatts or kW.

1000 VA = 1 kVA

**Lamination:** Thin sheets of electrical steel used to construct the core of a transformer.

**Limiting temperature:** The maximum temperature at which a component or material may be operated continuously with no sacrifice in normal life expectancy.

**Linear load:** A load where the current waveform conforms to that of the applied voltage, or a load where a change in current is directly proportional to a change in applied voltage.

**Live part:** Any component consisting of an electrically conductive material that can be energized under conditions of normal use.

**Load losses:** I<sup>2</sup>R losses in windings. Also see conductor losses.

**Low-voltage winding:** In a two-winding transformer, the winding intended to have the lesser voltage. Usually marked with "X" designations.

**Mid-tap:** See center tap.

**Noise level:** The relative intensity of sound, measured in decibels (dB). NEMA Standard ST-20 outlines the maximum allowable noise level for dry-type transformers.

**Nonlinear load:** A load where the current waveform does not conform to that of the applied voltage, or where a change in current is not proportional to a change in applied voltage.

**Non-ventilated transformer:**

A transformer where the core and coil assembly is mounted inside an enclosure with no openings for ventilation. Also referred to as totally enclosed non-ventilated (TENV).

**No load losses:** Losses in a transformer that is excited at rated voltage and frequency but that is not supplying a load. No load losses include core losses, dielectric losses and conductor losses in the winding due to the exciting current. Also referred to as excitation losses.

**Overload capability:** Short-term overload capacity is designed into transformers as required by ANSI. Continuous overload capacity is not deliberately designed into a transformer because the design objective is to be within the allowed winding temperature rise with nameplate loading.

**Percent IR (% resistance):** Voltage drop due to resistance at rated current in percent of rated voltage.

**Percent IX (% reactance):** Voltage drop due to reactance at rated current in percent of rated voltage.

**Percent IZ (% impedance):** Voltage drop due to impedance at rated current in percent of rated voltage.

**Phase:** Type of AC electrical circuit; usually single-phase two- or three-wire, or three-phase three- or four-wire.

**Polarity test:** A standard test on transformers to determine instantaneous direction of the voltages in the primary compared to the secondary.

**Primary taps:** Taps added to the primary (input) winding. See Tap.

**Primary voltage:** The input circuit voltage.

**Power factor:** The cosine of the phase angle between a voltage and a current.

**Ratio test:** A standard test of transformers to determine the ratio of the input (primary) voltage to the output (secondary) voltage.

**Reactance:** The effect of inductive and capacitive components of a circuit producing other than unity power factor.

**Reactor:** A single winding device with an air or iron core that produces a specific amount of inductive reactance into a circuit. Normally used to reduce of control current.

**Regulation:** Usually expressed as the percent change in output voltage when the load goes from full load to no load.

**Scott T connection:** Connection for three-phase transformers. Instead of using three sets of coils for a three-phase load, the transformer uses only two sets of coils.

**Series/multiple winding:** A winding consisting of two or more sections that can be connected for series operation or multiple (parallel) operation. Also called series-parallel winding.

**Short circuit:** A low resistance connection, usually accidental, across part of a circuit, resulting in excessive current flow.

**Sound levels:** All transformers make some sound mainly due to the vibration generated in its core by alternating flux. All Eaton general-purpose dry-type distribution transformers are designed with sound levels lower than NEMA ST-20 maximum levels.

**Star connection:** Same as a wye connection.

**Step-down transformer:** A transformer where the input voltage is greater than the output voltage.

**Step-up transformer:** A transformer where the input voltage is less than the output voltage.

**T-T connection:** See Scott T connection.

**Tap:** A connection brought out of a winding at some point between its extremities, usually to permit changing the voltage or current ratio. Taps are typically used to compensate for above or below rated input voltage, in order to provide the rated output voltage. See FCAN and FCBN.

**Temperature class:** The maximum temperature that the insulation system of a transformer can continuously withstand. The common insulation classes are 105, 150, 180 (also 185) and 220.

**Temperature rise:** The increase over ambient temperature of the windings due to energizing and loading the transformer.

**Total losses:** The sum of the no-load losses and load losses.

**Totally enclosed non-ventilated enclosure:** The core and coil assembly is installed inside an enclosure that has no ventilation to cool the transformer. The transformer relies on heat to radiate from the enclosure for cooling.

**Transformer tests:** Per NEMA ST-20, routine transformer production tests are performed on each transformer prior to shipment. These tests are: *Ratio tests* on the rated voltage connection; *Polarity and Phase Relation tests* on the rated connection; *No-Load and Excitation Current tests* at rated voltage on the rated voltage connection and *Applied Potential and Induced Potential tests*. Special tests include sound level testing.

**Transverse mode:** Electrical noise or voltage disturbance that occurs between phase and neutral, or from spurious signals across metallic hot line and the neutral conductor.

**Turns ratio:** The ratio of the number of turns in the high voltage winding to that in the low voltage winding.

**Typical test data:** Tests that were performed on similar units that were previously manufactured and tested.

**UL (Underwriters Laboratories):** An independent safety testing organization.

**Universal taps:** A combination of six primary voltage taps consisting of 2 at +2-1/2% FCAN and 4 at -2-1/2% FCBN.

**Watt:** A unit of electrical power when the current in a circuit is one ampere and the voltage is one volt.

**Wye connection:** A standard three-wire transformer connection with similar ends of single-phase coils connected together. The common point forms the electrical neutral point and may be grounded. Also referred to as three-phase four-wire. To obtain the line-to-neutral voltage, divide the line voltage by  $\sqrt{3}$  (1.732).

**The Energy Policy Act of 2005**

The Energy Policy Act of 2005 and the resulting federal law 10 CFR Part 431 (2007) require that efficiency of low-voltage dry-type distribution transformers manufactured between January 1, 2007 and December 31, 2015 shall be no less than the efficiency levels listed in Table 4-2 of NEMA Standard TP-1-2002. The U.S. Department of Energy passed a revision to 10 CFR Part 431 in 2013, mandating higher efficiency levels for distribution transformers manufactured starting January 1, 2016. Transformers manufactured starting on this date, for installation in the U.S., must meet the new efficiencies detailed in 10 CFR Part 431 (2016), commonly referred to as “DOE 2016 efficiency”. Transformers specifically excluded from the scope of this law include:

- Transformers rated less than 15 kVA
- Transformers with a primary or secondary voltage greater than 600 V
- Transformers rated for operation at other than 60 Hz
- Transformers with a tap range greater than 20%
- Motor drive isolation transformers
- Rectifier transformers
- Autotransformers
- Transformers that supply Uninterruptible Power Supplies
- Special impedance transformers
- Regulating transformers
- Sealed and non-ventilated transformers
- Machine tool transformers
- Welding transformers
- Grounding transformers
- Testing transformers
- Repaired transformers

**Table 19.0-1. Low-Voltage Dry-Type Distribution Transformer Efficiency Table (%)**

Three-Phase kVA	NEMA TP-1 (National Standard 1/1/2007–12/31/2015)	NEMA Premium®	CSL3	DOE 2016 (National Standard 1/1/2016)
15	97.0	97.90	97.98	97.89
30	97.5	98.25	98.29	98.23
45	97.7	98.39	98.45	98.40
75	98.0	98.60	98.64	98.60
112.5	98.2	98.74	98.76	98.74
150	98.3	98.81	98.85	98.83
225	98.5	98.95	98.96	98.94
300	98.6	99.02	99.04	99.02
500	98.7	99.09	99.15	99.14
750	98.8	99.16	99.23	99.23
1000	98.9	99.23	99.28	99.28

**Table 19.0-2. DOE 2016 Minimum Efficiency Levels for Low-Voltage Dry-Type Distribution Transformers**

Single-Phase		Three-Phase	
kVA	Efficiency %	kVA	Efficiency %
15	97.70	15	97.89
25	98.00	30	98.23
37.5	98.20	45	98.40
50	98.30	75	98.60
75	98.50	112.5	98.74
100	98.60	150	98.83
167	98.70	225	98.94
250	98.80	300	99.02
333	98.90	500	99.14
—	—	750	99.23
—	—	1000	99.28

---

*This page intentionally left blank.*

**DOE 2016 Energy-Efficient Transformers****10 CFR Part 431 Energy-Efficient Ventilated Transformer**

Eaton's family of energy-efficient ventilated transformers meet DOE 2016 efficiency requirements and federal energy efficiency laws mandated by the Energy Policy Act of 2005 and 10 CFR Part 431 (2016). Distribution transformers installed in the United States are required to meet these energy efficiency requirements. Energy-efficient transformers are especially designed to have low no load (core) losses. Minimum efficiency levels have been established for these transformers when loaded at 35% of their full load capacity. Available 600 V. Eaton offers a wide variety of energy-efficient transformers, including 150 °C, 115 °C or 80 °C; general purpose or K-factor rated; with aluminum or copper windings. Eaton's energy-efficient transformers are manufactured with a NEMA 2 enclosure as standard, and are suitable for installation outdoors when a NEMA 3R weathershield kit is installed. Eaton's energy-efficient transformers use a 220 °C insulation system with 150 °C temperature rise as standard.

Installation of energy-efficient transformers may help facilities earn points toward LEED® certification from the U.S. Green Building Council.

**K-Factor Rated Nonlinear Transformers****Ventilated Transformer**

Eaton K-Factor nonlinear transformers are specifically designed to withstand the harmful overheating effects caused by harmonics generated by nonlinear (non-sinusoidal) loads. These loads include computers, laser printers, copiers and other office equipment, as well as video monitors and other electronic equipment. The core and coils of K-Factor transformers are especially designed to have reduced induction levels, which result in a reduction in stray losses. Oversized (200% rated) neutrals and electrostatic shielding are provided as standard on K-Factor transformers. Eaton K-Factor transformers are available in ratings with a K-factor of 4, 9, 13, 20, 30, 40 and 50. 600 V-class single-phase models are available to 167 kVA; three-phase ratings to 1500 kVA. Eaton's family of K-Factor transformers are manufactured with the same high-quality construction features as our ventilated transformer products, including NEMA 2 enclosures and the 220 °C (Class R) insulation system with 150 °C temperature rise as standard.

Refer to **Page 19.1-10** for additional information. Eaton K-Factor-rated transformers are available to meet all 10 CFR Part 431 efficiency levels, including DOE 2016 efficiency.

**Harmonic Mitigating Transformers****Harmonic Mitigating Ventilated Transformer**

Eaton's harmonic mitigating transformers (HMTs) are specially designed transformers that treat a wide variety of harmonics. Also called "phase-shifting" transformers, their low zero-sequence impedance wye zig-zag secondary windings prevent harmful triplen (3rd, 9th, 15th, etc.) harmonic currents from coupling into the primary delta, where they can progress upstream to the service entrance. Multiple HMTs with a variety of phase-shift configurations can be applied in a coordinated scheme to target 5th, 7th, and higher order harmonics at the common bus feeding all of the transformers. HMTs are ideally suited for installations rich in harmonic loads, such as educational facilities (K-12 and universities), government, commercial, medical and call-center applications. HMTs are manufactured with the same high-quality features as Eaton's ventilated transformers, including NEMA 2 enclosures and the 220 °C (Class R) insulation system with 150 °C temperature rise as standard. Additionally, Eaton's HMTs are manufactured with a 200% neutral and electrostatic shield as standard.

Refer to **Page 19.1-11** for additional information.

HMTs are available in four configurations:

- Type NON (0° phase-shift)
- Type THR (30°)
- Type POS (+15°)
- Type NEG (-15°)

Available in three-phase ratings to 1000 kVA and 600 V. Eaton HMTs are available to meet all 10 CFR Part 431 efficiency levels, including DOE 2016 efficiency.

## Motor Drive Isolation Transformers



**Motor Drive Isolation Ventilated Transformer**

Eaton's motor drive isolation transformers are especially designed for three-phase, SCR-controlled, variable-speed motor drive load profiles. Sized by horsepower and common motor voltages, motor drive isolation transformers are braced to withstand the mechanical stresses associated with AC adjustable frequency drives or DC drives. Available in three-phase ventilated designs to 1500 hp and 600 V. Epoxy encapsulated three-phase designs are available to 20 hp. Motor drive isolation transformers are manufactured using the same high-quality construction features as our ventilated transformer products, including NEMA 2 enclosures and the 220 °C (Class R) insulation system with 150 °C temperature rise as standard. Epoxy encapsulated models have NEMA 3R enclosures and 115 °C temperature rise as standard. All Eaton three-phase ventilated motor drive isolation transformers include a normally open dry contact temperature sensor installed in the coils; encapsulated models are not available with this sensor. This sensor can be connected to provide advance alert or warning of a potential overheating of the transformer.

Refer to **Page 19.1-15** for additional information.

Read the text on **Page 19.0-5** on the Energy Policy Act of 2005 before specifying these units. These units are exempt from 10 CFR Part 431 efficiency requirements.

## Hazardous Location Transformers



**Hazardous Location Transformers**

Eaton's hazardous location transformers are suitable for use in environments classified by the National Electrical Code® (NEC®) as Class I, Division 2, Groups A, B, C and D, as defined by NEC Article 501, when installed in compliance with NEC-recommended procedures for dry-type transformers rated 600 V and below. As defined by NEC Article 500, Class I, Division 2 locations include atmospheres that may contain volatile or ignitable concentrations of flammable liquids or gas vapors, or locations adjacent to such environments. Acetone, ammonia, benzene, gasoline, methane, propane and natural gas are examples of such substances.

Eaton's hazardous location transformers are of the encapsulated design, and are available up to 600 V ratings. Single-phase ratings 0.05 kVA through 25 kVA; three-phase ratings to 112.5 kVA. Aluminum windings are standard, with copper as an option. Hazardous location transformers use a 180 °C insulation system with 115 °C temperature rise as standard. 80 °C rise is an available option.

Refer to **Page 19.1-16** for additional information.

## Mini-Power Center



**Mini-Power Center**

An Eaton mini-power center replaces three individual components:

- Primary main breaker
- Transformer
- Distribution loadcenter.

The mini-power center combines all three into a single unit. All interconnecting wiring is performed at the factory. Mini-power centers are ideally suited for applications where 120 V is required at a remote location. Parking lots, workbenches and temporary power on construction sites are common applications for mini-power centers. Available in single-phase and three-phase ratings to 600 V, 100 A, and 30 kVA with secondary loadcenters with provisions for up to 24 single-pole branch breakers. Available with aluminum bus and plug-on branch breakers, or with copper bus and bolt-on branch breakers.

Mini-power centers incorporate an encapsulated transformer in their construction, and are NEMA 3R rated for outdoor applications. Eaton's mini-power centers are UL Listed for use as service entrance devices.

Refer to **Page 19.1-17** for additional information.



## Shielded Isolation Transformers



**Shielded Isolation Ventilated Transformer**

Eaton's shielded isolation transformers are typically installed where "sensitive" loads such as input circuits of computers, medical equipment and microprocessors require additional protection from high-frequency electrical disturbances. Shielded isolation transformers include an electrostatic shield (Faraday shield) installed between the primary and secondary windings. This shield is grounded to the core of the transformer to attenuate high-frequency electrical disturbances in the load from being transmitted to the line side of the transformer. Shielded isolation transformers are available in all sizes and ratings of encapsulated and ventilated transformers. By design, all K Factor and harmonic mitigating transformers include a single, aluminum electrostatic shield as standard.

Shielded isolation transformers are available that meet 10 CFR Part 431 (DOE 2016) efficiency requirements.

Read the text on **Page 19.0-5** on the Energy Policy Act of 2005 before specifying these units.

## Marine Duty Transformers



**Marine-Duty Ventilated Transformer**

Eaton's marine-duty transformers are "Type Approved" by the American Bureau of Shipping (ABS) for on-board use in steel vessels (not for propulsion systems or combat vessels). These transformers are typically installed below deck in electrical or mechanical rooms where the ambient temperature is greater than normal. Eaton's marine-duty transformers are especially designed for operation in 50 °C ambient locations. Marine-duty rated transformers are manufactured with copper windings as standard. Encapsulated designs are available in single-phase ratings 0.05 kVA through 37.5 kVA; three-phase designs 15 kVA through 112.5 kVA. Ventilated designs are available in single-phase ratings of 15 kVA through 250 kVA; three-phase designs 15 kVA through 1000 kVA. Encapsulated and ventilated models are available up to 600 V ratings. The standard temperature rise of Eaton's marine-duty transformers is 115 °C.

Read the text on **Page 19.0-5** on the Energy Policy Act of 2005 before specifying these units.

## "Buck-Boost" and Low-Voltage Lighting Transformers



**Buck-Boost Transformers**

Eaton's Buck-Boost transformers are ideally suited to applications where the available voltage needs to be slightly increased ("boosted") or decreased ("bucked") to be used in a specific application. When Buck-Boost transformers are wired as autotransformers, they can be used to accomplish this bucking or boosting of voltage. Buck-Boost transformers are single-phase encapsulated transformers and are available in three voltage combinations;

- 120 x 240-12/24
- 120 x 240-16/32
- 240 x 480-24/48

...and are available in 0.05 kVA through 7.5 kVA. These transformers can also be used at their nameplate voltages for applications such as low-voltage interior or landscape lighting.

Description

**General Construction Features of General Purpose (DOE 2016, including K-Factor DOE 2016 and HMT DOE 2016) Ventilated Transformers Rated 600 V and below**

**General Description**

Eaton’s single-phase and three-phase general purpose dry-type ventilated transformers are of the two-winding type, self-cooled, and are available in a wide variety of primary and secondary voltage combinations.

Eaton’s transformers are designed, manufactured and tested in accordance with all of the latest applicable ANSI, NEMA and IEEE standards. All 600 V class ventilated transformers with ratings through 1500 kVA are UL® listed and bear the UL label. Open core and coil assemblies are UR labeled products.

These transformers are designed for continuous operation at rated kVA for 24 hours a day, 365 days a year, with normal life expectancy as defined in ANSI C57.96.

**Efficiency validation:** Eaton-manufactured transformers in compliance with 10 CFR Part 431 (2016), “DOE 2016 efficient” bear the UL Energy Efficiency Verification Mark to confirm that the transformer meets the energy efficiency requirements set forth in federal law 10 CFR Part 431.

**Insulation System**

Industry standards classify insulation systems and temperature rise as shown below.

Table 19.1-1. Insulation System Classified

Ambient Temperature	+ Winding Rise	+ Hot Spot	= Temp. Class
40 °C	80 °C	30 °C	150 °C
40 °C	115 °C	30 °C	185 °C
40 °C	150 °C	30 °C	220 °C

The design life of transformers having different insulation systems is the same; the lower temperature systems are designed for the same life as the higher temperature systems.

Most Eaton ventilated transformers, regardless of their temperature rise, are manufactured using a 220 °C insulation system. Required performance is obtained without exceeding the insulation system rating at rated temperature rise in a 40 °C maximum ambient, with an average ambient temperature of 30 °C over a 24-hour period. Transformers manufactured with 220C insulation system meet the requirements of NEC 450.21(b) Exception No.2. It is not necessary to install them in a special, fire-resistant room.

All insulation materials used are flame-retardant and do not support combustion as defined in ASTM Standard Test Method D635.

**Core and Coil Assemblies**

The transformer core is constructed using high-grade, non-aging, silicon steel with high magnetic permeability, and low hysteresis and eddy current losses. Maximum magnetic flux densities are substantially below the saturation point. The transformer core volume allows for efficient transformer operation at 10% above the nominal tap voltage. The core laminations are tightly clamped and compressed. Coils are wound of electrical grade aluminum or copper, and are of continuous wound construction. The BIL (basic impulse level) for all 600 V-class windings is 10 kV. The core and coil assembly is installed on neoprene vibration-absorbing pads.

Ventilated transformers with wye-connected secondaries have the neutral brought out to a separate XO terminal or busbar.

The core and coil assembly is grounded to the transformer enclosure by means of a visible flexible copper ground strap. The copper ground strap is sized per the NEC to be a grounding conductor.

Eaton three-phase DOE 2016 efficient transformers are provided with a bonding ground bar attached to the bottom panel for compliance with NEC 450.10(A).

**Electrostatic Shielding**

There are no industry standards for electrostatic shield performance. Eaton-manufactured transformers have been tested by an independent laboratory to meet the following attenuation levels:

When tested per MIL-Std-220A, Method of Insertion Loss Measurement, with matched impedance no load technique:

1. Common mode noise attenuation: Minus 80 dBA minimum at 0.1 kHz to 1.5 kHz; minus 55 dBA minimum at 1.51 kHz to 100 kHz.
2. Normal mode (Transverse mode) noise attenuation: Minus 35 dBA minimum at 1.5 kHz to 10 kHz.

Primary to Secondary Capacitance of 24.74–18.06 picofarads on the range 100–20 kHz.

**Description**

**Taps**

Primary taps are available on most Eaton ventilated transformers to allow compensation for source voltage variations.

**Winding Terminations**

Primary and secondary windings are terminated in the wiring compartment. Encapsulated units have copper leads or stabs brought out for connections. Ventilated transformers have leads brought out to aluminum or copper pads that are pre-drilled to accept Cu/Al lugs. Aluminum-wound transformers have aluminum pads; copper-wound transformers have copper pads. Lugs are not supplied with Eaton transformers; however, lug kits are available as a field-installed accessory. Eaton recommends external cables be rated 90 °C (sized at 75 °C ampacity) for encapsulated designs and rated 75 °C for ventilated designs.

**Series-Multiple Windings**

Series-multiple windings consist of two similar coils in each winding that can be connected in series or parallel (multiple). Transformers with series-multiple windings are designated with an "x" or a "/" between the voltage ratings, such as voltages of "240 x 480" or "120/240." If the series-multiple winding is designated by an "x," the winding can be connected only in series or parallel. With a "/" designation, a mid-point also becomes available in addition to the series or parallel connection. As an example, a 240 x 480 winding can be connected for either 240 (parallel) or 480 (series). A 120/240 winding can be connected for either 120 (parallel) or 240 (series), or 240 with a 120 mid-point.

**Enclosures**

The transformer enclosure is made of heavy-gauge steel and is finished using a continuous process of degreasing, cleaning and phosphatizing, followed by electrostatic deposition of a thermo-setting polyester powder coating and subsequent baking. The coating color is ANSI 61 and is UL recognized for outdoor use. In compliance with NEMA ST-20, Eaton's ventilated transformers are designed such that the maximum temperature on the top of the enclosure does not exceed 50 °C rise above the ambient temperature.

For ventilated transformers, the enclosure construction is ventilated, drip-proof, NEMA 2, with lifting provisions.

All ventilation openings are protected against falling dirt. Proper installation of weathershields on ventilated transformers makes the enclosure NEMA 3R rated and suitable for outdoor use.

To ensure proper ventilation and cooling of the transformer, follow manufacturer's recommended clearances around ventilation openings.

**Installation Clearances**

Eaton's transformers should be installed with a minimum clearance around the transformer enclosure to prevent accidental contact with flammable or combustible materials. The minimum required clearance from the back panel varies by transformer design. Many small kVA ventilated transformers (150 kVA and smaller) require just 2 inches of clearance, while larger kVA transformers require 6-inch clearance or more. Minimum installation clearances are stated on the nameplate of all transformers. The NEC requires a minimum of 36 inches clearance in front of the transformer for safe installation and maintenance. Care should be taken to avoid restricting the airflow through the bottom of the transformer.

Transformers should be located in areas not accessible to the public.

**Sound Levels**

All transformers emit some audible sound due mainly to the vibration generated in their core by alternating flux. NEMA ST-20 defines the maximum average sound levels for transformers.

All Eaton ventilated transformers are designed to have audible sound levels lower than those required by NEMA ST-20 (2014). However, consideration should be given to the specific location of a transformer and its installation to minimize the potential for sound transmission to surrounding structures and sound reflection. Installation and ambient conditions at a specific location can result in field-measured audible sound levels as much as 15 dBA greater than those levels measured in a sound-proof chamber. The following installation methods should be considered:

1. If possible, mount the transformer away from corners of walls or ceilings. For installations that must be near a corner, use sound-absorbing materials on the walls and ceiling if necessary to eliminate reflection.
2. Provide a solid foundation for mounting the transformer and use vibration dampening mounts if not already provided in the transformer. Eaton's ventilated transformers contain a built-in vibration dampening system to minimize and isolate sound transmission. However, supplemental vibration dampening mounts installed between the floor and the transformer may provide additional sound dampening.

**Table 19.1-2. NEMA ST-20 (2014) Maximum Audible Sound Levels for 600 V Class Transformers (dBA)**

Equivalent Winding kVA Range	Average Sound Level, Decibels			
	Self-Cooled Ventilated			Self-Cooled Sealed
	A	B	C	D
	K Factor = 1 K Factor = 4 K Factor = 9	K Factor = 13 K Factor = 20	Forced Air When Fans Running	
3.00 and below	40	40	67	45
3.01 to 9.00	40	40	67	45
9.01 to 15.00	45	45	67	50
15.01 to 30.00	45	45	67	50
30.01 to 50.00	45	48	67	50
50.01 to 75.00	50	53	67	55
75.01 to 112.50	50	53	67	55
112.51 to 150.00	50	53	67	55
150.01 to 225.00	55	58	67	57
225.01 to 300.00	55	58	67	57
300.01 to 500.00	60	63	67	59
500.01 to 700.00	62	65	67	61
700.01 to 1000.00	64	67	67	63
Greater than 1000	Consult factory			

**Note:** Consult factory for nonlinear requirements exceeding a K-factor rating of 20. When the fans are not running, columns A and B apply. Sound levels are measured using the A-weighted scale (dBA).

### Description

3. Make electrical connections to the transformer using flexible conduit.
4. Locate the transformer in an area where audible sound is not offensive to building inhabitants.
5. If a transformer is going to be installed in a location where the audible sound could be objectionable, consider installing a transformer specifically designed to have reduced sound levels. Eaton offers many transformers with a sound reduction up to 5 dB below NEMA ST-20 limits.

### Applicable Standards

600 V-class ventilated transformers are manufactured per the following standards:

- UL 1561
- NEMA ST-20
- ANSI C57.12.01
- IEC 60726 for CE-marked ventilated models

### Seismic Qualification



Refer to **Tab 1** for information on seismic qualification for this and other Eaton products.

### Standard Production Tests

The following production tests are performed as standard on all Eaton transformers, prior to shipment:

1. Ratio tests at the rated voltage connection and at all tap connections.
2. Polarity and phase relation tests on the rated voltage connection.
3. Applied potential tests.
4. Induced potential tests.
5. No-load and excitation current at rated voltage on the rated voltage connection.

### Operation

Eaton's ventilated transformers are designed for continuous operation at rated kVA for 24 hours a day, 365 days a year, with normal life expectancy as defined in ANSI C57.96.

Short-term overload capacity is designed into transformers, as required by ANSI. Ventilated transformers will deliver 200% of nameplate load for 30 minutes; 150% of nameplate load for 1 hour; and 125% of nameplate load for 4 hours without being damaged, provided that a constant 50% load precedes and follows the overload. Refer to ANSI C57.96-01.250 for additional limitations.

**Note:** Continuous overload capacity is not deliberately designed into transformers. The design objective is to be within the allowable winding temperature rise at nameplate full load capacity.

However, because Eaton's ventilated transformers are manufactured using a 220 °C insulation system, 115 °C and 80 °C low temperature rise transformers can be operated as 150 °C rise transformers. The excess thermal capacity of these low temperature rise transformers allows a 115 °C transformer to be operated as a 150 °C rise transformer and overloaded by 15% of its nameplate kVA without compromising the normal life of the transformer. Likewise, an 80 °C rise transformer operated as a 150 °C rise transformer is capable of a constant 30% overload without compromising the normal life expectancy of the transformer.

**Table 19.1-3. Rated Line Amperes for kVA and Voltages of Single-Phase Transformers**

kVA Rating	Rated Line Voltage								
	120	208	240	277	480	600	2400	4160	4800
1	8.3	4.8	4.2	3.6	2.1	1.7	0.4	0.2	0.2
1.5	12.5	7.2	6.3	5.4	3.1	2.5	0.6	0.4	0.3
2	16.7	9.6	8.3	7.2	4.2	3.3	0.8	0.5	0.4
3	25.0	14.4	12.5	10.8	6.3	5.0	1.3	0.7	0.6
5	41.7	24.0	20.8	18.0	10.4	8.3	2.1	1.2	1.0
7.5	62.5	36.6	31.3	27.1	15.6	12.5	3.1	1.8	1.6
10	83.3	48.1	41.7	36.1	20.8	16.7	4.2	2.4	2.1
15	125.0	72.1	62.5	54.2	31.3	25.0	6.3	3.6	3.1
25	208.3	120.2	104.2	90.3	52.1	41.7	10.4	6.0	5.2
37.5	312.5	180.3	156.3	135.4	78.1	62.5	15.6	9.0	7.8
50	416.7	240.4	208.3	180.5	104.2	83.3	20.8	12.0	10.4
75	625.0	360.6	312.5	270.8	156.3	125.0	31.3	18.0	15.6
100	833.3	480.8	416.7	361.0	208.3	166.7	41.7	24.0	20.8
167	1391.7	802.9	695.8	602.9	347.9	278.3	69.6	40.1	34.8
250	2083.3	1201.9	1041.7	902.5	520.8	416.7	104.2	60.1	52.1
333	2775.0	1601.0	1387.5	1202.2	693.8	555.0	138.8	80.0	69.4
500	4166.7	2403.8	2083.3	1805.1	1041.7	833.3	208.3	120.2	104.2

**Note:** Line Current = (kVA x 1000)/Line Voltage.

**Table 19.1-4. Rated Line Amperes for kVA and Voltages of Three-Phase Transformers**

kVA Rating	Rated Line Voltage						
	208	240	480	600	2400	4160	4800
3	8.3	7.2	3.6	2.9	0.7	0.4	0.4
6	16.7	14.4	7.2	5.8	1.4	0.8	0.7
9	25.0	21.6	10.8	8.7	2.2	1.3	1.1
15	41.6	36.1	18.0	14.4	3.6	2.1	1.8
30	83.3	72.2	36.1	28.9	7.2	4.2	3.6
45	125.0	108.4	54.2	43.3	10.9	6.3	5.4
75	208.2	180.4	90.2	72.2	18.0	10.4	9.0
112.5	312.5	271.6	135.3	108.2	27.1	15.6	13.5
150	416.3	360.8	180.4	144.3	36.1	20.8	18.0
225	625.0	541.9	270.7	216.5	54.2	31.3	27.1
300	832.7	721.7	360.8	288.7	72.2	41.6	36.1
500	1387.8	1202.8	601.4	481.1	120.3	69.4	60.1
750	2081.9	1804.3	902.1	721.7	180.4	104.1	90.2
1000	2775.8	2405.7	1202.9	962.3	240.6	138.8	120.3

**Note:** Three-Phase Line Current = (kVA x 1000)/(Line Voltage x 1.732).

**Description**

**General Construction  
Features of General Purpose  
Encapsulated Transformers  
Rated 600 V and Below**

**General Description**

Eaton's single-phase and three-phase general purpose encapsulated dry-type transformers are of the two-winding type, self-cooled, and are available in a wide variety of primary and secondary voltage combinations.

Eaton's transformers are designed, manufactured and tested in accordance with all of the latest applicable ANSI, NEMA and IEEE standards. All 600 V-class encapsulated transformers with ratings through 112.5 kVA are UL listed and CSA certified, and bear the UL and CSA labels.

These transformers are designed for continuous operation at rated kVA for 24 hours a day, 365 days a year, with normal life expectancy as defined in ANSI C57.96. Encapsulated transformers are outside the scope of U.S. energy efficiency law 10 CFR Part 431 (DOE 2016).

**Insulation Systems**

Industry standards classify insulation systems and temperature rise as shown below.

**Table 19.1-5. Insulation System Classification**

Ambient Temperature	+ Winding Rise	+ Hot Spot	= Temp. Class
40 °C	55 °C	10 °C	105 °C
40 °C	80 °C	30 °C	150 °C
25 °C	135 °C	20 °C	180 °C
40 °C	115 °C	30 °C	185 °C
40 °C	150 °C	30 °C	220 °C

The design life of transformers having different insulation systems is the same; the lower temperature systems are designed for the same life as the higher temperature systems.

Eaton's encapsulated transformers are manufactured using a 180 °C insulation system. Required performance is obtained without exceeding the insulation system rating at rated temperature rise in a 40 °C maximum ambient, with an average ambient temperature of 30 °C over a 24-hour period.

All insulation materials are flame-retardant and do not support combustion as defined in ASTM Standard Test Method D635.

**Core and Coil Assemblies**

The transformer core is constructed using high-grade, non-aging, silicon steel with high-magnetic permeability, and low hysteresis and eddy current losses. Maximum magnetic flux densities are substantially below the saturation point. The transformer core volume allows for efficient transformer operation at 10% above the nominal tap voltage. The core laminations are tightly clamped and compressed. Coils are wound of electrical grade aluminum or copper, and are of continuous wound construction. The BIL (basic impulse level) for all 600 V-class windings is 10 kV. In encapsulated transformers, the core and coil assembly is completely encased in a proportioned mixture of resin or epoxy, and aggregate to provide a moisture-proof, shock-resistant seal. The core and coil encapsulation system is designed to minimize the audible sound level.

**Taps**

Primary taps are available on many Eaton encapsulated transformers to allow compensation for source voltage variations.

**Winding Terminations**

Primary and secondary windings are terminated in the wiring compartment. Encapsulated units have copper leads or stabs brought out for connections. Ventilated transformers have leads brought out to aluminum or copper pads that are pre-drilled to accept Cu/Al lugs. Aluminum-wound transformers have aluminum pads; copper-wound transformers have copper pads. Lugs are not supplied with Eaton's transformers; however, lug kits are available as a field-installed accessory. Eaton recommends external cables be rated 90 °C (sized at 75 °C ampacity) for encapsulated designs and rated 75 °C for ventilated designs.

**Series-Multiple Windings**

Series-multiple windings consist of two similar coils in each winding that can be connected in series or parallel (multiple). Transformers with series-multiple windings are designated with an "x" or a "/" between the voltage ratings, such as voltages of "240 x 480" or "120/240." If the series-multiple winding is designated by an "x," the winding can be connected only in series or parallel. With a "/" designation, a mid-point also becomes available in addition to the series or parallel connection. As an example, a 240 x 480 winding can be connected for either 240 (parallel) or 480 (series). A 120/240 winding can be connected for either 120 (parallel) or 240 (series), or 240 with a 120 mid-point.

**Enclosures**

The transformer enclosure is made of heavy-gauge steel and is finished using a continuous process of degreasing, cleaning and phosphatizing, followed by electrostatic deposition of a thermosetting polyester powder coating and subsequent baking. The coating color is ANSI 61 and is UL recognized for outdoor use. In compliance with NEMA ST-20, Eaton's transformers are designed such that the maximum temperature on the top of the enclosure does not exceed 50 °C rise above the ambient temperature.

For encapsulated transformers, the standard enclosure construction is totally enclosed, non-ventilated NEMA 3R, with lifting provisions. NEMA 4X rated encapsulated transformers are available as an option.

Wall mounting brackets are provided on many Eaton encapsulated transformers. These mounting brackets are designed to provide the proper spacing between the mounting surface and the transformer enclosure.

To ensure proper ventilation and cooling of the transformer, follow manufacturer's recommended clearances around encapsulated transformers.

## Description

### Sound Levels

All transformers emit some audible sound due mainly to the vibration generated in their core by alternating flux. NEMA ST-20 defines the maximum average sound levels for transformers.

All Eaton encapsulated transformers are designed to have audible sound levels lower than those required by NEMA ST-20 (2014). However, consideration should be given to the specific location of a transformer and its installation to minimize the potential for sound transmission to surrounding structures and sound reflection. Installation and ambient conditions at a specific location can result in field-measured audible sound levels as much as 15 dBA greater than those levels measured in a sound-proof chamber. The following installation methods should be considered:

1. If possible, mount the transformer away from corners of walls or ceilings. For installations that must be near a corner, use sound-absorbing materials on the walls and ceiling if necessary to eliminate reflection.
2. Provide a solid foundation for mounting the transformer and use vibration-dampening mounts if not already provided in the transformer. Eaton's encapsulated transformers use a special encapsulation system to minimize and isolate sound transmission. However, supplemental vibration dampening mounts installed between the floor and the transformer may provide for additional sound dampening.
3. Make electrical connections to the transformer using flexible conduit.
4. Locate the transformer in an area where audible sound is not offensive to building inhabitants.
5. If a transformer is going to be installed in a location where the audible sound could be objectionable, consider installing a transformer specifically designed to have reduced sound levels. Eaton offers many transformers with a sound reduction up to 5 dB below NEMA ST-20 limits.

**Table 19.1-6. NEMA ST-20 (2014) Maximum Audible Sound Levels for 600 V Class Transformers (dBA)**

Equivalent Winding kVA Range	Average Sound Level, Decibels			
	Self-Cooled Ventilated			Self-Cooled Sealed
	A	B	C	D
	K Factor = 1 K Factor = 4 K Factor = 9	K Factor = 13 K Factor = 20	Forced Air When Fans Running	
3.00 and below	40	40	67	45
3.01 to 9.00	40	40	67	45
9.01 to 15.00	45	45	67	50
15.01 to 30.00	45	45	67	50
30.01 to 50.00	45	48	67	50
50.01 to 75.00	50	53	67	55
75.01 to 112.50	50	53	67	55
112.51 to 150.00	50	53	67	55
150.01 to 225.00	55	58	67	57
225.01 to 300.00	55	58	67	57
300.01 to 500.00	60	63	67	59
500.01 to 700.00	62	65	67	61
700.01 to 1000.00	64	67	67	63
Greater than 1000	Consult factory			

**Note:** Consult factory for nonlinear requirements exceeding a K-factor rating of 20. When the fans are not running, columns A and B apply. Sound levels are measured using the A-weighted scale (dBA).

**Description**

**Applicable Standards**

600 V-class encapsulated transformers are manufactured per the following standards:

- Encapsulated transformers are outside the scope of energy efficiency mandates, including 10 CFR Part 431
- UL 5085 up to 15 kVA
- UL 1561 15 kVA and larger
- NEMA ST-20
- ANSI C57.12.01
- IEEE C57.12.01
- IEC 61558 for single-phase CE-marked models
- CSA C22.2 No. 47-M90

**Seismic Qualification**



Refer to **Tab 1** for information on seismic qualification for this and other Eaton products.

**Standard Production Tests**

The following production tests are performed as standard on all Eaton transformers, prior to shipment:

1. Ratio tests at the rated voltage connection and at all tap connections.
2. Polarity and phase relation tests on the rated voltage connection.
3. Applied potential tests.
4. Induced potential tests.
5. No-load and excitation current at rated voltage on the rated voltage connection.

**Operation**

Eaton's encapsulated transformers are designed for continuous operation at rated kVA for 24 hours a day, 365 days a year, with normal life expectancy as defined in ANSI C57.96.

Short-term overload capacity is designed into transformers, as required by ANSI. Encapsulated transformers will deliver 200% of nameplate load for 30 minutes; 150% of nameplate load

for 1 hour; and 125% of nameplate load for 4 hours without being damaged, provided that a constant 50% load precedes and follows the overload. Refer to ANSI C57.96-01.250 for additional limitations.

**Note:** Continuous overload capacity is not deliberately designed into transformers because the design objective is to be within the allowable winding temperature rise at nameplate full load capacity.

**Table 19.1-7. Rated Line Amperes for kVA and Voltages of Single-Phase Transformers**

kVA Rating	Rated Line Voltage								
	120	208	240	277	480	600	2400	4160	4800
1	8.3	4.8	4.2	3.6	2.1	1.7	0.4	0.2	0.2
1.5	12.5	7.2	6.3	5.4	3.1	2.5	0.6	0.4	0.3
2	16.7	9.6	8.3	7.2	4.2	3.3	0.8	0.5	0.4
3	25.0	14.4	12.5	10.8	6.3	5.0	1.3	0.7	0.6
5	41.7	24.0	20.8	18.0	10.4	8.3	2.1	1.2	1.0
7.5	62.5	36.6	31.3	27.1	15.6	12.5	3.1	1.8	1.6
10	83.3	48.1	41.7	36.1	20.8	16.7	4.2	2.4	2.1
15	125.0	72.1	62.5	54.2	31.3	25.0	6.3	3.6	3.1
25	208.3	120.2	104.2	90.3	52.1	41.7	10.4	6.0	5.2
37.5	312.5	180.3	156.3	135.4	78.1	62.5	15.6	9.0	7.8
50	416.7	240.4	208.3	180.5	104.2	83.3	20.8	12.0	10.4
75	625.0	360.6	312.5	270.8	156.3	125.0	31.3	18.0	15.6
100	833.3	480.8	416.7	361.0	208.3	166.7	41.7	24.0	20.8
167	1391.7	802.9	695.8	602.9	347.9	278.3	69.6	40.1	34.8
250	2083.3	1201.9	1041.7	902.5	520.8	416.7	104.2	60.1	52.1
333	2775.0	1601.0	1387.5	1202.2	693.8	555.0	138.8	80.0	69.4
500	4166.7	2403.8	2083.3	1805.1	1041.7	833.3	208.3	120.2	104.2

**Note:** Line Current = (kVA x 1000)/Line Voltage.

**Table 19.1-8. Rated Line Amperes for kVA and Voltages of Three-Phase Transformers**

kVA Rating	Rated Line Voltage						
	208	240	480	600	2400	4160	4800
3	8.3	7.2	3.6	2.9	0.7	0.4	0.4
6	16.7	14.4	7.2	5.8	1.4	0.8	0.7
9	25.0	21.6	10.8	8.7	2.2	1.3	1.1
15	41.6	36.1	18.0	14.4	3.6	2.1	1.8
30	83.3	72.2	36.1	28.9	7.2	4.2	3.6
45	125.0	108.4	54.2	43.3	10.9	6.3	5.4
75	208.2	180.4	90.2	72.2	18.0	10.4	9.0
112.5	312.5	271.6	135.3	108.2	27.1	15.6	13.5
150	416.3	360.8	180.4	144.3	36.1	20.8	18.0
225	625.0	541.9	270.7	216.5	54.2	31.3	27.1
300	832.7	721.7	360.8	288.7	72.2	41.6	36.1
500	1387.8	1202.8	601.4	481.1	120.3	69.4	60.1
750	2081.9	1804.3	902.1	721.7	180.4	104.1	90.2
1000	2775.8	2405.7	1202.9	962.3	240.6	138.8	120.3

**Note:** Three-Phase Line Current = (kVA x 1000)/(Line Voltage x 1.732).

Description

## K-Factor Rated Nonlinear Transformers Rated 600 V and Below

### Applications

Eaton K-Factor transformers are specifically designed to withstand the harmful overheating effects caused by harmonics generated by nonlinear (non-sinusoidal) loads. These loads include computers, laser printers, copiers and other office equipment, as well as video monitors and other electronic equipment. Eaton K-Factor transformers are not simply over-sized transformers. The core and coils of our K-Factor transformers are specially designed to have reduced induction levels, which results in a reduction in stray losses. Oversized (200% rated) neutrals and electrostatic shielding are typical features found in our K-Factor transformers. Eaton K-Factor transformers are manufactured with the same high-quality construction features as our other ventilated transformer products, including NEMA 2 enclosures as standard.

### Technical Data

#### Available Ratings

Eaton K-Factor transformers are available in a wide range of ratings to meet specific voltage conversion requirements. Eaton offers transformers with K-factor ratings of 4, 9, 13, 20, 30, 40 and 50.

#### kVA Capacity

Single-phase ventilated designs are available in ratings from 15 kVA through 250 kVA; three-phase ratings 15 kVA through 1500 kVA.

#### Insulation System and Temperature Rise

Eaton-manufactured ventilated transformers are manufactured using a 220 °C insulation system with 150 °C temperature rise as standard. Low temperature rise designs (115 °C and 80 °C temperature rise) are available as options.

#### Frequency

Most ventilated transformers are designed to operate in 60 Hz systems. 50/60 Hz designs are available as an option. Eaton's ventilated transformers can be designed to operate at a variety of frequencies.

#### Winding Material

Aluminum conductor and terminations are provided as standard on ventilated transformers. Copper winding conductors and terminations are available as an option.

### Installation Clearances

Eaton's ventilated transformers should be installed with minimum clearances as noted on the transformer's nameplate. Most Eaton transformers require a minimum of 6 inches clearance behind the transformer; however, many small kVA ventilated transformers may be installed with just 2 inches clearance, while large kVA transformers require 12 inches or more of clearance behind the transformer. Minimum installation clearances are stated on the nameplate of all transformers. The NEC requires a minimum of 36 inches clearance in front of the transformer. Care should be taken to avoid restricting the airflow through the bottom of the transformer. Transformers should be located in areas not accessible to the public.

### Wiring Compartment

Eaton's ventilated transformers have wiring compartments sized to comply with NEMA and NEC standards.

### The K-factor

A common industry term for the amount of harmonics produced by a given load is the K-factor. The larger the K-factor, the more harmonics are present. Linear loads, for example, have a K-factor of 1. Transformers may carry a K-factor rating to define the transformer's ability to withstand the additional heating generated by harmonic currents.

### Calculating the K-factor

All nonlinear waveforms can be broken down mathematically into a fundamental frequency and its harmonics. IEEE C57.110 establishes a direct relationship between these harmonics and transformer heating. Underwriters Laboratories has established a similar relationship, the K-factor, which is derived by summing the square of the percentage current at a given harmonic level multiplied by the square of the harmonic order.

$$K = \sum (I_h)^2 (h)^2$$

$I_h$  = Percent Current at Harmonic  $h$

$h$  = Harmonic Order, i.e., 3rd, 5th, 7th

For example, a load that is 90% of the fundamental, 30% of the third harmonic, and 20% of the fifth harmonic would yield  $(.9)^2(1)^2 + (.3)^2(3)^2 + (.2)^2(5)^2$  or a K-factor of 2.62. This load would require a transformer with a K-factor rating of 4.

Transformers that carry a K-factor rating define the transformer's ability to withstand a given harmonic load while operating within the transformer's insulation class.

An analysis of harmonic loads and a calculation of the K-factor must be made to properly apply transformers in any building or facility. Note that the calculated K-factor is not constant since nonlinear loads change throughout the day as equipment and lighting is turned off and on. These harmonic loads also change over the life of the building or facility as equipment is added or removed.

### Harmonic Currents

Harmonic currents are found in nonlinear loads. These currents are generated by various types of equipment including switching mode power supplies that abruptly switch current on and off during each line cycle. Switching mode power supplies or diode capacitor power supplies convert AC line voltage to low-voltage DC. This process accomplished by charging capacitors during each line cycle with narrow pulses of current that are time-coincident with line voltage peaks. Examples of this equipment include electronic ballasts for fluorescent lighting, personal computers, printers, fax machines, electronic and medical test equipment uninterruptible power supplies and solid-state motor drives.

**Note:** Nonlinear is synonymous with the term non-sinusoidal.

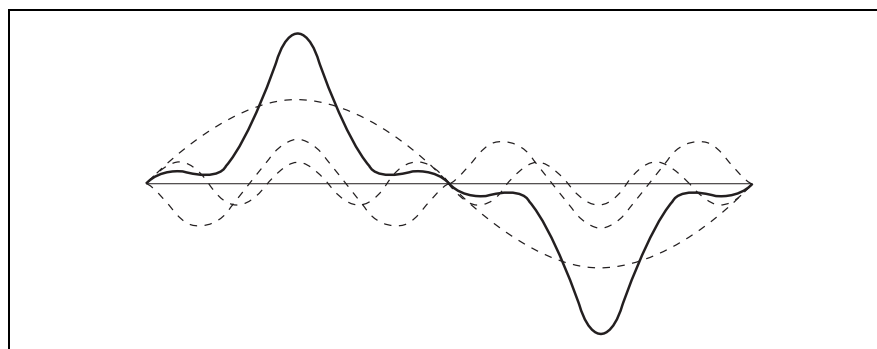

Figure 19.1-1. Harmonic Currents Found in Nonlinear Loads Cause Wave Shape Distortion and Create Added Stresses on Transformers



## Description

**Harmonic Mitigating Transformers Rated 600 V and Below****Applications**

Eaton's harmonic mitigating transformers (HMTs) are specially designed transformers that treat a wide variety of harmonics. Also called "phase-shifting" transformers, their low zero-sequence impedance wye zig-zag secondary windings prevent harmful triplen (3rd, 9th, 15th, etc.) harmonic currents from coupling into the primary delta, where they can progress upstream to the service entrance. Multiple HMTs with a variety of phase-shift configurations can be applied in a coordinated scheme to target 5th, 7th and higher-order harmonics at the common bus feeding all of the transformers. HMTs are ideally suited for installations rich in harmonic loads, such as educational facilities (K-12 and universities), government, commercial, medical and call-center applications. HMTs are manufactured with the same high-quality features as Eaton's ventilated transformers, including NEMA 2 enclosures and the 220 °C (Class R) insulation system with 150 °C temperature rise as standard. Additionally, Eaton's HMTs are manufactured with a 200% neutral and electrostatic shield as standard. Eaton's harmonic mitigating ventilated transformers are designed primarily for indoor installations. Ventilated transformers have NEMA 2 enclosures as standard, and are suitable for installation outdoors when NEMA 3R weathershield kits are installed. Ventilated transformers are typically floor-mounted on an elevated housekeeping pad. When properly supported, they are also suitable for wall mounting or trapeze-mounting from ceilings.

**Technical Data****Available Ratings**

Eaton's harmonic mitigating transformers are available in a wide range of ratings to meet specific voltage conversion requirements. Eaton's HMTs accept a three-phase three-wire input and have a three-phase four-wire (phases and neutral) output.

**kVA Capacity**

Three-phase ratings 15 kVA through 1000 kVA.

**Insulation System and Temperature Rise**

Eaton's harmonic mitigating transformers are manufactured using a 220 °C insulation system with 150 °C temperature rise as standard. Low temperature rise designs (115 °C and 80 °C temperature rise) are available as options.

**Frequency**

Eaton's harmonic mitigating transformers are designed to operate in 60 Hz systems. 50/60 Hz designs are available as an option. The transformers can be designed to operate at a variety of frequencies.

**Winding Material**

Copper conductor and terminations are provided as standard on harmonic mitigating transformers. Aluminum winding conductors and terminations are available as an option.

**Installation Clearances**

Eaton's ventilated transformers should be installed with minimum clearances as noted on the transformer's nameplate. Most Eaton transformers require a minimum of 6 inches clearance behind the transformer; however, many small kVA ventilated transformers may be installed with just 2 inches clearance, while large kVA transformers require 12 inches or more of clearance behind the transformer. Minimum installation clearances are stated on the nameplate of all transformers. The NEC requires a minimum of 36 inches clearance in front of the transformer. Care should be taken to avoid restricting the airflow through the bottom of the transformer. Transformers should be located in areas not accessible to the public.

**Wiring Compartment**

Eaton's ventilated transformers have wiring compartments sized to comply with NEMA and NEC standards.

**Thermal Sensors**

Harmonic mitigating transformers are available with "warning" and/or "alarm" thermal sensors imbedded in their coils. Thermal sensors are normally open dry contacts that can be wired to provide a signal to remote locations to indicate a potential heating problem within the transformer coils. Contacts are rated 180 °C (warning) and 200 °C (alarm).

**Application Considerations**

Eaton offers harmonic mitigating transformers with four different phase-shift options:

- Type NON (0° phase-shift)
- Type POS (+15° phase-shift)
- Type NEG (-15° phase-shift)
- Type THR (-30° phase-shift)

To select the proper HMT, the nonlinear load profile of a particular application must be known.

Type NON (0°) HMTs are ideally suited for treating 3rd and other triplen harmonics that are the signature of single-phase nonlinear loads. This is the most common application encountered. Type NON HMTs use electromagnetic flux cancellation to cancel triplen harmonics. There, harmonics are treated in the secondary windings and prevented from coupling into the primary delta windings, where they may be transmitted upstream to the service entrance location. Type NON HMTs can be deployed singly to treat triplen harmonics. As with most other harmonic mitigating methods, the closer the HMT can be installed to the load, the greater the benefit.

Type POS (+15°) and Type NEG (-15°) harmonic mitigating transformers are typically used together in coordinated pairs to treat 5th, 7th and other harmonics that are generated by three-phase nonlinear loads. 5th, 7th and higher order harmonics pass through the harmonic mitigating transformers, to a point of common coupling; the first common electrical point that is shared by the HMTs. At this common point, balanced portions of the 5th, 7th, etc., harmonic currents are canceled and prevented from flowing further upstream in the distribution system. Type POS and Type NEG HMTs have nearly identical electrical characteristics, including zero-sequence and positive-sequence impedance and reactance. The more closely matched the coordinated pairs of transformers, the more thorough the harmonic cancellation.

Coordinated pairs of Type NON and Type THR transformers, as well as coordinated pairs of Type NON, Type THR, Type POS and Type NEG HMTs provide treatment of 3rd and other triplen harmonics within their secondary windings. This cancellation is achieved by virtue of their wye zig-zag winding configuration.

Description

### Harmonic Mitigating Transformers

As our world becomes even more dependent on electrical and electronic equipment, there is an increased likelihood that operations will experience the negative effects of harmonic distortion. The productivity and efficiency gains achieved from increasingly sophisticated pieces of equipment have a drawback: increased harmonic distortion in

the electrical distribution system. The difficult thing about harmonic distortion is determining the source. Once this task has been completed, the solution can be easy. Harmonic mitigating transformers (HMTs) are one of the many possible solutions to help eliminate these harmful harmonics.

### What are Harmonics?

An understanding of how harmonics are generated and what harmonics really are is necessary in order to understand how HMTs can provide harmonic mitigation. Electronic equipment requires DC voltage to operate. Rectifiers and capacitors are used to convert AC voltage to DC voltage within the equipment. These devices are frequently referred to as switch mode power supplies. As the capacitors charge and discharge during this conversion, the capacitor draws current in pulses, not at a continuous rate. This irregular current demand, as depicted in **Figure 19.1-2**, distorts the linear 60 Hz sine wave. As a result, these types of loads are commonly referred to as non-sinusoidal, or nonlinear.

As shown in **Figures 19.1-3** and **19.1-4**, the waveform created by the nonlinear source is actually the mathematical sum of several sine waves, each with a different frequency and magnitude. Each of these individual waveforms is called a harmonic, and is identified by its frequency relative to the fundamental frequency, 60 Hz. In other words, each individual harmonic is identified by a number, which is the number of complete cycles the specific harmonic goes through in a single 60 Hz cycle.

In **Figure 19.1-4**, the fundamental frequency is 60 Hz. The fundamental frequency is assigned the harmonic number of 1, and is the benchmark for all other harmonic numbering. The fundamental, 60 Hz sine wave completes 60 full cycles in one second. The 3rd harmonic completes three full cycles in the time it takes the fundamental to complete just one cycle, or 180 cycles per second. Likewise, the 5th harmonic completes five full cycles in the time it takes the fundamental harmonic to complete a single cycle, which equates to 300 cycles per second. Odd multiples of the 3rd harmonic (3rd, 9th, 15th, 21st, etc.) are commonly referred to as triplen harmonics.

The proliferation of electronic equipment (including computers, fax machines, copiers, electronic ballasts, office equipment, cash registers, slot machines, electronic monitoring devices, video games, medical diagnostic equipment and the like) is what makes single-phase devices the most common source of harmonics. These devices generate a typical waveform shown in **Figure 19.1-2**, and have a harmonic profile as shown in **Table 19.1-9**. As one can see, the predominant harmonic is the 3rd harmonic.

Three-phase, nonlinear loads such as drives, on the other hand, are typically rich in 5th and 7th harmonics.

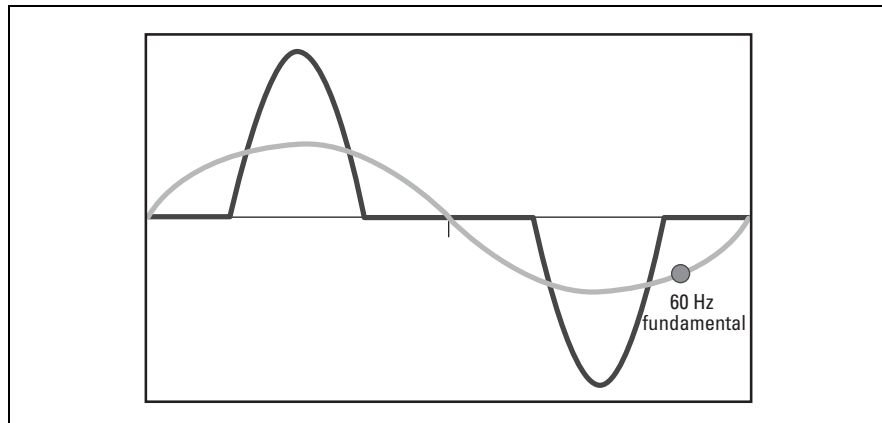

Figure 19.1-2. Typical Waveform of Single-Phase Devices

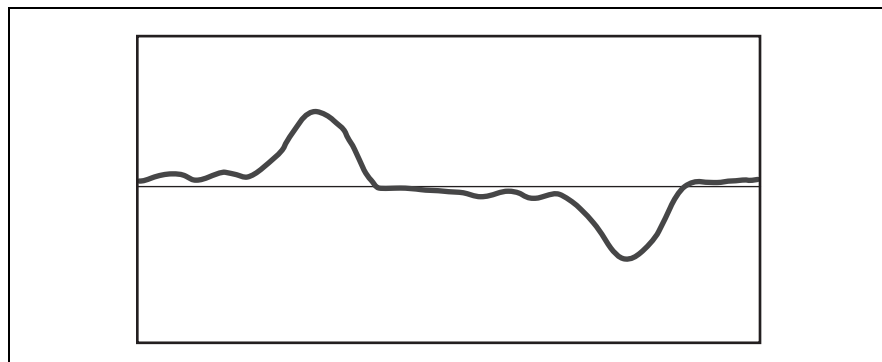

Figure 19.1-3. Composite Waveform

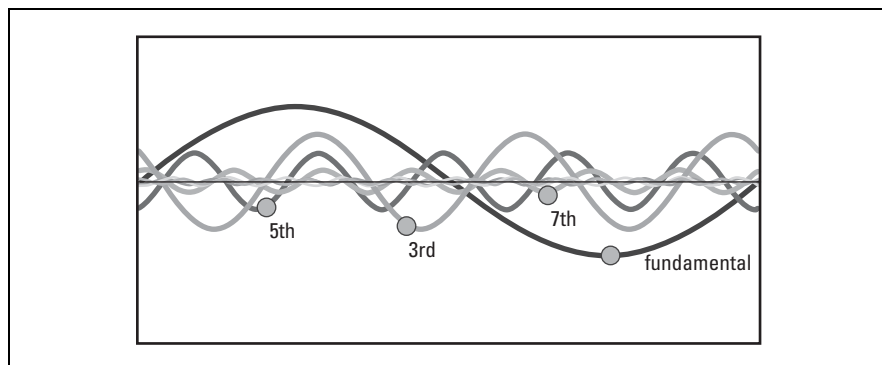

Figure 19.1-4. Components of a Nonlinear Waveform

## Description

**What Problems do Harmonics Cause?**

The distorted current waveform that is created by nonlinear loads can cause many problems in an electrical distribution system. Depending upon the severity of the harmonic distortion, the negative effects of harmonics may be tolerable, and the installation of a K-factor-rated transformer may be an adequate solution. K-factor-rated transformers do not provide any harmonic treatment. Rather, they are designed to withstand the destructive effects of the additional heat generated by harmonic currents in the transformer's windings.

In many instances, the harmful effects of harmonics are too severe, and simply tolerating them is not an acceptable option. Harmonic currents can cause excessive heating in distribution transformers. This additional heat not only reduces the life expectancy of a transformer, it also reduces the usable capacity of the transformer. Another side effect is that the audible noise of a transformer may be amplified when installed in a system that contains harmonics.

An important characteristic of harmonics is that they are transmitted upstream from the load, to the transformer's secondary windings, through the primary windings of the transformer, back to the service entrance, and eventually to the utility lines.

Harmonic currents flowing upstream from nonlinear loads, through the system impedance of cables and transformers, create harmonic voltage distortion. When linear loads, like motors, are subjected to harmonic voltage distortion, they will draw a nonlinear harmonic current. As with distribution transformers, harmonic currents cause increased heating, due to iron and copper losses, in motors and generators. This increased heating can reduce the life of the motor, as well as the motor's efficiency. In electrical cables, harmonic currents may also create increased heating, which can lead to premature aging of the electrical insulation. Nuisance tripping of the circuit breakers protecting the cable may also occur. Communications equipment and data processing equipment are especially susceptible to the harmful effects of harmonics because they rely on a nearly perfect sinusoidal input. This equipment may malfunction, or even fail, when installed in systems that are rich in harmonics.

The costs associated with downtime resulting from the malfunction or failure of electrical or electronic equipment can be staggering. These costs can easily surpass thousands, if not millions, of dollars per hour in lost production or lost productivity. In addition to the well-defined costs associated with the most catastrophic of harmonic effects, there are many less quantitative costs that are often overlooked when evaluating the need for harmonic mitigation. The increased heating caused by harmonics in cables, motors and transformers increases the cooling requirements in air-conditioned areas. The same increases in heating result in increased maintenance costs and more frequent equipment replacement in order to avoid failures that could shut down a building for a period of time.

**What do HMTs do?**

HMTs are an economical solution in the battle against the harmful effects of harmonics. HMTs are passive devices: they don't have any moving parts and they are typically energized 24 hours a day, 7 days a week, 365 days a year. This means that they are always "on the job" treating harmonics, regardless of the level of load they are serving at a given point in time. Whenever the HMT is energized, it will provide harmonic treatment.

Harmonic mitigating transformers are commonly referred to as "phase-shifting" transformers. The HMT offering from Eaton's electrical business has delta-connected primary windings and wye zig-zag connected secondary windings. The use of wye zig-zag secondary windings allows a transformer to be designed in a wide variety of different phase-shifts ( $-30^\circ$ ,  $-15^\circ$ ,  $0^\circ$ ,  $+15^\circ$ ). In standard delta-wye transformers, including K-factor-rated transformers, triplen harmonics are passed from the secondary windings into the primary delta windings, where they are trapped and circulate. In HMTs, the electromagnetic flux cancellation created by the wye zig-zag winding configuration prevents 3rd and other triplen harmonics from being transmitted into the primary delta winding. Harmonic treatment is provided entirely by electromagnetic flux cancellation; no filters, capacitors or other such devices are used. It is important to remember that the harmonic currents still flow in the secondary windings.

Description

**Benefits of Installing HMTs**

In addition to improved system reliability and reduced maintenance costs, HMTs also have excellent energy-saving characteristics. With the cost of electricity continuing to increase around the world, there is an ever-increasing interest in energy-efficient products. In many facilities, the cost of electricity is the second largest expense, eclipsed only by salaries and wages.

Transformers consume energy even when they are lightly loaded or not loaded at all. Significant energy savings may be attained if the no-load losses of a transformer are reduced. 10 CFR Part 431 addresses this issue by requiring high efficiency levels when a transformer is loaded at 35% of its full capacity. However, this standard applies to linear load profiles only, and tests to validate compliance with 10 CFR Part 431 are performed using linear loads.

In actual applications, the growing presence of electronic devices creates nonlinear load profiles. Nonlinear loads cause the losses in distribution transformers to increase, thereby reducing their realized efficiency. Therefore, 10 CFR Part 431 efficiency compliance may not be a true indication of the efficiency of a transformer exposed to nonlinear loads. Though a measure of linear load efficiency, Eaton's family of HMTs meets the efficiency standards set forth in 10 CFR Part 431. Because HMTs are intended to be installed in systems that contain high levels of nonlinear loads, Eaton's family of HMTs is designed to meet the 10 CFR Part 431 efficiency levels when applied to nonlinear load profiles with 100% harmonic distortion, across a broad range of load levels, not just the 35% load level used in 10 CFR Part 431. These energy savings are realized over the entire life of the transformer.

**Table 19.1-9. Typical Harmonic Profile of Single-Phase Switched Mode Power Supply**

Harmonic	Magnitude
1	1.000
3	0.810
5	0.606
7	0.370
9	0.157
11	0.024
13	0.063
15	0.079

**Application Information**

The closer that an HMT can be located to the load, the greater the benefits of harmonic treatment. Installation of a large capacity HMT at the service entrance of a large building would certainly provide some harmonic treatment. However, installation of several smaller rated HMTs, perhaps one or more on each floor of a building, provides greater benefits that will be noticed throughout the facility. For this reason, the most popular HMTs will be rated 75 kVA and less. This complements the cost-efficiencies that can be gained by distributing higher voltages through smaller cables to the point where a safer, lower voltage is needed to operate equipment.

When connecting the loads to the transformer, it is important to remember that the balanced portion of the harmonic loads will be treated. To achieve the maximum harmonic treatment, when considering the triplen harmonics that are treated in the secondary windings, each phase should be balanced, and the harmonic profile of the loads should be as similar as possible. When treating 5th, 7th and higher order harmonics by using multiple transformers, the loads should likewise have similar harmonic profiles, and the kVA and impedance of the transformers should be identical as well. For example, two 75 kVA HMTs can be "paired" with a single 150 kVA HMT to provide maximum harmonic performance. In instances where transformers of unequal kVA are used in combination, harmonic treatment is provided for the lowest kVA load. For example, if, instead of pairing two 75 kVA HMTs with a single 150 kVA HMT, one would pair two 45 kVA HMTs with a 150 kVA HMT. Only 90 kVA (two times 45 kVA) of the 150 kVA load would be treated (if they were fully loaded). In real-world situations, it is nearly impossible to have perfectly matched loads. However, the benefits of treating harmonics, even in situations where the loads are unbalanced, are a far superior option than to not treat them at all.

Eaton HMT transformers comply with applicable 10 CFR Part 431 efficiency standards.

## Description

**Motor Drive Isolation Transformers Rated 600 V and Below****Applications**

Eaton's motor drive isolation transformers are especially designed for three-phase SCR controlled, variable speed motor drives load profiles. Sized by horsepower and common motor voltages, motor drive isolation transformers are braced to withstand the mechanical stresses associated with AC adjustable frequency drives or DC drives. Two-winding drive isolation transformers provide:

- Electrical isolation between the incoming line and the drive circuitry
- Voltage conversion on input line to standard drive input voltages
- Help to minimize line disturbances caused by SCR firing
- Reduce short-circuit currents and voltage line transients

Motor drive isolation transformers are manufactured using the same high-quality construction features as our ventilated transformer products, including NEMA 2 enclosures and the 220 °C (Class R) insulation system as standard. Epoxy encapsulated models have NEMA 3R enclosures and 115 °C temperature rise as standard. All Eaton three-phase ventilated motor drive isolation transformers include a normally open dry contact temperature sensor installed in the coils. This sensor can be connected to provide advance alert or warning of a potential overheating of the transformer. Ventilating transformers are typically floor-mounted on an elevated housekeeping pad. When properly supported, they are also suitable for wall mounting or trapeze-mounting from ceilings. Encapsulated designs are typically wall-mounted through 15 kVA; larger designs are floor-mount.

Motor drive isolation transformers are outside the scope of U.S. energy efficiency federal law 10 CFR Part 431. However, motor drive isolation transformers are included in the scope of energy efficiency laws in other countries, such as Canada.

**Technical Data****Available Ratings**

Eaton's motor drive isolation transformers are available in a wide range of ratings to meet specific voltage conversion requirements. Available in three-phase ventilated designs to 1500 hp and 600 V; epoxy encapsulated three-phase designs are available to 20 hp.

**kVA Capacity**

Eaton's motor drive isolation encapsulated and ventilated transformers are available in the same kVA ratings as general purpose encapsulated and ventilated transformers.

**Insulation System and Temperature Rise**

Eaton's motor drive isolation ventilated transformers are manufactured using a 220 °C insulation system with 150 °C temperature rise as standard. 115 °C or 80 °C temperature rise are available as an option. Encapsulated designs use a 180 °C insulation system with 115 °C temperature rise as standard. 80 °C temperature rise is available as an option on encapsulated transformers.

**Frequency**

Most motor drive isolation transformers are designed to operate in 60 Hz systems. 50/60 Hz designs are available as an option. Eaton's transformers can be designed to operate at a variety of frequencies.

**Winding Material**

Aluminum conductor and terminations are provided as standard on ventilated transformers. Copper winding conductors and terminations are available as an option. For encapsulated designs, most models rated 2 kVA and below are constructed using copper windings; 3 kVA and larger designs have aluminum windings as standard, with copper windings available as an option.

**Installation Clearances**

Eaton's ventilated transformers should be installed with minimum clearances as noted on the transformer's nameplate. Most Eaton transformers require a minimum of 6 inches clearance behind the transformer; however, many small kVA ventilated transformers may be installed with just 2 inches clearance, while large kVA transformers require 12 inches or more of clearance behind the transformer. Minimum installation clearances are stated on the nameplate of all transformers. The NEC requires a minimum of 36 inches clearance in front of the transformer. Care should be taken to avoid restricting the airflow through the bottom of the transformer. Transformers should be located in areas not accessible to the public.

**Wiring Compartment**

Eaton's motor drive isolation transformers have wiring compartments sized to comply with NEMA and NEC standards.

**Thermal Sensors**

Eaton's motor drive isolation transformers are provided with thermal sensors imbedded in their coils. The thermal sensors have normally open dry contacts that can be wired to provide a signal to remote locations to indicate a potential heating problem within the transformer coils. Contacts are rated for 180 °C.

## Description

### Hazardous Location Transformers Rated 600 V and Below

#### Applications

Eaton's hazardous location transformers are suitable for use in environments classified by the National Electrical Code (NEC) as Class I, Division 2, Groups A, B, C and D, as defined by NEC Article 501, when installed in compliance with NEC-recommended procedures for dry-type transformers rated 600 V and below.

As defined by NEC Article 500, Class I, Division 2 locations include atmospheres that may contain volatile or ignitable concentrations of flammable liquids or gas vapors, or locations adjacent to such environments. Acetone, ammonia, benzene, gasoline, methane, propane and natural gas are examples of such substances.

Eaton's hazardous location transformers are of the encapsulated design, and are available up to 600 V ratings. Single-phase ratings 0.05–37.5 kVA; three-phase ratings to 112.5 kVA. Hazardous location transformers use a 180 °C insulation system with 115 °C temperature rise.

When provided in a grade 304 or 316 stainless steel enclosure, Eaton's hazardous location transformers meet the corrosion-resistance requirements of a NEMA 3RX enclosure rating. Hazardous location transformers can be mounted in any position indoors, and only in upright positions for outdoor installations. NEMA 4X rated enclosures manufactured using either grade 304 or 316 stainless steel are available as an option.

Encapsulated transformers, including Class I Division 2 transformers, are outside the scope of 10 CFR Part 431 energy efficiency requirements.

#### Technical Data

##### Available Ratings

Eaton's hazardous location transformers are available in the same ratings as sand and resin encapsulated transformers. Hazardous location transformers are available in a wide range of ratings to meet specific customer requirements.

##### kVA Capacity

Single-phase designs are available in ratings from 0.05 kVA through 37.5 kVA; three-phase ratings 3–112.5 kVA.

##### Insulation System and Temperature Rise

Eaton's hazardous location transformers are manufactured using a 180 °C insulation system with 115 °C temperature rise as standard. 80 °C temperature rise is available as an option.

#### Frequency

Most hazardous location transformers are designed to operate in 60 Hz systems. 50/60 Hz designs are available as an option. Eaton's transformers can be designed to operate at a variety of frequencies.

#### Winding Material

Copper conductors and terminations are provided as standard on Eaton's hazardous location transformers rated 2 kVA and less. Aluminum conductor and terminations are provided as standard on hazardous location transformers rated 3 kVA and greater. Copper winding conductors and terminations are available as an option.

#### Installation Clearances

Eaton's wall-mounted hazardous location transformers have a specially designed hanger bracket that spaces the transformer an adequate distance from the mounting surface.

Transformers should be located in areas not accessible to the public.

## Description

**Mini-Power Centers  
Rated 600 V and Below****Applications**

An Eaton mini-power center replaces three individual components:

- Primary main breaker
- Transformer
- Distribution loadcenter

...by combining all three into a single unit. All interconnecting wiring is performed at the factory. Mini-power centers are ideally suited for applications where 120 V is required at a remote location. Parking lots, workbenches and temporary power on construction sites are common applications for mini-power centers. Available with aluminum bus and plug-on branch breakers, or with copper bus and bolt-on branch breakers. Mini-power centers incorporate an encapsulated transformer in their construction. Primary main breakers are available in a variety of interrupting ratings. When provided in a grade 316 stainless steel enclosure, the Eaton mini-power center meets the corrosion-resistance requirements of a NEMA 3RX enclosure rating. Mini-power centers should be mounted in upright positions only for all installations.

Mini-power centers are outside the scope of energy efficiency mandates, including 10 CFR Part 431.

**Technical Data****Available Ratings**

Eaton's mini-power centers are available in single-phase and three-phase ratings to 600 V, 100 A and 30 kVA with secondary loadcenters with provisions for up to 24 single-pole branch breakers. Mini-power centers are available in a wide range of ratings to meet specific voltage conversion requirements.

**kVA Capacity**

Single-phase designs are available in ratings from 3 kVA through 25 kVA; three-phase ratings 15 kVA through 30 kVA.

**Insulation System and Temperature Rise**

Mini-power centers are manufactured using a 180 °C insulation system with 115 °C temperature rise as standard. 80 °C temperature rise is available as an option.

**Frequency**

Most mini-power centers are designed to operate in 60 Hz systems. 50/60 Hz designs are available as an option. Eaton's mini-power centers can be designed to operate at a variety of frequencies.

**Winding Material**

Aluminum conductor and terminations are provided as standard on encapsulated transformers rated 3 kVA and greater. Copper winding conductors and terminations are available as an option. Copper windings are standard in the all-copper model.

**Installation Clearances**

Eaton's mini-power centers are designed to be wall-mounted. They have a specially designed hanger bracket that spaces the mini-power center an adequate distance from the mounting surface.

Mini-power centers should be located in areas not accessible to the public.

**Wiring Compartments**

Eaton's mini-power centers have wiring compartments sized to comply with NEMA and NEC standards. Ample conduit knockouts are provided to offer ready access. The wiring compartment of wall-mounted transformers is located in the bottom portion of the enclosure.

**Primary Main Breakers**

Mini-power centers are provided with primary main circuit breakers that have an interrupting rating of 14 kAIC. EHD primary main circuit breakers are provided as standard on mini-power centers with a 480 V primary; 600 V designs have an FD primary main breaker as standard. Primary main circuit breakers with greater AIC ratings are available as an option on mini-power centers with plug-on secondary circuit breakers.

Optional primary main breakers are FD (rate 25 kAIC at 480 V; 18 kAIC at 600 V), HFD (65 kAIC at 480 V; 25 kAIC at 600 V) or FDC (100 kAIC at 480 V; 35 kAIC at 600 V).

**Branch Circuit Breakers**

Eaton's mini-power centers are available with a tin-plated aluminum bus loadcenter interior that accepts 1-inch plug-on branch circuit breakers Type BR family.

The all-copper mini-power center is constructed with a copper-wound transformer and tin-plated copper bus loadcenter interior that accepts 1-inch bolt-on branch breakers Type BAB family.

Technical Data

## Transformer Selection

### How to Select Single-Phase Units

1. Determine the primary (source) voltage—the voltage presently available.
2. Determine the secondary (load) voltage—the voltage needed at the load.
3. Determine the kVA load:
  - If the load is defined in kVA, a transformer can be selected from the tabulated data.
  - If the load rating is given in amperes, determine the load kVA from the following chart. To determine kVA when volts and amperes are known, use the formula:

$$\text{kVA} = \frac{\text{Volts} \times \text{Amperes}}{1000}$$

—If the load is an AC motor, determine the minimum transformer kVA from **Table 19.1-10** at the right.

—Select a transformer rating equal to or greater than the load kVA.

4. Define tap arrangements needed.
5. Define temperature rise.

**Table 19.1-10. Single-Phase AC Motors**

**Note:** When motor service factor is greater than 1, increase full load amperes proportionally. Example: If service factor is 1.15, increase ampere values by 15%.

Horsepower	Full Load Amperes				Minimum Transformer kVA <sup>①</sup>
	115 Volts	208 Volts	220 Volts	230 Volts	
1/6	4.4	2.4	2.3	2.2	0.53
1/4	5.8	3.2	3.0	2.9	0.70
1/3	7.2	4.0	3.8	3.6	0.87
1/2	9.8	5.4	5.1	4.9	1.18
3/4	13.8	7.6	7.2	6.9	1.66
1	16	8.8	8.4	8	1.92
1-1/2	20	11.0	10.4	10	2.40
2	24	13.2	12.5	12	2.88
3	34	18.7	17.8	17	4.10
5	56	30.8	29.3	28	6.72
7-1/2	80	44	42	40	9.6
10	100	55	52	50	12.0

<sup>①</sup> If motors are started more than once per hour, increase minimum transformer kVA by 20%.

**Table 19.1-11. Full Load Current in Amperes—Single-Phase Circuits <sup>②</sup>**

kVA	Voltage								
	120	208	220	240	277	480	600	2400	4160
0.25	2.0	1.2	1.1	1.0	0.9	0.5	0.4	0.10	0.06
0.50	4.2	2.4	2.3	2.1	1.8	1.0	0.8	0.21	0.12
0.75	6.3	3.6	3.4	3.1	2.7	1.6	1.3	0.31	0.18
1	8.3	4.8	4.5	4.2	3.6	2.1	1.7	0.42	0.24
1.5	12.5	7.2	6.8	6.2	5.4	3.1	2.5	0.63	0.36
2	16.7	9.6	9.1	8.3	7.2	4.2	3.3	0.83	0.48
3	25	14.4	13.6	12.5	10.8	6.2	5.0	1.2	0.72
5	41	24.0	22.7	20.8	18.0	10.4	8.3	2.1	1.2
7.5	62	36	34	31	27	15.6	12.5	3.1	1.8
10	83	48	45	41	36	20.8	16.7	4.2	2.4
15	125	72	68	62	54	31	25	6.2	3.6
25	208	120	114	104	90	52	41	10.4	6.0
37.5	312	180	170	156	135	78	62	15.6	9.0
50	416	240	227	208	180	104	83	20.8	12.0
75	625	360	341	312	270	156	125	31.3	18.0
100	833	480	455	416	361	208	166	41.7	24.0
167	1391	802	759	695	602	347	278	69.6	40.1

<sup>②</sup> Table of standard transformer ratings used to power single-phase motors in **Table 19.1-10**.



**Technical Data**

**Three-Phase Transformers**

**How to Select Three-Phase Units**

1. Determine the primary (source) voltage—the voltage presently available.
2. Determine the secondary (load) voltage—the voltage needed at the load.
3. Determine the kVA load:  
—If the load is defined in kVA, a transformer can be selected from the tabulated data.  
  
—If the load rating is given in amperes, determine the load kVA from the following chart. To determine kVA when volts and amperes are known, use the formula:

$$\text{kVA} = \frac{\text{Volts} \times \text{Amperes} \times 1.732}{1000}$$

- If the load is an AC motor, determine the minimum transformer kVA from **Table 19.1-12** at the right.
  - Select a transformer rating equal to or greater than the load kVA.
4. Define tap arrangements needed.
  5. Define temperature rise.

Using the above procedure, select the transformer from the listings in this catalog.

**Table 19.1-12. Three-Phase AC Motors**

Horsepower	Full Load Amperes					Minimum Transformer kVA ①
	208 Volts	230 Volts	380 Volts	460 Volts	575 Volts	
1/2	2.2	2.0	1.2	1.0	0.8	0.9
3/4	3.1	2.8	1.7	1.4	1.1	1.2
1	4.0	3.6	2.2	1.8	1.4	1.5
1-1/2	5.7	5.2	3.1	2.6	2.1	2.1
2	7.5	6.8	4.1	3.4	2.7	2.7
3	10.7	9.6	5.8	4.8	3.9	3.8
5	16.7	15.2	9.2	7.6	6.1	6.3
7-1/2	24	22	14	11	9	9.2
10	31	28	17	14	11	11.2
15	46	42	26	21	17	16.6
20	59	54	33	27	22	21.6
25	75	68	41	34	27	26.6
30	88	80	48	40	32	32.4
40	114	104	63	52	41	43.2
50	143	130	79	65	52	52
60	170	154	93	77	62	64
75	211	192	116	96	77	80
100	273	248	150	124	99	103
125	342	312	189	156	125	130
150	396	360	218	180	144	150
200	528	480	291	240	192	200

① If motors are started more than once per hour, increase minimum transformer kVA by 20%.  
**Note:** When motor service factor is greater than 1, increase full load amperes proportionally. Example: If service factor is 1.15, increase above ampere values by 15%.

**Table 19.1-13. Full Load Current in Amperes—Three-Phase Circuits**

kVA	Voltage						
	208	240	380	480	600	2400	4160
3	8.3	7.2	4.6	3.6	2.9	0.72	0.42
6	16.6	14.4	9.1	7.2	5.8	1.4	0.83
9	25	21.6	13.7	10.8	8.6	2.2	1.2
15	41.7	36.1	22.8	18.0	14.4	3.6	2.1
22.5	62.4	54.1	34.2	27.1	21.6	5.4	3.1
30	83.4	72.3	45.6	36.1	28.9	7.2	4.2
37.5	104	90.3	57.0	45.2	36.1	9.0	5.2
45	124	108	68.4	54.2	43.4	10.8	6.3
50	139	120	76	60.1	48.1	12.0	6.9
75	208	180	114	90	72	18.0	10.4
112.5	312	270	171	135	108	27.1	15.6
150	416	360	228	180	144	36.1	20.8
225	624	541	342	270	216	54.2	31.3
300	832	721	456	360	288	72.2	41.6
500	1387	1202	760	601	481	120	69.4
750	2084	1806	1140	903	723	180	104
1000	2779	2408	1519	1204	963	241	139

## Technical Data

**Table 19.1-14. Typical Data for Encapsulated 480 V Class General-Purpose Dry-Type Transformers, Aluminum Wound**

kVA	Frame	Weight Lbs		Losses in Watts		Efficiency				% Regulation		% Impedance ①		Sound Level dB
		Al	Cu	No Load	Total	1/4 Load	1/2 Load	3/4 Load	Full Load	100% P.F.	80% P.F.	Min.	Max.	
<b>Type EP 115 °C Rise Single-Phase</b>														
0.05	FR52	—	7	6	9	65.3	79.6	84.3	85.6	5.9	6.4	5.5	9.5	45
0.075	FR54	—	7	7	14	66.0	79.0	82.5	82.8	9.4	9.2	7.5	11.0	45
0.10	FR54	—	7	5	15	82.4	86.9	87.7	86.5	10.3	10.6	8.0	12.0	45
0.15	FR55	—	8	7	20	83.4	88.2	88.9	87.8	9.0	9.6	8.0	12.0	45
0.25	FR57P	—	12	14	29	79.0	87.2	89.5	89.6	5.9	7.5	7.5	9.5	45
0.5	FR57P	—	14	20	47	85.1	90.3	91.4	91.4	5.5	7.0	5.0	7.0	45
0.75	FR58AP	—	22	29	57	86.0	91.3	92.7	92.9	3.9	5.0	4.0	6.0	45
1	FR67P	—	25	24	60	90.8	93.9	94.5	94.4	3.8	4.9	3.8	5.8	45
1.5	FR67P	31	31	30	90	92.5	94.7	95.0	94.6	4.1	5.2	2.5	4.5	45
2	FR68P	40	40	30	100	94.2	95.7	95.8	95.4	3.6	4.7	3.3	5.3	45
3	FR176	64	69	61	135	92.0	95.0	95.7	95.7	2.5	3.5	2.5	4.1	45
5	FR177	107	120	104	215	91.8	95.0	95.8	95.9	2.3	3.3	2.0	4.6	45
7.5	FR178	123	133	129	250	93.2	96.0	96.7	95.9	1.5	2.4	2.4	3.4	45
10	FR179	193	208	153	295	93.9	96.3	97.0	97.2	1.5	2.5	2.0	3.3	50
15	FR180	216	235	209	435	94.4	96.6	97.1	97.2	1.6	2.8	1.6	3.6	50
25	FR182	385	414	191	440	96.8	98.0	98.3	98.4	1.1	2.5	1.6	4.2	50
37.5	FR300A	735	856	225	370	97.4	98.3	98.5	98.4	1.2	2.6	2.8	4.0	50
<b>Type EPT 115 °C Rise Three-Phase ②</b>														
3	FR201	116	123	110	165	87.3	92.6	94.3	94.9	2.1	6.1	2.4	8.0	45
6	FR200	143	153	145	275	90.9	94.5	95.5	95.7	2.2	3.1	2.9	4.9	45
9	FR103	166	178	195	375	91.6	95.0	95.9	96.1	2.0	2.8	2.0	3.6	45
15	FR95	275	300	265	545	93.0	95.7	96.5	96.6	1.9	3.1	1.9	3.9	50
30	FR243	422	504	250	665	96.5	97.7	98.0	97.9	1.5	2.5	1.8	3.8	50
45	FR244	660	745	300	740	97.2	98.2	98.4	98.5	1.0	2.1	1.8	4.0	50
75	FR245	1275	1450	400	945	97.7	98.6	98.8	98.8	0.8	1.6	1.7	3.4	55

 ① Actual impedance may vary  $\pm 7.5\%$ .

② Type EPT transformers 3–15 kVA are T-T connected.

**Note:** Performance data is based upon 480 V delta primary and a 208Y/120 V secondary for three-phase transformers; 240 x 480 V primary and a 120/240 V secondary for single-phase transformers. Refer to Eaton for 5 kV class information. All data is subject to future revision.

**Technical Data**

**Table 19.1-15. Typical Data for 480 V Class DOE 2016 Efficient Dry-Type Transformers, Aluminum Wound ①**

kVA	Frame	Weight	Losses in Watts		Efficiency (T Rise +20 °C)				% Regulation		% Imp. T Rise +20 °C	X T Rise +20 °C	R T Rise +20 °C	Sound Level dB (per NEMA ST-20)	Efficiency at 35% Load 75 °C	Inrush Practical Max.
			No Load	Total at Rise +20 °C	25%	50%	75%	Full Load	100% PF	80% PF						

**Type DS-3 150 °C Rise DOE 2016 Efficient Single-Phase**

15	816	246	80	549	97.6	97.6	97.2	96.6	2.0	2.9	4.3	3.0	3.1	45	97.70	245
25	818	359	300	848	97.7	98.1	97.9	97.5	1.4	2.7	3.5	2.8	2.2	45	98.00	379
37.5	818	374	125	1314	98.1	97.8	97.2	96.6	2.2	4.6	5.8	4.8	3.2	45	98.20	355
50	819	555	300	1668	98.2	98.1	97.6	97.0	1.9	4.0	5.1	4.3	2.7	45	98.30	528
75	820	740	170	2266	98.4	98.2	97.6	97.0	2.3	5.3	6.9	6.3	2.8	50	98.50	701
100	821	841	260	2543	98.5	98.4	98.0	97.6	1.9	4.7	6.1	5.6	2.3	50	98.60	944
167	814	1610	900	3987	68.7	98.7	98.4	98.0	1.4	6.8	9.7	9.5	1.8	55	98.70	416

**Type DS-3 115 °C Rise DOE 2016 Efficient Single-Phase**

15	816	246	80	519	97.8	97.8	97.3	96.8	2.1	3.1	3.9	2.6	2.9	45	97.70	244
25	818	373	300	766	97.7	98.1	98.0	97.7	1.4	2.8	3.3	2.8	1.9	45	98.00	367
37.5	818	380	125	1182	98.2	98.4	98.1	97.8	2.0	3.1	4.1	2.9	2.8	45	98.20	205
50	819	590	300	417	98.4	98.3	97.9	97.4	1.8	4.1	5.2	5.2	0.2	45	98.30	511
75	820	689	170	2356	98.5	98.2	97.6	97.0	2.7	5.6	6.9	6.3	2.9	50	98.50	572

**Type DS-3 80 °C Rise DOE 2016 Efficient Single-Phase**

15	818	360	115	269	97.4	98.3	98.4	98.4	0.8	1.7	2.0	1.8	1.0	45	97.70	460
25	818	370	120	580	97.8	98.2	98.0	97.8	1.5	3.2	3.9	3.4 ①	1.8	45	98.00	348
37.5	819	565	150	834	98.1	98.4	98.1	97.8	1.5	3.3	4.1	3.6	1.8	45	98.20	490
50	820	680	175	1014	98.4	98.5	98.4	98.1	1.5	3.4	4.2	3.9	1.7	45	98.30	577
75	821	900	260	1387	98.3	98.6	98.5	98.2	1.4	3.5	4.3	4.0	1.5	50	98.50	807

**Type DT-3 150 °C Rise DOE 2016 Efficient**

15	939	225	64	517	97.5	97.5	96.9	96.3	3.41	4.04	3.74	2.08	3.46	45	97.89	70
30	940	409	121	689	97.9	98.1	97.8	97.4	2.25	2.49	2.74	1.13	2.25	45	98.23	218
45	940	416	125	1220	98.2	98.1	97.7	97.1	2.64	3.74	3.51	2.64	2.67	45	98.40	165
75	942	570	193	1761	98.4	98.3	97.9	97.5	2.26	3.86	3.61	3.34	2.29	50	98.60	270
112.5	943	976	256	2306	98.6	98.6	98.2	97.8	1.94	4.14	4.37	4.22	1.99	50	98.74	302
150	943	1239	350	2560	98.7	98.7	98.4	98.1	1.60	3.16	3.46	3.09	1.61	50	98.83	516
225	944	1571	489	3289	98.8	98.9	98.6	98.4	1.36	3.51	4.29	3.96	1.39	55	98.94	721
300	945	2157	592	4178	98.9	98.9	98.7	98.4	1.29	3.63	4.45	4.26	1.32	55	99.02	731

**Type DT-3 115 °C Rise DOE 2016 Efficient**

15	939	231	64	472	97.6	97.6	97.2	96.6	3.10	3.78	3.54	2.08	3.14	45	97.89	70
30	940	399	121	586	97.9	98.3	98.0	97.7	1.91	2.35	2.21	1.37	1.90	45	98.23	196
45	940	429	125	1156	98.3	98.2	97.8	97.2	2.49	4.10	3.81	3.44	2.52	45	98.40	146
75	942	605	193	1655	98.4	98.4	98.0	97.6	2.11	4.07	3.82	3.90	2.14	50	98.60	244
112.5	943	982	256	2236	98.6	98.6	98.2	97.8	1.86	4.43	4.53	4.81	1.89	50	98.74	265
150	943	1253	350	2400	98.7	98.8	98.5	98.2	1.48	3.37	3.97	3.59	1.49	50	98.83	447
225	944	1607	489	3092	98.8	98.9	98.7	98.4	1.26	3.89	5.30	4.73	1.28	55	98.94	610
300	945	2193	592	3874	98.9	99.0	98.8	98.5	1.18	3.77	4.52	4.65	1.21	55	99.02	675

**Type DT-3 80 °C Rise DOE 2016 Efficient**

15	939	237	65	508	98.0	97.9	97.4	96.8	3.63	3.81	3.81	2.40	2.96	45	97.89	70
30	940	436	125	452	98.0	98.4	98.3	98.1	1.45	2.49	2.50	1.76	1.78	45	98.23	165
45	942	570	193	531	98.0	98.6	98.6	98.4	1.12	2.31	3.61	2.01	1.37	50	98.40	270
75	943	970	256	865	98.4	98.8	98.7	98.5	1.06	2.76	3.11	2.81	1.32	50	98.60	302
112.5	943	1274	350	1220	98.5	98.9	98.8	98.6	0.99	2.37	2.62	2.31	1.21	50	98.74	516
150	944	1628	489	1244	98.5	98.9	99.0	98.9	0.74	2.34	2.90	2.64	0.93	55	98.83	721
225	945	2157	592	1999	98.7	99.0	99.0	98.9	0.80	2.73	3.35	3.20	0.99	55	98.94	731

① Typical values for aluminum windings. Refer to Page 19.1-23 for typical data for copper windings. Up-to-date design data is available at [www.eaton.com](http://www.eaton.com).

**Note:** Performance data is based upon 480 V delta primary and a 208Y/120 V secondary for three-phase transformers; 240 x 480 V primary and a 120/240 V secondary for single-phase transformers. Refer to Eaton for 5 kV class information. All data is subject to future revision.

## Technical Data

**Table 19.1-16. Typical Data for 480 V Class K-Factor Rated DOE 2016 Efficient Dry-Type Transformers, Aluminum Wound ①**

kVA	Frame	Weight	Losses in Watts		Efficiency (T Rise +20 °C)				% Regulation		% Imp. T Rise +20 °C	X T Rise +20 °C	R T Rise +20 °C	Sound Level dB (per NEMA ST-20)	Efficiency at 35% Load 75 °C	Inrush Practical Max.
			No Load	Total at Rise +20 °C	25%	50%	75%	Full Load	100% PF	80% PF						
<b>Type KT-4 K-Factor 4, 150 °C Rise DOE 2016 Efficient</b>																
15	939	228	64	517	97.5	97.5	96.9	96.3	3.4	3.9	3.9	2.1	3.3	45	97.89	70
30	940	437	121	641	97.9	98.2	97.9	97.5	2.1	2.5	2.7	1.4	2.1	45	98.23	196
45	940	438	125	1262	98.2	98.1	97.6	97.0	2.7	4.3	4.4	3.4	2.8	45	98.40	146
75	942	599	193	1803	98.4	98.3	97.9	97.4	2.3	4.2	4.1	3.9	2.3	50	98.60	244
112.5	943	978	256	2427	98.6	98.5	98.1	97.7	2.0	4.6	5.2	4.8	2.1	50	98.74	265
150	943	1237	350	2601	98.7	98.7	98.4	98.1	1.6	3.5	3.9	3.6	1.6	50	98.83	447
225	944	1607	489	3344	98.8	98.8	98.6	98.3	1.4	3.9	5.4	4.7	1.4	55	98.94	610
300	945	2193	592	4189	98.9	98.9	98.7	98.4	1.3	3.9	4.8	4.7	1.4	55	99.02	675
<b>Type KT-4 K-Factor 4, 115 °C Rise DOE 2016 Efficient</b>																
15	940	402	91	294	97.5	98.2	98.3	98.1	1.6	1.7	1.7	1.0	1.4	45	97.89	136
30	940	413	121	586	97.9	98.3	98.0	97.7	1.9	2.4	2.3	1.4	1.9	45	98.23	196
45	942	612	193	596	98.0	98.5	98.5	98.3	1.3	2.4	2.7	2.3	1.3	50	98.40	244
75	943	978	256	994	98.3	98.7	98.6	98.4	1.2	3.0	3.5	3.2	1.3	50	98.60	265
112.5	943	1237	350	1350	98.5	98.8	98.7	98.1	1.1	2.5	2.9	2.7	1.1	50	98.74	447
150	944	1607	489	1374	98.5	98.9	98.9	98.8	0.8	2.6	3.3	3.2	0.9	55	98.83	610
225	945	2193	592	2179	98.7	99.0	98.9	98.8	0.9	2.8	3.6	3.5	0.9	55	98.94	675
<b>Type KT-4 K-Factor 4, 80 °C Rise DOE 2016 Efficient</b>																
15	939	254	65	543	97.7	97.7	97.2	96.6	3.6	3.7	3.7	1.8	3.2	45	97.89	58
30	940	438	125	467	98.0	98.4	98.3	98.1	1.5	2.7	2.8	2.3	1.7	45	98.23	146
45	942	619	193	543	98.0	98.6	98.5	98.4	1.1	2.4	2.4	2.3	1.3	50	98.40	244
75	943	978	256	910	98.4	98.7	98.7	98.5	1.1	3.0	3.5	3.2	1.3	50	98.60	265
112.5	944	1607	489	711	98.1	98.8	99.0	98.9	0.6	1.9	2.5	2.4	0.6	55	98.74	610
150	944	1607	489	1264	98.5	98.9	98.9	98.8	0.8	2.6	3.3	3.2	0.9	55	98.83	610
<b>Type KT-13 K-Factor 13, 150 °C Rise DOE 2016 Efficient</b>																
15	939	228	64	517	97.5	97.5	96.9	96.3	3.41	3.9	3.9	2.1	3.2	45	97.89	70
30	940	395	121	641	97.9	98.2	97.9	97.2	2.10	2.5	2.5	1.4	2.1	45	98.23	196
45	942	594	193	649	98.0	98.5	98.4	98.2	1.39	2.4	2.8	2.3	1.3	53	98.40	244
75	943	1012	256	1078	98.3	98.6	98.5	98.3	1.36	3.0	3.5	3.2	1.3	53	98.60	265
112.5	943	1297	350	1463	98.5	98.7	98.6	98.1	1.22	2.5	3.2	2.7	1.1	53	98.74	447
150	944	1607	489	1486	98.5	98.9	98.8	98.0	0.92	2.6	3.3	3.2	0.9	58	98.83	610
225	945	2193	592	2356	98.7	99.0	98.9	98.1	0.97	2.8	3.8	3.5	0.9	58	98.94	675
<b>Type KT-13 K-Factor 13, 115 °C Rise DOE 2016 Efficient</b>																
15	940	412	91	294	97.2	98.0	97.9	97.5	1.1	1.4	1.6	0.3	0.4	45	97.89	137
30	940	413	121	586	97.9	98.3	98.0	97.7	1.9	2.4	2.3	1.4	1.9	45	98.23	196
45	942	612	193	596	98.0	98.5	98.5	98.3	1.3	2.4	2.7	2.3	1.3	53	98.40	244
75	943	978	256	994	98.3	98.7	98.6	98.4	1.2	3.0	3.5	3.2	1.3	53	98.60	265
112.5	944	1607	489	773	98.1	98.8	98.9	98.9	0.6	1.9	2.5	2.4	0.6	58	98.74	610
150	944	1607	489	1374	98.5	98.9	99.0	98.8	0.8	2.6	3.3	3.2	0.9	58	98.83	610
<b>Type KT-13 K-Factor 13, 80 °C Rise DOE 2016 Efficient</b>																
15	—	—	—	—	—	—	—	—	—	—	—	—	—	45	97.89	—
30	942	612	193	241	97.3	98.3	98.6	98.6	0.8	1.6	1.8	1.6	0.9	53	98.23	244
45	942	612	193	543	98.0	98.6	98.5	98.4	1.1	2.4	2.7	2.3	1.3	53	98.40	244
75	943	1237	350	551	98.0	98.7	98.8	98.8	0.7	1.7	2.0	1.8	0.8	53	98.60	447
112.5	944	1607	489	711	98.1	98.8	99.0	98.9	0.6	1.9	2.5	2.4	0.6	58	98.74	610
150	945	2193	592	891	98.3	98.9	99.0	99.0	0.5	1.9	2.4	2.3	0.6	58	98.83	675

① Typical values for aluminum windings. Refer to Page 19.1-24 for typical data for copper windings. Up-to-date design data is available at [www.eaton.com](http://www.eaton.com).

**Note:** Performance data is based upon 480 V delta primary and a 208Y/120 V secondary for three-phase transformers; 240 x 480 V primary and a 120/240 V secondary for single-phase transformers. Refer to Eaton for 5 kV class information. All data is subject to future revision.

**Technical Data**

**Table 19.1-17. Typical Data for 480 V Class DOE 2016 Efficient Dry-Type Transformers, Copper Wound ①**

kVA	Frame	Weight	Losses in Watts		Efficiency (T Rise +20 °C)				% Regulation		% Imp. T Rise +20 °C	X T Rise +20 °C	R T Rise +20 °C	Sound Level dB (per NEMA ST-20)	Efficiency at 35% Load 75 °C	Inrush Practical Max.
			No Load	Total at Rise +20 °C	25%	50%	75%	Full Load	100% PF	80% PF						
<b>Type DS-3 150 °C Rise DOE 2016 Efficient Single-Phase</b>																
15	816	270	80	605	97.6	97.5	96.9	96.3	3.5	4.2	4.2	2.3	3.5	45	97.70	183
25	818	406	115	732	97.9	98.1	97.7	97.3	—	—	3.5	2.5	2.5	45	98.00	459
37.5	818	453	125	1154	98.2	98.1	97.6	97.0	2.7	3.7	4.8	4.0	2.7	45	98.20	440
50	819	657	160	1159	98.3	98.4	98.1	97.7	2.0	3.3	3.8	3.8	2.0	45	98.30	440
75	820	803	175	2259	98.5	98.3	97.7	97.1	2.8	4.8	6.5	5.8	2.8	50	98.50	711
100	821	960	250	2504	98.6	98.4	98.0	97.5	2.3	4.3	5.5	5.0	2.3	50	98.60	926
167	814	1665	570	3094	98.7	98.8	98.6	98.3	1.5	6.3	9.0	8.8	1.5	50	98.70	955
<b>Type DS-3 115 °C Rise DOE 2016 Efficient Single-Phase</b>																
15	816	264	80	437	97.8	98.1	97.8	97.3	2.4	2.2	3.3	2.2	2.4	45	97.70	239
25	818	420	110	603	97.9	98.2	98.0	97.7	2.0	2.9	3.2	2.6	2.0	45	98.00	287
37.5	818	450	125	1217	98.2	98.0	97.5	96.9	2.9	4.5	5.9	5.1	2.9	45	98.20	433
50	819	703	300	1409	98.4	98.4	98.0	97.6	2.2	3.8	4.7	4.1	2.2	—	98.30	499
75	820	793	175	2178	98.5	98.3	97.8	97.2	2.7	4.7	6.2	5.6	2.7	50	98.50	702
<b>Type DS-3 80 °C Rise DOE 2016 Efficient Single-Phase</b>																
15	818	407	115	293	97.3	98.2	98.3	98.2	1.2	1.7	1.8	1.4	1.2	45	97.70	125
25	818	430	300	679	97.9	98.4	98.3	98.1	1.5	2.6	3.0	2.6	1.5	45	98.00	164
37.5	819	685	300	729	98.1	98.6	98.6	98.5	1.1	2.2	2.6	2.3	1.1	45	98.20	205
50	820	799	180	1013	98.3	98.6	98.4	98.1	1.7	2.9	3.4	2.9	1.7	45	98.30	329
75	821	1042	250	1447	98.3	98.6	98.4	98.1	1.6	3.4	3.8	3.5	1.6	50	98.50	338
<b>Type DT-3 150 °C Rise DOE 2016 Efficient</b>																
15	939	250	73	401	97.5	97.7	97.4	96.9	2.6	3.1	2.9	1.6	2.7	45	97.89	109
30	940	415	114	732	97.9	98.1	97.7	97.3	2.4	2.4	2.6	0.8	2.4	45	98.23	262
45	940	478	118	1271	98.3	98.1	97.6	97.0	2.8	3.8	3.4	2.6	2.8	45	98.4	181
75	942	676	206	1615	98.4	98.4	98.1	97.6	2.1	2.8	3.2	1.9	2.1	50	98.6	399
112.5	943	1263	251	2223	98.6	98.6	98.3	97.9	1.9	3.4	3.6	3.1	1.9	50	98.74	351
150	943	1410	350	2351	98.7	98.8	98.5	98.2	1.5	2.8	3.4	2.6	1.5	50	98.83	597
225	944	1745	418	4103	98.8	98.7	98.4	98.0	1.7	3.8	4.3	4.0	1.3	55	98.94	540
300	945	2354	561	4491	99.0	98.9	98.7	98.3	1.4	3.0	3.5	3.2	1.4	55	99.02	858
<b>Type DT-3 115 °C Rise DOE 2016 Efficient</b>																
15	939	241	73	367	97.5	97.9	97.6	97.2	2.4	2.9	2.8	1.6	2.4	45	97.89	109
30	940	433	114	658	98.0	98.2	97.0	97.5	2.1	2.3	2.3	1.0	2.1	45	98.23	235
45	940	471	118	1189	98.3	98.2	97.7	97.2	2.6	3.8	3.5	2.9	2.6	45	98.4	170
75	942	665	206	1508	98.4	98.5	98.2	97.8	1.9	2.8	3.0	2.1	1.9	50	98.6	378
112.5	943	1271	251	2163	98.7	98.6	98.3	97.9	1.8	3.6	4.0	3.6	1.8	50	98.74	307
150	943	1422	350	2234	98.7	98.8	98.4	98.3	1.4	2.9	3.6	3.1	1.4	50	98.83	546
225	944	1857	418	3811	98.9	98.8	98.5	98.2	1.6	4.2	5.0	4.8	1.6	55	98.94	455
300	945	2478	561	4198	98.9	98.9	98.7	98.4	1.3	3.4	4.1	3.9	1.3	55	99.02	707
<b>Type DT-3 80 °C Rise DOE 2016 Efficient</b>																
15	939	239	60	352	97.9	98.2	97.9	97.3	2.2	3.1	2.6	2.1	2.2	45	97.89	92
30	940	466	118	473	98.1	98.5	98.3	98.1	1.5	2.5	2.1	1.7	1.9	45	98.23	181
45	942	667	206	489	97.9	98.6	98.6	98.5	1.0	1.7	2.0	1.2	1.3	50	98.4	399
75	943	1147	251	838	98.4	98.8	98.7	98.6	1.0	2.3	2.7	2.1	1.3	50	98.6	351
112.5	943	1328	350	1125	98.3	98.9	98.9	98.7	0.9	2.1	2.3	2.0	1.1	50	98.74	597
150	944	1745	418	1559	98.6	98.9	98.9	98.7	0.9	2.5	2.9	2.7	1.2	55	98.83	540
225	945	2478	561	2178	98.8	99.0	99.0	98.8	0.9	2.6	3.1	3.0	1.0	55	98.94	707

① Typical values for copper windings. Refer to Page 19.1-21 for typical data for aluminum windings. Up-to-date design data is available at [www.eaton.com](http://www.eaton.com).

**Note:** Performance data is based upon 480 V delta primary and a 208Y/120 V secondary for three-phase transformers; 240 x 480 V primary and a 120/240 V secondary for single-phase transformers. Refer to Eaton for 5 kV class information. All data is subject to future revision.

## Technical Data

**Table 19.1-18. Typical Data for 480 V Class K-Factor Rated DOE 2016 Efficient Dry-Type Transformers, Copper Wound <sup>①</sup>**

kVA	Frame	Weight	Losses in Watts		Efficiency (T Rise +20 °C)				% Regulation		% Imp. T Rise +20 °C	X T Rise +20 °C	R T Rise +20 °C	Sound Level dB (per NEMA ST-20)	Efficiency at 35% Load 75 °C	Inrush Practical Max.
			No Load	Total at Rise +20 °C	25%	50%	75%	Full Load	100% PF	80% PF						

**Type KT-4 K-Factor 4, 150 °C Rise DOE 2016 Efficient**

15	940	418	86	351	97.6	98.2	98.1	97.8	1.9	1.88	1.9	0.7	1.8	45	97.89	154
30	940	458	118	575	98.0	98.3	98.1	97.7	1.9	2.5	2.4	1.9	1.7	45	98.23	170
45	942	677	206	590	97.9	98.5	98.4	98.3	1.3	1.7	1.9	1.3	1.2	50	98.4	378
75	943	1099	251	1041	98.3	98.7	98.5	98.3	1.3	2.4	2.7	2.4	1.2	50	98.6	307
112.5	943	1337	350	1359	98.5	98.8	98.7	98.5	1.1	2.2	2.5	2.3	1.0	50	98.74	546
150	944	1857	418	1828	98.6	98.9	98.7	98.5	1.1	2.8	3.4	3.2	1.1	55	98.83	455
225	945	2478	561	2548	98.7	99.0	98.8	98.6	1.1	2.6	3.1	3.0	1.0	55	98.94	707

**Type KT-4 K-Factor 4, 115 °C Rise DOE 2016 Efficient**

15	940	414	86	338	97.5	98.1	98.1	97.8	1.9	2.0	2.0	1.1	1.7	45	97.89	154
30	940	417	118	528	98.0	98.4	98.2	97.9	1.7	2.53	2.5	1.9	1.7	45	98.23	170
45	942	684	206	543	97.9	98.5	98.5	98.4	1.2	1.69	1.7	1.3	1.2	50	98.4	378
75	943	1083	251	961	98.4	98.7	98.6	98.4	1.2	2.42	2.2	2.4	1.2	50	98.6	307
112.5	943	1337	350	1257	98.5	98.8	98.8	98.6	1.0	2.20	2.5	2.3	1.0	50	98.74	546
150	944	1857	418	1694	98.6	98.9	98.8	98.6	1.0	2.77	3.4	3.2	1.1	55	98.83	455
225	945	2478	561	2361	98.8	99.0	98.9	98.7	1.0	2.56	3.1	3.0	1.0	55	98.94	707

**Type KT-4 K-Factor 4, 80 °C Rise DOE 2016 Efficient**

15	—	—	—	—	—	—	—	—	—	—	—	—	—	45	97.89	—
30	940	475	118	482	98.1	98.4	98.3	98.0	1.5	2.5	2.6	1.9	1.7	45	98.23	170
45	942	678	206	496	97.9	98.6	98.6	98.5	1.0	1.7	1.7	1.3	1.2	50	98.4	378
75	943	1099	251	883	98.4	98.8	98.7	98.5	1.1	2.4	2.7	2.4	1.2	50	98.6	307
112.5	943	1337	350	1156	98.5	98.9	98.8	98.7	0.9	2.2	2.5	2.3	1.0	50	98.74	546
150	944	1857	418	1563	98.6	98.9	98.9	98.7	0.9	2.8	3.4	3.2	1.1	55	98.83	455
225	945	2478	561	2178	98.8	99.0	99.0	98.8	0.9	2.6	3.1	3.0	1.0	55	98.94	707

**Type KT-13 K-Factor 13, 150 °C Rise DOE 2016 Efficient**

15	940	430	116	306	97.5	98.3	98.3	98.2	1.4	1.5	1.5	0.8	1.3	45	97.89	235
30	940	475	118	575	98.0	98.3	98.1	97.7	1.8	2.5	2.6	1.9	1.7	48	98.23	170
45	942	678	206	590	97.9	98.5	98.4	98.3	1.3	1.7	1.7	1.3	1.2	53	98.4	378
75	943	1099	251	1041	98.3	98.7	98.5	98.3	1.3	2.4	2.7	2.4	1.2	53	98.6	307
112.5	943	1337	350	1359	98.5	98.8	98.7	98.5	1.1	2.2	2.5	2.3	1.0	53	98.74	546
150	944	1857	418	1828	98.6	98.9	98.7	98.5	1.1	2.8	3.4	3.2	1.1	58	98.83	455
225	945	2628	561	3130	98.8	99.0	99.0	98.7	1.1	3.5	3.6	3.5	1.1	58	98.94	707

**Type KT-13 K-Factor 13, 115 °C Rise DOE 2016 Efficient**

15	940	398	116	289	97.7	98.4	98.5	98.4	1.4	1.5	1.5	1.0	1.2	45	97.89	235
30	940	475	118	528	98.0	98.4	98.2	97.9	1.7	2.5	2.6	1.9	1.7	48	98.23	170
45	942	658	206	543	97.9	98.5	98.5	98.4	1.2	1.7	1.9	1.3	1.2	53	98.4	378
75	943	1115	251	961	98.4	98.7	98.6	98.4	1.2	2.4	2.8	2.4	1.2	53	98.6	307
112.5	944	2150	337	1589	98.6	98.9	98.8	98.6	3.1	3.5	3.7	3.5	1.1	58	98.74	315
150	944	1857	418	1694	98.6	98.9	98.8	98.6	1.0	2.8	3.4	3.2	1.1	58	98.83	455
225	945	3043	695	2226	98.8	99.1	99.2	99.1	2.9	3.4	3.6	3.5	0.7	58	98.94	—

**Type KT-13 K-Factor 13, 80 °C Rise DOE 2016 Efficient**

15	940	434	116	263	97.7	98.5	98.6	98.5	1.1	1.2	1.2	0.6	1.0	45	97.89	235
30	940	475	118	482	98.1	98.4	98.3	98.0	1.5	2.5	2.6	1.9	1.7	48	98.23	170
45	942	678	206	496	97.9	98.6	98.4	98.5	1.0	1.7	1.7	1.3	1.2	53	98.4	378
75	943	1099	251	883	98.4	98.8	98.7	98.5	1.1	2.4	2.7	2.4	1.2	53	98.6	307
112.5	—	—	—	—	—	—	—	—	—	—	—	—	—	53	98.74	—
150	—	—	—	—	—	—	—	—	—	—	—	—	—	53	98.83	—
225	—	—	—	—	—	—	—	—	—	—	—	—	—	58	98.94	—

<sup>①</sup> Typical values for copper windings. Refer to **Page 19.1-27** for typical data for aluminum windings. Up-to-date design data is available at [www.eaton.com](http://www.eaton.com).

**Note:** Performance data is based upon 480 V delta primary and a 208Y/120 V secondary for three-phase transformers; 240 x 480 V primary and a 120/240 V secondary for single-phase transformers. Refer to Eaton for 5 kV class information. All data is subject to future revision.







Technical Data

Table 19.1-21. Typical Data for 480 V Class NEMA TP-1 Dry-Type Transformers, Copper Wound ①

kVA	Frame	Weight	Losses in Watts		Efficiency (T Rise +20 °C)				% Regulation		% Imp. T Rise +20 °C ②	X T Rise +20 °C	R T Rise +20 °C	Sound Level dB	TP1 Efficiency	Inrush Practical Max.
			No Load	Total at Rise +20 °C	25%	50%	75%	Full Load	100% PF	80% PF						
<b>Type DS-3 150 °C Rise NEMA TP-1 Efficient Single-Phase</b>																
15	816	270	80	605	97.6	97.5	96.9	96.3	3.5	4.2	4.2	2.3	3.5	45	97.70	183
25	818	406	115	732	97.9	98.1	97.7	97.3	—	—	3.5	2.5	2.5	45	98.00	459
37.5	818	453	125	1154	98.2	98.1	97.6	97.0	2.7	3.7	4.8	4.0	2.7	45	98.20	440
50	819	657	160	1159	98.3	98.4	98.1	97.7	2.0	3.3	3.8	3.8	2.0	45	98.30	440
75	820	803	175	2259	98.5	98.3	97.7	97.1	2.8	4.8	6.5	5.8	2.8	50	98.50	711
100	821	960	250	2504	98.6	98.4	98.0	97.5	2.3	4.3	5.5	5.0	2.3	50	98.60	926
167	814	1665	570	3094	98.7	98.8	98.6	98.3	1.5	6.3	9.0	8.8	1.5	50	98.70	955
<b>Type DS-3 115 °C Rise NEMA TP-1 Efficient Single-Phase</b>																
15	816	264	80	437	97.8	98.1	97.8	97.3	2.4	2.2	3.3	2.2	2.4	45	97.70	239
25	818	420	110	603	97.9	98.0	98.0	97.7	2.0	2.9	3.2	2.6	2.0	45	98.00	287
37.5	818	450	125	1217	98.2	98.2	97.5	96.9	2.9	4.5	5.9	5.1	2.9	45	98.20	433
50	819	703	300	1409	98.4	98.4	98.0	97.6	2.2	3.8	4.7	4.1	2.2	—	98.30	499
75	820	793	175	2178	98.5	98.3	97.8	97.2	2.7	4.7	6.2	5.6	2.7	50	98.50	702
<b>Type DS-3 80 °C Rise NEMA TP-1 Efficient Single-Phase</b>																
15	818	407	115	293	97.3	98.2	98.3	98.2	1.2	1.7	1.8	1.4	1.2	45	97.70	125
25	818	430	300	679	97.9	98.4	98.3	98.1	1.5	2.6	3.0	2.6	1.5	45	98.00	164
37.5	819	685	300	729	98.1	98.6	98.6	98.5	1.1	2.2	2.6	2.3	1.1	45	98.20	205
50	820	799	180	1013	98.3	98.6	98.4	98.1	1.7	2.9	3.4	2.9	1.7	45	98.30	329
75	821	1042	250	1447	98.3	98.6	98.4	98.1	1.6	3.4	3.8	3.5	1.6	50	98.50	338
<b>Type DT-3 150 °C Rise NEMA TP-1 Efficient</b>																
15	912D	250	150	755	98.9	97.0	96.4	95.7	4.2	5.3	4.8	2.6	4.0	45	97.00	107
30	912D	350	165	1100	97.3	97.5	97.0	96.5	3.2	4.5	5.2	4.1	3.1	45	97.50	204
37.5	912D	415	210	1382	97.5	97.6	97.1	96.5	3.2	4.8	4.0	2.5	3.1	45	97.70	213
45	912D	416	215	1786	97.4	97.4	96.9	96.2	3.6	5.5	4.6	3.0	3.5	45	97.70	212
50	914D	647	270	1220	97.7	98.2	98.0	97.7	2.0	3.5	2.8	2.0	1.9	45	98.00	357
75	914D	643	320	2903	97.9	97.5	97.1	96.4	3.6	7.4	4.3	2.5	3.4	50	98.00	338
112.5	916A	876	420	3699	97.9	97.9	97.4	96.8	3.0	6.7	5.1	4.2	2.9	50	98.20	395
150	916A	1064	530	4269	98.1	98.2	97.8	97.3	2.7	5.3	4.3	3.5	2.5	50	98.30	584
225	917	1569	560	7124	98.4	98.1	97.5	97.0	3.2	8.7	7.4	6.8	2.9	55	98.50	832
300	923	2050	730	7959	98.4	98.3	97.9	97.4	2.6	6.7	5.5	4.9	2.4	55	98.60	964
500	919	3681	1400	8292	98.8	98.9	98.7	98.4	1.6	7.4	6.8	6.7	1.4	60	98.70	1279
<b>Type DT-3 115 °C Rise NEMA TP-1 Efficient</b>																
15	912D	256	95	669	97.7	97.8	97.3	96.7	4.0	5.4	4.8	2.9	3.8	45	97.00	76
30	912D	337	180	1077	97.7	97.8	97.3	96.8	3.0	6.2	4.6	3.5	3.0	45	97.50	144
45	912D	446	215	1625	97.7	97.7	97.2	96.6	3.2	5.2	4.4	3.1	3.1	45	97.70	219
50	914D	630	270	1213	97.8	98.2	98.0	97.7	2.0	3.5	3.0	2.3	1.9	45	98.00	320
75	914D	662	320	2346	97.9	98.0	97.6	97.0	2.8	5.4	4.7	3.9	2.7	50	98.00	280
112.5	916A	914	400	2953	98.1	98.2	97.9	97.4	2.5	5.7	5.0	4.5	2.3	50	98.20	345
150	916A	1132	530	3364	98.3	98.5	98.2	97.8	2.0	4.8	4.4	4.0	1.9	50	98.30	535
225	917	2036	650	6445	98.4	98.3	97.8	97.3	2.9	8.8	8.1	7.7	2.6	55	98.50	524
300	923	2325	830	6038	98.6	98.7	98.4	98.1	2.0	5.7	5.2	4.9	1.7	55	98.60	620
500	919	3681	1400	7841	98.8	98.9	98.7	98.5	1.4	6.8	6.8	6.6	1.3	60	98.70	1344
<b>Type DT-3 80 °C Rise NEMA TP-1 Efficient</b>																
15	912D	349	135	390	96.6	97.7	97.7	97.6	1.8	2.4	2.1	1.3	1.7	45	97.00	150
30	912D	410	210	823	97.3	97.9	97.7	97.4	2.1	3.4	3.0	2.1	2.0	45	97.50	164
45	912D	504	200	1308	97.9	98.0	97.7	97.2	2.5	4.5	3.9	3.1	2.5	45	97.70	158
75	916A	818	370	1837	97.9	98.2	98.0	97.7	2.0	9.3	4.3	3.8	2.0	50	98.00	312
112.5	916A	1065	440	2409	98.1	98.3	98.0	97.6	1.8	3.8	3.3	2.8	1.8	50	98.20	584
150	917	1410	650	3349	98.3	98.5	98.3	97.9	1.9	3.9	3.7	3.2	1.8	50	98.30	531
225	923	2030	830	4096	98.4	98.7	98.5	98.3	1.6	5.4	5.4	5.2	1.5	55	98.50	856
300	919	3041	1100	4646	98.5	98.8	98.7	98.5	1.4	5.6	6.1	6.0	1.2	55	98.60	1251

① Typical values for copper windings. Refer to **Page 19.1-25** for typical data for aluminum windings. Up-to-date design data is available at [www.eaton.com](http://www.eaton.com).

② Actual impedance may vary ±7.5%.

**Note:** Performance data is based upon 480 V delta primary and a 208Y/120 V secondary for three-phase transformers; 240 x 480 V primary and a 120/240 V secondary for single-phase transformers. Refer to Eaton for 5 kV class information. All data is subject to future revision.

## Technical Data

**Table 19.1-22. Typical Data for 480 V Class K-Rated, TP-1 Dry-Type Transformers, Copper Wound ①**

kVA	Frame	Weight	Losses in Watts		Efficiency (T Rise +20 °C)				% Regulation		% Imp. T Rise +20 °C ②	X T Rise +20 °C	R T Rise +20 °C	Sound Level dB	TP1 Efficiency	Inrush Practical Max.	
			No Load	Total at Rise +20 °C	25%	50%	75%	Full Load	100% PF	80% PF							
<b>Type KT-4 150 °C Rise NEMA TP-1 Efficient</b>																	
15	912D	251	100	635	96.8	97.1	96.6	96.0	3.7	5.0	4.2	2.1	3.6	45	97.00	88	
30	912D	326	165	1134	97.4	97.5	97.1	96.5	3.5	5.3	4.3	2.9	3.2	45	97.50	168	
45	912D	479	220	1505	97.6	97.8	97.3	96.8	3.0	5.6	5.0	4.1	2.9	45	97.70	223	
75	914D	463	300	2883	97.9	97.7	97.1	96.4	3.6	7.1	5.9	4.7	3.4	50	98.00	325	
112.5	916A	977	440	2952	98.1	98.2	97.9	97.5	2.6	6.6	5.6	5.1	2.2	50	98.20	344	
150	916A	1212	540	3716	98.3	98.4	98.0	97.6	2.4	6.0	5.1	4.6	2.1	50	98.30	524	
225	917	1815	650	5420	98.4	98.5	98.1	97.7	2.4	7.6	6.5	6.2	2.1	55	98.50	565	
300	923	2400	830	6259	98.6	98.6	98.4	98.0	2.2	6.3	5.2	4.9	1.8	55	98.60	864	
<b>Type KT-4 115 °C Rise NEMA TP-1 Efficient</b>																	
15	912D	256	95	702	96.7	96.9	96.3	95.6	4.2	5.7	5.0	2.9	4.0	45	97.00	93	
30	912D	341	165	1007	97.4	97.6	97.3	96.8	3.0	4.8	4.2	3.1	2.8	45	97.50	155	
45	912D	526	220	1200	97.9	98.1	97.9	97.5	2.3	5.0	4.1	3.5	2.2	50	97.70	211	
75	914D	759	300	1715	98.1	98.3	98.1	97.8	1.9	5.0	4.5	4.1	1.9	50	98.00	309	
112.5	916A	1030	470	2735	98.0	98.3	98.0	97.7	2.2	4.4	3.8	3.2	2.0	50	98.20	390	
150	917	1631	650	3076	98.2	98.5	98.3	98.1	1.7	4.9	4.5	4.2	1.6	50	98.30	416	
225	918A	1965	690	4434	98.5	98.6	98.4	98.1	1.9	5.6	5.3	5.0	1.7	55	98.50	659	
300	923	2337	830	6127	98.6	98.7	98.4	98.0	2.0	5.2	4.7	4.3	1.8	55	98.60	729	
<b>Type KT-4 80 °C Rise NEMA TP-1 Efficient</b>																	
15	912D	365	165	371	97.0	98.0	98.1	98.0	1.5	2.3	2.1	1.5	1.4	45	97.00	166	
30	912D	424	210	787	97.3	97.9	97.8	97.6	2.0	3.2	2.9	2.2	1.9	45	97.50	219	
45	914D	653	290	977	97.4	98.1	98.1	98.0	1.6	3.1	3.0	2.5	1.5	45	97.70	308	
75	916A	640	350	1951	97.8	98.1	97.8	97.5	2.2	5.2	4.9	4.4	2.1	50	98.00	284	
112.5	916A	1264	560	2009	98.2	98.7	98.6	98.4	1.4	4.3	4.2	4.0	1.3	50	98.20	483	
150	917	1825	650	2873	98.5	98.7	98.5	98.2	1.6	6.1	6.4	6.3	1.5	50	98.30	429	
225	923	2096	890	4449	98.3	98.6	98.4	98.1	1.8	6.5	6.6	6.4	1.6	55	98.50	764	
<b>Type KT-13 150 °C Rise NEMA TP-1 Efficient</b>																	
15	912D	346	165	461	96.2	97.4	97.5	97.3	2.1	3.0	2.5	1.6	2.0	45	97.00	176	
30	912D	390	190	908	97.2	97.7	97.5	97.1	2.6	4.0	3.3	2.3	2.4	45	97.50	193	
45	914D	623	235	1328	97.6	97.9	97.6	97.2	2.5	3.2	2.8	1.4	2.4	45	97.70	285	
75	916A	848	370	2402	97.7	97.9	97.5	97.0	2.8	5.7	4.5	3.6	2.7	50	98.00	348	
112.5	916A	1080	455	2991	98.0	98.2	97.9	97.4	2.4	4.3	3.5	2.7	2.3	50	98.20	393	
150	917	1431	600	3686	98.2	98.3	98.1	97.7	2.3	5.1	4.2	3.7	2.1	50	98.30	416	
225	923	2129	830	4250	98.4	98.6	98.4	98.2	2.0	6.3	5.4	5.1	1.5	55	98.50	923	
<b>Type KT-13 115 °C Rise NEMA TP-1 Efficient</b>																	
15	912D	341	165	378	96.6	97.8	97.9	97.9	1.5	2.4	2.1	1.6	1.4	45	97.00	157	
30	912D	444	188	824	97.1	97.8	97.6	97.3	2.2	3.6	3.1	2.2	2.1	45	97.50	206	
45	914D	598	250	1476	97.4	97.7	97.4	96.9	2.8	4.6	4.0	2.9	2.7	45	97.70	313	
75	916A	894	350	2128	97.9	98.1	97.9	97.5	1.9	5.1	4.6	4.0	2.4	50	98.00	282	
112.5	916A	1054	460	2612	98.1	98.3	98.1	97.8	2.0	4.3	3.3	2.6	1.9	50	98.20	458	
150	917	1399	600	3185	98.2	98.5	98.3	98.0	2.0	5.9	5.4	5.1	1.7	50	98.30	460	
225	923	2088	890	4382	98.3	98.6	98.4	98.2	1.8	6.1	5.7	5.5	1.6	55	98.50	830	
<b>Type KT-13 80 °C Rise NEMA TP-1 Efficient</b>																	
15	912D	370	165	382	96.7	97.8	97.9	97.8	1.5	2.4	2.2	1.6	1.4	45	97.00	157	
30	912D	490	188	595	97.4	98.2	98.2	98.1	1.4	3.0	2.8	2.5	1.4	45	97.50	197	
45	914D	635	290	1189	97.4	97.9	97.8	97.5	2.1	3.9	3.5	2.8	2.0	45	97.70	245	
75	916A	987	410	1351	97.7	98.9	98.4	98.3	1.4	2.8	2.6	2.3	1.3	50	98.00	530	
112.5	916A	854	560	2039	98.1	98.6	98.5	98.3	1.4	4.2	4.3	4.1	1.3	50	98.20	458	
150	918A	1807	650	3053	98.0	98.4	98.3	98.0	1.7	4.3	4.0	3.7	1.6	50	98.30	490	
225	919	4091	1200	2364	98.2	98.9	99.1	99.1	0.6	2.7	2.9	2.8	0.5	55	98.50	1440	

 ① Typical values for copper windings. Refer to **Page 19.1-26** for typical data for aluminum windings. Up-to-date design data is available at [www.eaton.com](http://www.eaton.com).

② Actual impedance may vary ±7.5%.

**Note:** Performance data is based upon 480 V delta primary and a 208Y/120 V secondary for three-phase transformers; 240 x 480 V primary and a 120/240 V secondary for single-phase transformers. Refer to Eaton for 5 kV class information. All data is subject to future revision.

**Technical Data**

**Table 19.1-23. Typical Data for 480 V Class K-Rated and HMT, TP-1 and CSL-3 Dry-Type Transformers, Copper Wound**

kVA	Frame	Weight	Losses in Watts		Efficiency (T Rise +20 °C)				% Regulation		% Imp. T Rise +20 °C ①	X T Rise +20 °C	R T Rise +20 °C	Sound Level dB	TP1 Efficiency	Inrush Practical Max.
			No Load	Total at Rise +20 °C	25%	50%	75%	Full Load	100% PF	80% PF						
<b>Type KT-13 115 °C Rise CSL-3 Efficient</b>																
15	912D	325	78	359	97.6	98.1	98.0	97.7	2.0	3.7	3.2	2.6	1.9	45	98.00	102
30	912D	370	125	636	98.1	98.4	98.3	98.0	1.7	2.7	2.3	1.6	1.7	45	98.30	260
45	915D	635	135	1076	98.5	98.5	98.1	97.7	2.2	4.1	3.5	2.8	2.1	45	98.50	206
75	915D	870	225	1529	98.5	98.6	98.4	98.0	1.9	4.9	4.4	4.1	1.7	50	98.60	331
112.5	917	1526	350	1768	98.6	98.8	98.7	98.5	1.3	3.5	3.1	2.8	1.3	50	98.80	816
150	917	1665	350	2419	97.8	98.9	98.7	98.4	1.5	4.5	4.2	3.9	1.4	50	98.90	659
225	918A	2094	650	3650	98.9	98.9	98.8	98.5	1.5	5.4	5.2	5.1	1.3	55	99.00	895
300	919	3900	750	3731	98.9	99.1	99.0	98.8	1.3	5.2	5.2	5.1	1.0	55	99.04	997
<b>Type KT-9 115 °C Rise CSL-3 Efficient</b>																
15	912D	335	78	353	97.4	98.0	98.0	97.7	2.0	3.7	3.2	2.6	1.8	45	98.00	96
30	912D	406	125	670	98.0	98.3	98.1	97.8	1.9	2.7	2.4	1.5	1.8	45	98.30	260
45	915D	635	135	1075	98.6	98.5	98.2	97.7	2.3	4.1	3.5	2.8	2.1	45	98.50	201
75	915D	870	210	1551	98.5	98.6	98.3	98.0	1.9	4.0	3.6	3.1	1.8	50	98.60	319
112.5	917	1526	350	1583	98.6	98.9	98.8	98.6	1.2	3.0	2.7	2.5	1.1	50	98.80	827
150	917	1665	350	2463	98.8	98.9	98.7	98.4	1.6	4.5	4.2	4.0	1.4	50	98.90	643
225	918A	2094	650	3766	98.8	98.9	98.7	98.4	1.7	5.5	5.2	5.0	1.4	55	99.00	926
<b>Type NON HMT 115 °C Rise NEMA TP-1 Efficient</b>																
15	912D	362	80	527	97.6	97.7	97.3	96.7	3.2	5.9	5.1	4.2	3.0	45	97.00	—
30	912D	430	100	1040	98.3	98.0	97.4	96.7	3.2	6.2	5.4	4.4	3.1	45	97.50	—
45	915D	627	170	1368	98.3	98.2	97.7	97.2	2.8	6.0	5.2	4.4	2.7	45	97.70	—
75	916A	926	250	2096	98.4	98.3	97.9	97.4	2.6	7.0	6.2	5.7	2.5	50	98.00	—
112.5	917	1628	400	2515	98.4	98.5	98.3	97.9	2.0	5.5	4.9	4.5	1.9	50	98.20	—
150	918A	2001	500	2688	98.5	98.7	98.6	98.3	1.6	5.6	5.2	5.0	1.5	50	98.30	—
225	919X	3596	590	3310	98.8	98.9	98.8	98.6	1.5	6.2	6.0	5.9	1.2	55	98.50	—
300	919X	3891	800	4854	98.7	98.9	98.7	98.4	1.7	7.1	7.0	6.8	1.4	55	98.60	—
<b>Type THR HMT 115 °C Rise NEMA TP-1 Efficient</b>																
15	912D	—	80	708	97.1	97.0	96.4	95.5	4.3	7.4	6.3	4.7	4.2	45	97.00	—
30	912D	450	100	1409	98.0	97.4	96.5	95.6	4.7	8.0	6.8	5.2	4.4	45	97.50	—
45	915D	610	170	1374	98.2	98.1	97.7	97.1	2.8	4.8	4.2	3.2	2.7	45	97.70	—
75	916A	868	250	2341	98.2	98.1	97.6	97.0	2.9	6.6	5.8	5.0	2.8	50	98.00	—
112.5	917	1643	400	2685	98.3	98.4	98.1	97.7	2.2	5.5	5.0	4.6	2.0	50	98.20	—
150	918A	—	500	3304	98.5	98.6	98.3	97.9	2.0	6.7	6.3	6.0	1.9	50	98.30	—
225	919X	3370	590	3712	98.7	98.8	98.7	98.4	1.7	6.6	6.4	6.2	1.4	55	98.50	—
300	919X	3894	800	4688	98.9	99.0	98.8	98.5	1.7	7.4	7.2	7.1	1.3	55	98.60	—

① Actual impedance may vary ±7.5%.

**Note:** Performance data is based upon 480 V delta primary and a 208Y/120 V secondary for three-phase transformers; 240 x 480 V primary and a 120/240 V secondary for single-phase transformers. Refer to Eaton for 5 kV class information. All data is subject to future revision.

## Dimensions

### Dimensions—Ventilated Transformers

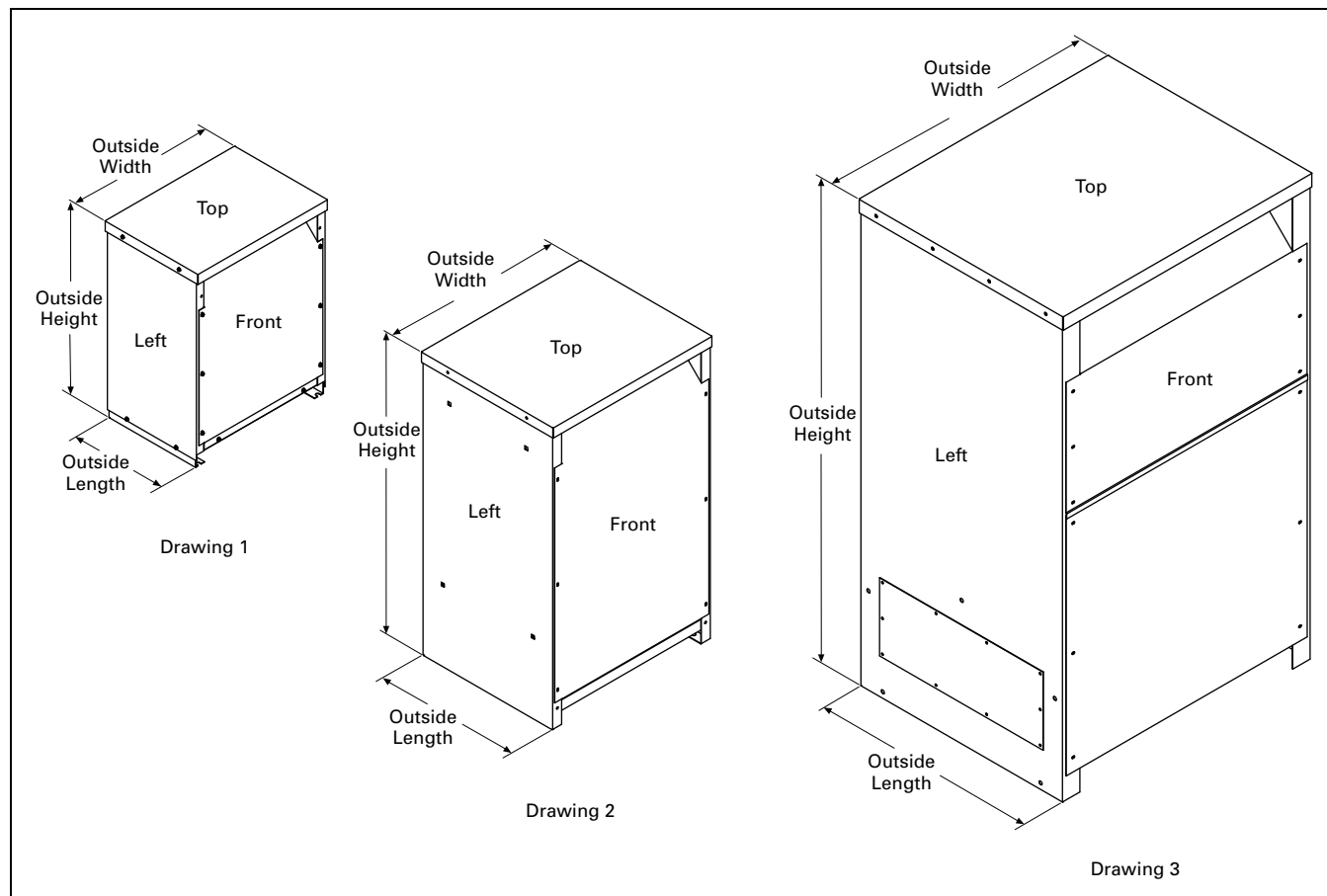
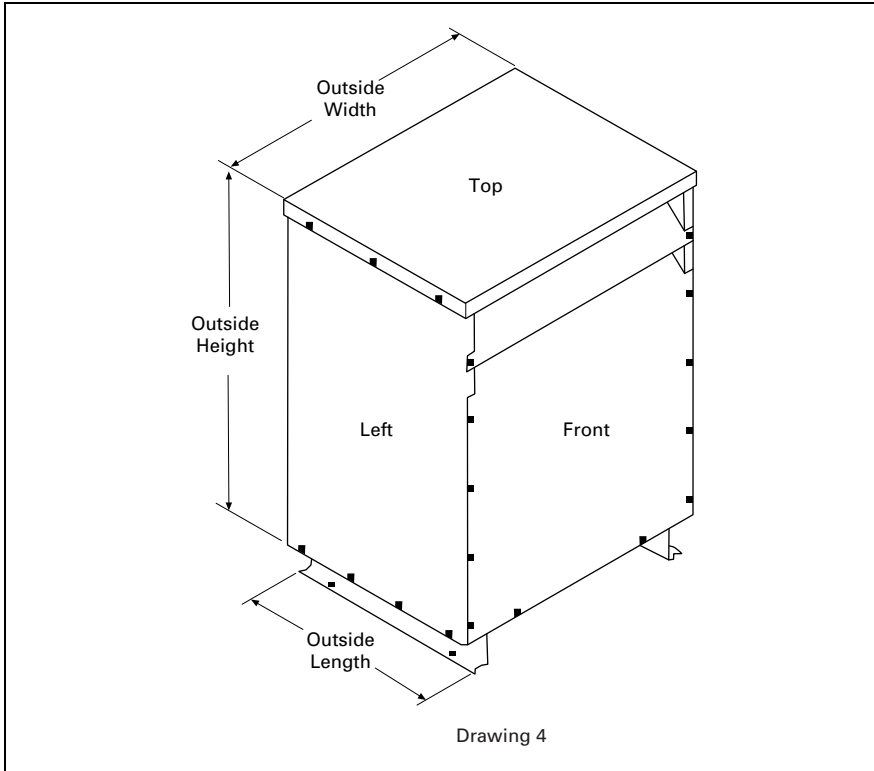

Figure 19.1-5. Enclosure Dimensional Drawings—Ventilated Transformers

Table 19.1-24. Ventilated Transformers—Approximate Dimensions in Inches (mm)

Frame	Drawing Number	Dimensions		
		Height	Width	Length
FR816	1	31.30 (795.0)	22.89 (581.4)	18.39 (467.2)
FR818	1	37.59 (954.8)	22.89 (581.4)	20.36 (517.10)
FR819	2	42.03 (1067.6)	24.22 (615.2)	23.84 (605.5)
FR820	2	42.03 (1067.6)	24.22 (615.2)	23.84 (605.5)
FR814, FR814E	2	62.91 (1597.9)	29.97 (761.2)	33.97 (862.8)
FR821	2	62.91 (1597.9)	29.97 (761.2)	33.97 (862.8)
FR912B, FR912D	1	30.00 (762.0)	23.00 (584.2)	16.50 (419.1)
FR914D	1	39.00 (990.6)	29.00 (736.6)	22.00 (558.8)
FR915D	1	39.00 (990.6)	29.00 (736.6)	22.00 (558.8)
FR916A	2	48.56 (1233.4)	28.22 (716.8)	23.42 (594.9)
FR917	2	56.17 (1426.7)	31.44 (798.6)	24.67 (626.6)
FR918A	2	62.18 (1579.4)	31.44 (798.6)	30.68 (779.3)
FR923	2	57.54 (1461.5)	36.69 (931.9)	32.65 (829.3)
FR919, FR919E, FR919X	3	75.00 (1905.0)	44.20 (1122.7)	36.23 (920.2)
FR920, FR920E, FR920X	3	75.00 (1905.0)	44.20 (1122.7)	36.23 (920.2)
FR922	3	90.00 (2286.0)	69.26 (1759.2)	42.65 (1083.3)

**Dimensions**

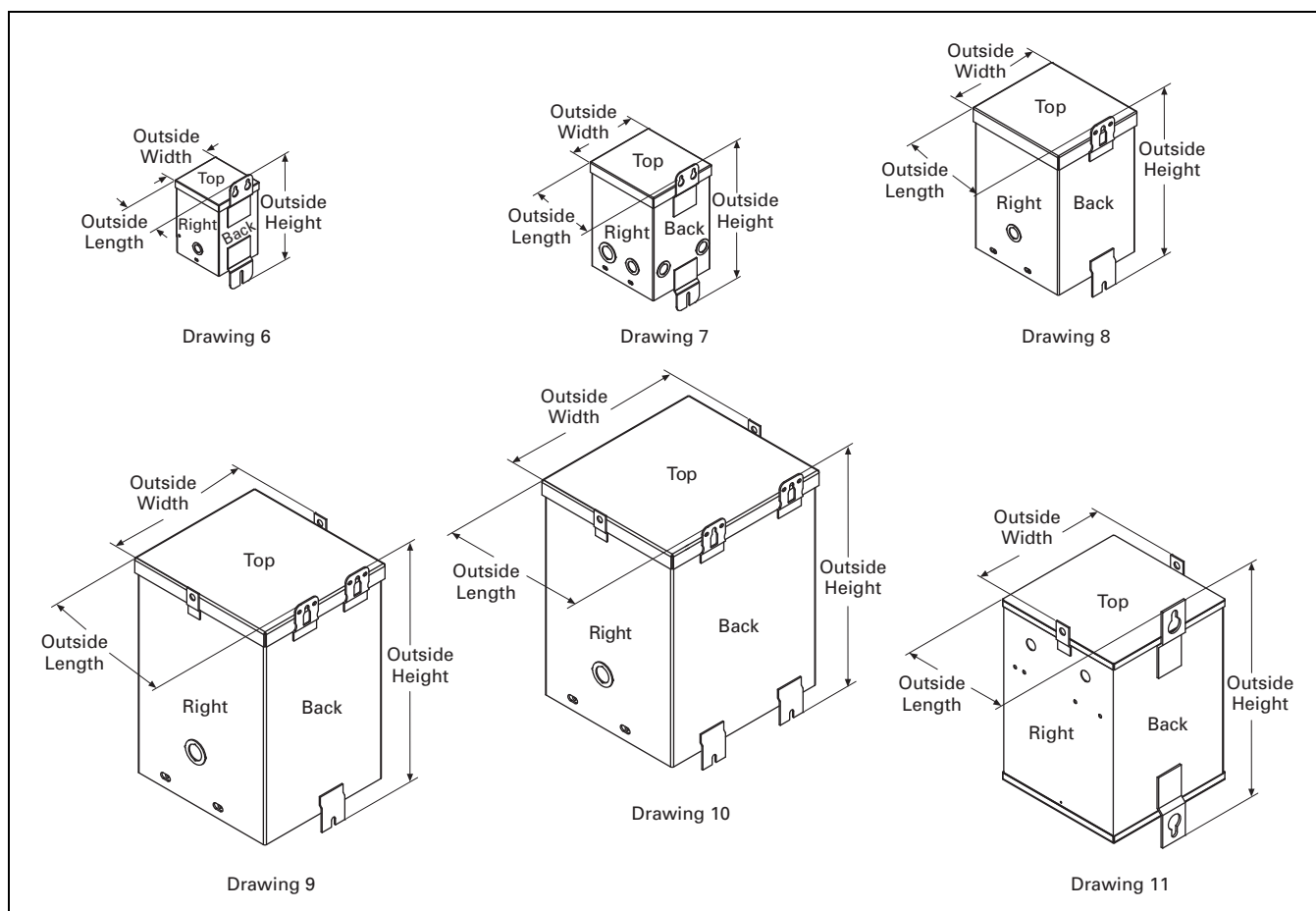

**Figure 19.1-6. Enclosure Dimensional Drawings—Ventilated Transformers**

**Table 19.1-25. Ventilated Transformers—Approximate Dimensions in Inches (mm)**

Frame	Drawing Number	Dimensions		
		Height	Width	Length
939	4	28.00 (711.2)	21.86 (555.2)	17.75 (450.8)
940	4	36.77 (934.0)	24.86 (631.4)	21.13 (536.7)
942	4	43.00 (1092.2)	30.50 (774.7)	24.00 (609.6)
943	4	50.92 (1293.4)	34.49 (876.0)	31.48 (800.0)
944	4	60.00 (1524.0)	38.00 (965.2)	33.45 (849.6)
945	4	60.00 (1524.0)	45.00 (1143.0)	36.00 (914.4)

## Dimensions—Encapsulated

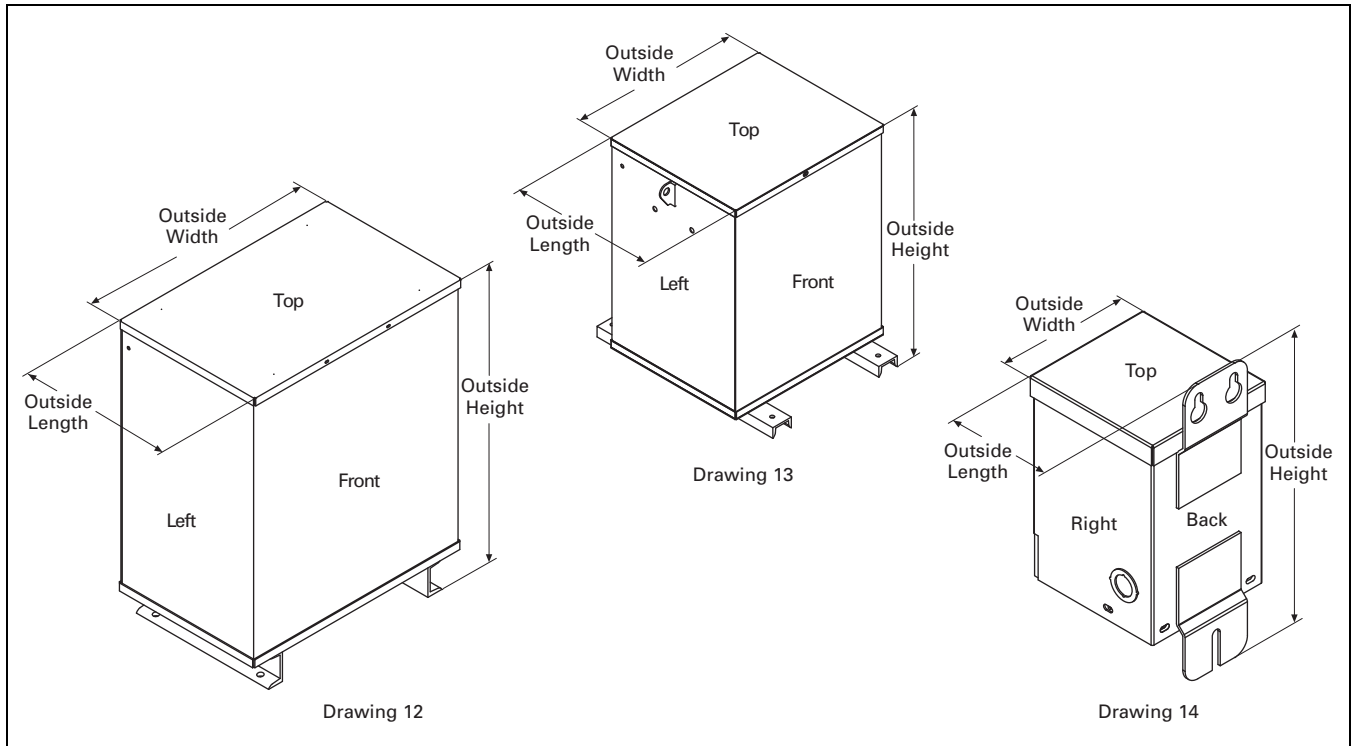

**Figure 19.1-7. Enclosure Dimensional Drawings—Encapsulated Transformers**

**Table 19.1-26. Encapsulated Transformers—Approximate Dimensions in Inches (mm)**

Frame	Drawing Number	Dimensions		
		Height	Width	Length
FR52	6	8.91 (226.3)	4.11 (104.4)	4.00 (101.6)
FR54	6	8.91 (226.3)	4.11 (104.4)	4.00 (101.6)
FR55	6	8.91 (226.3)	4.11 (104.4)	4.00 (101.6)
FR56	7	8.97 (227.8)	4.87 (123.7)	4.06 (103.1)
FR57	7	8.97 (227.8)	4.87 (123.7)	4.91 (124.7)
FR58A	7	11.28 (286.5)	5.99 (152.1)	5.75 (146.1)
FR59A	7	11.28 (286.5)	5.99 (152.1)	5.75 (146.1)
FR67	7	13.41 (340.6)	6.37 (161.8)	6.52 (165.6)
FR68	7	13.41 (340.6)	6.37 (161.8)	6.52 (165.6)
FR176	8	14.25 (361.9)	7.69 (195.3)	8.00 (203.2)
FR177	9	16.00 (406.4)	10.38 (263.7)	9.89 (251.2)
FR301	11	22.26 (565.4)	12.71 (322.8)	12.79 (324.9)
FR178	9	16.00 (406.4)	10.38 (263.7)	9.89 (251.2)
FR302	11	25.26 (641.6)	12.71 (322.8)	12.79 (324.9)
FR304	11	25.26 (641.6)	14.72 (373.9)	14.82 (376.4)
FR179	9	19.00 (482.6)	13.38 (339.9)	10.52 (267.2)
FR180	9	19.00 (482.6)	13.38 (339.9)	10.52 (267.2)
FR182	10	23.31 (592.1)	16.35 (415.3)	14.12 (358.6)
FR190	10	26.31 (668.3)	16.35 (415.3)	14.12 (358.6)

**Dimensions—Encapsulated**



**Figure 19.1-8. Enclosure Dimensional Drawings—Encapsulated Transformers**

**Table 19.1-27. Encapsulated Transformers—Approximate Dimensions in Inches (mm)**

Frame	Drawing Number	Dimensions		
		Height	Width	Length
FR132	13	20.67 (525.0)	19.02 (483.1)	13.59 (345.2)
FR300A	12	28.24 (717.3)	22.42 (569.5)	14.06 (357.1)
FR57P	14	9.34 (237.2)	4.45 (113.0)	5.18 (131.6)
FR58AP	14	11.68 (296.7)	4.99 (126.7)	5.99 (152.1)
FR567P	14	13.03 (330.9)	5.74 (145.8)	6.56 (166.6)
FR568P	14	13.78 (350.0)	6.22 (158.0)	6.32 (160.5)

## Dimensions—Encapsulated

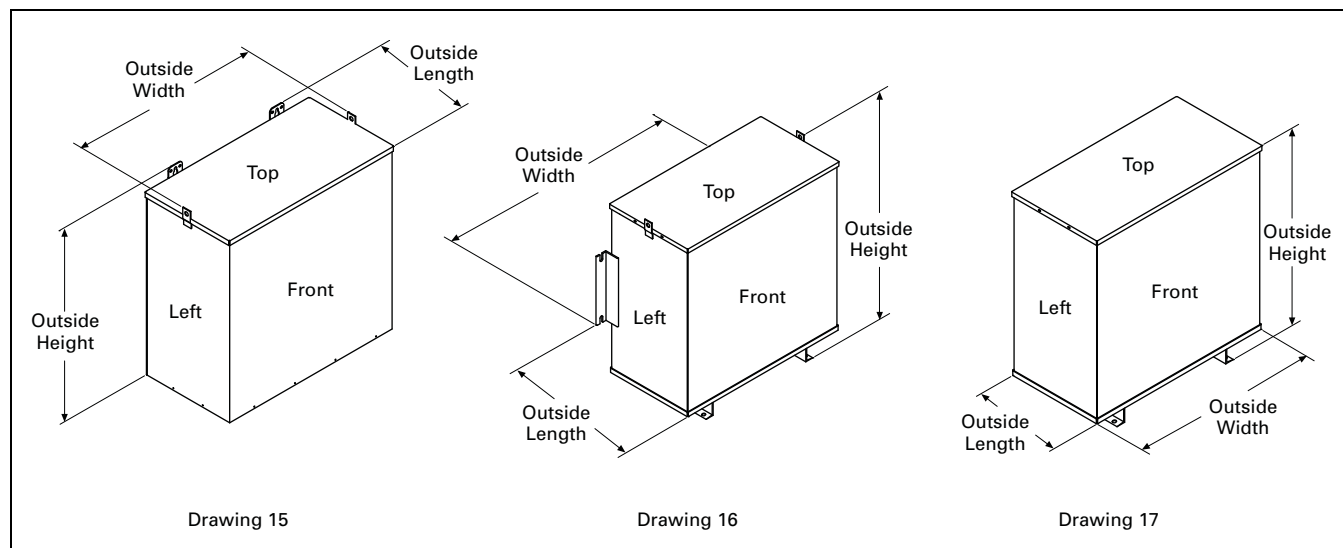

Figure 19.1-9. Enclosure Dimensional Drawings—Encapsulated Transformers

Table 19.1-28. Encapsulated Transformers—Approximate Dimensions in Inches (mm)

Frame	Drawing Number	Dimensions		
		Height	Width	Length
FR201	15	13.40 (340.4)	15.93 (404.6)	8.26 (209.8)
FR102	15	13.12 (333.2)	19.59 (497.6)	7.09 (180.1)
FR103	15	15.90 (403.9)	16.93 (430.0)	10.01 (254.3)
FR200	15	15.90 (403.9)	16.93 (430.0)	10.01 (254.3)
FR97	15	15.19 (385.8)	25.68 (652.3)	8.38 (212.9)
FR95	15	17.38 (441.5)	20.00 (508.0)	10.52 (267.2)
FR243	16	17.38 (441.5)	20.00 (508.0)	10.52 (267.2)
FR96	15	16.19 (411.2)	29.68 (753.9)	9.42 (239.3)
FR244	16	28.15 (715.0)	26.58 (675.1)	14.66 (372.4)
FR245	17	32.06 (814.3)	30.29 (769.4)	15.68 (398.3)



**Dimensions**

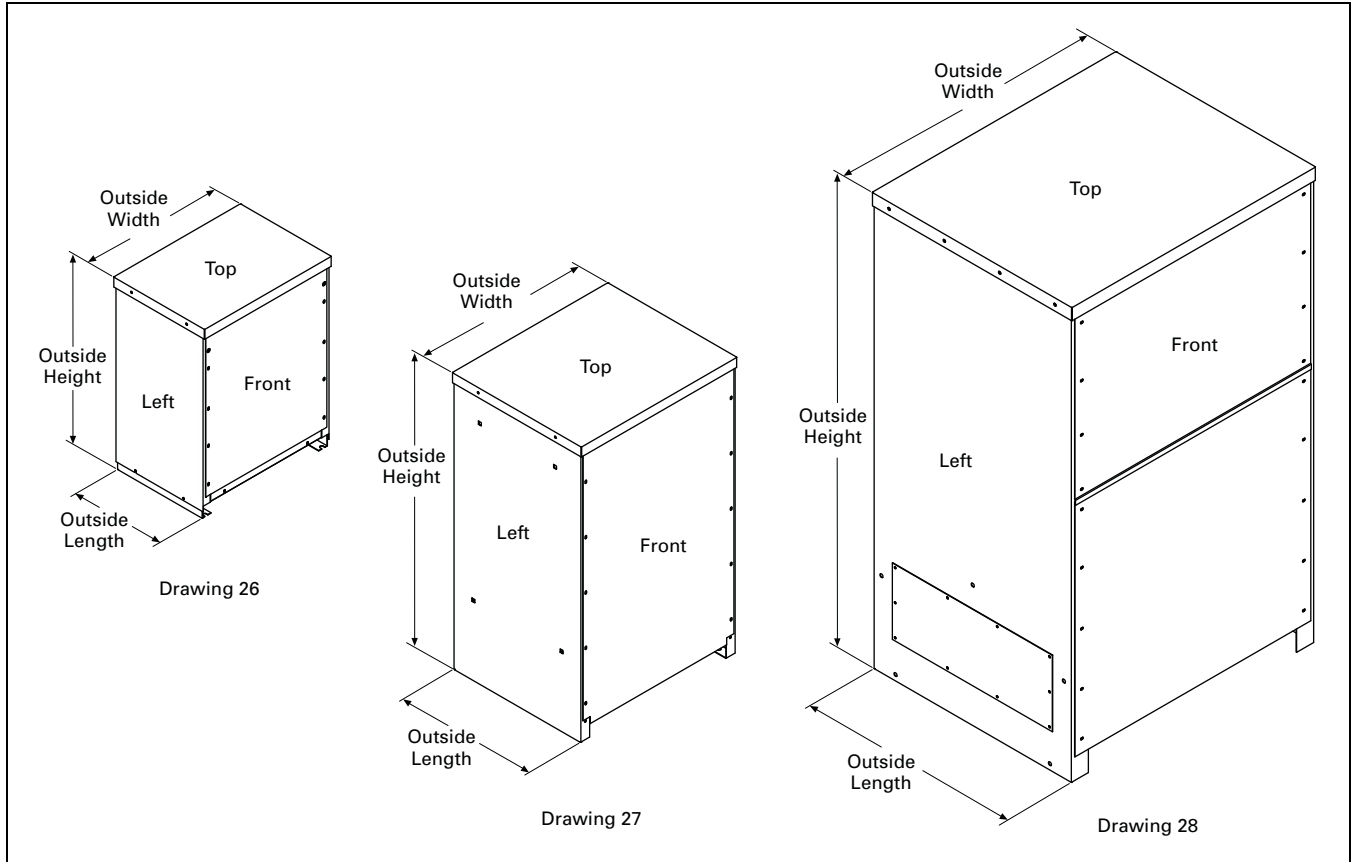

**Figure 19.1-10. Enclosure Dimensional Drawings—Totally Enclosed Nonventilated Transformers**

**Table 19.1-29. Totally Enclosed Nonventilated Transformers—Approximate Dimensions in Inches (mm)**

Frame	Drawing Number	Dimensions		
		Height	Width	Length
FR818N	26	37.59 (954.8)	22.89 (581.4)	20.36 (517.1)
FR819N	27	42.03 (1067.6)	24.22 (615.2)	23.84 (605.5)
FR820N	27	42.03 (1067.6)	24.22 (615.2)	23.84 (605.5)
FR814N	27	62.91 (1597.9)	29.97 (761.2)	33.97 (862.8)
FR912BN, FR912DN	26	30.00 (762.0)	23.00 (584.2)	16.50 (419.1)
FR914DN	26	39.18 (995.2)	29.00 (736.6)	22.00 (558.8)
FR915DN	26	39.18 (995.2)	29.00 (736.6)	22.00 (558.8)
FR916AN	27	46.58 (1183.1)	28.22 (716.8)	23.42 (594.9)
FR917N	27	56.18 (1427.0)	31.44 (798.6)	24.67 (626.8)
FR918AN	27	62.18 (1579.4)	31.44 (798.6)	30.68 (779.3)
FR923N	27	57.50 (1460.5)	36.69 (931.9)	32.65 (829.3)
FR919N	28	75.00 (1905.0)	44.21 (1122.9)	36.23 (920.2)
FR920N	28	75.00 (1905.0)	44.21 (1122.9)	36.23 (920.2)

See Eaton Catalog CA08100003E, Electrical Sector Solutions Volume 2— Commercial Distribution, Tab 2 for product information and frame cross-reference data.

## Frequently Asked Questions About Transformers

### Can 60 Hz transformers be used at other frequencies?

Transformers rated for 60 Hz can be applied to circuits with a higher frequency, as long as the nameplate voltages are not exceeded. The higher the frequency that you apply to a 60 Hz transformer, the less voltage regulation you will have. 60 Hz transformers may be used at lower frequencies, but only at reduced voltages corresponding to the reduction in frequency. For example, a 480–120 V 60 Hz transformer can carry rated kVA at 50 Hz but only when applied as a 400–100 V transformer ( $50/60 \times 480 = 400$ ).

### Can single-phase transformers be used on a three-phase source?

Yes. Any single-phase transformer can be used on a three-phase source by connecting the primary terminals of the single-phase transformer to any two wires of a three-phase system. It does not matter whether the three-phase source is three-phase three-wire or three-phase four-wire. The output of the transformer will be single-phase.

### Can transformers be used to create three-phase power from a single-phase system?

No. Single-phase transformers alone cannot be used to create the phase-shifts required for a three-phase system. Phase-shifting devices (reactors or capacitors) or phase converters in conjunction with transformers are required to change single-phase power to three-phase.

### What considerations need to be taken into account when operating transformers at high altitudes?

At altitudes greater than 3300 ft (1000 m), the density of the air is lesser than at lower elevations. This reduces the ability of the air surrounding a transformer to cool it, so the temperature rise of the transformer is increased. Therefore, when a transformer is being installed at altitudes greater than 3300 ft (1000 m) above sea level, it is necessary to derate the nameplate kVA by 0.3% for each 330 ft (100 m) in excess of 3300 feet.

### What considerations need to be taken into account when operating transformers where the ambient temperature is high?

Eaton's dry-type transformers are designed in accordance with ANSI standards to operate in areas where the average maximum ambient temperature is 40 °C. For operation in ambient temperatures above 40 °C, there are two options:

1. Order a custom-designed transformer made for the specific application.
2. Derate the nameplate kVA of a standard transformer by 8% for each 10 °C of ambient above 40 °C.

### What is the normal life expectancy of a transformer?

When a transformer is operated under ANSI/IEEE basic loading conditions (ANSI C57.96), the normal life expectancy of a transformer is 20 years. The ANSI/IEEE basic loading conditions are:

- A. The transformer is continuously loaded at rated kVA and rated voltages.
- B. The average temperature of the ambient air during any 24-hour period is equal to 30 °C and at no time exceeds 40 °C.
- C. The altitude where the transformer is installed does not exceed 3300 ft (1000 m).

### What are Insulation Classes?

Insulation classes were originally used to distinguish insulating materials operating at different temperatures. In the past, letters were used for the different designations. Recently, insulation system temperatures (°C) have replaced the letters' designations.

Table 19.1-30. Insulation Classes

Previous Designation	Insulation System Rating (°C)
Class A	105
Class B	150
Class F	180
Class H	220
Class R	220

### How do you know if the enclosure temperature is too hot?

UL and CSA standards strictly regulate the highest temperature that an enclosure can reach. For ventilated transformers, the temperature of the enclosure should not increase by more than 50 °C in °C ambient at full rated current. For encapsulated transformers, the temperature of the enclosure should not increase by more than 65 °C in a 25 °C ambient at full rated current. This means that it is permissible for the temperature of the enclosure to reach 90 °C (194 °F). Although this temperature is very warm to the touch, it is within the allowed standards. A thermometer should be used to measure enclosure temperatures, not your hand.

### Can transformers be reverse-connected (reverse-fed)?

Yes, with limitations. Eaton's single-phase transformers rated 3 kVA and larger can be reverse-connected without any loss of kVA capacity or any adverse effects. Transformers rated 2 kVA and below, because there is a turns ratio compensation on the low voltage winding that adjusts voltage between no load and full load conditions, should not be reverse-fed.

Three-phase transformers with either delta-delta or delta-wye configurations can also be reverse-connected for step-up operation. When reverse-feeding a delta-wye connected transformer, there are two important considerations to take into account: (1) The neutral is not connected, only the three-phase wires of the wye system are connected; and (2) the ground strap between X0 and the enclosure must be removed. Due to high inrush currents that may be created in these applications, it is recommended that you do not reverse-feed transformers rated more than 75 kVA. The preferred solution is to purchase an Eaton step-up transformer designed specifically for your application.

### Can transformers be connected in parallel?

Yes, with certain restrictions. For single-phase transformers being connected in parallel, the voltages and impedances of the transformers must be equal (impedances must be within 7.5% of each other). For three-phase transformers, the same restrictions apply as for single-phase transformers, plus the phase shift of the transformers must be the same. For example, a delta-wye-connected transformer (30° phase shift) must be connected in parallel with another delta-wye-connected transformer, not a delta-delta-connected transformer (0° phase shift).

**Why is the impedance of a transformer important?**

The impedance of a transformer is important because it is used to determine the interrupting rating and trip rating of the circuit protection devices on the load side of the transformer. To calculate the maximum short-circuit current on the load side of a transformer, use the following formula:

$$\frac{\text{Maximum Short-Circuit Load Current (Amps)}}{\text{Load Current (Amps)}} = \frac{\text{Full Load Current (Amps)}}{\text{Transformer Impedance}}$$

Full load current for single-phase circuits is:

$$\frac{\text{Nameplate Volt-Amps}}{\text{Load (output) Voltage}}$$

and for three-phase circuits the full load current is:

$$\frac{\text{Nameplate Volt-Amps}}{\text{Load (output) Volts} \times \sqrt{3}}$$

Example: For a standard three-phase, 75 kVA transformer, rated 480 V delta primary and 208Y/120 V secondary (catalog number V48M28T75J) and impedance equal to 5.1%, the full load current is:

$$\frac{75,000 \text{ VA}}{208 \text{ V} \times 1.732} = 208.2 \text{ A}$$

The maximum short-circuit load current is:

$$\frac{208.2 \text{ A}}{0.051} = 4082.4 \text{ A}$$

The circuit breaker or fuse on the secondary side of this transformer would have to have a minimum interrupting capacity of 4083 A at 208 V. NEMA ST-20 (1992).

A similar transformer with lower impedance would require a primary circuit breaker or fuse with a higher interrupting capacity.

**What clearances are required around transformers when they are installed?**

All dry-type transformers depend upon the circulation of air for cooling; therefore, it is important that the flow of air around a transformer not be impeded. Many Eaton transformers require a minimum clearance of 6 inches from panels with ventilation openings. However, small kVA DOE 2016 efficient ventilated transformers are UL approved to be installed with just 2 inches clearance, while large kVA transformers require 12 inches or more clearance. In compliance with NEC 450.9, Eaton’s ventilated transformers have a note on their nameplates identifying the minimum required clearance from the ventilation openings and walls or other obstructions. This clearance only addresses the ventilation needs of the transformer. There may be additional local codes and standards that affect installation clearances.

Transformers should not be mounted in such a manner that one unit will contribute to the additional heating of another unit, beyond allowable temperature limits, for example, where two units are mounted on a wall one above the other.

**How Can I Reduce Transformer Sound Levels?**

All transformers emit some audible sound due mainly to the vibration generated in their core by alternating flux. NEMA ST-20 (2014) defines the maximum average sound levels for transformers.

**Table 19.1-31. NEMA ST-20 (2014) Maximum Audible Sound Levels for 600 V Class Transformers (dBA)**

Equivalent Winding kVA Range	Average Sound Level, Decibels			
	Self-Cooled Ventiladed			Self-Cooled Sealed
	A	B	C	
	K Factor = 1 K Factor = 4 K Factor = 9	K Factor = 13 K Factor = 20	Forced Air When Fans Running	D
3.00 and below	40	40	67	45
3.01 to 9.00	40	40	67	45
9.01 to 15.00	45	45	67	50
15.01 to 30.00	45	45	67	50
30.01 to 50.00	45	48	67	50
50.01 to 75.00	50	53	67	55
75.01 to 112.50	50	53	67	55
112.51 to 150.00	50	53	67	55
150.01 to 225.00	55	58	67	57
225.01 to 300.00	55	58	67	57
300.01 to 500.00	60	63	67	59
500.01 to 700.00	62	65	67	61
700.01 to 1000.00	64	67	67	63
Greater than 1000	Consult factory			

**Note:** Consult factory for nonlinear requirements exceeding a K-factor rating of 20. When the fans are not running, columns A and B apply. Sound levels are measured using the A-weighted scale (dBA).

All Eaton transformers are designed to have audible sound levels lower than those required by NEMA ST-20 (2014). However, consideration should be given to the specific location of a transformer and its installation to minimize the potential for sound transmission to surrounding structures and sound reflection. The following installation methods should be considered:

1. If possible, mount the transformer away from corners of walls or ceilings. For installations that must be near a corner, use sound-absorbing materials on the walls and ceiling if necessary to eliminate reflection.
2. Provide a solid foundation for mounting the transformer and use vibration dampening mounts if not already provided in the transformer. Eaton’s ventilated transformers contain a built-in vibration dampening system to minimize and isolate sound transmission. However, supplemental vibration dampening mounts installed between the floor and the transformer may provide additional sound dampening.
3. Make electrical connections to the transformer using flexible conduit.
4. Locate the transformer in an area where audible sound is not offensive to building inhabitants.
5. Install “low sound” transformers (up to 5 dB below NEMA ST-20 [2014] sound limits).

---

*This page intentionally left blank.*