

TERMINAL LUGS			
AMPERES	MAX WIRE	MIN WIRE	TYPE
30	#6 AWG	#12 AWG	AL
30	#6 AWG	#14 AWG	CU

SEISMIC NOTES:
 USE (4) 1/4" DIA GRADE 5 STEEL MOUNTING BOLTS @ HOLES AA
 MAX CONFIGURED WEIGHT 14 LB FOR THE PURPOSE OF
 DETERMINING SEISMIC ANCHORAGE REQUIREMENTS. FOR ALL OTHER
 APPLICATIONS, CONTACT SCHNEIDER ELECTRIC.

NEMA TYPE 12/3R

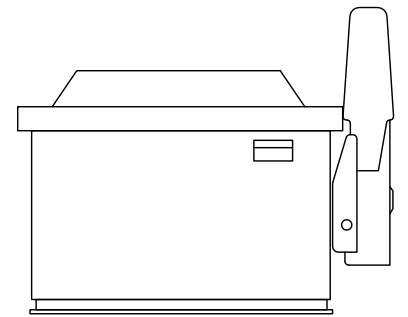

*FROM SIDE OF ENCLOSURE

DUAL DIMENSIONS: INCHES
MILLIMETERS

CATALOG NUMBER	VOLTAGE RATINGS	AMPERAGE RATINGS	WIRING DIAG	HORSEPOWER RATINGS															
				240VAC				480VAC				600VAC				250 VDC	600 VDC		
				STD		MAX		STD		MAX		STD		MAX					
1Ø	3Ø	1Ø	3Ø	1Ø	3Ø	1Ø	3Ø	1Ø	3Ø	1Ø	3Ø	1Ø	3Ø	STD	MAX				
H221AWK	240VAC,250VDC	30	A	1 1/2 ●	3 †	3 ●	7 1/2 †	-	-	-	-	-	-	-	-	-	-		
H321AWK	240VAC,250VDC	30	B	1 1/2 ▲	3 ■	3 ▲	7 1/2 ■	-	-	-	-	-	-	-	-	-	-		
H361AWK	600VAC,600VDC	30	B	-	-	-	-	3 ▲	5 ■	7 1/2 ▲	15 ■	-	7 1/2	-	20	5 ▲	-	10 ▲	15
HU361AWK	600VAC,600VDC	30	C	-	-	5 ▲	10 ■	-	-	7 1/2 ▲	20 ■	-	-	10 ▲	30	-	5	-	15 ▲
HU361AWKEI	600VAC,600VDC	30	C	-	-	5 ▲	10 ■	-	-	7 1/2 ▲	20 ■	-	-	10 ▲	30	-	5 ▲	-	15 ▲

NOTES;
 UL LISTED - E2875
 FINISH - GRAY BAKED ENAMEL
 ALL NEUTRALS - INSULATED
 WHEN MOUNTING THESE SWITCHES, ALLOW 3.00/[76] MIN CLEARANCE
 BETWEEN ENCLOSURES FOR OPENING OF SIDE HINGED DOOR.
 ▲ USE BOTH OUTER SWITCHING POLES
 ● USE BOTH SWITCHING POLES
 ■ IF CORNER GROUNDED DELTA, INSTALL NEUTRAL AND USE OUTER SWITCHING POLES
 FOR UNGROUNDED CONDUCTORS.
 † FOR CORNER GROUNDED DELTA ONLY, USE OUTER SWITCHING POLES FOR UNGROUNDED CONDUCTORS.

HEAVY DUTY SAFETY SWITCHES VISIBLE BLADE TYPE 30 AMPERE - SERIES F6 ENCLOSURE - NEMA TYPE 12/3R	 by Schneider Electric
	DWG# 2231S NO.