

Low Voltage

PowerPact Multistandard

Circuit breakers 15 A - 600 A



Schneider
Electric™

• WEB2 cat.2015



Over 75% of Schneider Electric
manufactured products awarded
Green Premium eco-mark



Green Premium, stamping the most
eco-friendly products of the industry



**Green
Premium**[™]
Product

With Green Premium, Schneider Electric commits to be transparent disclosing extensive and reliable information on environmental impacts of its products:

Green Premium is the only label allowing you to develop effectively an environmental policy and to promote it, while preserving your business efficiency.

It guarantees compliance with the most up-to-date environmental regulations, but it is more than this.

With Green Premium eco-mark, Schneider Electric helps you:

- Calculate the carbon footprint of the solutions you offer
- Ensure full regulation compliance about substances and chemical components
- Deliver all appropriate information to certify eco-design of your solutions
- Easily manage products end of life, while ensuring optimized recycling.

RoHS

Schneider Electric applies RoHS requirements to all its products and worldwide, even for the numerous ones which are not in the scope of the regulation. Compliance certificates are available for all products involved.

REACH

Schneider Electric applies REACH regulation worldwide, and releases all information about presence of Substances of Very High-Concern (SVHC) in its products.

PEP: Product Environmental Profile

For all its products, Schneider Electric publishes the most complete set of environmental data, including carbon footprint and energy consumption for each of the life cycle phases, in compliance with ISO 14025 PEPecopassport program.

EoLI: End of Life Instructions

Available at a click, these documents provide:

- Recyclability rates of the products
- Information to mitigate personnel hazards during dismantling and before recycling operations
- Parts identification either for re-use, or for selective treatment to mitigate environmental hazards, or incompatibility with usual recycling process.



Discover what we
mean by green
and

Check a product!

PowerPact™ Multistandard

The PowerPact Multistandard circuit breakers are designed to protect electrical systems from damage caused by overloads and short circuits. Multistandard circuit breakers are available with either thermal-magnetic or Micrologic electronic trip units. L-frame circuit breakers are available with Micrologic electronic trip unit. Multistandard circuit breakers with thermal-magnetic trip units contain individual thermal (overload) and instantaneous (short circuit) sensing elements in each pole. The amperage ratings of the thermal trip elements are calibrated at 104 °F (40 °C) free air ambient temperature. Per the National Electric Code® (NEC®) and the Canadian Electrical Code, standard circuit breakers may only be applied continuously at up to 80 % of their rating. Circuit breakers rated for 100 % operation are available but require specially-designed enclosures and 194 °F (90 °C) rated wire.



Monitoring and management

PowerPact is a single device, which contains a monitoring unit to control energy consumption and power.



Integrated monitoring

> The new PowerPact range incorporates Micrologic electronic trip units in the circuit breaker, offering both:

- an accurate power monitoring unit,
- a highly reliable protective device.

> A Micrologic electronic tripping device combines next-generation sensors:

- an "iron" sensor for the power supply to the electronics,
- an "air" sensor (Rogowski coils) for measurement, guaranteeing high accuracy.

> These electronic systems are designed to withstand high temperatures (105 °C), ensuring reliability under severe operating conditions.

> The originality lies in how PowerPact measures, processes and displays data, either directly on screen, on the switchboard front panel, or via a monitoring system.

-10%

Monitoring consumption can reduce energy costs by as much as 10 %.

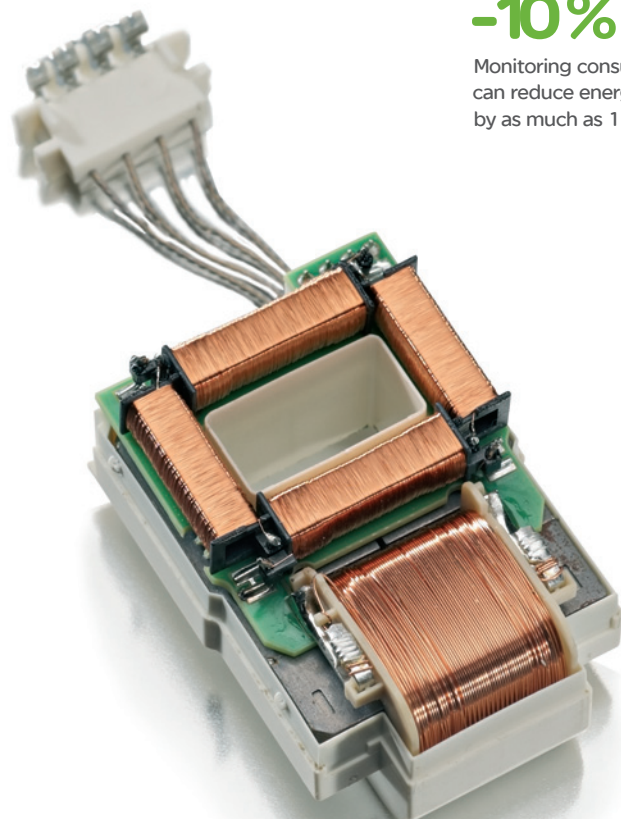

Accessibility of information... ..for power monitoring

To keep costs under control and ensure service continuity, relevant information must be available in real time:

- > a kilowatt-hour meter helps optimise costs and their allocation,
- > harmonic distortion rate shows the quality of electrical supply,
- > alarm notification secures operational control and maintenance planning,
- > event logs and tables, activated continuously, ensure the installed equipment base operates correctly, so energy efficiency is maximized.

> Together with power monitoring software, the PowerPact Modbus communication interface provides operators with a parameter set and tools that make system monitoring very easy.

> Operators have real-time data to control energy availability, to monitor power supply quality, to optimise consumption of different applications or zones, reducing load peaks and continuously supplying priority loads, and to draw up maintenance schedules.

> A software utility (RSU) allows protection and alarm configuration, in addition to testing communications with all installed devices.

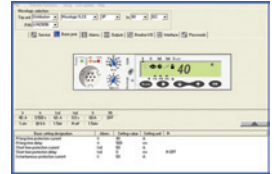

Supervision software



Measurement functions are controlled by an additional microprocessor.

Protection functions are electronically managed independently of measurement functions.

An ASIC (Application-Specific Integrated Circuit) is common to all trip units, which boosts immunity to conducted or radiated interference and increases reliability.

PowerPact Multistandard

Applications

PowerPact Multistandard circuit breakers offer high performance and a wide range of interchangeable trip units to protect most applications. Electronic trip units provide highly accurate protection with wide setting ranges and can integrate measurement, metering and communication functions.

They can be combined with the front display module (FDM) to provide functions similar to a power meter.



With Micrologic circuit breakers

Direct access to energy management

The new generation PowerPact with Micrologic circuit breakers set the standard with direct access to energy management.

Integrated metering enhances their protective functions.

For the first time, Schneider Electric users can monitor energy from 15 A to 600 A, offering new performance in a remarkably compact device.

- > Smart - A meter in every breaker
- > Safe - Combines safety and performance in one compact device
- > Simple - Easy to select, install, and use.



Increased
energy
availability



Safety and
protection



Energy
measurement
and control

Flexible configurations

The PowerPact Multistandard circuit breakers may be configured with lugs, bus bar connections, rear connections...

Devices with the Micrologic electronic trip unit provide adjustable protection settings for greater system flexibility. In addition to electronic protection, Micrologic trip units allow users to monitor both energy and power. Through direct access to in-depth information and networking using open protocols, PowerPact circuit breakers with Micrologic trip units let operators optimize the management of their electrical installations.

> Field installable accessories and trip units

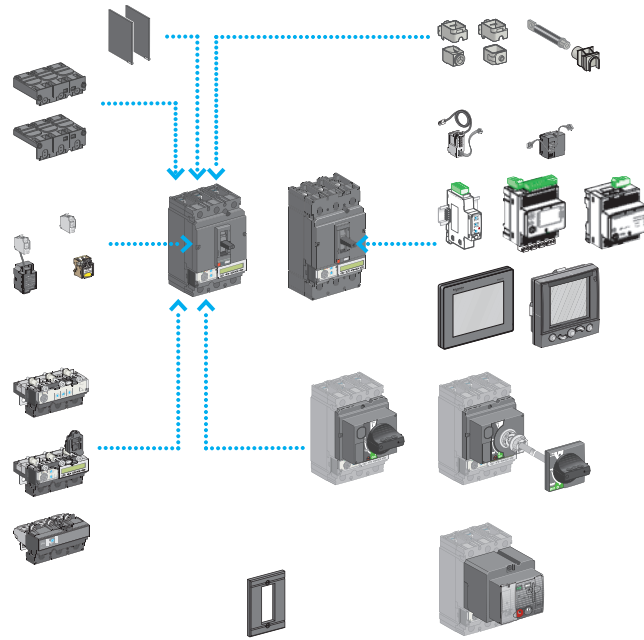

Far more than a circuit breaker, these circuit breakers are a measurement and communication tool ready to meet energy-efficiency needs through optimized power requirements, increased energy availability, and improved installation management.

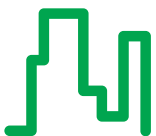
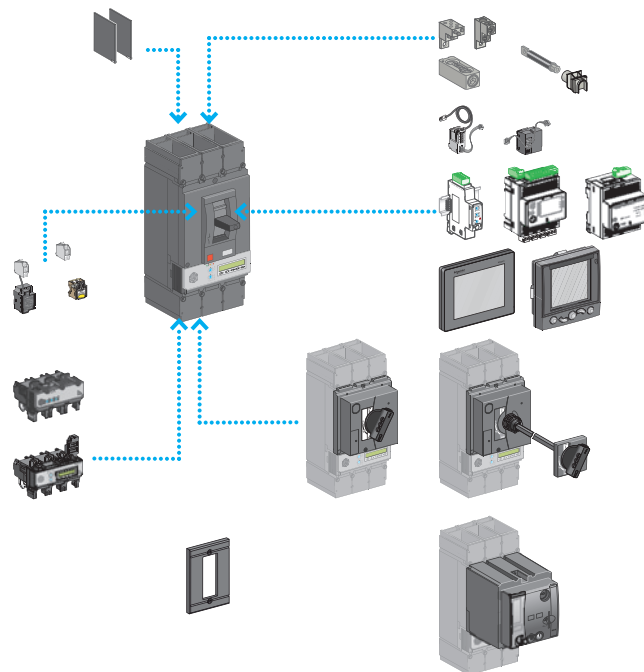

Buildings



Datacentre

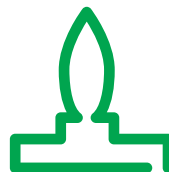

Oil and gas

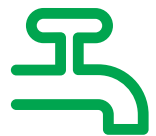

Water

Catalogue numbering...

...thermal magnetic circuit breaker

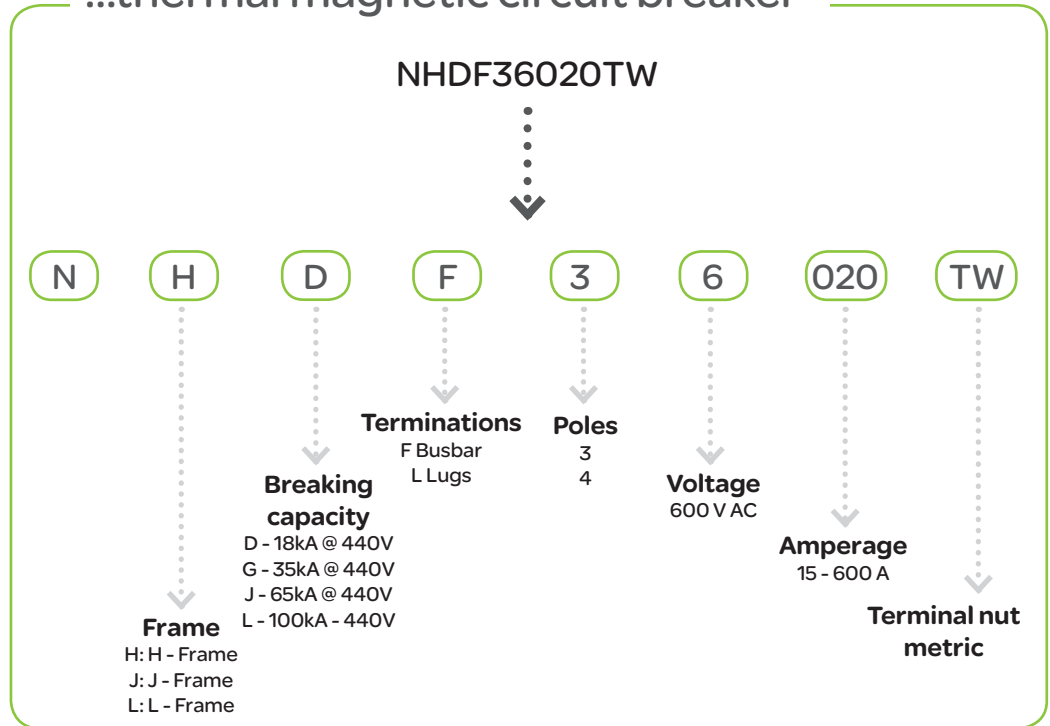

Example

> Customer needs 20 A breaker 18 kA / 440 V AC

Ordered	Qty
1. With metric terminal nuts	
NHDF36020TW	1
2. With english terminal nuts	
NHDF36020TW	1
S37444 replace in field	2
3. With mechanical lugs	
NHDL36020	1



...electronic trip unit

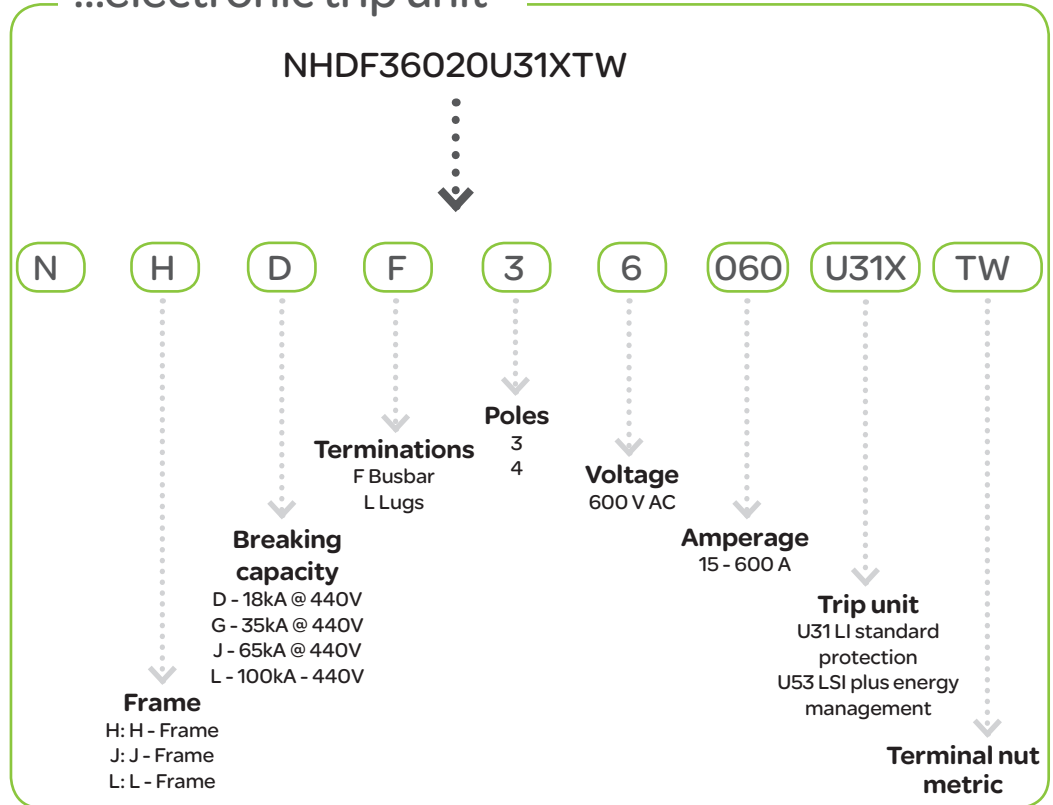

Example

> Customer needs 20 A breaker 18 kA / 440 V AC

Ordered	Qty
1. With standard trip unit and metric terminal nuts	
NHDF36060U31XTW	1
2. With standard trip unit and mechanical lugs	
NHDL36060U31X	1
3. With energy trip unit and metric terminal nuts	
NHDF36060U53XTW	1
4. With energy trip unit and mechanical lugs	
NHDL36060U53X	1

Energy management using the Enerlin'X System

Use the Enerlin'X communication system to connect your building to real savings in three steps:

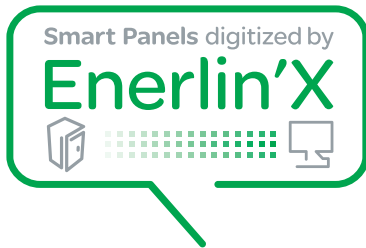

1 Measure
Embedded and stand-alone metering & control

2 Connect

- > Integrated communication interfaces
- > Ready to connect to energy management platforms

3 Save

- > Data-driven energy efficiency actions
- > Real-time monitoring and control
- > Access to energy and site information through on-line services



Smart Panels connect you to energy savings



1 MEASURE

Enerlin'X communication systems mean visible information

Grouping most of the electrical protection, command and metering components, the switchboards are now significant sources of data locally displayed and sent via communication networks.

2 CONNECT

Enerlin'X communication systems use reliable, simple-to-install-and-use displays, and Ethernet and Modbus interfaces

Information is safely transmitted through the most efficient networks: Information is safely transmitted through the most efficient networks:

- Modbus SL inside switchboards, between components,
- Ethernet, on cable or WiFi, inside the building and connecting switchboards and computers,
- Ethernet or GPRS, for access to on-line services by Schneider Electric,
- Energy experts, no matter where they are located, can now provide advise based on the updated data of the building.

3 SAVE



On-site real-time monitoring and control

The FDM128 touch screen display connected to the Ethernet:

- shows essential electrical information and alarms concerning the electrical network,
- allows control (open, close, reset...) of various equipment,

The FDM128 touch screen provides real-time value checking and control, directly on the front panel of the main switchboard.

On a PC display with common browser:

- shows monitoring web pages hosted into the local Ethernet interface,
- alarm events generate automatic email notifications,
- allows control (open, close, reset...) of various equipments.

The data is displayed graphically or recorded into files for optimizing the use of energy in the building.

As an example, the data can help validate the change of temperature settings, time scheduling in a Building Management System or other automated devices.

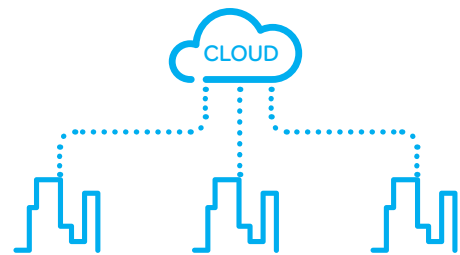

On-line Energy Management services

StruXureWare Energy Operation

automates data collection using an open, scalable, and secure energy management information system.

With the help of the Schneider Electric energy management services team, data is turned into information to enable customers to understand their facilities' performance on an ongoing basis.

Energy Operation leverages companies' current investments in their existing systems, and can be used to communicate advanced results and performance to a broad audience for a shared understanding throughout an organization.

Enerlin'X Communication System Components

PowerPact Circuit Breakers with Micrologic Trip Units

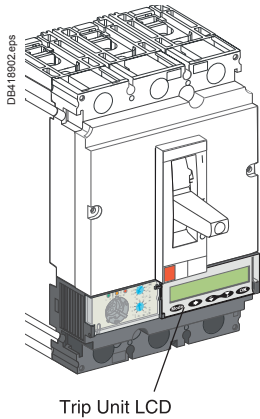

PowerPact Circuit Breakers with Micrologic Trip Units

Ammeter E

- > Micrologic 5 E selective protection.

Displays

FDM121

- > One-to-one front display module
- > See [page A-18](#) for more information.



FDM128

- > One-to-eight front display module
- > See [page A-19](#) for more information.



Communication

- > PowerPact and Compact circuit breakers in a communication network
- > I/O application module
- > IFE: Ethernet interface module
- > IFM: Modbus interface module.



I/O Module



IFE Module



IFM Module

See [page 94](#) for more information.





	Functions and characteristics	A-1
---	-------------------------------	-----

	Installation recommendations	B-1
---	------------------------------	-----

	Dimensions and connections	C-1
---	----------------------------	-----

	Wiring diagrams	D-1
---	-----------------	-----

	Additional characteristics	E-1
---	----------------------------	-----

	Catalogue numbers	F-1
---	-------------------	-----

	Glossary	G-1
---	----------	-----

Introduction	
General characteristics of the PowerPact range	A-2
Circuit breakers	A-3
Characteristics and performance of PowerPact circuit breakers	A-4
PowerPact Multistandard trip units	A-6
PowerPact trip units	A-7
Overview of trip units for PowerPact	A-8
Protection of distribution system	
Micrologic 1.3 M electronic trip units for instantaneous protection only (L-Frame circuit breakers only)	A-10
Micrologic 2.2 M and 2.3 M Electronic trip units	A-11
Micrologic 3 trip units	A-12
Micrologic 5 E trip units	A-14
Micrologic 5 E "Energy"	A-16
Power Meter functions	A-18
Operating-assistance functions characteristics	A-21
PowerPact H-, J-, and L-frame circuit breakers	
Energy Management	A-23
Switchboard-display functions	
Micrologic E trip unit with COM option (ULP)	A-24
FDM121 Connections	
Communication components and connections	A-26
Switchboard-display functions	
Micrologic E trip unit with COM Ethernet gateway	A-28
FDM128 Connections	
Communication components and connections	A-30
Enerlin'X communication system	
Products overview	A-31
Communication	
Communication wiring system	A-33
Overview of functions	A-34
IFE Ethernet interface	A-35
IFM Modbus communication interface	A-37
I/O application module	A-39
Communication	A-41
Communications modules, IFM and IFE	A-41
Electrical Asset Manager Configuration Engineering tool	A-42
Accessories for Micrologic trip units	A-44
Accessories and auxiliaries	A-46
Overview of PowerPact H- and J- frame	A-46
Overview of PowerPact L- frame	A-47
Device installation	A-48
Insulation of live parts	A-51
Selection of auxiliaries for PowerPact 150 / 250 A H-Frame and J-Frame	A-52
Selection of auxiliaries for PowerPact 400 / 600 A L-Frame	A-54
Indication contacts	A-56
Remote tripping	A-58
Rotary handles	A-59
Motor mechanism	A-60
Locks	A-61
Sealing accessories	A-62
Distribution system	A-63
Plates for mounting on 60 mm busbar	A-63
Busbar support	A-64
Choice of mounting plates	A-65
<i>Installation recommendations</i>	
> B-1	
<i>Dimensions</i>	
> C-1	
<i>Wiring diagrams</i>	
> D-1	
<i>Additional characteristics</i>	
> E-1	
<i>Catalogue numbers</i>	
> F-1	
<i>Glossary</i>	
> G-1	

Introduction

General characteristics of the PowerPact range

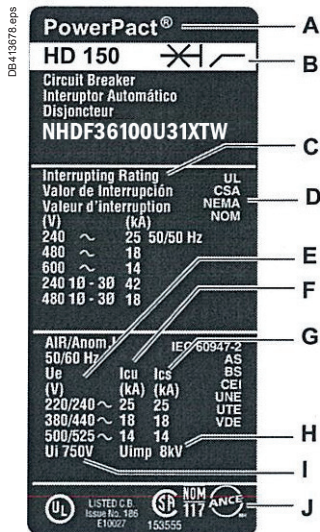

Characteristics indicated on the faceplate label:

- A. Circuit breaker type
- B. Circuit breaker disconnect symbol
- C. Performance levels
- D. Standards
- E. U_e : Operating voltage per IEC
- F. I_{cu} : Ultimate breaking capacity per IEC
- G. I_{cs} : Service breaking capacity per IEC
- H. U_{imp} : Rated impulse withstand voltage per IEC
- I. U_i : Insulation voltage per IEC
- J. Certification marks

Note: when the circuit breaker is equipped with an extended rotary handle, the door must be opened to view the faceplate.

Codes and standards

H- and J-frame circuit breakers, automatic switches and electronic motor circuit protectors are manufactured and tested in accordance with the following standards.

Note: apply circuit breakers according to guidelines detailed in the National Electric Code (NEC) and other local wiring codes.

Codes and standards (Domestic)

PowerPact Multistandard circuit breakers	PowerPact Multistandard switches
UL 489 ⁽¹⁾	UL 489 ⁽³⁾
IEC 60947-2	IEC 60947-3
CSA 22.2 No. 5 ⁽²⁾	CSA C22.2C No. 5 ⁽⁴⁾
Federal Specification W-C-375B/GEN	Federal Specification W-C-375B/GEN
NEMA AB1	NEMA AB1
NMX J-266	NMX J-266
CCC	CE Marking
CE Marking	-

⁽¹⁾ PowerPact H- and J frame circuit breakers are in UL File E10027. PowerPact L-frame circuit breakers are in UL File E63335.

⁽²⁾ PowerPact H- and J frame circuit breakers are in CSA File LR40970. PowerPact L-frame circuit breakers are in CSA File LR.

⁽³⁾ PowerPact H- and J frame switches are in UL File E87159.

⁽⁴⁾ PowerPact H- and J frame switches are in CSA File LR32390.

Circuit breakers

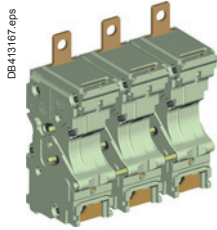
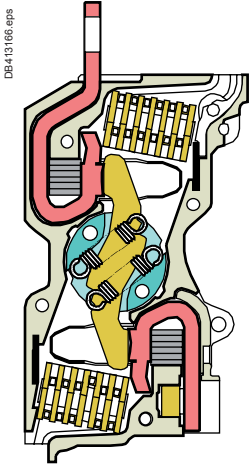

Dual-break rotating contacts

All PowerPact Multistandard circuit breakers are equipped with dual-break rotating contacts that reduce the amount of peak current during a short circuit fault. This reduces the let-through currents and enhances equipment protection.

Reduced let-through currents

The moving contact has the shape of an elongated “S” and rotates around a floating axis. The shape of the fixed and moving contacts are such that the repelling forces appear as soon as the circuit reaches approximately 15 times I_n .

Due to the rotating movement, repulsion is rapid and the device greatly limits short-circuit currents, whatever the interrupting level of the unit. The fault current is extinguished before it can fully develop. Lower let-through currents provide less peak energy, reducing the required bus bar bracing, lowering enclosure pressure, and delivering improved series or combination ratings.

Internal operating mechanism

PowerPact Multistandard circuit breakers have an over-center toggle mechanism providing quick-make, quick-break operation. The operating mechanism is also trip-free, which allows tripping even when the circuit breaker handle is held in the “ON” position.

Internal cross-bars provide common opening and closing of all poles with a single operating handle.

All PowerPact circuit breakers have an integral push-to-trip button in the cover to manually trip the circuit breaker. This should be used as part of a regular preventive maintenance program.

Handle position indication

The circuit breaker handle can assume any of three positions, ON, tripped or OFF as shown.

The center tripped position provides positive visual indication that the circuit breaker has tripped.

The circuit breaker can be reset by first pushing the handle to the extreme “OFF” position. Power can then be restored to the load by pushing the handle to the “ON” position.

Current limiting

The current limiting attributes of PowerPact Multistandard circuit breakers provide greater protection for downstream devices by limiting the let-through current in the event of a fault. The current-limiting capabilities of HJ, LJ, LL and JJ frame circuit breakers are documented with Underwriters Laboratories and Canadian Standards Association. These current-limiting circuit breakers ship with a label that identifies them as UL/CSA current limiting circuit breakers. (The HD/HG, LD/LG and JD/JG circuit breakers do not carry the UL current limiting label).

The trip curves with let-through data are available in the trip curve section in this catalog.

Please note that as let-through curves for UL Listed/CSA Certified current-limiting circuit breakers, these curves are maximum let-through values.

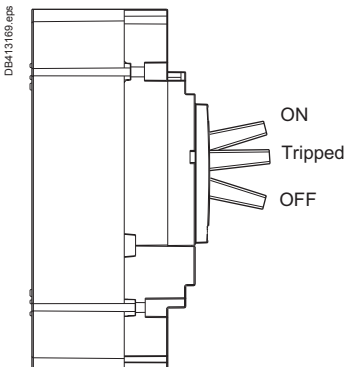
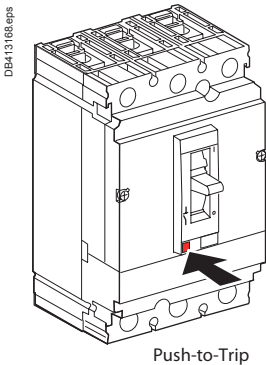

Introduction

Characteristics and performance of PowerPact circuit breakers



PowerPact H-frame.



PowerPact J-frame.



PowerPact L-frame.

Circuit breaker ratings

The interrupting rating is the highest current at rated voltage the circuit breaker is designed to safely interrupt under standard test conditions. Circuit breakers must be selected with interrupting ratings equal to or greater than the available short-circuit current at the point where the circuit breaker is applied to the system (unless it is a branch device in a series rated combination). Interrupting ratings are shown on the front of the circuit breaker.

Reverse feeding of circuit breakers

The standard unit-mount Multistandard circuit breakers have sealed trip units and may be reverse fed.

Circuit breaker

Circuit breaker type

Number of poles

Amperage range (A)

UL 489 circuit breaker ratings

UL/CSA/NOM (kA rms)	240 V AC
	480 V AC
	600 V AC

IEC 947-2 circuit breaker ratings

Ultimate breaking capacity (Icu) (kA rms)	220/240 V AC
	380/415 V AC
	440/480 V AC
	500/525 V AC

Service breaking capacity (Ics)	% Icu
---------------------------------	-------

Insulation voltage	V _i
Impulse withstand voltage	V _{imp}
Operational voltage	V _e
Sensor rating	I _n
Utilization category	-

Operations (Open-Close Cycles)

Without current

With current

Protection and measurements

Overload/short-circuit protection	Thermal-magnetic
	Electronic
Display / I, V, f, P, E, THD measurements / interrupted-current measurement	
Options	Front display module (FDM121)
	Operating assistance
	Counters
	Histories and alarms
	Metering Com
	Device status/control com

Dimensions / Weight / Connections

Dimensions 3P (unit mount) mm. (in)	Height
	Width
	Depth
Weight 3P - kg (lb.)	
Connections / Terminations	Unit mount
	Rear connection
	Plug-In
	Optional lugs

150 A H-Frame			250 A J-Frame			400 A L-Frame			600 A L-Frame			
HD	HG	HJ	JD	JG	JJ	LD	LG	LJ	LD	LG	LJ	LL
3	3	3	3	3	3	3	3	3	3	3	3	3
15-150			70-250			70-400			200-600			
25	65	100	25	65	100	25	65	100	25	65	100	125
18	35	65	18	35	65	18	35	65	18	35	65	100
14	18	25	14	18	25	14	18	25	14	18	25	50
25	65	100	25	65	100	25	65	100	25	65	100	125
18	35	65	18	35	65	18	35	65	18	35	65	100
18	35	65	18	35	65	18	35	65	18	35	65	100
14	18	25	14	18	25	14	18	25	14	18	25	50
100 %			100 %			100 %			100 %			
750 V AC			750 V AC			750 V AC			750 V AC			
8 kV AC			8 kV AC			8 kV AC			8 kV AC			
690 V AC			690 V AC			690 V AC			690 V AC			
150 A			250 A			400 A			600 A			
A			A			A			A			
4000			5000			5000			5000			
4000			1000			1000			1000			
■	■	■	■	■	■	-	-	-	-	-	-	-
■	■	■	■	■	■	■	■	■	■	■	■	■
■	■	■	■	■	■	■	■	■	■	■	■	■
■	■	■	■	■	■	■	■	■	■	■	■	■
■	■	■	■	■	■	■	■	■	■	■	■	■
■	■	■	■	■	■	■	■	■	■	■	■	■
■	■	■	■	■	■	■	■	■	■	■	■	■
■	■	■	■	■	■	■	■	■	■	■	■	■
163 (6.4)			191 (7.5)			340 (13.38)			340 (13.38)			
104 (4.1)			104 (4.1)			140 (5.51)			140 (5.51)			
86 (3.4)			86 (3.4)			110 (4.33)			110 (4.33)			
2.2 (4.8)			2.4 (5.3)			6.0 (13.2)			6.2 (13.7)			
■			■			■			■			
■			■			■			■			
■			■			■			■			
■			■			■			■			

Thermal-magnetic or electronic trip unit ?

Thermal-magnetic trip units protect against overcurrents and short-circuits using tried and true techniques. For applications requiring installation optimization and energy efficiency, electronic trip units offering more advanced protection functions combined with measurements.

Trip units using digital electronics are faster as well as more accurate. Wide setting ranges make installation upgrades easier. Designed with processing capabilities, Micrologic trip units can provide measurement information and device operating assistance. With this information, users can avoid or deal more effectively with disturbances and can play a more active role in system operation. They can manage the installation, anticipate events and plan any necessary servicing.

Accurate measurements for complete protection

PowerPact Multistandard circuit breakers devices offer excellent measurement accuracy from 15 amperes on up to the short-circuit currents. This is made possible by a new generation of current transformers combining “iron-core” sensors for self-powered electronics and “air core” sensors (Rogowski coils) for measurements. The protection functions are managed by an ASIC (Application Specific Integrated Circuit) component that is independent of the measurement functions. This independence ensures immunity to conducted and radiated disturbances and a high level of reliability.

Numerous security functions

Torque-limiting screws

The screws secure the trip unit to the circuit breaker. When the correct tightening torque is reached, the screw heads break off. Optimum tightening avoids any risk of temperature rise. A torque wrench is no longer required.

“Ready” LED for a continuous self-test

The LED on the front of the electronic trip units indicates the result of the self-test running continuously on the measurement system and the tripping release. As long as the green LED is flashing, the links between the CTs, the processing electronics and the tripping mechanism are operational. The circuit breaker is ready to protect. A minimum current of 15 to 50 A, depending on the device, is required for this indication function.

A patented dual adjustment system for protection functions

Available on Micrologic trip units, the system consists of:

- an adjustment using rotary switches sets the maximum value
- an adjustment using the keypad or made remotely, fine-tunes the setting. This setting may not exceed the first one. It can be read directly on the Micrologic trip unit screen, to within one ampere and a fraction of a second.

PowerPact trip units

Available trip units

■ PowerPact™ H-, J-, and L-Frame circuit breakers offer a range of thermal-magnetic and Micrologic™ electronic trip units. Thermal-magnetic trip units are designed to open automatically under overload or short circuit. H-frame and J-frame thermal-magnetic circuit breakers contain individual thermal (overload) and instantaneous (short circuit) sensing elements in each pole.

■ Micrologic electronic trip units provide intelligent operation, with wide setting ranges make installation upgrades easier. Designed with processing capabilities, Micrologic trip units can provide measurement information and device operating assistance to supply all of the information required to manage the electrical installation and optimize energy use.

Micrologic trip units offer excellent measurement accuracy, using a new generation of current transformers combining “iron-core” sensors for self-powered electronics and “air-core” sensors (Rogowski coils) for measurements. The protection functions are managed by an ASIC component that is independent of the measurement functions. This independence ensures immunity to conducted and radiated disturbances and a high level of reliability.



An LED on the front of the electronic trip units indicates the result of the self-test running continuously on the measurement system and the tripping release. When the green LED is flashing, the links between the CTs, the processing electronics and the Mitop release are operational. The circuit breaker is ready to protect.

A minimum current of 15 to 50 A, depending on the device, is required for this function.

The dual adjustment for protection functions on Micrologic 5 consists of:

- an adjustment using rotary switches sets the maximum value
- an adjustment, made using the keypad or remotely, fine-tunes the setting.

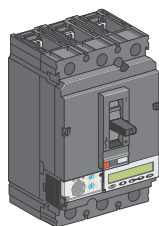
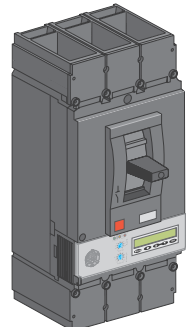
This setting may not exceed the first one. It can be read directly on the Micrologic screen, to within one ampere and a fraction of a second.

Understanding the names of Micrologic electronic trip units				
	Protection	Frame	Measurements	Applications
	<p>3: LI</p> <p>5: LSI</p> <p>L: Long time</p> <p>S: Short time</p> <p>I: Instantaneous</p>	<p>H- and J-frame</p>  <p>L-frame</p> 	 	<p>Distribution</p>

Note: all the trip units have a transparent sealable cover that protects access to the adjustment rotary switches.

TM thermal-magnetic trip units can be used on PowerPact H and J-frame circuit breakers with interrupting levels D/G/J. Thermal-magnetic trip units are available in factory sealed.

Thermal-magnetic trip units

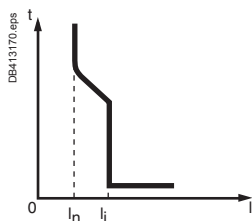

H-Frame Trip Curve
 (In) Fixed threshold thermal protection against overload.
 (Ii) Fixed threshold instantaneous protection against short circuits.

PowerPact H- and J-Frame

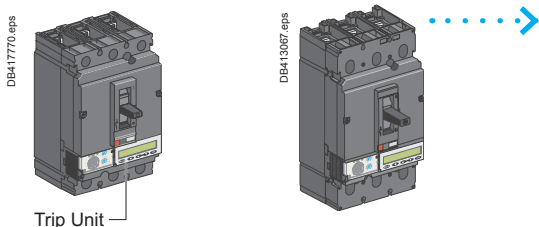

Circuit breaker and trip units

Distribution Protection Thermal-Magnetic T-M



H - non adjustable



J - adjustable

Distribution Protection SI

Micrologic 2.2 M and 2.3 M

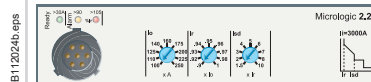

PowerPact L-Frame

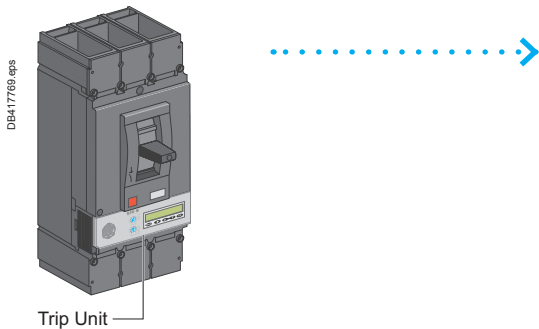

Distribution Protection Thermal-Magnetic T-M

N/A

Distribution Protection SI

Micrologic 2.3 M

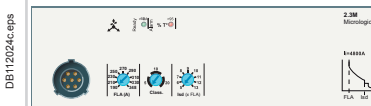

Settings and indications

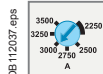

Adjustment and reading
 Pick-up set in amps using dials
 Non-adjustable time delay

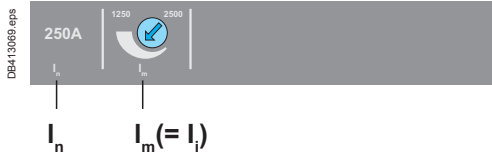

Distribution Protection LI

Micrologic 3.2



Distribution Protection LSI + Energy Monitoring

Micrologic 5.2E



Distribution Protection LI

Micrologic 3.3



Distribution Protection LSI + Energy Monitoring

Micrologic 5.3E

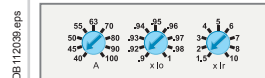

Adjustment and reading
Pick-up set in amps with fine adjustment using dials
Non-adjustable time delay



Front indications

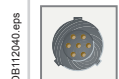

Test connector
Self test

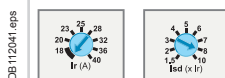

Adjustment and reading
Pick-up set in amps



Fine adjustment via keypad



Adjustable time delays



Front indications



Test connector
Self test



FDM121 | **FDM128**
Connection to switchboard display unit

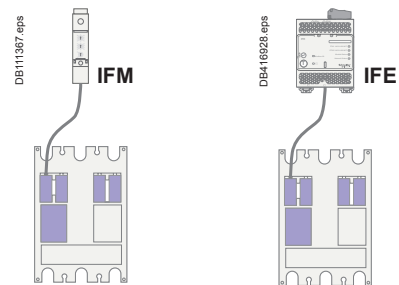

Communication to Modbus

Protection of distribution system

Micrologic 1.3 M electronic trip units for instantaneous protection only (L-Frame circuit breakers only)

Micrologic 1.3 M trip units are used in 3-device motor-feeder solutions on PowerPact L-frame circuit breakers with performance levels G/J/L. They provide short-circuit protection for motors up to 250 kW at 400 V.

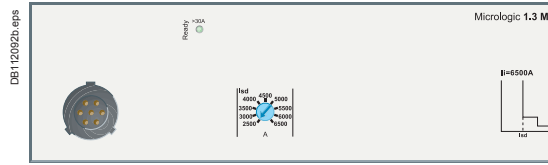

Micrologic 1.3 M trip units provide instantaneous protection only, using electronic technology. They are dedicated to 600 A 3-pole (3P 3D) circuit breakers or 4-pole circuit breakers with detection on three poles (4P, 3D). They are especially used in 3-pole versions for motor protection.

Circuit breakers equipped with Micrologic 1.3 M trip units, without thermal protection, are used in certain applications to replace automatic switches. Micrologic 1.3 M trip units are available on PowerPact L-frame circuit breakers only.

They also provide the benefits of electronic technology:

- accurate setting
- tests
- "Ready" LED.

Circuit breakers with a Micrologic 1.3 M trip units are combined with an overload relay and a contactor.

Protection settings are made using a rotary switch.

Protection version

Three pole (3P) : three pole frame circuit breakers equipped with detection on all three poles.

Indicators

The green "Ready" LED blinks slowly when the electronic trip unit is ready to provide protection. It indicates the trip unit is operating correctly.

Note: all the trip units have a transparent sealable cover that protects access to the adjustment rotary switches.

Micrologic 1.3 M			
Ratings (A)	In at 40 °C ⁽¹⁾	400	600
Circuit breaker	PowerPact L-frame	■	■
S Short time protection			
Pick-up (A) accuracy ±15 %	I_{sd} There is a very short delay to let through motor starting currents	adjustable directly in amps 9 settings: 2000, 2400, 2800, 3200, 3600, 4000, 4400, 4800 A	
Time delay (ms)	I_i	non-adjustable	
	Non-tripping time	20	
	Maximum break time	60	
I Instantaneous protection			
Pick-up (A) accuracy ±15 %	I_i non-adjustable	4800	7200
	Non-tripping time	0	
	Maximum break time	30 ms	

⁽¹⁾ Motor standards require operation at 40 °C. Circuit breaker rating are derated to take this requirement into account.

Micrologic 2.2 M and 2.3 M Electronic trip units

Micrologic 2.2 M and 2.3 M trip units provide built-in thermal and instantaneous protection. They are used in 2-device motor-feeder solutions on PowerPact H-, J- and L-frame circuit breakers with performance levels J/L.

They provide protection for motors up to 315 kW at 400 V against:

- short-circuits
- overloads with selection of a trip class (5, 10 or 20)
- phase unbalance.

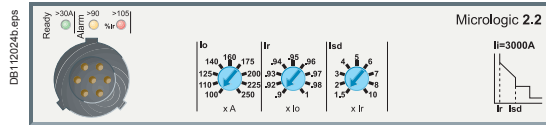

Circuit breakers with Micrologic 2.2M/2.3 M trip unit include protection similar to an inverse-time overload relay. They are combined with a contactor. Protection settings are made using a rotary switch.

Overloads (or thermal protection)

Long-time protection and trip class (FLA).

- Inverse-time thermal protection.
- Against overloads with adjustable pick-up FLA.
- Settings are made in amperes. The tripping curve for the long-time protection, which indicates the time delay t_r before tripping, is defined by the selected trip class.

Trip class

The class is selected as a function of the normal motor starting time:

- class 5: starting time less than 5 s
- class 10: starting time less than 10 s
- class 20: starting time less than 20 s.

For a given class, it is necessary to check that all motor-feeder components are sized to carry the 6 x FLA starting current without excessive temperature rise during the time corresponding to the class.

Short-circuits

- Short-time protection (I_{sd}):
 - provides protection with an adjustable pick-up I_{sd} .
 - there is a very short delay to let through motor starting currents.
- Non-adjustable instantaneous protection (I_i):
 - instantaneous protection with non-adjustable pick-up (I_i).

Phase unbalance or phase loss (I_{unbal})

This function opens the circuit breaker if a phase unbalance occurs:

- that is greater than the 30 % fixed pick-up I_{unbal}
- following the non-adjustable time delay t_{unbal} equal to:
 - 0.7 s during starting
 - 4 s during normal operation.

Phase loss is an extreme case of phase unbalance and leads to tripping under the same conditions.

Indicators

Front indicators

- The green "Ready" LED blinks slowly when the electronic trip unit is ready to provide protection. It indicates the trip unit is operating correctly.
- Red alarm LED for motor operation goes ON when the thermal image of the rotor and stator is greater than 95 % if the permissible temperature rise.

Remote indicators using SDTAM module

PowerPact H-, J- and L-frame devices with a Micrologic 2 M trip unit can be equipped with an SDTAM module dedicated to motor applications for:

- a contact to indicate circuit breaker overload
- a contact to open the contactor. In the event of a phase unbalance or overload, this output is activated 400 ms before circuit breaker tripping to open the contactor and avoid circuit breaker tripping.

This module takes the place of the shunt trip (MN)/undervoltage trip (MX) coils and an auxiliary switch (OF) contact.

SDTAM remote indication relay module with its terminal block.

Note: all the trip units have a transparent sealable cover that protects access to the adjustment rotary switches.

H-frame (150 A), J-frame (250 A) and L-frame (600 A) Electronic motor protector circuit breakers (UI ratings) - Two device solutions ⁽¹⁾						
Electronic trip unit type	Frame	Sensor rating	Trip unit	Full load amperes range (FLA)	I_{sd} (x FLA)	J interrupting cat. no. ⁽¹⁾
Standard ⁽²⁾	H-frame	150	2.2 M	58-130	5-13 x FLA	NHJL36150M38X
	J-frame	250		114-217	5-13 x FLA	NJJL36250M38X
	L-frame	400	2.3 M	190-348	5-13 x FLA	NLJL36400M38X
				312-520	5-13 x FLA	NLJL36600M38X

⁽¹⁾ Two-device solutions (these electronic motor protector circuit breakers include short-circuit and overload protection):

- 1 electronic motor circuit protector with a Micrologic 2.2 M electronic trip unit, plus,
- 1 contactor

⁽²⁾ The standard trip unit offers Class 5, 10 and 20 and phase unbalance or phase loss protection.

⁽³⁾ For references with metric terminals nuts

Micrologic 3 trip units can be used on PowerPact Multistandard circuit breakers with performance levels D/G/J/L.

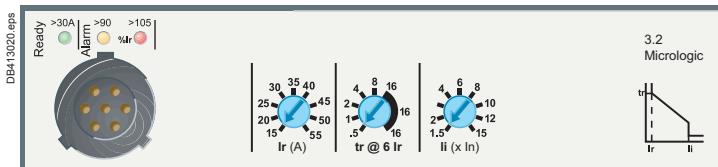

They provide:

- standard protection of distribution cables
- indication of:
 - overloads (using LEDs)
 - overload tripping (using the SDx relay module).

Circuit breakers equipped with Micrologic 3 trip units can be used to protect distribution systems supplied by transformers.

Protection

- Settings are made using the adjustment rotary switches.
- Overloads: Long time protection (I_r)
- Inverse time protection against overloads with an adjustable current pick-up I_r set using a rotary switch and an adjustable time delay t_r .

Indicators

Front indicators

- The green “Ready” LED blinks slowly when the electronic trip unit is ready to provide protection. It indicates the trip unit is operating correctly.
- Orange overload pre-alarm LED: steady on when $I > 90\% I_r$.
- Red overload LED: steady on when $I > 105\% I_r$.



Remote indicators

An overload trip signal can be remotely checked by installing an SDx relay module inside the circuit breaker. This module receives the signal from the Micrologic electronic trip unit through an optical link and makes it available on the terminal block. The signal is cleared when the circuit breaker is reclosed.

See [page A-44](#).

PB103377.eps



Micrologic 3							
Ratings (A)	In at 40 °C (104°F) ⁽¹⁾	60	100	150	250	400	600
Circuit breaker	H-frame	■	■	■	-	-	-
	J-frame	-	-	-	■	-	-
	L-frame	-	-	-	■	■	■

Micrologic 3.2 / 3.3

L Long-time protection

Pick-Up (A) tripping between 1.05 and 1.20 I _r	I _r	Value depending on sensor rating (I _n) and setting on rotary switch									
	I _n = 60 A	I _r =	15	20	25	30	35	40	45	50	60
	I _n = 100 A	I _r =	35	40	45	50	60	70	80	90	100
	I _n = 150 A	I _r =	50	60	70	80	90	100	110	125	150
	I _n = 250 A	I _r =	70	80	100	125	150	175	200	225	250
	I _n = 400 A	I _r =	125	150	175	200	225	250	300	350	400
Time delay (s) accuracy 0 to -20 %	I _n = 600 A	I _r =	200	225	250	300	350	400	450	500	600
	tr		0.5	1	2	4	8	16			
	1.5 x I _r		15	25	50	100	200	400			
	6 x I _r		0.5	1	2	4	8	16			
	7.2 x I _r		0.35	0.7	1.4	2.8	5.5	11			

Thermal memory 20 minutes before and after tripping

I Instantaneous

Pick-up (A) accuracy ±15 %	I _i x I _n	1.5	2	3	4	6	8	10	12	15
	Non-tripping time	10 ms								
	Maximum break time	50 ms for I > 1.5 I _i								

⁽¹⁾ If the trip units are used in high-temperature environments, the Micrologic trip unit setting must take into account the thermal limitations of the circuit breaker. See the temperature derating information on [page B-7](#).

On a fault trip, the type of fault (I_r , I_{sd} , I_i , I_g), the phase concerned and the interrupted current are displayed. An external power supply is required.

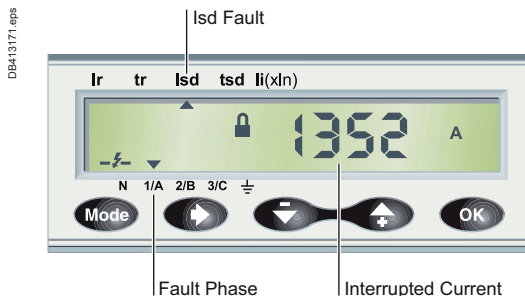

Display of interrupted current.

Indicators

Front Indicators



- The green "Ready" LED blinks slowly when the electronic trip unit is ready to provide protection. It indicates the trip unit is operating correctly.
- Orange overload pre-alarm LED stays on when $I > 90\%$ I_r .
- Red overload LED stays on when $I > 105\%$ I_r .

Remote Indicators

An SDx relay module installed inside the circuit breaker can be used to remote the following information:

- overload trip
- overload prealarm.

This module receives the signal from the Micrologic electronic trip unit through an optical link and makes it available on the terminal block. The signal is cleared when the circuit breaker is closed.

These outputs can be reprogrammed to be assigned to other types of tripping or that protects access to the adjustment rotary switch. The module is described in detail in the section dealing with accessories.

Note: all the trip units have a transparent lead-sealable cover.



Micrologic 5 trip unit

Ratings (A)	In at 40 °C (104°F) ⁽¹⁾	60	100	150	250	400	600										
Circuit breaker	H-frame	■	■	■	-	-	-										
	J-frame	-	-	-	■	-	-										
	L-frame	-	-	-	-	■	■										
L Long-time protection																	
Pick-up (A) tripping between 1.05 and 1.20 I _r	I _r	rotary switch	Value depending on the trip unit rating (I _n) and setting on rotary switch														
	I _n = 60 A	I _r =	15	20	25	30	35	40	45	50	60						
	I _n = 100 A	I _r =	35	40	45	50	60	70	80	90	100						
	I _n = 150 A	I _r =	50	60	70	80	90	100	110	125	150						
	I _n = 250 A	I _r =	70	80	100	125	150	175	200	225	250						
	I _n = 400 A	I _r =	125	150	175	225	225	250	300	350	400						
Time delay (s) accuracy 0 to -20 %	t _r =	keypad setting	Fine adjustment in 1 A steps below maximum value set on rotary switch														
		keypad setting	0.5	1	2	4	8	16									
		1.5 x I _r	15	25	50	100	200	400									
		6 x I _r	0.5	1	2	4	8	16									
		7.2 x I _r	0.35	0.7	1.4	2.8	5.5	11									
Thermal memory	20 minutes before and after tripping																
S Short-time protection																	
Pick-up (A) accuracy ±10 %	I _{sd}	keypad setting	1.5	2	2.5	3	3.5	4	4.5	5	5.5	6	6.5	7	7.5	8.5	9.5
			Fine adjustment in 0.5 x I _r steps using the keypad														
Time delay (s)	tsd =	keypad setting	I _{sd} Off	0	0.1	0.2	0.3	0.4									
			I _{sd} On	-	0.1	0.2	0.3	0.4									
		Non-tripping time	20	80	140	230	350										
Maximum break time	80	140	200	320	500												
I Instantaneous																	
Pick-up (A) accuracy ±15 %	I _i = I _n x	rotary switch	60 A	1.5	2	.3	4	6	8	10	12	15					
			100 A	1.5	2	.3	4	6	8	10	12	15					
			150 A	1.5	2	.3	4	6	8	10	12	15					
			250 A	1.5	2	.3	4	5	6	8	10	12					
			400 A	1.5	2	.3	4	5	6	8	10	12					
			600 A	1.5	2	.3	4	5	6	8	10	11					
Non-tripping time	10 ms																
Maximum break time	50 ms for I > I _i																

(1) If the trip units are used in high-temperature environments, the Micrologic trip unit setting must take into account the thermal limitations of the circuit breaker.

Micrologic 5 E (Energy) trip units can be used on PowerPact Multistandard circuit breakers with performance levels D, G, J. They all have a front display module. They offer basic LSI protection (Micrologic 5 trip unit). They also offer measurement, alarm and energy values.

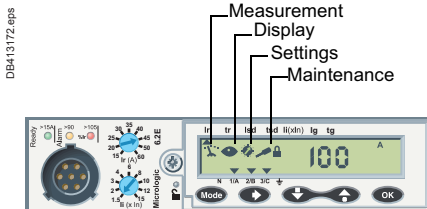

The capabilities of Micrologic 5 E trip units come into full play with the front display module. When the two are connected using a simple cable with RJ45 connectors, the combination offers full Power Meter capabilities and all the measurements required to monitor the electrical installation.

Measurements

Current measurements

- Phase and neutral currents I_A , I_B , I_C , I_N .
- Average current of the 3 phases I_{avg} .
- Highest current of the three phases I_{max} .
- Maximum and minimum current measured.
- Current unbalance between phases.

Voltage measurements

- Phase-to-phase (V) and phase-to-neutral (U) voltages.
- Average voltages V_{avg} , U_{avg} .
- Ph-Ph (V) and Ph-N (U) voltage unbalance.
- Frequency measurements.
- Frequency (f).

Power-quality indicators

- Total harmonic distortion (THD) for current and voltage

Power measurements

- Active, reactive and apparent power, total and per phase.
- Power factor and $\cos \varphi$.
- Maximum and minimum.
- For all I, V, f, P, E measurements.

Demand current and power measurements

- Demand values, total and per phase.
- Maximum demand.
- Energy metering.
- Active, reactive and apparent energy, total and per phase.

Operating and maintenance assistance

Indicators, alarms and histories

- Fault types.
- Alarms for high/low thresholds linked to I, V, f, P, E measurements.
- Trip, alarm and operating histories.
- Time-stamped tables for settings and I, V, f, P, E maximum values.

Maintenance indicators

- Operation, trip and alarm counters.
- Operating hours counter.
- Contact wear.
- Load profile and thermal image.

Communication network

Modbus with add-on module

Protection

- Settings can be adjusted in two ways, using the rotary switches and/or the keypad.
- The keypad can be used to make fine adjustments in 1 A steps below the maximum value defined by the setting on the rotary switch.
- Access to setting modifications using the keypad is protected by a locking function displayed on the screen and controlled by a microswitch.
- The lock is activated automatically if the keypad is not used for 5 minutes.
- Access to the microswitch is protected by a transparent, sealable cover.
- With the cover closed, it is still possible to display the various settings and measurements using the keypad.

Overloads: long-time protection (I_r)

Inverse time protection against overloads with an adjustable current pick-up I_r is set using a rotary switch or the keypad for fine adjustments. The time delay t_r is set using the keypad.

Short-circuits: short-time protection (I_{sd})

Short-circuit protection with an adjustable pick-up I_{sd} and adjustable time delay t_{sd} , with the possibility of including a portion of an inverse time curve (I^2t On).

Short-circuits: instantaneous protection (I_i)

Instantaneous protection with adjustable pick-up I_i .

PB113887.eps



PB113886.eps



Automatic Molded Case Switches (Functions/Protection)

An automatic switch can be used to open and close a circuit under normal operating conditions. They are similar in construction to circuit breakers, except that the switches open instantaneously at a factory-set, non-adjustable trip point calibrated to protect only the molded case switch.

Molded case switches are intended for use as disconnect devices only. UL489 requires molded case switches to be protected by a circuit breaker or fuse of equivalent rating. Molded case switches are labeled with their appropriate withstand ratings.

The withstand rating of a switch is defined as the maximum current at rated voltage that the molded case switch will withstand without damage when protected by a circuit breaker with an equal continuous current rating. PowerPact™ H-, J-, and L-frame automatic switches are available in unit mount, I-Line™, plug-in and drawout versions.

They use the same accessories and offer the same connection possibilities as the circuit-breaker versions. They may be interlocked with another switch or circuit breaker to form a source-changeover system. Switches are Listed under UL file E103740 and Certified under CSA file LR88980.

Automatic Switch Protection

The automatic switch can make and break its rated current. For an overload or a short-circuit, it must be protected by an upstream device, in compliance with installation standards. Due to their high-set instantaneous release PowerPact H-, J- and L-frame automatic switches are self-protected.

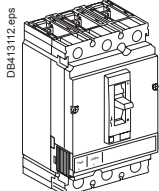
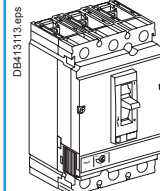
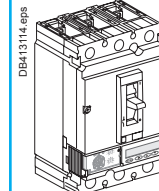
Frame		H-Frame	J-Frame	L-Frame ⁽¹⁾	
Withstand rating		"L"	"L"	"L"	
Ampere rating (A)		150	250	400	600
					
UL489	Poles	3P	3P	3P	3P
	Catalogue number	NHLL36000S15	NJLL36000S25	NLLL36000S40X	NLLL36000S60X
	Withstand ratings	240 V AC	125 kA	125 kA	125 kA
		480 V AC	100 kA	100kA	100kA
		600 V AC	50 kA	50 kA	50 kA
		250 V DC	20 kA	20kA	-
	AC trip point	2250 A	3125 A	4800 A	6600 A
	Rated voltage (AC)	-	-	600	600
IEC 60947-3	Rated insulation voltage (V AC)	750	750	750	750
	Rated impulse withstand voltage (kV)	8	8	8	8
	Rated operational voltage	AC	690	525	690
		DC	-	500	-
	Rated operational current (Ie) AC 525 V			400	600
	Making capacity (kA peak)			7.1	8.5
	Short-time withstand current (kA rms)	Icw (kA rms)		5	6
		Duration(s)			1

⁽¹⁾ Standard lug terminal wire range: AL66LS52K3; 2 AWG-500 kcmil Al/Cu.

In addition to protection functions, Micrologic A/E trip units offer all the functions of Power Meter products as well as operating assistance for the circuit breaker.

Micrologic A/E trip unit measurement functions are made possible by the Micrologic trip unit's intelligence and the accuracy of the sensors. They are handled by a microprocessor that operates independent of protection functions.

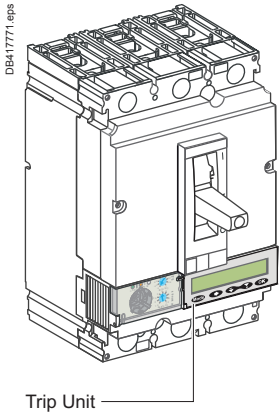

Display functions

Micrologic Trip Unit LCD

The user can display all the protection settings and the main measurements on the LCD screen of the trip unit.

- Micrologic A trip unit: instantaneous rms current measurements
 - Micrologic E trip unit: voltage, frequency and power measurements and energy metering, in addition to the measurements offered by Micrologic A.
- To make the display available under all conditions and increase operating comfort, an external power supply is recommended for Micrologic A trip unit. It is required to:
- display faults and interrupted current measurements
 - use all the functions of Micrologic E trip unit (such as metering of low power and energy values)
 - ensure operation of the communication network.

The external power supply can be shared by several devices. For description, see [page A-29](#).

FDM121 Display Unit (One to One)

The FDM121 switchboard display unit can be connected to a communication (COM) option (Breaker Communication Module [BSCM]) using a circuit breaker ULP cord to display all measurements on a screen. The LCD screen is 3.78 x 3.78 in. (96 x 96 mm). The FMD121 display unit requires a 24 Vdc power supply. The COM option (BSCM) unit is supplied by the same power supply via the circuit breaker ULP cord connecting it to the FDM121. See [page A-24](#) for more information.

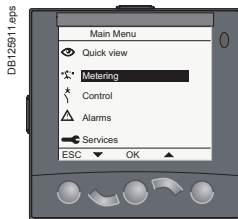

FDM121 Display: Navigation

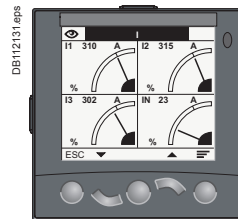

FDM121 Display: Current

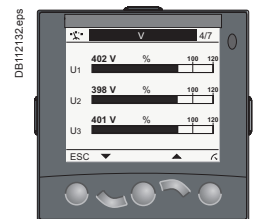

FDM121 Display: Voltage

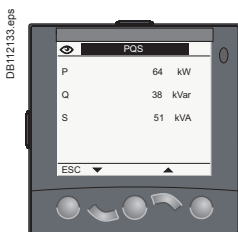

FDM121 Display: Power

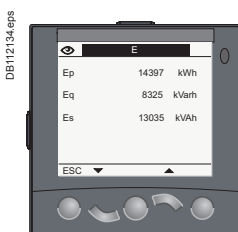

FDM121 Display: Consumption

FDM128 Display Unit (One to Eight)

The FDM128 display unit uses an IFE Ethernet interface for low-voltage circuit breakers.

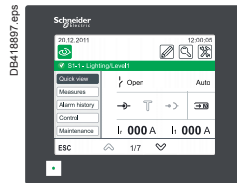

FDM128 Display:
Navigation

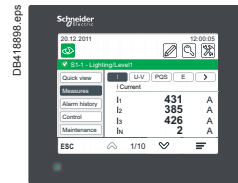

FDM128 Display:
Current

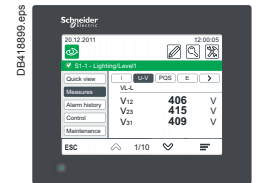

FDM128 Display:
Voltage

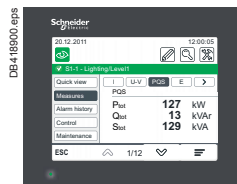

FDM128 Display:
Power

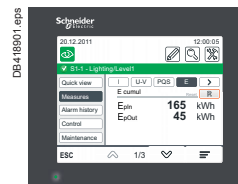

FDM128 Display:
Consumption

For all FDM, in addition to the information displayed on the Micrologic trip unit LCD, the FDM screen shows demand, power quality, and maximum/minimum ammeter values along with histories and maintenance indicators.

Measurements function

Instantaneous RMS measurements

The Micrologic trip unit continuously displays the RMS value of the highest current of the three phases and neutral (Imax). The navigation buttons can be used to scroll through the main measurements.

In the event of a fault trip, the trip cause is displayed.

The Micrologic A trip unit measures phase, neutral, and ground fault currents.

Micrologic E trip units offer voltage, power, frequency, and energy metering in addition to the measurements provided by Micrologic A trip units.

Maximum / Minimum ammeter

Every instantaneous measurement provided by Micrologic A/E trip units can be associated with a maximum/minimum ammeter. The maximum for the highest current of the three phases, neutral, and demand current can be reset using the Micrologic trip unit keypad, FDM display unit, or the communication system.

Energy metering

The Micrologic E trip units also measures the energy consumed since the last reset of the meter. The active energy meter can be reset using the Micrologic trip unit keypad, the FDM display unit, or the communication system.

Demand and maximum demand values

Micrologic E trip units also calculate demand current and power values. These calculations can be made using a block or sliding interval that can be set from five to sixty minutes in steps of one minute. The window can be synchronised with a signal sent through the communication system. Whatever the calculation method, the calculated values can be recovered on a PC through the communication network. Ordinary spreadsheet software can be used to provide trend curves and forecasts based on this data. They provide a basis for load shedding and reconnection operations used to adjust consumption to the subscribed power.

Power quality

The Micrologic E trip unit calculates power quality indicators taking into account the presence of harmonics up to the fifteenth harmonic, including the total harmonic distortion (THD) of current and voltage.



Micrologic 5 trip unit integrated Power Meter functions				Type		Display	
				A	E	Trip Unit LCD	Front Display Module
Display of protection settings							
Pick-ups (A) and delays	All settings can be displayed	I _r , t _r , I _{sd} , t _{sd} , I _i , I _g , t _g	■	■	■		
Measurements							
Instantaneous rms measurements							
Currents (A)	Phase and neutral	I _A , I _B , I _C , I _N	■	■	■		■
	Average of phases	I _{avg} = (I _A + I _B + I _C) / 3	■	■	-		■
	Highest current of the 3 phases and neutral	I _{max} of I _A , I _B , I _C , I _N	■	■	■		■
	Ground fault	% I _g (pick-up setting)	■	■	■		■
	Current unbalance between phases	% I _{avg}	-	■	-		■
Voltage (V)	Phase-to-phase	V _{AB} , V _{BC} , V _{CA}	-	■	■		■
	Phase-to-neutral	U _{AN} , U _{BN} , U _{CN}	-	■	■		■
	Average of phase-to-phase voltages	V _{avg} = (V _{AB} + V _{BC} + V _{CA}) / 3	-	■	-		■
	Average of phase-to-neutral voltages	U _{avg} = (U _{AN} + U _{BN} + U _{CN}) / 3	-	■	-		■
	Ph-Ph and Ph-N voltage unbalance	% V _{avg} and % U _{avg}	-	■	-		■
	Phase sequence	1-2-3, 1-3-2	-	■	■		■ ⁽³⁾
Frequency (Hz)	Power system	f	-	■	■		■
Power	Active (kW)	P, total/per phase	-	■	■		■
	Reactive (kVAR)	Q, total/per phase	-	■	■		■
	Apparent (kVA)	S, total/per phase	-	■	■		■
	Power factor and cos φ (fundamental)	PF and cos φ, total and per phase	-	■	-		■
Maximum, minimum (MAX/MIN)							
	Associated with instantaneous rms measurements	Reset with Micrologic trip unit or front display module	■	■	-		■
Energy metering							
Energy	Active (kWh), reactive (kVAR), apparent (kVA)	Total since last reset Absolute or signed mode ⁽¹⁾	-	■	■		■
Demand and maximum demand values							
Demand current (A)	Phases and neutral	Present value on the selected window	-	■	-		■
		Maximum demand since last reset	-	■	-		■
Demand power	Active (kWh), reactive (kVAR), apparent (kVA)	Present value on the selected window	-	■	-		■
		Maximum demand since last reset	-	■	-		■
Calculation window		Adjustable from 5 to 60 minutes in 1 minute steps	-	■	-		■ ⁽²⁾
Power quality							
Total harmonic distortion THD (%)	Of voltage with respect to rms value	THDU, THDV of the Ph-Ph and Ph-N voltage	-	■	-		■
	Of current with respect to rms value	THDI of the phase current	-	■	-		■

(1) Absolute mode: $E_{absolute} = E_{out} + E_{in}$; Signed mode: $E_{signed} = E_{out} - E_{in}$.

(2) Available through the communication network only.

Additional technical characteristics

Measurement accuracy of the entire measurement system, including the sensors:

- Current: ±1 %.
- Voltage: ±0.5 %.
- Power and energy: ±2 %.
- Frequency: ±0.1 %.

Operating-assistance functions characteristics

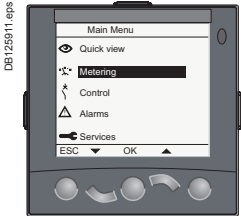

FDM121 display: navigation.

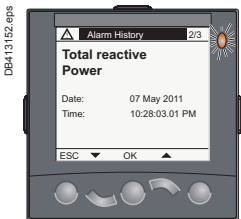

Over power alarm.

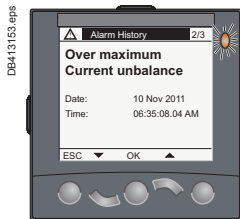

Phase unbalance alarm.



Alarm pick-up and drop-out examples of operating-assistance screens of the FDM121 display unit.

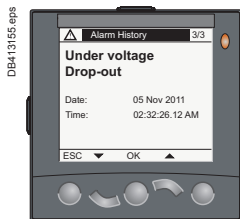

Micrologic trip unit alarms with time-stamping

Alarm types

The user can assign an alarm to all Micrologic A or E trip unit measurements or events:

- up to 12 alarms can be used together:
- one alarm is predefined and activated automatically:
Micrologic 5 trip unit: overload (Ir)
- thresholds, priorities and time delays can be set for ten other alarms.
- the same measurement can be used for different alarms to precisely monitor certain values, e.g. the frequency or the voltage
- alarms can also be assigned to various states: phase lead/lag, four quadrants, phase sequence
- selection of display priorities, with screen displaying a window showing high priority alarm
- alarm time-stamping.

Alarm settings

Alarms cannot be set using the keypad or the front display module. They are set through the communication network with the PC. Set-up includes the threshold, priority, activation delay before display and deactivation delay. It is also possible to reprogram the standard assignment for the two SDx relay outputs to user-selected alarms.

Alarm reading

Remote alarm indicators:

- reading on the front display module or on a PC through the communication network
- system remote indicators using SDx relay with two output contacts for alarms
- Micrologic trip unit built-in LCD display.

Histories and event tables

Micrologic A and E trip unit have histories and event tables that are always active.

Three types of time-stamped histories

- Tripping due to overruns of Ir, I_{sd}, I_l, I_g: last 17 trips
- Alarms: last 10 alarms
- Operating events: last 10 events.

Each history record is stored with:

- indicators in clear text in a number of user-selectable languages
- time-stamping: date and time of event
- status: pick-up / drop-out.

Two types of time-stamped event tables

- Protection settings
- Minimums / maximums

Display of alarms and tables

The time-stamped history and event tables may be displayed on a PC through the communication network.

Embedded memory

Micrologic A and E trip units have a non-volatile memory that saves all data on alarms, histories, event tables, counters and maintenance indicators even if power is lost.

Maintenance indicators

Micrologic A and E trip units have indicators for, among others, the number of operating cycles, contact wear and operating times (operating hours counter) of the PowerPact H-, J-, and L-frame circuit breakers.

It is possible to assign an alarm to the operating cycle counter to plan maintenance. The various indicators can be used together with the trip histories to analyze the level of stresses the device has been subjected to. The information provided by the indicators cannot be displayed on the Micrologic trip unit LCD. It is displayed on the PC through the communication network.

Management of installed devices

Each circuit breaker equipped with a Micrologic 5 trip unit can be identified using the communication network:

- serial number
- firmware version
- hardware version
- device name assigned by the user.

This information together with that previously described provides a clear view of the state of the installed devices.

Note: please refer to page A-21 for more details on display formats.



Micrologic 5 trip unit operating assistance functions			Type		Display	
			A	E	Trip Unit LCD	Front Display Module
Operating Assistance						
Personalized alarms						
Settings	Up to 10 alarms assigned to all A and E measurements			■		(1)
	Phase lead/lag, four quadrants, phase sequence, display priority selection			-	■	(1)
Display	Alarms and tripping			■	■	(1)
Remote indicators	Activation of two dedicated contacts on SDx module			■	■	(1)
Time-stamped histories						
Trips (last 17)	Cause of tripping (time-stamping with ms)	Ir, lsd, li		■	■	(1)
Alarms (last 10)				■	■	(1)
Operating events (last 10)	Event types	Modification of protection setting by rotary switch		-	■	(1)
		Opening of keypad lock		-	■	(1)
		Test using keypad		-	■	(1)
		Test using external tool		-	■	(1)
		Time setting (date and time)		-	■	(1)
	Reset for maximum, minimum and energy meter			■	■	■
Time stamping	Presentation	Date and time, text, status		■	■	(1)
Time-stamped event tables						
Protection settings	Setting modified (value displayed)	Ir tr lsd tsd li lg tg		■	■	(1)
	Time-stamping	Date and time of modification		■	■	(1)
	Previous value	Value before modification		■	■	(1)
Min/Max	Values monitored	IA IB IC IN li		■	■	(1)
	Time-stamping	Date and time of min/max record		■	■	(1)
	Previous value	Min/max value				
Maintenance indicators						
Counter	Mechanical cycles ⁽²⁾	Assignable to an alarm		■	■	(1)
	Electrical cycles ⁽²⁾	Assignable to an alarm				
	Trips	One per type of trip				
	Alarms	One for each type of alarm				
	Hours	Total operating time (hours)				
Indicator	Contact wear	%		■	■	(1)
Load profile	Hours at different load levels	% of hours in four current ranges: 0 - 49 % In, 50 - 79 % In, 80 - 89 % In and ≥ 90 % In		■	■	(1)

(1) Available through the communication network only.
 (2) The BSCM (page A-29) is required for these functions.

PowerPact H-, J-, and L-frame circuit breakers

Energy Management

Additional technical characteristics

Contact wear

Each time PowerPact H-, J-, and L-frame circuit breakers open, the Micrologic 5 trip unit measures the interrupted current and increments the contact-wear indicator as a function of the interrupted current, according to test results stored in memory. Breaking under normal load conditions results in a very slight increment. The indicator value may be read on the front display module. It provides an estimation of contact wear calculated on the basis of the cumulative forces affecting the circuit breaker. When the indicator reaches 80 %, it is advised to replace the circuit breaker to ensure the availability of the protected equipment.

Circuit breaker load profile

Micrologic 5 trip unit calculate the load profile of the circuit breaker protecting a load circuit. The profile indicates the percentage of the total operating time at four current levels (% of I_n):

- 0 to 49 % I_n
- 50 to 79 % I_n
- 80 to 89 % I_n
- u 90 % I_n .

This information can be used to optimize use of the protected devices or to plan ahead for expansion.

Switchboard-display functions

Micrologic E trip unit with COM option (ULP)

Micrologic trip unit measurement capabilities come into full play with the FDM121 display. It connects with a circuit breaker ULP cord and displays the Micrologic trip unit information. The result is a true integrated unit combining a circuit breaker and a power meter. Additional operating assistance functions can also be displayed.

FDM121 switchboard display

An FDM121 display unit can be connected to ULP communication devices using a prefabricated cord to display all measurements, alarms, histories and event tables, maintenance indicators, and management of installed devices on a screen.

The FDM121 display unit requires a 24 V DC power supply.

The FDM121 is a display that can be integrated with the PowerPact H/J/L/P/R or Masterpact NW/NT circuit breaker systems. It uses the sensors and processing capacity of the Micrologic trip unit. It is easy to use and requires no special software or settings. It is immediately operational when connected to the circuit breaker by a ULP cord.

It also provides monitoring and control with the use of the I/O application module, the motor mechanism module, or the circuit breaker communication module.

The FDM121 has a large display, but requires very little depth. The anti-glare graphic screen is backlit for very easy reading even under poor ambient lighting and at sharp angles.

Display of Micrologic trip unit measurements and alarms

The FDM121 is intended to display Micrologic trip unit measurements, alarms and operating information. It cannot be used to modify the protection settings.

Measurements can be easily accessed using a menu. All user-defined alarms are automatically displayed. The display mode depends on the priority level selected during alarm set-up:

- high priority: a pop-up window displays the time-stamped description of the alarm and the orange alarm LED flashes
- medium priority: the orange Alarm LED goes continuously on
- low priority: no display on the screen.

All faults resulting in a trip automatically produce a high-priority alarm, without any special settings required. In all cases, the alarm history is updated. The Micrologic trip unit saves the information in its non-volatile memory in the event of an FDM121 power loss.

Status indications and remote control

When the circuit breaker is equipped with the Breaker Communications Module (BSCM), the FDM121 display can also be used to view circuit breaker status conditions:

- O/F: ON/OFF
- SD: trip indication
- SDE: fault-trip indication (overload, short-circuit, ground fault).

When the circuit breaker system is equipped with the I/O application module, the FDM121 can monitor and control:

- cradle management
- circuit breaker operation
- light and load control
- custom applications.

When the circuit breaker is equipped with the communication motor operator etc., the FDM121 display can also be used to control (open/close) the circuit breaker.

Two operating mode are available:

- local mode: open/close commands are enabled from the FDM121 while disabled from the communication network
- remote mode: open/close commands are disabled from the FDM121 while enabled from the communication network.

Main characteristics

- A 3.78 x 3.78 x 1.18 in. (96 x 96 x 30 mm) screen requiring 0.39 in. (10 mm) behind the door (or 0.79 in. [20 mm] when the 24 V power supply connector is used)
 - White backlighting
 - Wide viewing angle: vertical $\pm 60^\circ$, horizontal $\pm 30^\circ$
 - High resolution: excellent reading of graphic symbols
 - Alarm LED: flashing orange for alarm pick-up, steady orange after operator reset if the alarm condition persists.
 - Operating temperature range: +14 °F (-10 °C) to +131 °F (+55 °C)
 - CE / UL / CSA marking
 - 24 V DC power supply, with tolerances 24 V -20 % (19.2 V) to 24 V +10 % (26.4 V).
- When the FDM121 is connected to the communication network, the 24 V DC can be supplied by the communication system wiring system. Consumption is 40 mA.

Mounting

The FDM121 is easily installed in a switchboard.

- Standard door cut-out is 3.6 x 3.6 in. (92 x 92 mm)
- Attached using clips.

To avoid a cut-out in the door, an accessory is available for surface mounting by drilling only two 0.87 in. (22 mm) diameter holes.

Connection

The FDM121 is equipped with a 24 V DC terminal block:

- A plug-in type terminal block with two wire inputs per point for easy daisy-chaining



FDM121 display.

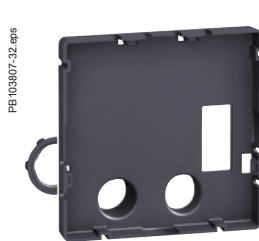

Surface mount accessory.



Connection with FDM121 display unit.

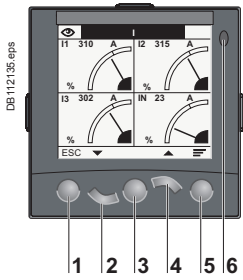

- 1 Escape
- 2 Down
- 3 OK
- 4 Up
- 5 Context
- 6 Alarm LED

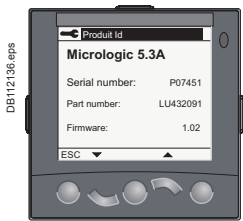

Product identification.

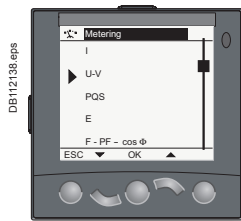

Metering: sub-menu.

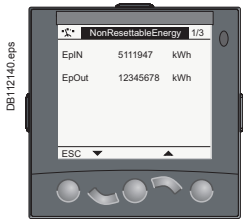

Metering: meter.

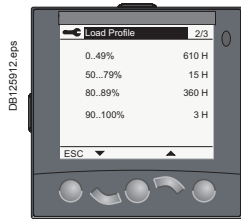

Services.

- A power supply range of 24 V DC -20% (19.2 V) to 24 V DC +10% (26.4 V). A 24 V DC type auxiliary power supply must be connected to a single point on the ULP system. The FDM121 display has a two-point screw connector on the rear panel of the module for this purpose. The ULP module to which the auxiliary power supply is connected distributes the supply via the ULP cable to all the ULP modules connected to the system and therefore also to Micrologic trip unit. See wiring diagram later in this section

- Two RJ45 jacks.

The Micrologic trip unit connects to the internal communication terminal block on the PowerPact or Compact circuit breaker with the circuit breaker ULP cord. Connection to one of the RJ45 connectors on the FDM121 automatically establishes communication between the Micrologic trip unit and the FDM121 and supplies power to the Micrologic trip unit measurement functions.

When the second connector is not used, it must be fitted with a line terminator.

Navigation

Five buttons are used for intuitive and fast navigation.

The "Context" button may be used to select the type of display (digital, bargraph, analogue).

The user can select the display language (Chinese, English, French, German, Italian, Portuguese, Spanish, etc.).

Screens

Main menu

When powered up, the FDM121 screen automatically displays the ON/OFF status of the device.

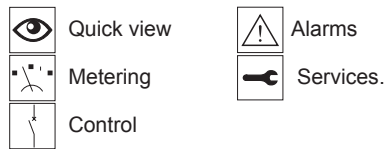

When not in use, the screen is not backlit. Backlighting can be activated by pressing one of the buttons. It goes off after three minutes.

Fast access to essential information

- "Quick view" provides access to five screens that display a summary of essential operating information (I, U-V, f, P, E, THD, circuit breaker ON/OFF).

Access to detailed information

- "Metering" can be used to display the measurement data (I, U-V, f, P, Q, S, E, THD, PF) with the corresponding min/max values

- "Alarms" displays active alarms and the alarm history

- "Services" provides access to the operation counters, energy and maximum ammeter reset function, maintenance indicators, identification of modules connected to the internal bus, and FDM121 internal settings (language, contrast, etc.)

Communication components and FDM121 connections

The FDM121 degree of protection is IP54 in front. IP54 is maintained after switchboard mounting by using the supplied gasket during installation.

FDM121 Connections

Communication components and connections

Communication components and connections, IFM

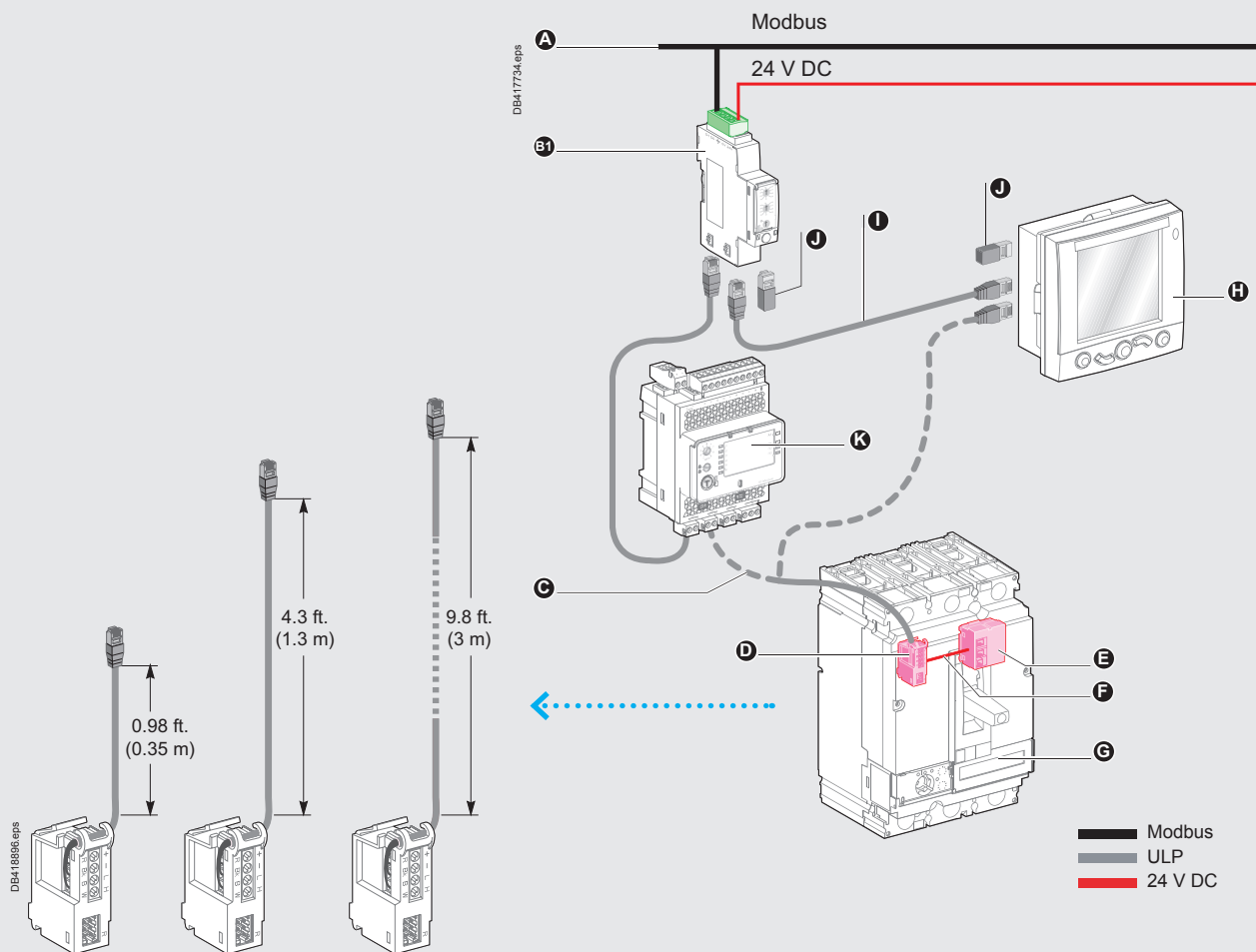

- A** Modbus network
- B** Modbus interface
 - B1** B1: IFM Modbus interface
 - B2** B2: IFE Modbus interface
- C** NSX cord
- D** Internal terminal block for communication via NSX cord
- E** BSCM module
- F** Prefabricated wiring
- G** Micrologic trip unit
- H** FDM121 display
- I** RJ45 cable
- J** Line terminator (on unused connector if applicable)
- K** I/O module

Connections

PowerPact circuit breaker is connected to the I/O module or FDM121 display unit via the internal terminal block for the NSX cord equipped with an RJ45 connector:

- Cord is available in three lengths: 0.98 ft. (0.35 m), 4.3 ft. (1.3 m) and 9.8 ft. (3 m)
- Lengths up to 32.9 ft. (10 m) are possible using extensions.

The FDM121 display unit and the I/O module are connected to:

- the IFM Modbus interface by a communication cable with RJ45 connectors on both ends or
- the IFE Ethernet interface module by a communication cable with RJ45 connectors on both ends.

Communication components and connections, IFE

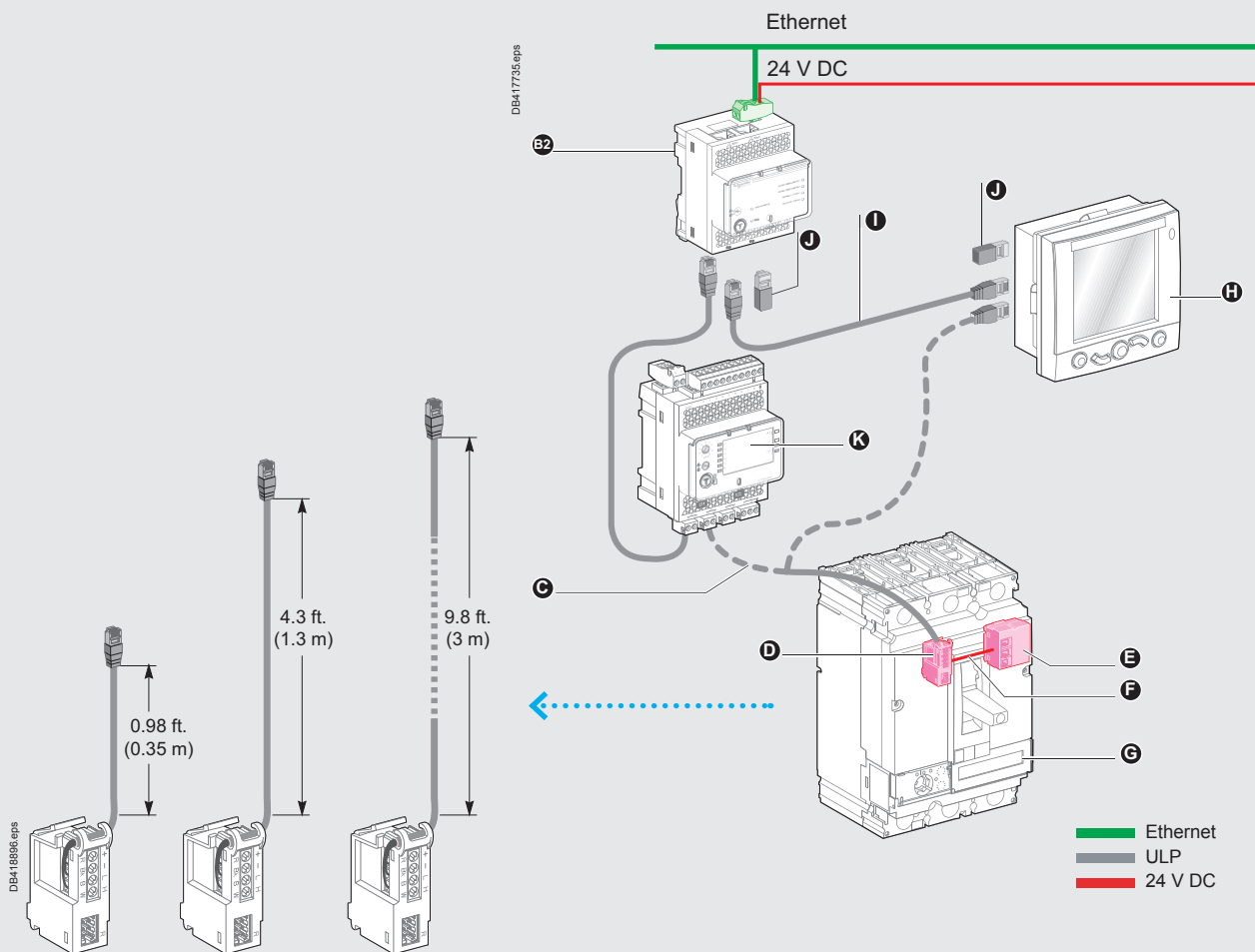

- A** Modbus network
- B** Modbus interface
 - B1** B1: IFM Modbus interface
 - B2** B2: IFE Modbus interface
- C** NSX cord
- D** Internal terminal block for communication via NSX cord
- E** BSCM module
- F** Prefabricated wiring
- G** Micrologic trip unit
- H** FDM121 display
- I** RJ45 cable
- J** Line terminator (on unused connector if applicable)
- K** I/O module

Connections

PowerPact circuit breaker is connected to the I/O module or FDM121 display unit via the internal terminal block for the NSX cord equipped with an RJ45 connector:

- Cord is available in three lengths: 0.98 ft. (0.35 m), 4.3 ft. (1.3 m) and 9.8 ft. (3 m)
- Lengths up to 32.9 ft. (10 m) are possible using extensions.

The FDM121 display unit and the I/O module are connected to:

- the IFM Modbus interface by a communication cable with RJ45 connectors on both ends or
- the IFE Ethernet interface module by a communication cable with RJ45 connectors on both ends.

Switchboard-display functions

Micrologic E trip unit with COM Ethernet gateway

The Micrologic trip unit measurement capabilities are fully utilized with the FDM128 display. The FDM128 display connects to Ethernet communication using the RJ45 port and displays Micrologic trip unit information. The result is an integrated unit combining a circuit breaker with a power meter. Additional operating assistance functions can also be displayed.

FDM128 switchboard display

The FDM128 display unit can be connected to a Micrologic COM option (BSCM). It uses the sensors and processing capacity of the Micrologic trip unit and requires no special software or settings. The FDM128 is a large display, but requires very little depth. The anti-glare graphic screen is backlit for easy reading even under poor ambient lighting and at sharp angles. The FDM128 display is designed to manage up to eight devices (PowerPact H/J/L/P/R or Masterpact NW/NT circuit breakers).

Display of Micrologic trip unit measurements and trips

The FDM128 is intended to display Micrologic 5 trip unit measurements, trips, and operating information. It cannot be used to modify the protection settings.

- Measurements may be easily accessed using a menu
- Trips are automatically displayed
- A pop-up window displays the time-stamped description of the trip.

Status indications

When the circuit breaker is equipped with the COM option (BSCM) (including its set of sensors) the FDM128 display can also be used to view circuit breaker status conditions:

- O/F: ON/OFF
- SDE: Fault-trip indication (overload, short-circuit, ground fault)
- PF: ready to close
- CE, CD, CT cradle management with I/O application module.

Remote control

When the circuit breaker is equipped with the COM option (BSCM) (including connection to a communicating motor operator), the FDM128 display can also be used to operate (open/close) the circuit breaker.

Two operating mode are available:

- local mode: open/close commands are enabled from the FDM128 while disabled from the communication network
- remote mode: open/close commands are disabled from the FDM128 while enabled from the communication network.

Main characteristics

- 4.54 x 3.40 in. (115.2 x 86.4 mm) with 5.7 in. (145 mm) QVGA display 320 x 240 pixels
- Color TFT LCD, with LED backlight.
- Wide viewing angle: vertical $\pm 80^\circ$, horizontal $\pm 70^\circ$.
- High resolution: excellent reading of graphic symbols.
- Operating temperature range: +14 °F (-10 °C) to +131 °F (+55 °C)
- CE / UL / CSA marking
- 24 V DC power supply, -10%/+20% (limit 20.4 - 28.8 V DC)
- Consumption 6.8 W.

Mounting

The FDM128 is easily installed in a switchboard.

- Standard door hole \varnothing 0.87 in. (22 mm)
- The FDM128 degree of protection is IP65 at the touch screen cover. IP54 is maintained after installation by using the supplied gasket.

Connection

The FDM128 is equipped with:

- A 24 V DC terminal block:
 - with a power supply range of 24 V DC (limit 20.4 - 28.8 V DC)
 - secures to the FDM128 display unit using a 2-point screw connector on the rear panel of the module.
- One RJ45 Ethernet jacks.

The Micrologic trip unit connects to the internal communication terminal block on the PowerPact circuit breakers through the circuit breaker ULP cord and Ethernet connection through the IFE.



FDM128 display.

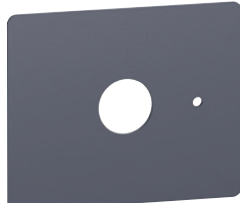

Surface mount accessory.



DB414405.eps



Product identification.

DB414407.eps

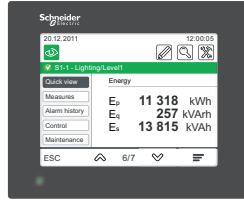

Metering: meter.

DB414408.eps

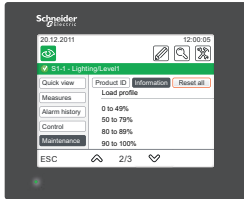

Services.

Navigation

A touch screen is used for intuitive and fast navigation.

The user can select the display language (Chinese, English, French, German, Italian, Portuguese, Spanish, etc.).

Screens

Main menu



Quick view



Alarms



Metering



Maintenance



Control

When not in use, the screen is automatically shifted to low back-lighting.

Fast access to essential information

- "Quick view" provides access to five screens that display a summary of essential operating information (I, U-V, f, P, E, THD, circuit breaker ON / OFF).

Access to detailed information

- "Metering" can be used to display the measurement data (I, U-V, f, P, Q, S, E, THD, PF) with the corresponding min/max values

- "Alarms" displays the trip history

- "Maintenance" provides access to the operation counters, energy and maximum ammeter reset function, maintenance indicators, identification of modules connected to the internal bus and FDM128 internal settings (language, contrast, etc.).

FDM128 Connections

Communication components and connections

Communication components and FDM128 connections

The FDM128 degree of protection is IP65 at the touch screen cover. IP54 is maintained after installation by using the supplied gasket.

Connections

PowerPact circuit breaker is connected to the I/O module or FDM121 display unit via the internal terminal block for the NSX cord equipped with an RJ45 connector:

- Cord is available in three lengths: 0.98 ft. (0.35 m), 4.3 ft. (1.3 m) and 9.8 ft. (3 m)
- Lengths up to 32.9 ft. (10 m) are possible using extensions.

The FDM121 display unit and the I/O module are connected to:

- the IFM Modbus interface by a communication cable with RJ45 connectors on both ends
- or
- the IFE Ethernet interface module by a communication cable with RJ45 connectors on both ends.

Communication components and connections

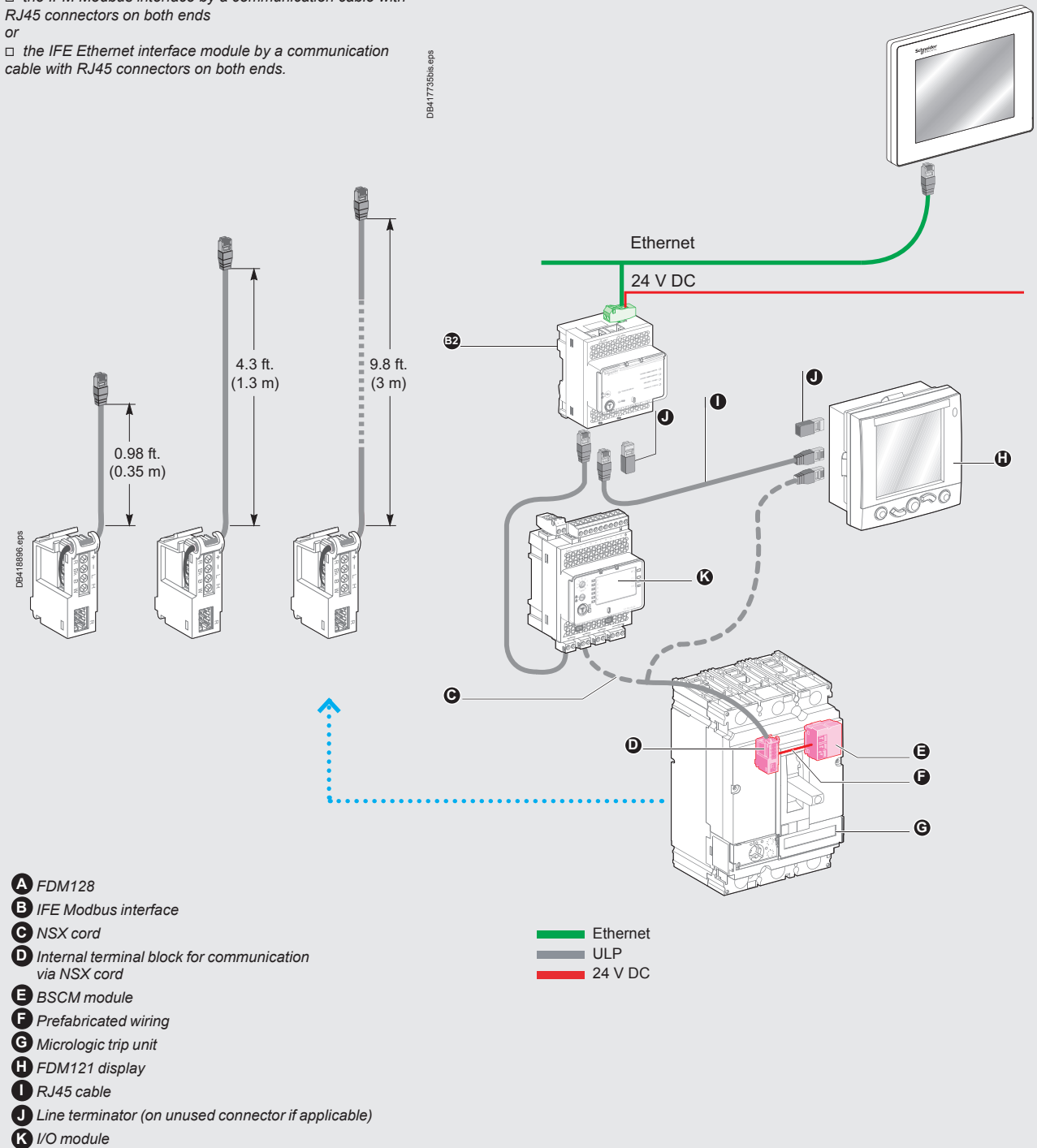

Enerlin'X communication system









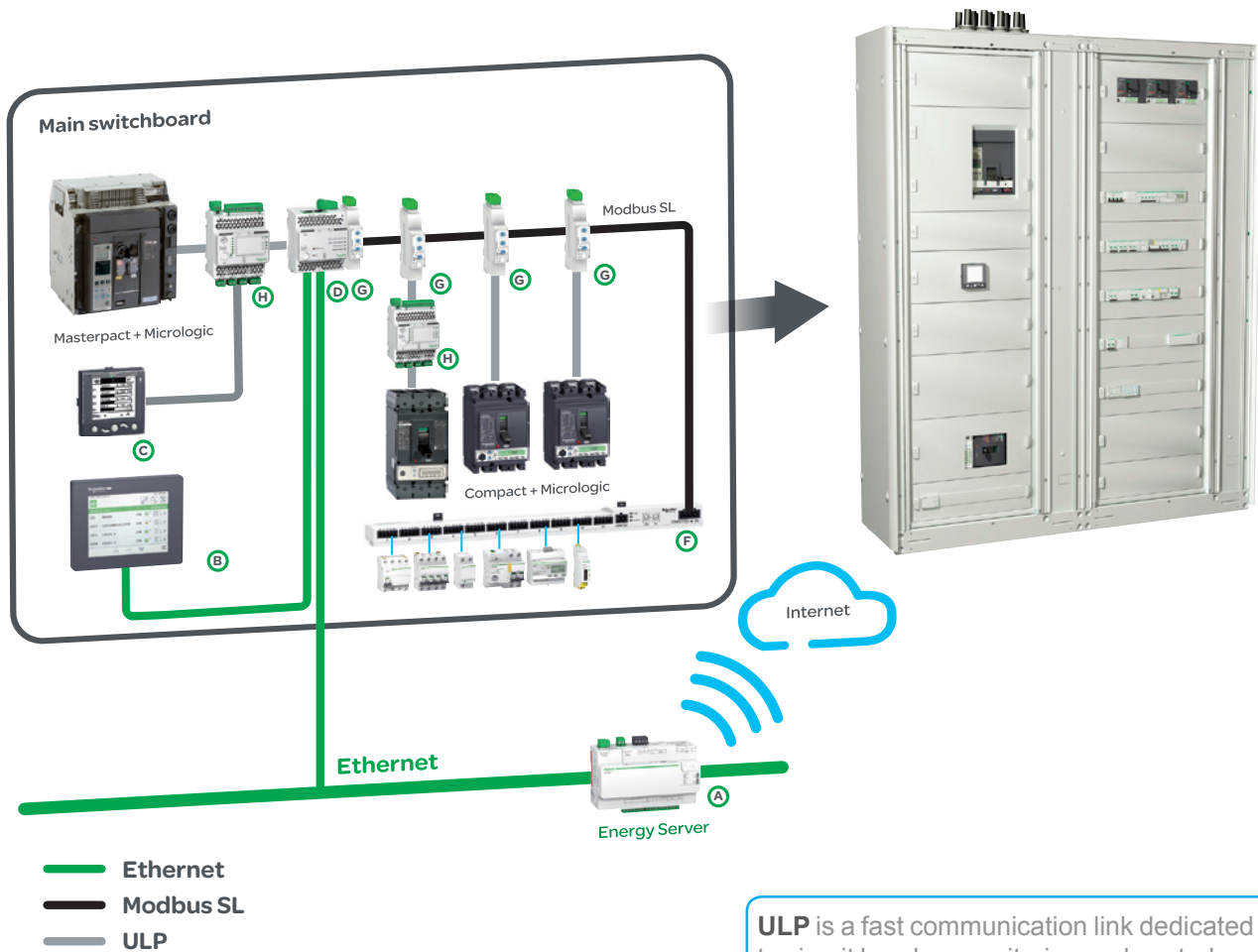



Products overview

Enerlin'X communication system provides access to status, electrical values and devices control using Ethernet and Modbus SL communication protocols.

Ethernet has become the universal link between switchboards, computers and communication devices inside the building. The large amount of information which can be transferred makes the connection of Enerlin'X digital system to hosted web services of Schneider Electric a reality. More advantages are offered to integrators thanks to configuration web pages available remotely or on the local Ethernet network.

Modbus SL is the most widely used communication protocol in industrial networks. It operates in master-slave mode. The devices (slaves) communicate one after the other with a gateway (master).



Enerlin'X communication devices and displays							
	Name	Function	Port		Bin. Input	Analog. Input	Bin. Output
			(to device)	(to server)			
 	Com'X 200	Energy Server with Ethernet Gateway® function	Modbus Master	Ethernet cable + WiFi	6	2	-
 	FDM128	Ethernet LCD colour touch screen	-	Ethernet	-	-	-
 	FDM121	LCD display for circuit breaker	ULP	-	-	-	-
 	IFE interface + gateway	Ethernet interface & Gateway®	Modbus Master & ULP	Ethernet	-	-	-
	IFE interface	Ethernet interface for circuit breakers	ULP	Ethernet	-	-	-
 	IFM	Modbus interface for circuit breakers	ULP	Modbus Slave	-	-	-
 	I/O	Input/Output application module for circuit breakers	ULP	ULP	6	1	1

Communication

Communication wiring system

Wiring system ULP

The wiring system is designed for low-voltage power switchboards. Installation requires no tools or special skills. The prefabricated wiring ensures both data transmission (Modbus protocol) and 24 V DC power distribution for the communications modules on the Micrologic control units.

PD1001800.eps

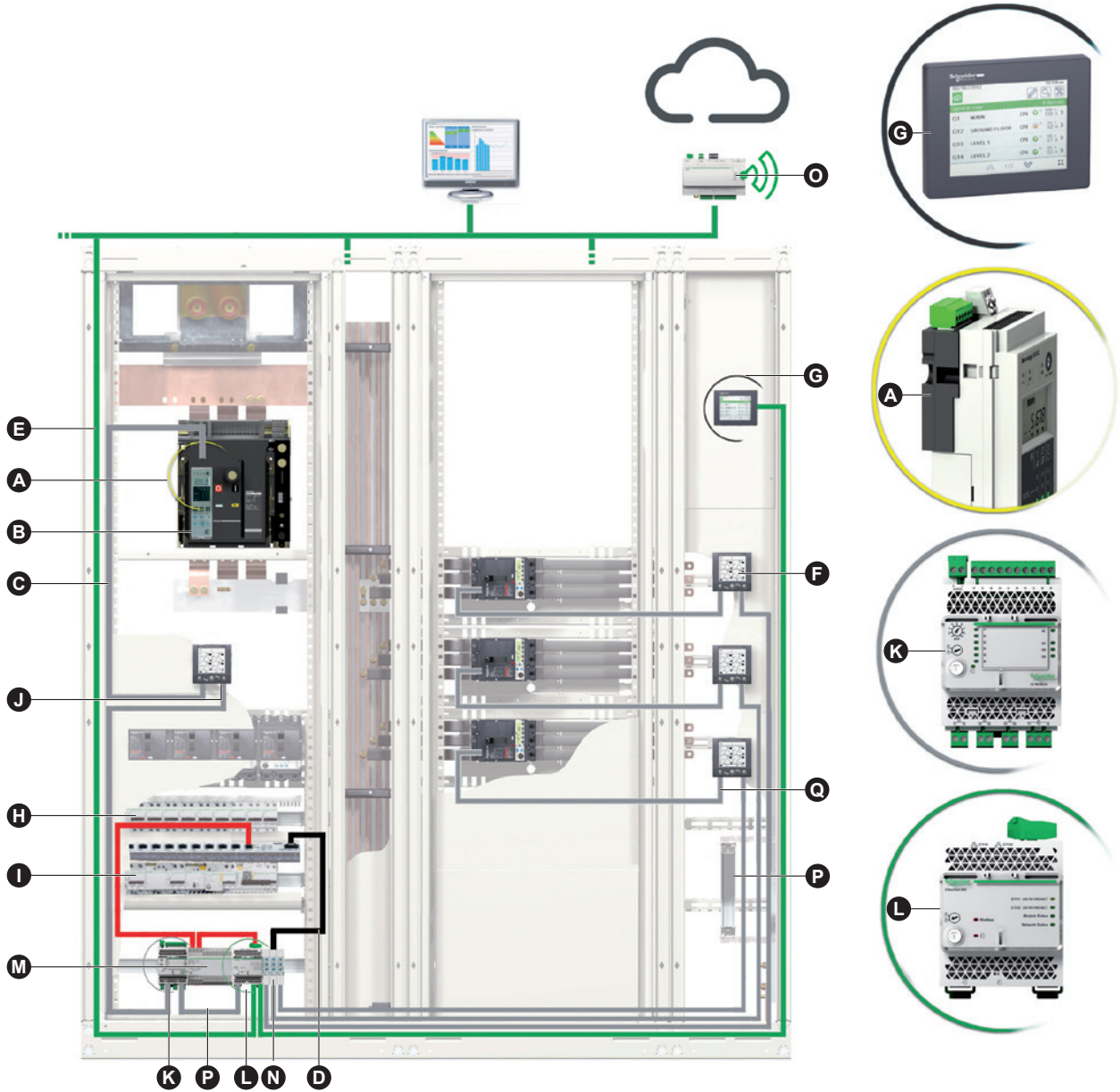

- A** BCM ULP: Breaker Communication Module with ULP port
- B** Micrologic control unit
- C** Breaker ULP cord

0.35 m	LV434195
1.3 m	LV434196
3 m	LV434197
- D** Modbus cable
- E** Ethernet cable
- F** FDM121: Front Display Module TRV00121
- G** FDM128: Front Display Module LV434128
- H** Smart Link A9XMSB11
- I** Acti9
- J** ULP line terminators TRV00880
- K** Input/Output interface LV434063

- L** IFE: Ethernet interface LV434010 or LV434011
- M** External 24 V DC power supply module
- N** IFM: Modbus-SL interface TRV00210
- O** Com'X 200
- P** ULP cable

0.3 m	TRV00803
0.6 m	TRV00806
1 m	TRV00810
2 m	TRV00820
3 m	TRV00830
5 m	TRV00850
- Q** NSX cord

0.35 m	LV434200
1.3 m	LV434201
3 m	LV434202

— Ethernet
— ULP
— Modbus
— 24 V DC

Available information and functions

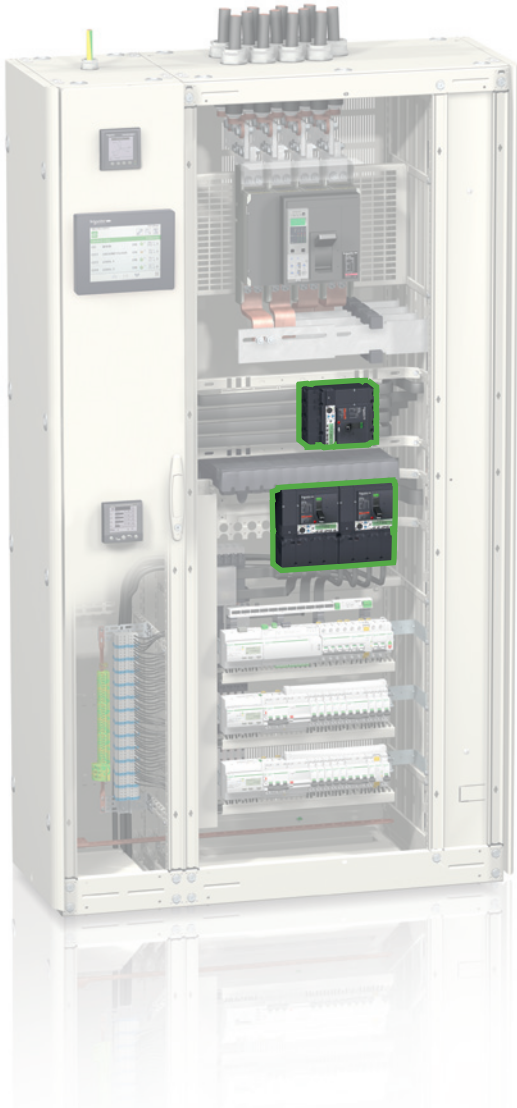

Micrologic trip units for 3 poles, PowerPact circuit breakers.

Available functions	Micrologic type
Status indications	
ON/OFF (O/F)	E
Spring charged CH	E
Ready to close	E
Fault-trip SDE	E
Connected / disconnected / test position CE/CD/CT (CCM only)	E
Controls	
MX1 open	E
XF close	E
Measurements	
Instantaneous measurement information	E
Averaged measurement information	E
Maximeter / minimeter	E
Energy metering	E
Demand for current and power	E
Power quality	
Operating assistance	
Protection and alarm settings	
Histories	E
Time stamped event tables	
Maintenance indicators	E

Embedded trip unit and communication module



Micrologic trip unit

All PowerPact circuit breakers are equipped with a Micrologic trip unit. This adjustable unit is mainly designed for tripping the circuit breaker in case of necessity and monitoring the downstream circuit. Alarms may be programmed for remote indications. Electrical measurements, operation data for predictive maintenance, are provided for local display or distant monitoring.

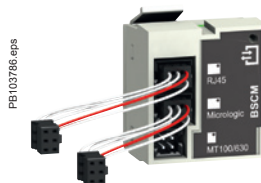

BSCM module.

BSCM module

Functions

The optional BSCM Breaker Status & Control Module is used to acquire device status indications and control the communicating remote-control function. It includes a memory used to manage the maintenance indicators.

Status indications

Indication of device status: O/F, SD and SDE.

Maintenance indicators

The BSCM module manages the following indicators:

- mechanical operation counter
- electrical operation counter
- history of status indications.

It is possible to assign an alarm to the operation counters.

Controls

The module can be used to carry out communicating remote control operations: (open, close and reset) in different modes (manual, auto).

Mounting

The BSCM module can be installed on all PowerPact. It simply clips into the auxiliary contact slots. It occupies the slots of one O/F contact and one SDE contact. The BSCM is supplied with 24 V DC power automatically via the NSX cord when the communication system is installed.

IFE Ethernet interface

PB112036-55-eps



IFE interface, ref.: LV434010

DB416830-eps



IFE interface + gateway, ref.: LV434011

DB406740-eps

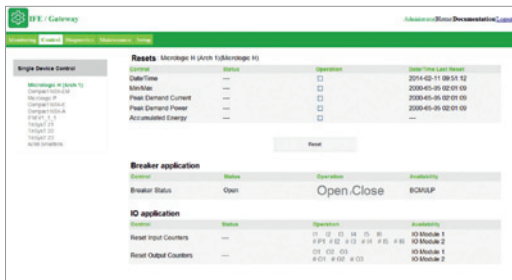

IFE interface, IFE interface + gateway description

Introduction

The IFE interface and IFE interface + gateway enable LV circuit breakers as Masterpact NT/NW, Compact NSX or Powerpact to be connected to an Ethernet network.

IFE interface: ref. LV434010

Provides an Ethernet access to a single LV circuit breaker.

Function

Interface - one circuit breaker is connected to the IFE interface via its ULP port.

IFE interface + gateway: ref. LV434011

Provides an Ethernet access to one or several LV circuit breakers.

Functions

- Interface - one circuit breaker is connected to the IFE interface via its ULP port.
- Gateway: several circuit breakers on a Modbus network are connected via the IFE interface + gateway master Modbus port.

IFE interface, IFE interface + gateway features

- Dual 10/100 Mbps Ethernet port for simple daisy chain connection.
- Device profile web service for discovery of the IFE interface, IFE interface + gateway on the LAN.
- ULP compliant for localization of the IFE interface in the switchboard.
- Ethernet interface for Compact, Masterpact and Powerpact circuit breakers.
- Gateway for Modbus-SL connected devices (IFE interface + gateway only).
- Embedded set-up web pages.
- Embedded monitoring web pages.
- Embedded control web pages.
- Built-in e-mail alarm notification.

Mounting

The IFE interface, IFE interface + gateway are DIN rail mounting devices. A stacking accessory enables the user to connect several IFMs (ULP to Modbus interfaces) to an IFE interface + gateway without additional wiring.

24 V DC power supply

The IFE interface, IFE interface + gateway must always be supplied with 24 V DC. The IFMs stacked to an IFE interface + gateway are supplied by the IFE interface + gateway, thus it is not necessary to supply them separately. It is recommended to use an UL listed and recognized limited voltage/limited current or a class 2 power supply with a 24 V DC, 3 A maximum.

IFE interface, IFE interface + gateway firmware update

The firmware can be updated using:

- FTP
- customer engineering tool.

Required circuit breaker communication modules

The connection to IFE interface or IFE interface + gateway requires a communication module embedded into the circuit breaker:

- Compact NSX: NSX cord and/or BSCM module

The insulated NSX cord is mandatory for system voltages greater than 480 V AC. When the second ULP RJ45 connector is not used, it must be closed with an ULP terminator (TRV00880).

Network communication interface

Characteristic		Value
Type of interface module		Modbus RTU, RS485 serial connection Modbus TCP/IP Ethernet
Transmission	Modbus RS485	Transfer rate: 9,600...19,200 Baud Medium Double shielded twisted pair Impedance 120 Ω
	Ethernet	Transfer rate : 10/100 Mbps Medium STP, Cat5e, straight cable
Structure	Type	Modbus, Ethernet
	Method	Master/Slave
Device type	Modbus	Master
	Ethernet	Server
Turnaround time	Modbus	10 ms
	Ethernet	1 ms
Maximum length of cable	Modbus	1000 m
	Ethernet	100 m
Type of bus connector	Modbus	4-pin connector
	Ethernet	RJ45 (Shielded)

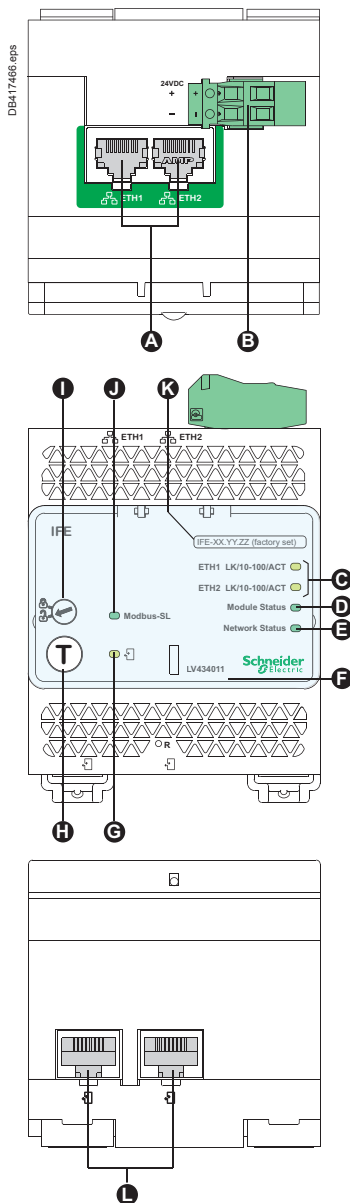

- A** Ethernet 1 and Ethernet 2 communication port.
- B** 24 V DC power supply terminal block.
- C** Ethernet communication LEDs:
 - yellow: 10 Mb
 - green: 100 Mb.
- D** Module status LED:
 - steady off: no power
 - steady green: device operational
 - steady red: major fault
 - flashing green: standby
 - flashing red: minor fault
 - flashing green/red: self-test.
- E** Network status LED:
 - steady off: not power/no valid IP address
 - steady green: connected, valid IP address
 - steady orange: default IP address
 - steady red: duplicated IP address
 - flashing green/red: Self-test.
- F** Sealable transparent cover.
- G** ULP status LED.
- H** Test button (accessible closed cover).
- I** Locking pad.
- J** Modbus traffic status LED (LV434011 only).
- K** Device name label.
- L** ULP ports.

General characteristics

Environmental characteristics

Conforming to standards	UL 508, UL 60950, IEC 60950, 60947-6-2
Certification	cULUs, GOST, FCC, CE
Ambient temperature	-20 to +70 °C (-4 to +158 °F)
Relative humidity	5–85 %
Level of pollution	Level 3
Flame resistance	ULV0

Mechanical characteristics

Shock resistance	1000 m/s ²
Resistance to sinusoidal vibrations	-5 Hz < f < 8.4 Hz

Electrical characteristics

Resistance to electromagnetic discharge	Conforming to IEC/EN 61000-4-3
Immunity to radiated fields	10 V/m
Immunity to surges	Conforming to IEC/EN 61000-4-5
Consumption	120 mA at 24 V input

Physical characteristics

Dimensions	72 x 105 x 71 mm (2.83 x 4.13 x 2.79 in.)
Mounting	DIN rail
Weight	182.5 g (0.41 lb)
Degree of protection of the installed IO	<ul style="list-style-type: none"> ■ On the front panel (wall mounted enclosure): IP4x ■ Connectors: IP2x ■ Other parts: IP3x

Connections	Screw type terminal blocks
-------------	----------------------------

Technical characteristics - 24 V DC power supply

Power supply type	Regulated switch type
Rated power	72 W
Input voltage	100–120 V AC for single phase 200–500 V AC phase-to-phase
PFC filter	With IEC 61000-3-2
Output voltage	24 V DC
Power supply out current	3 A

Note: it is recommended to use an UL listed/UL listed recognized limited voltage/Limited current or a class 2 power supply with a 24 V DC, 3 A maximum.

IFE web page description

Monitoring web page

Real time data 67	■
Device logging	■

Control web page

Single device control	■
-----------------------	---

Diagnostics web page

Statistics	■
Device information	■
IMU information	■
Read device registers	■
Communication check	■

Maintenance web page

Maintenance log	■
Maintenance counters	■

Setup web page

Device localization/name	■
Ethernet configuration (dual port)	■
IP configuration	■
Modbus TCP/IP filtering	■
Serial port	■
Date and time	■
E-mail server configuration	■
Alarms to be e-mailed	■
Device list	■
Device logging	■
Device log export	■
SNMP parameters	■
Documentation links	■
Preferences	■
Advanced services control	■
User accounts	■
Web page access	■

IFM Modbus communication interface



IFM Modbus communication interface.
Ref.: TRV00210.

Function

A IFM - Modbus communication interface - is required for connection of a Masterpact or Compact to a Modbus network as long as this circuit breaker is provided with a ULP (Universal Logic Plug) port. The port is available on respectively a BCM ULP or BSCM embedded module.

The IFM is defined as an IMU (Intelligent Modular Unit) in the ULP connection System documentation.

Once connected, the circuit breaker is considered as a slave by the Modbus master. Its electrical values, alarm status, open/close signals can be monitored or controlled by a Programmable Logic Controller or any other system.

Characteristics

ULP port

2 RJ45 sockets, internal parallel wiring.

- Connection of a single circuit breaker (eventually via its I/O application module).
- A ULP line terminator or an FDM121 display unit must be connected to the second RJ45 ULP socket.

The RJ45 sockets deliver a 24 VDC supply fed from the Modbus socket.

Built-in test function, for checking the correct connection to the circuit breaker and FDM121 display unit.

Modbus slave port

- Top socket for screw-clamp connector, providing terminals for:

- 24 VDC input supply (0V, +24V)
- Modbus line (D1, D2, Gnd).

- Lateral socket, for Din-rail stackable connector.

Both top and lateral sockets are internally parallel wired.

- Multiple IFM can be stacked, thus sharing a common power supply and Modbus line without individual wiring.

- On the front face:

- Modbus address setting (1 to 99): 2 coded rotary switches
- Modbus locking pad: enables or disable the circuit breaker remote control and modification of IFM parameters.

- Self adjusting communication format (Baud rate, parity).

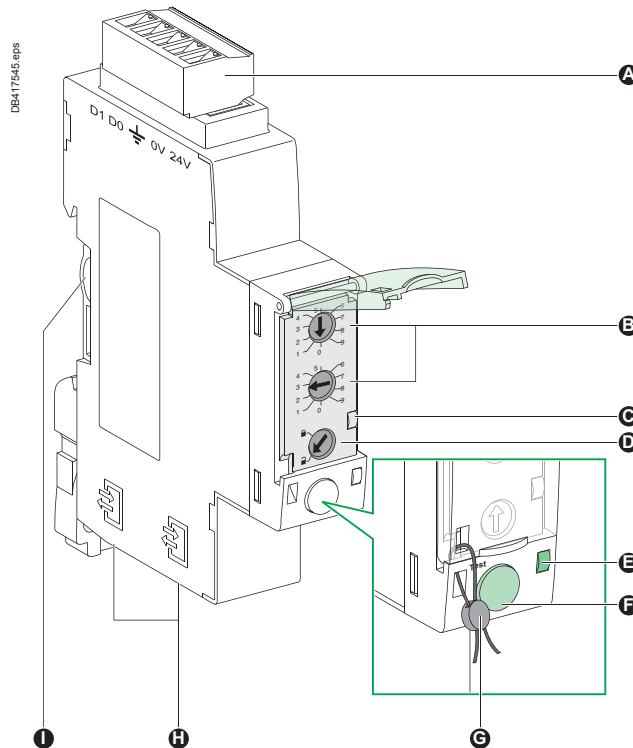

A Modbus screw clamp connector.

B Modbus address switches.

C Modbus traffic LED.

D Modbus locking pad.

E ULP activity LED.

F Test button.

G Mechanical lock.

H ULP RJ45 connectors.

I Stacking accessory connection.

IFM Modbus communication interface

Technical characteristics

IFM Modbus communication interface		
Dimensions		18 x 72 x 96 mm
Maximum number of stacked IFM		12
Degree of protection of the installed module	Part projecting beyond the escutcheon	IP4x
	Other module parts	IP3x
	Connectors	IP2x
Operating temperature		-25...+70 °C
Power supply voltage		24 V DC -20 %/+10 % (19.2...26.4 V DC)
Consumption	Typical	21 mA/24 V DC at 20 °C
	Maximum	30 mA/19.2 V DC at 60 °C
Certification		
CE		IEC/EN 60947-1
UL		UL 508 - Industrial Control Equipment
CSA		No. 142-M1987 - Process Control Equipment
		■ CAN/CSA C22.2 No. 0-M91 - General requirements - Canadian Electrical Code Part
		■ CAN/CSA C22.2 No. 14-05 - Industrial Control Equipment

Simplified IFM installation

Staking IFM

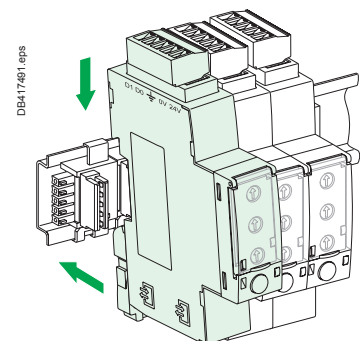
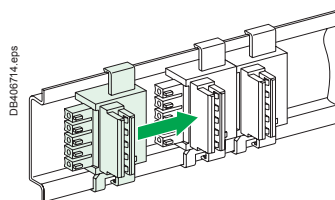

Stacking accessories

Up to 12 stacked IFM

Stacking an IFE interface + gateway with IFMs

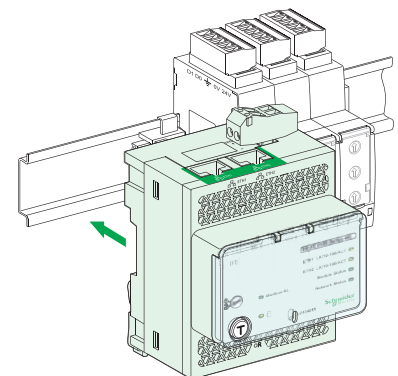
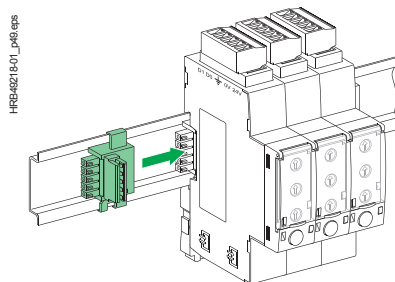

I/O application module



Description

The I/O input/output application module for LV breaker is part of an ULP system with built-in functionalities and applications to enhance the application needs. The ULP system architecture can be built without any restrictions using the wide range of circuit breakers.

The I/O application is compliant with the ULP system specifications.

Two I/O application module can be connected in the same ULP network.

The ranges of LV circuit breakers enhanced by the I/O are:

- Masterpact NW
- Masterpact NT
- Compact NS1600b-3200
- Compact NS630b-1600
- Compact NSX100-630 A.

I/O input/output interface for LV breaker resources

The I/O application module resources are:

- 6 digital inputs that are self powered for either NO and NC dry contact or pulse counter
- 3 digital outputs that are bistable relay (5 A maximum)
- 1 analog input for Pt100 temperature sensor.

Pre-defined applications

Pre-defined application adds new functions to the IMU in a simple way:

- selection by the application rotary switch on the I/O, defining the application with pre-defined input/output assignment and wiring diagram.
- no additional setting with the customer engineering tool required.

The resources not assigned to the pre-defined application are free for additional user-defined applications:

- cradle management
- breaker operation
- light and load control
- custom.

User-defined applications

User-defined applications are processed by the I/O in addition to the pre-defined application selected.

The user-defined applications are available depending on:

- the pre-defined application selected
- the I/O resources (inputs and outputs) not used by the application.

The resources required by user-defined applications are assigned using the customer engineering tool:

- protection
- control
- energy management
- monitoring.

Mounting

The I/O is a DIN rail mounting device.

Application rotary switch

The application rotary switch enables the selection of the pre-defined application.

It has 9 positions and each position is assigned to a pre-defined application.

The factory set position of the switch is pre-defined application 1.

Setting locking pad

The setting locking pad on the front panel of the I/O enables the setting of the I/O by the customer engineering tool.

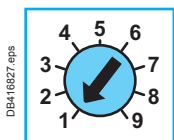

DB17467 eps

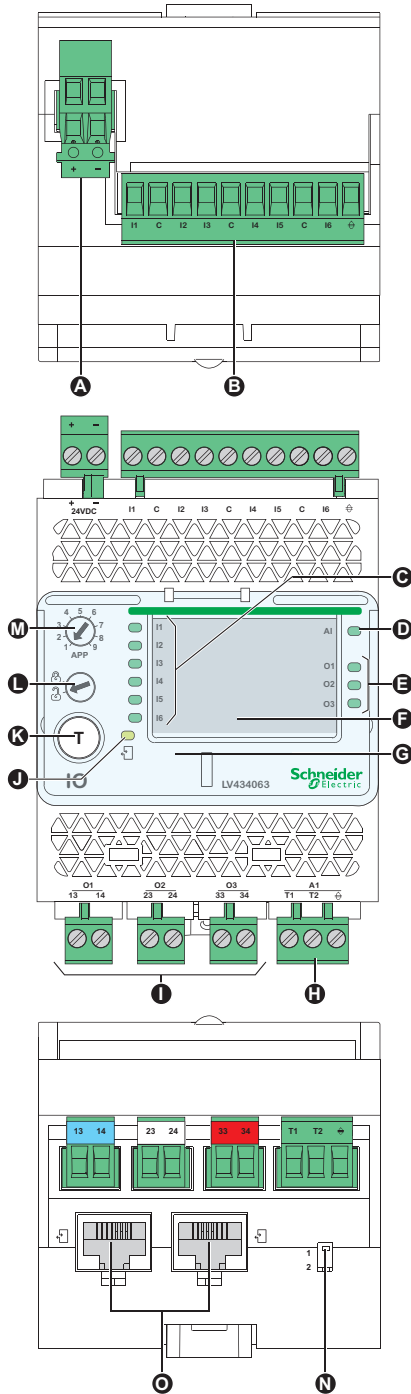

- A** 24 V DC power supply terminal block.
- B** Digital input terminal block: 6 inputs, 3 commons and 1 shield.
- C** 6 input status LEDs.
- D** Analog input status LED.
- E** 3 output status LEDs.
- F** I/O identification labels.
- G** Sealable transparent cover.
- H** Analog input terminal block.
- I** Digital output terminal blocks.
- J** ULP status LED.
- K** Test/reset button (accessible with cover closed).
- L** Setting locking pad.
- M** Application rotary switch: 1 to 9.
- N** Switch for IO addressing (IO 1 or IO 2).
- O** ULP connectors.

General characteristics

Environmental characteristics

Conforming to standards	UL 508, UL 60950, IED 60950, 60947-6-2
Certification	cUIUs, GOST, FCC, CE
Ambient temperature	-20 to +70 °C (-4 to +158 °F)
Relative humidity	5–85 %
Level of pollution	Level 3
Flame resistance	ULV0

Mechanical characteristics

Shock resistance	1000 m/s ²
Resistance to sinusoidal vibrations	-5 Hz < f < 8.4 Hz

Electrical characteristics

Resistance to electromagnetic discharge	Conforming to IEC/EN 61000-4-3
Immunity to radiated fields	10 V/m
Immunity to surges	Conforming to IEC/EN 61000-4-5
Consumption	165 mA

Physical characteristics

Dimensions	71.7 x 116 x 70.6 mm (2.83 x 4.56 x 2.78 in.)
Mounting	DIN rail
Weight	229.5 g (0.51 lb)
Degree of protection of the installed IO	<ul style="list-style-type: none"> ■ On the front panel (wall mounted enclosure): IP4x ■ IO parts: IP3x ■ Connectors: IP2x
Connections	Screw type terminal blocks

Technical characteristics - 24 V DC power supply

Power supply type	Regulated switch type
Rated power	72 W
Input voltage	100–120 V AC for single phase 200–500 V AC phase-to-phase
PFC filter	With IEC 61000-3-2
Output voltage	24 V DC
Power supply out current	3 A

Note: it is recommended to use an UL listed/UL listed recognized limited voltage/Limited current or a class 2 power supply with a 24 V DC, 3 A maximum.

Digital inputs

Digital input type	Self powered digital input with current limitations as per IEC 61131-2 type 2 standards (7 mA)
Input limit values at state 1 (close)	19.8–25.2 V DC, 6.1–8.8 mA
Input limit values at state 0 (open)	0–19.8 V DC, 0 mA
Maximum cable length	10 m (33 ft)

Note: for a length greater than 10 m (33 ft) and up to 300 m (1,000 ft), it is mandatory to use a shielded twisted cable. The shield cable is connected to the IO functional ground of the IO.

Digital outputs

Digital output type	Bistable relay
Rated load	5 A at 250 V AC
Rated carry current	5 A
Maximum switching voltage	380 V AC, 125 V DC
Maximum switch current	5 A
Maximum switching power	1250 VA, 150 W
Minimum permissible load	10 mA at 5 V DC
Contact resistance	30 mΩ
Maximum operating frequency	<ul style="list-style-type: none"> ■ 18000 operations/hr (Mechanical) ■ 1800 operations/hr (Electrical)
Digital output relay protection by an external fuse	External fuse of 5 A or less
Maximum cable length	10 m (33 ft)

Analog inputs

The IO analog input can be connected to a Pt100 temperature sensor		
Range	-30 to 200 °C	-22 to 392 °F
Accuracy	±2 °C from -30 to 20 °C	±3.6 °F from -22 to 68 °F
	±1 °C from 20 to 140 °C	±1.8 °F from 68 to 284 °F
	±2 °C from 140 to 200 °C	±3.6 °F from 284 to 392 °F
Refresh interval	5 s	5 s

Communication

Communications modules, IFM and IFE

All PowerPact devices can be equipped with the communication function via a prewired connection system and a Modbus or Ethernet network interface. The interface can be connected directly or via the FDM121 switchboard display unit. Four functional levels can be combined to adapt to all supervision requirements.

Four functional levels

The PowerPact can be integrated in a Modbus or Ethernet communication environment. Four functional levels can be used separately or combined.

Communication of status indications

This level is compatible with all Compact NSX circuit breakers, whatever the trip unit, and with all switch-disconnectors. Using the BSCM module, the following information is accessible:

- ON/OFF position (O/F)
- trip indication (SD)
- fault-trip indication (SDE).

Communication of commands

Also available on all circuit breakers and switch-disconnectors, this level (communicating remote control) can be used to:

- open
- close
- reset.

Communication of measurements with Micrologic 5 E

This level provides access to all available information:

- instantaneous values E
- demand values E
- maximeters/minimeters E
- energy metering E
- demand current and power E
- power quality E.

Communication of operating assistance with Micrologic 5 E

- protection and alarm settings E
- time-stamped histories E
- event tables E
- maintenance indicators E.

Modbus principle

The Modbus RS 485 (RTU protocol) system is an open bus on which communicating Modbus devices (Compact NS with Modbus COM, Power Meter PM700, PM800, Sepam, Vigilohm, Compact NSX, etc.) are installed. All types of PLCs and microcomputers may be connected to the bus.

Addresses

The Modbus communication parameters (address, baud rate, parity) are entered using the keypad on the Micrologic E. For a switch-disconnector, it is necessary to use the Electrical Asset Manager or RSU (Remote Setting Utility) Micrologic utility.

Number of devices

The maximum number of devices that may be connected to the Modbus bus depends on the type of device (Compact with Modbus COM, PM700, PM800, Sepam, Vigilohm, Compact NSX, etc.), the baud rate (19200 is recommended), the volume of data exchanged and the desired response time. The RS 485 physical layer offers up to 32 connection points on the bus (1 master, 31 slaves).

A fixed device requires only one connection point (communication module on the device). A drawout device uses two connection points (communication modules on the device and on the chassis).

The number must never exceed 31 fixed devices or 15 drawout devices.

Length of bus

The maximum recommended length for the Modbus bus is 1200 meters.

Bus power source

A 24 V DC power supply is required (less than 20 % ripple, insulation class II).

Ethernet principle

Ethernet is a data link and physical layer protocol defined by IEEE 802.10 and 100 Mbps specifications that connects computer or other Ethernet devices. Ethernet is an asynchronous Carrier Sense Multiple Access with Collision detection (referred as CSMA/CD) protocol. Carrier Sense means that the hosts can detect whether the medium (coaxial cable) is idle or busy. Multiple Access means that multiple hosts can be connected to the common medium. Collision Detection means a host detects whether its transmission has collided with the transmission of another host (or hosts). IFE Ethernet interface can be connected to a PC or a laptop over Ethernet. The maximum length of Ethernet cable is 100 meters. IFE Ethernet interface + gateway provides a Modbus TCP/IP gateway over Ethernet to enable Modbus TCP communication from a Modbus TCP master to any Modbus slave devices connected to it. The maximum active Modbus TCP client connection is twelve.

IFE Ethernet interface has an embedded web server (web page).

The Modbus RS 485 (RTU protocol) system is an open bus on which communicating Modbus devices (Compact NS with Modbus COM, Power Meter PM700, PM800, Sepam, Vigilohm, Compact NSX, etc.) are installed. All types of PLCs and microcomputers may be connected to the bus.

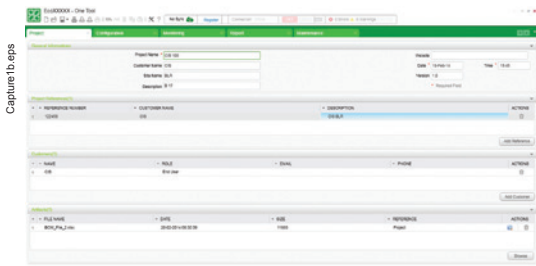

Capture1b.eps

Introduction

Electrical Asset Manager is a software application that helps the user to manage a project as part of designing, testing, site commissioning, and maintenance of the project life cycle.

It enables the user to prepare the settings of the devices offline (without connecting to the device) and configure them when connected with the devices.

Also it provides lot of other value added features for the user to manage the project such as, safe repository in cloud, attach artifacts to each device or at the project level, organize devices in switchboard wise, manage a hierarchical structure of the installation etc.

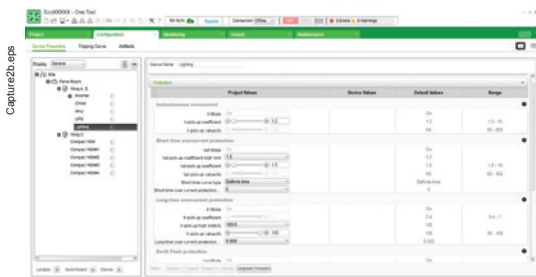

Capture2b.eps

Compatible devices (configuration and device management)

Electrical Asset Manager is compatible with the following devices:

- Compact NSX100-630 (IEC)
- PowerPact™ (UL) circuit breaker
- Compact NS630b-3200 (IEC)
- Masterpact NT/NW (IEC and UL) circuit breaker
- Acti9 Smartlink.
- Compatible devices (Device Management in the project)
- Switch disconnectors (Compact NSX, Masterpact & PowerPact Family)
- Third party devices.

References:

Electrical Asset Manager software package can be downloaded from our website www.schneider-electric.com.

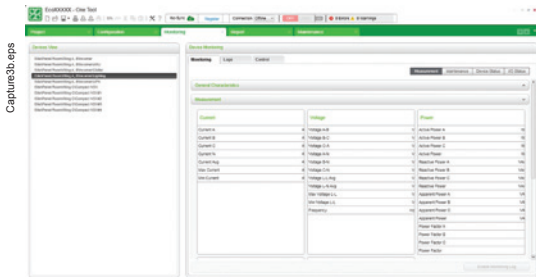

Capture3b.eps

Features

Electrical Asset Manager supersedes the Schneider Electric customer engineering tools such as Remote setting Utility (RSU) and Remote Control Utility (RCU) with additional features.

Electrical Asset Manager supports the connection of Schneider Electric communicable devices to:

- create projects by device discovery, selection of devices, and import Bill of Material (BOM)
- monitor the status of protection and IO status
- read information (alarms, measurements, parameters)
- check protection discrimination between two devices
- upload and download of configuration or settings in batch mode to multiple devices.
- carry out commands and tests
- generate and print device settings report and communication test report
- manage multiple devices with electrical and communication hierarchy model
- manage artifacts (project documents)
- check consistency in settings between devices on a communication network
- compare configuration settings between PC and device (online)
- download latest firmware.

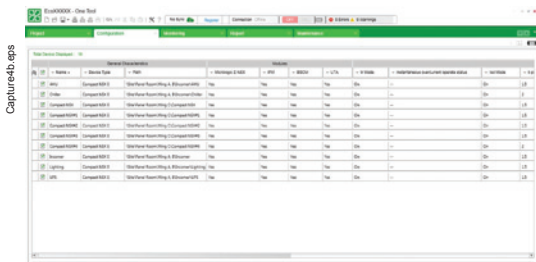

Capture4b.eps

Electrical Asset Manager enables the user to avail the advanced features of the software once the project is saved in Schneider Electric cloud.

Electrical Asset Manager

CaptureBugs

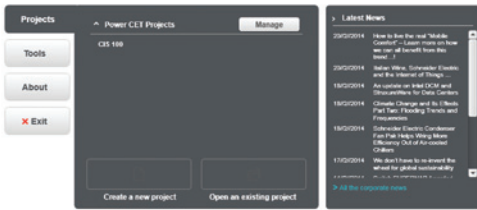

Functions

Offline Mode

A project can be built in offline mode through 2 different ways:

- through BOM file import
- through Device Selection.

Additionally, the user can open an existing project and modify the settings offline. The user can do the discrimination curve check and firmware compatibility check for devices in the project.

Online Mode

A project can be built in online mode through device discovery also other than the methods possible through offline method.

Once the project is built, the following functions can be performed in addition to the functions available in offline mode:

- compare the device parameters with project parameters
- load parameters from project to the device and vice versa
- firmware downloads to the device
- monitor the measurement, maintenance, device status and I/O status
- control functions.

User Interface

Electrical Asset Manager software provides fast direct access to the project and the devices in the project through different tabs.

- Project: to provide the project information including customer details, project references and to add project artifacts (documents related to the project).
- Configuration: to build up the tree structure of the project architecture ; to have a table view of the devices added in the project ; to set the parameters of the devices ; to transfer the device settings ; to view the tripping curves; to attach device artifacts and to download the latest firmware, to do the communication test for all the devices and generate the test report.
- Monitoring: this allows the user to monitor the real time values of different devices through different sub tabs namely Monitoring, Logs and Control.
- Reports: report tab allows you to generate and print a report of the project settings from the report tab. The user details and project characteristics are automatically filled with the details entered in the Project page.

CaptureBugs

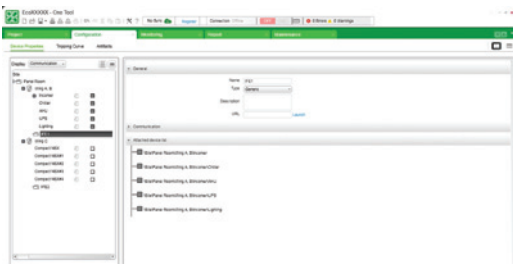

CaptureBugs

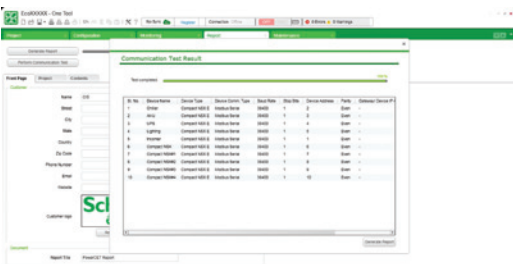

CaptureBugs

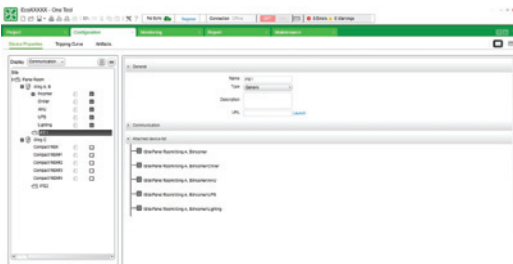



24 V DC Terminal block



External 24 V DC Power-Supply Module.



Pocket Tester.



Battery Module.

External Neutral Current Transformer (ENCT)

The external neutral current transformer is a sensor required for a three-pole circuit breaker in a system with a distributed neutral to measure the neutral current in order to:

- protect the neutral conductor
- protect against ground faults.

This current transformer can be connected to Micrologic 5 trip unit. The transformer rating must be compatible with that of the circuit breaker.

24 V DC power-supply terminal block

The Micrologic 5 trip unit display is operational when current is flowing through the circuit breaker.

To power the Micrologic 5 trip unit when the trip unit is not connected to an FDM121 or to the communication network, a 24 V DC power-supply terminal block can be installed only on Micrologic 5 trip unit. When used, it excludes connection of an NSX cord.

External 24 V DC power-supply module

An external 24 V DC power supply is required for installation in a communication network, whatever the type of trip unit.

On installations without a communication network, the power supply is available as an option for Micrologic 5 trip unit in order to:

- modify settings when the circuit breaker is open
- display measurements when the current flowing through the circuit breaker is low (15 to 50 A depending on the rating)
- maintain the display of the cause of tripping and interrupted current.

A single external 24 V DC supply may be used for the entire network, depending on the number of devices in the communication network.

The required characteristics are:

- output voltage: 24 V DC $\pm 5\%$
- ripple: $\pm 1\%$.

Total consumption

To determine the required output current of the 24 V DC power supply, it is necessary to sum up the currents consumed by the different loads supplied:

Power requirements Module	Power requirements at 24 V DC
Micrologic 5 trip unit	40 mA
BSCM module	10 mA
FDM121 Module	40 mA
Modbus communication interface module	60 mA
NSX cord V > 480 V AC	30 mA
SDx Module	20 mA

For installation recommendations, see [page A-56](#).

Pocket Tester

The pocket tester connects to the Micrologic trip unit test connector. It powers up the Micrologic trip unit and the Ready LED. It supplies the screen, allows settings to be made using the keypad, and provides thermal memory inhibit functions.

The pocket tester runs off of two Alkaline AA batteries.

Battery Module

The battery module is a back-up supply for the external power-supply module. The input/output voltages are 24 V DC and it can supply power for approximately three hours (100 mA).

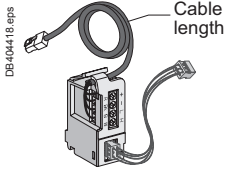

NSX Cord,
 $V \leq 480 V$.



NSX Cord,
 $V > 480 V$.

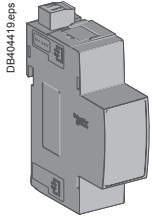

Isolation Module
for NSX Cord,
with $V > 480 V$.

NSX Cord

Micrologic trip units are connected to the Modbus communication interface module (IFM) or front display module through the internal terminal block for the NSX cord equipped with an RJ45 connector.

The NSX cord is available in three cable lengths:

- 1.3 m (4.27 ft)
- 3 m (9.84 ft).

Lengths up to 10 m (32.8 ft) are possible using extensions.

- For voltage $V \leq 480 V$, available in 3 prefabricated lengths: 0.35 m, 1.3 m and 3 m.
- For voltages $V > 480 V$, a special 1.3 m cable with an insulation accessory is required.
- A set of cables with RJ45 connectors is available to adapt to different distances between devices.

DB417738.eps

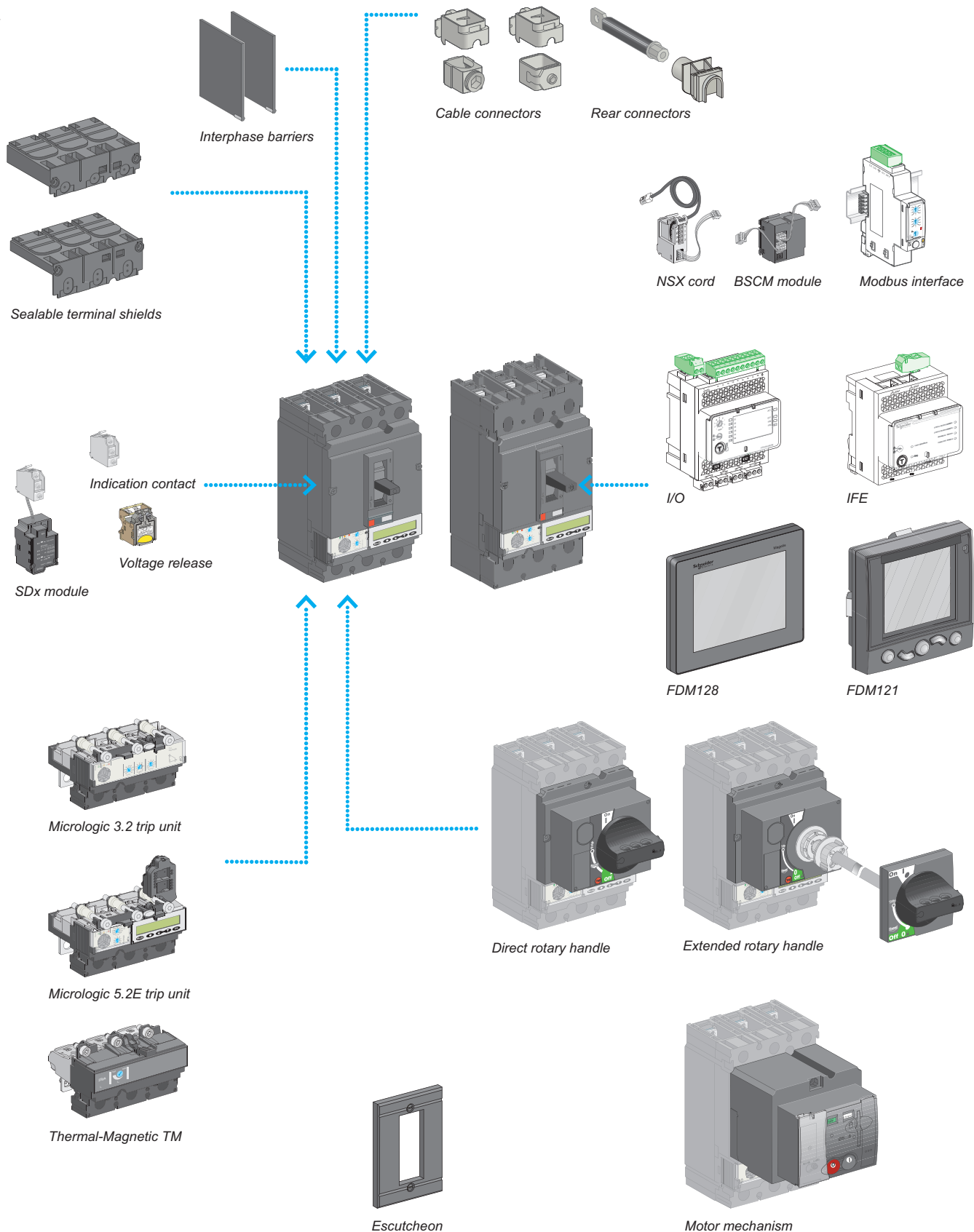

Overview of PowerPact L- frame

DB417739.eps

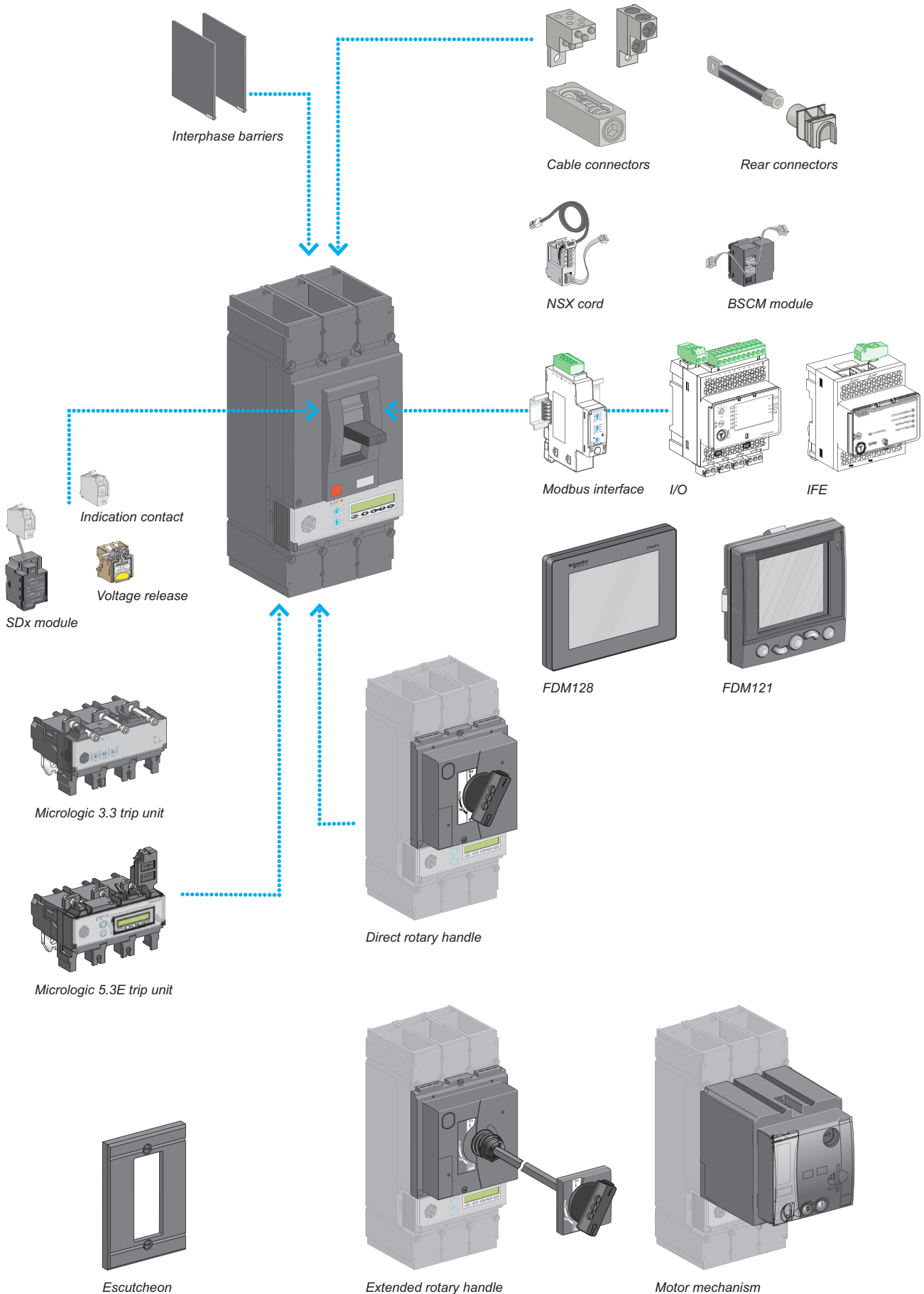

The standard lugs can be removed for the installation of compression-type lugs or bus connections.

All lugs are UL Listed/CSA Certified for their proper application and marked for use with aluminum and copper (Al/Cu) or copper only (Cu) conductors. Lugs suitable for copper and aluminum conductors are made of tin-plated aluminum.

Mounting

H-, J-, and L-frame circuit breakers may be mounted vertically, horizontally or flat on their back without any derating of characteristics.

Unit-mount H- and J-frame circuit breakers are supplied with two mounting screws, unit-mount L-frame circuit breakers are supplied with four mounting screws. These mounting screws are inserted through mounting holes molded into the circuit breaker case and threaded into the mounting enclosure, rails or through the panel door for flush mounting.

A DIN rail mounting bracket (cat. no. S29305) is available for the H- and J-frame circuit breakers.

Note: DIN rail mounting is not compatible with motor operated applications.

Unit-mounting options

H-, J-Frame circuit breakers (2 mounting screws)

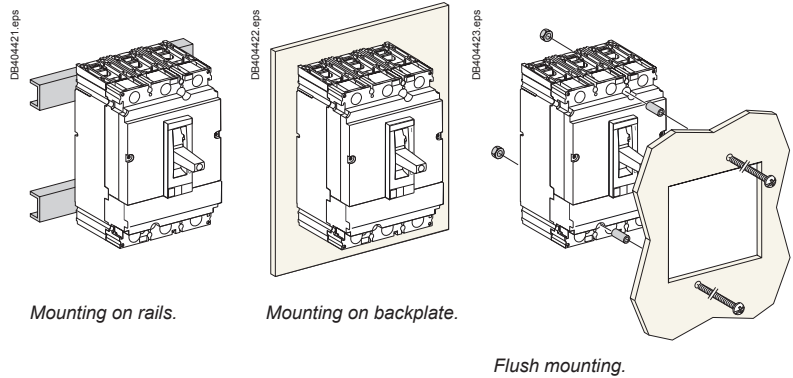

L-Frame circuit breakers (4 mounting screws)

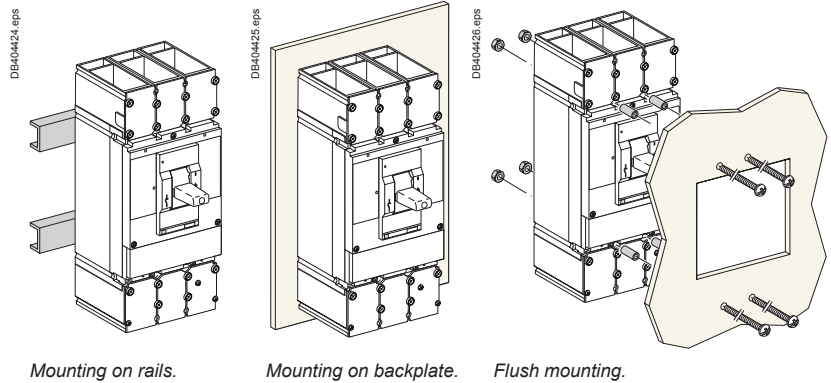

Rear connection

For connection of bus bars or cables with compression lugs. Rear connections are easily installed on the circuit breaker terminals. The same connection may be installed flat, edgewise or at a 45° angle. All combinations are possible. The circuit breaker is mounted on a backplate.

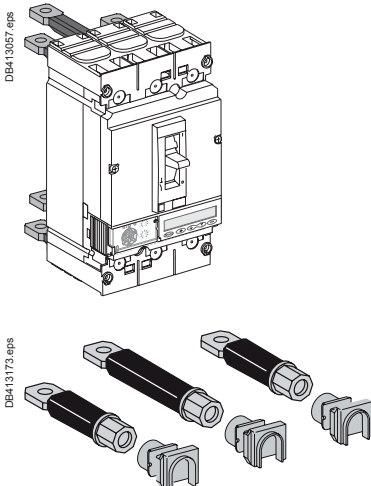
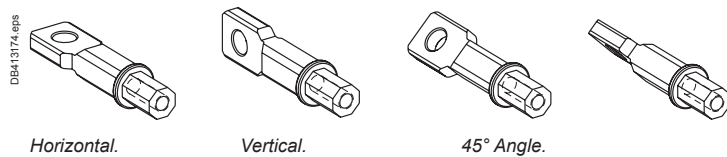

One long and two short.

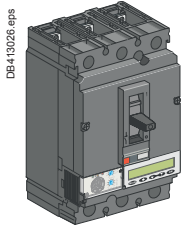

15/150 A lug.

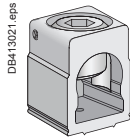

15/175 A lug.

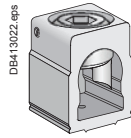

200/250 A lug.

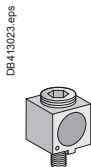

400 A lug.

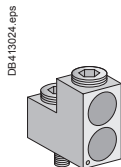

600 A lug.

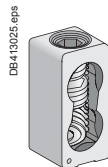

600 A lug.

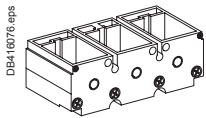

Terminal shield.

Mechanical lug kits

Unit-mount H-, J-, and L-frame circuit breakers can be ordered with mechanical line and load side lugs. The standard lugs can be removed for the installation of compression-type lugs or bus connections. All lugs are UL Listed/CSA Certified for their proper application and marked for use with aluminum and copper (Al/Cu) or copper only (Cu) conductors. Lugs suitable for copper and aluminum conductors are made of tin-plated aluminum. Lugs suitable for use with copper conductors only are made of copper.

Mechanical lugs PowerPact Multistandard lay on top of the circuit breaker terminals and can be installed without the use of any tools. The lugs are held in place with snap features built into the insulating retainer and are secured with the clamp force applied to the wire binding screw.

Mechanical lugs are sold either factory installed or as field installable kits.

Mechanical lug kits for H-Frame and J-Frame circuit breakers

Al lugs for use with Al or Cu wire

Circuit breaker application				Number of wires per lug and wire range	Qty per kit
Standard	Ampere rating	Optional	Ampere rating		
HD, HG, HJ	15-150 A			(1) 14-3/0 AWG Al or Cu	3
JD, JG, JJ	150-175 A			4-4/0 AWG Al or Cu	3
JD, JG, JJ	200-250 A	JD, JG, JJ	150-175 A	3/0-350 kcmil Al or Cu	3

Mechanical lug kits for L-Frame circuit breakers

Al lugs for use with Al or Cu wire

Circuit breaker application			Number of wires per lug and wire range ⁽¹⁾	Qty per kit
Ampere rating	Poles	Unit mount		
250	3	■	(1) 2 AWG - 500 kcmil Al	3
400/600	3	■	(2) 2/0 AWG - 500 kcmil Al or Cu	3
400/600	3	■	(2) 3/0 AWG - 500 kcmil Al or Cu	3

⁽¹⁾ For control wire installation, use an 8-32 x 1/4 in. screw (not provided) into tapped control wire hole in lower left hand corner of lug.

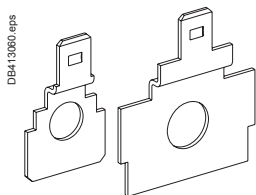
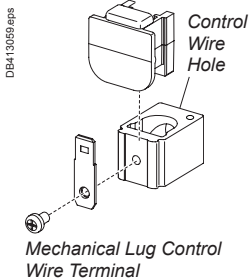
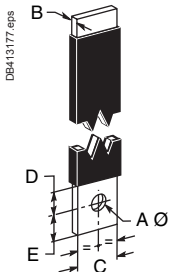
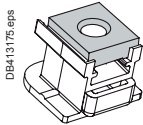
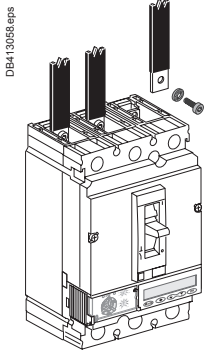

Busbar Control Wire Terminal.

Control tape takeoff.

Busbar connections

The H-, J- and L-frame circuit breakers may be equipped with captive nuts and screws for direct connection to bars or to compression (crimp) lugs

For H- and J-frame, these are readily field-installable, simply by removing the mechanical lug and replacing with the appropriate terminal nut. They are also available factory-installed.

For L-frame, the mechanical lug can be removed, leaving the threaded nut insert intact.

Terminal nuts for busbar connection of H-Frame and J-Frame circuit breakers

Description	Frame	Tap	Qty per kit	Torque
H-Frame terminal nut insert-english	HD/HG/HJ	1/4-20	2	9–10.2 N•m (80-90 lb-in)
H-Frame terminal nut insert-english	HD/HG/HJ	1/4-20	3	
H-Frame terminal nut insert-metric	HD/HG/HJ	M6	2	
J-Frame terminal nut insert-english	JD/JG/JJ	1/4-20	2	9–10.2 N•m (80-90 lb-in)
J-Frame terminal nut insert-english	JD/JG/JJ	1/4-20	3	
J-Frame terminal nut insert-metric	JD/JG/JJ	M8	2	

Bar dimensions

Dimension	A	B	C	D	E
H-Frame	6.4 mm (0.250 in.)	3.2-9.5 mm (0.125 - 0.375 in.)	12.7 mm (0.50 in.)	7.6 mm (0.3 in.)	7.6 mm (0.3 in.)
J-Frame	7.9 mm (0.3125 in.)	3.2-5 mm (0.125 - 0.375 in.)	12.7-1.1 mm (0.50-0.75 in.)	15.9 mm (0.625 in.)	9.5 mm (0.375 in.)
L-Frame	10 mm (0.4 in.)	3-10 mm (0.11 - 0.39 in.)	32 mm (1.35 in)	13 mm (0.51 in.)	16 mm (0.64 in.)

Voltage takeoff (control wire terminals) for mechanical lugs and terminal nuts

Description	Frame
Mechanical lug	
Control wire terminal for H-Frame lugs	HD/HG/HJ
Control wire terminal for J-Frame lugs	JD/JG/JJ/JL
Busbar connection	
Control wire terminal for H-Frame nut	HD/HG/HJ
Control wire terminal for J-Frame nut	JD/JG/JJ/JL
Control tape takeoff	L-Frame

Insulation of live parts

DB413127.eps
Phase barrier or terminal shield extension past end of circuit breaker **B** see table

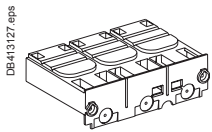
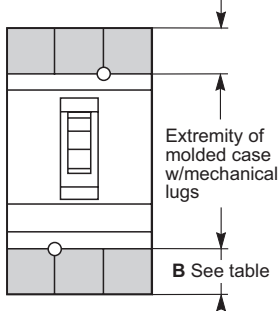

H-Frame short lug shield.

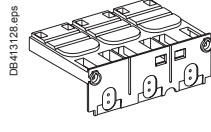

J-Frame short lug shield.

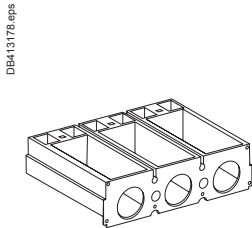

L-Frame short lug shield.

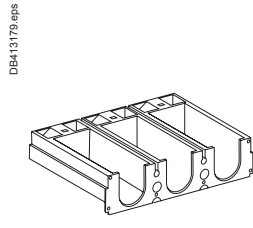

L-Frame short compression connector shield.

Terminal shields and phase barriers

Used with	Description	Dimension B		Qty per kit		
		inch	mm			
H- and J-Frame mechanical lugs	Short lug shield	Frame	Max. wire size			
		H-Frame 60 A	3 AWG	0.50	12.7	1
		H-Frame 150 A	3/0 AWG	0.50	12.7	1
		J-Frame	350 kcmil	0.24	6.1	1
H- and J-Frame power distribution connectors and compression lugs	Long lug shield	H-Frame long lug shield		2.24	56.9	1
		J-Frame long lug shield		1.68	42.7	1
L-Frame		Terminal shield (3P)		-		1

Accessories and auxiliaries

Selection of auxiliaries for PowerPact 150 / 250 A H-Frame and J-Frame

Standard

All PowerPact Multistandard circuit breakers and automatic switches have slots for the electrical auxiliaries.

4 indication contacts

- 2 ON/OFF (OF1 and OF2)
- 1 trip indication (SD)
- 1 fault-trip indication (SDE)

1 remote-tripping release

- either 1 MN undervoltage release
- or 1 MX shunt trip.

Remote indications

Circuit breakers equipped with Micrologic trip units may be equipped with a fault-trip indication to identify the type of fault by installing:

1 indication module with two outputs (see page A-56)

- either an SDx module with Micrologic 3.x / 5 E
- This module occupies the slots of one OF contact and an MN/MX release.

All these auxiliaries may be installed with a motor operator.

The following table indicates auxiliary possibilities depending on the type of trip unit.

Micrologic 3

Standard auxiliary possibilities based on trip unit

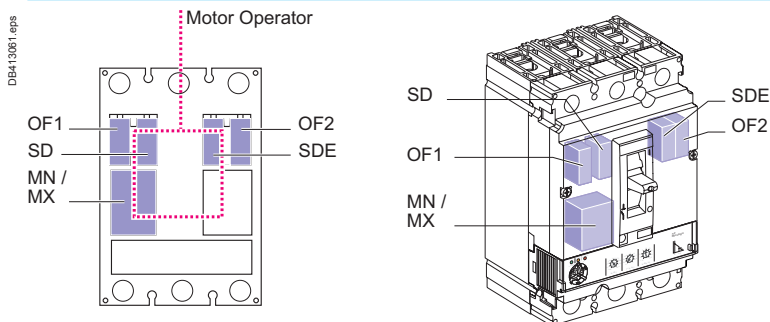

Micrologic 5

Standard auxiliary possibilities based on trip unit

Remote indications via SDx

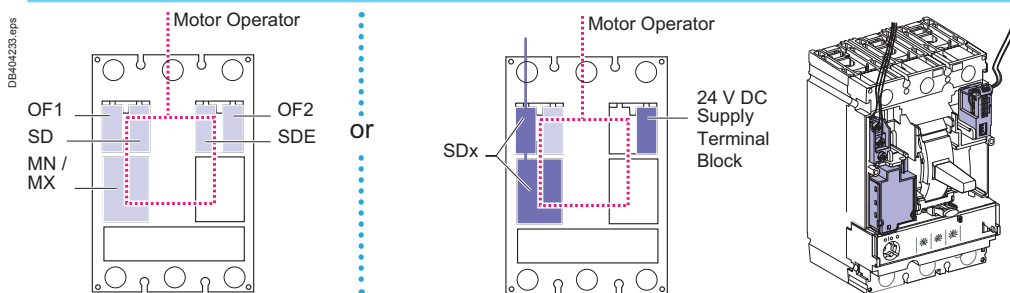

The SDx uses the OF1 and MN/MX slots.

External connection is made via a terminal block in the OF1 slot.

The 24 V DC supply provides for the Micrologic 5 display when the device is OFF or under low-load conditions.

Selection of auxiliaries for PowerPact 150 / 250 A H-Frame and J-Frame

Communication network

- Communication networks require specific auxiliaries.
- Communication of status indications:
 - 1 BSCM module
 - 1 NSX cord (internal terminal block) for both communication and 24 V DC supply to the BSCM.
- Communication of status conditions is compatible with a standard motor operator.
- Communication of status indications and controls requires, in addition to the previous auxiliaries:
 - 1 communicating motor operator connected to the BSCM.
- Communication of measurements is available on Micrologic 5. The system consists of:
 - 1 NSX cord (internal terminal block) for both communication and 24 V DC supply to the Micrologic.
- Communication of measurements is compatible with a standard or communicating motor operator.
- Communication of status indications, controls and measurements is available on Micrologic 5. The system consists of:
 - 1 BSCM module
 - 1 NSX cord (internal terminal block) for both communication and 24 V DC supply to the BSCM and the Micrologic
 - 1 communicating motor operator connected to the BSCM.
- Installation of SDx is compatible with communication network.

Micrologic 3

Communication network auxiliary possibilities based on trip unit

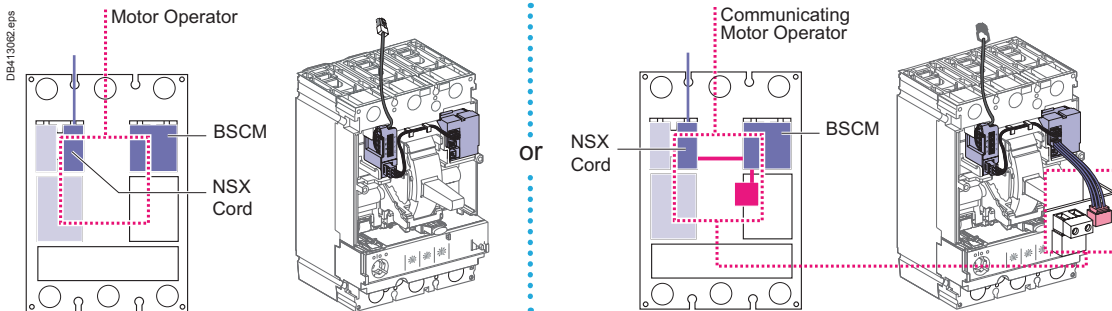

Micrologic 5

Communication of measurements with or without FDM121 display

Communication of status indications, controls and measurements with or without FDM121 display

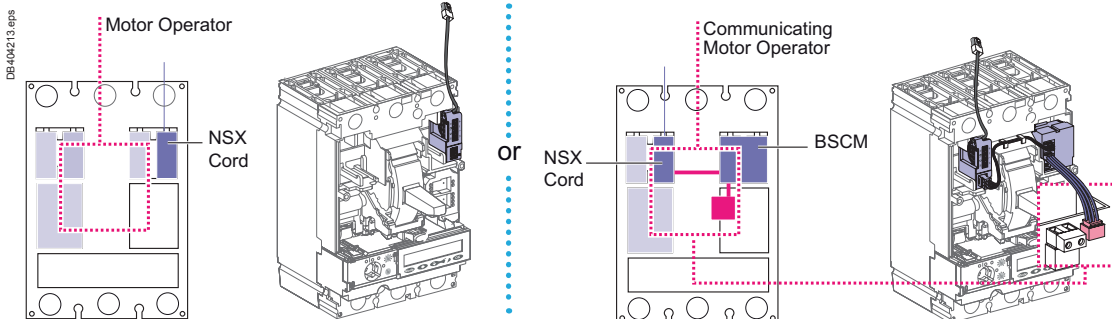

Accessories and auxiliaries

Selection of auxiliaries for PowerPact 400 / 600 A L-Frame

Standard

All PowerPact Multistandard circuit breakers and automatic switches have slots for the electrical auxiliaries.

5 indication contacts

- 3 ON/OFF (OF1, OF2 and OF3)
- 1 trip indication (SD)
- 1 fault-trip indication (SDE)

1 remote-tripping release

- either 1 MN undervoltage release
- or 1 MX shunt trip.

Remote indications

Circuit breakers equipped with Micrologic trip units may be equipped with a fault-trip indication to identify the type of fault by installing:

1 indication module with two outputs (see page A-56)

- either an SDx module with Micrologic 3.x / 5 E
- This module occupies the slots of one OF contact and an MN/MX release.

All these auxiliaries may be installed with a motor operator.

The following table indicates auxiliary possibilities depending on the type of trip unit.

Micrologic 3

Standard auxiliary possibilities based on trip unit

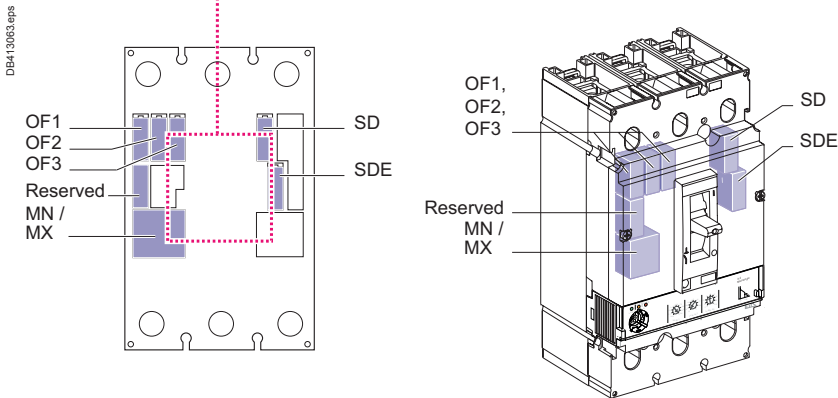

Micrologic 5

Standard auxiliary possibilities based on trip unit

Remote indications via SDx

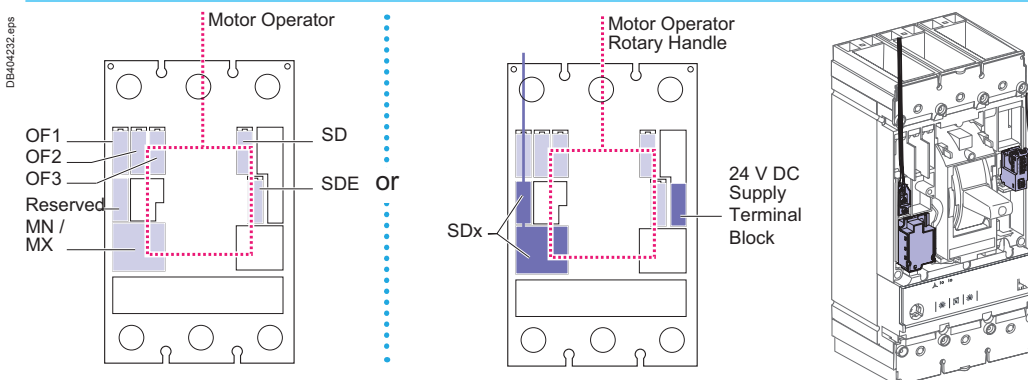

External connection is made via using a terminal block in the reserved slot. The 24 V DC supply provides for the Micrologic 5 display when the device is OFF or under low-load conditions.

Selection of auxiliaries for PowerPact 400 / 600 A L-Frame

Communication network

- Communication networks require specific auxiliaries.
- Communication of status indications:
 - 1 BSCM module
 - 1 NSX cord (internal terminal block) for both communication and 24 V DC supply to the BSCM.
- Communication of status conditions is compatible with a standard motor operator.
- Communication of status indications and controls requires, in addition to the previous auxiliaries:
 - 1 communicating motor operator connected to the BSCM.
- Communication of measurements is available on Micrologic 5. The system consists of:
 - 1 NSX cord (internal terminal block) for both communication and 24 V DC supply to the Micrologic.
- Communication of measurements is compatible with a standard or communicating motor operator.
- Communication of status indications, controls and measurements is available on Micrologic 5. The system consists of:
 - 1 BSCM module
 - 1 NSX cord (internal terminal block) for both communication and 24 V DC supply to the BSCM and the Micrologic
 - 1 communicating motor operator connected to the BSCM.
- Installation of SDx is compatible with communication network.

Micrologic 3

Communication network auxiliary possibilities based on trip unit

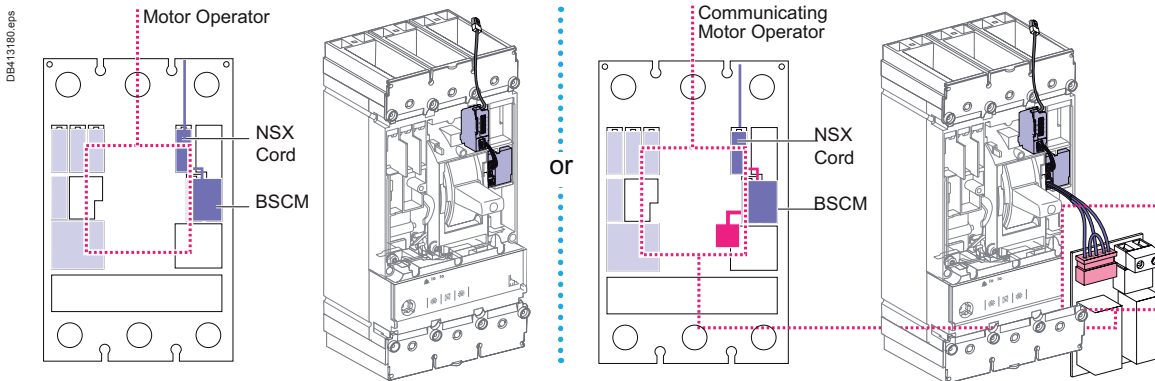

Micrologic 5

Communication of status indication

Communication of status indications, controls and measurements with or without FDM121 display

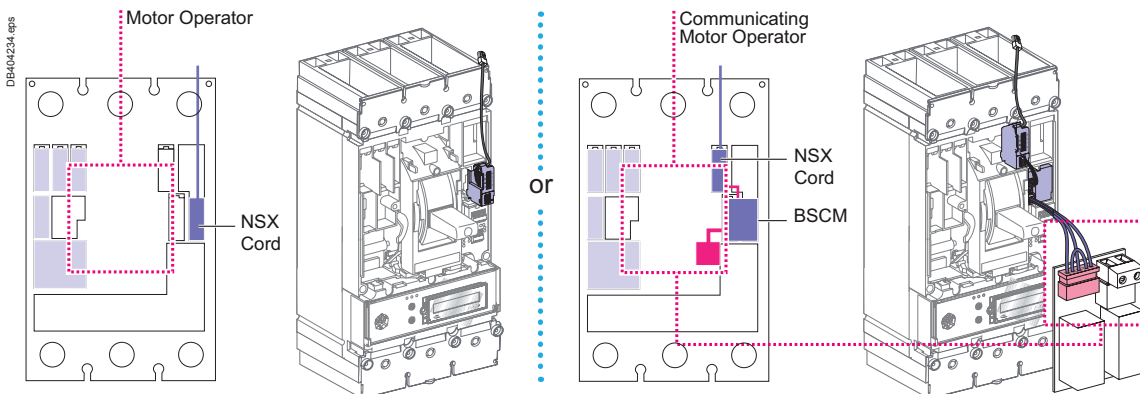

DB4136B.eps



Auxiliary Switch (OF) /
Alarm Switch (SD).

DB4131E2.eps

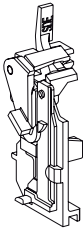

Overcurrent Trip Switch
Actuator (SDE).

Accessory connections

Electrical accessories are fitted with numbered terminal blocks for wires with the following maximum size:

- 1.5 mm² (16 AWG) for auxiliary switches (OF1 or OF2), and shunt trip (MX) or undervoltage trip (MN)
- 2.5 mm² (14 AWG) for the motor operator.

Auxiliary switch wiring exits fixed mounted devices through a knock-out in the front cover.

Auxiliary and alarm indication contacts

Auxiliary indication contacts provide remote information of the circuit breaker status and can thus be used for indications, electrical locking, relays, etc.

Auxiliary and alarm indication contacts

Applications Open/Closed-Auxiliary switches (OF)

- Indicates the position of the circuit breaker contacts.

Trip indication-alarm switch (SD)

- Indicates that the circuit breaker has tripped due to an overload, short circuit or ground fault, the operation of a shunt trip or undervoltage trip or the “push-to-trip” button.

- Resets when the circuit breaker is reset.

Overcurrent trip switch (SDE)

- Indicates that the circuit breaker has tripped due to an overload, short circuit or ground fault.

- Resets when the circuit breaker is reset.

- The above switches are also available in low-level versions (with gold flash plating) capable of switching very low loads (e.g., for controlling PLCs or electronic circuits).

Rotary Handle Indicator: CAO (early-break) and CAF (early-make)

- Fitted in the rotary handle module (see page A-59).

Installation and connection

- The auxiliary switch (OF), alarm switch (SD), and overcurrent trip switch (SDE) indication contacts snap into cavities behind the front accessory cover of the circuit breaker.

- One model serves for all indication functions depending on where it is fitted in the circuit breaker.

- The overcurrent trip switch (SDE) in a circuit breaker equipped with a thermal-magnetic trip unit requires the SDE actuator.

Standards

- The internal accessories comply with requirements of Underwriters Laboratories® Inc. (UL®).

- UL 489 and Canadian Standard Association C22.2 No. 5-02 Standards.

- All internal accessories are Listed for field installation per UL file E103955 and Certified under CSA file LR 69561.

- Auxiliary indicator contacts comply with UL 489, CSA C22.2

No. 5-02 and IEC 60947-5 Standards. “Low-level” indicator contacts are not UL Recognized.

Note: see page A-65 for drawout options.

Electrical characteristics of auxiliary contacts

Contacts		Standard				Low level			
Types of contacts		All				OF, SD, SDE, SDV			
Rated thermal current (A)		6				5			
Minimum load		100 mA at 24 V DC				1 mA at 4 V DC			
Utilisation cat. (IEC 60947-5-1)		AC12	AC15	DC12	DC14	AC12	AC15	DC12	DC14
Operational current (A)	24 V AC/DC	6	6	6	1	5	3	5	1
	48 V AC/DC	6	6	2.5	0.2	5	3	2.5	0.2
	110 V AC/DC	6	5	0.6	0.05	5	2.5	0.6	0.05
	220/240 V AC	6	4	-	-	5	2	-	-
	250 V DC	-	-	0.3	0.03	5	-	0.3	0.03
	380/440 V AC	6	2	-	-	5	1.5	-	-
	480 V AC	6	1.5	-	-	5	1	-	-
660/690 V AC	6	0.1	-	-	-	-	-	-	

SDx is a relay module with two outputs. It send different signals depending on the type of fault. It may not be used together.

PG 103377 eps



SDx module with terminal block.

SDx module

The SDx module remotely monitors the trip or alarm conditions of PowerPact Multistandard circuit breakers equipped with electronic protection.

An SDx relay module installed inside the circuit breaker can be used to remote the overload trip signal.

This module receives the signal from the Micrologic electronic trip unit through an optical link and makes it available on the terminal block. The signal is cleared when the circuit breaker is closed.

These outputs can be reprogrammed to be assigned to other types of tripping or alarm (see page A-56).

The SDx module may be used in 400 Hz systems for voltages from 24 to 440 V.

The SD2 output, available on all Micrologic trip units, corresponds to the overload-trip indication.

The SD4 output, available on Micrologic 5, is assigned to:

- overload pre-alarm (Micrologic 5)

These two outputs automatically reset when the device is closed (turned ON).

For Micrologic 5, the SD2 and SD4 outputs can be reprogrammed to be assigned to other types of tripping or alarm.

It is possible to assign a function output characteristics:

- latching with a time delay. Return to the initial state occurs at the end of the time delay

- permanent latching. Return to the initial state takes place through the communication function.

Static outputs: 24 - 415 V AC / V DC; 80 mA max.

Output characteristics

Output reset can be:

- manual by a pushbutton included in the wiring diagram
- automatic after an adjustable time delay (1 to 15 minutes) to take into account the motor-cooling time.

Static outputs: 24 - 415 V AC / V DC; 80 mA max. a (+) 24 - 415 V.

044313_20_SE eps



MX or MN voltage release.

Shunt trip (MX) and undervoltage trip (MN)

A voltage release can be used to trip the circuit breaker using a control signal.

Applications shunt trip (MX)

- Trips the circuit breaker when the control voltage rises above 70 % of its rated voltage.
- Impulse type ≥ 20 ms or maintained control signals.
- AC shunt trips are suitable for ground-fault protection when combined with a Class I ground-fault sensing element.
- Continuous duty rated coil.

Undervoltage trip (MN)

- Trips the circuit breaker when the control voltage drops below a tripping threshold.
- Drops out between 35 % and 70 % of the rated voltage.
- Continuous duty rated coil.
- Circuit breaker closing is possible only if the voltage exceeds 85 % of the rated voltage. If an undervoltage condition exists, operation of the closing mechanism of the circuit breaker will not permit the main contacts to touch, even momentarily. This is commonly called "Kiss Free".

Installation and connection

- Accessories are common to H-, J-, and L-frame circuit breakers and snap into cavities under the front accessory cover of the circuit breaker.
- Each terminal may be connected by one 1.0 - 2.5 mm² (18 - 14 AWG) stranded copper wire.

Standards

- The circuit breaker must be reset locally after being tripped by shunt trip (MX) or undervoltage trip (MN).
- Tripping by the shunt trip or undervoltage trip has priority over manual (or motor operator) closing; in the presence of a standing trip order such an action does not result in any closing, even temporarily, of the main contacts.
- Endurance: 50 % of the rated mechanical endurance of the circuit breaker.

Characteristics		AC	DC
Rated voltage (V)		24, 48, 120, 208/277, 380/480, 525, 600	12, 24, 30, 48, 60, 125, 250
Power requirements	Pickup (shunt trip)	< 10 VA	< 5 W
	Seal-in (undervoltage trip)	< 5 VA	< 5 W
Clearing time (ms)		< 50	< 50

Rotary handles

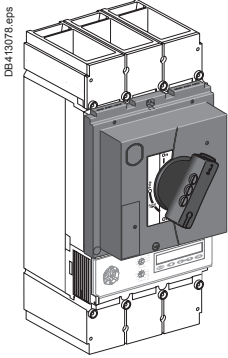

Directly mounted rotary operating handle.

Direct rotary handles

Installation

The directly mounted rotary operating handle replaces the circuit breaker front accessory cover (secured by screws).

Operation

The direct rotary handle maintains:

- suitability for isolation
- indication of three positions: I (ON), Tripped and O (OFF)
- access to the “push-to-trip” button
- visibility of, and access to, trip unit settings
- the circuit breaker may be locked in the OFF position by using one to three padlocks (not supplied).

Models

- Standard with black handle.
- VDE type with red handle and yellow bezel for machine tool control.

Variations

Accessories transform the standard direct rotary handle for the following situations:

- motor control centers (MCCs):
 - opening of door prevented when circuit breaker is on
 - closing of circuit breaker inhibited when door is open
- machine tool control; complies with CNOMO E03.81.501N; degree of protection IP54
- early make or early break contacts may be installed into direct mount rotary handle.

Standards

The directly-mounted rotary operating handle is UL Listed under file E103955 and CSA Certified under file LR 69561.

Extended rotary handle

Installation

The door-mounted (extended) rotary operating handle is made up of:

- a unit that replaces the front accessory cover of the circuit breaker (secured by screws)
- an assembly (handle and front plate) on the door that is always secured in the same position, whether the circuit breaker is installed vertically or horizontally
- an adjustable extension shaft
- the handle mechanism can be used in NEMA 3R and 12 enclosure applications.

Operation

The door mounted operating handle makes it possible to operate circuit breakers installed in enclosure from the front. The door mounted operating handle maintains:

- suitability for isolation
- indication of the three positions OFF (O), ON (I) and tripped
- visibility of and access to trip unit settings when the door is open
- degree of protection: IP40 as per IEC 529.

Defeatable interlock prevents opening of door when circuit breaker is on.

The circuit breaker may be locked in the off position by using one to three padlocks, padlock shackle diameter 5–8 mm (0.19–0.31 in.); padlocks are not supplied; locking prevents opening of the enclosure door.

Shaft length

The shaft length is the distance between the back of the circuit breaker and the door:

- minimum shaft length is 185 mm (7.4 in.)
- maximum shaft length is 600 mm (24 in.)
- extended shaft length must be adjusted.

Models

- Standard with black handle.
- VDE type with red handle and yellow bezel for machine tool control.

Variations

For drawout configurations, the extended rotary handle is also available with a telescopic shaft containing two stable positions.

Standards

The door-mounted rotary operating handle is UL Listed under file E103955 and CSA Certified under file LR 69561.

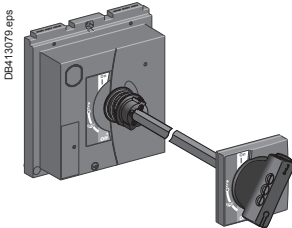

Door mounted rotary operating handle.

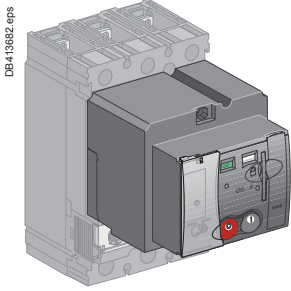

PowerPact with motor mechanism.

When equipped with a **motor-mechanism** module, PowerPact circuit breakers feature very high mechanical endurance as well as easy and sure operation:

- all circuit-breaker indications and information remain visible and accessible, including trip-unit settings and indications
- suitability for isolation is maintained and padlocking remains possible
- double insulation of the front face.

A specific motor mechanism is required for operation via the communication function. This **communicating motor mechanism** must be connected to the BSCM module to receive the opening and closing orders. Operation is identical to that of a standard motor mechanism.

Applications

- Local motor-driven operation, centralised operation, automatic distribution control.
- Normal/standby source changeover or switching to a replacement source to ensure availability or optimise energy costs.
- Load shedding and reconnection.
- Synchrocoupling.

Operation

The type of operation is selected using the manual/auto mode selection switch (7). A transparent, lead-seal cover controls access to the switch.

Automatic

When the switch is in the "auto" position, the ON/OFF (I/O) buttons and the charging lever on the mechanism are locked.

- Circuit-breaker ON and OFF controlled by two impulse-type or maintained signals.
- Automatic spring charging following voluntary tripping (by MN or MX), with standard wiring.
- Mandatory manual reset following tripping due to an electrical fault.

Manual

When the switch is in the "manual" position, the ON/OFF (I/O) buttons may be used. A microswitch linked to the manual position can remote the information.

- Circuit-breaker ON and OFF controlled by 2 pushbuttons I/O.
- Recharging of stored-energy system by pumping the lever 8 times.
- Padlocking in OFF position.

Installation and connections

All installation (fixed, plug-in/withdrawable) and connection possibilities are maintained.

Motor-mechanism module connections are made behind its front cover to integrated terminals, for cables up to 2.5 mm².

Optional accessories

- Keylock for locking in OFF position.
- Operations counter for the Powerpact L-frame, indicating the number of ON/OFF cycles. Must be installed on the front of the motor-mechanism module.

Characteristics

Motor mechanism		MT100 to MT630	
Response time (ms)	opening	< 600	
	closing	< 80	
Operating frequency	cycles/minute max.	4	
Control voltage (V)	DC	24/30 - 48/60 - 110/130 - 250	
	AC 50/60 Hz	48 (50 Hz) - 110/130 - 220/240 - 380/440	
Consumption	DC (W)	opening	≤ 500
		closing	≤ 500
	AC (VA)	opening	≤ 500
		closing	≤ 500

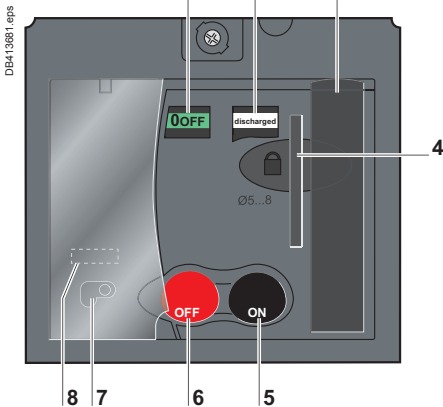

- 1 Position indicator (positive contact indication)
- 2 Spring status indicator (charged, discharged)
- 3 Manual spring-charging lever
- 4 Keylock device (optional)
Locking device (OFF position), using 1 to 3 padlocks, shackle diameter 5 to 8 mm, not supplied
- 5 I (ON) pushbutton
- 6 O (OFF) pushbutton
- 7 Manual/auto mode selection switch. The position of this switch can be indicated remotely.
- 8 Operation counter (Powerpact L-frame)

Locks

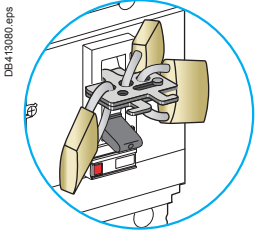

Toggle locking using padlocks and an accessory:
Removable device

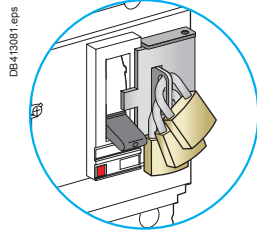

Fixed device attached to the case.

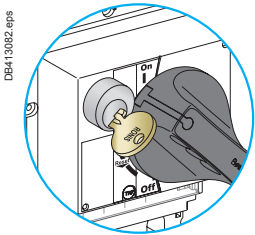

Rotary-handle locking using a keylock.

Padlocking systems can receive up to three padlocks with diameters of 5-8 mm (0.19-0.31 in.); padlocks not supplied.

Device	Description
Handle padlocking device ⁽¹⁾	Removable (lock OFF only)
	Fixed (lock OFF or ON)
	Fixed (lock OFF only)
Interlocking (not UL listed)	Mechanical for circuit breakers with rotary handles
	Mechanical for circuit breakers with toggles
Key locking	Provision and 2 locks keyed alike Ronis and Profalux

⁽¹⁾ Rotary handle has integral padlocking capability.

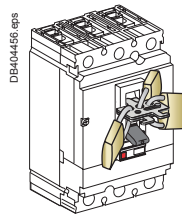

Removable attachment.

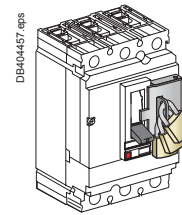

Fixed padlock attachment.

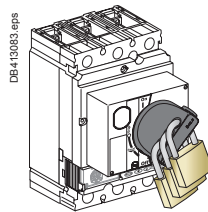

Rotary-handle locking using a padlock or a keylock.

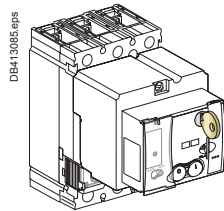
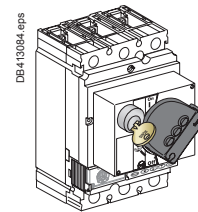

Motor-mechanism locking using a padlock or a keylock.

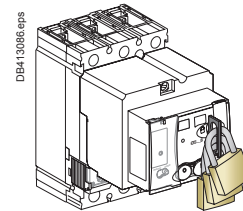

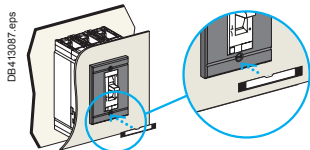

Identification accessories.

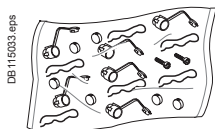

Sealing accessories.

Outgoing-circuit identification

Powerpact H- J- and L-frame can be equipped with label holders supplied in sets of ten (cat. no. LV429226). They are compatible with escutcheons.

Sealing accessories

Sealing accessories are available. Each bag of accessories contains all the parts required for the types of sealing indicated below.

A bag contains:

- 6 sealing accessories
- 6 lead seals
- 0.5 m of wire
- 2 screws.

Types of seals and corresponding functions

Toggle control	 DB413088 eps	 DB413089 eps	
Rotary handle	 DB413090 eps	 DB413091 eps	
Motor mechanism	 DB413092 eps	 DB413093 eps	 DB413094 eps
Types of seals	Front-cover fixing screw	Trip-unit transparent cover	Motor-mechanism transparent cover
Protected operations	<ul style="list-style-type: none"> ■ front removal ■ access to auxiliaries ■ trip-unit removal. 	<ul style="list-style-type: none"> ■ modification of settings ■ access to test connector. 	<ul style="list-style-type: none"> ■ access to manual/auto mode selection switch: depending on its position, manual ⁽¹⁾ or automatic operation is not possible. <p><i>(1) In this case, local operation is not possible.</i></p>

For unit-mount or plug-in installation

- Front-panel escutcheons for toggle handles secures to the panel from the front.

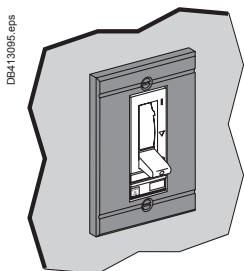

Distribution system

Plates for mounting on 60 mm busbar

Description

The PowerPact mounting plate system for busbars simplifies the installation of components used in your electrical installations. Power distribution is performed by a busbar.

The mounting plates are fitted directly on this busbar, by snap-on mounting, thus implementing electrical connection.

This system offers numerous benefits:

- space saving in switchboards
- fast, safe and reliable electrical and mechanical connection
- easy connection
- protection for users against electric shocks by direct contacts (IP20) by using covers
- equipment flexibility and modularity
- increased equipment availability: easier maintenance
- power supply without drilling (connectors) from 1.5 to 120 mm².

The 3P busbar

The busbar interaxis is 60 mm. Depending on the cross section of the bars, the busbar can withstand a maximum current of 630 A.

Note: the bars forming the busbar are not part of the PowerPact offer. They are not supplied by us. Their selection depends on the maximum current needed for your installation (see next page).

Support for 3P busbar (1)

For applications having to comply with the IEC standard, use the LA9ZX01495 support.

The mounting plates (2)

These allow mounting of the power feeder components consisting of:

- PowerPact 100-250 A
- PowerPact 250 and 400-630 A.

Accessories

Accessories complete the offer:

- covers (3) for 5 and 10 mm bars
- end covers (4)
- a base plate (5)
- 1P connectors (6), 3P connectors on mounting plate
- a spring terminal 3P connection module.

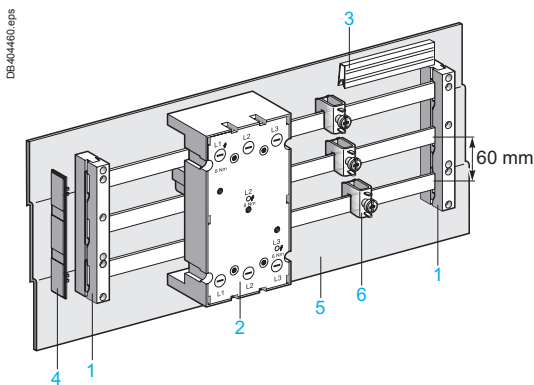

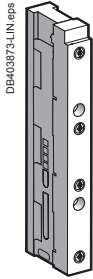

LA9ZX01495

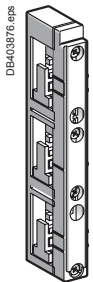

LA9ZX01508

General characteristics										
		LA9ZX01495 (IEC)								
Bar dimensions compatibility	mm	12 x 5	15 x 5	20 x 5	25 x 5	30 x 5	12 x 10	20 x 10	30 x 10	
Max. rated operating current	A	200	250	320	400	450	360	520	630	
Min. peak permissible rated current	kA	30	30	30	30	45	35	35	53	
Distance max. between 2 busbars supports	mm	570	570	570	570	570	570	570	570	
Degree of protection	IP	20 (with cover LA9ZX01244 or LA9ZX01245)								
Thermal resistance	°C	125								
Rated current frequency	Hz	50/60								
Rated insulation voltage	V	690								
Rated operating voltage	V	690								
		LA9ZX01508 (UL)								
Bar dimensions compatibility	mm	12 x 5	20 x 5	30 x 5	12 x 10	20 x 10	30 x 10			
Rated operating current	A	150	362	500	300	564	630			
I_{eff} (RMS) surge current	kA	18	18	22 - 25	18	18	22 - 25			
SCCR (protected by Compact NSX circuit breaker)	250 A 480 V AC 250 A 600 V AC 400 A 480 V AC 400 A 600 V AC 500 A 480 V AC 600 A 600 V AC 600 A 480 V AC 600 A 600 V AC	kA	65 25 - 35 - - - -	- - 65 - - - - -	- - 65 35 65 - 50 25	65 25 - - - - - -	- - 65 35 - - - -	- - 65 35 65 - 50 25		
SCCR (protected by fuses Class J or T ...)	400 A 480 V AC 500 A 480 V AC 500 A 600 V AC	kA	100 - -	100 - -	100 100 100	100 - -	100 - -	100 100 100		
Distance max. between 2 busbars supports (busbar protected)	mm	400	800	800	400	800	800			
Degree of protection	IP	20 (with cover LA9ZX01244 or LA9ZX01245)								
Thermal resistance	°C	125								
Rated current frequency	Hz	50/60								
Rated operating voltage	V	600								

Choice of mounting plates

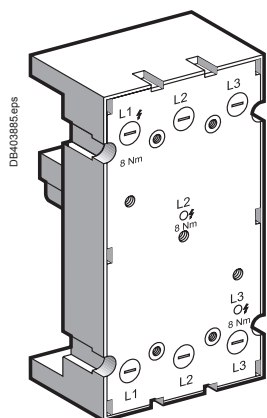

LA9ZA32600

Characteristics of busbar mounting plates

Type of mounting plate	LA9ZA32600	
Degree of protection as per IEC 60529	IP	20
Rated insulation voltage	V	690
Permissible current	A	25
		100-250
		400-630
Peak rated current	kA	50
SCCR (UL) with Compact NSX circuit breaker protection	mm ²	The reinforced breaking capacity due to cascading in circuit breaker combination is maintained

<i>Functions and characteristics</i>	A-1
Operating conditions	B-2
<hr/>	
Installation in equipment	
Power supply and weights	B-3
Safety clearances and minimum distances	B-4
Installation example	B-5
<hr/>	
Control wiring	B-6
<hr/>	
Temperature derating	B-8
<i>Dimensions</i>	C-1
<i>Wiring diagrams</i>	D-1
<i>Additional characteristics</i>	E-1
<i>Catalogue numbers</i>	F-1
<i>Glossary</i>	G-1

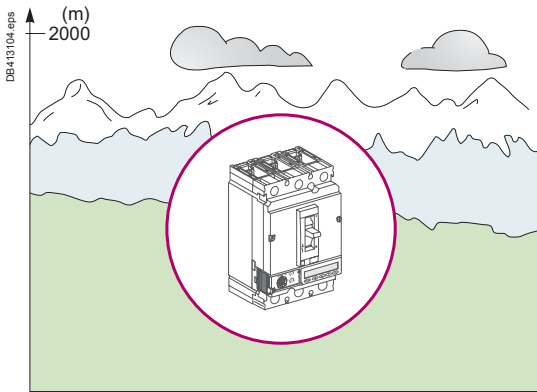

Altitude derating

Altitude does not significantly affect the characteristics of PowerPact Multistandard circuit breakers up to 6560 ft (2000 m). Above this altitude, it is necessary to take into account the decrease in the dielectric strength and cooling capacity of air.

The following table gives the corrections to be applied for altitudes above 6560 ft (2000 m).

The breaking capacities remain unchanged.

Altitude (m)		2000 (6560 ft)	3000 (9840 ft)	4000 (13120 ft)	5000 (16400 ft)
Dielectric withstand voltage		3000 V	2500 V	2100 V	1800 V
Insulation voltage	V_i	800 V	700 V	600 V	500 V
Maximum operational voltage	V_e	690 V	590 V	520 V	460 V
Average current capacity (A) at 40 °C (104 °F)	$I_n \times$	1.0	0.96	0.93	0.9

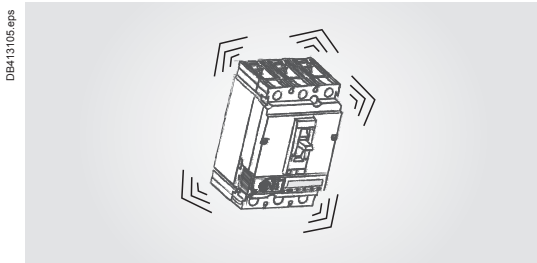

Vibrations

PowerPact Multistandard devices resist mechanical vibration.

Tests are carried out in compliance with standard UL489 SA and SB for the levels required by merchant-marine inspection organizations (Veritas, Lloyd's, etc.):

PowerPact™ Multistandard circuit breaker meet IEC 60068-2-6 for vibration:

- 2.0 to 25.0 Hz and amplitude ± 1.6 mm
- 25.0 to 100 Hz acceleration ± 4.0 g.

PowerPact L-frame circuit breaker meet IEC 60068-2-6 for vibration:

- 2.0 to 13.2 Hz and amplitude 0.039 in. (1 mm)
- 13.2 to 100 Hz constant acceleration.

Excessive vibration may cause tripping, breaks in connections or damage to mechanical parts.

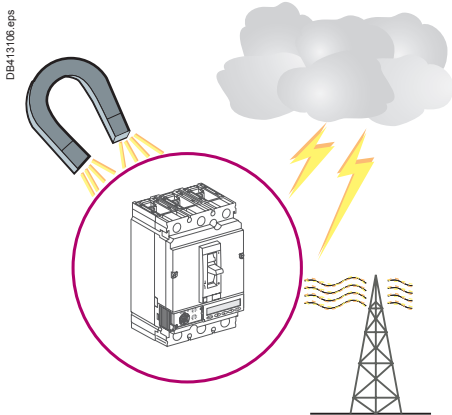

Electromagnetic disturbances

PowerPact Multistandard devices are protected against:

- overvoltages caused by circuit switching
- overvoltages caused by an atmospheric disturbances or by a distribution-system outage (such as from failure due to lightning)
- devices emitting radio waves (radios, walkie-talkies, radar, etc.)
- electrostatic discharges produced directly by users.

PowerPact Multistandard devices have successfully passed the electromagnetic-compatibility tests (EMC) defined by the following international standards:

- IEC/EN 60947-2: Low-voltage switchgear and controlgear, part 2: circuit breakers:
 - annex F: Immunity tests for circuit breakers with electronic protection
 - annex B: Immunity tests for residual current protection
- IEC/EN 61000-4-2: Electrostatic-discharge immunity tests
- IEC/EN 61000-4-3: Radiated, radio-frequency, electromagnetic-field immunity tests
- IEC/EN 61000-4-4: Electrical fast transient/burst immunity tests
- IEC/EN 61000-4-5: Surge immunity tests
- IEC/EN 61000-4-6: Immunity tests for conducted disturbances induced by radiofrequency fields
- CISPR 11: Limits and methods of measurement of electromagnetic disturbance characteristics of industrial, scientific and medical (ISM) radio-frequency equipment.

These tests ensure that:

- no nuisance tripping occurs
- tripping times are respected

Tropicalization

The materials used in PowerPact Multistandard circuit breakers will not support the growth of fungus and mold.

PowerPact circuit breakers have passed the test defined below for extreme atmospheric conditions.

Dry cold and dry heat:

- IEC 68-2-1-dry cold at -55 °C
- IEC 68-2-2-dry heat at $+85$ °C.

Damp heat (tropicalization)

- IEC 68-2-30-damp heat (temperature $+55$ °C and relative humidity of 95 %).
- IEC 68-2-52 level 2 - salt mist.

Installation in equipment

Power supply and weights

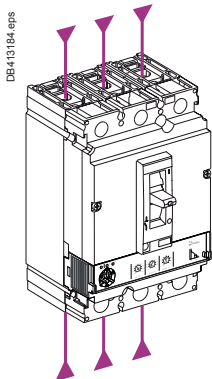

Power from the top or bottom

PowerPact Multistandard circuit breakers with factory-sealed trip units can be supplied from either the top or the bottom without any reduction in performance. This capability facilitates connection when installed in end-use equipment.

All connection and insulation accessories can be used on circuit breakers supplied either from the top or bottom.

Weight

The table below presents the weights of the circuit breakers and the main accessories, which must be summed to obtain the total weight. The values are valid for all performance categories.

Type of device		Circuit breakers	Base	Cradle	Motor operator
H-frame, 100 A	3P	2.05 kg (4.52 lb)	0.8 kg (1.75 lb)	2.2 kg (4.85 lb)	1.2 kg (2.65 lb)
H-frame, 150 A	3P	2.2 kg (4.85 lb)	0.8 kg (1.75 lb)	2.2 kg (4.85 lb)	1.2 kg (2.65 lb)
J-frame, 250 A	3P	2.4 kg (5.29 lb)	0.8 kg (1.75 lb)	2.2 kg (4.85 lb)	1.2 kg (2.65 lb)
L-frame, 600 A	3P	6.19 kg (13.65 lb)	2.4 kg (5.29 lb)	2.2 kg (4.85 lb)	2.8 kg (6.17 lb)

Installation in equipment

Safety clearances and minimum distances

General rules

When installing a circuit breaker, minimum distances (safety clearances) must be maintained between the device and panels, bars and other protection devices installed nearby. These distances, which depend on the voltage, are defined by tests carried out in accordance with UL standards.

If installation is not checked by type tests, it is also necessary to:

- use insulated bars for circuit-breaker connections
- segregate the busbars using phase barriers.

For PowerPact Multistandard devices, terminal shields and interphase barriers are recommended and may be mandatory depending on the operating voltage of the device and type of installation (unit-mount, drawout, etc.).

Power connections

The table below indicates the connection requirements for PowerPact Multistandard devices to ensure insulation of live parts for the various types of connection.

- Unit-mount devices with front connection (FC) or rear connection (RC).
- Plug-in or drawout devices.

Connection accessories such as crimp lugs, terminal extensions (straight, right-angle, double-L and 45°) and spreaders are supplied with interphase barriers. Long terminal shields provide a degree of protection of IP40 (ingress).

Installation example

Safety clearance

H- and J-Frame safety clearances

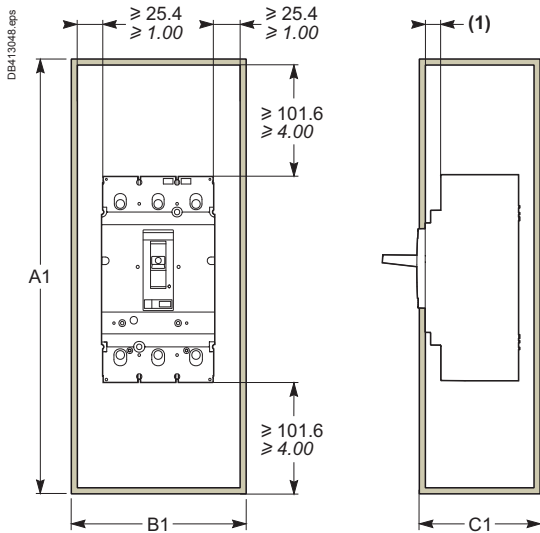

Fiber insulating plate

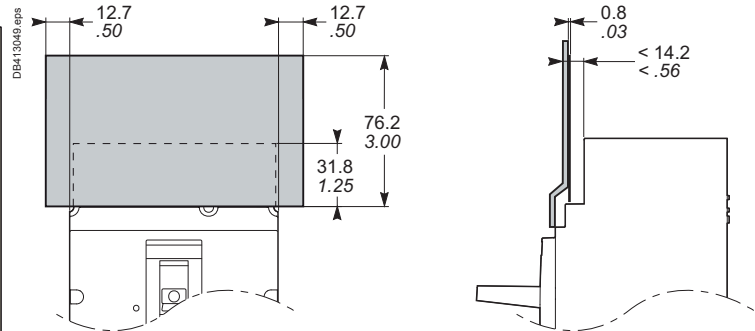

Enclosure dimensions



J-frame minimum enclosure insulation

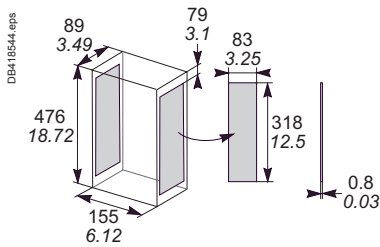

		Standard (80 %) rated	100 % rated
HD/HG/HJ/HL	15-150 A	396 x 155 x 89 mm 15.6 x 6.12 x 3.49 in.	396 x 155 x 89 mm 15.6 x 6.12 x 3.49 in.
HR		461 x 219 x 105 mm 18.13 x 8.63 x 4.13 in.	1575 x 572 x 356 mm 62 x 22.5 x 14 in.
JD/JG/JJ/JL ⁽²⁾	150-250 A	476 x 155 x 89 mm 18.72 x 6.12 x 3.49 in.	476 x 155 x 89 mm 18.72 x 6.12 x 3.49 in.
JR		724 x 314 x 137 mm 28.5 x 12.38 x 5.38 in.	1575 x 572 x 356 mm 62 x 22.5 x 14 in.
LD/LG/LL/LL	250-600 A	901 x 305 x 113 mm 35.48 x 12.00 x 4.45 in.	901 x 305 x 113 mm 35.48 x 12.00 x 4.45 in.
LR		1030 x 350 x 110 mm 40.5 x 13.75 x 4.33 in.	1030 x 350 x 110 mm 40.5 x 13.75 x 4.33 in.

(1) If dimension A < 0.56 in., attach fiber insulating plate, not provided, to enclosure cover.
 (2) Minimum enclosure insulation required if circuit breaker side < 4.13 in. (105 mm) from metal.

Recommended maximum cable lengths ⁽¹⁾

Power supply voltage (V DC)	12 V DC		24 V DC		48 V DC	
	1.5 mm ² (16 AWG)	2.5 mm ² (14 AWG)	1.5 mm ² (16 AWG)	2.5 mm ² (14 AWG)	1.5 mm ² (16 AWG)	2.5 mm ² (14 AWG)
Undervoltage trip (MN)	V source 100 %	15 m (49 ft)	-	160 m (525 ft)	-	640 m (2100 ft)
	V source 85 %	7 m (23 ft)	-	40 m (131 ft)	-	160 m (525 ft)
Shunt trip (MX)	V source 100 %	60 m (197 ft)	-	240 m (787 ft)	-	960 m (3150 ft)
	V source 85 %	30 m (98 ft)	-	120 m (394 ft)	-	480 m (1575 ft)
Motor operator	V source 100 %	-	-	10 m (33 ft)	16 m	65 m (213 ft)
	V source 85 %	-	-	2 m (6.6 ft)	4 m	17 m (56 ft)

(1) The indicated length is that of each of the two wires.

ULP connection system between Micrologic, FDM121 module and Modbus interface

The ULP (Universal Logic Plug) wiring system used by H-, J- and L-frame circuit breakers for connection through the Modbus network requires neither tools nor settings. The prefabricated cables are used for both data transfer and distribution of 24 V DC power. Connectors on each component are identified by ULP symbols, ensuring total compatibility between each component.

Available cords

All connections are made with prefabricated cords:

- NSX cord for connection of the internal terminal block to the Modbus interface or the FDM 121 display via an RJ45 connector. The cord is available in three lengths, 0.35 m, 1.3 m and 3 m
- ULP cords with RJ45 connectors at each end for the other connections between components. The cord is available in six lengths, 0.3 m, 0.6 m, 1 m, 2 m, 3 m and 5 m. For greater distances, two cords can be interconnected using the RJ45 female/female accessory.

Maximum length of 10 m between 2 modules and 30 m in all.

A line terminator must be fitted to all components with an unused RJ45 connector.

24 V DC power supply module

An external 24 V DC power supply is required for installations with communication networks, regardless of the type of trip unit.

On installations without communication networks, the power supply is available as an option for Micrologic 5 to:

- modify settings when the circuit breaker is open (OFF position)
- display measurements when the current flowing through the circuit breaker is low
- maintain the display of the cause of tripping.

To determine power requirements of devices, see [page A-44](#).

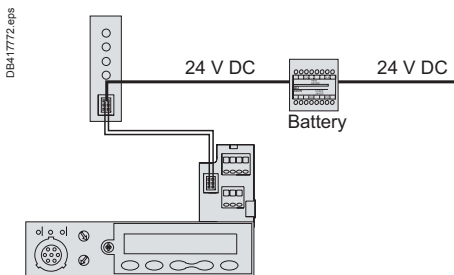
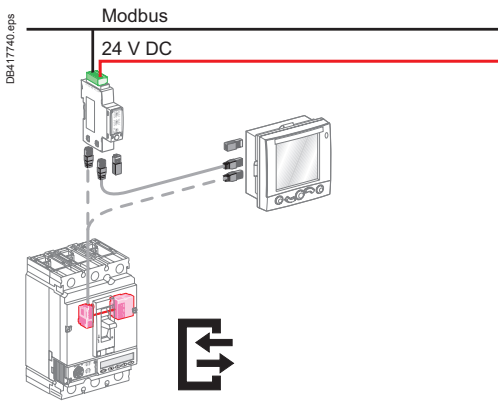

Power supply, without the communication function, using the terminal block with a backup battery.

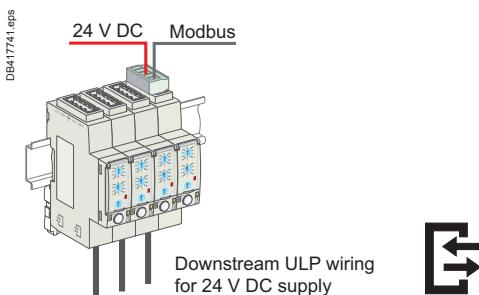

Power supply, without the communication function, using the Modbus interface.

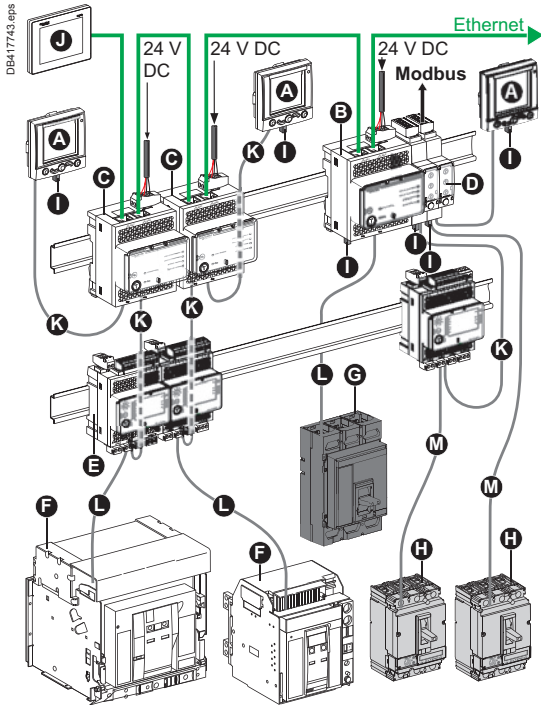

- A** FDM121 (TRV00121)
 - B** IFE master (LV434011)
 - C** IFE (LV434010)
 - D** IFM (TRV00210)
 - E** I/O application module (LV434063)
 - F** Masterpact NT/NW
 - G** Compact NS630b-3200
 - H** PowerPact
 - I** ULP termination (TRV00880)
 - J** FDM128 (LV434128)
 - K** ULP cable
 - L** Breaker ULP cord
 - M** NSX cord
- Ethernet
— Modbus

Wiring

Micrologic 5 without the communication function

The external 24 V DC supply is connected through the circuit breaker terminal block.

Use of a 24 V DC battery provides backup power for approximate 3 hours (100 mA) in the event of an interruption in the external supply.

Micrologic 5 with the communication function

The external 24 V DC supply is connected through the Modbus interface using a five-pin connector, including two for the power supply. Stacking accessories (see page 29) can be used to supply a number of interfaces by fast clip-on connection. The 24 V DC power is distributed downstream by the ULP (Universal Logic Plug) communication cables with RJ45 connectors. This system ensures both data transfer and power distribution to the connected modules.

Recommendations for 24 V DC wiring

- Do not connect the positive terminal to ground.
- Do not connect the negative terminal to ground.
- The maximum length for each conductor (\pm) is 10 m (33 ft).
- For connection distances greater than ten metres, the plus and minus conductors of the 24 V DC supply must be twisted to improve EMC.
- The 24 V DC conductors must cross the power cables perpendicularly. If this is difficult or impossible, the plus and minus conductors must be twisted.

Modbus

Each PowerPact Multistandard circuit breaker equipped with Micrologic 5 and an FDM121 display is connected to the Modbus network using the Modbus com module. Connection of all the circuit breakers and other Modbus devices in the equipment to a Modbus bus is made much easier by using a Modbus RJ45 junction block installed in the equipment.

Recommendations for Modbus wiring:

- the shielding may be grounded on one end only
- the conductors must be twisted to improve immunity (EMC)
- the Modbus conductors must cross the power cables perpendicularly.

Example

A unit-mount PowerPact L-frame circuit breaker equipped with a Micrologic can have a maximum I_r setting of:

- 400 A up to 50 °C (122 °F)
- 380 A up to 60 °C (140 °F).

Temperature derating

PowerPact equipped with thermal-magnetic trip units

PowerPact™ Multistandard circuit breakers may be used between -25 °C and +70 °C (-13°F and 158°F). For temperatures higher than 104°F (40 °C) inside the enclosure, devices must be derated.

Circuit breakers should be put into service under normal ambient, operating-temperature conditions.

The permissible storage-temperature range for PowerPact™ Multistandard circuit breakers in the original packing is -50 °C and +85 °C (-58°F ⁽¹⁾ and 185°F).

Temperature derating for H-Frame trip unit thermal protection-long-time

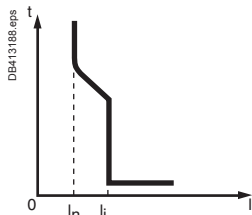

H-Frame trip curve

- (In) Fixed threshold thermal protection against overload.
- (Ii) Fixed threshold instantaneous protection against short circuits.

Temperature ⁽¹⁾		Rating (A) In															
°C	°F	60 to 150															
-10	14	23	30	38	46	53	60	68	76	88	103	112	123	137	160	180	221
0	32	21	28	36	43	49	56	63	71	83	97	107	117	131	151	171	207
10	50	20	26	33	40	46	52	59	66	77	90	101	111	126	141	161	194
20	68	18	24	31	37	42	48	54	62	72	84	96	105	120	132	152	180
30	86	17	22	28	34	39	44	50	56	66	77	88	98	110	121	139	165
40	104	15	20	25	30	35	40	45	50	60	70	80	90	100	110	125	150
50	122	12	17	21	25	30	34	38	43	53	62	72	80	86	95	109	131
60	140	9	14	17	20	24	28	31	35	46	53	63	70	72	80	93	111

⁽¹⁾ Shaded areas indicate temperature rerated values, non-shaded areas inside an enclosure are standard circuit breaker ampere ratings at 40 °C (104°F).

Temperature derating for J-Frame trip unit thermal protection-long-time

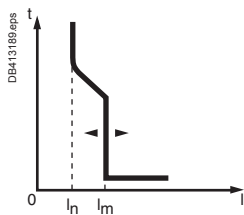

J-Frame trip unit

- (In) Fixed threshold thermal protection against overload.
- (Im) Adjustable instantaneous protection against short circuits.

Temperature ⁽¹⁾		Rating (A) In				
°C	°F	250				
-10	14	221	264	289	330	377
0	32	207	247	273	310	354
10	50	194	230	256	290	330
20	68	180	213	240	270	307
30	86	165	194	220	248	279
40	104	150	175	200	225	250
50	122	131	150	176	193	214
60	140	111	124	151	160	177

⁽¹⁾ Shaded areas indicate temperature rerated values, non-shaded areas inside an enclosure are standard circuit breaker ampere ratings at 40 °C (104°F).

PowerPact™ Multistandard circuit breakers equipped with electronic trip units.

Electronic trip units are not affected by variations in temperature. If the trip units are used in high-temperature environments, the Micrologic setting must nevertheless take into account the temperature limits of the circuit breaker.

Changes in temperature do not affect measurements by electronic trip units.

- The built-in CT sensors with Rogowski coils measure the current.
- The control electronics compare the value of the current to the settings defined for 40 °C (104°F).

Because temperature has no effect on the CT measurements, the tripping thresholds do not need to be modified.

However, the temperature rise caused by the flow of current combined with the ambient temperature increases the temperature of the device. To avoid reaching the thermal withstand value, it is necessary to limit the current flowing through the device, that is the maximum Ir setting as a function of the temperature.

The table below indicates the maximum long-time (LT) protection setting Ir (A) depending on the ambient temperature.

⁽¹⁾ -40 °F (-40 °C) for Micrologic trip units with an LCD screen.

PowerPact equipped with electronic trip units

Derating circuit breakers with Micrologic trip units

Type of device	Rating	Temperature						
		40 °C (104 °F)	45 °C (113 °F)	50 °C (122 °F)	55 °C (131 °F)	60 °C (140 °F)	65 °C (149 °F)	70 °C (158 °F)
H-Frame								
Unit-mount, plug-in or drawout	60 A	No derating						
	100 A	No derating						
	150 A	No derating						
J-Frame								
Unit-mount	250	250	250	250	245	237	230	225
Plug-in or drawout	250	250	245	237	230	225	220	215
L-Frame								
Unit-mount	400	400	400	400	390	380	370	360
Plug-in or drawout	400	400	390	380	370	360	350	340
Unit-mount	600	600	600	600	585	570	550	535
Plug-in or drawout	600	570	550	535	520	505	490	475

Example. A unit-mount PowerPact L-frame circuit breaker equipped with a Micrologic can have a maximum Ir setting of:

- 400 A up to 122 °F (50 °C)
- 380 A up to 140 °F (60 °C).

<i>Functions and characteristics</i>	A-1
<i>Installation recommendations</i>	B-1
PowerPact H-Frame circuit breakers	C-2
PowerPact J-Frame circuit breakers	C-4
PowerPact H- and J-Frame circuit breaker door cutouts	C-6
PowerPact L-Frame circuit breakers	C-8
PowerPact L-Frame circuit breaker handles and handle operators	C-11
PowerPact L-Frame circuit breaker connectors	C-15
Dimensions and mounting	
External modules	C-16
FDM121 switchboard display	C-17
FDM128 switchboard display	C-18
<i>Wiring diagrams</i>	D-1
<i>Additional characteristics</i>	E-1
<i>Catalogue numbers</i>	F-1
<i>Glossary</i>	G-1



PowerPact H-Frame circuit breakers

15/150 A Busbar PowerPact H-Frame 150 A 3P circuit breaker

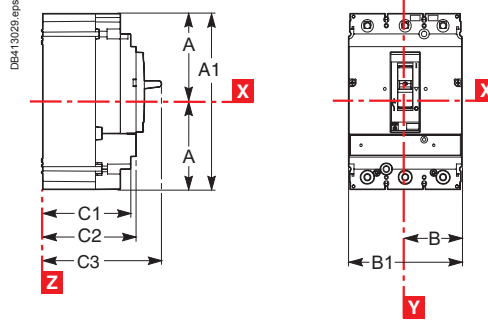
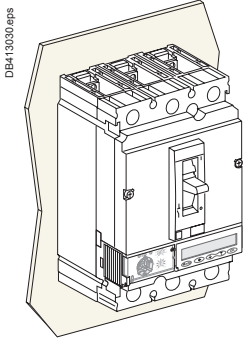

	A	A1	B	B1	C1	C2	C3
mm	162.6	81.3	52.4	104.7	82.4	87.4	110.8
inch	6.40	3.20	2.06	4.12	3.24	3.44	4.36

15/150 A lug-lug PowerPact H-Frame 3P circuit breaker

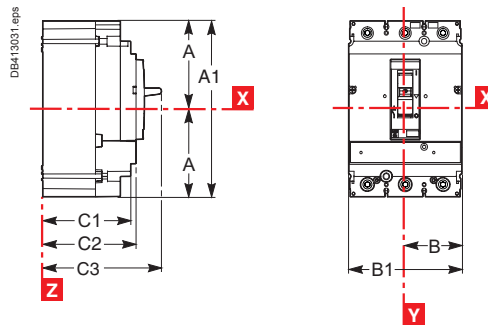
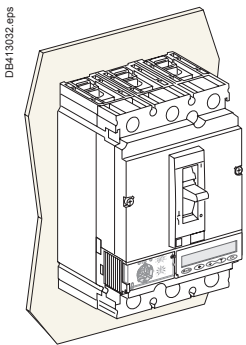

	A	A1	B	B1	C1	C2	C3
mm	162.6	81.3	52.4	104.7	82.4	87.4	110.8
inch	6.40	3.20	2.06	4.12	3.24	3.44	4.36

15/150 A rear connected PowerPact H-Frame 3P circuit breaker

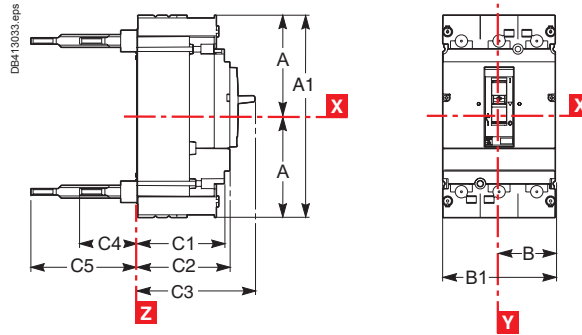
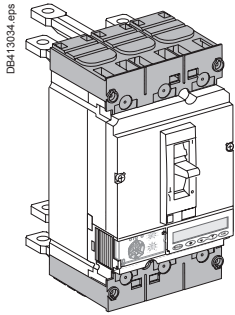

	A	A1	B	B1	C1	C2	C3	C4	C5
mm	94	188	52.4	104.7	82.4	87.4	110.8	52.4	97.4
inch	3.70	7.40	2.06	4.12	3.24	3.44	4.36	2.06	3.84

Rotary handle detail (PowerPact H-Frame circuit breaker)

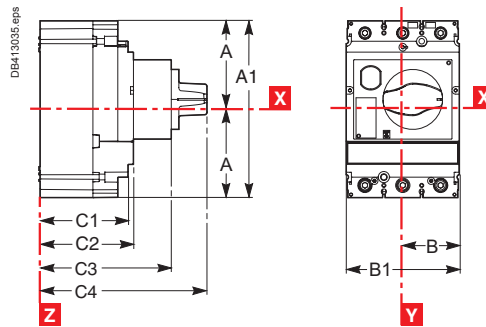
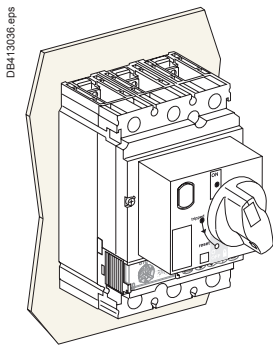

	A	A1	B	B1	C1	C2	C3	C4
mm	162.4	81.2	52.4	104.7	82.4	87.4	122.4	155.4
inch	6.40	3.20	2.06	4.12	3.24	3.44	4.82	6.12

PowerPact J-Frame circuit breakers

150/250 A busbar PowerPact J-Frame 3P circuit breaker

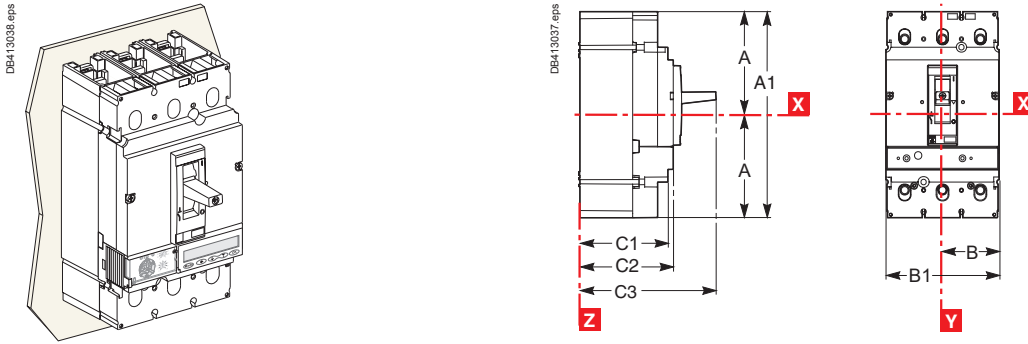

	A	A1	B	B1	C1	C2	C3
mm	95.5	191	52.4	104.7	82.4	87.4	127
inch	3.76	7.52	2.06	4.12	3.24	3.44	5.00

150/250 A lug-lug PowerPact J-Frame 3P circuit breaker

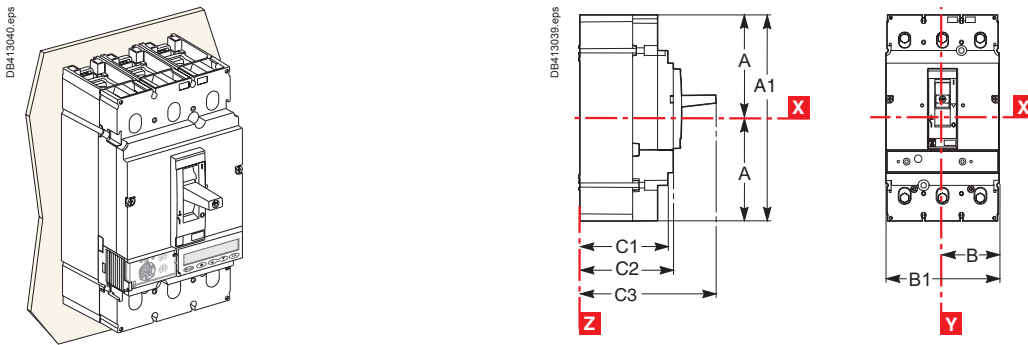

	A	A1	B	B1	C1	C2	C3
mm	95.5	191	52.4	104.7	82.4	87.4	127
inch	3.76	7.52	2.06	4.12	3.24	3.44	5.00

150/250 A rear connected PowerPact J-Frame 3P circuit breaker

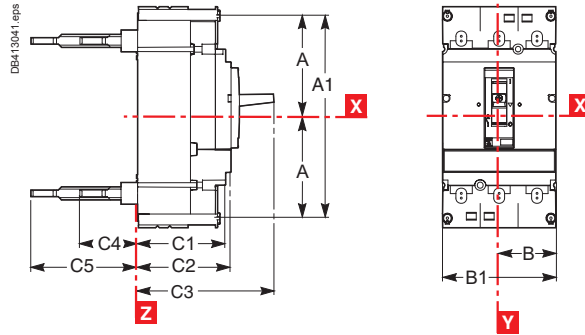
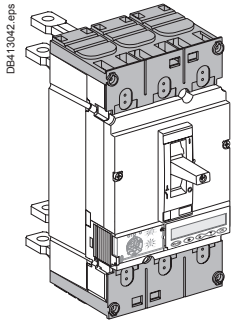

	A	A1	B	B1	C1	C2	C3	C4	C5
mm	101.6	203.2	52.4	104.7	82.4	87.4	126.9	52.3	97.5
inch	4.00	8.00	2.06	4.12	3.24	3.44	5.00	2.06	3.84

Rotary handle detail (PowerPact J-Frame circuit breaker)

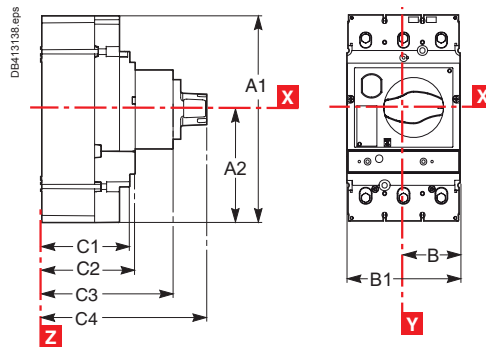
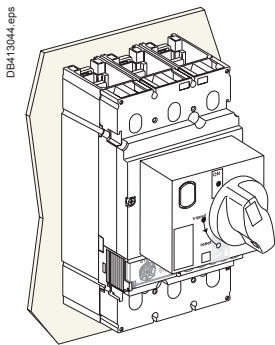

	A1	A2	B	B1	C1	C2	C3	C4
mm	191	104.5	52.4	104.7	82.4	87.4	122.4	155.4
inch	7.52	4.11	2.06	4.12	3.24	3.44	4.82	6.12

PowerPact H- and J-Frame circuit breaker door cutouts

PowerPact H- and J-Frame circuit breaker toggle handle door cutout

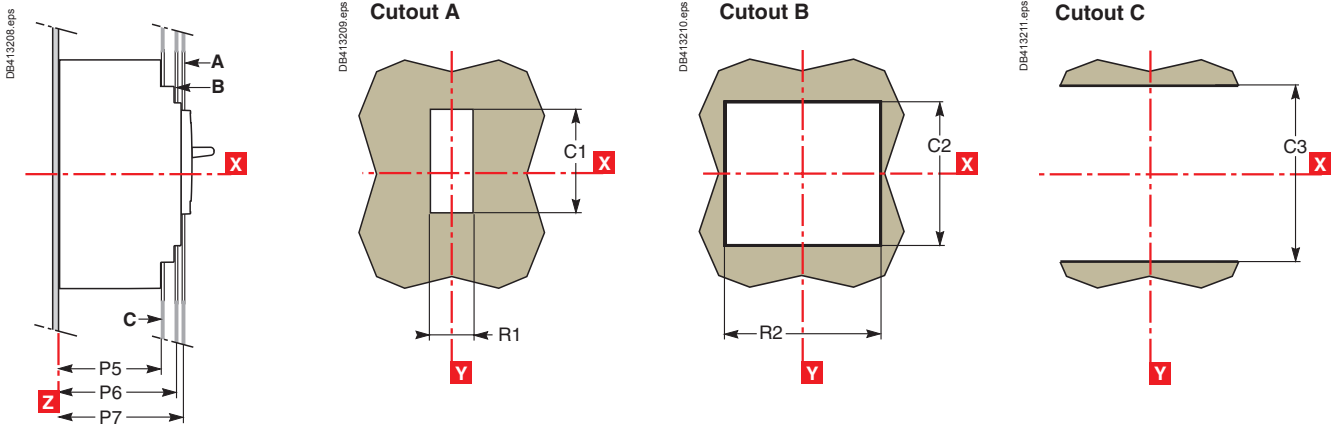

	C1	C2	C3	P5	P6	P7	R1	R2
mm	76.2	106	127.5	74.4	83.8	88.9	29	108
inch	3.00	4.17	5.02	2.93	3.30	3.50	1.14	4.25

PowerPact H- and J-Frame circuit breaker toggle handle with escutcheon door cutout

For toggle

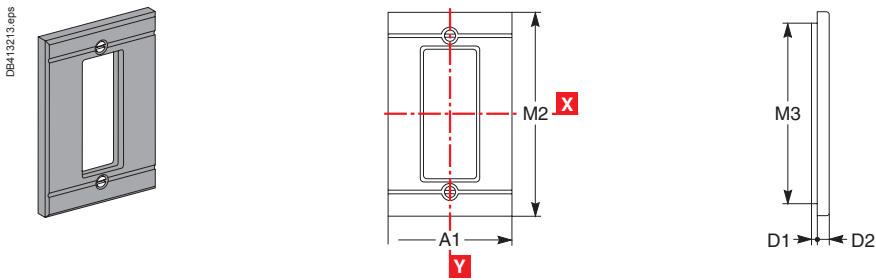

	A1	D1	D2	M2	M3
mm	102	3.5	6.5	142	115
inch	4.01	0.13	0.25	5.59	6.10

PowerPact H- and J-Frame circuit breaker fixed rotary handle cutout

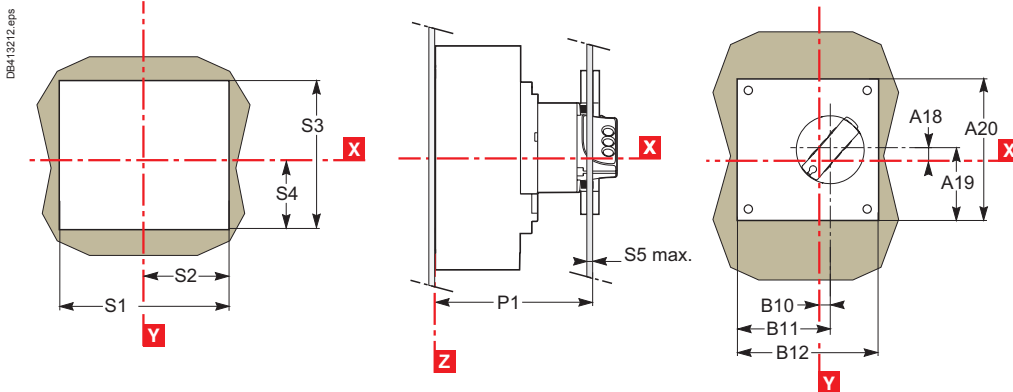

	A18	A19	A20	B10	B11	B12	P1	S1	S2	S3	S4	S5
mm	9	60	120	9.25	69	120	125	100	50	100	41	1-3
inch	0.35	2.36	4.72	0.36	2.72	4.72	4.92	3.94	1.97	3.94	1.61	0.04-0.12

PowerPact H- and J-Frame circuit breaker door mounted rotary handle cutout

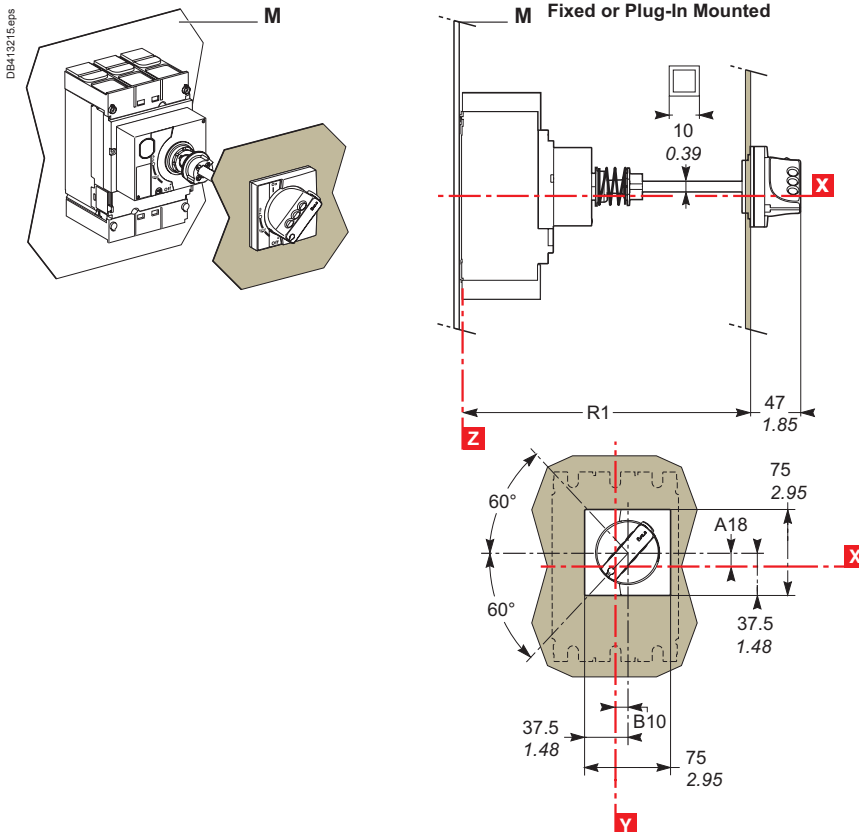

	R1 min	R1 max	A18	B10	D1
mm	171	600	9	9.25	75
inch	6.73	23.62	0.35	0.36	2.95

PowerPact L-Frame circuit breakers

PowerPact L-Frame fixed mounted electronic trip circuit breaker

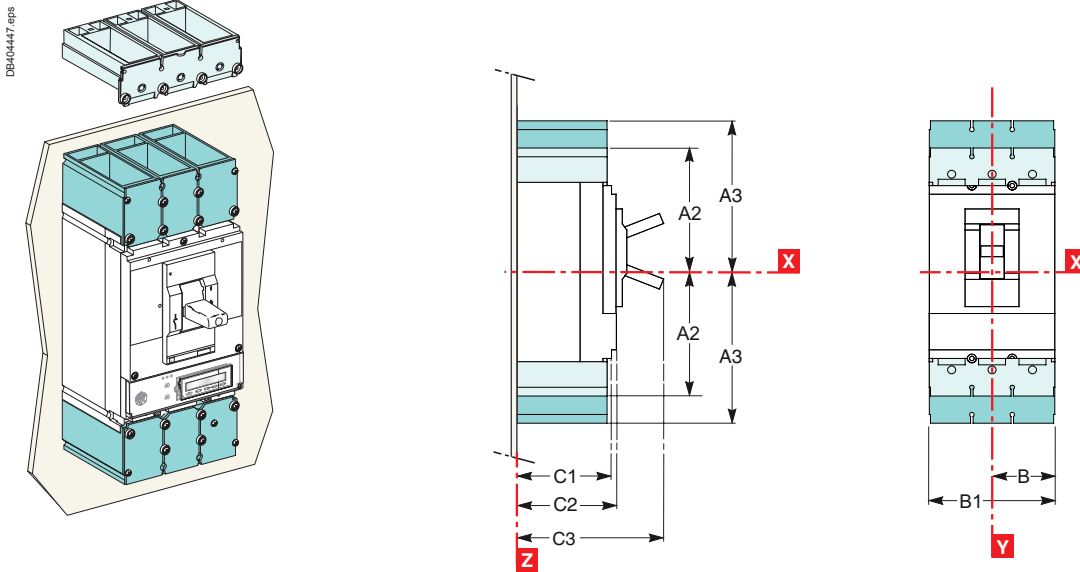

	A2	A3	B	B1	B2	C1	C2	C3
mm	143.5	200	70	140	185	95.5	110	168
inch	5.65	7.87	2.76	5.51	7.28	3.76	4.33	6.61

PowerPact L-Frame circuit breaker mounting

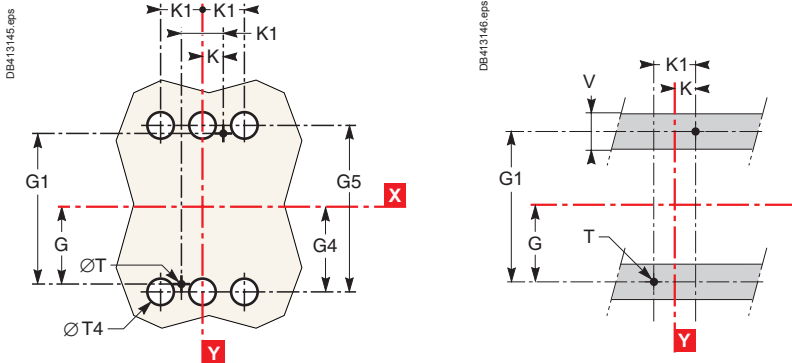

	G	G1	G4	G5	K ⁽¹⁾	K1	T	T4 ⁽²⁾	V ⁽³⁾
mm	100	200	113.5	227	22.5	45	6	32	35
inch	3.93	7.87	4.46	8.93	0.88	1.77	0.23	1.25	1.38

- (1) For 2 pole circuit breaker, the middle holes are not required.
- (2) For rear connected circuit breakers only.
- (3) V is ≤ 0.78 inch. (20 mm) on C-frame circuit breakers with secondary disconnecting blocks.

Front panel cutouts for PowerPact L-Frame fixed

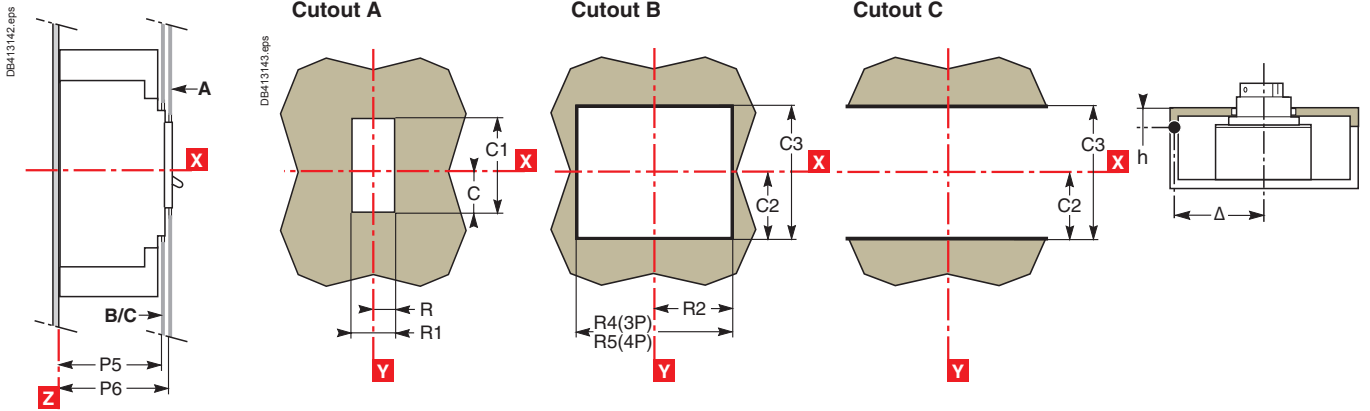

	C	C1	C2	C3	P5	P6	R	R1	R2	R4	R5	Δ
mm	41.5	116	92.5	184	107	112	31.5	63	71.5	143	188	100 + (5 x h)
inch	1.63	4.56	3.64	7.24	4.21	4.40	1.24	2.48	2.81	5.62	7.40	3.93 + (5 x h)

PowerPact L-Frame circuit breaker front panel cutouts for toggle boot and escutcheon

With toggle boot

With escutcheon

Door hinge point

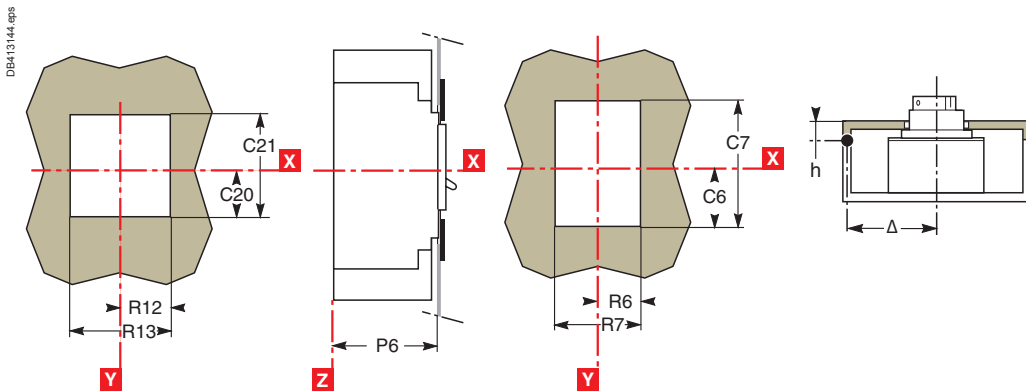

	C6	C7	C20	C21	P6	R6	R7	R12	R13	Δ
mm	53	146	46.5	46.5	12	46.5	93	63	126	100 + (5 x h)
inch	2.08	5.74	1.83	1.83	4.40	1.83	3.66	2.48	4.96	3.93 + (5 x h)

PowerPact L-Frame circuit breakers

PowerPact L-Frame circuit breaker mounting through a backplate

Plug-in base

Cradle

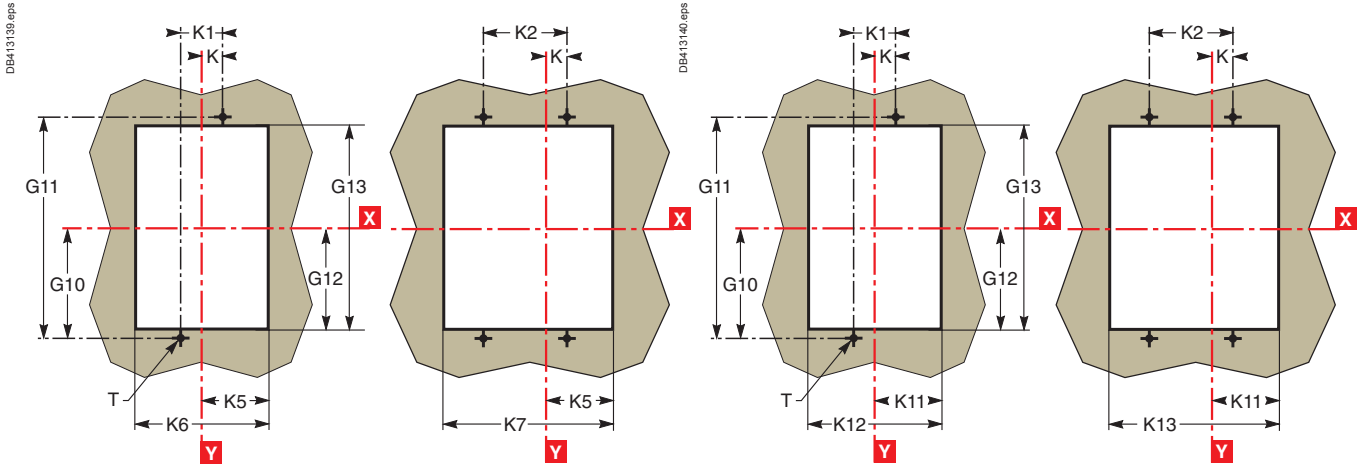

	G10	G11	G12	G13	K	K1	K2	K5	K6	K7	K11	K12	K13
mm	150	300	137	274	22.5	45	90	71.5	143	188	91.5	183	91.5
inch	5.90	11.8	5.39	10.7	0.88	1.77	3.54	2.81	2.81	7.4	7.40	3.60	7.20

PowerPact L-Frame circuit breaker mounting on rails (plug-in base or cradle)

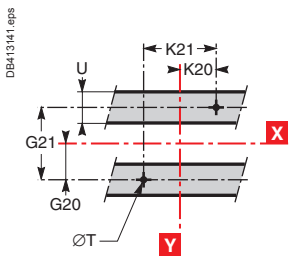

	G20	G21	K20	K21	T	U
mm	75	150	50	100	3	35
inch	2.95	5.90	8.97	1.96	0.11	1.38

PowerPact L-Frame circuit breaker handles and handle operators

PowerPact L-Frame circuit breaker motor operators

DB413147.eps

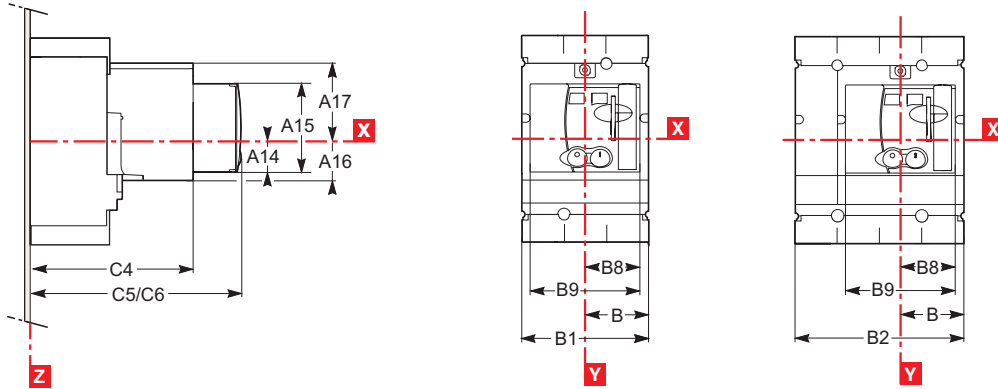

C5: without keylock
C6: with keylock

	A14	A15	A16	A17	B	B1	B2	B8	B9	C4	C5	C6
mm	40	123	52	100	70	140	185	61.5	123	215	256	258
inch	1.57	4.84	2.05	3.94	2.76	5.51	7.28	2.42	4.84	8.46	10.08	10.16

PowerPact L-Frame circuit breaker handles and handle operators

PowerPact L-Frame circuit breaker rotary-operating handles

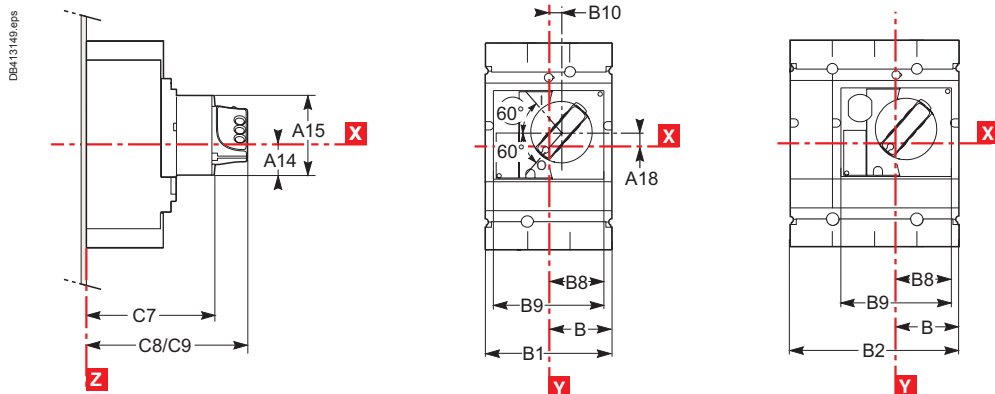

C8: without keylock
C9: with keylock

	A14	A15	A18	B	B1	B2	B8	B9	B10	C7	C8	C9
mm	40	123	24.6	70	140	185	61.5	123	5	145	179	188
inch	1.57	4.84	0.97	2.76	5.51	7.28	2.42	4.84	0.20	5.71	7.05	7.40

PowerPact L-Frame motor-control center circuit breaker direct rotary-operating handle

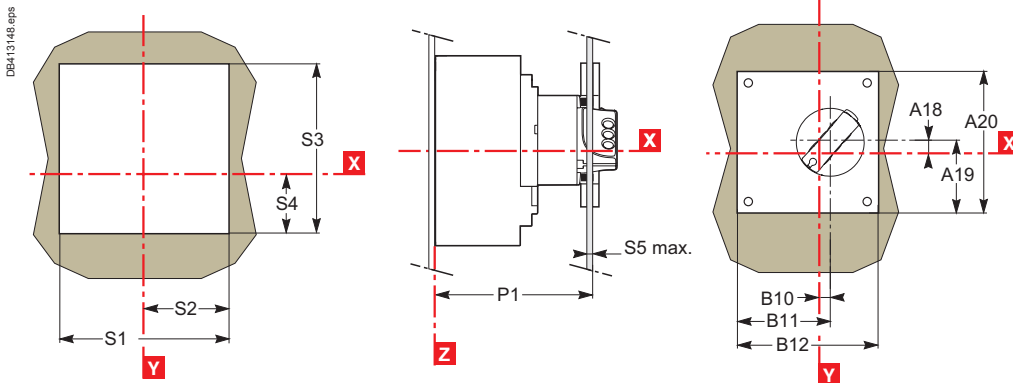

	A18	A19	A20	B10	B11	B12	P1	S1	S2	S3	S4	S5
mm	24.6	83	160	5	85	160	149	145	75	145	51	1-3
inch	0.97	3.27	6.30	0.20	3.35	6.30	5.87	5.71	2.95	5.71	2.01	0.04-0.12

PowerPact L-Frame circuit breaker extended rotary handle mounting

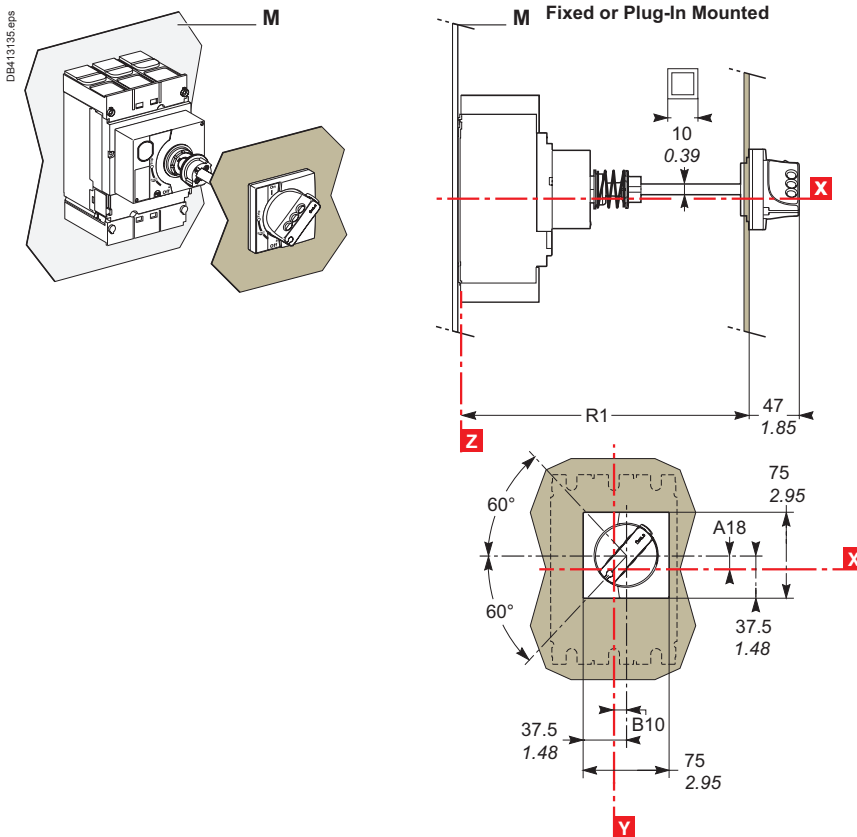

	R1 min	R1 max	R2 min	R2 max	A18	B10	D1
mm	195	600	272	600	24.6	5	100
inch	7.68	23.62	10.71	23.62	0.97	0.20	3.94

PowerPact L-Frame circuit breaker handles and handle operators

PowerPact L-Frame circuit breaker front-panel escutcheons

For toggle

DB413157.eps

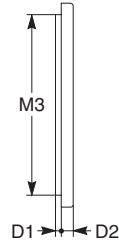
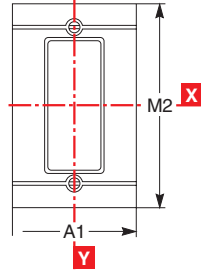
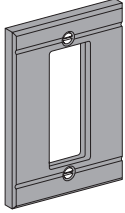

	A1	D1	D2	M2	M3
mm	102	3.5	6.5	115	142
inch	4.01	0.13	0.25	6.10	5.59

PowerPact L-Frame circuit breaker connectors

PowerPact L-Frame circuit breaker fixed-mounted connections

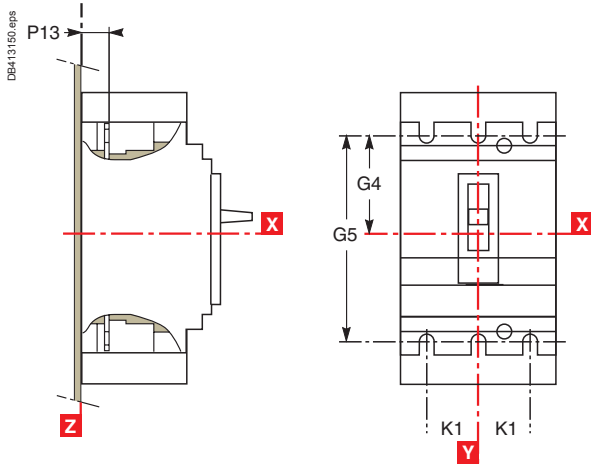

	G4	G5	K1	P13
mm	113.5	227	45	526
inch	4.46	8.93	1.77	1.02

PowerPact L-Frame circuit breaker front connections

Front connections

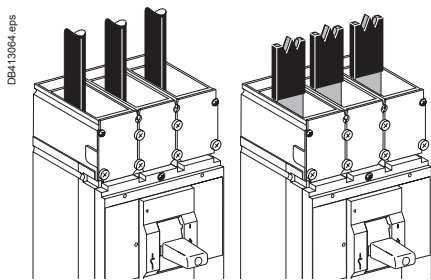

Busbar connection
M10 screws

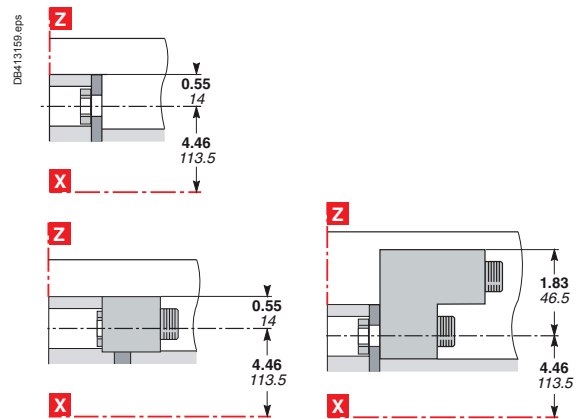

PowerPact L-Frame circuit breaker rear connections

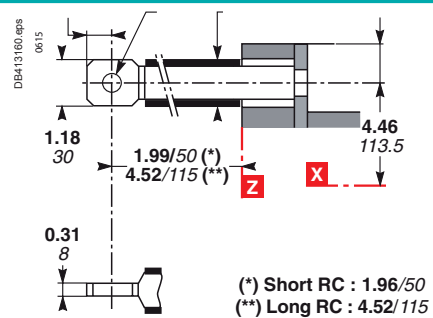
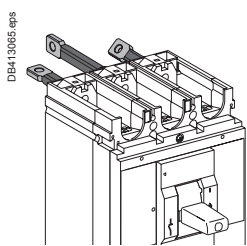

I/O (Input/Output) application module

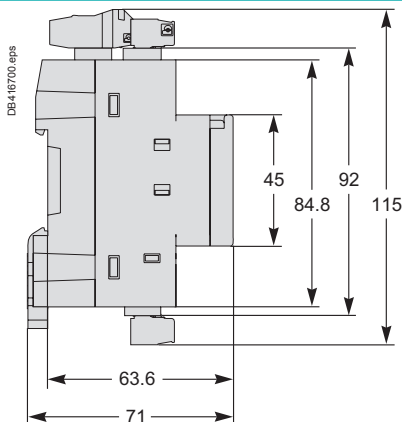
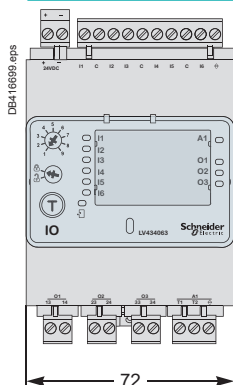

IFM - Modbus-SL interface

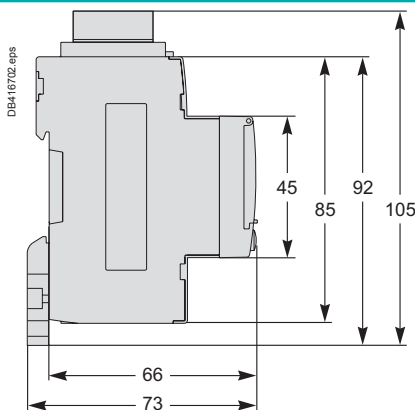
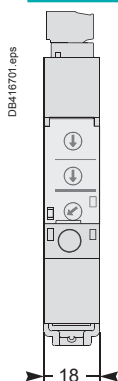

IFE - Ethernet interface

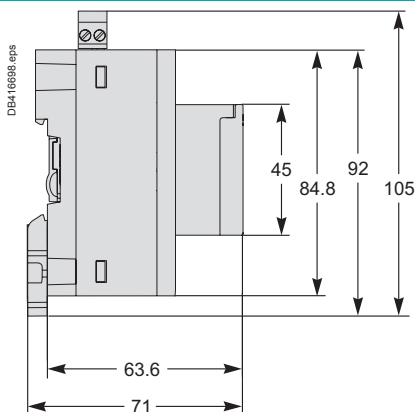
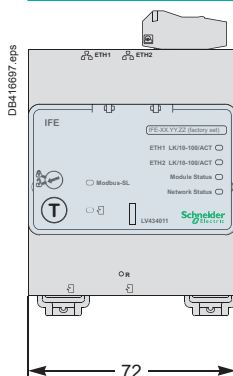

Com'X 200

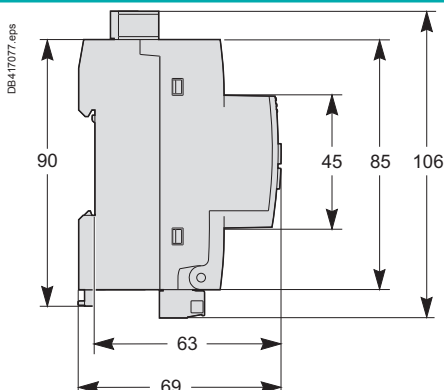
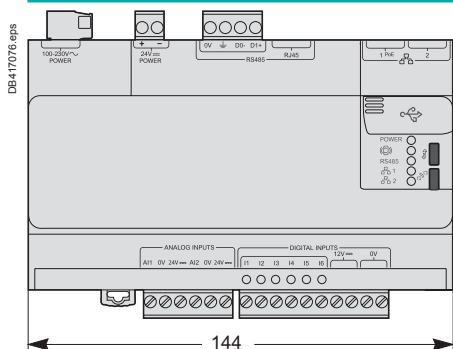

FDM121 switchboard display

Dimensions

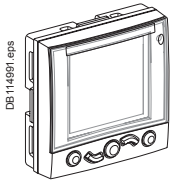

DB114991.eps

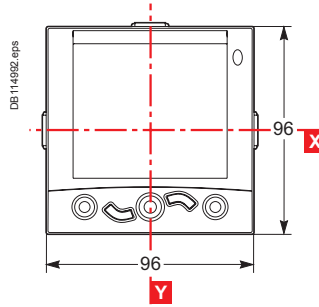

DB114992.eps

Mounting

Through panel

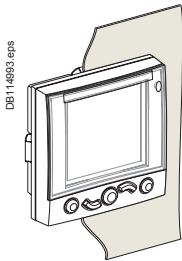

DB114993.eps

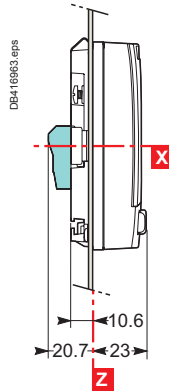

DB416953.eps

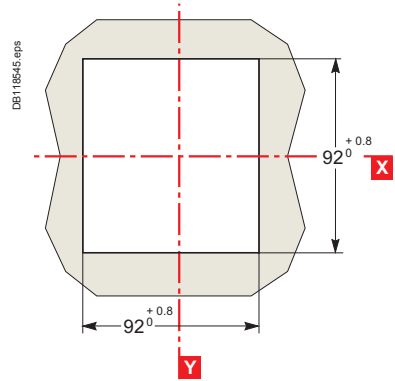

DB116545.eps

On panel

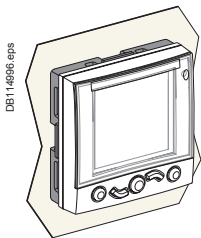

DB114996.eps

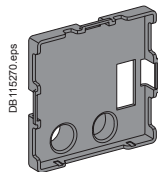

DB115270.eps

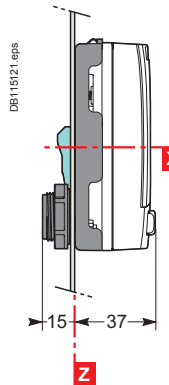

DB115121.eps

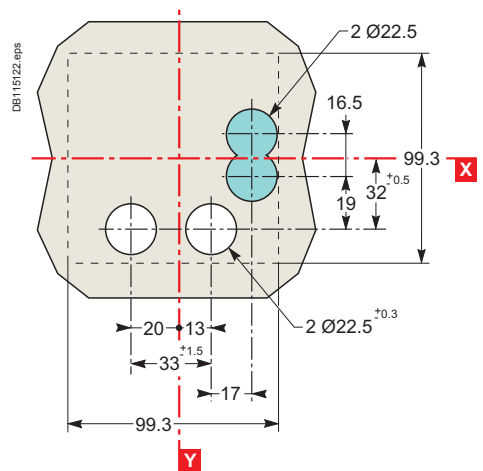

DB115122.eps

 Connector (optional).

Dimensions

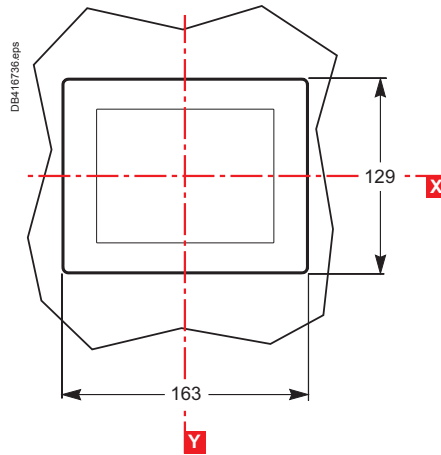
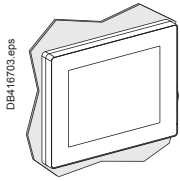

Mounting

On panel

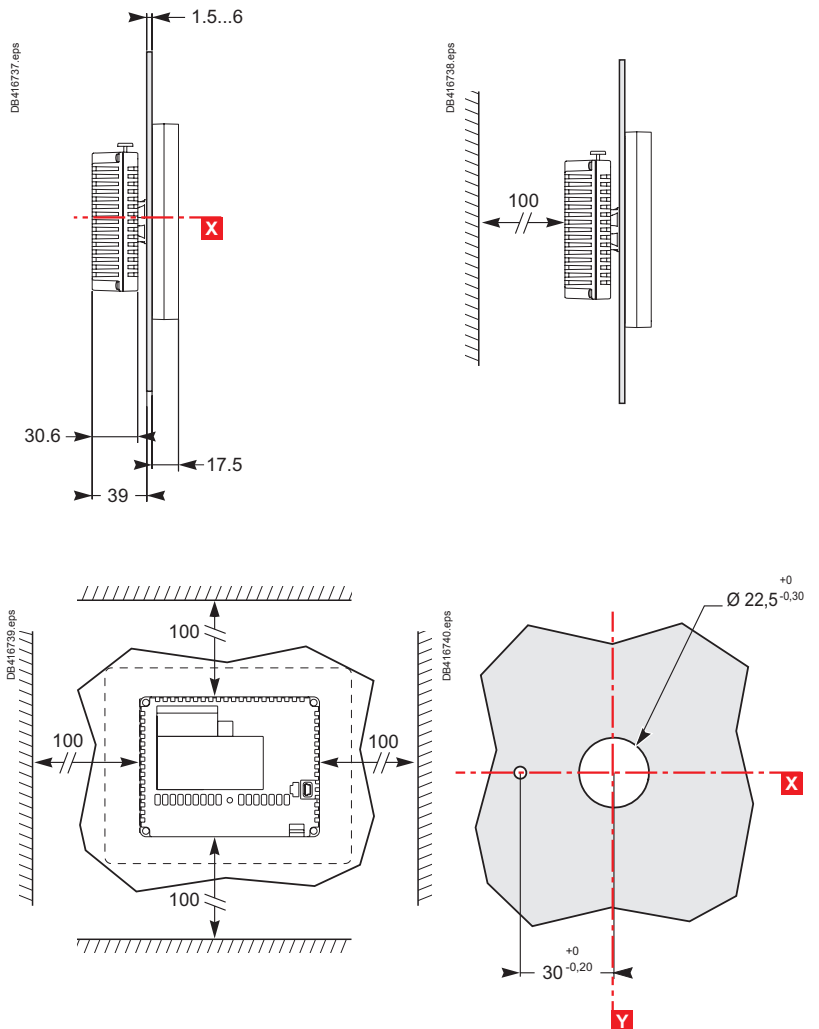
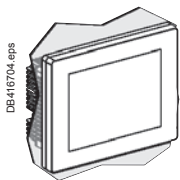

<i>Functions and characteristics</i>	A-1
<i>Installation recommendations</i>	B-1
<i>Dimensions</i>	C-1
Wiring diagrams	D-2
<hr/>	
PowerPact	
Communication	D-5
SDx module with Micrologic	D-7
<i>Additional characteristics</i>	E-1
<i>Catalogue numbers</i>	F-1
<i>Glossary</i>	G-1



Unit-mount circuit breakers

Power

Micrologic trip unit

Remote operation

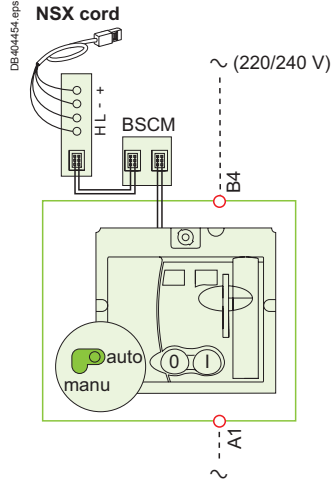
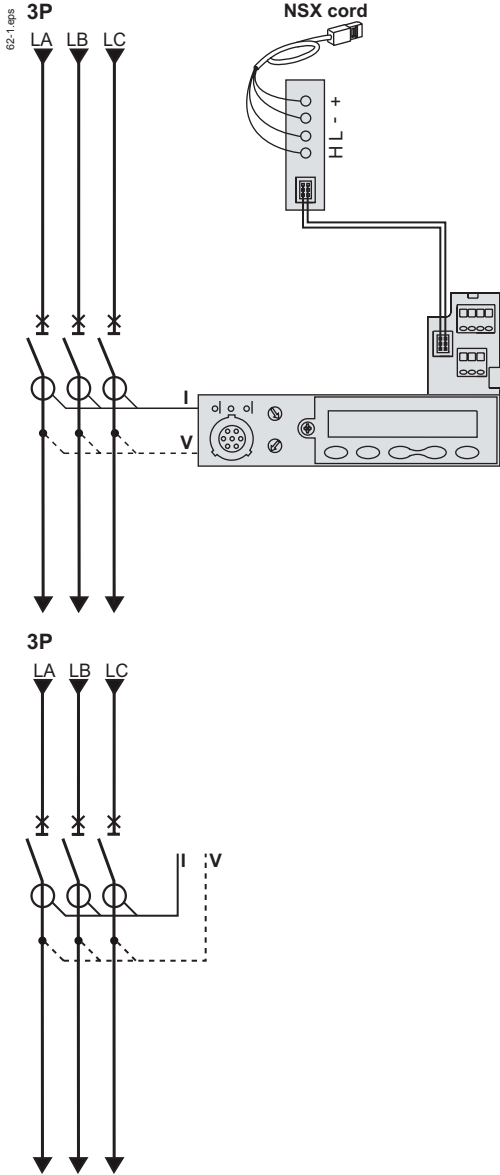

Unit-mount circuit breakers

Indication contacts

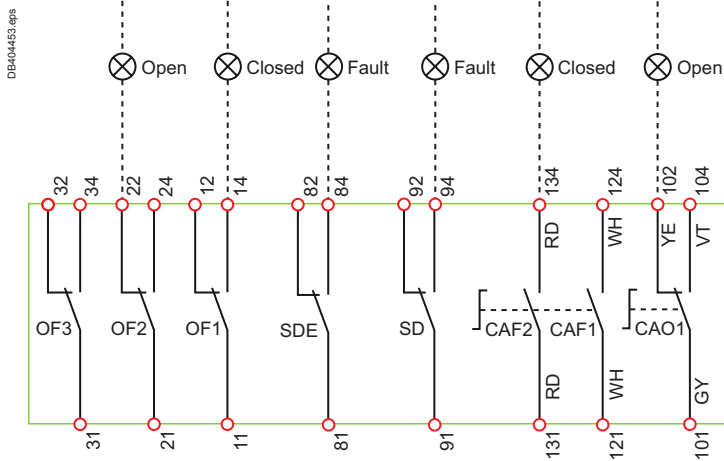

The diagram is shown with circuits de-energized, relays in normal position, and all devices open, connected, and charged.

Terminal connections shown as ○ must be connected by the customer.

Remote operation

MN	Undervoltage Release
or	
MX	Shunt Release

Indication contacts

OF2/OF1	Device ON/OFF Auxiliary Switches
OF3	Device ON/OFF Auxiliary Switches (L-Frame)
SDE	Overcurrent Trip Switch (short-circuit, overload, ground fault, earth leakage)
SD	Alarm Switch
CAF2/CAF1	Early-Make Contact (rotary handle only)
CAO1	Early-Break Contact (rotary handle only)

Micrologic trip unit E

E	Communication H (WH), L (BL): data -(BK), +(RD): 24 Vdc power supply
----------	--

Color code for auxiliary wiring

RD: Red	VI: Violet
WH: White	GY: Gray
YE: Yellow	OR: Orange
BK: Black	BL: Blue
GN: Green	

SDx module with Micrologic trip unit

Symbols

SD1, SD3: SDx Module Power Supply
SD2: Output 1 (80 mA max.)
SD4: Output 2 (80 mA max.)

	SD2	SD4
Micrologic 3	SDT	-
Micrologic 5	SDT or Output 1	PAL Ir or Output 2

Terminal connections shown as **○** must be connected by the customer.

Note: The diagram is shown with circuits de-energized, relays in normal position, and all devices open, connected, and charged.

Connection

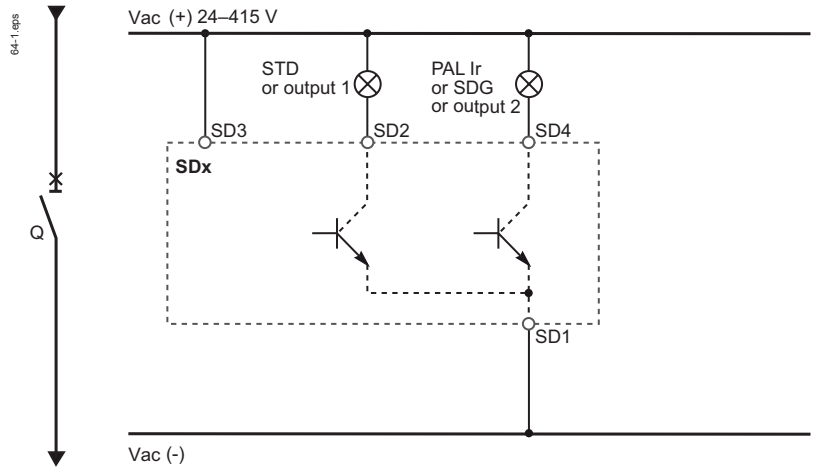

Operation

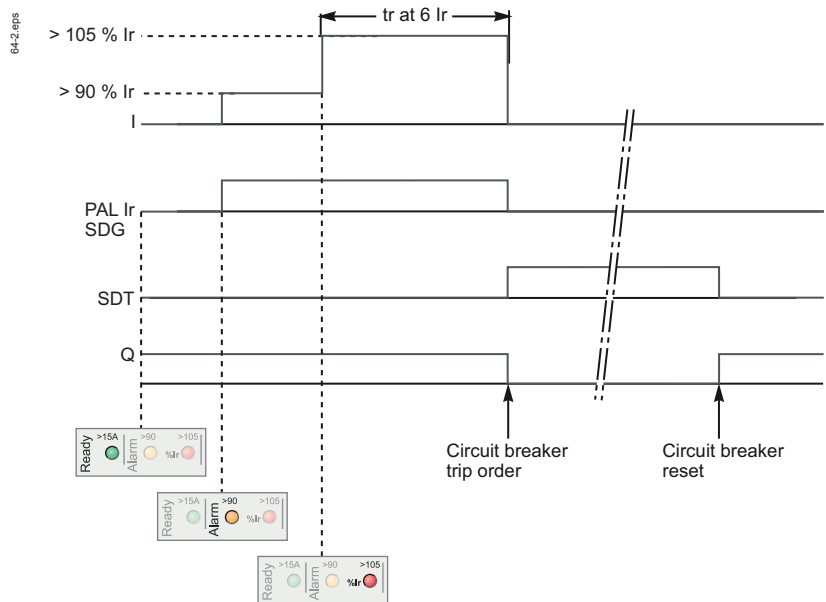

- I:** charge current
- PAL Ir:** thermal overload pre-alarm
- SDG:** ground-fault signal
- SDT:** thermal-fault signal
- Q:** circuit breaker

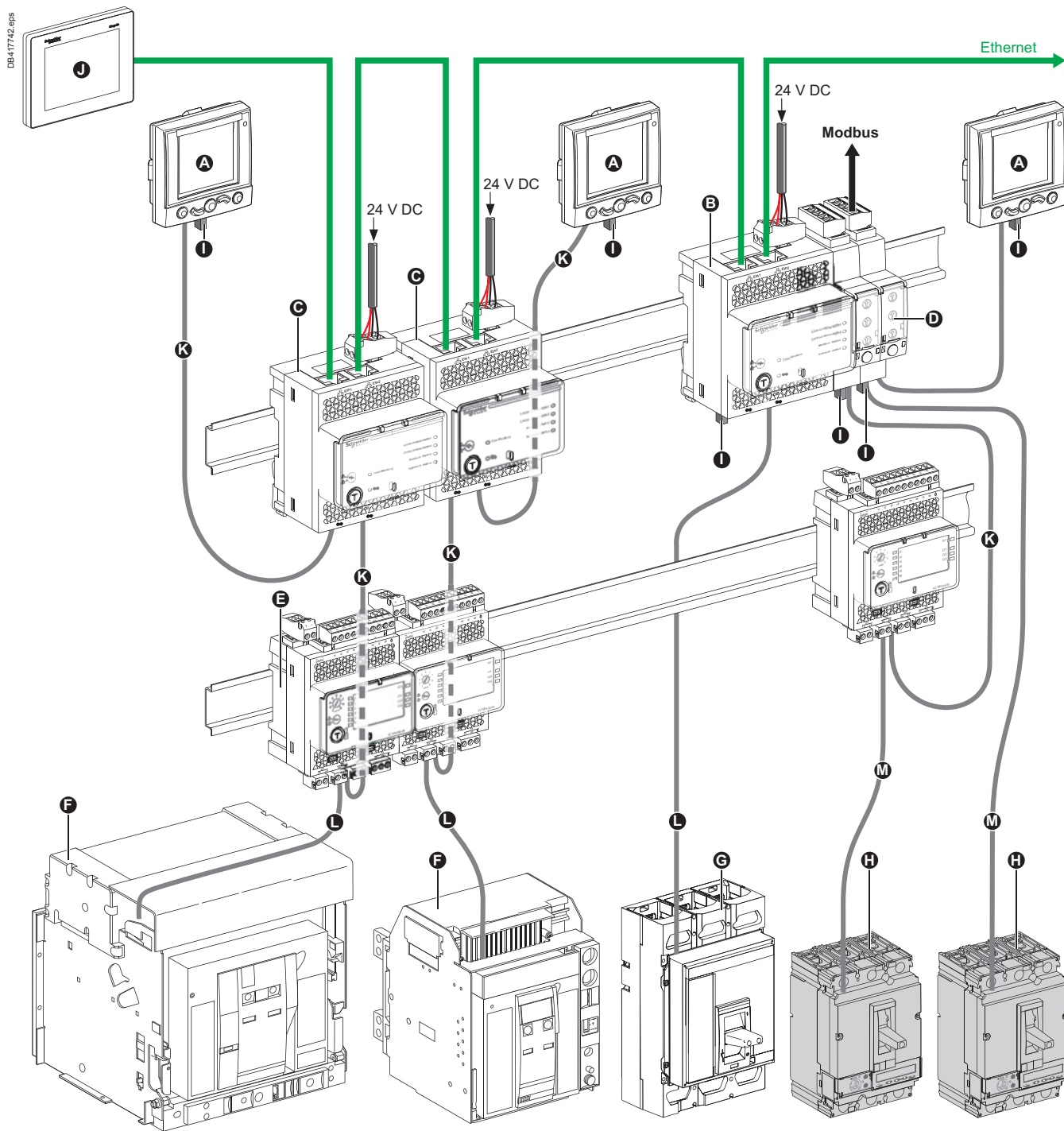

- A** FDM121 (TRV00121)
- B** IFE master (LV434011)
- C** IFE (LV434010)
- D** IFM (TRV00210)
- E** I/O application module (LV434063)
- F** Masterpact NT/NW
- G** Compact NS630b-3200
- H** PowerPact
- I** ULP termination (TRV00880)
- J** FDM128 (LV434128)

- K** ULP cable
- L** Breaker ULP cord
- M** NSX cord
- Ethernet
- Modbus

PowerPact Communication

DE417744.gps

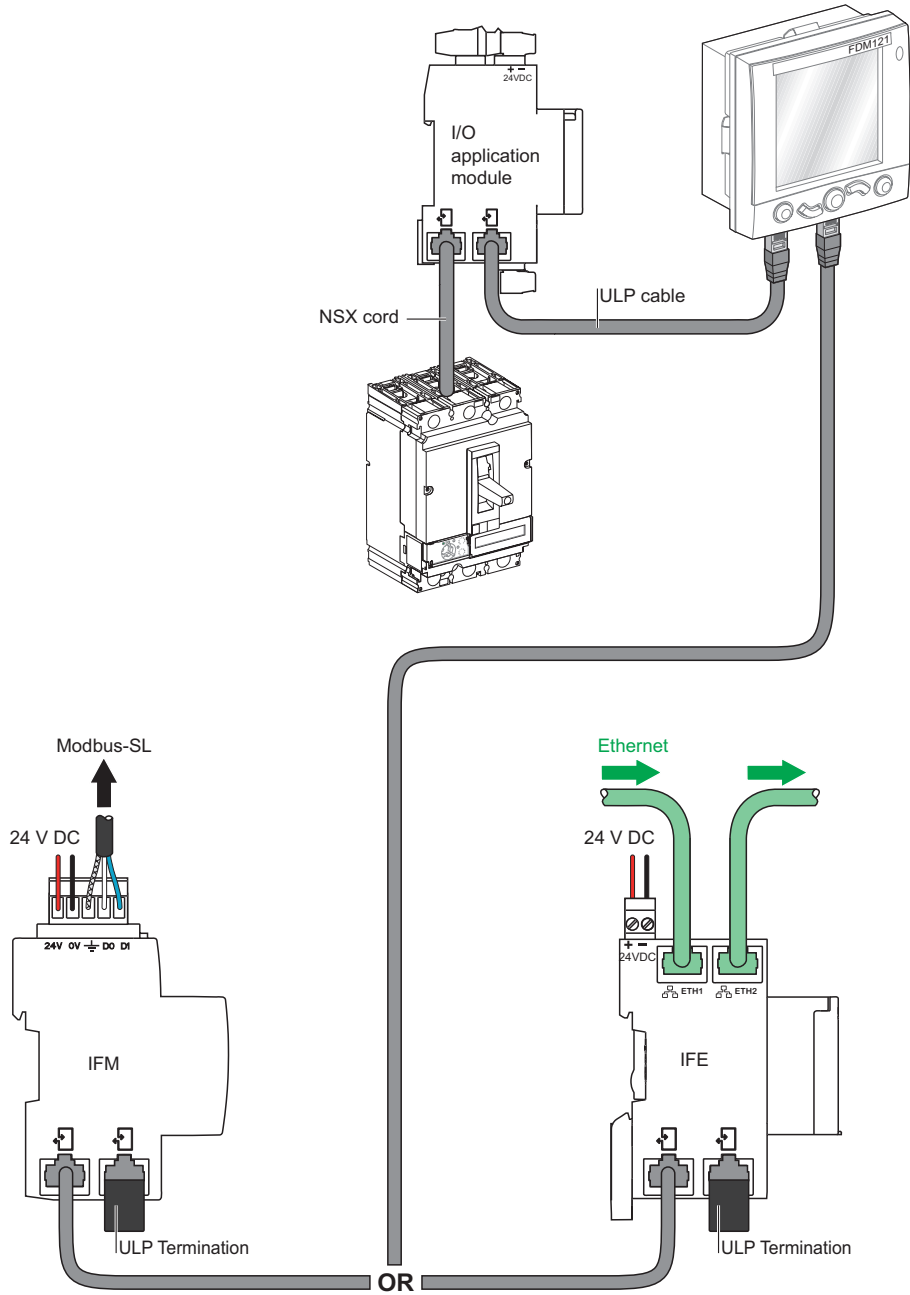

PowerPact SDx module with Micrologic

The diagram is shown with circuits de-energised, all devices open, connected and charged and relays in normal position.

Symbols

- SD1, SD3:** SDx-module power supply
- SD2:** output 1 (80 mA max.)
- SD4:** output 2 (80 mA max.)

	SD2	SD4
Micrologic 3	SDT	-
Micrologic 5	SDT or output 1	PAL Ir or output 2

Terminals shown in red ○ must be connected by the customer.

Connection

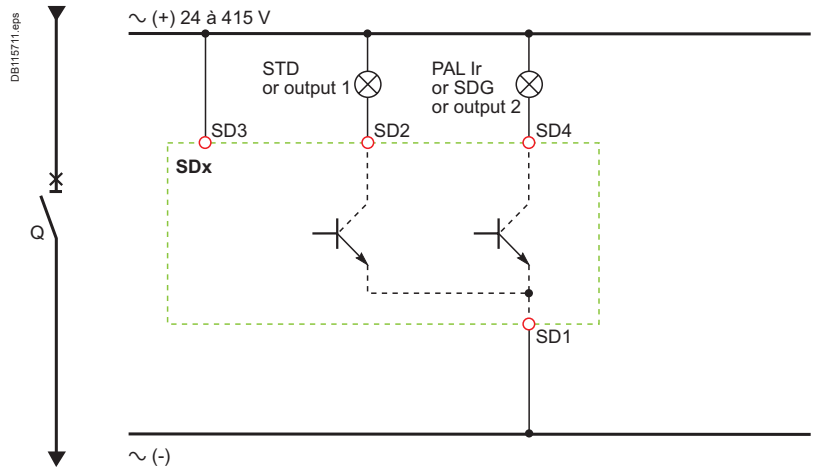

Operation

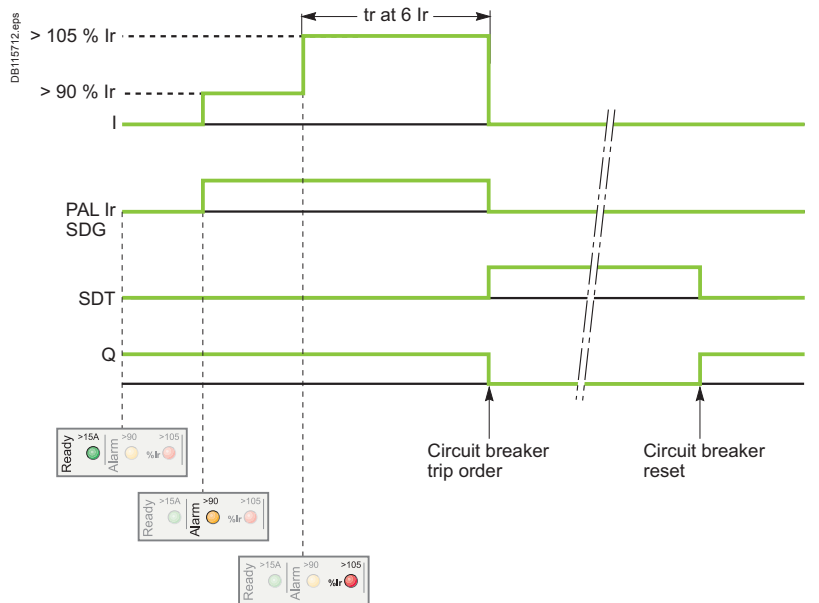

- I:** Charge Current
- PAL Ir:** Thermal Overload Pre-Alarm
- SDG:** Ground-Fault Signal
- SDT:** Thermal-Fault Signal
- Q:** Circuit Breaker

<i>Functions and characteristics</i>	A-1
<i>Installation recommendations</i>	B-1
<i>Dimensions</i>	C-1
<i>Wiring diagrams</i>	D-1
PowerPact™ H-, J-, and L-Frame Circuit Breakers	
H-Frame 15–35 A (HD, HG, HJ, and HL) Thermal-Magnetic Trip	E-3
H-Frame 40–60 A (HD, HG, HJ, and HL) Thermal-Magnetic Trip	E-4
H-Frame 70–100 A (HD, HG, HJ, and HL) Thermal-Magnetic Trip	E-5
H-Frame 110–150 A (HD, HG, HJ, and HL) Thermal-Magnetic Trip	E-6
J-Frame 150–250 A (JD, JG, JJ, JL, and JR) Thermal-Magnetic Trip	E-7
H-Frame 150 A Typical Peak Let-Through Curves	E-8
H-Frame 150 A Typical I _{2t} Let-Through Curves	E-9
J-Frame 250 A Typical Peak Let-Through Curves	E-10
J-Frame 250 A Typical I _{2t} Let-Through Curves	E-11
H-Frame UL Listed Current-Limiting Circuit Breaker	E-12
H-Frame UL Listed Current-Limiting Circuit Breaker	E-13
J-Frame UL Listed Current-Limiting Circuit Breaker	E-14
J-Frame UL Listed Current-Limiting Circuit Breaker	E-15
Micrologic 3.2 Electronic Trip Unit Long Time Trip Curve	E-16
Micrologic 3.2S Electronic Trip Unit Long Time / Short Time Trip Curve	E-17
Micrologic 3.2/3.2S/5.2A/5.2E/6.2A/6.2E Electronic Trip Unit Instantaneous Trip Curve	E-18
Micrologic 5.2A/5.2E/6.2A/6.2E Electronic Trip Unit Long Time Trip Curve	E-19
Micrologic 5.2A/5.2E/6.2A/6.2E Electronic Trip Unit Short Time Trip Curve	E-20
Micrologic 6.2A/6.2E Electronic Trip Unit Ground Fault Trip Curve	E-21
Micrologic 6.2A/6.2E Electronic Trip Unit Ground Fault Trip Curve	E-22
Micrologic 2.2 M Electronic Trip Unit Overload Trip Curve	E-23
Micrologic 3.2 and 3.2-W Electronic Trip Unit Long-Time Trip Curve	E-24
Micrologic 3.2S and 3.2S-W Electronic Trip Unit Long Time / Short Time Trip Curve	E-25
Micrologic 3.2, 3.2-W, 3.2S, 3.2S-W, 5.2A, 5.2A-W, 5.2E, 5.2E-W, 6.2A, 6.2A-W, 6.2E, and 6.2E-W Electronic Trip Curve Instantaneous Trip Curve	E-26
Micrologic 5.2A, 5.2A-W, 5.2E, 5.2E-W, 6.2A, 6.2A-W, 6.2E, and 6.2E-W Electronic Trip Unit Long Time Trip Curve	E-27
Micrologic 5.2A, 5.2A-W, 5.2E, 5.2E-W, 6.2A, 6.2A-W, 6.2E, and 6.2E-W Electronic Trip Unit Short Time Trip Curve	E-28
Micrologic 6.2A, 6.2A-W, 6.2E, and 6.2E-W Electronic Trip Unit Ground Fault Trip Curve	E-29
Micrologic 2.2 M Electronic Trip Unit Overload Trip Curve	E-30
Micrologic 3.3 and 3.3-W Electronic Trip Unit Long Time Trip Curve	E-31
Micrologic 2.2 M Electronic Trip Unit Overload Trip Curve	E-32
Micrologic 3.3, 3.3-W, 3.3S, and 3.3S-W Electronic Trip Unit Instantaneous Trip Curve	E-33
Micrologic 3.3, 3.3-W, 3.3S, 3.3S-W, 5.3A, 5.3A-W, 5.3E, 5.3E-W, 6.3A, 6.3A-W, 6.3E, and 6.3E-W Electronic Trip Unit Instantaneous Trip Curve	E-34
Micrologic 5.3A, 5.3A-W, 5.3E, 5.3E-W, 6.3A, 6.3A-W, 6.3E, and 6.3E-W Electronic Trip Unit Long Time Trip Curve	E-35
Micrologic 5.3, 5.3A-W, 5.3E, 5.3E-W, 6.3A, 6.3A-W, 6.3E, and 6.3E-W Electronic Trip Unit Short Time Trip Curve	E-36

Micrologic 1.3 M Electronic Trip Unit Instantaneous Trip Curve	E-37
Micrologic 2.3 M Electronic Trip Unit Overload Trip Curve	E-38
Micrologic 3.3 and 3.3W Electronic Trip Unit Long Time Trip Curve	E-39
Micrologic 3.3S and 3.3S-W Electronic Trip Unit Long Time / Short Time Trip Curve	E-40
Micrologic 3.3, 3.3-W, 3.3S, 3.3S-W, 5.3A, 5.3A-W, 5.3E, 5.3E-W, 6.3A, 6.3A-W, 6.3E, and 6.3E-W Electronic Trip Unit Instantaneous Trip Curve	E-41
Micrologic 5.3A, 5.3A-W, 5.3E, 5.3E-W, 6.3A, 6.3A-W, 6.3E, and 6.3E-W Electronic Trip Unit Long Time Trip Curve	E-42
Micrologic 5.3A, 5.3A-W, 5.3E, 5.3E-W, 6.3A, 6.3A-W, 6.3E, and 6.3E-W Electronic Trip Unit Short Time Trip Curve	E-43
Micrologic 6.3A, 6.3A-W, 6.3E, and 6.3E-W Ground-Fault Trip Curve	E-44
Micrologic 1.3 M Electronic Trip Unit Instantaneous Trip Curve	E-45
L-Frame 600 A Typical Peak Let-Through Curves	E-46
L-Frame 600 A Typical I _{2t} Let-Through Curves	E-47
L-Frame UL Listed Current-Limiting Circuit Breaker	E-48
L-Frame UL Listed Current-Limiting Circuit Breaker	E-49
L-Frame Circuit Breaker Reflex Tripping	E-49

Distribution system

Plates for mounting on busbars	E-50
--------------------------------	------

Catalogue numbers

F-1

Glossary

G-1

H-Frame 15–35 A (HD, HG, HJ, and HL) Thermal-Magnetic Trip

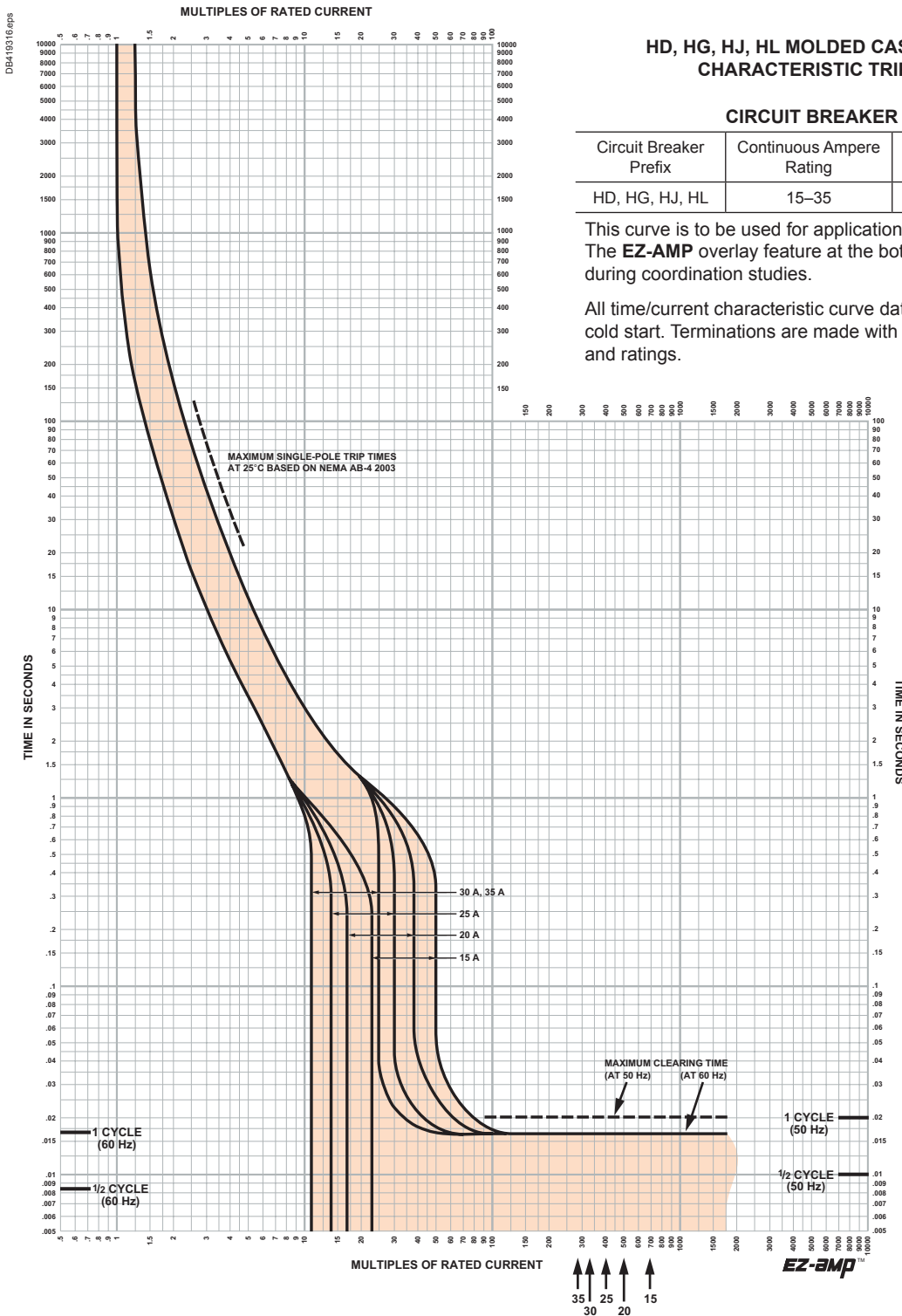

HD, HG, HJ, HL MOLDED CASE CIRCUIT BREAKERS
CHARACTERISTIC TRIP CURVE NO. 50-1

CIRCUIT BREAKER INFORMATION

Circuit Breaker Prefix	Continuous Ampere Rating	Maximum AC Voltage	Number of Poles
HD, HG, HJ, HL	15–35	600	2, 3

This curve is to be used for application and coordination purposes only. The **EZ-AMP** overlay feature at the bottom of the page should be used during coordination studies.

All time/current characteristic curve data is based on 40 °C ambient cold start. Terminations are made with conductors of appropriate length and ratings.

PowerPact™ H-, J-, and L-Frame Circuit Breakers

H-Frame 40–60 A (HD, HG, HJ, and HL) Thermal-Magnetic Trip

HD, HG, HJ, HL MOLDED CASE CIRCUIT BREAKERS CHARACTERISTIC TRIP CURVE NO. 50-2

CIRCUIT BREAKER INFORMATION

Circuit Breaker Prefix	Continuous Ampere Rating	Maximum AC Voltage	Number of Poles
HD, HG, HJ, HL	40–60	600	2, 3

This curve is to be used for application and coordination purposes only. The **EZ-AMP** overlay feature at the bottom of the page should be used during coordination studies.

All time/current characteristic curve data is based on 40 °C ambient cold start. Terminations are made with conductors of appropriate length and ratings.

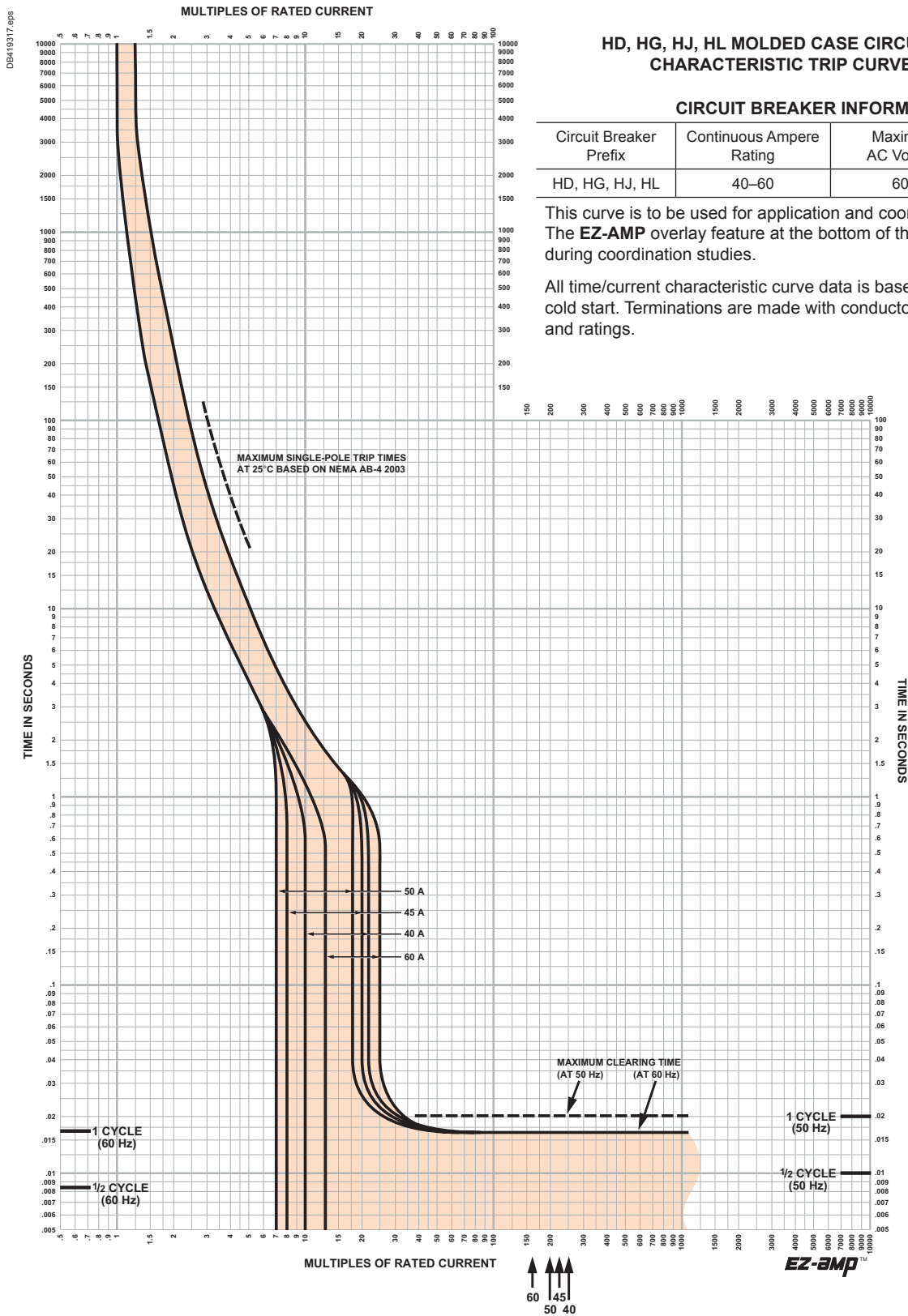

PowerPact™ H-, J-, and L-Frame Circuit Breakers

H-Frame 70–100 A (HD, HG, HJ, and HL) Thermal-Magnetic Trip

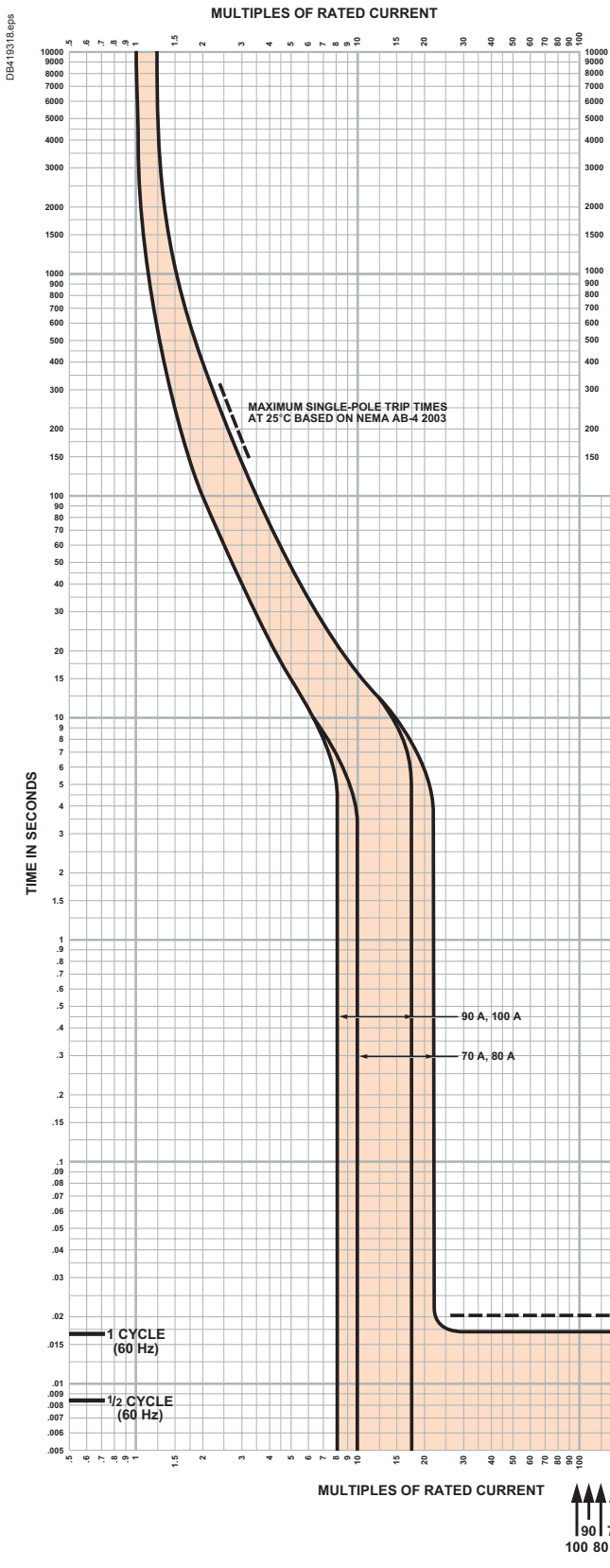

HD, HG, HJ, HL MOLDED CASE CIRCUIT BREAKERS
CHARACTERISTIC TRIP CURVE NO. 50-3

CIRCUIT BREAKER INFORMATION

Circuit Breaker Prefix	Continuous Ampere Rating	Maximum AC Voltage	Number of Poles
HD, HG, HJ, HL	70–100	600	2, 3

This curve is to be used for application and coordination purposes only. The **EZ-AMP** overlay feature at the bottom of the page should be used during coordination studies.

All time/current characteristic curve data is based on 40 °C ambient cold start. Terminations are made with conductors of appropriate length and ratings.

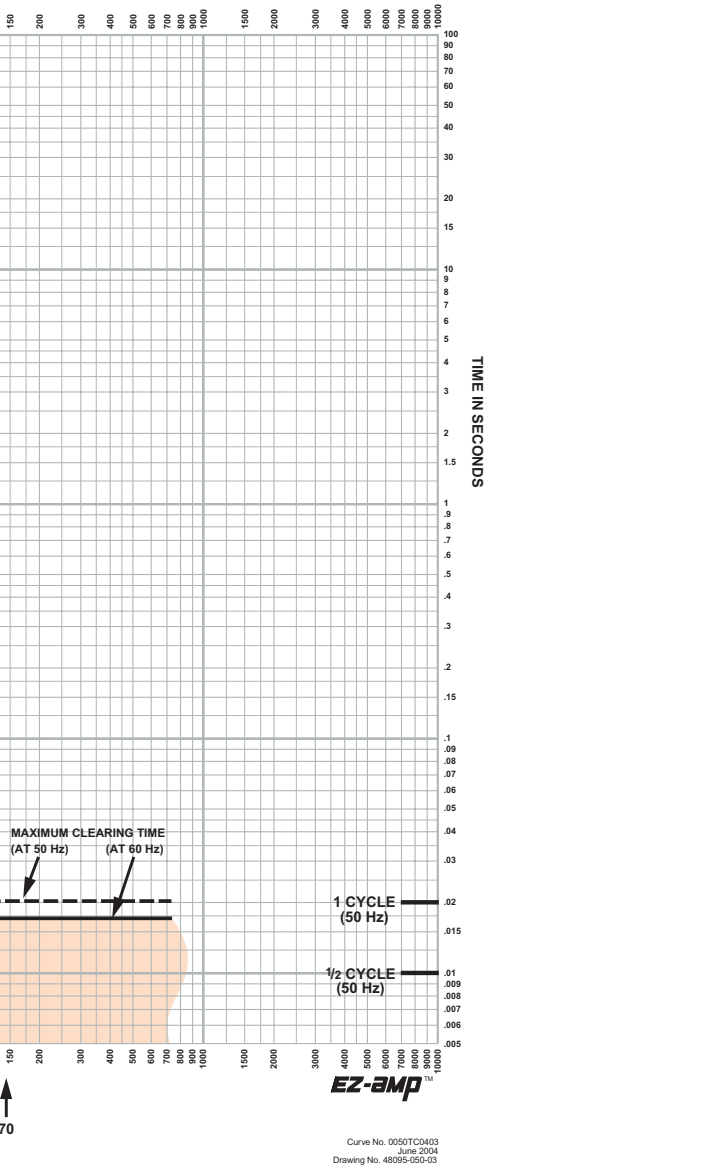

Curve No. 0050TC0403
June 2004
Drawing No. 48005-000-03

PowerPact™ H-, J-, and L-Frame Circuit Breakers

H-Frame 110–150 A (HD, HG, HJ, and HL) Thermal-Magnetic Trip

HD, HG, HJ, HL MOLDED CASE CIRCUIT BREAKERS CHARACTERISTIC TRIP CURVE NO. 50-4

CIRCUIT BREAKER INFORMATION

Circuit Breaker Prefix	Continuous Ampere Rating	Maximum AC Voltage	Number of Poles
HD, HG, HJ, HL	110–150	600	2, 3

This curve is to be used for application and coordination purposes only. The **EZ-AMP** overlay feature at the bottom of the page should be used during coordination studies.

All time/current characteristic curve data is based on 40 °C ambient cold start. Terminations are made with conductors of appropriate length and ratings.

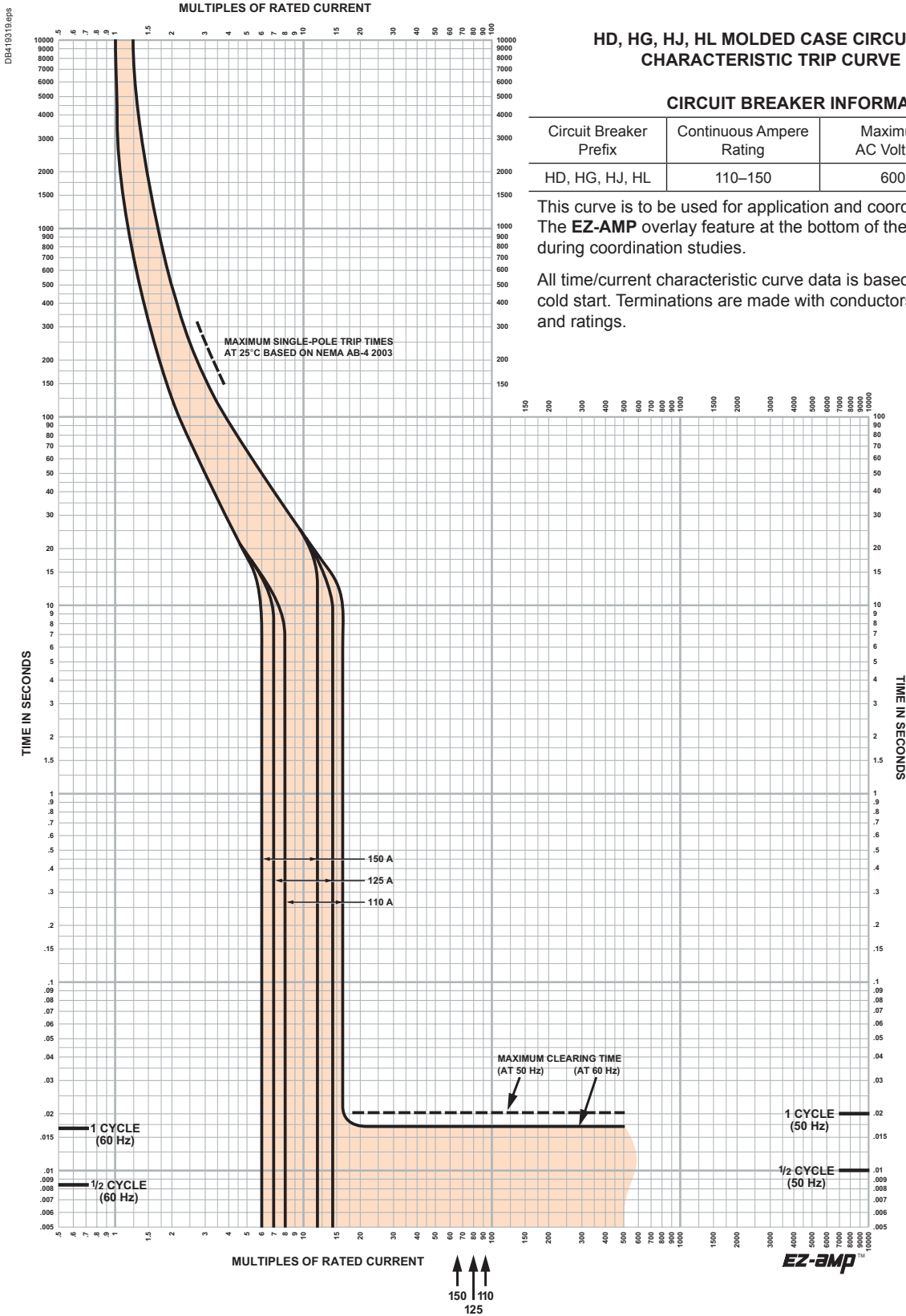

PowerPact™ H-, J-, and L-Frame Circuit Breakers

J-Frame 150–250 A (JD, JG, JJ, JL, and JR) Thermal-Magnetic Trip

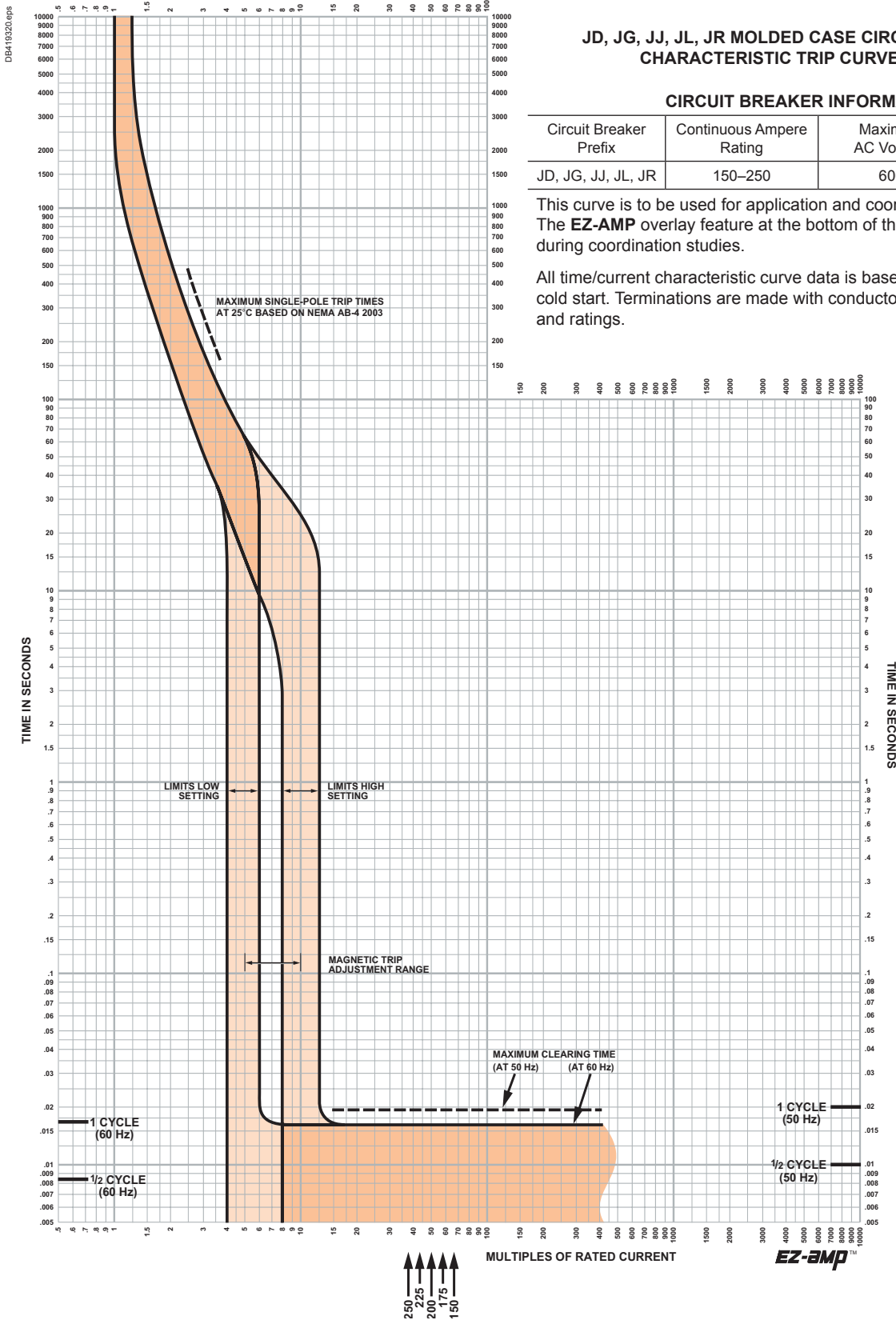

JD, JG, JJ, JL, JR MOLDED CASE CIRCUIT BREAKERS CHARACTERISTIC TRIP CURVE NO. 50-5

CIRCUIT BREAKER INFORMATION

Circuit Breaker Prefix	Continuous Ampere Rating	Maximum AC Voltage	Number of Poles
JD, JG, JJ, JL, JR	150–250	600	2, 3

This curve is to be used for application and coordination purposes only. The **EZ-AMP** overlay feature at the bottom of the page should be used during coordination studies.

All time/current characteristic curve data is based on 40 °C ambient cold start. Terminations are made with conductors of appropriate length and ratings.



H-Frame 150 A Typical Peak Let-Through Curves

ELECTRONIC MOLDED CASE CIRCUIT BREAKERS
 POWERPACT™ H-FRAME CURRENT LIMITING CIRCUIT BREAKERS
 150 A FRAME AT 240, 480 AND 600 V, 3Ø
 15-150 A

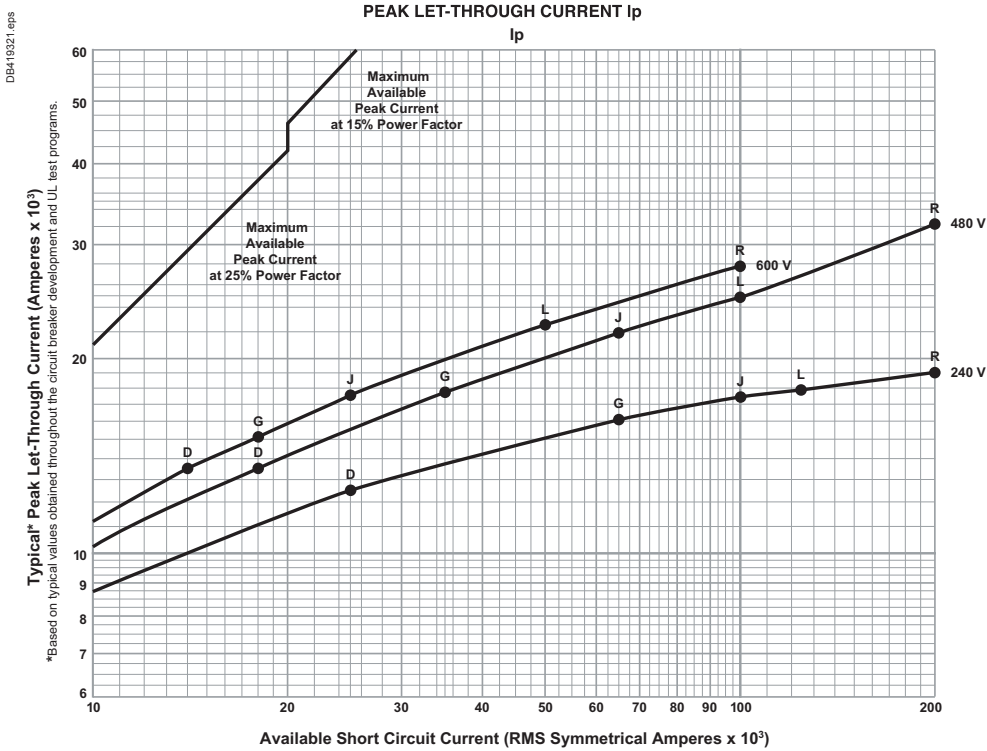

H-Frame 150 A Typical I_{2t} Let-Through Curves

ELECTRONIC MOLDED CASE CIRCUIT BREAKERS
 POWERPACT™ H-FRAME CURRENT LIMITING CIRCUIT BREAKERS
 150 A FRAME AT 240, 480 AND 600 V, 3Ø
 15-150 A

LET-THROUGH CURRENT I_{2t}

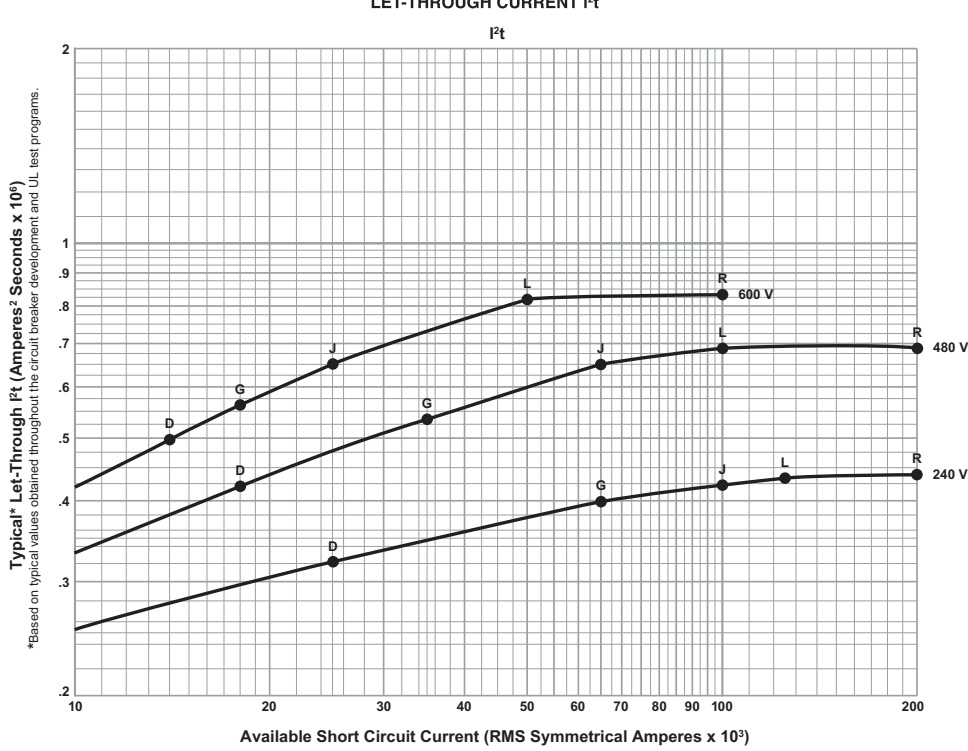

J-Frame 250 A Typical Peak Let-Through Curves

ELECTRONIC MOLDED CASE CIRCUIT BREAKERS
 POWERPACT™ J-FRAME CURRENT LIMITING CIRCUIT BREAKERS
 250 A FRAME AT 240, 480 AND 600 V, 3Ø
 15-150 A

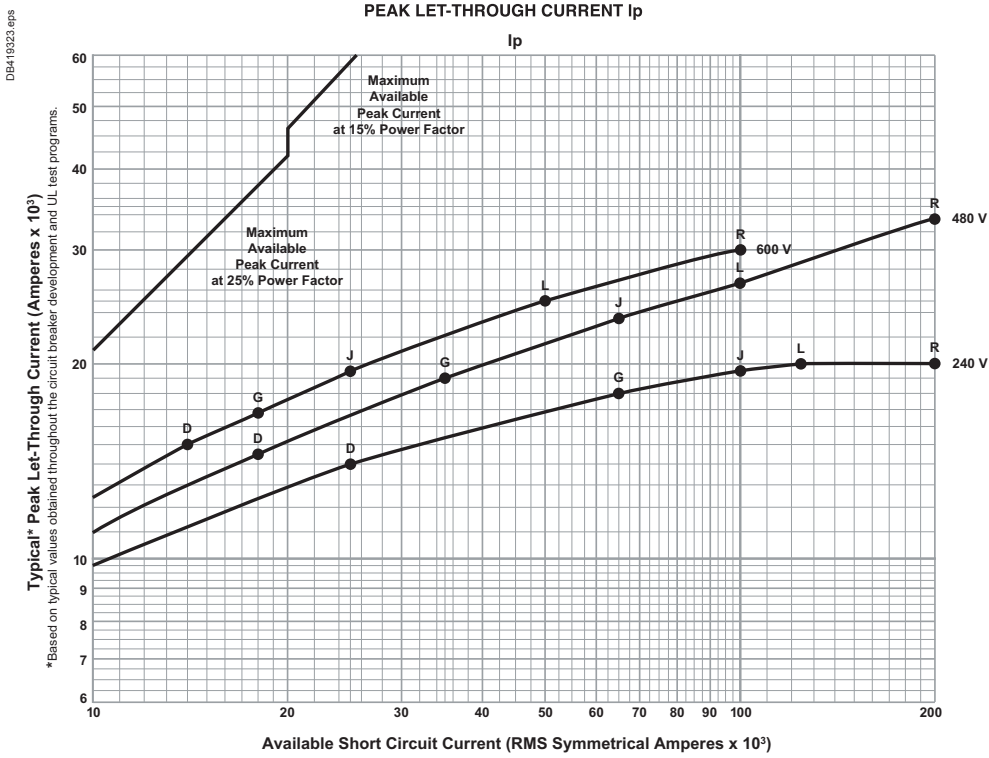

J-Frame 250 A Typical I²t Let-Through Curves

ELECTRONIC MOLDED CASE CIRCUIT BREAKERS
 POWERPACT™ J-FRAME CURRENT LIMITING CIRCUIT BREAKERS
 250 A FRAME AT 240, 480 AND 600 V, 3Ø
 150-250 A

DB419324.eps

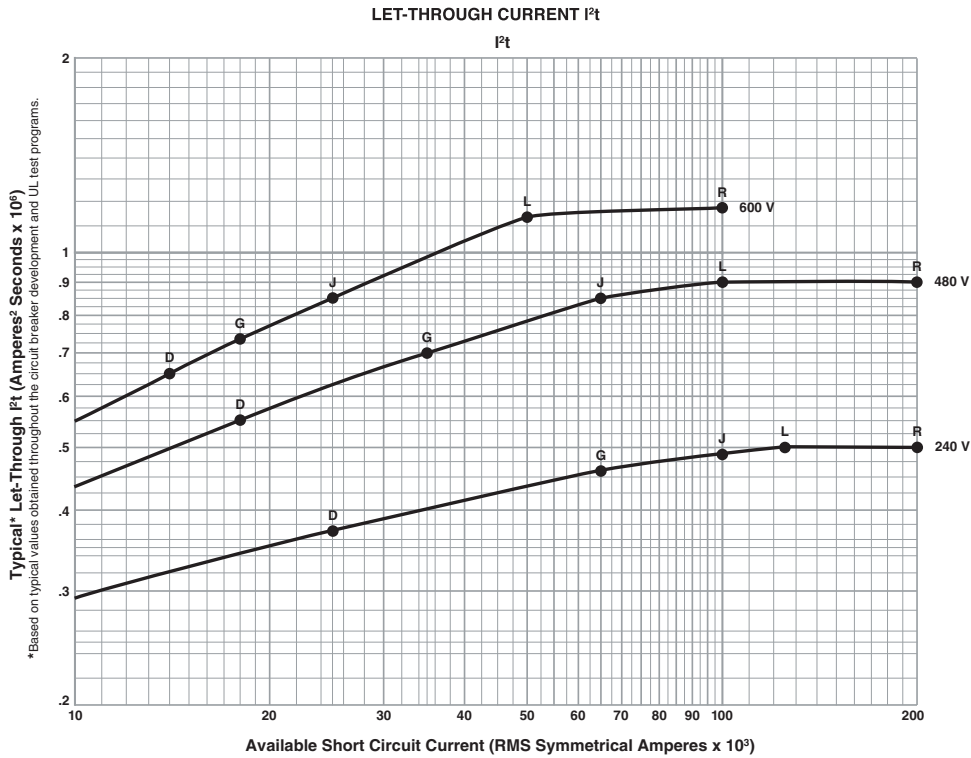

H-Frame UL Listed Current-Limiting Circuit Breaker

THERMAL-MAGNETIC MOLDED CASE CIRCUIT BREAKERS
 H-FRAME® CURRENT LIMITING CIRCUIT BREAKERS
 H 150 A FRAME AT 240, 480 AND 600 V, 3Ø
 HJ, HL AND HR 15-150 A

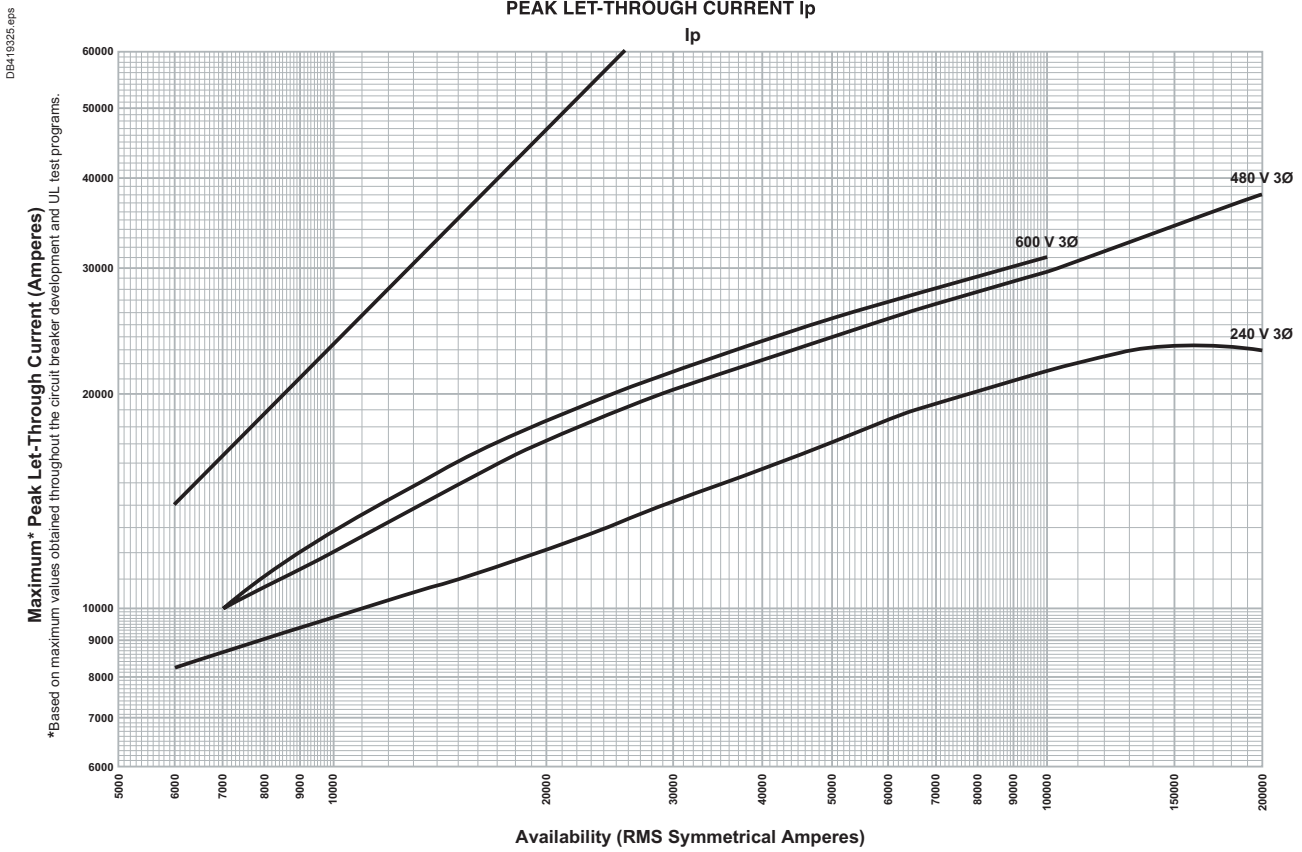

H-Frame UL Listed Current-Limiting Circuit Breaker

THERMAL-MAGNETIC MOLDED CASE CIRCUIT BREAKERS
 H-FRAME® CURRENT LIMITING CIRCUIT BREAKERS
 H 150 A FRAME AT 240, 480 AND 600 V, 3Ø
 HJ, HL AND HR 15-150 A

LET-THROUGH CURRENT I^2t

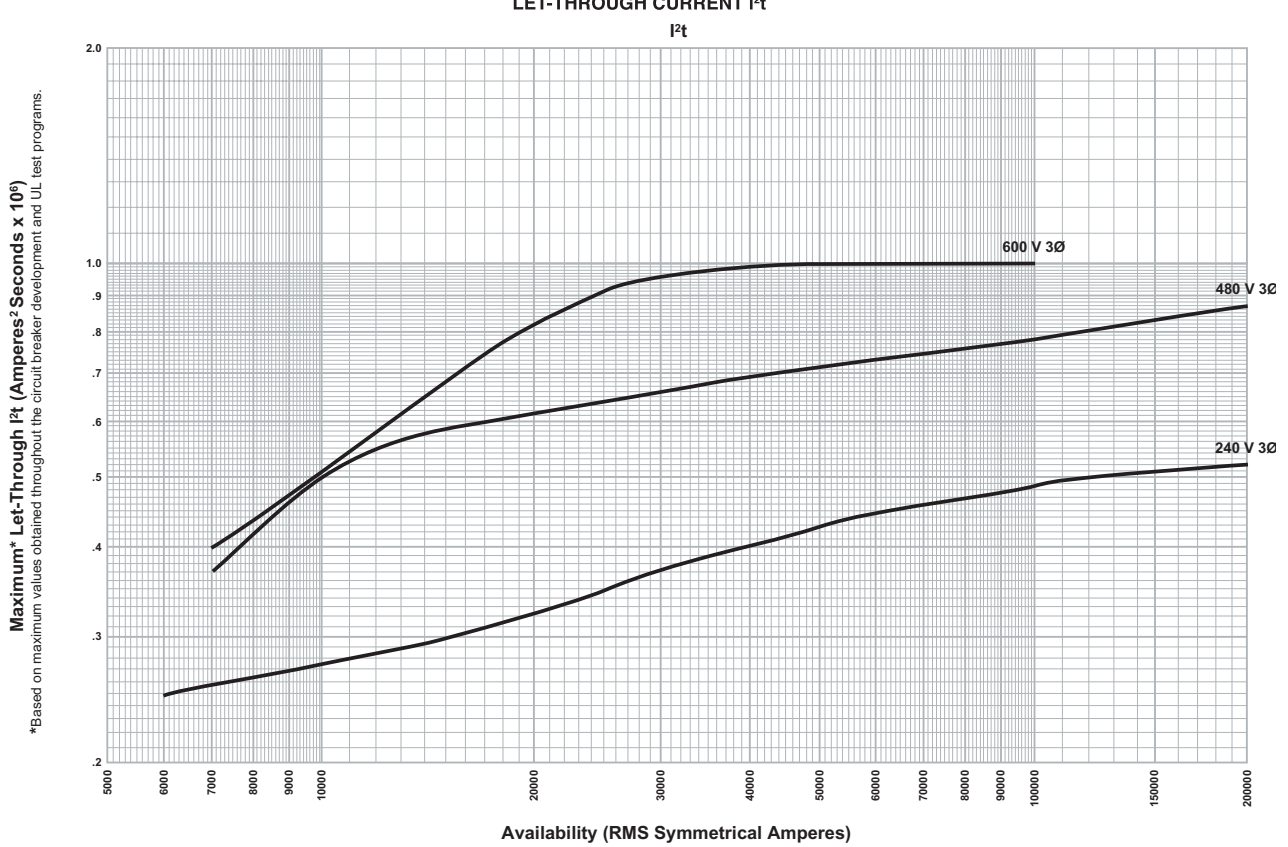

J-Frame UL Listed Current -Limiting Circuit Breaker

THERMAL-MAGNETIC MOLDED CASE CIRCUIT BREAKERS
 J-FRAME® CURRENT LIMITING CIRCUIT BREAKERS
 J 150 A FRAME AT 240, 480 AND 600 V, 3Ø
 JJ, JL AND JR 150-250 A

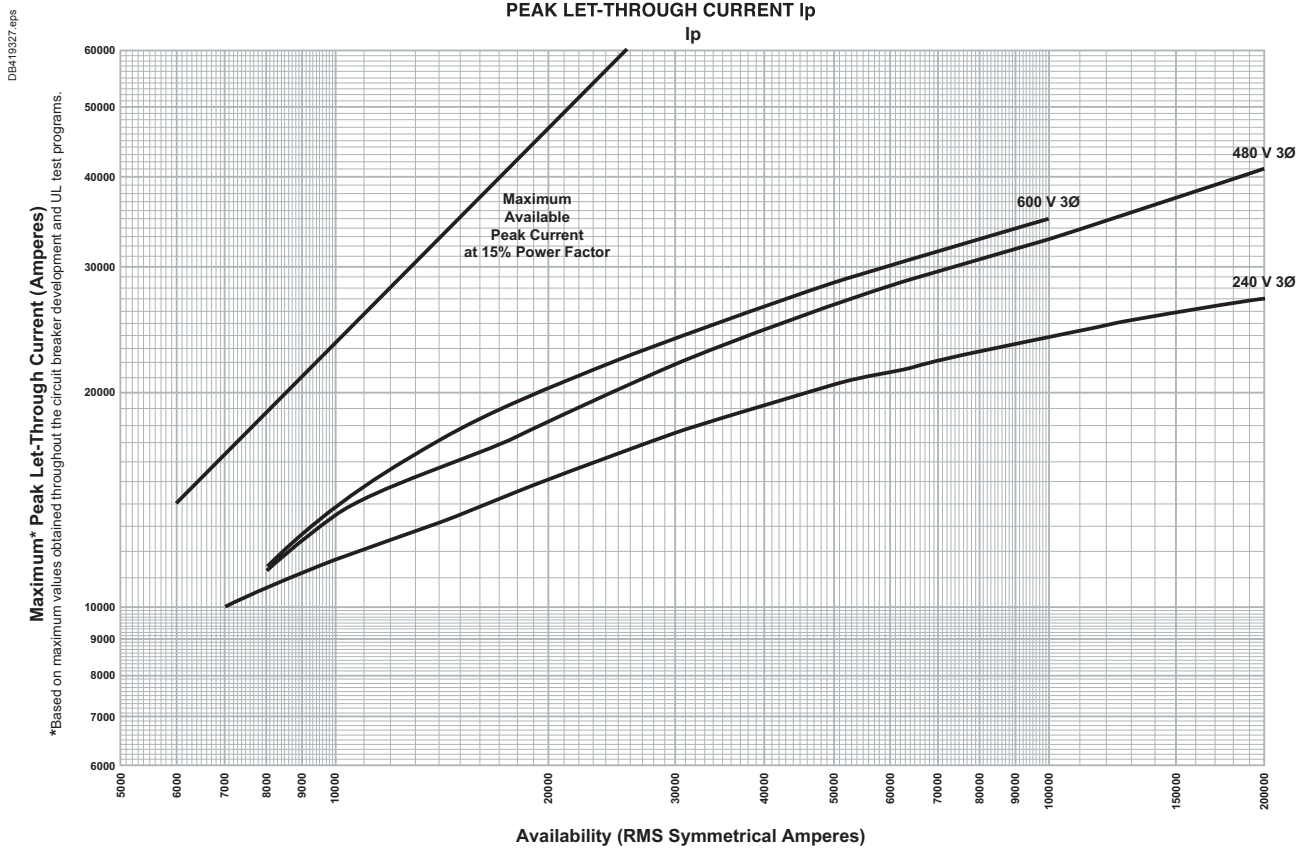

J-Frame UL Listed Current-Limiting Circuit Breaker

THERMAL-MAGNETIC MOLDED CASE CIRCUIT BREAKERS
 J-FRAME® CURRENT LIMITING CIRCUIT BREAKERS
 J 250 A FRAME AT 240, 480 AND 600 V, 3Ø
 JJ, JL AND JR 150-250 A

LET-THROUGH CURRENT I_{2t}
 I_{2t}

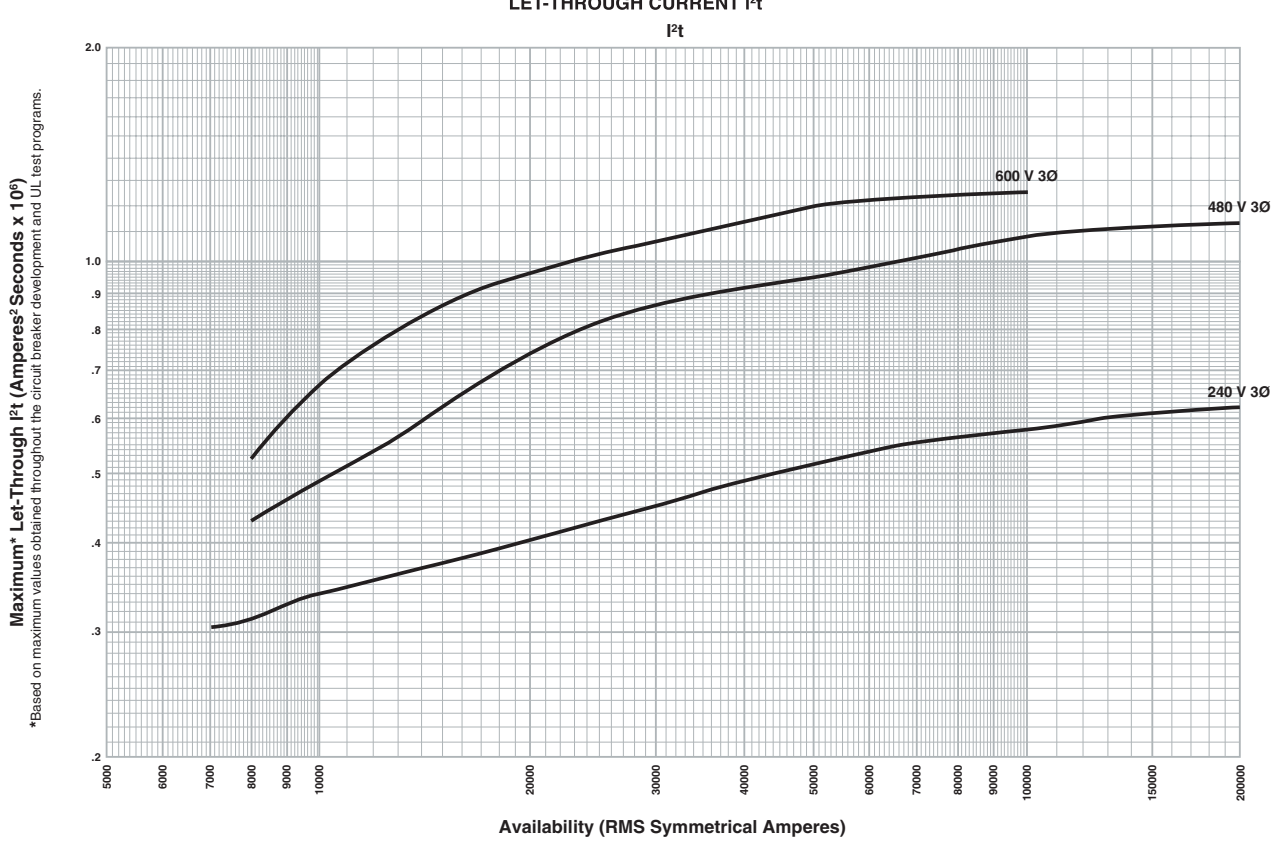

Micrologic 3.2 Electronic Trip Unit Long Time Trip Curve

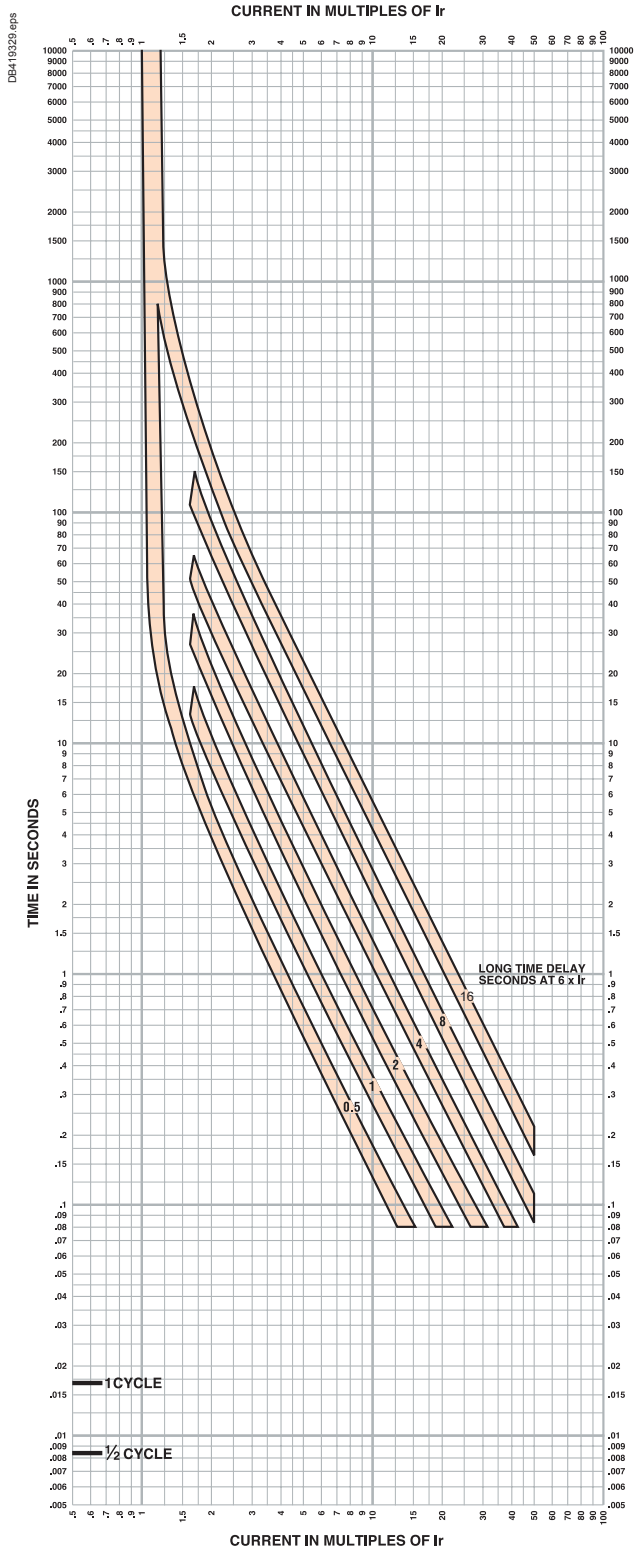

MICROLOGIC™ ELECTRONIC TRIP UNITS Micrologic™ 3.2 Long Time Trip Curve 60 A, 100 A, 150 A H-Frame

The time-current curve information is to be used for application and coordination purposes only.

(1) There is a thermal-imaging effect that can act to shorten the long-time delay. The thermal imaging effect comes into play if a current above the long-time delay pickup value exists for a time and then is cleared by the tripping of a downstream device or the circuit breaker itself. A subsequent overload will cause the circuit breaker to trip in a shorter time than normal. The amount of time delay reduction is inverse to the amount of time that has elapsed since the previous overload. Approximately 20 minutes is required between overloads to completely reset thermal-imaging.

(2) Total clearing times shown include the response times of the trip unit, the circuit breaker opening, and the extinction of the current. Curves apply from -35 °C to +70 °C (-31 °F to +158 °F) ambient temperature.

Micrologic 3.2S Electronic Trip Unit Long Time / Short Time Trip Curve

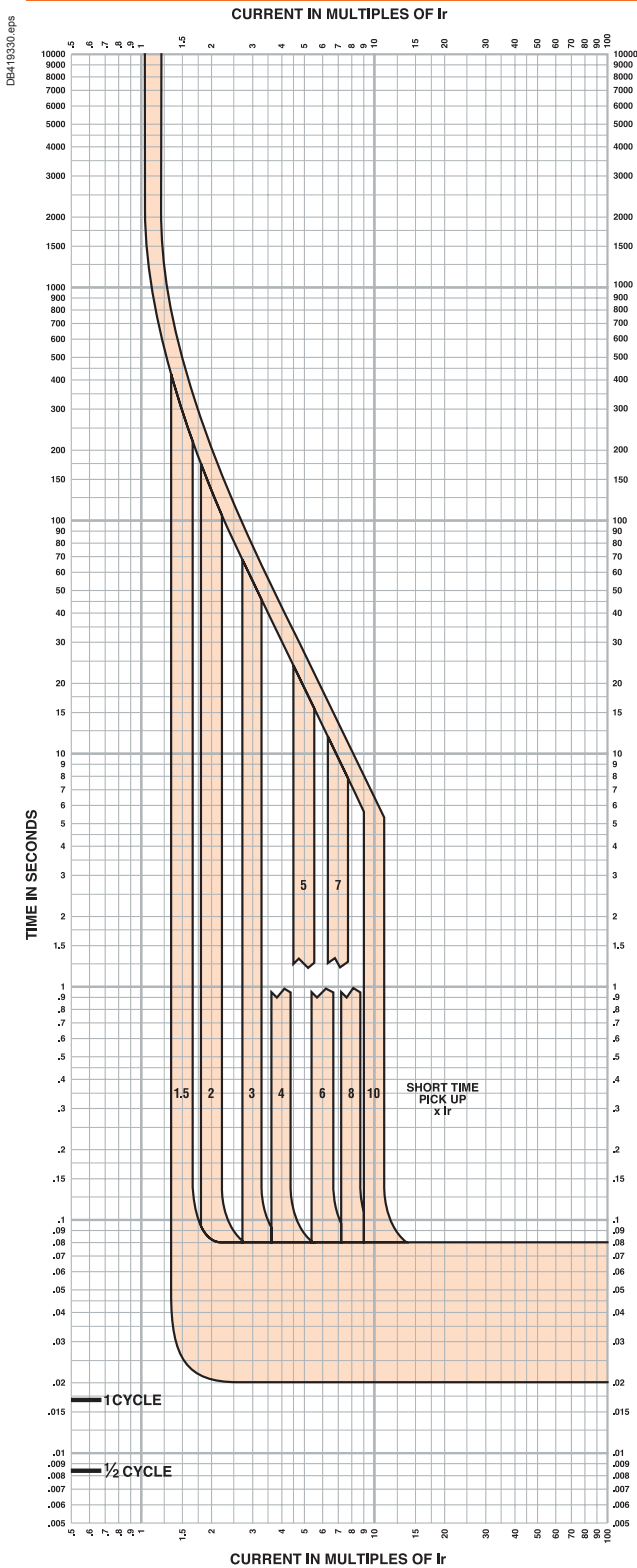

MICROLOGIC™ ELECTRONIC TRIP UNITS Micrologic™ 3.2S Long Time/ Short Time Trip Curve 60 A, 100 A, 150 A H-Frame

The time-current curve information is to be used for application and coordination purposes only.

(1) There is a thermal-imaging effect that can act to shorten the long-time delay. The thermal imaging effect comes into play if a current above the long-time delay pickup value exists for a time and then is cleared by the tripping of a downstream device or the circuit breaker itself. A subsequent overload will cause the circuit breaker to trip in a shorter time than normal. The amount of time delay reduction is inverse to the amount of time that has elapsed since the previous overload. Approximately 20 minutes is required between overloads to completely reset thermal-imaging.

(2) Total clearing times shown include the response times of the trip unit, the circuit breaker opening, and the extinction of the current. Curves apply from -35 °C to +70 °C (-31 °F to +158 °F) ambient temperature.

PowerPact™ H-, J-, and L-Frame Circuit Breakers

Micrologic 3.2/3.2S/5.2A/5.2E/6.2A/6.2E Electronic Trip Unit Instantaneous Trip Curve

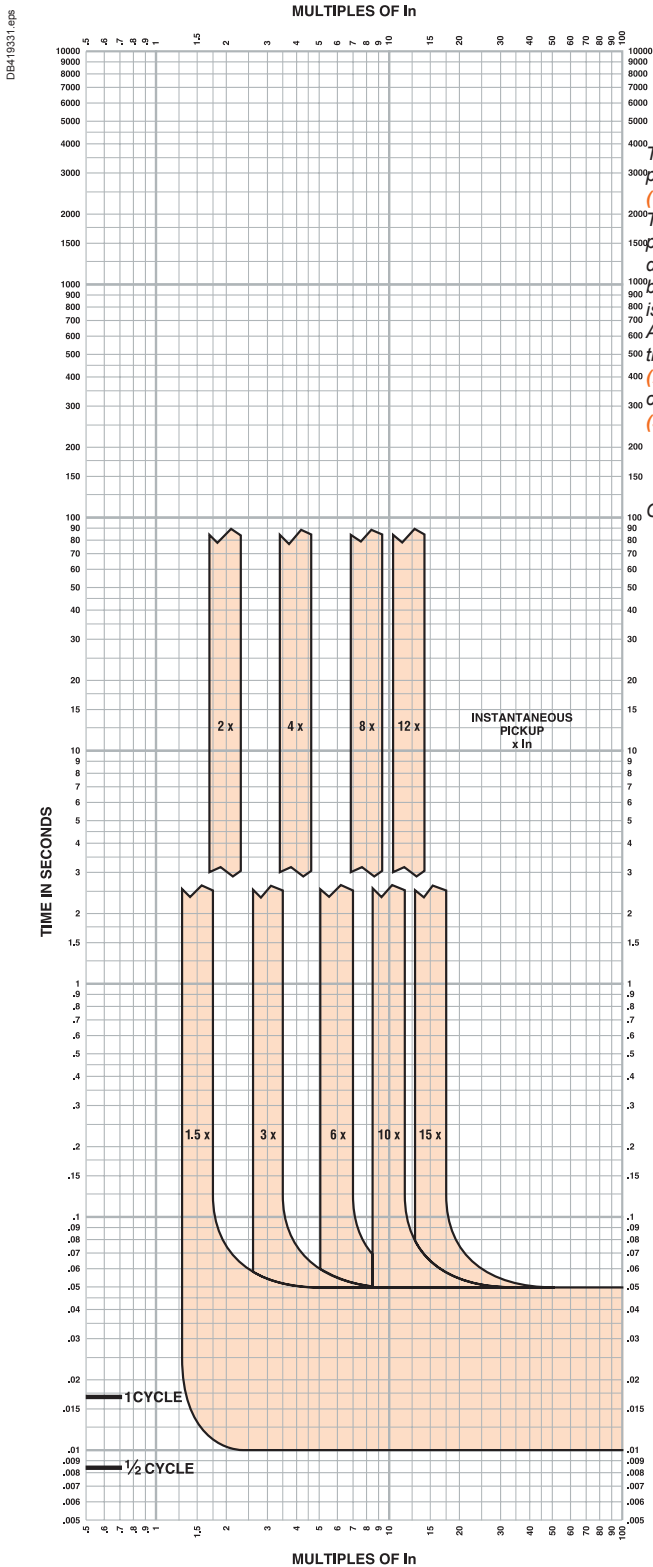

MICROLOGIC™ ELECTRONIC TRIP UNITS Micrologic™ 3.2/3.2S/5.2A or E/6.2A or E Instantaneous Trip Curve 60 A, 100 A, 150 A H-Frame

The time-current curve information is to be used for application and coordination purposes only.

(1) There is a thermal-imaging effect that can act to shorten the long-time delay. The thermal imaging effect comes into play if a current above the long-time delay pickup value exists for a time and then is cleared by the tripping of a downstream device or the circuit breaker itself. A subsequent overload will cause the circuit breaker to trip in a shorter time than normal. The amount of time delay reduction is inverse to the amount of time that has elapsed since the previous overload. Approximately 20 minutes is required between overloads to completely reset thermal-imaging.

(2) Total clearing times shown include the response times of the trip unit, the circuit breaker opening, and the extinction of the current.

(3) I_n = Maximum dial setting of I_r .
 60 A H-Frame: $I_n = 60 A = \text{Max } I_r$ setting
 100 A H-Frame: $I_n = 100 A = \text{Max } I_r$ setting
 150 A H-Frame: $I_n = 150 A = \text{Max } I_r$ setting

Curves apply from $-35\text{ }^\circ\text{C}$ to $+70\text{ }^\circ\text{C}$ ($-31\text{ }^\circ\text{F}$ to $+158\text{ }^\circ\text{F}$) ambient temperature.

Micrologic 5.2A/5.2E/6.2A/6.2E Electronic Trip Unit Long Time Trip Curve

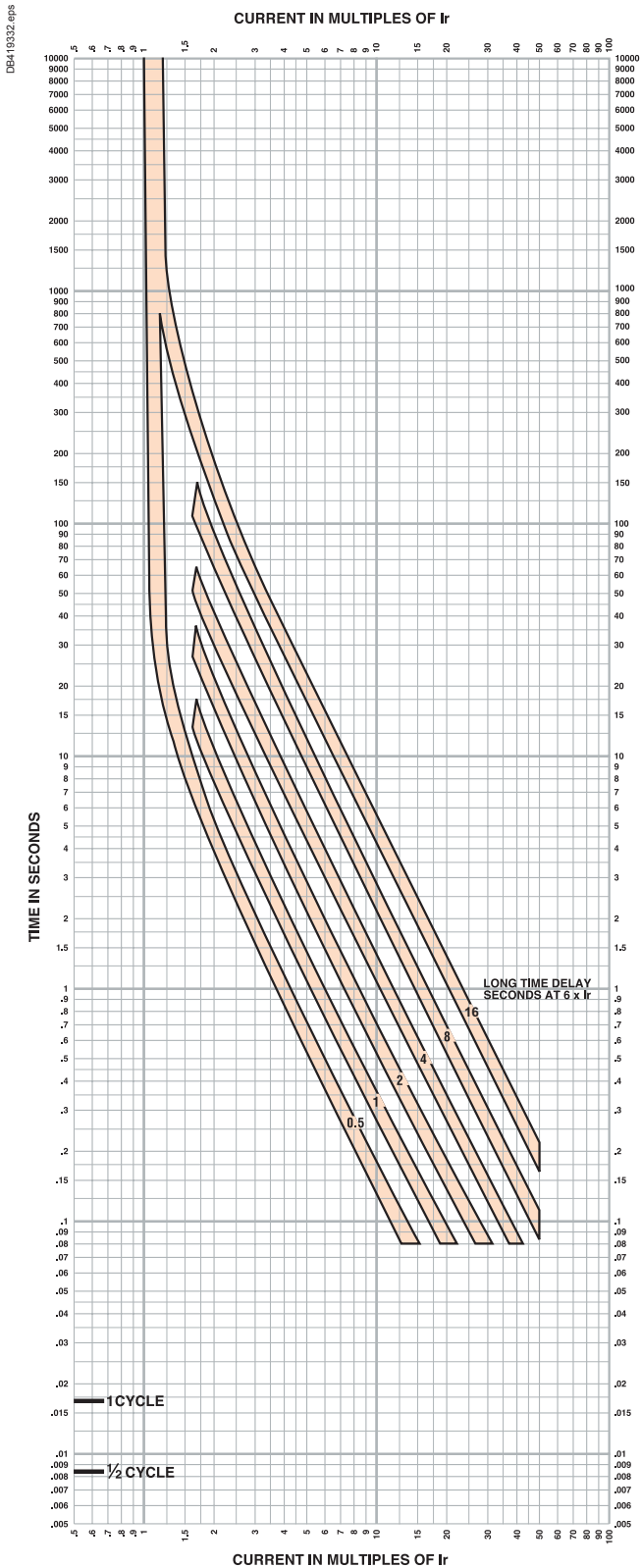

MICROLOGIC™ ELECTRONIC TRIP UNITS Micrologic™ 5.2A or E/6.2A or E Long Time Trip Curve 60 A, 100 A, 150 A H-Frame

The time-current curve information is to be used for application and coordination purposes only.

(1) There is a thermal-imaging effect that can act to shorten the long-time delay. The thermal imaging effect comes into play if a current above the long-time delay pickup value exists for a time and then is cleared by the tripping of a downstream device or the circuit breaker itself. A subsequent overload will cause the circuit breaker to trip in a shorter time than normal. The amount of time delay reduction is inverse to the amount of time that has elapsed since the previous overload. Approximately 20 minutes is required between overloads to completely reset thermal-imaging.

(2) Total clearing times shown include the response times of the trip unit, the circuit breaker opening, and the extinction of the current. Curves apply from -35 °C to +70 °C (-31 °F to +158 °F) ambient temperature.

Micrologic 5.2A/5.2E/6.2A/6.2E Electronic Trip Unit Short Time Trip Curve

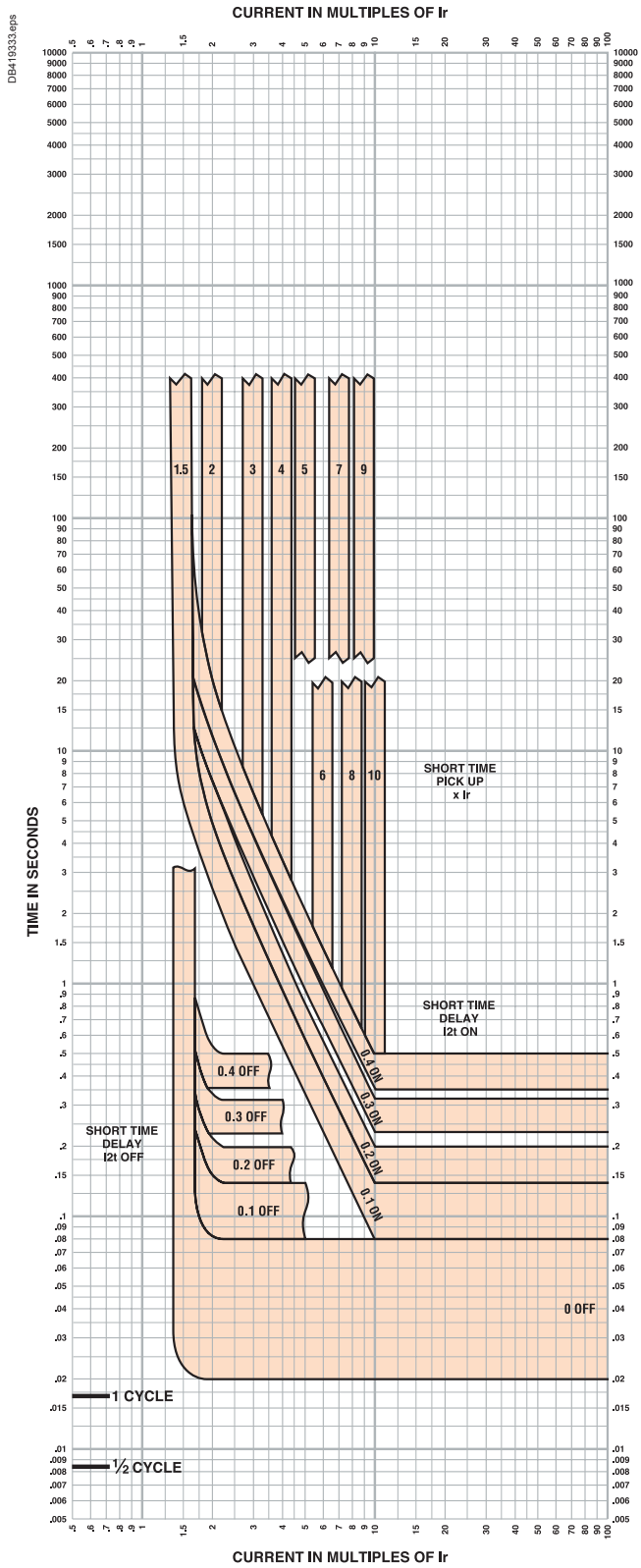

MICROLOGIC™ ELECTRONIC TRIP UNITS Micrologic™ 5.2A or E/6.2A or E Short Time Trip Curve 60 A, 100 A, 150 A H-Frame

The time-current curve information is to be used for application and coordination purposes only.

(1) There is a thermal-imaging effect that can act to shorten the long-time delay. The thermal imaging effect comes into play if a current above the long-time delay pickup value exists for a time and then is cleared by the tripping of a downstream device or the circuit breaker itself. A subsequent overload will cause the circuit breaker to trip in a shorter time than normal. The amount of time delay reduction is inverse to the amount of time that has elapsed since the previous overload. Approximately 20 minutes is required between overloads to completely reset thermal-imaging.

(2) Total clearing times shown include the response times of the trip unit, the circuit breaker opening, and the extinction of the current.

Curves apply from -35 °C to +70 °C (-31 °F to +158 °F) ambient temperature.

Micrologic 6.2A/6.2E Electronic Trip Unit Ground Fault Trip Curve

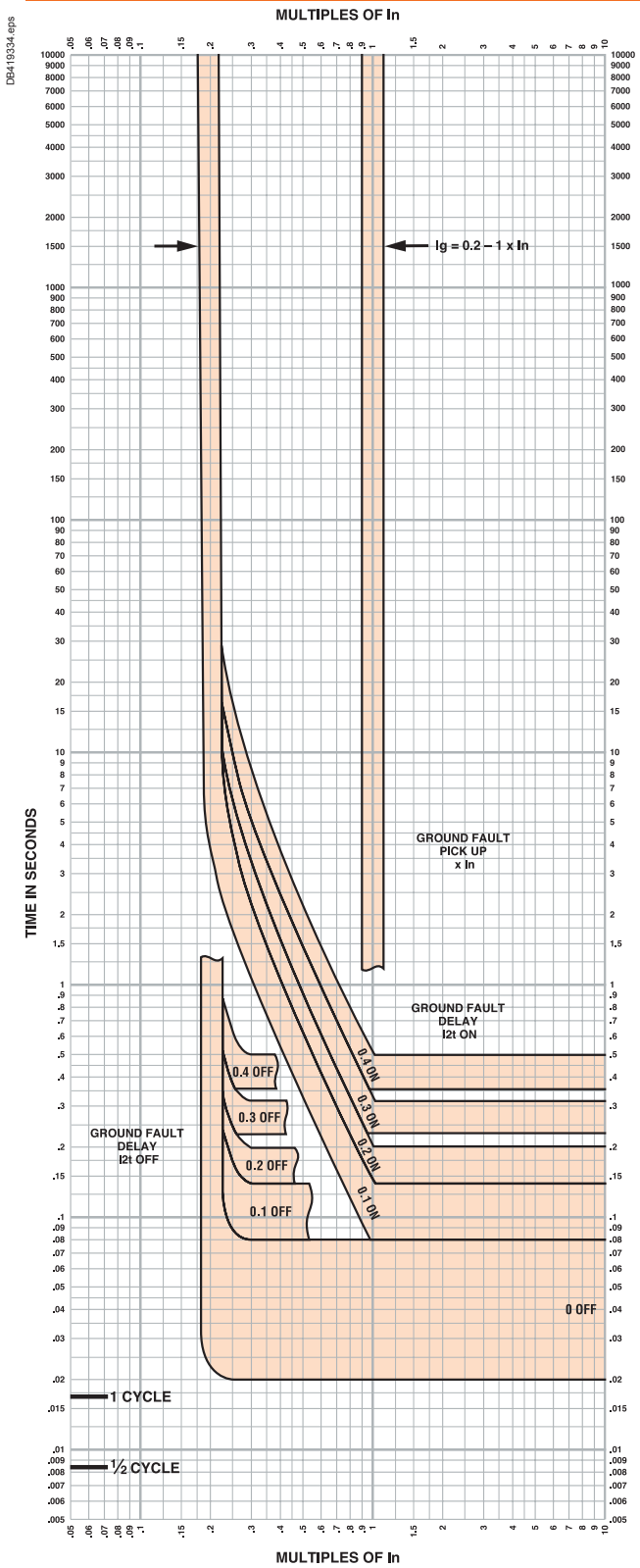

MICROLOGIC™ ELECTRONIC TRIP UNITS Micrologic™ 6.2A or E Ground Fault Trip Curve 100 A, 150 A H-Frame

The time-current curve information is to be used for application and coordination purposes only.

(1) Total clearing times shown include the response times of the trip unit, the circuit breaker opening, and the extinction of the current.
Curves apply from -35 °C to +70 °C (-31 °F to +158 °F) ambient temperature.

Micrologic 6.2A/6.2E Electronic Trip Unit Ground Fault Trip Curve

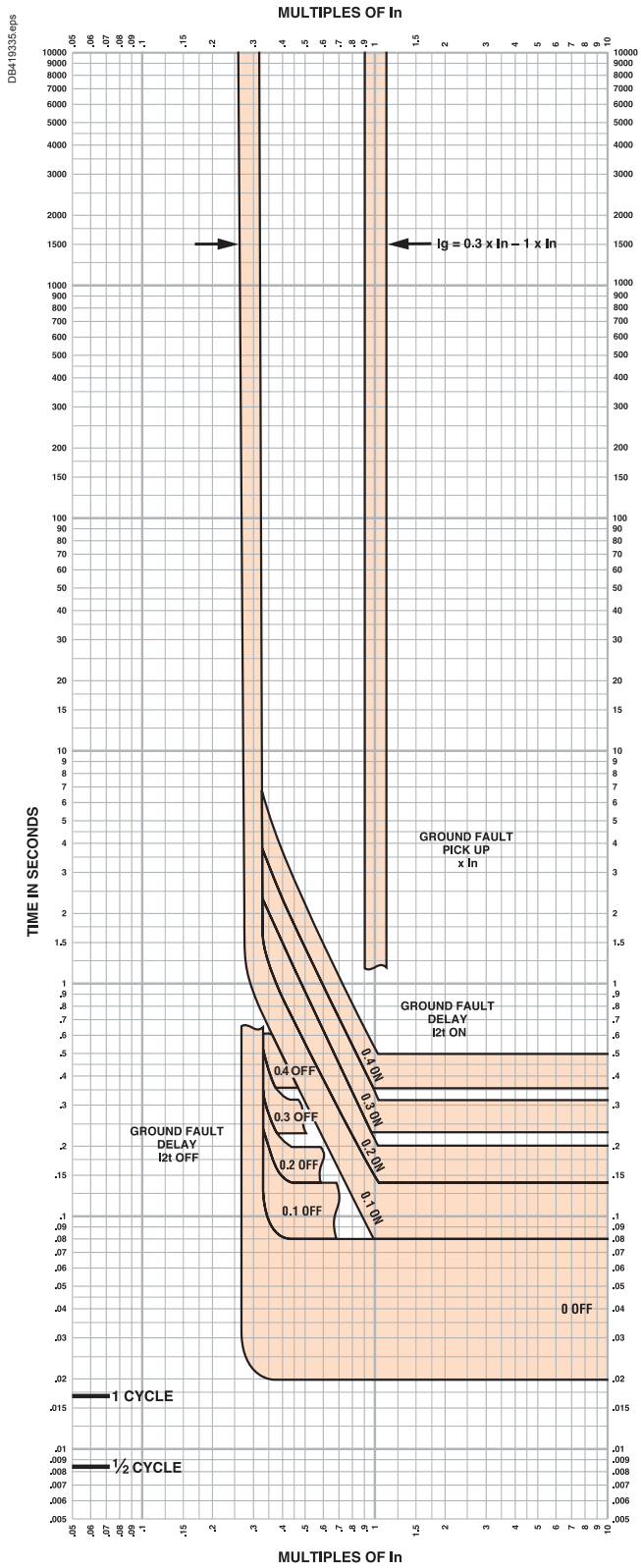

MICROLOGIC™ ELECTRONIC TRIP UNITS Micrologic™ 6.2A or E Ground Fault Trip Curve 60 A H-Frame

The time-current curve information is to be used for application and coordination purposes only.

(1) Total clearing times shown include the response times of the trip unit, the circuit breaker opening, and the extinction of the current.

Curves apply from -35 °C to +70 °C (-31 °F to +158 °F) ambient temperature.

Micrologic 2.2 M Electronic Trip Unit Overload Trip Curve

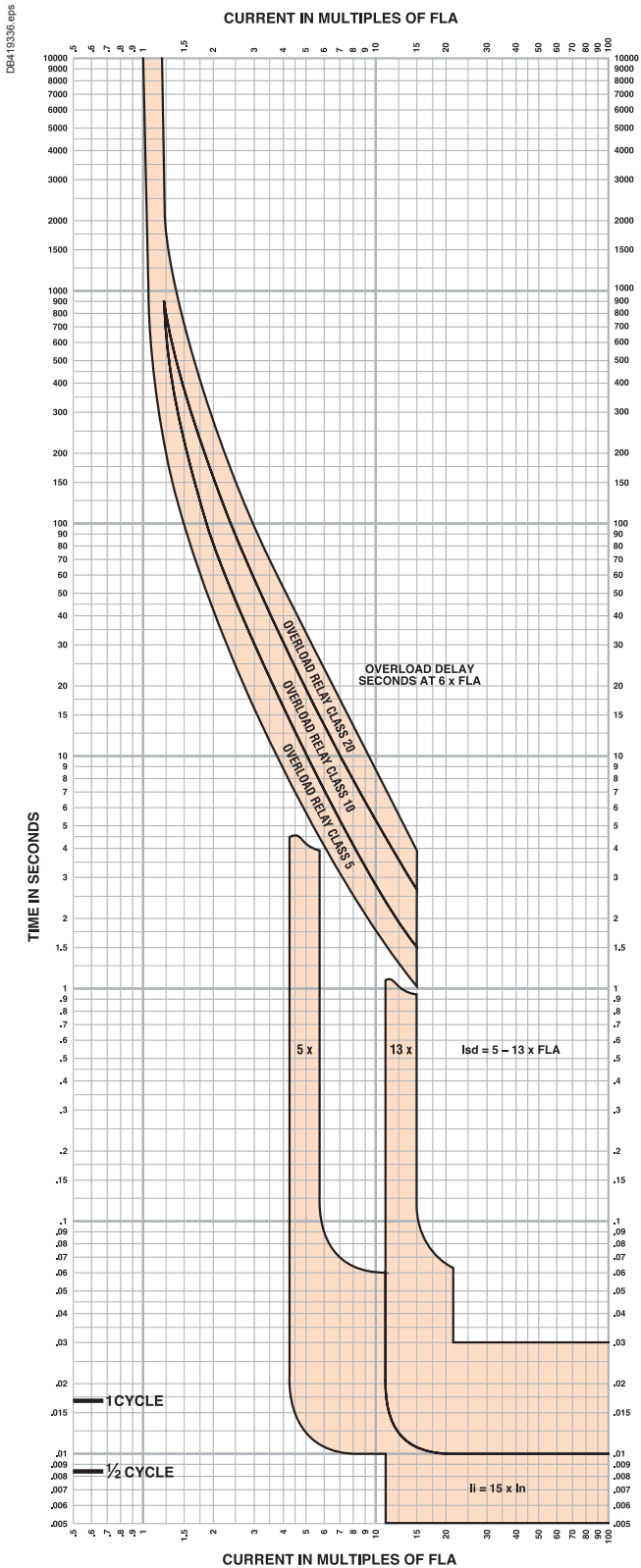

MICROLOGIC™ ELECTRONIC TRIP UNITS Micrologic™ 2.2M Overload Trip Curve 60 A, 100 A, 150 A H-Frame

The time-current curve information is to be used for application and coordination purposes only.

(1) If overload still exists past overload relay delay, MCP will open 0.4 seconds later.

(2) Total clearing times shown include the response times of the trip unit, the circuit breaker opening, and the extinction of the current.

(3) Isd minimum and maximum only shown.

(4) $li = 15 \times In$

$In = 30 A, 50 A, 100 A, 150 A, 250 A$

MCP will trip < 30 ms at $15 \times In$

Curves apply from $-35\text{ }^{\circ}\text{C}$ to $+70\text{ }^{\circ}\text{C}$ ($-31\text{ }^{\circ}\text{F}$ to $+158\text{ }^{\circ}\text{F}$) ambient temperature.

Micrologic 3.2 and 3.2-W Electronic Trip Unit Long-Time Trip Curve

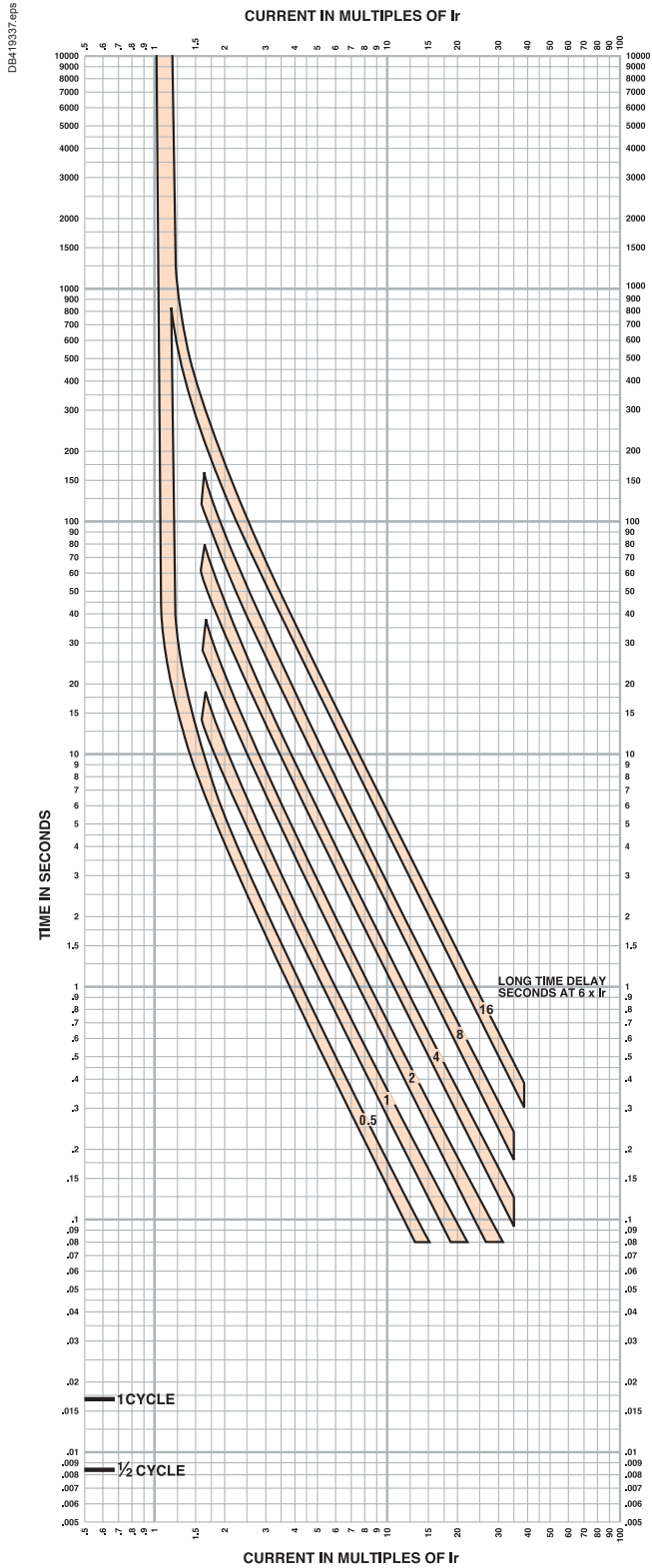

MICROLOGIC™ ELECTRONIC TRIP UNITS Micrologic™ 3.2 and 3.2-W Long Time Trip Curve 250 A J-Frame

The time-current curve information is to be used for application and coordination purposes only.

(1) There is a thermal-imaging effect that can act to shorten the long-time delay. The thermal imaging effect comes into play if a current above the long-time delay pickup value exists for a time and then is cleared by the tripping of a downstream device or the circuit breaker itself. A subsequent overload will cause the circuit breaker to trip in a shorter time than normal. The amount of time delay reduction is inverse to the amount of time that has elapsed since the previous overload. Approximately 20 minutes is required between overloads to completely reset thermal-imaging.

(2) Total clearing times shown include the response times of the trip unit, the circuit breaker opening, and the extinction of the current. Curves apply from -35 °C to +70 °C (-31 °F to +158 °F) ambient temperature.

Micrologic 3.2S and 3.2S-W Electronic Trip Unit Long Time / Short Time Trip Curve

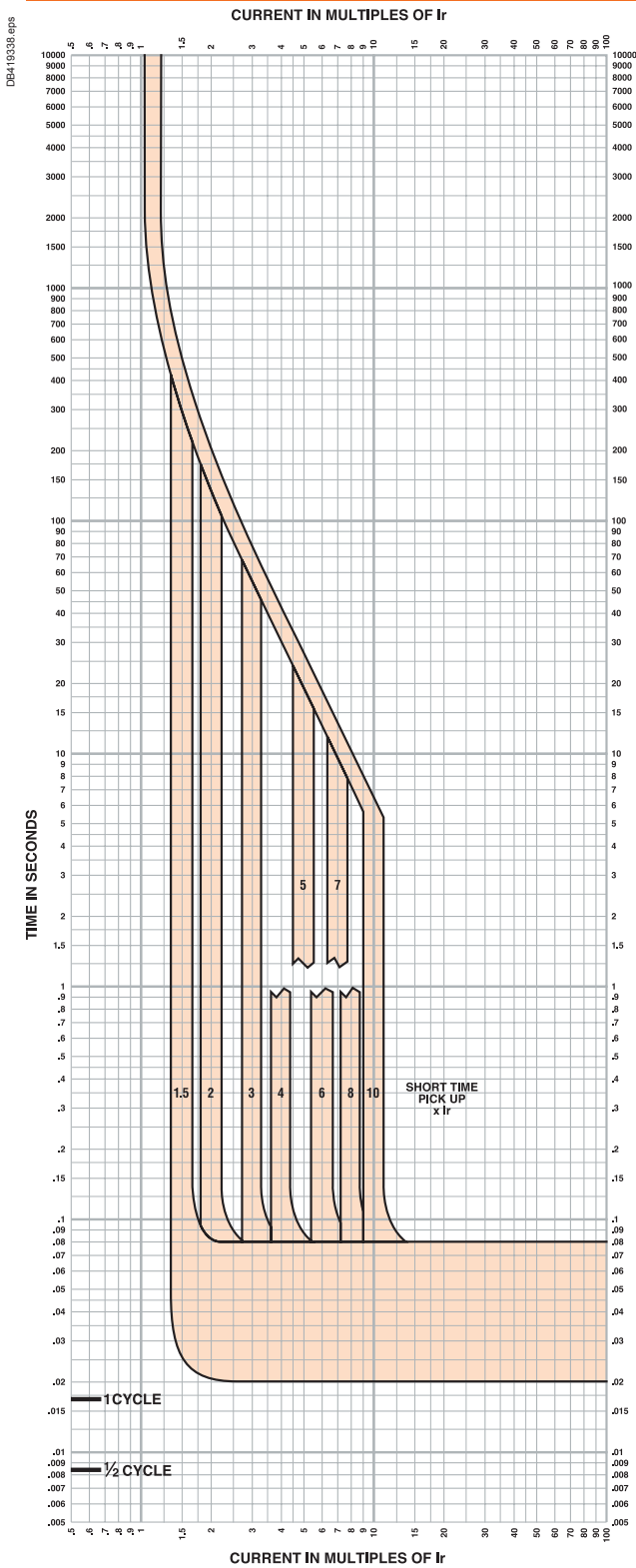

MICROLOGIC™ ELECTRONIC TRIP UNITS Micrologic™ 3.2S and 3.2S-W Long Time/Short Time Trip Curve 250 A J-Frame

The time-current curve information is to be used for application and coordination purposes only.

(1) There is a thermal-imaging effect that can act to shorten the long-time delay. The thermal imaging effect comes into play if a current above the long-time delay pickup value exists for a time and then is cleared by the tripping of a downstream device or the circuit breaker itself. A subsequent overload will cause the circuit breaker to trip in a shorter time than normal. The amount of time delay reduction is inverse to the amount of time that has elapsed since the previous overload. Approximately 20 minutes is required between overloads to completely reset thermal-imaging.

(2) Total clearing times shown include the response times of the trip unit, the circuit breaker opening, and the extinction of the current. Curves apply from -35 °C to +70 °C (-31 °F to +158 °F) ambient temperature.

PowerPact™ H-, J-, and L-Frame Circuit Breakers

Micrologic 3.2, 3.2-W, 3.2S, 3.2S-W, 5.2A, 5.2A-W, 5.2E, 5.2E-W, 6.2A, 6.2A-W, 6.2E, and 6.2E-W Electronic Trip Curve Instantaneous Trip Curve

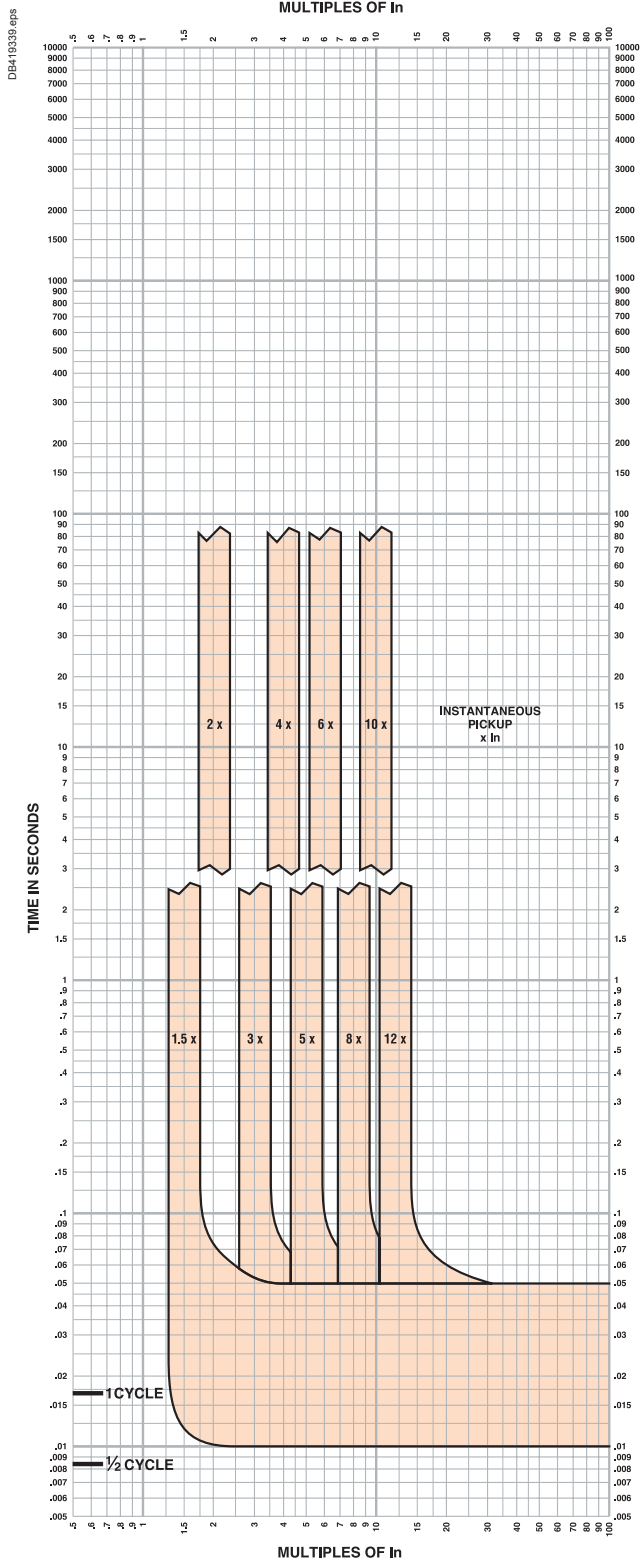

MICROLOGIC™ ELECTRONIC TRIP UNITS Micrologic™ 3.2, 3.2-W, 3.2S, 3.2S-W, 5.2A, 5.2A-W, 5.2E, 5.2E-W, 6.2A, 6.2A-W, 6.2E, and 6.2E-W Instantaneous Trip Curve 250 A J-Frame

The time-current curve information is to be used for application and coordination purposes only.

(1) There is a thermal-imaging effect that can act to shorten the long-time delay. The thermal imaging effect comes into play if a current above the long-time delay pickup value exists for a time and then is cleared by the tripping of a downstream device or the circuit breaker itself. A subsequent overload will cause the circuit breaker to trip in a shorter time than normal. The amount of time delay reduction is inverse to the amount of time that has elapsed since the previous overload. Approximately 20 minutes is required between overloads to completely reset thermal-imaging.

(2) Total clearing times shown include the response times of the trip unit, the circuit breaker opening, and the extinction of the current.

(3) I_n = Maximum dial setting of I_r .

250 A J-Frame: $I_n = 250 \text{ A} = \text{Max } I_r \text{ setting}$

Curves apply from $-35 \text{ }^\circ\text{C}$ to $+70 \text{ }^\circ\text{C}$ ($-31 \text{ }^\circ\text{F}$ to $+158 \text{ }^\circ\text{F}$) ambient temperature.

Micrologic 5.2A, 5.2A-W, 5.2E, 5.2E-W, 6.2A, 6.2A-W, 6.2E, and 6.2E-W Electronic Trip Unit Long Time Trip Curve

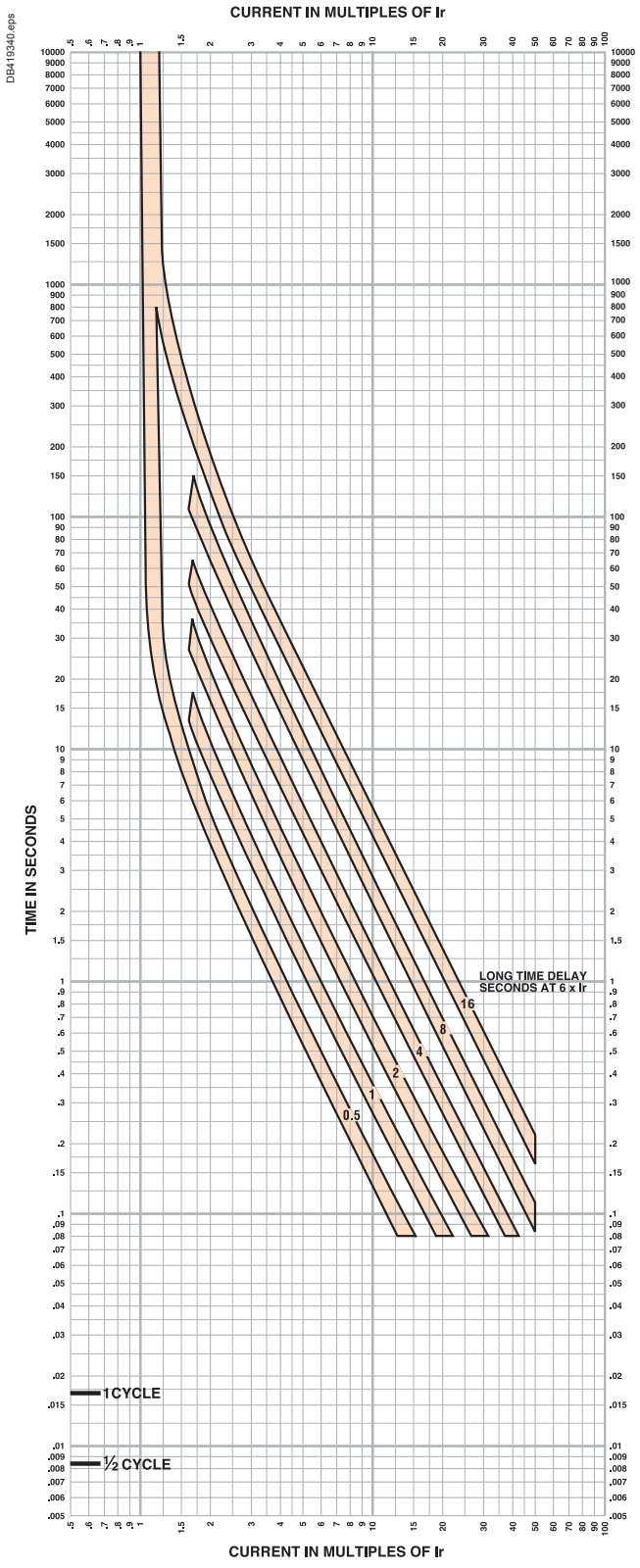

MICROLOGIC™ ELECTRONIC TRIP UNITS
Micrologic™ 5.2A, 5.2A-W, 5.2E, 5.2E-W, 6.2A,
6.2A-W, 6.2E, and 6.2E-W
Long Time Trip Curve
250 A J-Frame

The time-current curve information is to be used for application and coordination purposes only.

(1) There is a thermal-imaging effect that can act to shorten the long-time delay. The thermal imaging effect comes into play if a current above the long-time delay pickup value exists for a time and then is cleared by the tripping of a downstream device or the circuit breaker itself. A subsequent overload will cause the circuit breaker to trip in a shorter time than normal. The amount of time delay reduction is inverse to the amount of time that has elapsed since the previous overload. Approximately 20 minutes is required between overloads to completely reset thermal-imaging.

(2) Total clearing times shown include the response times of the trip unit, the circuit breaker opening, and the extinction of the current. Curves apply from -35 °C to +70 °C (-31 °F to +158 °F) ambient temperature.

PowerPact™ H-, J-, and L-Frame Circuit Breakers

Micrologic 5.2A, 5.2A-W, 5.2E, 5.2E-W, 6.2A, 6.2A-W, 6.2E, and 6.2E-W Electronic Trip Unit Short Time Trip Curve

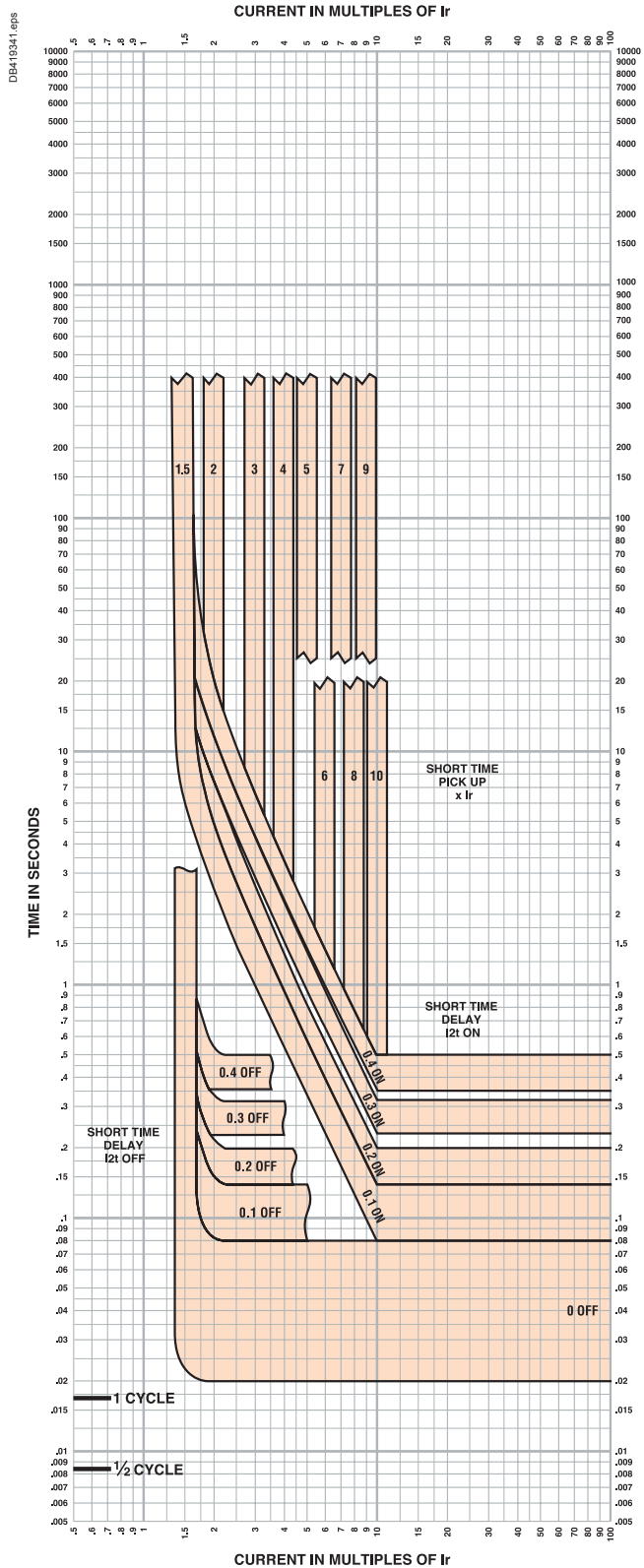

MICROLOGIC™ ELECTRONIC TRIP UNITS
Micrologic™ 5.2A, 5.2A-W, 5.2E, 5.2E-W, 6.2A,
6.2A-W, 6.2E, and 6.2E-W
Short Time Trip Curve
250 A J-Frame

The time-current curve information is to be used for application and coordination purposes only.

(1) There is a thermal-imaging effect that can act to shorten the long-time delay. The thermal imaging effect comes into play if a current above the long-time delay pickup value exists for a time and then is cleared by the tripping of a downstream device or the circuit breaker itself. A subsequent overload will cause the circuit breaker to trip in a shorter time than normal. The amount of time delay reduction is inverse to the amount of time that has elapsed since the previous overload. Approximately 20 minutes is required between overloads to completely reset thermal-imaging.

(2) Total clearing times shown include the response times of the trip unit, the circuit breaker opening, and the extinction of the current. Curves apply from -35 °C to +70 °C (-31 °F to +158 °F) ambient temperature.

Micrologic 6.2A, 6.2A-W, 6.2E, and 6.2E-W Electronic Trip Unit Ground Fault Trip Curve

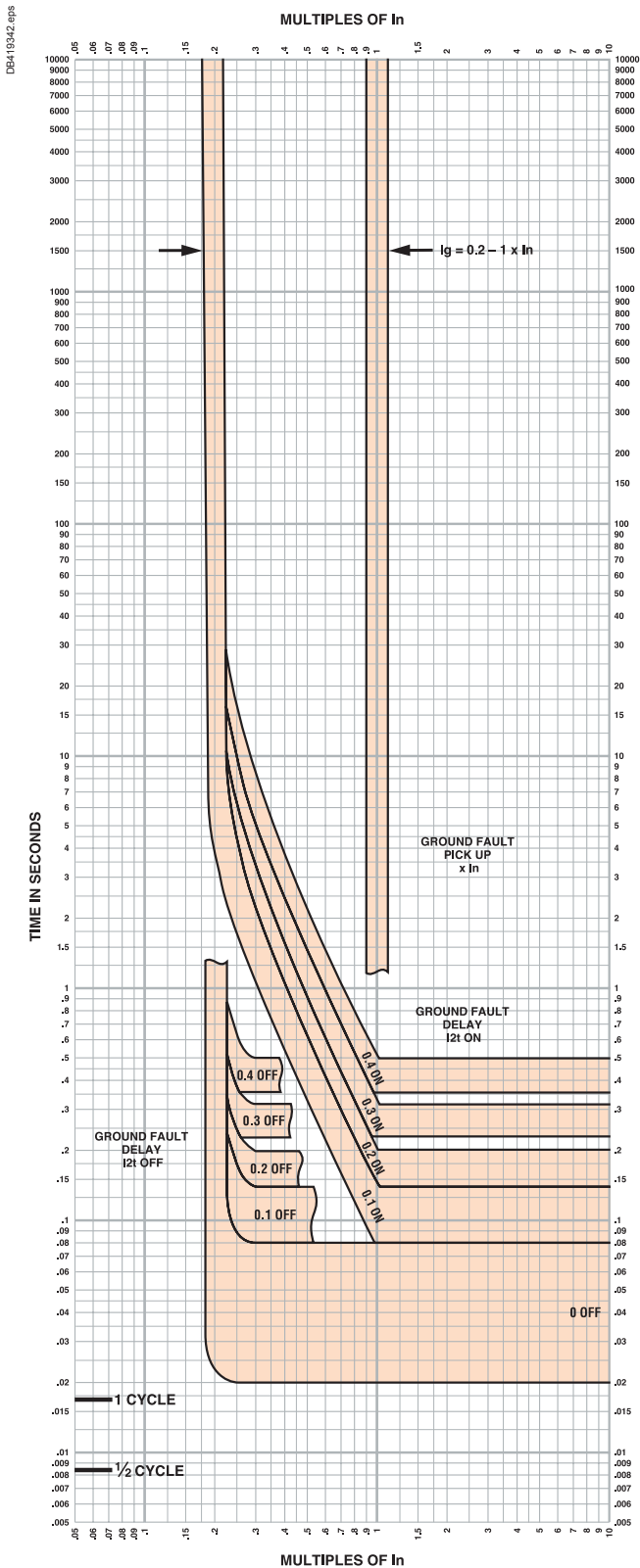

MICROLOGIC™ ELECTRONIC TRIP UNITS Micrologic™ 6.2A, 6.2A-W, 6.2E, and 6.2E-W Ground Fault Trip Curve 250 A J-Frame

The time-current curve information is to be used for application and coordination purposes only.

(1) Total clearing times shown include the response times of the trip unit, the circuit breaker opening, and the extinction of the current.
Curves apply from -35 °C to +70 °C (-31 °F to +158 °F) ambient temperature.

Micrologic 2.2 M Electronic Trip Unit Overload Trip Curve

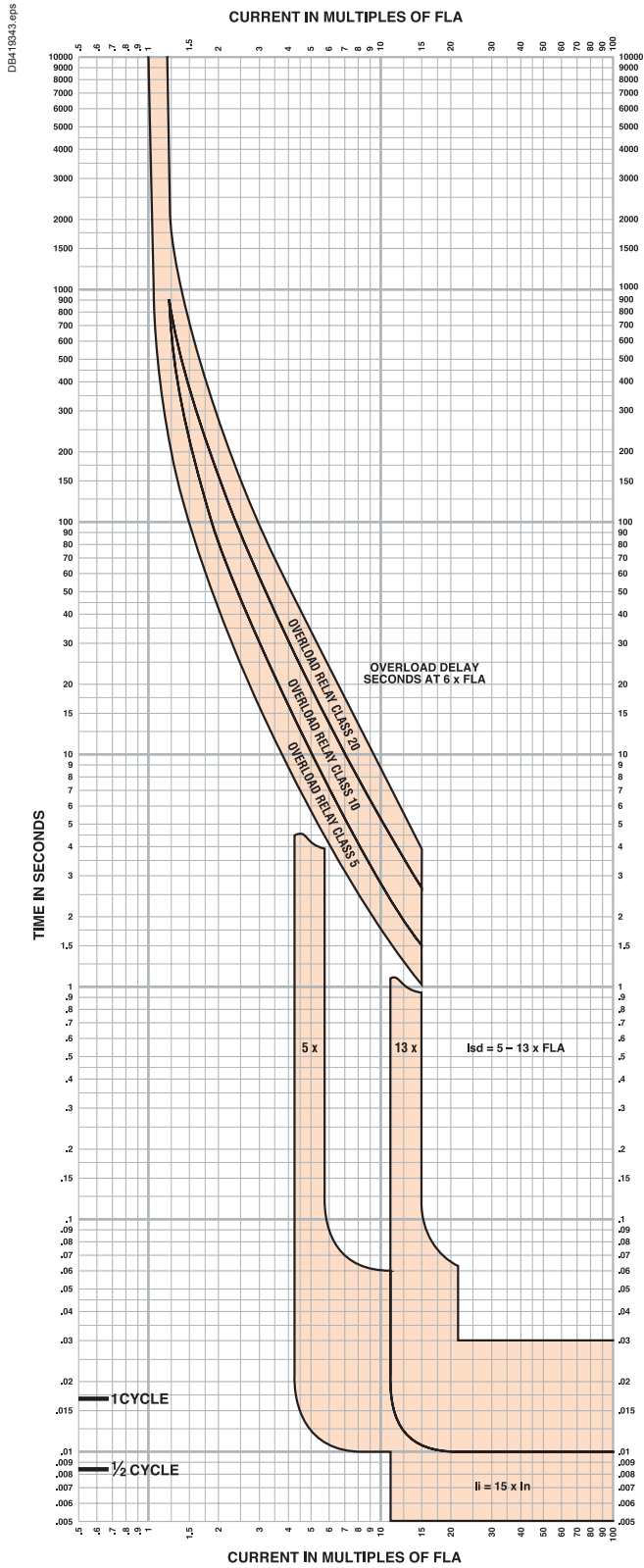

The time-current curve information is to be used for application and coordination purposes only.

(1) If overload still exists past overload relay delay, MCP will open 0.4 seconds later.

(2) Total clearing times shown include the response times of the trip unit, the circuit breaker opening, and the extinction of the current.

(3) Isd minimum and maximum only shown.

(4) $I_i = 15 \times I_n$

$I_n = 30 \text{ A}, 50 \text{ A}, 100 \text{ A}, 150 \text{ A}, 250 \text{ A}$

MCP will trip < 30 ms at $15 \times I_n$

Curves apply from $-35 \text{ }^\circ\text{C}$ to $+70 \text{ }^\circ\text{C}$ ($-31 \text{ }^\circ\text{F}$ to $+158 \text{ }^\circ\text{F}$) ambient temperature.

Micrologic 3.3 and 3.3-W Electronic Trip Unit Long Time Trip Curve

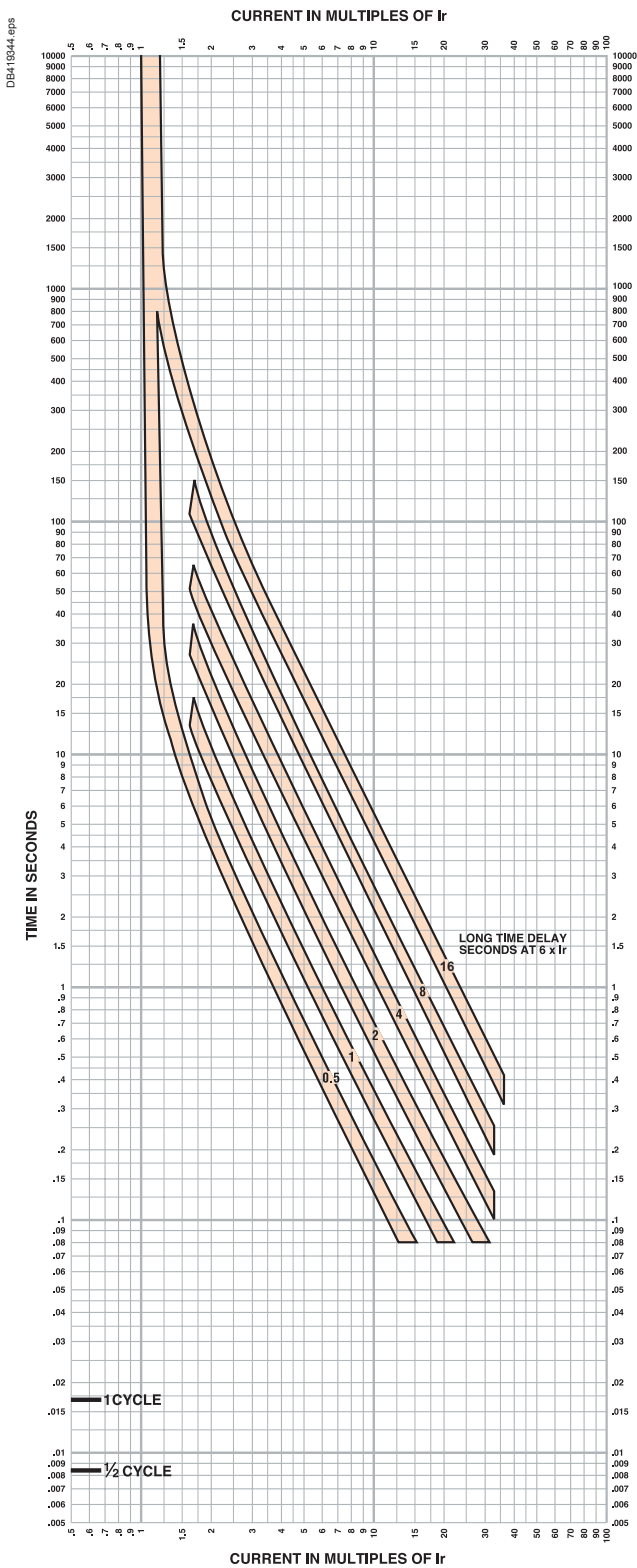

MICROLOGIC™ ELECTRONIC TRIP UNITS Micrologic™ 3.3 and 3.3-W Long Time Trip Curve 250 A, 400 A L-Frame

The time-current curve information is to be used for application and coordination purposes only.

(1) There is a thermal-imaging effect that can act to shorten the long-time delay. The thermal imaging effect comes into play if a current above the long-time delay pickup value exists for a time and then is cleared by the tripping of a downstream device or the circuit breaker itself. A subsequent overload will cause the circuit breaker to trip in a shorter time than normal. The amount of time delay reduction is inverse to the amount of time that has elapsed since the previous overload. Approximately 20 minutes is required between overloads to completely reset thermal-imaging.

(2) Total clearing times shown include the response times of the trip unit, the circuit breaker opening, and the extinction of the current. Curves apply from -35 °C to +70 °C (-31 °F to +158 °F) ambient temperature.

PowerPact™ H-, J-, and L-Frame Circuit Breakers

Micrologic 2.2 M Electronic Trip Unit Overload Trip Curve

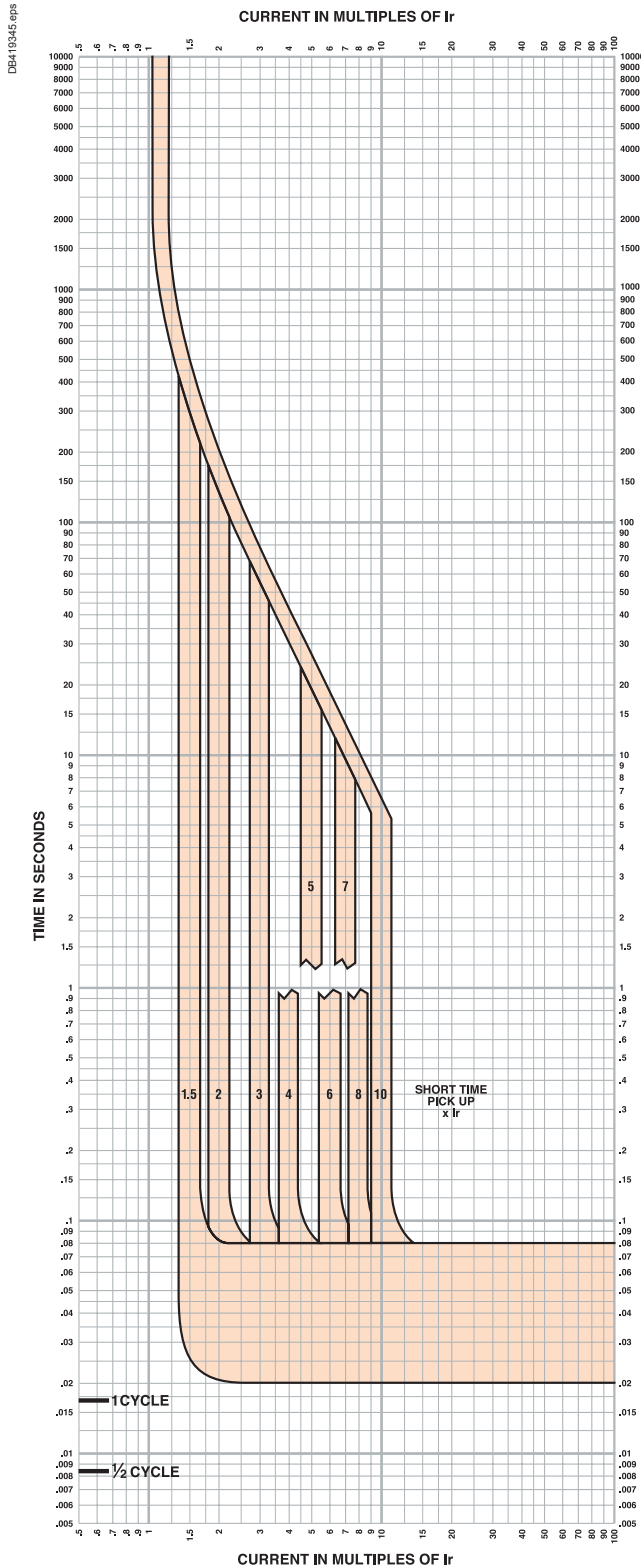

MICROLOGIC™ ELECTRONIC TRIP UNITS Micrologic™ 3.3S and 3.3S-W Long Time/Short Time Trip Curve 250 A, 400 A L-Frame

The time-current curve information is to be used for application and coordination purposes only.

(1) There is a thermal-imaging effect that can act to shorten the long-time delay. The thermal imaging effect comes into play if a current above the long-time delay pickup value exists for a time and then is cleared by the tripping of a downstream device or the circuit breaker itself. A subsequent overload will cause the circuit breaker to trip in a shorter time than normal. The amount of time delay reduction is inverse to the amount of time that has elapsed since the previous overload. Approximately 20 minutes is required between overloads to completely reset thermal-imaging.

(2) Total clearing times shown include the response times of the trip unit, the circuit breaker opening, and the extinction of the current. Curves apply from -35 °C to +70 °C (-31 °F to +158 °F) ambient temperature.

Micrologic 3.3, 3.3-W, 3.3S, and 3.3S-W Electronic Trip Unit Instantaneous Trip Curve

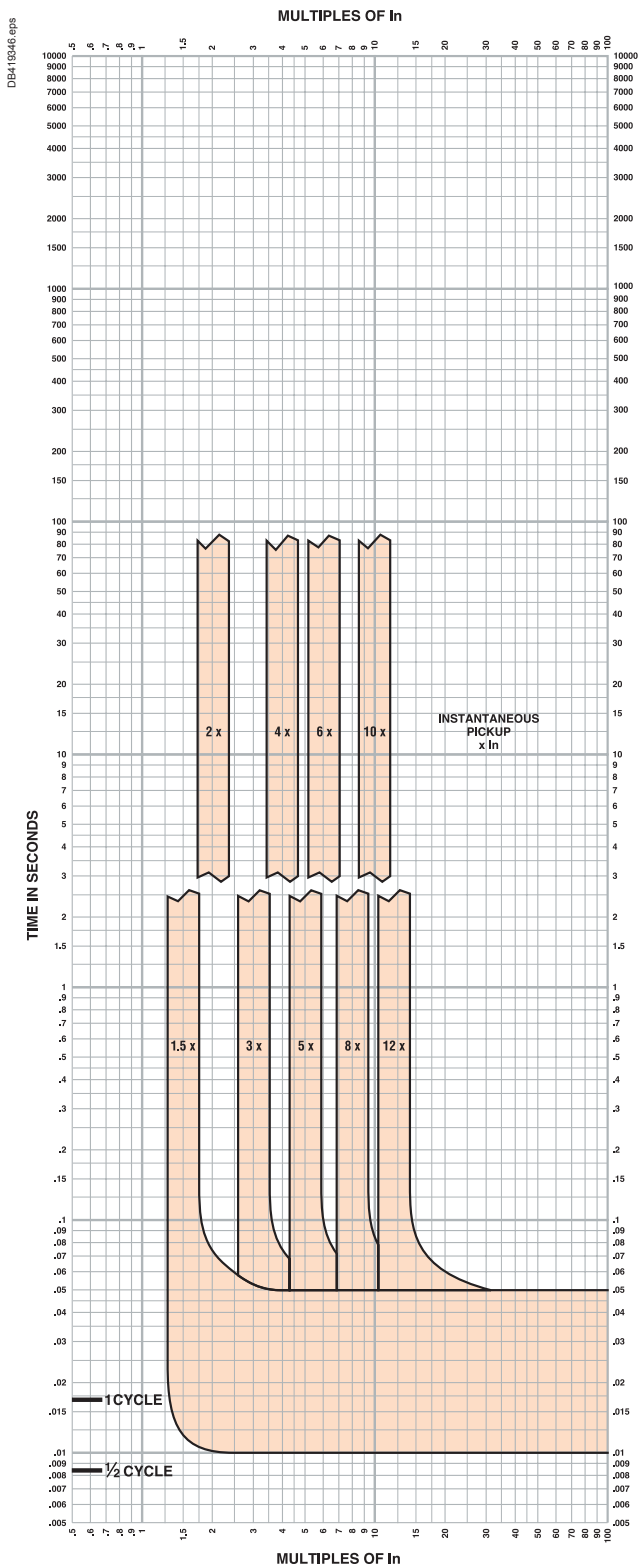

MICROLOGIC™ ELECTRONIC TRIP UNITS Micrologic™ 3.3, 3.3-W, 3.3S, and 3.3S-W Instantaneous Trip Curve 250 A L-Frame

The time-current curve information is to be used for application and coordination purposes only.

(1) There is a thermal-imaging effect that can act to shorten the long-time delay. The thermal imaging effect comes into play if a current above the long-time delay pickup value exists for a time and then is cleared by the tripping of a downstream device or the circuit breaker itself. A subsequent overload will cause the circuit breaker to trip in a shorter time than normal. The amount of time delay reduction is inverse to the amount of time that has elapsed since the previous overload. Approximately 20 minutes is required between overloads to completely reset thermal-imaging.

(2) Total clearing times shown include the response times of the trip unit, the circuit breaker opening, and the extinction of the current.

(3) I_n = Maximum dial setting of I_r .

250 A L-Frame: $I_n = 250 A = \text{Max } I_r \text{ setting}$

Curves apply from -35°C to $+70^\circ\text{C}$ (-31°F to $+158^\circ\text{F}$) ambient temperature.

PowerPact™ H-, J-, and L-Frame Circuit Breakers

Micrologic 3.3, 3.3-W, 3.3S, 3.3S-W, 5.3A, 5.3A-W, 5.3E, 5.3E-W, 6.3A, 6.3A-W, 6.3E, and 6.3E-W Electronic Trip Unit Instantaneous Trip Curve

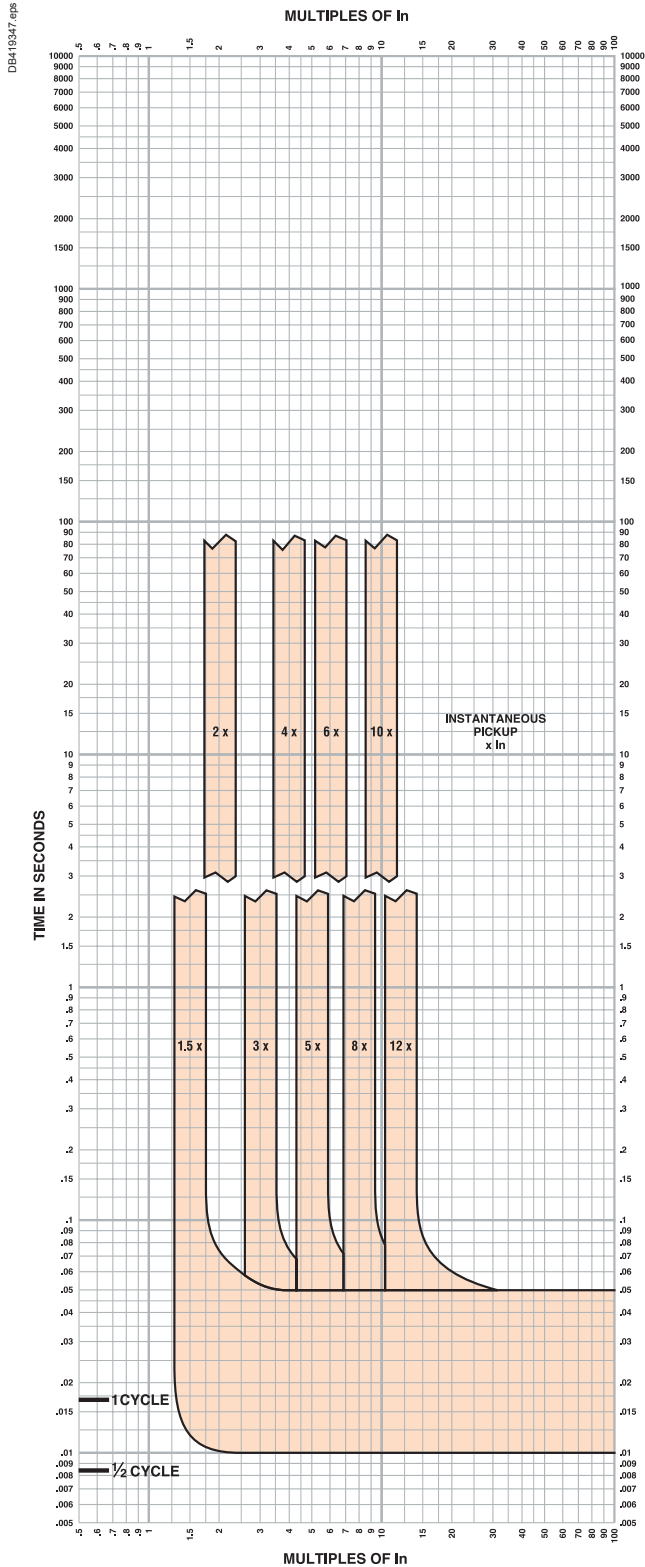

MICROLOGIC™ ELECTRONIC TRIP UNITS Micrologic™ 3.3, 3.3-W, 3.3S, 3.3S-W, 5.3A, 5.3A-W, 5.3E, 5.3E-W, 6.3A, 6.3A-W, 6.3E, and 6.3E-W Instantaneous Trip Curve 400 A L-Frame

The time-current curve information is to be used for application and coordination purposes only.

(1) There is a thermal-imaging effect that can act to shorten the long-time delay. The thermal imaging effect comes into play if a current above the long-time delay pickup value exists for a time and then is cleared by the tripping of a downstream device or the circuit breaker itself. A subsequent overload will cause the circuit breaker to trip in a shorter time than normal. The amount of time delay reduction is inverse to the amount of time that has elapsed since the previous overload. Approximately 20 minutes is required between overloads to completely reset thermal-imaging.

(2) Total clearing times shown include the response times of the trip unit, the circuit breaker opening, and the extinction of the current.

(3) I_n = Maximum dial setting of I_r .

400 A L-Frame: I_n = 400 A = Max I_r setting

Curves apply from -35 °C to +70 °C (-31 °F to +158 °F) ambient temperature.

Micrologic 5.3A, 5.3A-W, 5.3E, 5.3E-W, 6.3A, 6.3A-W, 6.3E, and 6.3E-W Electronic Trip Unit Long Time Trip Curve

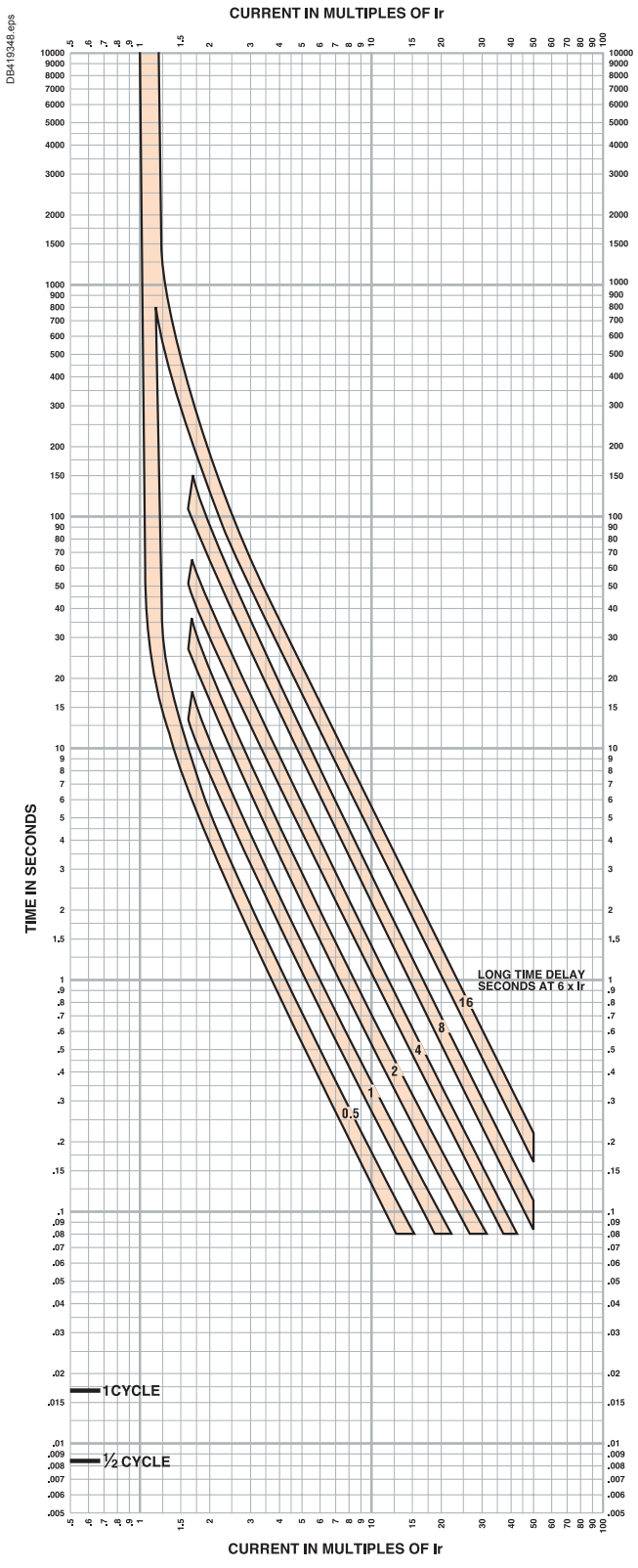

MICROLOGIC™ ELECTRONIC TRIP UNITS
Micrologic™ 5.3A, 5.3A-W, 5.3E, 5.3E-W, 6.3A,
6.3A-W, 6.3E, and 6.3E-W
Long Time Trip Curve
400 A L-Frame

The time-current curve information is to be used for application and coordination purposes only.

(1) There is a thermal-imaging effect that can act to shorten the long-time delay. The thermal imaging effect comes into play if a current above the long-time delay pickup value exists for a time and then is cleared by the tripping of a downstream device or the circuit breaker itself. A subsequent overload will cause the circuit breaker to trip in a shorter time than normal. The amount of time delay reduction is inverse to the amount of time that has elapsed since the previous overload. Approximately 20 minutes is required between overloads to completely reset thermal-imaging.

(2) Total clearing times shown include the response times of the trip unit, the circuit breaker opening, and the extinction of the current. Curves apply from -35 °C to +70 °C (-31 °F to +158 °F) ambient temperature.

PowerPact™ H-, J-, and L-Frame Circuit Breakers

Micrologic 5.3, 5.3A-W, 5.3E, 5.3E-W, 6.3A, 6.3A-W, 6.3E, and 6.3E-W Electronic Trip Unit Short Time Trip Curve

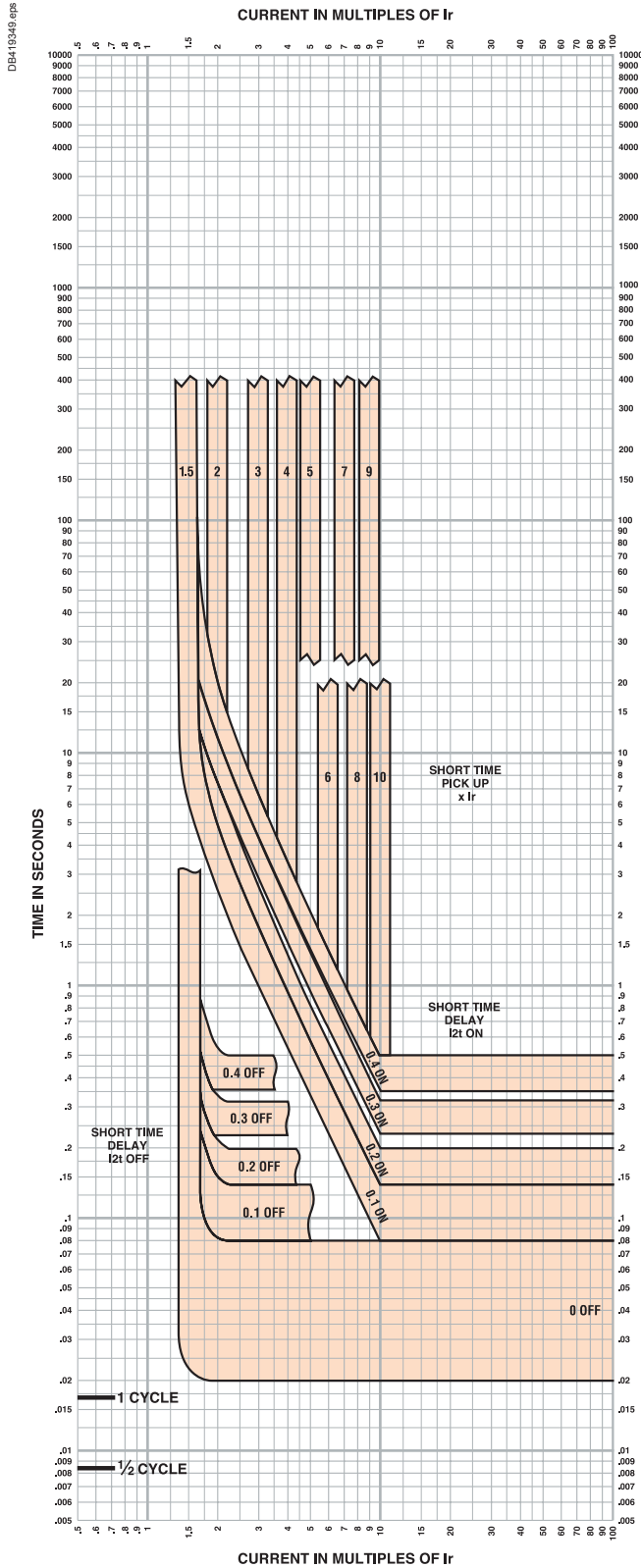

MICROLOGIC™ ELECTRONIC TRIP UNITS Micrologic™ 5.3A, 5.3A-W, 5.3E, 5.3E-W, 6.3A, 6.3A-W, 6.3E, and 6.3E-W Short Time Trip Curve 400 A L-Frame

The time-current curve information is to be used for application and coordination purposes only.

(1) There is a thermal-imaging effect that can act to shorten the long-time delay. The thermal imaging effect comes into play if a current above the long-time delay pickup value exists for a time and then is cleared by the tripping of a downstream device or the circuit breaker itself. A subsequent overload will cause the circuit breaker to trip in a shorter time than normal. The amount of time delay reduction is inverse to the amount of time that has elapsed since the previous overload. Approximately 20 minutes is required between overloads to completely reset thermal-imaging.

(2) Total clearing times shown include the response times of the trip unit, the circuit breaker opening, and the extinction of the current.

Curves apply from -35 °C to +70 °C (-31 °F to +158 °F) ambient temperature.

Micrologic 1.3 M Electronic Trip Unit Instantaneous Trip Curve

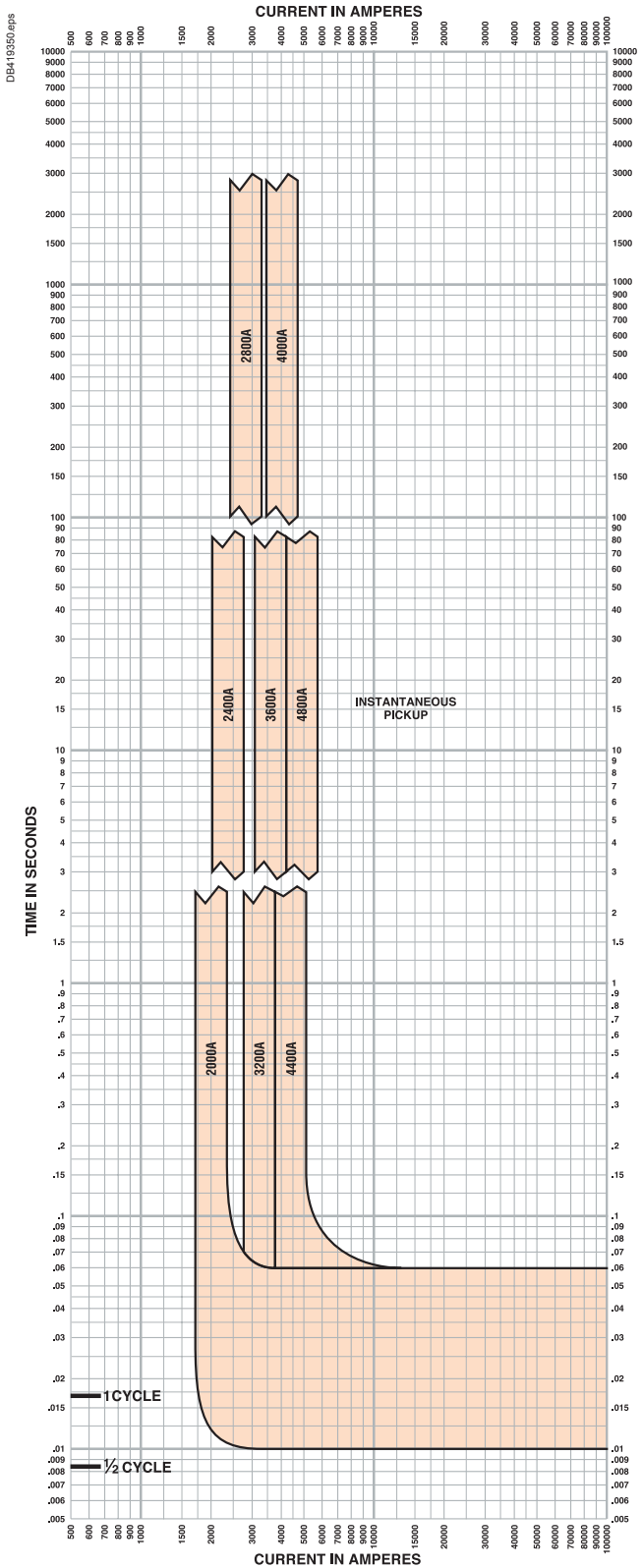

MICROLOGIC™ ELECTRONIC TRIP UNITS Micrologic™ 1.3M Instantaneous Trip Curve 400 A L-Frame

The time-current curve information is to be used for application and coordination purposes only.

(1) Total clearing times shown include the response times of the trip unit, the circuit breaker opening, and the extinction of the current.

Curves apply from -35 °C to +70 °C (-31 °F to +158 °F) ambient temperature.

Micrologic 2.3 M Electronic Trip Unit Overload Trip Curve

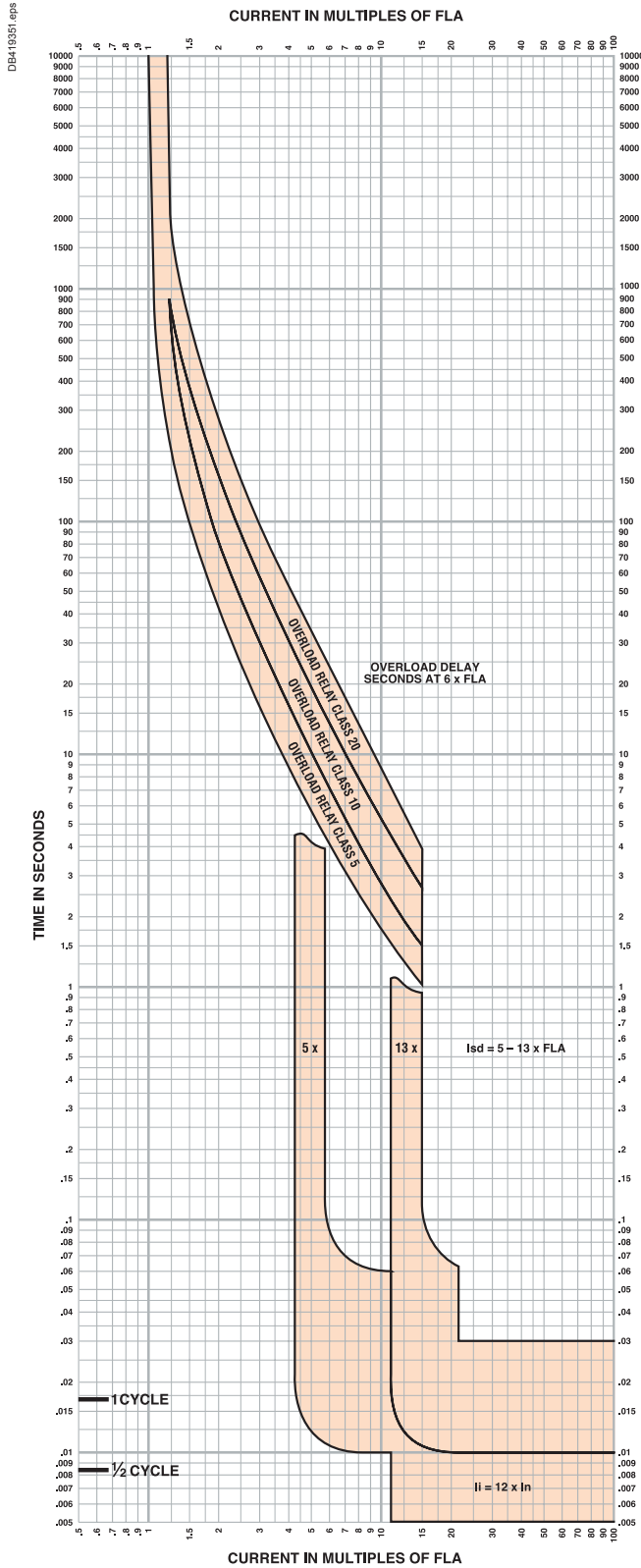

MICROLOGIC™ ELECTRONIC TRIP UNITS Micrologic™ 2.3M Overload Trip Curve 400 A, 600A L-Frame

The time-current curve information is to be used for application and coordination purposes only.

(1) If overload still exists past overload relay delay, MCP will open 0.4 seconds later.

(2) Total clearing times shown include the response times of the trip unit, the circuit breaker opening, and the extinction of the current.

(3) Isd minimum and maximum only shown.

(4) $I_i = 12 \times I_n$

$I_n = 400 \text{ A}, 600 \text{ A}$

MCP will trip < 30 ms at $12 \times I_n$

Curves apply from $-35 \text{ }^\circ\text{C}$ to $+70 \text{ }^\circ\text{C}$ ($-31 \text{ }^\circ\text{F}$ to $+158 \text{ }^\circ\text{F}$) ambient temperature.

Micrologic 3.3 and 3.3W Electronic Trip Unit Long Time Trip Curve

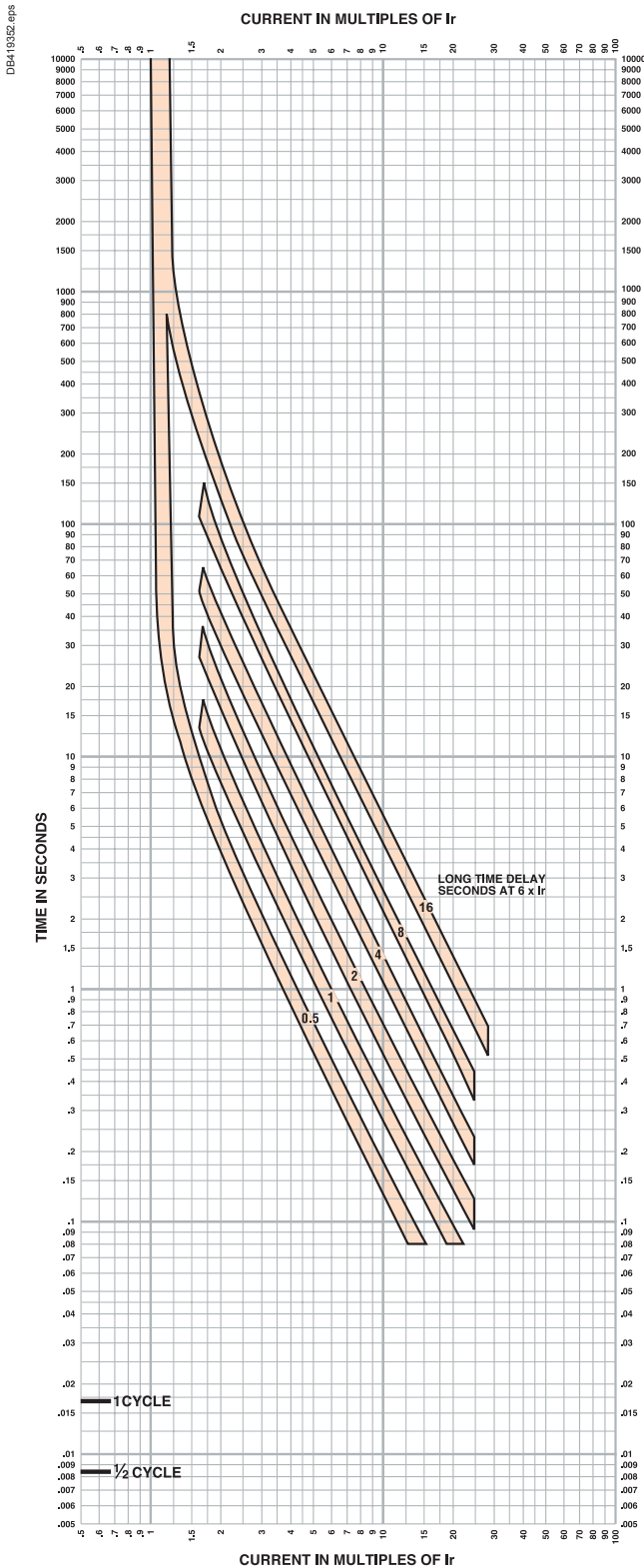

MICROLOGIC™ ELECTRONIC TRIP UNITS Micrologic™ 3.3 and 3.3-W Long Time Trip Curve 600 A L-Frame

The time-current curve information is to be used for application and coordination purposes only.

(1) There is a thermal-imaging effect that can act to shorten the long-time delay. The thermal imaging effect comes into play if a current above the long-time delay pickup value exists for a time and then is cleared by the tripping of a downstream device or the circuit breaker itself. A subsequent overload will cause the circuit breaker to trip in a shorter time than normal. The amount of time delay reduction is inverse to the amount of time that has elapsed since the previous overload. Approximately 20 minutes is required between overloads to completely reset thermal-imaging.

(2) Total clearing times shown include the response times of the trip unit, the circuit breaker opening, and the extinction of the current. Curves apply from -35 °C to +70 °C (-31 °F to +158 °F) ambient temperature.

Micrologic 3.3S and 3.3S-W Electronic Trip Unit Long Time / Short Time Trip Curve

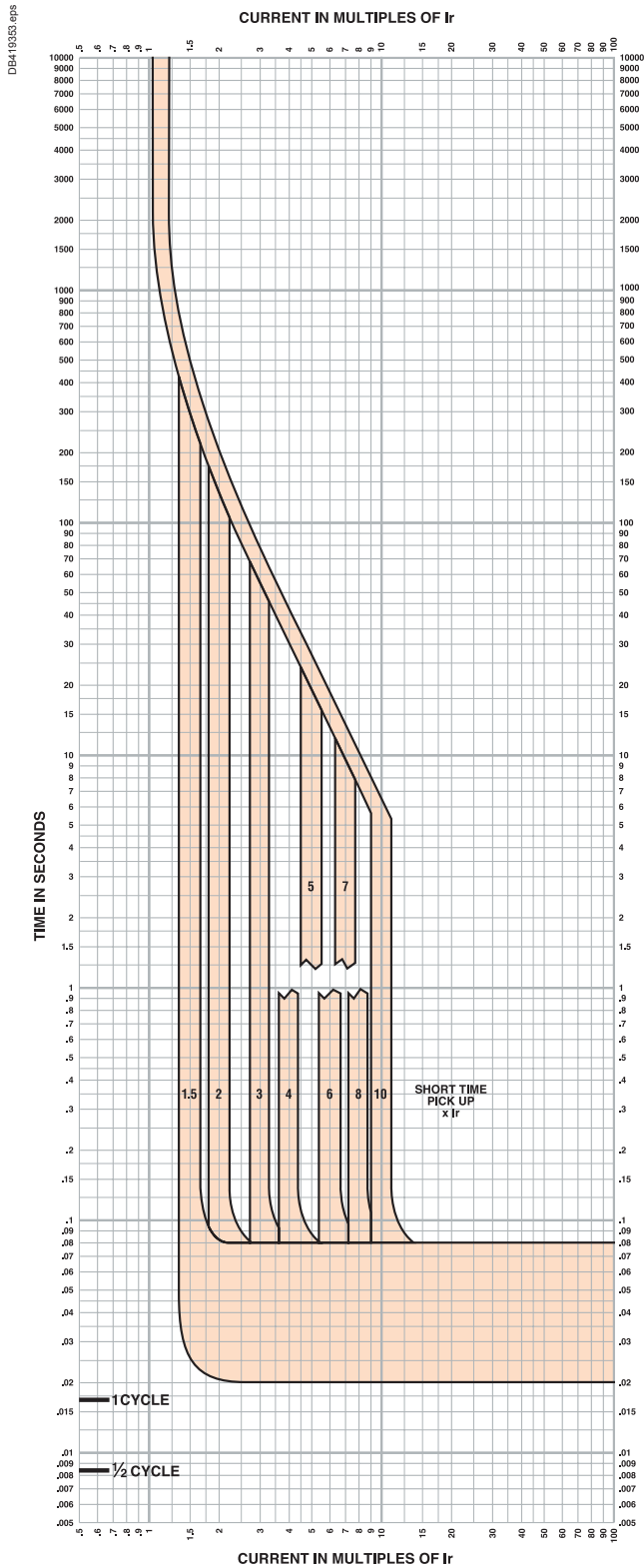

MICROLOGIC™ ELECTRONIC TRIP UNITS Micrologic™ 3.3S and 3.3S-W Long Time/Short Time Trip Curve 600 A L-Frame

The time-current curve information is to be used for application and coordination purposes only.

(1) There is a thermal-imaging effect that can act to shorten the long-time delay. The thermal imaging effect comes into play if a current above the long-time delay pickup value exists for a time and then is cleared by the tripping of a downstream device or the circuit breaker itself. A subsequent overload will cause the circuit breaker to trip in a shorter time than normal. The amount of time delay reduction is inverse to the amount of time that has elapsed since the previous overload. Approximately 20 minutes is required between overloads to completely reset thermal-imaging.

(2) Total clearing times shown include the response times of the trip unit, the circuit breaker opening, and the extinction of the current. Curves apply from -35 °C to +70 °C (-31 °F to +158 °F) ambient temperature.

Micrologic 3.3, 3.3-W, 3.3S, 3.3S-W, 5.3A, 5.3A-W, 5.3E, 5.3E-W, 6.3A, 6.3A-W, 6.3E, and 6.3E-W Electronic Trip Unit Instantaneous Trip Curve

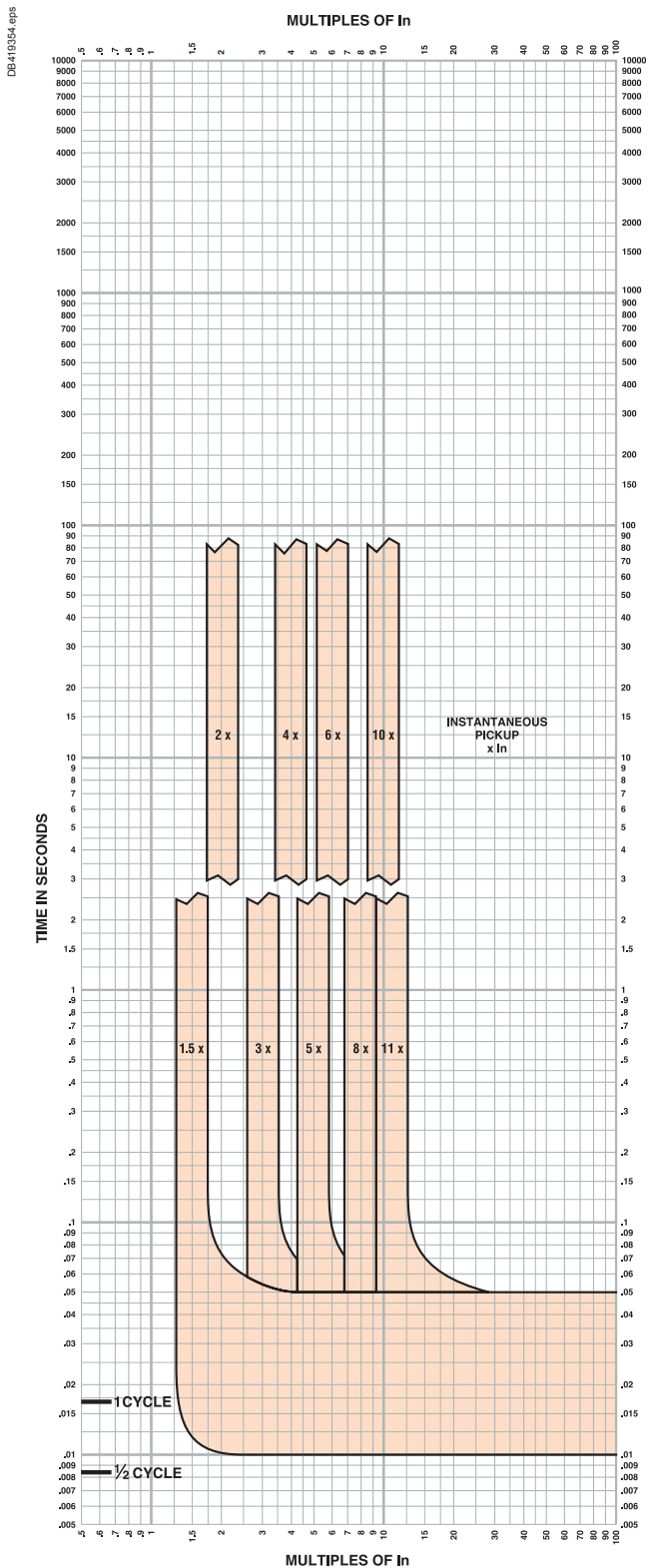

MICROLOGIC™ ELECTRONIC TRIP UNITS Micrologic™ 3.3, 3.3-W, 3.3S, 3.3S-W, 5.3A, 5.3A-W, 5.3E, 5.3E-W, 6.3A, 6.3A-W, 6.3E, and 6.3E-W Instantaneous Trip Curve 600 A L-Frame

The time-current curve information is to be used for application and coordination purposes only.

(1) There is a thermal-imaging effect that can act to shorten the long-time delay. The thermal imaging effect comes into play if a current above the long-time delay pickup value exists for a time and then is cleared by the tripping of a downstream device or the circuit breaker itself. A subsequent overload will cause the circuit breaker to trip in a shorter time than normal. The amount of time delay reduction is inverse to the amount of time that has elapsed since the previous overload. Approximately 20 minutes is required between overloads to completely reset thermal-imaging.

(2) Total clearing times shown include the response times of the trip unit, the circuit breaker opening, and the extinction of the current.

(3) I_n = Maximum dial setting of I_r .

600 A L-Frame: $I_n = 600 \text{ A} = \text{Max } I_r \text{ setting}$

Curves apply from $-35 \text{ }^\circ\text{C}$ to $+70 \text{ }^\circ\text{C}$ ($-31 \text{ }^\circ\text{F}$ to $+158 \text{ }^\circ\text{F}$) ambient temperature.

PowerPact™ H-, J-, and L-Frame Circuit Breakers

Micrologic 5.3A, 5.3A-W, 5.3E, 5.3E-W, 6.3A, 6.3A-W, 6.3E, and 6.3E-W Electronic Trip Unit Long Time Trip Curve

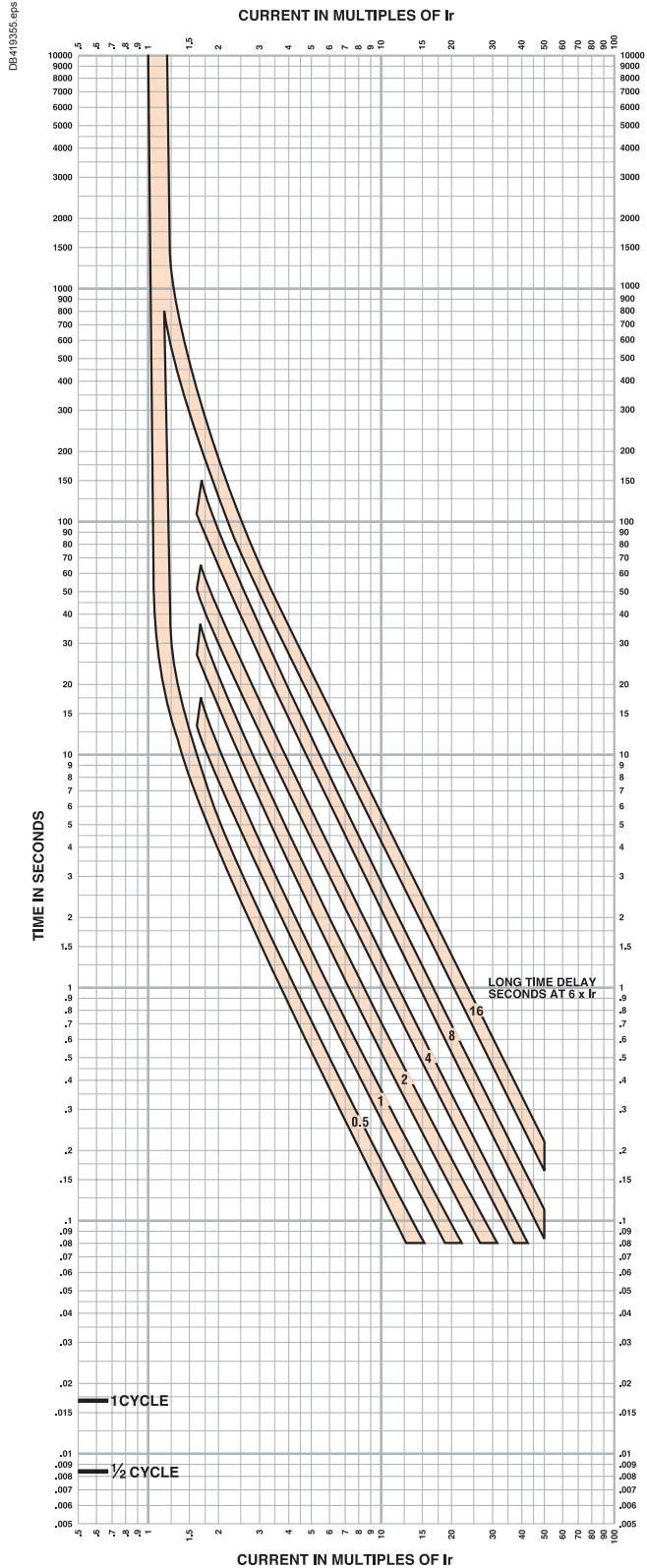

MICROLOGIC™ ELECTRONIC TRIP UNITS Micrologic™ 5.3A, 5.3A-W, 5.3E, 5.3E-W, 6.3A, 6.3A-W, 6.3E, and 6.3E-W Long Time Trip Curve 600 A L-Frame

The time-current curve information is to be used for application and coordination purposes only.

(1) There is a thermal-imaging effect that can act to shorten the long-time delay. The thermal imaging effect comes into play if a current above the long-time delay pickup value exists for a time and then is cleared by the tripping of a downstream device or the circuit breaker itself. A subsequent overload will cause the circuit breaker to trip in a shorter time than normal. The amount of time delay reduction is inverse to the amount of time that has elapsed since the previous overload. Approximately 20 minutes is required between overloads to completely reset thermal-imaging.

(2) Total clearing times shown include the response times of the trip unit, the circuit breaker opening, and the extinction of the current. Curves apply from $-35\text{ }^\circ\text{C}$ to $+70\text{ }^\circ\text{C}$ ($-31\text{ }^\circ\text{F}$ to $+158\text{ }^\circ\text{F}$) ambient temperature.

Micrologic 5.3A, 5.3A-W, 5.3E, 5.3E-W, 6.3A, 6.3A-W, 6.3E, and 6.3E-W Electronic Trip Unit Short Time Trip Curve

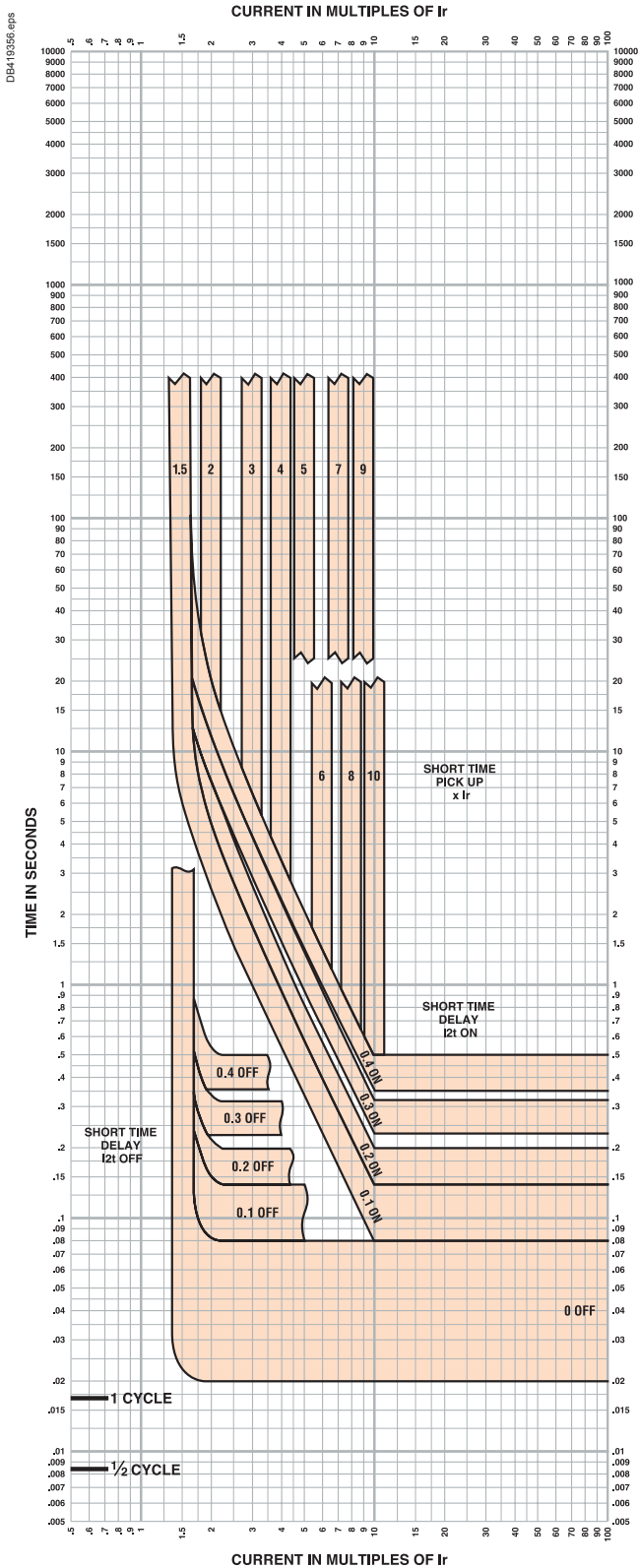

MICROLOGIC™ ELECTRONIC TRIP UNITS
Micrologic™ 5.3A, 5.3A-W, 5.3E, 5.3E-W, 6.3A,
6.3A-W, 6.3E, and 6.3E-W
Short Time Trip Curve
600 A L-Frame

The time-current curve information is to be used for application and coordination purposes only.

(1) There is a thermal-imaging effect that can act to shorten the long-time delay. The thermal imaging effect comes into play if a current above the long-time delay pickup value exists for a time and then is cleared by the tripping of a downstream device or the circuit breaker itself. A subsequent overload will cause the circuit breaker to trip in a shorter time than normal. The amount of time delay reduction is inverse to the amount of time that has elapsed since the previous overload. Approximately 20 minutes is required between overloads to completely reset thermal-imaging.

(2) Total clearing times shown include the response times of the trip unit, the circuit breaker opening, and the extinction of the current. Curves apply from -35 °C to +70 °C (-31 °F to +158 °F) ambient temperature.

Micrologic 6.3A, 6.3A-W, 6.3E, and 6.3E-W Ground-Fault Trip Curve

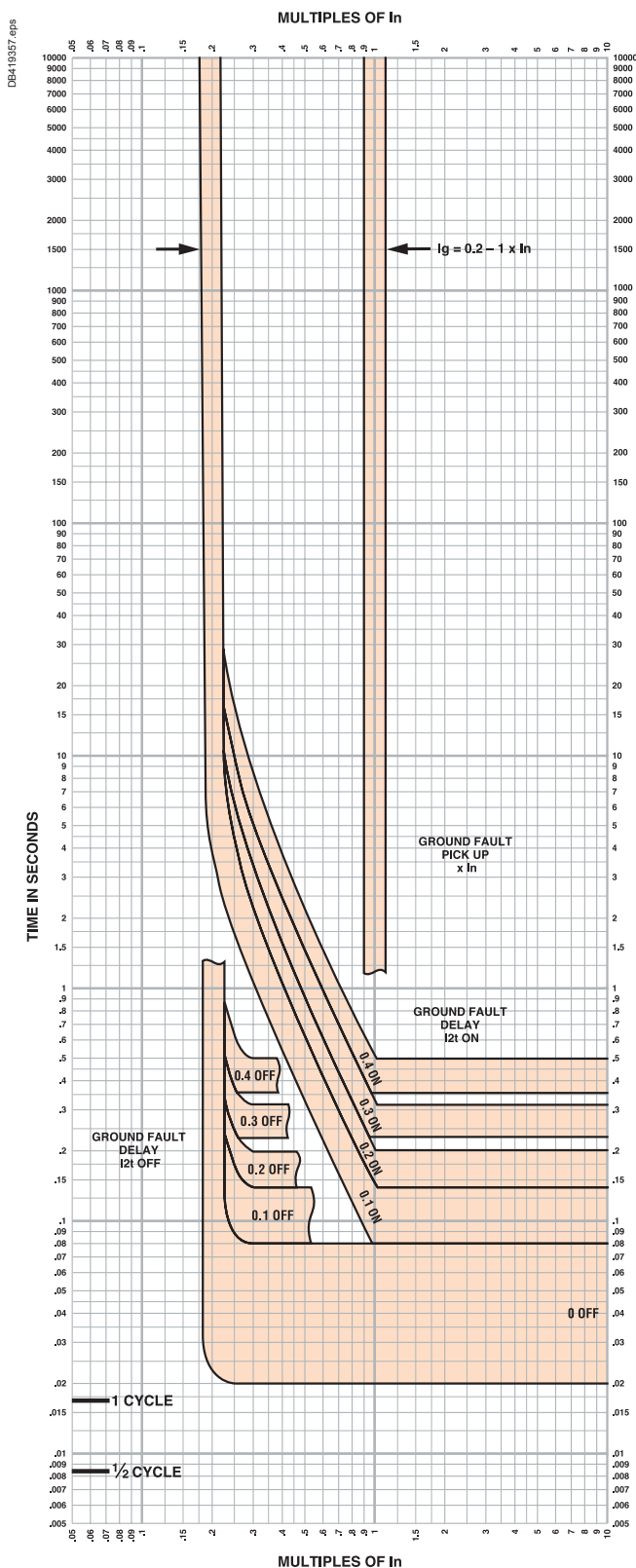

MICROLOGIC™ ELECTRONIC TRIP UNITS Micrologic™ 6.3A, 6.3A-W, 6.3E, and 6.3E-W Ground Fault Trip Curve 400 A, 600 A L-Frame

The time-current curve information is to be used for application and coordination purposes only.

(1) Total clearing times shown include the response times of the trip unit, the circuit breaker opening, and the extinction of the current.
Curves apply from -35 °C to +70 °C (-31 °F to +158 °F) ambient temperature.

Micrologic 1.3 M Electronic Trip Unit Instantaneous Trip Curve

MICROLOGIC™ ELECTRONIC TRIP UNITS Micrologic™ 1.3M Instantaneous Trip Curve 600 A L-Frame

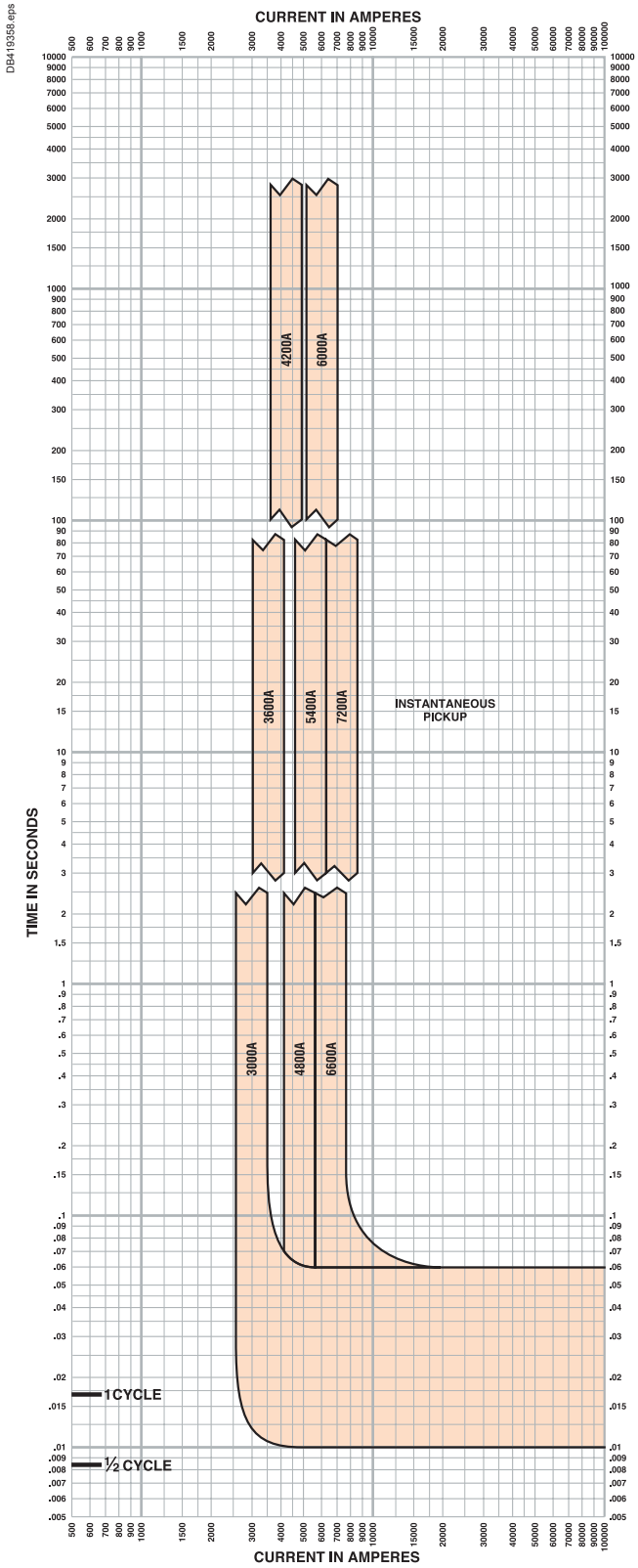

The time-current curve information is to be used for application and coordination purposes only.

(1) Total clearing times shown include the response times of the trip unit, the circuit breaker opening, and the extinction of the current.

Curves apply from -35 °C to +70 °C (-31 °F to +158 °F) ambient temperature.

L-Frame 600 A Typical Peak Let-Through Curves

ELECTRONIC MOLDED CASE CIRCUIT BREAKERS
 POWERPACT™ L-FRAME CURRENT LIMITING CIRCUIT BREAKERS
 600 A FRAME AT 240, 480 AND 600 V, 3Ø
 LD, LG, LJ, LL AND LR 250-600 A
 PEAK LET-THROUGH CURRENT I_p

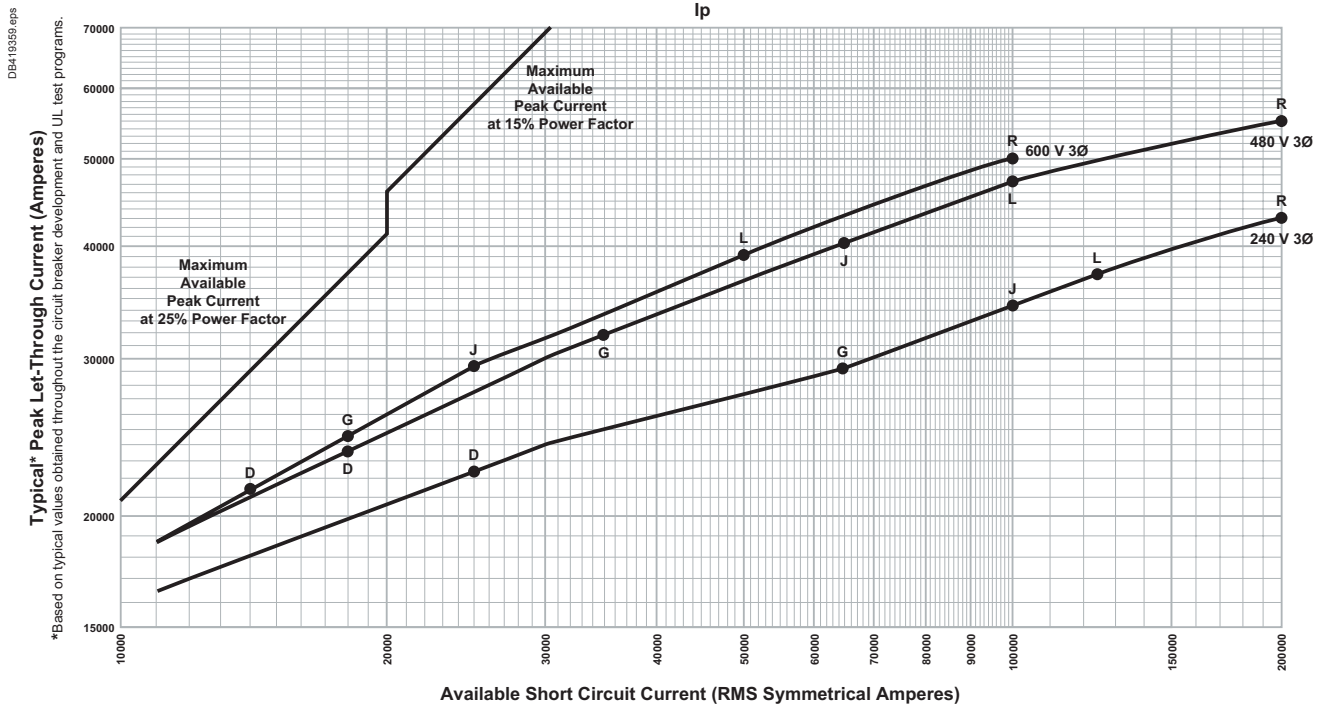

L-Frame 600 A Typical I²t Let-Through Curves

ELECTRONIC MOLDED CASE CIRCUIT BREAKERS
 POWERPACT™ L-FRAME CURRENT LIMITING CIRCUIT BREAKERS
 600 A FRAME AT 240, 480 AND 600 V, 3Ø
 LD, LG, LJ, LL AND LR 250-600 A

LET-THROUGH I²t

I²t

DB419360.eps
 Typical* Let-Through I²t (Amperes² Seconds x 10⁶)
 *Based on typical values obtained throughout the circuit breaker development and UL test programs.

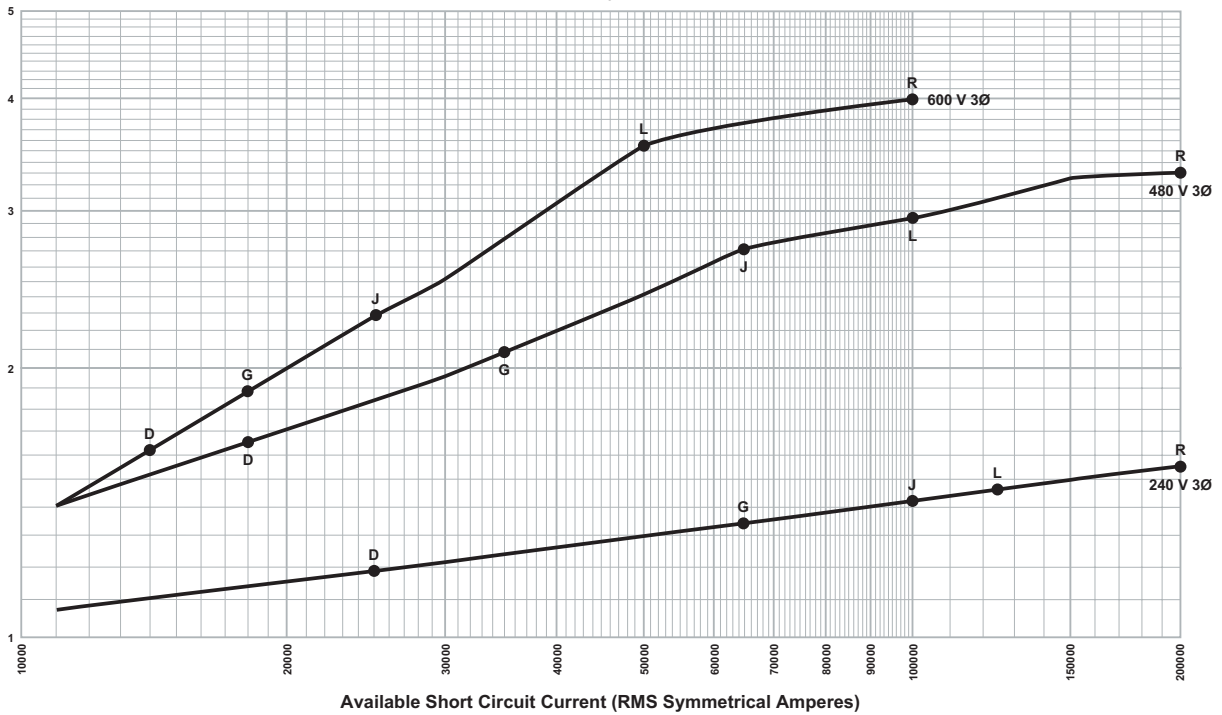

L-Frame UL Listed Current-Limiting Circuit Breaker

**ELECTRONIC MOLDED CASE CIRCUIT BREAKERS
POWERPACT™ L-FRAME CURRENT LIMITING CIRCUIT BREAKERS
600 A FRAME AT 240, 480 AND 600 V, 3Ø
LJ, LL AND LR 250-600 A
PEAK LET-THROUGH CURRENT I_p**

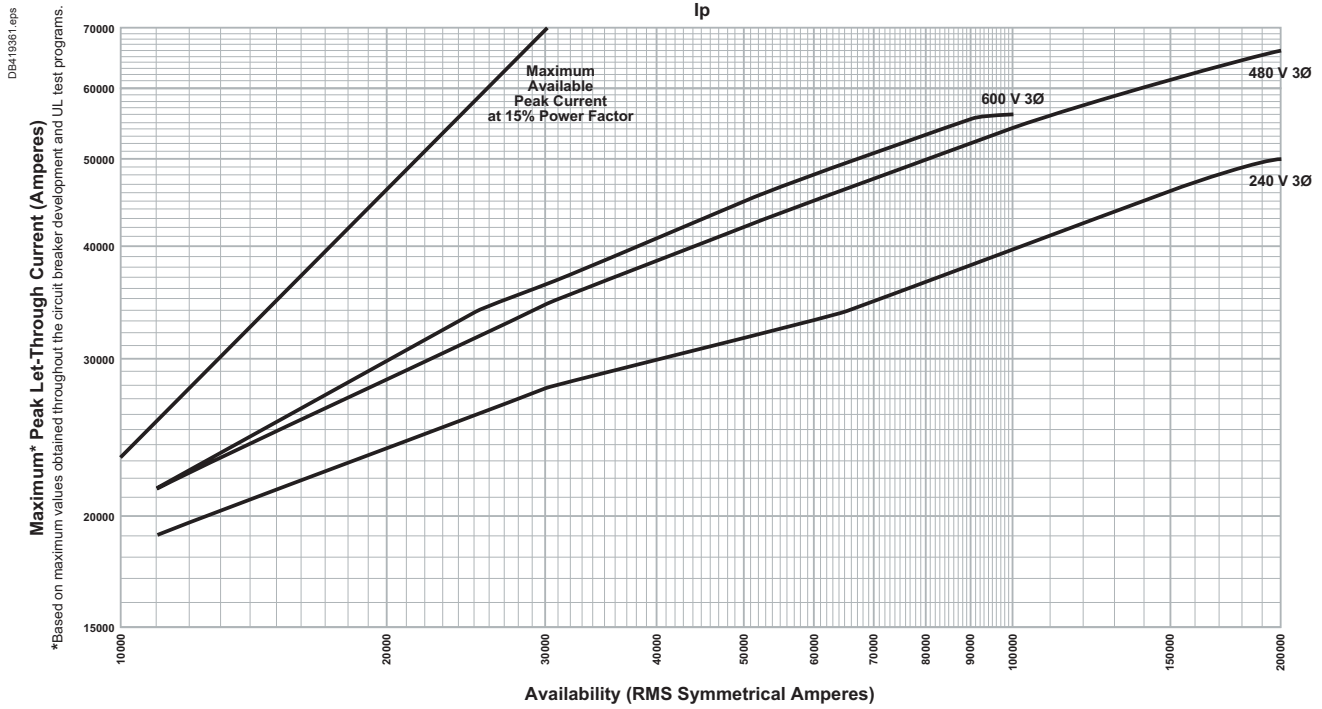

L-Frame UL Listed Current-Limiting Circuit Breaker

ELECTRONIC MOLDED CASE CIRCUIT BREAKERS
 POWERPACT™ L-FRAME CURRENT LIMITING CIRCUIT BREAKERS
 600 A FRAME AT 240, 480 AND 600 V, 3Ø
 LJ, LL AND LR 250-600 A

DB41932.eps

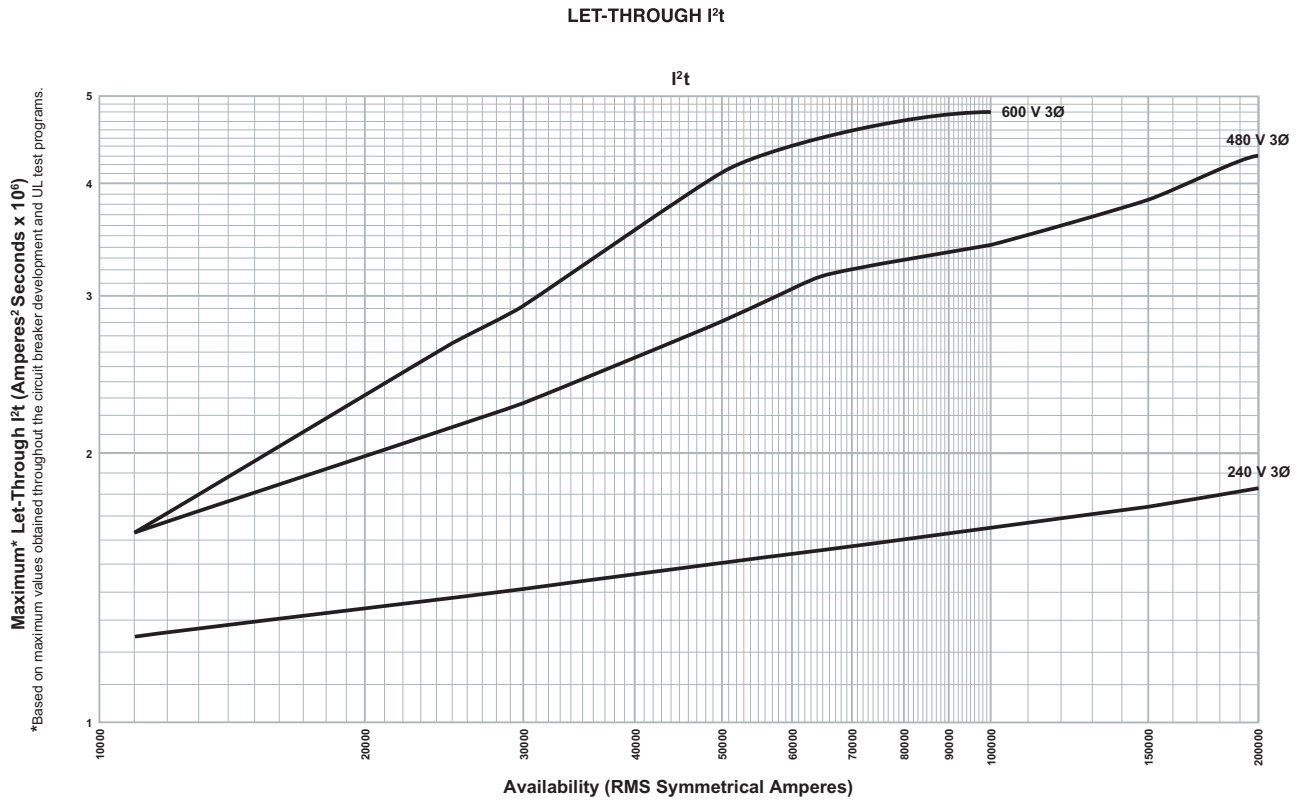

L-Frame Circuit Breaker Reflex Tripping

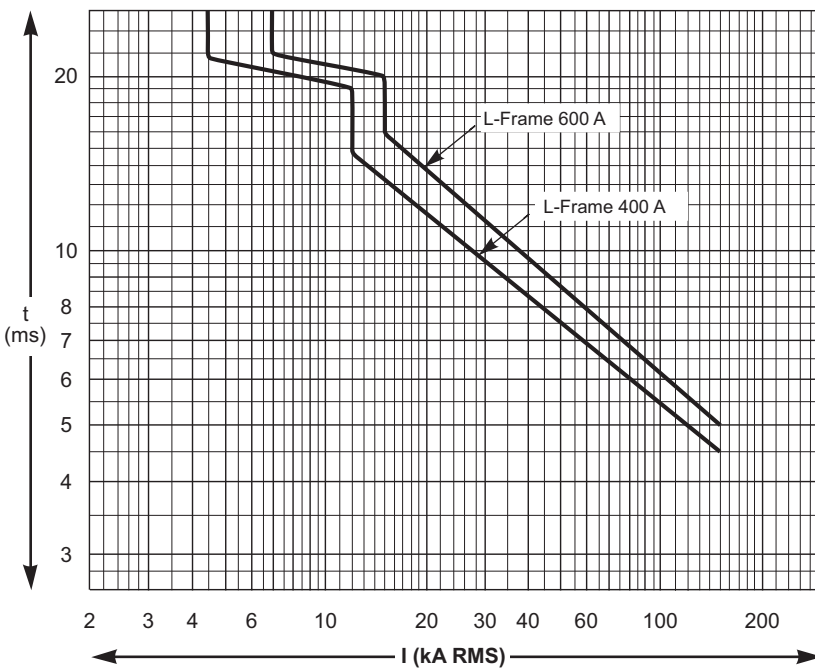

Distribution system

Plates for mounting on busbars

Short-circuit withstand capability

Determining the spacing between busbar supports (LA9ZX01495 and LA9ZX01485), according to IEC 60439-1 ⁽¹⁾

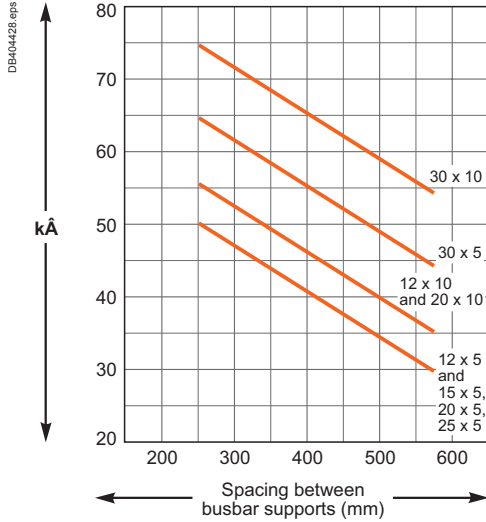

Short-circuit strength diagram according to UL845 (LA9ZX01503)

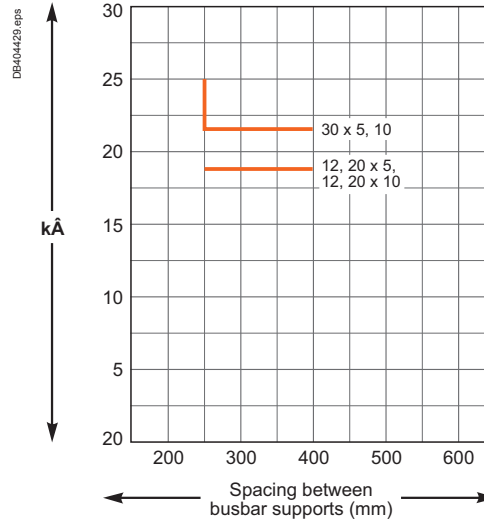

(1) Depending on the short-circuit current.

Load resistance of busbar assemblies in IEC applications

For an ambient temperature of 35 °C and a busbar temperature of 65 °C

Cross section	mm ²	12 x 5	15 x 5	20 x 5	25 x 5	30 x 5	12 x 10	20 x 10	30 x 10
Permissible current	A	200	250	320	400	450	360	520	630

In the event of changes in climatic conditions, the following curve indicates the correction factor K_2 to be applied.

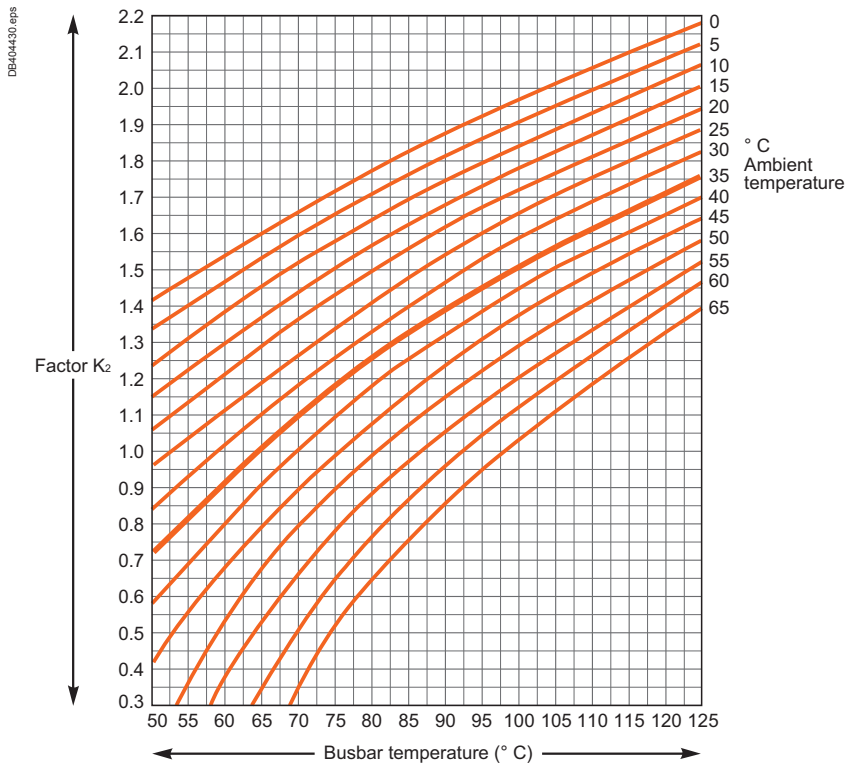

Example: In normal operating conditions, a tinned busbar of 30 x 10 can permanently withstand 630 A.

For a load of 800 A, the correction factor K_2 to be applied will be $1.3 \left(\frac{800 \text{ A}}{630 \text{ A}} \right)$. As a result, the temperature rise in the busbars will reach 82.5 °C.

<i>Functions and characteristics</i>	A-1
<i>Installation recommendations</i>	B-1
<i>Dimensions</i>	C-1
<i>Wiring diagrams</i>	D-1
<i>Additional characteristics</i>	E-1
H-Frame, J-Frame unit-mount circuit breaker	F-2
H-Frame, J-Frame circuit breaker accessories	
Unit-mount circuit breaker	F-4
H-Frame, J-Frame, L-Frame unit-mount circuit breakers	F-9
PowerPact automatic molded case switches	F-10
L-Frame circuit breaker accessories	F-12
Monitoring and control, test tools	
PowerPact H- J- and L- Frame	F-16
Distribution system	
Busbar support and mounting plates	F-18
Terminals and connection module	F-19
<i>Glossary</i>	G-1

H-Frame, J-Frame unit-mount circuit breaker

PowerPact H-Frame 150 A unit-mount thermal-magnetic circuit breakers (480 V AC, 250 V DC)

With factory sealed trip unit (suitable for reverse connection)

DB413112.eps

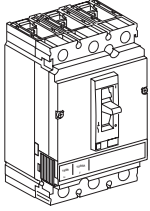

H-Frame, 150 A, 3P, 480 V AC 50/60 Hz, 250 V DC - bus bar connectors (with metric terminal nut)

Current rating at 40 °C (A)	Fixed AC magnetic trip (A)		Interrupting rating Standard (80 %) rated		
	Hold	Trip	D - 18 kA	G - 35 kA	J ⁽¹⁾ - 65 kA
15	350	750	NHDF36015TW	NHGF36015TW	NHJF36015TW
20	350	750	NHDF36020TW	NHGF36020TW	NHJF36020TW
30	350	750	NHDF36030TW	NHGF36030TW	NHJF36030TW
40	400	850	NHDF36040TW	NHGF36040TW	NHJF36040TW
50	400	850	NHDF36050TW	NHGF36050TW	NHJF36050TW
60	800	1450	NHDF36060TW	NHGF36060TW	NHJF36060TW
70	800	1450	NHDF36070TW	NHGF36070TW	NHJF36070TW
80	800	1450	NHDF36080TW	NHGF36080TW	NHJF36080TW
90	800	1450	NHDF36090TW	NHGF36090TW	NHJF36090TW
100	900	1700	NHDF36100TW	NHGF36100TW	NHJF36100TW
125	900	1700	NHDF36125TW	NHGF36125TW	NHJF36125TW
150	900	1700	NHDF36150TW	NHGF36150TW	NHJF36150TW

H-Frame, 150 A, 3P, 480 V AC 50/60 Hz, 250 V DC - lug lug connectors

Current rating at 40 °C (A)	Fixed AC magnetic trip (A)		Interrupting rating Standard (80 %) rated		
	Hold	Trip	D - 18 kA	G - 35 kA	J ⁽¹⁾ - 65 kA
15	350	750	NHDL36015	NHGL36015	NHJL36015
20	350	750	NHDL36020	NHGL36020	NHJL36020
30	350	750	NHDL36030	NHGL36030	NHJL36030
40	400	850	NHDL36040	NHGL36040	NHJL36040
50	400	850	NHDL36050	NHGL36050	NHJL36050
60	800	1450	NHDL36060	NHGL36060	NHJL36060
70	800	1450	NHDL36070	NHGL36070	NHJL36070
80	800	1450	NHDL36080	NHGL36080	NHJL36080
90	800	1450	NHDL36090	NHGL36090	NHJL36090
100	900	1700	NHDL36100	NHGL36100	NHJL36100
125	900	1700	NHDL36125	NHGL36125	NHJL36125
150	900	1700	NHDL36150	NHGL36150	NHJL36150

PowerPact J-Frame 250 A unit-mount thermal-magnetic circuit breakers

With factory sealed trip unit (suitable for reverse connection)

DB413113.eps

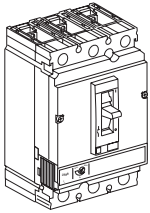

J-Frame, 250 A, 3P, 480 V AC 50/60 Hz, 250 V DC - bus bar connectors (with metric terminal nut)

Current rating at 40 °C (A)	Fixed AC magnetic trip (A)		Interrupting rating Standard (80 %) rated		
	Hold	Trip	D - 18 kA	G - 35 kA	J ⁽¹⁾ - 65 kA
150	750	1500	NJDF36150TW	NJGF36150TW	NJJF36150TW
175	875	1750	NJDF36175TW	NJGF36175TW	NJJF36175TW
200	1000	2000	NJDF36200TW	NJGF36200TW	NJJF36200TW
225	1125	2250	NJDF36225TW	NJGF36225TW	NJJF36225TW
250	1250	2500	NJDF36250TW	NJGF36250TW	NJJF36250TW

J-Frame, 250 A, 3P, 480 V AC 50/60 Hz, 250 V DC - lug lug connectors

Current rating at 40 °C (A)	Fixed AC magnetic trip (A)		Interrupting rating Standard (80 %) rated		
	Hold	Trip	D - 18 kA	G - 35 kA	J ⁽¹⁾ - 65 kA
150	750	1500	NJDL36150	NJGL36150	NJJL36150
175	875	1750	NJDL36175	NJGL36175	NJJL36175
200	1000	2000	NJDL36200	NJGL36200	NJJL36200
225	1125	2250	NJDL36225	NJGL36225	NJJL36225
250	1250	2500	NJDL36250	NJGL36250	NJJL36250

(1) UL Listed/CSA Certified as current limiting circuit breakers.

H-Frame, J-Frame unit-mount circuit breaker

DB413114.eps

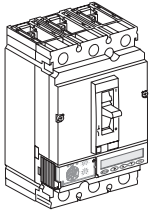

H-Frame 150 A and J-Frame 250 A electronic trip UL rated circuit breakers (480 V AC, 50/60 Hz)

With factory sealed trip unit (suitable for reverse connection)

PowerPact bus bar connectors (with metric terminal nut)

Electronic trip unit type	Trip function	Sensor rating (A)	Interrupting rating Standard (80 %) rated		
			D - 18 kA	G - 35 kA	J ⁽¹⁾ - 65 kA

Micrologic 3.2

Standard	LI	60	NHDF36060U31XTW	NHGF36060U31XTW	NHJF36060U31XTW
		100	NHDF36100U31XTW	NHGF36100U31XTW	NHJF36100U31XTW
		150	NHDF36150U31XTW	NHGF36150U31XTW	NHJF36150U31XTW
		250	NJDF36250U31XTW	NJGF36250U31XTW	NJJF36250U31XTW

Micrologic 5.2 E

Energy	LSI	60	NHDF36060U53XTW	NHGF36060U53XTW	NHJF36060U53XTW
		100	NHDF36100U53XTW	NHGF36100U53XTW	NHJF36100U53XTW
		150	NHDF36150U53XTW	NHGF36150U53XTW	NHJF36150U53XTW
		250	NJDF36250U53XTW	NJGF36250U53XTW	NJJF36250U53XTW

PowerPact lug lug connectors

Electronic trip unit type	Trip function	Sensor rating (A)	Interrupting rating Standard (80 %) rated		
			D - 18 kA	G - 35 kA	J ⁽¹⁾ - 65 kA

Micrologic 3.2

Standard	LI	60	NHDL36060U31X	NHGL36060U31X	NHJL36060U31X
		100	NHDL36100U31X	NHGL36100U31X	NHJL36100U31X
		150	NHDL36150U31X	NHGL36150U31X	NHJL36150U31X
		250	NJDL36250U31X	NJGL36250U31X	NJJL36250U31X

Micrologic 5.2 E

Energy	LSI	60	NHDL36060U53X	NHGL36060U53X	NHJL36060U53X
		100	NHDL36100U53X	NHGL36100U53X	NHJL36100U53X
		150	NHDL36150U53X	NHGL36150U53X	NHJL36150U53X
		250	NJDL36250U53X	NJGL36250U53X	NJJL36250U53X

⁽¹⁾ UL Listed/CSA Certified as current limiting circuit breakers.

H-Frame, J-Frame circuit breaker accessories

Unit-mount circuit breaker

Rear connection

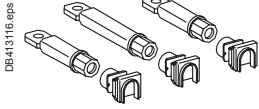

Description device	3P	
	H-Frame	J-Frame
Mixed rear connection Kit	S37432	S37437
Consisting of Short rear connections	Set of 2	2 x ⁽¹⁾ S37433
Long rear connections	Set of 2	2 x ⁽¹⁾ S37439
Short terminal cover	S37436	S37440

Plug-in version

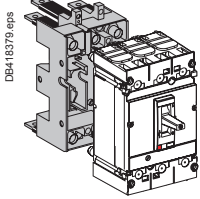

Kit for PowerPact H- and J-Frame		3P
Description device	H- and J-Frame	
Plug-in kit	S29278	

Withdrawable version

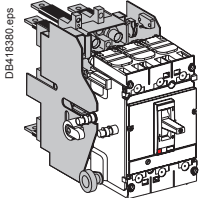

Kit for PowerPact H- and J-Frame		3P
Description device	H- and J-Frame	
Plug-in kit	S29278	
Cradle side plates (fixed part of chassis)	LV429282	
Circuit breaker side plates (moving part of chassis)	LV429283	

Plug-in and drawout accessories

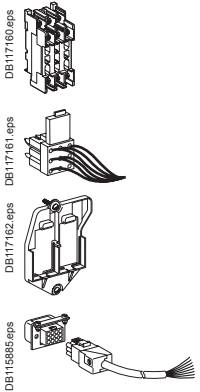

PowerPact H- and J-Frame		3P
Description device	H- and J-Frame	
H-Frame shutter kit	S37442	
J-Frame shutter kit	S37443	
9-wire fixed connector (for base)	LV429273	
9-wire moving connector (for CB)	LV429274	
Support for 2 moving connectors	LV429275	
Extended escutcheon for toggle	S29284	
2 position indicating switches (connected/disconnected)	LV429287	

Mechanical lug kits for H-Frame and J-Frame circuit breaker

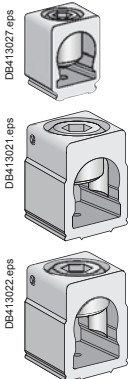

Circuit breaker application		Qty per kit	
Al lugs for use with Al or Cu wire (HD/HG/HJ)	15-150 A	3	AL150HDS
Al lugs for use with Al or Cu wire (JD/JG/JJ)	150-175 A	3	AL175JD
Al lugs for use with Al or Cu wire (JD/JG/JJ)	200-250 A	3	AL250JD

H-Frame, J-Frame circuit breaker accessories

Unit-mount circuit breaker

Terminal nuts for busbar connection

DB413175.eps

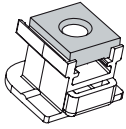

Description	Qty per kit				
H-Frame terminal nut insert-english (HD/HG/HJ)	1/4-20	9-10.2 Nm	2		S37425
H-Frame terminal nut insert-english (HD/HG/HJ)	1/4-20	9-10.2 Nm	3		S37444
H-Frame terminal nut insert-metric (HD/HG/HJ)	M6	9-10.2 Nm	2		S37426
J-Frame terminal nut insert-english (JD/JG/JJ)	1/4-20	9-10.2 Nm	2		S37427
J-Frame terminal nut insert-english (JD/JG/JJ)	1/4-20	9-10.2 Nm	3		S37445
J-Frame terminal nut insert-metric (JD/JG/JJ)	M8	9-10.2 Nm	2		S37428

Control wire terminals for mechanical lugs and terminal nuts

DB413026.eps

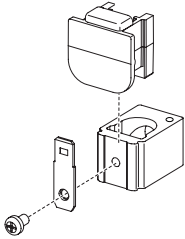

Mechanical lugs	Qty per kit		
Control wire terminal for H-frame lugs (HD/HG/HJ)	2		S37423
Control wire terminal for J-frame lugs (JD/JG/JJ)	2		S37424

Busbar connection

DB413060.eps

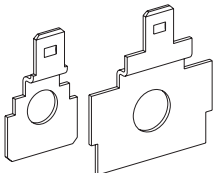

Control wire terminal for H-frame lugs terminal nut (HD/HG/HJ)	2	S37429
Control wire terminal for J-frame lugs terminal nut (JD/JG/JJ)	2	S37430

(1) Order two kits (two in kit x two kits for total of four).

H-Frame, J-Frame circuit breaker accessories

Unit-mount circuit breaker

Terminal shields

Used with

DB416076.eps

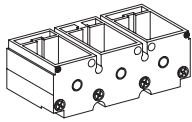

H- and J-Frame used with mechanical lugs		Qty per kit	
Short lug shield	H-Frame - 60 A 3 AWG	1	S37446
	H-Frame - 150 A 3/0 AWG	1	S37447
	J-Frame - 350 kcmil	1	S37448

DB413119.eps

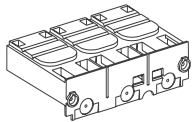

H- and J-Frame used with power distribution connectors and compression lugs			
Long lug shield	H-Frame	1	S37449
	J-Frame	1	S37450

Rotary operated handles

DB413121.eps

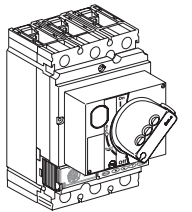

		H- and J-Frame
Direct mounted		
Standard black handle (handle only)		LV429337
Standard black handle with	One early-break switch	LV429337 + LV429345
	Two early-make switches	LV429337 + LV429346
Red handle on yellow bezel (handle only)		LV429339
MCC conversion accessory		LV429341
CNOMO conversion accessory		LV429342
Red handle on yellow bezel with	One early-break switch	LV429339 + LV429345
	Two early-make switches	LV429339 + LV429346
Door mounted		
Standard black handle (handle only)		LV429338
Standard black handle with	Two early-make switches	LV429338 + LV429346
Red handle on yellow bezel (handle only)		LV429340
Telescoping		
Telescoping		LV429343

Locking systems

DB413122.eps

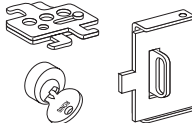

		H- and J-Frame
Handle padlocking device ⁽¹⁾	Removable (lock OFF only)	29370
	Fixed (lock OFF or ON)	29371
	Fixed (lock OFF only)	S37422

DB112263.eps

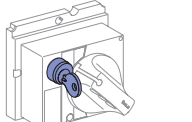

Locking of rotary handle	Keylock adapter (keylock not included)	LV429344
	Keylock (keylock adapter not included) Ronis 1351B.500	41940
	Keylock (keylock adapter not included) Profalux KS5 B24 D4Z	42888

DB112264.eps

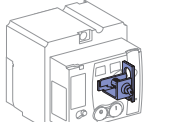

Locking of motor mechanism	Keylock adapter (keylock not included)	LV432649
----------------------------	--	----------

Installation accessories

Front-panel escutcheon IP40

DB416072.eps

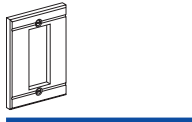

For toggle		H- and J-Frame
		29315

Lead - Sealing accessories

DB115615.eps



Bay of accessories		LV429375
--------------------	--	----------

(1) Rotary handle has integral padlocking capability.

H-Frame, J-Frame circuit breaker accessories

Unit-mount circuit breaker

Electrical auxiliaries

Auxiliary contacts (changeover)

DB112254.eps



OF or SD or SDE or SDV	29450
OF or SD or SDE or SDV low level	29452

SDx output module for Micrologic electronic trip unit

DB112275.eps

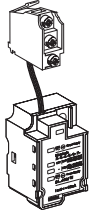

SDx module 24/415 V AC/DC	LV429532
---------------------------	----------

Voltage releases

DB111454.eps



	Voltage	MX	MN
AC	24 V 50/60 Hz	LV429384	LV429404
	48 V 50/60 Hz	LV429385	LV429405
	110-130 V 50/60 Hz	LV429386	LV429406
	220-240 V 50/60 Hz and 208-277 V 60 Hz	LV429387	LV429407
	380-415 V 50 Hz and 440-480 V 60 Hz	LV429388	LV429408
	525 V 50 Hz and 600 V 60 Hz	LV429389	LV429409
DC	12 V	LV429382	LV429402
	24 V	LV429390	LV429410
	30 V	LV429391	LV429411
	48 V	LV429392	LV429412
	60 V	LV429383	LV429403
	125 V	LV429393	LV429413
	250 V	LV429394	LV429414
MN 48 V DC 50/60 Hz			
	MN 48 V DC		LV429412
MN 110-130 V DC 50/60 Hz			
	MN 125 V DC		LV429413
MN 220-250 V 50/60 Hz			
	MN 250 V DC		LV429414

H-Frame, J-Frame circuit breaker accessories

Unit-mount circuit breaker

Motor mechanism

Motor mechanism module supplied with SDE adapter

DB129554.eps

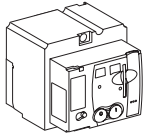

	Voltage	MT100/160	MT250
AC	48-60 V 50/60 Hz	LV429440	LV431548
	110-130 V 50/60 Hz	LV429433	LV431540
	220-240 V 50/60 Hz and 208-277 V 60 Hz	LV429434	LV431541
	380-415 V 50/60 Hz and 440-480 V 60 Hz	LV429435	LV431542
	DC	24-30 V	LV429436
	48-60 V	LV429437	LV431544
	110-130 V	LV429438	LV431545
	250 V	LV429439	LV431546

Communicating motor mechanism module supplied with SDE adapter

DB112285.eps

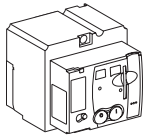

Motor mechanism module	220-240 V 50/60 Hz	MTC 100/160	LV429441
		MTC 250	LV431549

+

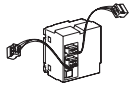

Breaker and Status Communication Module	BSCM	LV434205
--	------	----------

+



NSX cord	Wire length L = 1.3 m	LV434201
	Wire length L = 3 m	LV434202
	U > 480 V AC wire length L = 0.35 m	LV434204

H-Frame, J-Frame, L-Frame unit-mount circuit breakers

PowerPact H-Frame 150 A Electronic motor protector circuit breakers (UL ratings) - Two device solutions ⁽¹⁾

With factory sealed trip unit (suitable for reverse connection)

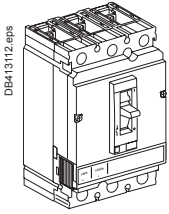

H-Frame, 150 A, 3P, 480 V AC 50/60 Hz - bus bar connectors (with metric terminal nut)		
Sensor rating (A)	Full Load Amperes Range (FLA)	Interrupting rating Standard (80 %) rated J - 65 kA
150	58 - 130	NHJF36150M38XTW
H-Frame, 150 A, 3P, 480 V AC 50/60 Hz - lug lug connectors		
Sensor rating (A)	Full Load Amperes Range (FLA)	Interrupting rating Standard (80 %) rated J - 65 kA
150	58 - 130	NHJL36150M38X

⁽¹⁾ Two-device solutions (these electronic motor protector circuit breakers include short circuit and overload protection):
 ■ 1 electronic motor circuit protector with a Micrologic 2.2 M electronic trip unit, plus
 ■ 1 contactor.

PowerPact J-Frame 250 A Electronic motor protector circuit breakers (UL ratings) - Two device solutions ⁽¹⁾

With factory sealed trip unit (suitable for reverse connection)

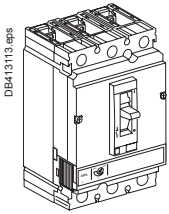

J-Frame, 250 A, 3P, 480 V AC 50/60 Hz - bus bar connectors (with metric terminal nut)		
Sensor rating (A)	Full Load Amperes Range (FLA)	Interrupting rating Standard (80 %) rated J - 65 kA
250	114 - 217	NJJF36250M38XTW
J-Frame, 250 A, 3P, 480 V AC 50/60 Hz - lug lug connectors		
Sensor rating (A)	Full Load Amperes Range (FLA)	Interrupting rating Standard (80 %) rated J - 65 kA
250	114 - 217	NJLJ36250M38X

⁽¹⁾ Two-device solutions (these electronic motor protector circuit breakers include short circuit and overload protection):
 ■ 1 electronic motor circuit protector with a Micrologic 2.2 M electronic trip unit, plus
 ■ 1 contactor.

PowerPact L-Frame 600 A Electronic motor protector circuit breakers (UL ratings) - Two device solutions ⁽¹⁾

With factory sealed trip unit (suitable for reverse connection)

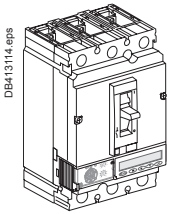

L-Frame, 600 A, 3P, 480 V AC 50/60 Hz - bus bar connectors (with metric terminal nut)		
Sensor rating (A)	Full Load Amperes Range (FLA)	Interrupting rating Standard (80 %) rated J - 65 kA
400	190 - 348	NLJF36400M38XTW
600	312 - 520	NLJF36600M38XTW
L-Frame, 600 A, 3P, 480 V AC 50/60 Hz - lug lug connectors		
Sensor rating (A)	Full Load Amperes Range (FLA)	Interrupting rating Standard (80 %) rated J - 65 kA
400	190 - 348	NLJL36400M38X
600	312 - 520	NLJL36600M38X

⁽¹⁾ Two-device solutions (these electronic motor protector circuit breakers include short circuit and overload protection):
 ■ 1 electronic motor circuit protector with a Micrologic 2.2 M electronic trip unit, plus
 ■ 1 contactor.

PowerPact automatic molded case switches

PowerPact automatic molded case switches

With factory sealed trip unit (suitable for reverse connection)

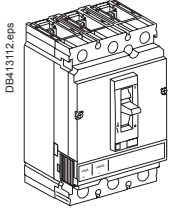

3P, 480 V AC 50/60 Hz, bus bar connector

Current rating at 40 °C (A)	Trip point	Interrupting rating Standard (80 %) rated L - 100 kA
150	2250 A	NHLF36000S15TW
250	3125 A	NJLF36000S25TW
400	4800 A	NLLF36000S40XTW
600	6600 A	NLLF36000S60XTW

PowerPact automatic molded case switches

With factory sealed trip unit (suitable for reverse connection)

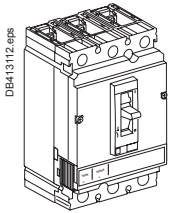

3P, 480 V AC 50/60 Hz, lug lug connector

Current rating at 40 °C (A)	Trip point	Interrupting rating Standard (80 %) rated L - 100 kA
150	2250 A	NHLL36000S15
250	3125 A	NJLL36000S25
400	4800 A	NLLL36000S40X
600	6600 A	NLLL36000S60X

L-Frame unit-mount circuit breaker

DB41315eps

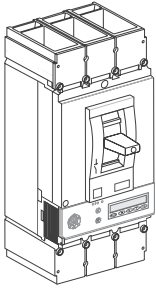

PowerPact L-Frame 600 A electronic trip UL rated 3P circuit breakers (480 V AC, 50/60 Hz)

With factory sealed trip unit suitable for reverse connection

PowerPact bus bar connectors (with metric terminal nut)

Electronic trip unit type	Trip function	Sensor rating (A)	Interrupting rating Standard (80 %) rated			
			D - 18 kA	G - 35 kA	J ⁽¹⁾ - 65 kA	L ⁽¹⁾ - 100 kA

Micrologic 3.3

Standard	LI	250 A	NLDF36250U31XTW	NLGF36250U31XTW	NLJF36250U31XTW	-
		400 A	NLDF36400U31XTW	NLGF36400U31XTW	NLJF36400U31XTW	NLLF36400U31XTW
		600 A	NLDF36600U31XTW	NLGF36600U31XTW	NLJF36600U31XTW	NLLF36600U31XTW

Micrologic 5.3 E

Energy	LSI	400 A	NLDF36400U53XTW	NLGF36400U53XTW	NLJF36400U53XTW	NLLF36400U53XTW
		600 A	NLDF36600U53XTW	NLGF36600U53XTW	NLJF36600U53XTW	NLLF36600U53XTW

PowerPact lug lug connectors

Electronic trip unit type	Trip function	Sensor rating (A)	Interrupting rating Standard (80 %) rated			
			D - 18 kA	G - 35 kA	J ⁽¹⁾ - 65 kA	L ⁽¹⁾ - 100 kA

Micrologic 3.3

Standard	LI	250 A	NLDL36250U31X	NLGL36250U31X	NLJL36250U31X	-
		400 A	NLDL36400U31X	NLGL36400U31X	NLJL36400U31X	NLLL36400U31X
		600 A	NLDL36600U31X	NLGL36600U31X	NLJL36600U31X	NLLL36600U31X

Micrologic 5.3 E

Energy	LSI	400 A	NLDL36400U53X	NLGL36400U53X	NLJL36400U53X	NLLL36400U53X
		600 A	NLDL36600U53X	NLGL36600U53X	NLJL36600U53X	NLLL36600U53X

⁽¹⁾ UL Listed/CSA Certified as current limiting circuit breakers.

Rear connection

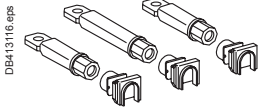

Description device		3P
Mixed rear connection kit		L-Frame
Consisting of:		32477
Short rear connections	Set of 2	2 x ⁽¹⁾ 32475
Long rear connections	Set of 2	2 x ⁽¹⁾ 32476
Short twterminal cover		32562

Plug-in version

Kit for PowerPact L

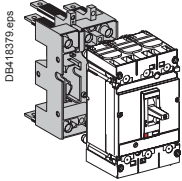

Description device		3P
Plug-in kit		L-Frame
		LV432514

Withdrawable version

Kit for PowerPact L

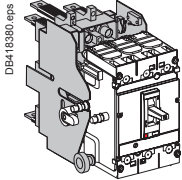

Description device		3P
Plug-in kit		L-Frame
		S32514
Fixed part of chassis		LV432532
Moving part of chassis		LV432533

Plug-in and drawout accessories

PowerPact L

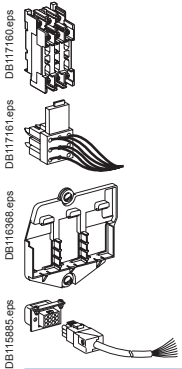

Description device		3P
Secondary disconnecting blocks - 9 wire connector		L-Frame
9-wire moving connector (for CB)		LV429273
Support for 3 moving connectors		LV432523
9-wire disconnecting harness (fixed & moving)		LV432525
2 IP4 shutters for plug-in base		LV429272
Extended escutcheon for toggle		32521
Locking device (not included)		S32534
2 position indicating switches (connected/disconnected)		LV429286
		LV429287

Mechanical lug kits for L-Frame circuit breakers

Kit comprising Al lugs for use with Al or Cu wire + terminal shield

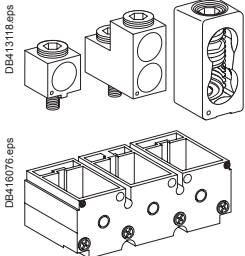

Ampere rating	Unit mount	Number of wires per lug and wire range ⁽²⁾	3P
250	■	(1) 2 AWG - 500 kcmil Al	Set of 3 AL400L61K3
400/600	■	(2) 2/0 AWG - 500 kcmil Al or Cu	Set of 3 AL600LS52K3
400/600	■	(2) 3/0 AWG - 500 kcmil Al or Cu	Set of 3 AL600LF52K3

Kit comprising mechanical lugs and 2 interphase barriers

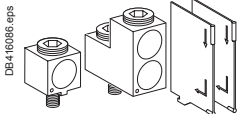

Aluminium connectors	Set of 3	LV432479
Aluminium connectors for 2 cables	Set of 3	LV432481

Control wire terminals

Busbar connection



Control tape takeoff (L-frame)	Qty per kit	
	2	29348

(1) Order two kits (two in kit x two kits for total of four).

(2) For control wire installation, use an 8 - 32 x 1/4 in. screw (not provided) into tapped control wire hole in lower left hand corner of lug.

L-Frame circuit breaker accessories

Terminal shields

Used with

DB416037.eps

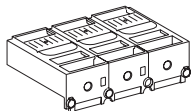

L-Frame			
Short terminal shield (3P)		1	LV432591
Long terminal shield (3P)		1	LV432593

DB416088.eps

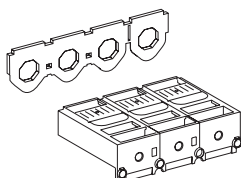

Short terminal shield (3P) with gasket		1	LV433683
--	--	---	----------

Rotary operated handles

DB111480.eps

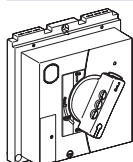

			L-Frame
Direct mounted			
Standard black handle (handle only)			LV432597
Standard black handle with			LV432597
	One early-break switch		+ LV432605
	Two early-make switches		+ LV429346
Red handle on yellow bezel (handle only)			LV432599
MCC conversion			LV432606
CNOMO conversion			LV432602
Red handle on yellow bezel with			LV432599
	One early-break switch		+ LV432605
	Two early-make switches		+ LV429346
Door mounted			
Standard black handle (handle only)			LV432598
Standard black handle with			LV432598
	Two early-make switches		+ LV429346
Red handle on yellow bezel (handle only)			LV432600
Telescoping			
Telescoping			LV432603
Accessories for direct or extended rotary handle			
Indication auxiliary	1 early-break contact		LV432605
	2 early-make contacts		LV429346

Locking systems

DB413122.eps

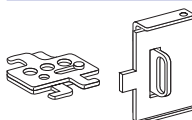

			L-Frame
Handle padlocking device ⁽¹⁾	Removable (lock OFF only)		29370
	Fixed (lock OFF or ON)		32631
	Fixed (lock OFF only)		NJPAF
Locking of rotary handle	Keylock adapter (keylock not included)		LV432604

Installation accessories

Front-panel escutcheon IP40

DB416072.eps



			L-Frame
For toggle			32556

Lead - Sealing accessories

DB115615.eps



Bay of accessories			LV429375
--------------------	--	--	----------

(1) Rotary handle has integral padlocking capability.

Electrical auxiliaries

Auxiliary contacts (changeover)

DB112254.eps



OF or SD or SDE or SDV	29450
OF or SD or SDE or SDV low level	29452

SDx output module for Micrologic electronic trip unit

DB112275.eps

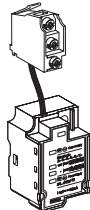

SDx module 24/415 V AC/DC	LV429532
---------------------------	----------

Voltage releases

DB111454.eps



	Voltage	MX	MN
AC	24 V 50/60 Hz	LV429384	LV429404
	48 V 50/60 Hz	LV429385	LV429405
	110-130 V 50/60 Hz	LV429386	LV429406
	220-240 V 50/60 Hz and 208-277 V 60 Hz	LV429387	LV429407
	380-415 V 50 Hz and 440-480 V 60 Hz	LV429388	LV429408
	525 V 50 Hz and 600 V 60 Hz	LV429389	LV429409
DC	12 V	LV429382	LV429402
	24 V	LV429390	LV429410
	30 V	LV429391	LV429411
	48 V	LV429392	LV429412
	60 V	LV429383	LV429403
	125 V	LV429393	LV429413
	250 V	LV429394	LV429414
MN 48 V DC 50/60 Hz			
	MN 48 V DC		LV429412
MN 110-130 V DC 50/60 Hz			
	MN 125 V DC		LV429413
MN 220-250 V 50/60 Hz			
	MN 250 V DC		LV429414

L-Frame circuit breaker accessories

Motor mechanism

Motor mechanism module

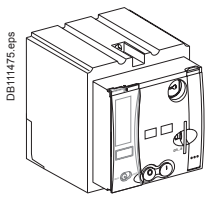
	AC	Voltage		MT400-630
		48-60 V 50/60 Hz		LV432639
		110-130 V 50/60 Hz		LV432640
		220-240 V 50/60 Hz and 208-277 V 60 Hz		LV432641
		380-415 V 50 Hz		LV432642
		440-480 V 60 Hz		LV432647
	DC	24-30 V		LV432643
		48-60 V		LV432644
		110-130 V		LV432645
		250 V		LV432646
Operation counter			LV432648	

Communicating motor mechanism module

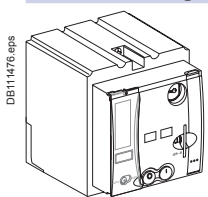
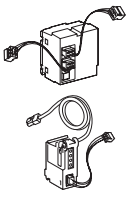

	Motor mechanism module	220-240 V 50/60 Hz	MTc 400/630	LV432652
	+			
	Breaker status Communication Module	BSCM		LV434205
	+			
	NSX cord	Wire length L = 1.3 m		LV434201
		Wire length L = 3 m		LV434202
		U > 480 V AC wire length L = 0.35 m		LV434204

Trip unit accessories

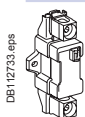
External neutral current transformer

	400 - 600 A	S432575

Communication option

	IFE	Ethernet interface for LV breaker	LV434010
		Ethernet interface for LV breakers and gateway	LV434011
	IFM Modbus-SL interface module		TRV00210
	I/O application module		LV434063
	User guide IFE		DOCA0084EN-00
	User guide I/O application module		DOCA0055EN-00

Monitoring and control (remote operation)

Circuit breaker accessories

	Breaker Status Control Module	BSCM	LV434205
---	-------------------------------	------	----------

ULP display module ⁽¹⁾

	Switchboard front display module FDM121		TRV00121
	FDM mounting accessory (diameter 22 mm)		TRV00128



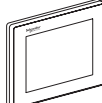



Ethernet display module

	Switchboard front display module FDM128		LV434128
---	---	--	----------

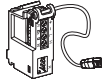
ULP communication module

	Modbus interface	Modbus SL communication interface module	TRV00210
---	------------------	--	----------

ULP wiring accessories

	NSX cord L = 1.3 m (4.27 ft) V ≤ 480 V		LV434201
	NSX cord L = 3 m (9.84 ft) V ≤ 480 V		LV434202
	NSX cord L = 1.3 m (4.27 ft) V > 480 V AC		LV434204
	NSX cord L = 3 m (9.84 ft) V > 480 V		LV434303
	10 stacking connectors for communication interface modules		TRV00217
	10 Modbus line terminators		VW3A8306DRC
	RS 485 roll cable (4 wires, length 60 m)		50965
	5 RJ45 connectors female/female		TRV00870
	10 ULP line terminators		TRV00880
	10 RJ45/RJ45 male cord L = 0.3 m		TRV00803
	10 RJ45/RJ45 male cord L = 0.6 m		TRV00806
	5 RJ45/RJ45 male cord L = 1 m		TRV00810
	5 RJ45/RJ45 male cord L = 2 m		TRV00820
	5 RJ45/RJ45 male cord L = 3 m		TRV00830
	1 RJ45/RJ45 male cord L = 5 m		TRV00850
	2 wires RS 485 insulated repeated		TRV00211

⁽¹⁾ For measurement display with Micrologic A and E or status display with BSCM.

Monitoring and control (remote operation)

Power supply modules

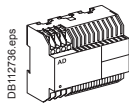
	External power supply module	24-30 V DC	54440
	24 V DC-1 A OVC IV	48-60 V DC	54441
		100-125 V AC	54442
		110-130 V AC	54443
		200-240 V AC	54444
		380-415 V AC	54445

Battery module

	24 V DC battery module	54446
---	------------------------	-------

Test tool and software

Test tool

	Pocket battery for Micrologic	LV434206
---	-------------------------------	----------

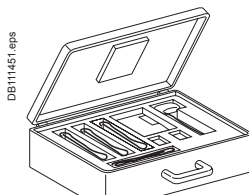
	Maintenance case	TRV00910
	Comprising:	
	- USB maintenance interface	
	- Power supply	
	- Micrologic cord	
	- USB cord	
	- RJ45/RJ45 male cord	

	Spare USB maintenance interface	TRV00911
---	---------------------------------	----------

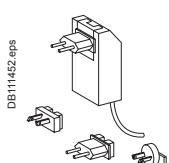
	Spare power supply 110-240 V AC	TRV00915
---	---------------------------------	----------

	Spare Micrologic cord for USB maintenance interface	TRV00917
---	---	----------

Software

	Configuration and setting software RSU	LV4ST100 ⁽¹⁾
	Test software LTU	LV4ST121 ⁽¹⁾

⁽¹⁾ Downloadable from <http://www.schneider-electric.com>.

IEC busbar supports and accessories

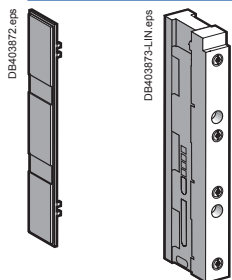

		Sale in ind.Q.	
3-pole	For 12, 15, 20, 25, 30 x 5/10 mm ² busbars	10	LA9ZX01495
	End covers for 3-pole busbar support	10	LA9ZX01573

LA9ZX01573 LA9ZX01495

UL busbar supports and accessories

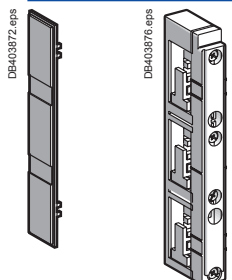

		Sale in ind.Q.	
3-pole	For 12, 20, 30 x 5/10 mm busbars	10	LA9ZX01508
	Base plate 240 x 700	2	LA9ZX01515
	End covers for busbar support	10	LA9ZX01573

LA9ZX01573 LA9ZX01508

Other accessories

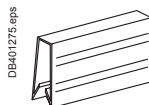

		Sale in ind.Q.	
Covers, length 1 m	For 12-30 x 5 mm ² busbars	Set of 10	LA9ZX01244
	For 12-30 x 10 mm ² busbars	Set of 10	LA9ZX01245

For PowerPact 3P circuit breakers

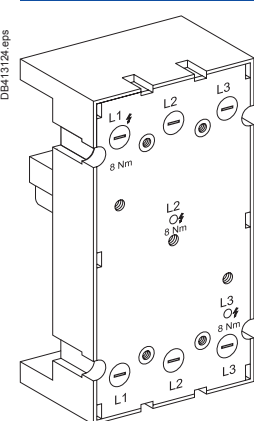

Ratings 600 V (UL) - 690 V AC (IEC)		Sale in ind. Q.	
	Mounting plate for H frame circuit breakers 100-250 A (104 x 190 x 63)	1	LA9ZA32600
	Mounting plate for J frame circuit breakers 250 A (104 x 190 x 63)	1	LV429372
	Mounting plate for L frame circuit breakers 400-630 A (139 x 270 x 63)	1	LV432623

Terminals

DB400227.eps

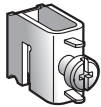

LA9ZX01285

			Sale in ind. Q.	
One-pole for flat bars, 5 mm	270 A (I max) Capacity 4-35 mm ²	50	LA9ZX01285	
	400 A (I max) Capacity 16-70 mm ²	25	LA9ZX01287	
3P cover, width 84 mm		10	LA9ZX01413	

DB400243.eps

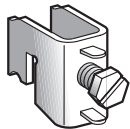

LA9ZX01287

Terminals on mounting plate

DB400226.eps

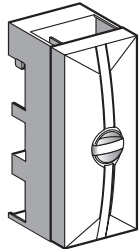

LA9ZX01243

			Sale in ind. Q.	
3P, on mounting plate + cover, for 12 x 5 to 30 x 10 busbars	440 A (I max) Capacity 35-120 mm ²	1	LA9ZX01243	

Connection module

DB400240.eps

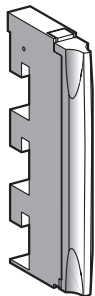

LA9ZX01563

			Sale in ind. Q.	
3P, spring terminal connection + cover, for busbars of 12 x 5 to 30 x 10	80 A (I max) Capacity 1.5-16 mm ²	8	LA9ZX01563	

Connection by connectors

		LA9ZX01285		LA9ZX01287		LA9ZX01243		LA9ZX01563	
		Min.	Max.	Min.	Max.	Min.	Max.	Min.	Max.
Flexible wire	mm ²	4	35	16	70	35	120	1.5	16
Multi-strand wire	mm ²	4	35	16	70	35	120	1.5	16
Rigid wire	mm ²	4	35	–	–	–	–	1.5	16
Tightening torque	N.m	... x 5 Supplied without cover		... x 5 Supplied without cover		... x 5-10		... x 5-10	

<i>Functions and characteristics</i>	A-1
<i>Installation recommendations</i>	B-1
<i>Dimensions</i>	C-1
<i>Wiring diagrams</i>	D-1
<i>Additional characteristics</i>	E-1
<i>Catalogue numbers</i>	F-1
Accessories	G-2
Circuit-breaker characteristics (IEC 60947-2)	G-2
Communication	G-4
Components	G-6
Controls	G-6
Discrimination / Cascading	G-6
Environment	G-7
Harmonics	G-8
Measurements	G-9
Protection	G-10
Relays and auxiliary contacts	G-10
Switchgear	G-10
Three-phase asynchronous motors and their protection	G-11
Trip units	G-12

For each major section (Accessories, Switchgear, etc.) and for each item (Adapter for plug-in base, Connection terminal, etc.), this glossary provides:

- the reference standard
- the standardised IEC symbol
- the definition.

Text in quotation marks is drawn from the standards.

Accessories

Adapter for plug-in base

The adapter is a plastic component that can be installed upstream and/or downstream of the plug-in base and enables use of all the connection accessories of the fixed device.

Bare-cable connector

Conducting part of the circuit breaker intended for connection to power circuits. On Powerpact, it is an aluminium part that screws to the connection terminals of the circuit breaker. There are one or more holes (single or multiple cable connector) for the ends of bare cables.

Connection terminals

Flat copper surface, linked to the conducting parts of the circuit breaker and to which power connections are made using bars, connectors or lugs.

Spreaders

Set of three (3P device) flat, conducting parts made of aluminium. They are screwed to the circuit-breaker terminals to increase the pitch between poles.

Circuit-breaker characteristics (IEC 60947-2)

Breaking capacity

Value of prospective current that a switching device is capable of breaking at a stated voltage under prescribed conditions of use and behaviour. Reference is generally made to the ultimate breaking capacity (I_{cu}) and the service breaking capacity (I_{cs}).

Degree of protection (IP) IEC 60529

Defines device protection against the penetration of solid objects and liquids, using two digits specified in standard IEC 60259. Each digit corresponds to a level of protection, where 0 indicates no protection.

- First digit (0 to 6): protection against penetration of solid foreign objects. 1 corresponds to protection against objects with a diameter > 50 mm, 6 corresponds to total protection against dust.

- Second digit (0 to 8): protection against penetration of liquids (water). 1 corresponds to protection against falling drops of water (condensation), 8 corresponds to continuous immersion.

The enclosure of Powerpact circuit breakers provides a minimum of IP40 (protection against objects > 1 mm) and can reach IP56 (protection against dust and powerful water jets) depending on the installation conditions.

Degree of protection against external mechanical impacts (IK)

Defines the aptitude of an object to resist mechanical impacts on all sides, indicated by a number from 0 to 10 (standard IEC 62262). Each number corresponds to the impact energy (in Joules) that the object can handle according to a standardised procedure.

0 corresponds to no protection, 1 to an impact energy of 0.14 Joules, 10 to an impact energy of 20 Joules. Powerpact provide IK07 (2 Joules) and can provide IK08 (5 Joules) depending on the installation conditions.

Durability

The term "durability" is used in the standards instead of "endurance" to express the expectancy of the number of operating cycles which can be performed by the equipment before repair or replacement of parts. The term "endurance" is used for specifically defined operational performance.

Electrical durability IEC 60947-1

With respect to its resistance to electrical wear, equipment is characterised by the number of on-load operating cycles, corresponding to the service conditions given in the relevant product standard, which can be made without replacement.

Frame size

"A term designating a group of circuit breakers, the external physical dimensions of which are common to a range of current ratings. Frame size is expressed in amperes corresponding to the highest current rating of the group. Within a frame size, the width may vary according to the number of poles. This definition does not imply dimensional standardization."

Powerpact has three frame sizes covering 150 to 250 A and 400 to 600 A.

Insulation class	<p>Defines the type of device insulation in terms of earthing and the corresponding safety for user, in one of three classes.</p> <ul style="list-style-type: none"> ■ Class I. The device is earthed. Any electrical faults, internal or external, or caused by the load, are cleared via the earthing circuit, thus ensuring user safety. ■ Class II. The device is not connected to a protective conductor. User safety is ensured by reinforced insulation around the live parts (an insulating case and no contact with live parts, i.e. plastic buttons, moulded connections, etc.) or double insulation. ■ Class III. The device may be connected only to SELV (safety extra-low voltage) circuits. The Powerpact are class II devices (front) and may be installed through the door in class II switchboards (standards IEC 61140 and IEC 60664-1), without reducing insulation, even with a rotary handle or motor mechanism module.
Making capacity	Value of prospective making current that a switching device is capable of making at a stated voltage under prescribed conditions of use and behaviour. Reference is generally made to the short-circuit making capacity Icm.
Maximum break time	Maximum time after which breaking is effective, i.e. the contacts separated and the current completely interrupted.
Mechanical durability	With respect to its resistance to mechanical wear, equipment is characterised by the number of no-load operating cycles which can be effected before it becomes necessary to service or replace any mechanical parts.
Non-tripping time	This is the minimum time during which the protective device does not operate in spite of pick-up overrun, if the duration of the overrun does not exceed the corresponding voluntary time delay.
Pollution degree of environment conditions IEC 60947-1 IEC 60664-1	<p>"Conventional number based on the amount of conductive or hygroscopic dust, ionized gas or salt and on the relative humidity and its frequency of occurrence, resulting in hygroscopic absorption or condensation of moisture leading to reduction in dielectric strength and/or surface resistivity". Standard IEC 60947-1 distinguishes four pollution degrees.</p> <ul style="list-style-type: none"> ■ Degree 1. No pollution or only dry, non-conductive pollution occurs. ■ Degree 2. Normally, only non-conductive pollution occurs. Occasionally, however, a temporary conductivity caused by condensation may be expected. ■ Degree 3. Conductive pollution occurs, or dry, non-conductive pollution occurs which becomes conductive due to condensation. ■ Degree 4. The pollution generates persistent conductivity caused, for instance, by conductive dust or by rain or snow. Powerpact meets degree 3, which corresponds to industrial applications.
Prospective short-circuit current	Current that would flow through the poles if they remained fully closed during the short-circuit.
Rated current (In)	This is the current that the device can carry continuously with the contacts closed and without abnormal temperature rise.
Rated impulse withstand voltage (Uimp)	"The peak value of an impulse voltage of prescribed form and polarity which the equipment is capable of withstanding without failure under specified conditions of test and to which the values of the clearances are referred. The rated impulse withstand voltage of an equipment shall be equal to or higher than the values stated for the transient overvoltages occurring in the circuit in which the equipment is fitted".
Rated insulation voltage (Ui)	"The rated insulation voltage of an equipment is the value of voltage to which dielectric tests and creepage distances are referred. In no case shall the maximum value of the rated operational voltage exceed that of the rated insulation voltage".
Rated operational current (Ie)	"A rated operational current of an equipment is stated by the manufacturer and takes into account the rated operational voltage, the rated frequency, the rated duty, the utilization category and the type of protective enclosure, if appropriate".
Rated operational voltage (Ue)	<p>"A value of voltage which, combined with a rated operational current, determines the application of the equipment and to which the relevant tests and the utilisation categories are referred. For multipole equipment, it is generally stated as the voltage between phases".</p> <p>This is the maximum continuous voltage at which the equipment may be used.</p>

Rated short-time withstand current (Icw)	"Value of short-time withstand current, assigned to the equipment by the manufacturer, that the equipment can carry without damage, under the test conditions specified in the relevant product standard". Generally expressed in kA for 0.5, 1 or 3 seconds. This is an essential characteristic for air circuit breakers. It is not significant for moulded-case circuit breakers for which the design targets fast opening and high limiting capacity.
Service breaking capacity (Ics)	Expressed as a percentage of Icu, it provides an indication on the robustness of the device under severe conditions. It is confirmed by a test with one opening and one closing/opening at Ics, followed by a check that the device operates correctly at its rated current, i.e. 50 cycles at In, where temperature rise remains within tolerances and the protection system suffers no damage.
Short-circuit making capacity (Icm)	Value indicating the capacity of the device to make and carry a high current without repulsion of the contacts. It is expressed in kA peak.
Suitability for isolation	<p>This capability means that the circuit breaker meets the conditions below.</p> <ul style="list-style-type: none"> ■ In the open position, it must withstand, without flashover between the upstream and downstream contacts, the impulse voltage specified by the standard as a function of the Uimp indicated on the device. ■ It must indicate contact position by one or more of the following systems: <ul style="list-style-type: none"> □ position of the operating handle □ separate mechanical indicator □ visible break of the moving contacts ■ Leakage current between each pole, with the contacts open, at a test voltage of 1.1 x the rated operating voltage, must not exceed: <ul style="list-style-type: none"> □ 0.5 mA per pole for new devices □ 2 mA per pole for devices already subjected to normal switching operations □ 6 mA, the maximum value that must never be exceeded. ■ It must not be possible to install padlocks unless the contacts are open. Locking in the closed position is permissible for special applications. Powerpact complies with this requirement by positive contact indication.
Suitable for isolation with positive contact indication (see also Suitability for isolation, page G2)	<p>Suitability for isolation is defined here by the mechanical reliability of the position indicator of the operating mechanism, where:</p> <ul style="list-style-type: none"> ■ the isolation position corresponds to the O (OFF) position ■ the operating handle cannot indicate the "OFF" position unless the contacts are effectively open. <p>The other conditions for isolation must all be fulfilled:</p> <ul style="list-style-type: none"> ■ locking in the open position is possible only if the contacts are effectively open ■ leakage currents are below the standardised limits ■ overvoltage impulse withstand between upstream and downstream connections.
Ultimate breaking capacity (Icu)	Expressed in kA, it indicates the maximum breaking capacity of the circuit breaker. It is confirmed by a test with one opening and one closing/opening at Icu, followed by a check that the circuit is properly isolated. This test ensures user safety.

Communication.....

Acti 9 Smartlink Ethernet	Acti 9 Smartlink Ethernet collects data from Smartlink Modbus and transfers them via the Ethernet network.
Acti 9 Smartlink Modbus	Acti 9 Smartlink Modbus is used to transfer data from Acti 9 devices to a PLC or monitoring system via the communication system: Modbus serial line.
BSCM (Breaker status and control module)	The optional BSCM for Compact NSX is used to acquire device status indications and control the communicating remote-control function. It includes a memory used to manage the maintenance indicators. It serves as a converter between the analog outputs of the device indication contacts (O/F, SD, SDE) and the digital communicating functions.
Com'X 200 energy server	<p>Com'X 200 energy server is a compact, plug-and-play data logger that merges seamlessly with the Smart Panels energy management solution. It consolidates inputs from analog environmental sensors (e.g. temperature), digital readers (e.g. pulsed signals from smart energy or water meters, load running hours), and energy management equipment running over the Modbus protocol.</p> <p>Designed for ease of implementation, data can be transmitted securely via Ethernet, Wi-Fi, or GPRS to any energy management platforms. The Com'X 200 energy server is scalable and can be easily adaptable to accommodate future upgrades. Com'X 200 is a perfect fit with our energy management services, enabling visualization, tracking, and analysis of energy data to support optimization of energy performance and cost management.</p>

Ethernet TCP/IP

(Transmission Control Protocol / Internet Protocol)

Ethernet is a very common network protocol and complies with IEEE standard 802.3. Ethernet TCP/IP is the protocol that brings web functions to Ethernet networks. Most PCs have an Ethernet 10/100 card (10 or 100 Mbit/s) for connection to the internet. Data communicated from Compact NSX via Modbus are accessible on a PC via a TCP/IP-Modbus gateway such as MPS100 or EGX100.

FDM121 switchboard display

An FDM121 switchboard display unit can be connected to a ULP IMU using a prefabricated cord to display all measurements, alarms, histories and event tables, maintenance indicators, management of installed devices on a screen. The result is a veritable 96 x 96 mm Power Meter.

The FMD121 display unit requires a 24 V DC power supply.

The FDM121 is a switchboard display unit that can be integrated in the Compact NSX100 to 630 A, Powerpact H/J/L/P/R, Compact NS or Masterpact systems.

FDM128 switchboard display

The FDM128 is a large display, but requires very little depth. The anti-glare graphic screen is backlit for very easy reading even under poor ambient lighting and at sharp angles.

**IFE Ethernet interface,
IFE Ethernet interface + gateway**

The IFE Ethernet interface for LV circuit breaker enables an intelligent modular unit (IMU), for example a Masterpact NT/NW or Compact NSX circuit breaker to be connected to an Ethernet network.

IFM Module interface Modbus

This module required for connection to the network, contains the Modbus address (1 to 99) declared by the user via the two dials in front. It automatically adapts (baud rate, parity) to the Modbus network in which it is installed.

It is equipped with a lock-out switch to enable or disable operations involving writing to Micrologic, i.e. reset, counter reset, setting modifications, device opening and closing commands, etc. There is a built-in test function to check the connections of the Modbus interface module with the Micrologic and FDM121 display unit.

I/O application module

The I/O (Input/Output) application module for LV breaker is part of an ULP system with built-in functionalities and applications to enhance the application needs.

The ULP system architecture can be built without any restrictions using the wide range of circuit breakers.

The I/O application module is compliant with the ULP system specifications.

Two I/O application modules can be connected in the same ULP network.

Network

Set of communicating devices that are interconnected by communication lines in order to share data and resources.

Open protocol

A protocol for system communication, interconnection or data exchange for which technical specifications are public, i.e. there are no restrictions on access or implementation. An open protocol is the opposite of a proprietary protocol.

Protocol

Standardised specification for dialog between digital components that exchange data. It is an operating mode based on the length and structure of binary words and it must be used by all the components exchanging data between themselves.

Communication is not possible without using a protocol.

RJ45 connector

Universal, 8-wire connector that is widely used in digital communication networks.

The RJ45 connector is used to interconnect computer equipment (Ethernet, Modbus, etc.), telephones and audiovisual equipment.

RS485 Modbus

Modbus is the most widely used communication protocol in industrial networks. It operates in master-slave mode. An RS485 multipoint link connects the master and slaves via a pair of wires offering throughputs of up to 38400 bits/second over distances up to 1200 m). The master cyclically polls the slaves which send back the requested information.

The Modbus protocol uses frames containing the address of the targeted slave, the function (read, write), the datum and the CRC (cyclical redundancy check).

SdTAM

Relay module with two static outputs specifically for the motor-protection Micrologic trip units 1 M, 2 M and 6 E-M. An output, linked to the contactor controller, opens the contactor when an overload or other motor fault occurs, thus avoiding opening of the circuit breaker. The other output stores the opening event in memory.

SDx

Relay module with two outputs that remotes the trip or alarm conditions of Compact NSX circuit breakers equipped with a Micrologic electronic trip unit.

Static output

Output of a relay made up of a thyristor or triac electronic component. The low switching capability means that a power relay is required.

This is the case for the SDx and SdTAM outputs.

ULP (Universal Logic Plug)

Connection system used by Compact NSX to communicate information to the Modbus interface via a simple RJ45 cable. Compatible modules are indicated by the symbol opposite.

Components.....

ASIC (Application Specific Integrated Circuit)

Integrated circuit designed, built and intended for a specific application. It carries out repetitive sequences of instructions engraved in the silicon chip. For that reason, it is extremely reliable because it cannot be modified and is not affected by environment conditions.

Micrologic trip units use an ASIC for the protection functions. The ASIC cyclically polls the network status at a high frequency, using the values supplied by captors. Comparison with the settings forms the basis for orders to the electronic trip units.

Microprocessor

A microprocessor is a more general purpose device than an ASIC. In Micrologic, a microprocessor is used for measurements and it can be programmed. It is not used for the main protection functions that are carried out by the ASIC.

Controls

Communicating motor mechanism

For Powerpact remote control via the communication system, a communicating motor mechanism is required. Except for the communication function, it is identical to the standard motor mechanism module and connects to and controlled by the BSCM module.

CNOMO machine-tool rotary handle

Handle used for machine-tool control enclosures and providing IP54 and IK08.

Direct rotary handle

This is an optional control handle for the circuit breaker. It has the same three positions I (ON), O (OFF) and TRIPPED as the toggle control. It provides IP40, IK07 and the possibility, due to its extended travel, of using early-make and early-break contacts. It maintains suitability for isolation and offers optional locking using a keylock or a padlock.

Emergency off

In a circuit equipped with a circuit breaker, this function is carried out by an opening mechanism using an MN undervoltage release or an MX shunt release in conjunction with an emergency off button.

Extended rotary handle

Rotary handle with an extended shaft to control devices installed at the rear of switchboards. It has the same characteristics as direct rotary handles. It offers multiple locking possibilities using a keylock, a padlock or a door interlock.

Failsafe remote tripping

Remote tripping is carried out by an opening mechanism using an MN undervoltage release in conjunction with an emergency off button. If power is lost, the protection device opens the circuit breaker.

Discrimination / Cascading.....

Cascading

Cascading implements the current-limiting capacity of a circuit breaker, making it possible to install downstream circuit breakers with lower performance levels.

The upstream circuit breaker reduces any high short-circuit currents. This makes it possible to install downstream circuit breakers with breaking capacities less than the prospective short-circuit current at their point of installation.

The main advantage of cascading is to reduce the overall cost of switchgear.

Because the current is limited throughout the circuit downstream of the limiting circuit breaker, cascading applies to all the devices located downstream.

Current discrimination

Discrimination based on the difference between the current-protection settings of the circuit breakers. The difference in settings between two successive circuit breakers in a circuit must be sufficient to allow the downstream breaker to clear the fault before the upstream breaker trips.

Discrimination

Discrimination is ensured between upstream and downstream circuit breakers if, when a fault occurs, only the circuit breaker placed immediately upstream of the fault trips.

Discrimination is the key to ensuring the continuity of service of an installation.

Energy discrimination

This function is specific to Powerpact and supplements the other types of discrimination.

Partial discrimination

Discrimination is partial if the conditions for total discrimination are not met up to the ultimate short-circuit current I_{cu} , but only up to a lesser value. This value is called the discrimination limit. If a fault exceeds the discrimination limit, both circuit breakers trip.

Time discrimination

Discrimination based on the difference between the time-delay settings of the circuit breakers. The upstream trip unit is delayed to provide the downstream breaker the time required to clear the fault.

Total discrimination

Total discrimination is ensured between upstream and downstream circuit breakers if, for all fault values, from overloads up to solid short-circuits, only the downstream circuit breaker trips and the upstream circuit breaker remains closed.

Zone selective interlocking (ZSI)

A number of circuit breakers with Micrologic electronic trip units are interconnected one after another by a pilot wire. In the event of a short-time or ground fault:

- in the absence of information from downstream, the circuit breaker directly concerned by the fault (i.e. located just upstream of the fault) shifts to the shortest time delay and sends a signal upstream
- the upstream device, on receiving the signal from the downstream device, maintains its normal time delay.

In this manner, the fault is cleared rapidly by the circuit breaker closest to the fault.

Environment.....

EMC (Electromagnetic compatibility)

EMC is the capacity of a device not to disturb its environment during operation (emitted electromagnetic disturbances) and to operate in a disturbed environment (electromagnetic disturbances affecting the device). The standards define various classes for the types of disturbances. Micrologic trip units comply with annexes F and J in standard IEC IE60947-2.

Power loss

Pole resistance

The flow of current through the circuit-breaker poles produces Joule-effect losses caused by the resistance of the poles.

Product environmental profile (PEP)

LCA: Life-cycle assessment
ISO 14040

An assessment on the impact of the construction and use of a product on the environment, in compliance with standard ISO 14040, Environmental management, life-cycle assessment (LCA), principles and framework.

For Powerpact, this assessment is carried out using the standardised EIME (Environmental Impact and Management Explorer) software, which makes possible comparisons between the products of different manufacturers.

It includes all stages, i.e. manufacture, distribution, use and end of life, with set usage assumptions:

- use over 20 years at a percent load of 80 % for 14 hours per day and 20 % for ten hours

- according to the European electrical-energy model.

It provides the information presented below.

- Materials making up the product: composition and proportions, with a check to make sure no substances forbidden by the RoHS directive are included.

- Manufacture: on Schneider Electric production sites that have set up an environmental management system certified ISO 14001.

- Distribution: packaging in compliance with the 94/62/EC packaging directive (optimised volumes and weights) and optimised distribution flows via local centres.

- Use: no aspects requiring special precautions for use. Power lost through Joule effect in Watts (W) must be < 0.02 % of total power flowing through the circuit breaker. Based on the above assumptions, annual consumption from 95 to 200 kWh.

- End of life: products dismantled or crushed. For Powerpact, 81 % of materials can be recycled using standard recycling techniques. Less than 2 % of total weight requires special recycling.

Product environmental profile (PEP)

Environmental indicators

Environmental indicators are also frequently used for the PEP (sheet available on request for Powerpact):

- Depletion of natural resources
- Depletion of energy
- Depletion of water
- Potential for atmospheric warming (greenhouse effect)
- Potential for stratospheric ozone depletion
- Creation of atmospheric ozone (ozone layer)
- Acidification of air (acid rain)
- Production of hazardous waste.

RoHS directive
(Restriction of Hazardous substances)

European directive 2002/95/EC dated 27 January 2003 aimed at reducing or eliminating the use of hazardous substances. The manufacturer must attest to compliance, without third-party certification. Circuit breakers are not included in the list of concerned products, which are essentially consumer products. That notwithstanding, Schneider Electric decided to comply with the RoHS directive. Powerpact products are designed in compliance with RoHS and do not contain (above the authorised levels) lead, mercury, cadmium, hexavalent chromium or flame retardants (polybrominated biphenyls PBB and polybrominated diphenyl ether PBDE).

Safety clearances

When installing a circuit breaker, minimum distances (safety clearances) must be maintained between the device and panels, bars and other protection systems installed nearby. These distances, which depend on the ultimate breaking capacity, are defined by tests carried out in accordance with standard IEC 60947-2.

Temperature derating

An ambient temperature varying significantly from 40 °C can modify operation of magnetic or thermal-magnetic protection functions. It does not affect electronic trip units. However, when electronic trip units are used in high-temperature situations, it is necessary to check the settings to ensure that only the permissible current for the given ambient temperature is let through.

Vibration withstand
IEC 60068-2-6

Circuit breakers are tested in compliance with standard IEC 60068-2-6 for the levels required by merchant-marine inspection organisations (Veritas, Lloyd's, etc.):

- 2 to 13.2 Hz: amplitude of ±1 mm
- 13.2 to 100 Hz: constant acceleration of 0.7 g.

WEEE directive
(Waste of Electrical and Electronic Equipment)

European directive on managing the waste of electrical and electronic equipment. Circuit breakers are not included in the list of concerned products. However, Powerpact products respect the WEEE directive.

Harmonics.....

Current harmonics

Non-linear loads cause harmonic currents that flow in the 50 Hz (or 60 Hz) distribution system. Total harmonic current is the sum of sinusoidal AC currents for which the rms values can be measured and broken down into:

- the fundamental current at the 50/60 Hz frequency of the distribution system, with an rms value of I_{H_1}
- harmonic currents with whole, odd multiples (3, 5, 7, etc.) of the 50/60 Hz frequency, called the third-order, fifth-order, etc. harmonics. For example, I_{H_3} , the third-order harmonic at 150/180 Hz, I_{H_5} , the fifth-order harmonic at 250/300 Hz, etc. The presence of harmonics in the system must be monitored and limited because it results in temperature rise, currents in the neutral (caused by the third-order harmonics and multiples), malfunctions of sensitive electronic devices, etc. Micrologic E trip units take into account harmonics up to order 15 in the THDI and THDU calculations.

Non-linear load

Systems producing harmonics are present in all industrial, commercial and residential sectors. Harmonics are caused by non-linear loads. A load is said to be non-linear when the current drawn does not have the same waveform as the supply voltage. Typically, loads using power electronics are non-linear. Examples of non-linear loads include computers, rectifiers, variable-speed drives, arc furnaces and fluorescent lighting.

Total harmonic distortion of current (THDI)

THDI characterises the distortion of the current wave by harmonics. It indicates the quantity of harmonics in the resulting waveform. It is expressed in percent. The higher the THDI, the more the current is distorted by harmonics. THDI should remain below 10 %. Above that level, there is said to be harmonic pollution that is considered severe when it rises above 50 %.

Total harmonic distortion of voltage (THDU)

THDU characterises the distortion of the voltage wave by harmonics. It indicates the quantity of harmonics in the resulting waveform. It is expressed in percent. The higher the THDU, the more the system voltage is distorted by harmonics. It is advised not to exceed 5 % for low-voltage systems.

Voltage harmonics

For each current harmonic I_{Hk} , there is a voltage harmonic U_{Hk} of the same order k , where the resulting voltage is the sum of the two waves.
The voltage wave is therefore distorted with respect to the standard sinusoidal wave.

Measurements

Contact wear

Each time Powerpact opens, the Micrologic 5/6 trip unit measures the interrupted current and increments the contact-wear indicator as a function of the interrupted current, according to test results stored in memory.

Current transformer with iron-core toroid

It is made up of a coil wound around an iron frame through which a power busbar runs. The current flowing in the bar, on passing through the sensor, induces a magnetic field that reverses for each half period. This variation in the field in turn creates an induced current in the coil. This current is proportional to the current flowing in the bar. It is sufficient to supply the measurement electronics.
The disadvantage of iron-core measurement current transformers (CT) is that they rapidly saturate for currents > 10 In.

Current transformer with Rogowski toroid or air-core CT

It is made up of a coil without an iron frame, through which a power busbar runs. The output voltage at the coil terminals is proportional to the current flowing through the bar. The result is a current transformer (CT) with a voltage output. The advantage is that it never saturates whatever the primary current and thus enables measurement of high currents. The output is however a very low current that is too low to supply the measurement electronics.
For Micrologic, Rogowski CTs measure the current and a second CT, with an iron core, provides the electrical supply.

Demand current, demand power and peak values

Average of the instantaneous current or power values over an adjustable fixed or sliding time interval. The highest value observed over the time interval is the peak value. The time interval runs from the last reset.

Instantaneous current

True rms value of the current measured by the current transformers over a sliding time interval. Available on Micrologic 5/6 E.

Instantaneous voltage

True rms value of the voltage measured by the voltage sensors over a sliding time interval. Available on Micrologic 5/6 E.

Maximeters/minimeters

Micrologic 5/6 E can record the minimum and maximum values of electrical parameters over set time periods.

Overvoltage category (OVC - Overvoltage category) IEC 60947-1. Annex H

Standard IEC 60664-1 stipulates that it is up to the user to select a measurement device with a sufficient overvoltage category, depending on the network voltage and the transient overvoltages likely to occur.

Four overvoltage categories define the field of use for a device.

- Cat. I. Devices supplied by a SELV isolating transformer or a battery.
- Cat. II. Residential distribution, handheld or laboratory tools and devices connected to standardised 2P + earth electrical outlets (230 V).
- Cat. III. Industrial distribution, fixed distribution circuits in buildings (main low voltage switchboards, rising mains, elevators, etc.).
- Cat. IV. Utility substations, overhead lines, certain industrial equipment.

Percent load

Percentage of current flowing through the circuit breaker with respect to its rated current. Micrologic 6 E-M offers this information and can sum it over the total operating time to provide the load profile for the following ranges, 0 to 49 %, 50 to 79 %, 80 to 89 % and ≥ 90 %.

Phase sequence

The order in which the phases are connected (L1, L2, L3 or L1, L3, L2) determines the direction of rotation for three-phase asynchronous motors. Micrologic 6 E-M trip units provide this information.

Power and energy metering (consumption)

The digital electronics in Micrologic 5/6 E calculate the instantaneous power levels, apparent (S in kVA), active (P in kW) and (Q in kV), and integrate over a time interval to determine the corresponding energies (kVAh, kWh kvarh). Calculations are for each phase and for the total.

Time-stamped histories

Micrologic trip units store information on events (e.g. alarms and their cause) that are time-stamped to within a millisecond.

Protection.....

Ground-fault protection G (Ig)	Protection function specific to electronic circuit breakers, symbolised by G (Ground). This protection can calculate high-threshold residual earth-leakage currents (in the order of tens of Amperes) on the basis of phase-current measurements. Micrologic 5/6 offers this protection function with adjustable pick-up Ig and time delay.
Instantaneous protection I (Ii)	This protection supplements Isd. It provokes instantaneous opening of the device. The pick-up may be adjustable or fixed (built-in). This value is always lower than the contact-repulsion level.
Long-time protection L (Ir)	Protection function where the adjustable Ir pick-up determines a protection curve similar to the thermal-protection curve (inverse-time curve I ² t). The curve is generally determined on the basis of the Ir setting which corresponds to a theoretically infinite tripping time (asymptote) and of the point at 6 Ir at which the tripping time depends on the rating.
Magnetic protection (Im)	Short-circuit protection provided by magnetic trip units (see this term). The pick-up setting may be fixed or adjustable.
Neutral protection (IN)	The neutral is protected because all circuit-breaker poles are interrupted. The setting may be that used for the phases or specific to the neutral, i.e. reduced neutral (0.5 times the phase current) or OSN (oversized neutral) at 1.6 times the phase current. For OSN protection, the maximum device setting is limited to 0.63 In.
Residual-current earth-leakage protection (IΔn)	Protection provided by Vigi modules, in which the residual-current toroids directly detect low-threshold earth-leakage currents (in the order of tens of mA) caused by insulation faults.
Short-delay protection S (Isd)	Protection function specific to electronic circuit breakers, symbolised by S (Short delay or short time). This protection supplements thermal protection. The reaction time is very short, but has a slight time delay to enable discrimination with the upstream device. The short-delay pick-up Isd is adjustable from approximately 1.5 to 10 Ir.
Short-delay protection with fixed time delay So (Isd)	Short-delay protection, but with a fixed time delay. This function is available on Micrologic 2. It is symbolised by So. It ensures discrimination with downstream devices.
Thermal protection (Ir)	Overload protection provided by thermal trip units (see this term) using an inverse-time curve (I ² t).

Relays and auxiliary contacts.....

Auxiliary contact IEC 60947-1	"Contact included in an auxiliary circuit and mechanically operated by the switching device".
Break contact IEC 60947-1	"Control or auxiliary contact which is open when the main contacts of the mechanical switching device are closed and closed when they are open".
Make contact IEC 60947-1	"Control or auxiliary contact which is closed when the main contacts of the mechanical switching device are closed and open when they are open".
Relay (electrical) IEC 60947-1	"Device designed to produce sudden, predetermined changes in one or more electrical output circuits when certain conditions are fulfilled in the electrical input circuits controlling the device".
Relay module with static output	Output of a relay made up of a thyristor or triac electronic component. The low interrupting capacity means that a power relay is required. This is the case for the SDx outputs.

Switchgear.....

Circuit breaker IEC 60947-2	"Mechanical switching device, capable of making, carrying and breaking currents under normal circuit conditions and also making, carrying for a specified time and breaking currents under specified abnormal circuit conditions such as those of short circuit". Circuit breakers are the device of choice for protection against overloads and short-circuits. Circuit breakers may, as is the case for Powerpact, be suitable for isolation.
---------------------------------------	---



Circuit-breaker utilisation category
IEC 60947-2

The standard defines two utilisation categories, A and B, depending on breaker discrimination with upstream breakers under short-circuit conditions.

- Category A. Circuit breakers not specifically designed for discrimination applications.
- Category B. Circuit breakers specifically designed for discrimination, which requires a short time-delay (which may be adjustable) and a rated short-time withstand current in compliance with the standard.

Powerpact 150 to 600 circuit breakers are category A, however, by design, they provide discrimination with downstream devices (see the Complementary technical information guide).

Contactors
IEC 60947-1



"Mechanical switching device having only one position of rest, operated otherwise than by hand, capable of making, carrying and breaking currents under normal circuit conditions including operating overload conditions". A contactor is provided for frequent opening and closing of circuits under load or slight overload conditions. It must be combined and coordinated with a protective device against overloads and short-circuits, such as a circuit breaker.

Contactors utilisation categories
IEC 60947-4-1

The standard defines four utilisation categories, AC1, AC2, AC3 and AC4 depending on the load and the control functions provided by the contactor. The class depends on the current, voltage and power factor, as well as contactor withstand capacity in terms of frequency of operation and endurance.

Current-limiting circuit breaker
IEC 60947-2

"A circuit-breaker with a break-time short enough to prevent the short-circuit current reaching its otherwise attainable peak value".

Disconnectors
IEC 60947-3

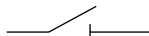

"Mechanical switching device which, in the open position, complies with the requirements specified for the isolating function". A disconnector serves to isolate upstream and downstream circuits. It is used to open or close circuits under no-load conditions or with a negligible current level. It can carry the rated circuit current and, for a specified time, the short-circuit current.

Three-phase asynchronous motors and their protection.....

Locked-rotor protection (Ijam)

This function steps in when the motor shaft cannot or can no longer drive the load. The result is a high overcurrent.

Long-start protection (Ilong)

An overly long start means the current drawn remains too high or too low for too long, with respect to the starting current. In all cases, the load cannot be driven and the start must be interrupted. The resulting temperature rise must be taken into account before restarting.

Phase-unbalance or phase- loss protection (Iunbal)

This protection function steps in if the current values and/or the unbalance in the three phases supplying the motor exceeds tolerances. Currents should be equal and displacement should be one third of a period. Phase loss is a special case of phase unbalance.

Starting current

Start-up of a three-phase, asynchronous motor is characterised by:

- a high inrush current, approximately $14 I_n$ for 10 to 15 ms
- a starting current, approximately $7.2 I_n$ for 5 to 30 seconds
- return to the rated current after the starting time.

Starting time

Time after which the motor ceases to draw the starting current and falls back to the operating current I_r ($\leq I_n$).

Thermal image of the rotor and stator

The thermal image models the thermal behaviour of a motor rotor and stator, taking into account temperature rise caused by overloads or successive starts, and the cooling constants. For each motor power rating, the algorithm takes into account a theoretical amount of iron and copper which modifies the cooling constants.

Thermal protection

Protection against overcurrents following an inverse time curve $I^2t = \text{constant}$, which defines the maximum permissible temperature rise for the motor. Tripping occurs after a time delay that decreases with increasing current.

Trip class
IEC 60947-4-1

The trip class determines the trip curve of the thermal protection device for a motor feeder. The standard defines trip classes 5, 10, 20 and 30. These classes are the maximum durations, in seconds, for motor starting with a starting current of $7.2 I_r$, where I_r is the thermal setting indicated on the motor rating plate.

Under-load protection (lund)

This function steps in when the driven load is too low. It detects a set minimum phase current which signals incorrect operation of the driven machine. In the example of a pump, under-load protection detects when the pump is no longer primed.

Trip units**Electronic trip unit (Micrologic)**

Trip unit that continuously measures the current flowing through each phase and the neutral if it exists. For Micrologic, the measurements are provided by built-in current sensors linked to an analog-digital converter with a high sampling frequency. The measurement values are continuously compared by the ASIC to the protection settings. If a setting is overrun, a Mitop release trips the circuit-breaker operating mechanism.

This type of trip unit offers much better pick-up and delay setting accuracy than thermal-magnetic trip units. It also provides a wider range of protection functions.

Magnetic release

Release actuated by a coil or a lever. A major increase in the current (e.g. a short-circuit) produces in the coil or the lever a change in the magnetic field that moves a core. This trips the circuit breaker operating mechanism. Action is instantaneous. The pick-up setting may be adjustable.

Reflex tripping

Powerpact circuit breakers have a patented reflex-tripping system based on the energy of the arc and that is independent of the other protection functions. It operates extremely fast, before the other protection functions. It is an additional safety function that operates before the others in the event of a very high short-circuit.

Release

IEC 60947-1

Device, mechanically connected to a mechanical switching device (e.g. a circuit breaker), which releases the holding means and permits the opening or the closing of the switching device. For circuit breakers, releases are often integrated in a trip unit.

Shunt release (MX)

This type of release operates when supplied with current. The MX release provokes circuit-breaker opening when it receives a pulse-type or maintained command.

Thermal-magnetic trip unit

Trip unit combining thermal protection for overloads and magnetic protection.

Thermal release

Release in which a bimetal strip is heated by the Joule effect. Above a temperature-rise threshold that is a function of the current and its duration (I^2t curve = constant, which is representative of temperature rise in cables), the bimetal strip bends and releases the circuit-breaker opening mechanism. The pick-up setting may be adjustable.

Undervoltage release (MN)

This type of release operates when the supply voltage drops below the set minimum.

Notes

Notes

Schneider Electric Industries SAS

35, rue Joseph Monier
CS 30323
92506 Rueil Malmaison Cedex
France

RCS Nanterre 954 503 439
Capital social 896 313 776 €
www.schneider-electric.com

As standards, specifications and designs change from time to time, please ask for confirmation of the information given in this publication.

Publication: Schneider Electric Industries SAS
Photos: Schneider Electric
Publishing:



This document has been printed on ecological paper.