

Altivar Process ATV600

Variable Speed Drives for Asynchronous and Synchronous Motors

Programming Manual

EAV64318.10
07/2022



Legal Information

The Schneider Electric brand and any trademarks of Schneider Electric SE and its subsidiaries referred to in this guide are the property of Schneider Electric SE or its subsidiaries. All other brands may be trademarks of their respective owners.

This guide and its content are protected under applicable copyright laws and furnished for informational use only. No part of this guide may be reproduced or transmitted in any form or by any means (electronic, mechanical, photocopying, recording, or otherwise), for any purpose, without the prior written permission of Schneider Electric.

Schneider Electric does not grant any right or license for commercial use of the guide or its content, except for a non-exclusive and personal license to consult it on an "as is" basis. Schneider Electric products and equipment should be installed, operated, serviced, and maintained only by qualified personnel.

As standards, specifications, and designs change from time to time, information contained in this guide may be subject to change without notice.

To the extent permitted by applicable law, no responsibility or liability is assumed by Schneider Electric and its subsidiaries for any errors or omissions in the informational content of this material or consequences arising out of or resulting from the use of the information contained herein.

As part of a group of responsible, inclusive companies, we are updating our communications that contain non-inclusive terminology. Until we complete this process, however, our content may still contain standardized industry terms that may be deemed inappropriate by our customers.

Table of Contents

Safety Information	9
About the Book.....	15
Introduction	19
Setup.....	20
Initial Steps	21
Steps for Setting-Up the Drive.....	23
Software Enhancements	25
Overview	29
Factory Configuration.....	30
Application Functions	31
Basic Functions	34
Graphic Display Terminal	35
Multipoint Screen.....	40
Structure of the Parameter Table.....	42
Finding a Parameter in This Document.....	43
Cyber Security.....	44
Overview.....	44
Password.....	50
Upgrades Management.....	51
Programming	52
[Simply start] 5 5 5 -	53
[Simply start] 5 , 0 - Menu	54
[My menu] 0 5 0 0 - Menu	56
[Modified parameters] L 0 0 - Menu	56
[Dashboard] 0 5 0 -	57
[Pump dashboard] 0 0 0 - Menu	58
[Fan dashboard] 0 0 0 - Menu	61
[Dashboard] 0 5 0 - Menu	63
[Control] 0 0 0 - Menu	64
[Control] 0 0 0 - Menu	68
[Dashboard] 0 5 0 - Menu	69
[kWh Counters] 0 0 0 - menu	70
[Dashboard] 0 5 0 - Menu	72
[Diagnostics] 0 , 0 -	73
[Diag. data]	74
[Error history] 0 0 0 - Menu	76
[Error history] 0 0 0 - Menu	76
[Warnings] 0 0 0 - Menu	78
[Display] 0 0 0 -	80
[Energy parameters]	81
[Elec Ener Input Counter] 0 0 0 , - Menu	81
[Elec Ener Output Counter] 0 0 0 - Menu	83
[Mechanical energy] 0 0 0 - Menu	86
[Energy saving] 0 5 0 - Menu	88
[Application parameters]	90
[Pump parameters]	95
[Variable speed pump] 0 0 0 - Menu	95
[Multipump system] 0 0 0 - Menu	99

[Installation] <i>Π P V S</i> - Menu.....	105
[Motor parameters]	107
[Drive parameters]	110
[Thermal monitoring]	114
[PID display]	115
[Counter management]	117
[Other state]	120
[Other state] <i>S S t</i> - Menu.....	120
[I/O map]	121
[Communication map]	124
[Communication map] <i>C Π Π</i> - Menu	124
[Data logging]	129
[Complete settings] <i>C S t</i> -	133
Overview.....	135
[Macro configuration]	138
[Motor parameters] <i>Π P R</i> - Menu.....	140
[Motor parameters] <i>Π P R</i> - Menu	140
[Data] <i>Π t d</i> - Menu	144
[Motor tune] <i>Π t u</i> - Menu	156
[Motor monitoring] <i>Π o P</i> - Menu.....	164
[Thermal monitoring] <i>t P P</i> - Menu	165
[Motor monitoring] <i>Π o P</i> - Menu.....	174
[Motor control] <i>d r C</i> - Menu.....	177
[Spd Loop Optimization] <i>Π C L</i> - Menu	181
[Motor control] <i>d r C</i> - Menu.....	189
[Switching frequency] <i>S W F</i> - Menu.....	191
[Input Filter] <i>d C r</i> - Menu	194
[Define system units]	195
[Sensors assignment].....	200
[Command and Reference] <i>C r P</i> - Menu	228
[Pump functions] - [Booster control].....	244
[System Architecture] <i>Π P q</i> - Menu	244
[MultiDrive Config] <i>Π P V C</i> - Menu.....	257
[Pumps configuration] <i>P u Π P</i> - Menu	261
[System Architecture] <i>Π P q</i> - Menu	264
[Booster control] <i>b S C</i> - Menu.....	266
[Stage/Destage condition] <i>S d C Π</i> - Menu	270
[Stage/Destage method] <i>S d Π Π</i> - Menu	275
[Booster control] <i>b S C</i> - Menu.....	279
[Pump functions] - [Level control].....	281
[System architecture] <i>Π P q</i> - Menu.....	281
[Pumps configuration] <i>P u Π P</i> - Menu	282
[Level control] <i>L c c</i> - Menu.....	283
[Level control] <i>L c c</i> - Menu.....	291
[Level settings] <i>L c L</i> - Menu	300
[Pump functions] - [PID controller].....	306
[Pump functions] - [Sleep/wakeup]	327
[Sleep/Wakeup] <i>S P W</i> - Overview	327
[Sleep menu] <i>S L P</i> - Menu.....	331
[Sleep menu] <i>S L P</i> - Menu.....	333
[Sleep menu] <i>S L P</i> - Menu.....	334

[Boost] <i>S b L</i> - Menu.....	336
[Advanced sleep check] <i>R d 5</i> - Menu.....	337
[Wake up menu] <i>w k P</i> - Menu	340
[Wake up menu] <i>w k P</i> - Menu	342
[Pump functions] - [Feedback monitoring].....	343
[Pump functions] - [Pump characteristics].....	345
[Pump functions] - [Sensorless flow estimation]	353
[Pump functions] - [dP/Head Correction]	356
[Pump functions] - [Pump start stop]	358
[Pump functions] - [Pipe fill].....	363
[Pump functions] - [Friction loss compensation]	368
[Pump functions] - [Jockey pump]	372
[Pump functions] - [Priming pump ctrl]	375
[Pump functions] - [Flow limitation]	379
[Pump functions] - [Vortex Control]	382
[Pump monitoring] - [Pumpcycle monitoring]	389
[Pump monitoring] - [Anti jam].....	392
[Pump monitoring] - [Dry run Monit]	399
[Pump monitoring] - [Pump low flow Monit]	403
[Pump monitoring] - [Thermal monitoring].....	409
[Pump monitoring] - [Inlet pressure monitoring].....	410
[Pump monitoring] - [Outlet pressure monitoring]	415
[Pump monitoring] - [High flow monitoring].....	420
[Fan] - [PID controller].....	423
[Fan] - [Feedback monitoring].....	423
[Fan] - [Jump frequency].....	424
[Fan]	426
[Generic functions] - [Speed limits].....	429
[Generic functions] - [Ramp].....	433
[Generic functions] - [Ramp switching].....	437
[Generic functions] - [Stop configuration].....	439
[Generic functions] - [Auto DC injection]	445
[Generic functions] - [Ref. operations]	448
[Generic functions] - [Preset speeds].....	450
[Generic functions] - [+/- speed].....	453
[Generic functions] - [Jump frequency]	456
[Generic functions] - [PID controller]	456
[Generic functions] - [Feedback mon.]	456
[Generic functions] - [Threshold reached]	457
[Generic functions] - [Mains contactor command]	459
[Generic functions] - [Output contactor cmd]	462
[Generic functions] - [Reverse disable].....	466
[Generic functions] - [Torque limitation]	467
[Generic functions] - [Parameters switching].....	469
[Generic functions] - [Stop after speed timeout]	476
[Generic functions] - [Active Front End].....	478
[Generic monitoring].....	479
[Process underload] <i>u L d</i> - Menu	479
[Process overload] <i>o L d</i> - Menu.....	482
[Stall monitoring] <i>S t P r</i> - Menu.....	484
[Thermal monitoring] <i>t P P</i> - Menu	486

[Input/Output] - [I/O assignment]	487
[DI1 assignment] L 1 R - to [DI6 assignment] L 6 R - Menus	487
[DI11 assignment] L 11 R - to [DI16 assignment] L 16 R - Menus	488
[DI5 Pulse Input Assign] P , 5 R - Menu	489
[DI6 Pulse Input Assign] P , 6 R - Menu	489
[AI1 assignment] R , 1 R - to [AI5 assignment] R , 5 R - Menus	490
[AIV1 assignment] R V 1 R - to [AIV3 assignment] R V 3 R - Menus	490
[DI50 Assignment] d 5 0 R - to [DI59 Assignment] d 5 9 R - Menus	491
[Input/Output] - [DI/DQ]	492
[DI1 Configuration] d , 1 - to [DI6 Configuration] d , 6 - Menus	492
[DI11 Configuration] d , 11 - to [DI16 Configuration] Menus	493
[DI5 Pulse Config] P R , 5 - Menu	494
[DI6 Pulse Config] P R , 6 - Menu	495
[DQxx Configuration] d o X X - Menu	496
[DI50 Configuration] d , 5 0 - to [DI59 Configuration] d , 5 9 - Menus	500
[Input/Output] - [Analog I/O]	501
[AI1 configuration] R , 1 - Menu	501
[AI2 configuration] R , 2 - Menu	504
[AI3 configuration] R , 3 - Menu	506
[AI4 configuration] R , 4 - Menu	508
[AI5 configuration] R , 5 - Menu	510
[AQ1 configuration] R o 1 - Menu	512
[AQ2 configuration] R o 2 - Menu	517
[Virtual AI1] R V 1 - Menu to [Virtual AI3] R V 3 - Menus	518
[Input/Output] - [Relay]	520
[Relay] r E L R - Menu	520
[Input/Output] , o - Menu	527
[Error/Warning handling]	529
[Auto fault reset] R E r - Menu	529
[Fault reset] r 5 t - Menu	531
[Catch on the fly] F L r - Menu	534
[Error detect disabling] , n H - Menu	536
[External error] E t F - Menu	539
[External error] — [Monitoring circuit A] C n C R - to [Monitoring circuit D] C n C d - Menus	541
[Output phase loss] o P L - Menu	544
[Input phase loss] , P L - Menu	545
[4-20mA loss] L F L - Menu	546
[Fallback speed] L F F - Menu	548
[Spd Maint Behavior] r L 5 - Menu	549
[Fieldbus monitoring] C L L - Menu	550
[Embedded Modbus TCP] E n t C - Menu	552

[Communication module] <i>C o P o</i> - Menu	554
[Undervoltage handling] <i>u S b</i> - Menu	557
[Ground Fault] <i>G r F L</i> - Menu	560
[Motor thermal monit] <i>t H t</i> - Menu	561
[Drive overload monit] <i>o b r</i> - Menu	563
[Warn grp 1 definition] <i>R I C</i> - to [Warn grp 5 definition]	
<i>R S C</i> - Menus.....	564
[Error/Warning Handling] <i>C S W P</i> - menu.....	565
[ON lock settings] <i>L K o n</i> - Menu	566
[Maintenance]	569
[Diagnostics] <i>d R u</i> - Menu	569
[Drive warranty mgnt] <i>d W P R</i> - Menu	570
[Customer event 1] <i>C E 1</i> - Menu.....	571
[Customer event 2] <i>C E 2</i> - to [Customer event 5] <i>C E 5</i> -	
Menus.....	572
[Customer events] <i>C u E V</i> - Menu	573
[Fan management] <i>F A P R</i> - Menu	574
[Maintenance] <i>C S P R</i> - Menu	575
[Cabinet I/O Function] <i>C A B F</i> -	576
Communication	588
[Communication] <i>C o P</i> -	588
[File management] <i>F P t</i> -	590
[Transfer config file] <i>t C F</i> - Menu	591
[Factory settings] <i>F C S</i> - Menu	592
[Parameter group list] <i>F r Y</i> - Menu.....	593
[Factory settings] <i>F C S</i> - Menu	594
[Pre-settings] <i>P r E S</i> - Menu.....	595
[Firmware update] <i>F W u P</i> - Menu	596
[My preferences] <i>P Y P</i> -	597
[Language].....	597
[Password].....	598
[Parameter access]	600
[Customization]	602
[My menu config.] <i>P Y C</i> - Menu	602
[Display screen type] <i>P S C</i> - Menu	603
[Param. Bar Select] <i>P b S</i> - Menu	603
[Customer parameters] <i>C Y P</i> - Menu.....	604
[Service message] <i>S E r</i> - Menu	604
[Date & Time settings].....	605
[Date/time settings] <i>r t C</i> - Menu.....	605
[Access level] <i>L R C</i> - Menu	606
[Webserver]	607
[Functions key mgnt]	609
[LCD settings].....	610
[Stop and go]	611
[QR code].....	615
[Pairing password].....	616
Maintenance	617
Diagnostics and Troubleshooting.....	619
Warning Codes.....	620
Error Codes	623

[Adv. Function Lock] <i>A F L F</i>	628
[VxCtrl Error] <i>V c F</i>	698
FAQ	699
Glossary	701

Safety Information

Important Information

Read these instructions carefully, and look at the equipment to become familiar with the device before trying to install, operate, service, or maintain it. The following special messages may appear throughout this documentation or on the equipment to warn of potential hazards or to call attention to information that clarifies or simplifies a procedure.



The addition of this symbol to a “Danger” or “Warning” safety label indicates that an electrical hazard exists which will result in personal injury if the instructions are not followed.



This is the safety alert symbol. It is used to alert you to potential personal injury hazards. Obey all safety messages that follow this symbol to avoid possible injury or death.

DANGER

DANGER indicates a hazardous situation which, if not avoided, **will result in** death or serious injury.

WARNING

WARNING indicates a hazardous situation which, if not avoided, **could result in** death or serious injury.

CAUTION

CAUTION indicates a hazardous situation which, if not avoided, **could result in** minor or moderate injury.

NOTICE

NOTICE is used to address practices not related to physical injury.

Please Note

Electrical equipment should be installed, operated, serviced, and maintained only by qualified personnel. No responsibility is assumed by Schneider Electric for any consequences arising out of the use of this material.

A qualified person is one who has skills and knowledge related to the construction and operation of electrical equipment and its installation, and has received safety training to recognize and avoid the hazards involved.

Qualification Of Personnel

Only appropriately trained persons who are familiar with and understand the contents of this manual and all other pertinent product documentation are authorized to work on and with this product. In addition, these persons must have received safety training to recognize and avoid hazards involved. These persons must have sufficient technical training, knowledge and experience and be able to foresee and detect potential hazards that may be caused by using the product, by changing the settings and by the mechanical, electrical and electronic equipment of the entire system in which the product is used. All persons working on and with

the product must be fully familiar with all applicable standards, directives, and accident prevention regulations when performing such work.

Intended Use

This product is a drive for three-phase synchronous, asynchronous motors and intended for industrial use according to this manual.

The product may only be used in compliance with all applicable safety standard and local regulations and directives, the specified requirements and the technical data. The product must be installed outside the hazardous ATEX zone. Prior to using the product, you must perform a risk assessment in view of the planned application. Based on the results, the appropriate safety measures must be implemented. Since the product is used as a component in an entire system, you must ensure the safety of persons by means of the design of this entire system (for example, machine design). Any use other than the use explicitly permitted is prohibited and can result in hazards.

Product Related Information

Read and understand these instructions before performing any procedure with this drive.

DANGER

HAZARD OF ELECTRIC SHOCK, EXPLOSION OR ARC FLASH

- Only appropriately trained persons who are familiar with and fully understand the contents of the present manual and all other pertinent product documentation and who have received all necessary training to recognize and avoid hazards involved are authorized to work on and with this drive system.
- Installation, adjustment, repair and maintenance must be performed by qualified personnel.
- Verify compliance with all local and national electrical code requirements as well as all other applicable regulations with respect to grounding of all equipment.
- Only use properly rated, electrically insulated tools and measuring equipment.
- Do not touch unshielded components or terminals with voltage present.
- Prior to performing any type of work on the drive system, block the motor shaft to prevent rotation.
- Insulate both ends of unused conductors of the motor cable.
- Do not short across the DC bus terminals or the DC bus capacitors or the braking resistor terminals.

Failure to follow these instructions will result in death or serious injury.

⚠️⚠️ DANGER**HAZARD OF ELECTRIC SHOCK, EXPLOSION, OR ARC FLASH**

Before performing work on the drive system:

- Disconnect all power, including external control power that may be present. Take into account that the circuit breaker or main switch does not de-energize all circuits.
- Place a “Do Not Turn On” label on all power switches related to the drive system.
- Lock all power switches in the open position.
- Wait 15 minutes to allow the DC bus capacitors to discharge.
- Verify the absence of voltage. (1)

Before applying voltage to the drive system:

- Verify that the work has been completed and that the entire installation cannot cause hazards.
- If the mains input terminals and the motor output terminals have been grounded and short-circuited, remove the ground and the short circuits on the mains input terminals and the motor output terminals.
- Verify proper grounding of all equipment.
- Verify that all protective equipment such as covers, doors, grids is installed and/or closed.

Failure to follow these instructions will result in death or serious injury.

Refer to Verifying the absence of voltage to the installation manual of the product.

Damaged products or accessories may cause electric shock or unanticipated equipment operation.

⚠️⚠️ DANGER**ELECTRIC SHOCK OR UNANTICIPATED EQUIPMENT OPERATION**

Do not use damaged products or accessories.

Failure to follow these instructions will result in death or serious injury.

Contact your local Schneider Electric sales office if you detect any damage whatsoever.

This equipment has been designed to operate outside of any hazardous location. Only install this equipment in zones known to be free of a hazardous atmosphere.

⚠️ DANGER**POTENTIAL FOR EXPLOSION**

Install and use this equipment in non-hazardous locations only.

Failure to follow these instructions will result in death or serious injury.

Your application consists of a whole range of different interrelated mechanical, electrical, and electronic components, the drive being just one part of the application. The drive by itself is neither intended to nor capable of providing the entire functionality to meet all safety-related requirements that apply to your application. Depending on the application and the corresponding risk assessment to be conducted by you, a whole variety of additional equipment is required such as, but not limited to, external encoders, external brakes, external monitoring devices, guards, etc.

As a designer/manufacture of machines, you must be familiar with and observe all standards that apply to your machine. You must conduct a risk assessment and determine the appropriate Performance Level (PL) and/or Safety Integrity Level (SIL) and design and build your machine in compliance with all applicable standards. In doing so, you must consider the interrelation of all components of the machine. In addition, you must provide instructions for use that enable the user of your machine to perform any type of work on and with the machine such as operation and maintenance in a safe manner.

The present document assumes that you are fully aware of all normative standards and requirements that apply to your application. Since the drive cannot provide all safety-related functionality for your entire application, you must ensure that the required Performance Level and/or Safety Integrity Level is reached by installing all necessary additional equipment.

⚠ WARNING

INSUFFICIENT PERFORMANCE LEVEL/SAFETY INTEGRITY LEVEL AND/OR UNINTENDED EQUIPMENT OPERATION

- Conduct a risk assessment according to EN ISO 12100 and all other standards that apply to your application.
- Use redundant components and/or control paths for all critical control functions identified in your risk assessment.
- Implement all monitoring functions required to avoid any type of hazard identified in your risk assessment, for example, slipping or falling loads.
- Verify that the service life of all individual components used in your application is sufficient for the intended service life of your overall application.
- Perform extensive commissioning tests for all potential error situations to verify the effectiveness of the safety-related functions and monitoring functions implemented, for example, but not limited to, speed monitoring by means of encoders, short circuit monitoring for all connected equipment, correct operation of brakes and guards.
- Perform extensive commissioning tests for all potential error situations to verify that the load can be brought to a safe stop under all conditions.

Failure to follow these instructions can result in death, serious injury, or equipment damage.

The products may perform unexpected movements because of incorrect wiring, incorrect settings, incorrect data or other errors.

⚠ WARNING

UNANTICIPATED EQUIPMENT OPERATION

- Carefully install the wiring in accordance with the EMC requirements.
- Do not operate the product with unknown or unsuitable settings or data.
- Perform a comprehensive commissioning test.

Failure to follow these instructions can result in death, serious injury, or equipment damage.

▲ WARNING**LOSS OF CONTROL**

- The designer of any control scheme must consider the potential failure modes of control paths and, for critical control functions, provide a means to achieve a safe state during and after a path failure. Examples of critical control functions are emergency stop, overtravel stop, power outage and restart.
- Separate or redundant control paths must be provided for critical control functions.
- System control paths may include communication links. Consideration must be given to the implications of unanticipated transmission delays or failures of the link.
- Observe all accident prevention regulations and local safety guidelines (1).
- Each implementation of the product must be individually and thoroughly tested for proper operation before being placed into service.

Failure to follow these instructions can result in death, serious injury, or equipment damage.

(1) For USA: Additional information, refer to NEMA ICS 1.1 (latest edition), Safety Guidelines for the Application, Installation, and Maintenance of Solid State Control and to NEMA ICS 7.1 (latest edition), Safety Standards for Construction and Guide for Selection, Installation and Operation of Adjustable-Speed Drive Systems.

The temperature of the products described in this manual may exceed 80 °C (176 °F) during operation.

▲ WARNING**HOT SURFACES**

- Ensure that any contact with hot surfaces is avoided.
- Do not allow flammable or heat-sensitive parts in the immediate vicinity of hot surfaces.
- Verify that the product has sufficiently cooled down before handling it.
- Verify that the heat dissipation is sufficient by performing a test run under maximum load conditions.

Failure to follow these instructions can result in death, serious injury, or equipment damage.

Machines, controllers, and related equipment are usually integrated into networks. Unauthorized persons and malware may gain access to the machine as well as to other devices on the network/fieldbus of the machine and connected networks via insufficiently secure access to software and networks.

▲ WARNING

UNAUTHORIZED ACCESS TO THE MACHINE VIA SOFTWARE AND NETWORKS

- In your hazard and risk analysis, consider all hazards that result from access to and operation on the network/fieldbus and develop an appropriate cyber security concept.
- Verify that the hardware infrastructure and the software infrastructure into which the machine is integrated as well as all organizational measures and rules covering access to this infrastructure consider the results of the hazard and risk analysis and are implemented according to best practices and standards covering IT security and cyber security (such as: ISO/IEC 27000 series, Common Criteria for Information Technology Security Evaluation, ISO/IEC 15408, IEC 62351, ISA/IEC 62443, NIST Cybersecurity Framework, Information Security Forum - Standard of Good Practice for Information Security, SE recommended Cybersecurity Best Practices*).
- Verify the effectiveness of your IT security and cyber security systems using appropriate, proven methods.

Failure to follow these instructions can result in death, serious injury, or equipment damage.

(*) : SE Recommended Cybersecurity Best Practices can be downloaded on SE.com.

▲ WARNING

LOSS OF CONTROL

Perform a comprehensive commissioning test to verify that communication monitoring properly detects communication interruptions

Failure to follow these instructions can result in death, serious injury, or equipment damage.

NOTICE

DESTRUCTION DUE TO INCORRECT MAINS VOLTAGE

Before switching on and configuring the product, verify that it is approved for the mains voltage.

Failure to follow these instructions can result in equipment damage.

About the Book

Document Scope

The purpose of this document is to:

- help you to set up the drive,
- show you how to program the drive,
- show you the different menus, modes, and parameters,
- help you in maintenance and diagnostics.

Validity Note

Original instructions and information given in this manual have been written in English (before optional translation).

This documentation is valid for Altivar Process ATV600 drives (ATV630, ATV650, ATV660, ATV680, ATV6A0, ATV6B0, ATV6L0).

The technical characteristics of the devices described in the present document also appear online. To access the information online, go to the Schneider Electric home page www.se.com/ww/en/download/.

The characteristics that are described in the present document should be the same as those characteristics that appear online. In line with our policy of constant improvement, we may revise content over time to improve clarity and accuracy. If you see a difference between the document and online information, use the online information as your reference.

Related Documents

Use your tablet or your PC to quickly access detailed and comprehensive information on all our products on www.se.com.

The internet site provides the information you need for products and solutions:

- The whole catalog for detailed characteristics and selection guides,
- The CAD files to help design your installation, available in over 20 different file formats,
- All software and firmware to maintain your installation up to date,
- A large quantity of White Papers, Environment documents, Application solutions, Specifications... to gain a better understanding of our electrical systems and equipment or automation,
- And finally all the User Guides related to your drive, listed below:

Title of Documentation	Catalog Number
Digital Catalog for Industrial Automation	Digit-Cat
Catalog: Altivar Process ATV600 variable speed drives	DIA2ED2140502EN (English), DIA2ED2140502FR (French)
ATV600 Getting Started	EAV63253 (English), EAV63254 (French), EAV63255 (German), EAV63256 (Spanish), EAV63257 (Italian), EAV64298 (Chinese), EAV63253PT (Portuguese), EAV63253TR (Turkish)
ATV600 Getting Started Annex (SCCR)	EAV64300 (English)
ATV630, ATV650 Installation Manual	EAV64301 (English), EAV64302 (French), EAV64306 (German), EAV64307 (Spanish), EAV64310 (Italian), EAV64317 (Chinese), EAV64301PT (Portuguese), EAV64301TR (Turkish)
ATV600 Programming Manual	EAV64318 (English), EAV64320 (French), EAV64321 (German), EAV64322 (Spanish), EAV64323 (Italian), EAV64324 (Chinese), EAV64318PT (Portuguese), EAV64318TR (Turkish)

Title of Documentation	Catalog Number
ATV600 Modbus Serial Link Manual (Embedded)	EAV64325 (English)
ATV600 Ethernet Manual (Embedded)	EAV64327 (English)
ATV600 Ethernet IP - Modbus TCP Manual (VW3A3720, 721)	EAV64328 (English)
ATV600 BACnet MS/TP Manual (VW3A3725)	QGH66984 (English)
ATV600 PROFIBUS DP manual (VW3A3607)	EAV64329 (English)
ATV600 DeviceNet manual (VW3A3609)	EAV64330 (English)
ATV600 PROFINET manual (VW3A3627)	EAV64331 (English)
ATV600 CANopen Manual (VW3A3608, 618, 628)	EAV64333 (English)
ATV600 POWERLINK manual (VW3A3619)	PHA99690 (English)
ATV600 Communication Parameters	EAV64332 (English)
ATV600 Embedded Safety Function manual	EAV64334 (English)
Altivar Process Drive Systems Installation manual (ATV660, ATV680, ATV960, ATV980)	NHA37119 (English), NHA37121 (French), NHA37118 (German), NHA37122 (Spanish), NHA37123 (Italian), NHA37130 (Chinese), NHA37124 (Dutch), NHA37126 (Polish), NHA37127 (Portuguese), NHA37129 (Turkish)
ATV660 Handbook	NHA37111 (English), NHA37110 (German)
ATV680 Handbook	NHA37113 (English), NHA37112 (German)
ATV600F, ATV900F Installation Instruction sheet	NVE57369 (English)
ATV600, ATV900 ATEX manual	NVE42416 (English)
SoMove: FDT	SoMove_FDT (English, French, German, Spanish, Italian, Chinese)
ATV600: DTM	ATV6xx_DTM_Library_EN (English - to be installed first), ATV6xx_DTM_Lang_FR (French), ATV6xx_DTM_Lang_DE (German), ATV6xx_DTM_Lang_SP (Spanish), ATV6xx_DTM_Lang_IT (Italian), ATV6xx_DTM_Lang_CN (Chinese)
ATV61-71 to ATV600-900 Migration Manual	EAV64336 (English)
Application Note: ATV600 Multi-Drives Booster Control Optimized	QGH36060 (English)
Application Note: ATV600 Multi-Masters Booster Control Pressure Feedback with Service Continuity	QGH36061 (English)
Application Note: ATV600 Multi-Drives Standard Level Control	QGH36059 (English)
Application Note: ATV600 Multi-Masters with Optimized Level Control	EAV64367 (English)
Recommended Cybersecurity Best Practices	CS-Best-Practices-2019-340 (English)

You can download these technical publications and other technical information from our website at www.se.com/en/download

Terminology

The technical terms, terminology, and the corresponding descriptions in this manual normally use the terms or definitions in the relevant standards.

In the area of drive systems this includes, but is not limited to, terms such as **error**, **error message**, **failure**, **fault**, **fault reset**, **protection**, **safe state**, **safety function**, **warning**, **warning message**, and so on.

Among others, these standards include:

- IEC 61800 series: Adjustable speed electrical power drive systems
- IEC 61508 Ed.2 series: Functional safety of electrical/electronic/programmable electronic safety-related
- EN 954-1 Safety of machinery - safety-related parts of control systems
- ISO 13849-1 & 2 Safety of machinery - safety related parts of control systems
- IEC 61158 series: Industrial communication networks - Fieldbus specifications
- IEC 61784 series: Industrial communication networks - Profiles
- IEC 60204-1: Safety of machinery - Electrical equipment of machines – Part 1: General requirements

In addition, the term **zone of operation** is used in conjunction with the description of specific hazards, and is defined as it is for a **hazard zone** or **danger zone** in the EC Machinery Directive (2006/42/EC) and in ISO 12100-1.

Contact Us

Select your country on:

www.se.com/contact

Schneider Electric Industries SAS

Head Office

35, rue Joseph Monier

92500 Rueil-Malmaison

France

Introduction

What's in This Part

Setup	20
Overview	29
Cyber Security	44

Setup

What's in This Chapter

Initial Steps	21
Steps for Setting-Up the Drive	23
Software Enhancements	25

Initial Steps

Before Powering up the Drive

▲ WARNING

UNANTICIPATED EQUIPMENT OPERATION

Before switching on the device, verify that no unintended signals can be applied to the digital inputs that could cause unintended movements.

Failure to follow these instructions can result in death, serious injury, or equipment damage.

If the drive was not connected to mains for an extended period of time, the capacitors must be restored to their full performance before the motor is started.

NOTICE

REDUCED CAPACITOR PERFORMANCE

- Apply mains voltage to the drive for one hour before starting the motor if the drive has not been connected to mains for the specified periods of time.(1)
- Verify that no Run command can be applied before the period of one hour has elapsed.
- Verify the date of manufacture if the drive is commissioned for the first time and run the specified procedure if the date of manufacture is more than 12 months in the past.

Failure to follow these instructions can result in equipment damage.

(1) Period of time:

- 12 months at a maximum storage temperature of +50°C (+122°F)
- 24 months at a maximum storage temperature of +45°C (+113°F)
- 36 months at a maximum storage temperature of +40°C (+104°F)

If the specified procedure cannot be performed without a Run command because of internal mains contactor control, perform this procedure with the power stage enabled, but the motor being at a standstill so that there is no appreciable mains current in the capacitors.

Mains Contactor

NOTICE

RISK OF DAMAGE TO THE DRIVE

Do not switch on the drive at intervals of less than 60 s.

Failure to follow these instructions can result in equipment damage.

Using a Motor with a Lower Rating or Dispensing with a Motor Altogether

In factory settings, the motor output phase loss detection is active:

[OutPhaseLoss Assign] \square P L is set to **[OPF Error Triggered] \square E 5**. For details, refer to the parameter description, page 544. For commissioning tests or maintenance phase, the drive could be connected to a small motor power size and thus trigger an error **[Output Phase Loss] \square P F 2** or **[Single output phase**

loss] $\square P F I$ when a Run command is applied. For that purpose, the function can be disabled by setting **[OutPhaseLossAssign]** $\square P L$ to **[Function Inactive]** $n \square$.

Set also **[Motor control type]** $C E E$ to **[U/F VC Standard]** $S E d$ in **[Motor parameters]** $P P R$ - . For details, refer to the parameter description, page 177.

NOTICE

MOTOR OVERHEATING

Install external thermal monitoring equipment under the following conditions:

- If a motor with a nominal current of less than 20% of the nominal current of the drive is connected.
- If you use the function Motor Switching.

Failure to follow these instructions can result in equipment damage.

DANGER

HAZARD OF ELECTRIC SHOCK, EXPLOSION OR ARC FLASH

If output phase monitoring is disabled, phase loss and, by implication, accidental disconnection of cables, are not detected.

- Verify that the setting of this parameter does not result in unsafe conditions.

Failure to follow these instructions will result in death or serious injury.

Steps for Setting-Up the Drive

1 INSTALLATION

Refer to the installation manual.

2 Switch On the drive without active run command.

3 Configure:

- The nominal frequency of the motor **[Motor Standard] b F r** if this is not 50 Hz.
- The motor parameters including **[Motor Th Current] i L H** in the **[Motor parameters] P P R** - menu, only if the factory configuration of the drive is not suitable.
- The application functions in the **[Complete settings] C S E** - menu, only if the factory configuration of the drive is not suitable.



4 In the **[Pump start stop] P S E** - menu, adjust the following parameters:

- [Acceleration] A C C** and **[Deceleration] D E C**
- [Low speed] L S P** and **[High Speed] H S P**

5 Start the drive.

Drive systems may perform unexpected movements because of incorrect wiring, incorrect settings, incorrect data or other errors.

⚠ WARNING

UNANTICIPATED EQUIPMENT OPERATION

- Carefully install the wiring in accordance with the EMC requirements.
- Do not operate the product with unknown or unsuitable settings or data.
- Perform a comprehensive commissioning test.

Failure to follow these instructions can result in death, serious injury, or equipment damage.

Tips

Use the **[Config. Source] F C S** , parameter , page 592 to restore the factory settings at any time.

NOTE: The following operations must be performed for optimum drive performance in terms of accuracy and response time:

- Enter the values indicated on the motor nameplate in the **[Motor parameters]** *Π P R* - menu.
- Perform autotuning with the motor cold and connected using the **[Autotuning]** *Ε υ η* parameter.

Software Enhancements

Overview

Since the Altivar Process was first launched, it has benefited from the addition of several new functions. The software version has been updated to V3.6.

Although this documentation relates to version V3.6, it can still be used with earlier versions.

Enhancements Made to Version V3.6 in Comparison to V3.4

RSTP settings are now accessible via the Graphic Display terminal, a new **[RSTP Configuration]** *r S t P* - menu is available, including its related parameters.

[Ratio d-axis error] *r d R E* is accessible for asynchronous motors to perform adjustments on **[Magnetizing Current]** *i d R* for asynchronous motors.

New possible setting is available for **[Ground Fault Activation]** *G r F L* .

Parameters **[Nom Motor Tq Scaling]** *t q n C* , **[Expert Motor]** *t q n P* and **[Plate Nom Motor Tq]** *t q n o* have been added to define the reference of the nominal motor torque.

In **[Pump functions]** *P F t* section, **[Vortex control]** *V C t L* - menu is now available, including its related parameters.

In the **[Level control]** *L C C* - menu, new parameters **[PI Integ Cst Time]** *L C t* , ... **[Flow Stabilization Thd]** *L C d F* have been added.

New possible setting for the parameter **[Reverse Disable]** *r i n* .

New possible setting **[Optimized]** *o P t* for the parameter **[Sinus Filter Activation]** *o F i* .

In **[Error/Warning handling]** menu, **[Spd Maint Behavior]** *r L S* - menu is available to determine the drive behavior after an AI loss event.

Enhancements Made to Version V3.4 in Comparison to V2.6

Firmware evolution to support Altivar Process Modular Liquid Cooled offer (ATV6L0). New features dedicated to this offer have been added such as **[Mixing Valve]** *M V C o* setting and diagnostics of the cooling pump (**[Pump diagnostics]** *C P t*).

Improvements related to cybersecurity. By default, user authentication is necessary to connect to the drive via PC software tools such as SoMove-DTM (using Modbus TCP communication through Ethernet). **[User authentication]** *S E C E* - menu has been added in **[Embd Eth Config]** *E t E* - menu, **[User authentication]** *S E C o* - menu has been added in **[Eth Module Config]** *E t o* - menu and **[User authentication]** *S E C P* - has been added in **[Profinet]** *P n C* - . For more information refer to DTM online help.

NOTE: To fully support this evolution with Ethernet module (respectively Profinet module), the minimum firmware version of Ethernet module (respectively Profinet module) must be V1.15IE26 (respectively V1.9IE19).

In **[Ramp]** *r R n P* - menu, **[Braking Current Level]** *b d C L* is added to modify the maximum current level for braking deceleration.

Fallback feature is added on drive outputs. When the corresponding output is controlled by fieldbus, the output is reset if an error is triggered.

In the menu **[Fault reset]** *r 5 E* - menu, **[Extended Fault Reset]** *H r F E* parameter is now available.

[Fallback Channel] *R F F L* has been added to handle automatic channel fallback in case of fieldbus communication interruption.

New possible settings are available on drive outputs (digital outputs and relays).

In the **[Error/Warning Handling]** *E 5 W P* - menu, the **[ON lock settings]** *L K o n* - menu is available, including its related parameters.

New possible settings for **[Monitoring circuit A]** *E P C A* - ...**[Monitoring circuit D]** *E P C d* - functions. These menus are also now available in **[External error]** *E E F* - menu.

Enhancements Made to Version V2.6 in Comparison to V2.5

In the tab **[Data]** *P E d* - of the **[Motor Data]** *P o A* - menu, **[Torque Scaling]** *i n r E* parameter is added. It allows to show and modify the scaling of parameters such as **[Nom Motor Torque]** *E 9 5*.

Enhancements Made to Version V2.5 in Comparison to V2.4

Firmware evolution to support Altivar Process Modular 690V Low Harmonic / Regen offer.

In the **[Motor parameters]** *P P A* - menu, the **[Input Filter]** *d E r* - menu is available, including its related parameters.

Enhancements Made to Version V2.4 in Comparison to V2.3

Firmware evolution to support Altivar Process Modular 690V standard offer.

Improvement of the function **[Stop and go]** *S E G* - with a time parameter.

[Output Contactor Cmd] *o C C* - function is now available.

Improvement of the password protection to limit the access to the menus.

Enhancements Made to Version V2.3 in Comparison to V2.2

Reluctance motor control law is added. See in the **[Complete Settings]** *E 5 E* - , **[Motor Parameters]** *P P A* - menu.

According to the selected motor control law, **[Speed loop optimization]** *P C L* - menu is now available.

The virtual analog input type is now settable with **[AIVx type]** *A V X E* parameters.

Support of bidirectional scaled analog inputs, see **[Aix range]** *A i X L* parameters.

[Input phase loss] *P H F* is cleared as soon as its cause has been removed.

Enhancements Made to Version V2.2 in Comparison to V1.9

Firmware evolution to support Altivar Process Modular 400V standard offer.

Support of VW3A3619 POWERLINK fieldbus module.

In the **[Motor control] d r C** - menu, "Output Voltage Management and Overmodulation" function is added.

A new possible behavior is added for the STOP/RESET key, see **[Stop Key Enable] P 5 E** parameter.

Enhancements Made to Version V1.9 in Comparison to V1.8

In the **[Catch on Fly] F L r** - menu, a new selection has been added to allow the function to be active after stop types different than freewheel.

Enhancements Made to Version V1.8 in Comparison to V1.7

Firmware evolution to support ATV•••••S6• and ATV•••••Y6 (600 Vac and 500/690 Vac) catalog numbers.

In the **[Catch on the fly] F L r** - Menu, a new method to estimate the speed has been added. The selection can be done through the parameter **[Catch On Fly Mode] C o F n**. In factory setting, the speed estimation is same as previous software versions.

In the **[Error detect disabling] i n H** - menu, **[Forced Run] i n H S** and **[Forced Run Ref] i n H r** parameter have been added.

Enhancements Made to Version V1.7 in Comparison to V1.6

Support of VW3A3725 BACnet MS/TP fieldbus module.

Enhancements Made to Version V1.6 in Comparison to V1.5

MultiDrive Link feature is available on ATV600 drives using a VW3A3721 EthernetIP/ModbusTCP fieldbus module.

Support of Multi Drives (1 Master drive and up to 5 slaves) and Multi Masters (1 Master only drive and up to 5 Masters or Slaves drives) architectures in **[Booster Control] b 5 E** - and **[Level Control] L V L** - functions.

Improvements and new functionalities on **[Booster Control] b 5 E** - and **[Level Control] L V L** - functions can be found in their related menus.

An output of the drive can be affected to value **[HMI cmd.] b n P**. This output is active when the Local/Remote key of Graphic Display Terminal is pressed and command and reference values comes from Graphic Display Terminal.

Enhancements Made to Version V1.5 in Comparison to V1.4

Support of VW3A3720 EthernetIP/ModbusTCP fieldbus module.

Two virtual analog inputs has been added in **[Input/Output] i o** - , **[Sensor Assignment] S 5 C** - menu.

Enhancements Made to Version V1.4 in Comparison to V1.3

Unification of Altivar Process ATV600 software version for all the product catalogue numbers.

Enhancements Made to Version V1.3 in Comparison to V1.2

In the **[Dashboard]** *d S H* - menu, the content of the tabs is improved for pumps and fan applications.

In the **[Complete settings]** *C S E* - menu, the **[Macro Configuration]** *Π C r* - submenu is added with the **[Application Selection]** *Α P P E* parameter. It allows to hide unnecessary parameters according to the selected application type.

In the **[Pump functions]** *P F E* - menu, **[Booster Control]** *b S E* - and **[Level Control]** *L u L* - functions are available, including their related parameters and the settings for multi-pump architecture.

A new possible setting **[Rotational Current Injection]** *r C i*, is added for synchronous motor **[Angle setting type]** *Α S E*.

Up to 4 QR codes customizable with the commissioning software are displayed in **[QR code]** *q r C* - menu.

Enhancements Made to Version V1.2 in Comparison to V1.1

Factory setting		Enhancements
[Output Short Circuit Test] <i>S E r E</i>		This function is now enabled in factory configuration and is accessible in the [Motor monitoring] <i>Π o P</i> - menu
Menu	Parameter	Enhancements
[Motor parameters] <i>Π P R</i> -	[Motor Control Type] <i>C E E</i>	[SYN_U VC] <i>S Y n u</i> : motor control type specific for permanent magnet synchronous motors
[Sleep/Wakeup] <i>S P W</i> -	[Sleep Detect Mode] <i>S L P Π</i>	Replacement of [Sensor] <i>S n S r</i> : system enters in sleep mode on sensor condition by: <ul style="list-style-type: none"> • [Flow] <i>L F</i>: system enters in sleep mode on low flow • [Pressure] <i>H P</i>: system enters in sleep mode on high pressure • [Multiple] <i>o r</i>: system enters in sleep mode on multiple-OR condition
		Addition of possible pressure sensor assignment and configuration for sleep function: <ul style="list-style-type: none"> • [Aix Sensor config.] <i>S o A X</i> - • [AIV1 Sensor Config.] <i>S o V I</i> - • [Sleep Pressure Level] <i>S L P L</i>
	[Wake Up Mode] <i>w u P Π</i>	Addition of [Pressure] <i>L P</i> : wake up on low-pressure condition
		Addition of possible pressure sensor assignment and configuration for wake-up function: <ul style="list-style-type: none"> • [Aix Sensor config.] <i>w o A X</i> - • [AIV1 Sensor Config.] <i>w o V I</i> - • [Wake Up Press Level] <i>w u P L</i>
[Pipe fill] <i>P F i</i> -	[Pipe Fill on Wake Up] <i>P F W u</i>	New parameter
[Counter Management] <i>E L E</i> -	[Fan operation Time] <i>F c P E</i>	Replacement by [Fan operation Time] <i>F P b E</i> (32 bits)
[Data] <i>Π E d</i> -	[% error EMF sync] <i>r d R E</i>	This parameter is now accessible with the Graphic Display Terminal

Overview

What's in This Chapter

Factory Configuration	30
Application Functions	31
Basic Functions.....	34
Graphic Display Terminal	35
Multipoint Screen	40
Structure of the Parameter Table	42
Finding a Parameter in This Document	43

Factory Configuration

Factory Settings

The drive is factory-set for common operating conditions:

- Display: drive ready **[Pre-Ramp Ref Freq]** F_{rH} when motor is ready to run and motor frequency when motor is running.
- The DI3 and DI5 to DI6 digital inputs, AI2 and AI3 analog inputs, R2 and R3 relays are unassigned.
- Stop mode when error detected: freewheel.

This table presents the basic parameters of the drive and their factory setting values:

Code	Name	Factory setting values
bFr	[Motor Standard]	[50Hz IEC] 50
rIn	[Reverse Disable]	[Yes] YES
tCC	[2/3-Wire Control]	[2-Wire Control] $2C$: 2-wire control
ctt	[Motor control type]	[U/F VC Quad.] $UF9$: U/F for quadratics loads
ACC	[Acceleration]	10.0 s
dEC	[Deceleration]	10.0 s
LSP	[Low Speed]	0.0 Hz
HSP	[High Speed]	50.0 Hz
tEH	[Motor Th Current]	Nominal motor current (value depending on drive rating)
Frd	[Forward]	[DI1] dI : Digital input DI1
Frl	[Ref Freq 1 Config]	[AI1] AI : Analog input AI1
rI	[R1 Assignment]	[Operating State Fault] FLt : the contact opens when the drive has detected error or when the drive has been switched off
brA	[Dec.Ramp Adapt]	[Yes] YES : function active (automatic adaptation of deceleration ramp)
$Retr$	[Auto Fault Reset]	[No] no : function inactive
Stt	[Type of stop]	[On Ramp] rPP : on ramp
$Ra1$	[AQ1 assignment]	[Motor Frequency] oFr : Motor frequency
$Ra2$	[AQ2 assignment]	[Motor Current] oCr : Motor current

NOTE: If you want to restore the drive presettings to their factory values, set **[Config. Source]** $FL5$ to **[Macro Config]** $in1$.

Verify whether the above values are compatible with the application and modify them if required.

Application Functions

Introduction

The following tables show the combinations of functions and applications in order to guide your selection.

The applications in these tables relate to the following applications:

- Borehole pump
- Pumping station
- Boosting station
- Miscellaneous: fan, compressor
- Lift station

Each application has its own special features, and the combinations listed here are not mandatory or exhaustive.

Some functions are designed specifically for a given application. In this case, the application is identified by a tab in the margin on the relevant programming pages.

⚠ WARNING

UNANTICIPATED EQUIPMENT OPERATION

Multiple functions can be assigned to and simultaneously activated via a single input.

- Verify that assigning multiple functions to a single input does not result in unsafe conditions.

Failure to follow these instructions can result in death, serious injury, or equipment damage.

Combinations of Functions and Control Functions

Function	Application				
	Borehole pump	Pumping station	Boosting station	Miscellaneous	Lift station
PID controller , page 306	✓	✓	✓	✓	
Sleep/wake up , page 327			✓		
Feedback monitoring , page 343	✓	✓	✓	✓	✓
Pump characteristics , page 345	✓	✓	✓	✓	✓
Pump start stop , page 358	✓	✓	✓	✓	✓
Pipe fill , page 363			✓	✓	
Friction loss compensation , page 368			✓		
Sensorless flow estimation , page 353	✓	✓		✓	✓
Jockey pump , page 372			✓		
Priming pump control , page 375			✓		
Flow limitation , page 379	✓	✓	✓		
Jump frequency , page 424					
Automatic restart , page 529	✓	✓		✓	✓

Function	Application				
	Borehole pump	Pumping station	Boosting station	Miscellaneous	Lift station
Catch on fly , page 534				✓	
Threshold reached , page 457	✓	✓	✓	✓	✓
Mains contactor command , page 459	✓	✓	✓	✓	✓
Reverse disable , page 466	✓	✓	✓	✓	
Torque limitation , page 467				✓	
Parameter set switching , page 469	✓	✓	✓	✓	✓
Stop on prolonged speed , page 476		✓		✓	
Acceleration deceleration ramps , page 433	✓	✓	✓	✓	✓
Motor control type , page 140	✓	✓	✓	✓	✓
Motor tune , page 140	✓	✓	✓	✓	✓
Output phase rotation , page 178	✓	✓	✓	✓	✓

Combinations of Functions and Monitoring Functions

Function	Application				
	Borehole pump	Pumping station	Boosting station	Miscellaneous	Lift station
Pumpcycle monitoring , page 389	✓	✓	✓	✓	✓
Anti-Jam , page 392		✓			✓
Dry run monitoring , page 399	✓	✓	✓	✓	✓
Pump low flow monitoring , page 403	✓	✓	✓	✓	✓
Thermal pump monitoring , page 165	✓	✓	✓	✓	✓
Inlet pressure monitoring , page 410		✓	✓		
Outlet pressure monitoring , page 415	✓	✓	✓	✓	
High flow monitoring , page 420	✓	✓	✓	✓	✓
Process underload monitoring , page 479	✓	✓	✓	✓	✓
Process overload monitoring , page 482	✓	✓	✓	✓	✓
Stall monitoring					✓
Thermal sensor monitoring , page 165	✓	✓	✓	✓	✓
Surge voltage limitation	✓	✓	✓	✓	✓
4-20 mA loss , page 546	✓	✓	✓	✓	✓
Safe Torque Off	✓	✓	✓	✓	✓

Combinations of Functions and Display Functions

Function	Application				
	Borehole pump	Pumping station	Boosting station	Miscellaneous	Lift station
Energy parameters , page 81	✓	✓	✓	✓	✓
Data logging , page 129	✓	✓	✓	✓	✓

Basic Functions

Drive Ventilation

If **[Fan mode]** *F F Π* is set to:

- **[Standard]** *S E d*, the operation of the fan is enabled when the motor is running. According to drive rating, this could be the only available setting.
- **[Always]** *r u n*, the fan is always activated.
- **[Economy]** *E C o*, the fan is activated only if necessary, according to the internal thermal state of the drive.

Fan speed and **[Fan Operation Time]** *F P b t* are monitored values:

- An abnormal low speed of the fan triggers a warning **[Fan Feedback Warning]** *F F d H*.
- As soon as **[Fan Operation Time]** *F P b t* reach the predefined value of 45,000 hours, a warning **[Fan Counter Warning]** *F C t H* is triggered.

[Fan Operation Time] *F P b t* counter can be set to 0 by using the **[Time Counter Reset]** *r P r* parameter.

Graphic Display Terminal

Description of the Graphic Display Terminal

This Graphic Display Terminal is a local control unit which can be either plugged on the drive or mounted on the door of the wall-mounted or floor-standing enclosure. It has a cable with connectors, which is connected to the drive front Modbus serial link. The Graphic Display Terminal embeds a real time clock used for the time stamping of logged data and all other functions which require time information.

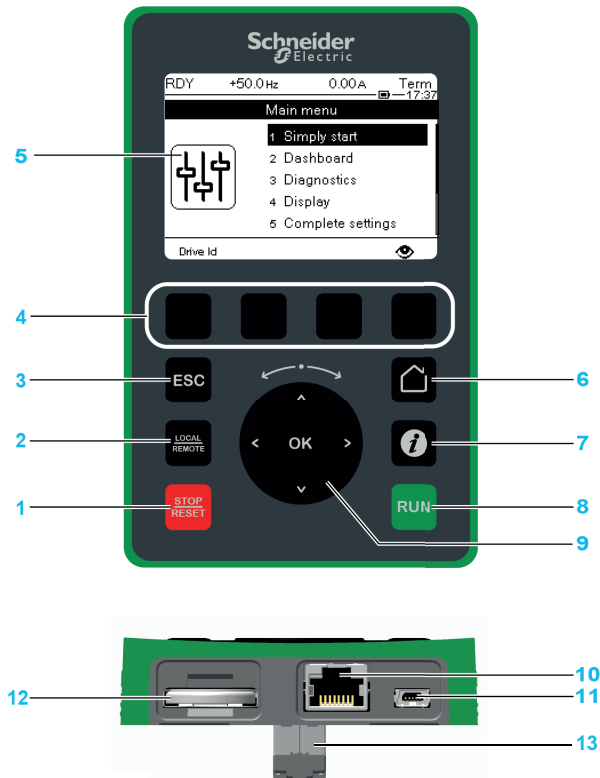

1 STOP / RESET: Stop command / apply a Fault Reset.

2 LOCAL / REMOTE: used to switch between local and remote control of the drive.

3 ESC: used to quit a menu/parameter or remove the currently displayed value in order to revert to the previous value retained in the memory

4 F1 to F4: function keys used to access drive id, QR code, quick view, and submenus. Simultaneous press of F1 and F4 keys generates a screenshot file in the Graphic Display Terminal internal memory.

5 Graphic display.

6 Home: used to access directly at the home page.

7 Information: used to have more information about parameters. The selected parameter code is displayed on the first line of the information page.

8 RUN: executes the function assuming it has been configured.

9 Touch wheel / OK: used to save the current value or access the selected menu/parameter. The touch wheel is used to scroll fast into the menus. Up/down arrows are used for precise selections, right/left arrows are used to select digits when setting a numerical value of a parameter.

10 RJ45 Modbus serial port: used to connect the Graphic Display Terminal to the drive.

11 Mini USB port: used to connect the Graphic Display Terminal to a computer.

12 Battery (10 years service life. Type: CR2032). The battery positive pole points to the front face of the Graphic Display Terminal .

13 RJ45 male connector: used to plug the Graphic Display Terminal on the Altivar or the door mounting kit.

NOTE: Keys 1, 8 and 9 can be used to control the drive if control via the Graphic Display Terminal is activated. To activate the keys on the Graphic Display Terminal , you first need to set **[Ref Freq 1 Config] F r 1** to **[Ref. Freq-Rmt.Term] L C C** .

Description of the Graphic Display

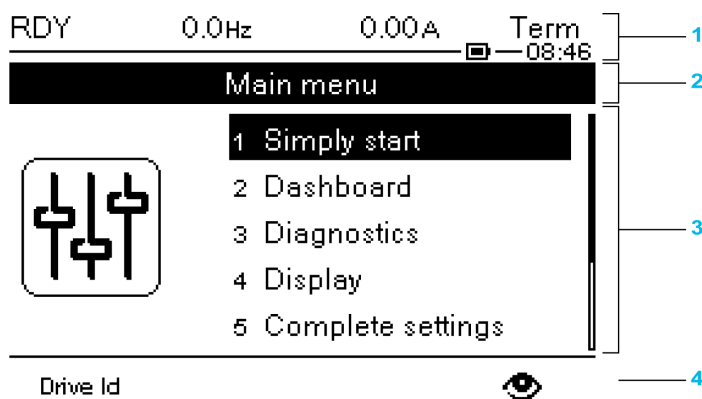

1 Display line: its content can be configured

2 Menu line: indicates the name of the current menu or submenu

3 Menus, submenus, parameters, values, bar charts, and so on, are displayed in drop-down window format on a maximum of five lines. The line or value selected by the navigation button is displayed in reverse video

4 Section displaying tabs (1 to 4 by menu), these tabs can be accessed using F1 to F4 keys

Display line details:

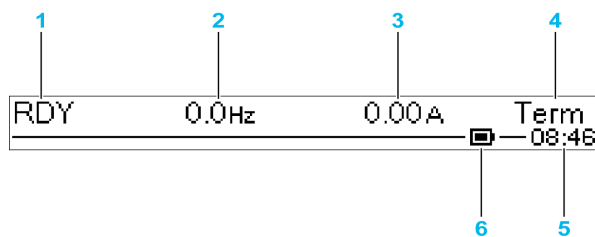

Key	
1	Drive state
2	Customer defined
3	Customer defined
4	Active control channel <ul style="list-style-type: none"> • TERM: terminals • HMI: Graphic Display Terminal • MDB: integrated Modbus serial • CAN: CANopen® • NET: fieldbus module • ETH: integrated Ethernet Modbus TCP
5	Present time
6	Battery level

Description of the Product Front LEDs

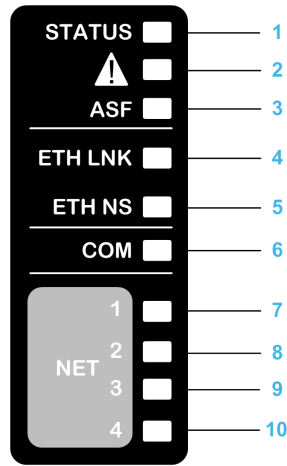

Following table provides the details of the drive status LEDs:

Item	LED	Color & status	Description
1	STATUS	OFF	Indicates that the drive is powered off
		Green flashing	Indicates that the drive is not running, ready to start
		Green blinking	Indicates that the drive is in transitory status (acceleration, deceleration, and so on)
		Green on	Indicates that the drive is running
2	Warning/Error	Red flashing	Indicates that the drive has detected a warning
		Red on	Indicates that the drive has detected an error
3	ASF	Yellow on	Indicates that the safety function has been triggered

Following table provides the details of the embedded Ethernet LEDs:

Item	LED	Color & status	Description
4	ETH LNK	OFF	Indicates that the embedded Ethernet link is not established
		Green on	Indicates that the embedded Ethernet link established at 100 Mbit/s
		Green blinking	Indicates embedded Ethernet fieldbus activity at 100 Mbit/s
		Yellow on	Indicates that the embedded Ethernet link established at 10 Mbit/s
		Yellow blinking	Indicates embedded Ethernet fieldbus activity at 10 Mbit/s
5	ETH NS	OFF	Indicates that the embedded Ethernet has no IP address
		Green/Red flashing	Indicates power on testing
		Green on	Indicates that the embedded Modbus TCP connection is established to the command word
		Green flashing	Indicates that the embedded Ethernet has a valid IP, but no Modbus TCP connection to the command word
		Red on	Indicates that the embedded Ethernet has detected a duplicated IP address
		Red	Indicate that the embedded Modbus TCP connection established to control the command word is closed or timed out

Following table provides the details of the embedded Modbus serial LEDs:

Item	LED	Color & status	Description
6	COM	Yellow flashing	Indicates embedded Modbus serial activity

Following table provides the details of the fieldbus module LEDs:

Item	LED	Color & status	Description
7	NET 1	Green/Yellow	for details, refer to the fieldbus manual
8	NET 2	Green/Red	for details, refer to the fieldbus manual
9	NET 3	Green/Red	for details, refer to the fieldbus manual
10	NET 4	Green/Yellow	for details, refer to the fieldbus manual

Graphic Display Terminal Connected to a Computer

NOTICE
<p>INOPERATIVE EQUIPMENT</p> <p>Do not connect equipment to the RJ45 port and to the USB port of the Graphic Display Terminal at the same time.</p> <p>Failure to follow these instructions can result in equipment damage.</p>

The Graphic Display Terminal is recognized as a USB storage device named SE_VW3A1111 while plugged on a computer.

This allows to access the saved drive configurations (*DRVCONF* folder) and the Graphic Display Terminal screenshots (*PRTSCR* folder).

Screenshots can be stored by a simultaneous press on *F1* and *F4* function keys

How To Update Language Files on the Graphic Display Terminal

The Graphic Display Terminal (VW3A1111) language files can be updated.

Download the latest version of language files here: [Languages_Drives_VW3A1111](#)

The following table describe the procedure to update the language files of the Graphic Display Terminal:

Action	Step
1	Download the latest version of language files here: Languages_Drives_VW3A1111
2	Save the downloaded file on your computer.
3	Unzip the file and follow the instructions of the ReadMe text file.

How to customize the logo displayed at power on of the Graphic Display Terminal?

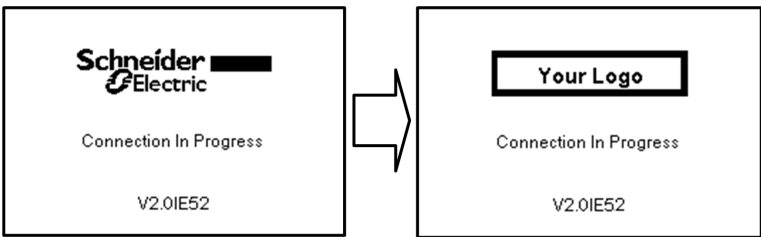

From the firmware version V2.0 of the Graphic Display Terminal, the logo displayed at power on by the Graphic Display Terminal can be customized. By default, the Schneider-Electric logo is displayed.

To modify the displayed logo, you must:

- Create your own logo and save it as a bitmap file (.bmp) with the name logo_init. The logo must be saved in black & white and the dimensions must be 137x32 pixels.
- Connect the Graphic Display Terminal to a computer via an USB cable.
- Copy your logo (logo_init.bmp) in the folder KPCONFIG of the Graphic Display Terminal.

At next power on of the Graphic Display Terminal connected to the drive, your own logo should be displayed.

If the logo of Schneider-Electric is still displayed, verify the characteristics of your file and the location where it has been copied.

Multipoint Screen

Overview

Generally, a Graphic Display Terminal is connected to only one drive. However, communication is possible between a Graphic Display Terminal and several Altivar drives (ATV320, ATV340, ATV600, and ATV900) connected on the same Modbus serial fieldbus via the RJ45 port (HMI or Modbus serial). In such a case, the multipoint mode is automatically applied on the Graphic Display Terminal.

The multipoint mode allows you to:

- Have an overview of all the drives connected on the fieldbus (drive state and two selected parameters).
- Access to all the menus of each drive connected on the fieldbus.
- Command a stop on all the connected drives with the STOP/RESET key (irrespective of the present screen displayed). The type of stop can be individually configured on each drive with the parameter **[Stop Key Enable]** *P 5 E* in the menu **[Command and Reference]** *L r P -*, page 228.

Apart the Stop function linked to the STOP/RESET key, the multipoint mode does not allow to apply a Fault Reset and command the drive via the Graphic Display Terminal: in multipoint mode, the Run key and the Local/Remote key are deactivated.

Prerequisites

To use the multipoint mode:

- The Graphic Display Terminal software version must be equal to or higher than V2.0.
- For each drive, the command channel and the reference channel must be set in advance to a value different from **[Ref.Freq-Rmt.Term]** *L C C*, page 228.
- The address of each drive must be configured in advance to different values by setting the parameter **[Modbus Address]** *P d d* in the **[Modbus Fieldbus]** *P d I -*.
- If the connection to the drive is done via the HMI RJ45 port, the parameter settings in **[Modbus HMI]** *P d C -* must be compliant with the Graphic Display Terminal usage.
- If the connection to the drive is done via the Modbus serial RJ45 port, the parameter settings in **[Modbus Fieldbus]** *P d I -* must be compliant with the Graphic Display Terminal usage.

Example of Installation Topology

The following figure gives a topology example using four drives, a Modbus “T” tap-off (VW3A8306TF03) and one Graphic Display Terminal (VW3A1111) linked to one Modbus splitter block (LU9GC3):

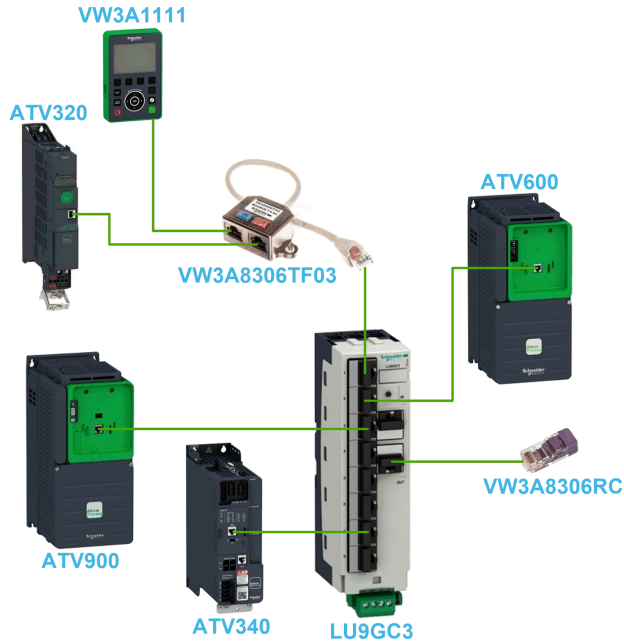

Screens for Multipoint Mode

The following figure gives the browsing between the different screens linked to the multipoint mode:

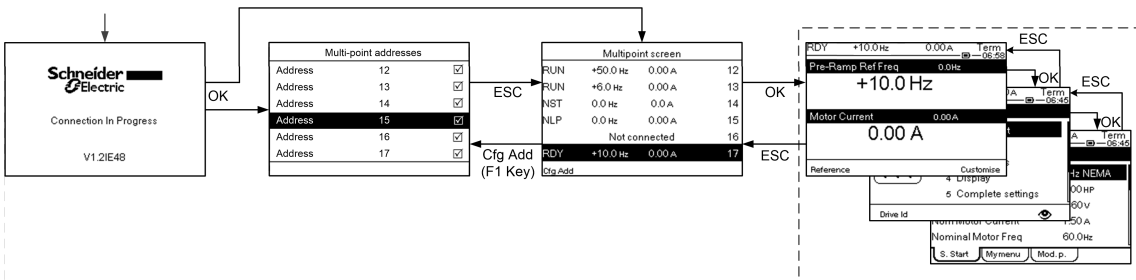

On the fieldbus common with the Graphic Display Terminal, if two or more drives are powered on, you access to the **[connection in progress]** screen. If there is no address selected by the Graphic Display Terminal or no recognized address, the Graphic Display Terminal is locked on this screen. Press OK key to access to the **[Multi-point Addresses]** screen. Otherwise, if there are addresses-selected and one of them have been recognized by the Graphic Display Terminal, the screen switches automatically to **[Multipoint screen]**.

The **[Multi-point Addresses]** screen allows to select, by pressing OK key, the addresses of the drives you want to connect with. Up to 32 addresses can be selected (address setting range: 1...247). When all the addresses have been selected, press ESC key to access to the **[Multipoint screen]**.

NOTE: To help to prevent a low refresh rate of the Graphic Display Terminal screen, do not select addresses that are not corresponding to drive addresses.

On the **[Multipoint screen]**, the touch wheel is used to navigate between the drive overviews. Access to the menus of the selected drive by pressing OK key. Return to the **[Multipoint screen]** by pressing ESC key.

NOTE: To access the **[Multi-point Addresses]** screen from the **[Multipoint screen]**, press F1 key.

If a drive triggers an error, the Graphic Display Terminal goes automatically to the **[Multipoint screen]** on the overview of the latest drive who has triggered an error.

The two parameters given in the drive overview can be modified individually on each drive in **[Param. Bar Select] [PbS-]** menu, page 603.

Structure of the Parameter Table

General Legend

Pictogram	Description
★	These parameters only appear if the corresponding function has been selected in another menu. When the parameters can also be accessed and adjusted from within the configuration menu for the corresponding function, their description is detailed in these menus, on the pages indicated, to aid programming.
()	Setting of this parameter can be done during operation or when stopped. NOTE: It is advisable to stop the motor before modifying any of the settings.
⌚	To modify the assignment of the parameter, reinforced validation is required.

Parameter Presentation

Below is an example of a parameter presentation:

[Sample Menu] C o d E – Menu

Access

Parameters described below can be accessed by:

[Path] → [Sub-path]

About this menu

Description of the menu or function

[Parameter1] C o d E I

Description of the parameter

Example of a table with a setting range:

Setting ()	Description
0.0... 10,000.0	Setting range Factory setting: 50.0

[Parameter2] C o d E 2

Description of the parameter

Example of a table with a list of choices:

Setting ()	Code / Value	Description
[50 Hz IEC]	5 0	IEC Factory setting
[60 Hz NEMA]	6 0	NEMA

Finding a Parameter in This Document

With the Graphic Display Terminal

Select the required parameter and press .

The parameter code is displayed at the top of the information window.

Example: **[Acceleration]** code is *R C C*.

With the Manual

It is possible to use either the parameter name or the parameter code to search in the manual the page giving details of the selected parameter.

Difference Between Menu and Parameter

A dash after menu and submenu codes is used to differentiate menu commands from parameter codes.

Example:

Level	Name	Code
Menu	[Ramp]	<i>r R P P -</i>
Parameter	[Acceleration]	<i>R C C</i>

Cyber Security

What's in This Chapter

Overview	44
Password	50
Upgrades Management	51

Overview

The objective of Cybersecurity is to help provide increased levels of protection for information and physical assets from theft, corruption, misuse, or accidents while maintaining access for their intended users.

No single Cybersecurity approach is adequate. Schneider Electric recommends a defense-in-depth approach. Conceived by the National Security Agency (NSA), this approach layers the network with security features, appliances, and processes.

The basic components of this approach are:

- Risk assessment
- A security plan built on the results of the risk assessment
- A multi-phase training campaign
- Physical separation of the industrial networks from enterprise networks using a demilitarized zone (DMZ) and the use of firewalls and routing to establish other security zones
- System access control
- Device hardening
- Network monitoring and maintenance

This chapter defines the elements that help you configure a system that is less susceptible to cyber-attacks.

Network administrators, system integrators and personnel that commission, maintain or dispose of a device should:

- Apply and maintain the device's security capabilities. See Device Security Capabilities sub-chapter for details
- Review assumptions about protected environments. See Protected Environment Assumptions sub-chapter for details
- Address potential risks and mitigation strategies. See Product Defense-in-Depth sub-chapter for details
- Follow recommendations to optimize cybersecurity

For detailed information on the system defense-in-depth approach, refer to the TVDA: How Can I Reduce Vulnerability to Cyber Attacks in the Control Room (STN V2) on se.com.

To submit a Cybersecurity question, report security issues, or get the latest news from Schneider Electric, visit the [Schneider Electric website](#).

⚠ WARNING

POTENTIAL COMPROMISE OF SYSTEM AVAILABILITY, INTEGRITY, AND CONFIDENTIALITY

- Change default password to help prevent unauthorized access to device settings and information.
- Disable unused ports/services and default accounts, where possible, to minimize pathways for malicious attacks.
- Place networked devices behind multiple layers of cyber defenses (such as firewalls, network segmentation, and network intrusion detection and protection).
- Use cybersecurity best practices (for example: least rights, separation of duties) to help prevent unauthorized exposure, loss or modification of data and logs, interruption of services, or unintended operation.

Failure to follow these instructions can result in death, serious injury, or equipment damage.

Protected Environment Assumptions

Machines, controllers, and related equipment are usually integrated into networks. Unauthorized persons and malware may gain access to the machine as well as to other devices on the network/fieldbus of the machine and connected networks via insufficiently secure access to software and networks.

⚠ WARNING

UNAUTHORIZED ACCESS TO THE MACHINE VIA SOFTWARE AND NETWORKS

- In your hazard and risk analysis, consider all hazards that result from access to and operation on the network/fieldbus and develop an appropriate cyber security concept.
- Verify that the hardware infrastructure and the software infrastructure into which the machine is integrated as well as all organizational measures and rules covering access to this infrastructure consider the results of the hazard and risk analysis and are implemented according to best practices and standards covering IT security and cyber security (such as: ISO/IEC 27000 series, Common Criteria for Information Technology Security Evaluation, ISO/IEC 15408, IEC 62351, ISA/IEC 62443, NIST Cybersecurity Framework, Information Security Forum - Standard of Good Practice for Information Security, SE recommended Cybersecurity Best Practices*).
- Verify the effectiveness of your IT security and cyber security systems using appropriate, proven methods.

Failure to follow these instructions can result in death, serious injury, or equipment damage.

(*) : SE Recommended Cybersecurity Best Practices can be downloaded on [SE.com](#).

Before considering cybersecurity practices on the device, please pay attention to following points:

- Cybersecurity governance – available and up-to-date guidance on governing the use of information and technology assets in your company.
- Perimeter security – installed devices, and devices that are not in service, are in an access-controlled or monitored location.

- Emergency power – the control system provides the capability to switch to and from an emergency power supply without affecting the existing security state or a documented degraded mode.
- Firmware upgrades – the ATV600 upgrades are implemented consistently to the current version of firmware available on request from Schneider Electric Customer Care Center.
- Controls against malware – detection, prevention, and recovery controls to help protect against malware are implemented and combined with appropriate user awareness.
- Physical network segmentation – the control system provides the capability to:
 - Physically segment control system networks from non-control system networks.
 - Physically segment critical control system networks from non-critical control system networks.
- Logical isolation of critical networks – the control system provides the capability to logically and physically isolate critical control system networks from non-critical control system networks. For example, using VLANs.
- Independence from non-control system networks – the control system provides network services to control system networks, critical or non-critical, without a connection to non-control system networks.
- Encrypt protocol transmissions over all external connections using an encrypted tunnel, TLS wrapper or a similar solution.
- Zone boundary protection – the control system provides the capability to:
 - Manage connections through managed interfaces consisting of appropriate boundary protection devices, such as: proxies, gateways, routers, firewalls, and encrypted tunnels.
 - Use an effective architecture, for example, firewalls protecting application gateways residing in a DMZ.
 - Control system boundary protections at any designated alternate processing sites should provide the same levels of protection as that of the primary site, for example, data centers.
- No public internet connectivity – access from the control system to the internet is not recommended. If a remote site connection is needed, for example, encrypt protocol transmissions.
- Resource availability and redundancy – ability to break the connections between different network segments or use duplicate devices in response to an incident.
- Manage communication loads – the control system provides the capability to manage communication loads to mitigate the effects of information flooding types of DoS (Denial of Service) events.
- Control system backup – available and up-to-date backups for recovery from a control system failure

Security Policy

⚠ WARNING
<p>ACCESSIBILITY LOSS</p> <ul style="list-style-type: none"> • Setup a security policy to your device and backup the device image with security administrator user account. • Define and regularly review the password policy. • Periodic change of the passwords, Schneider Electric recommends a modification of the password each 90 days. <p>Failure to follow these instructions can result in death, serious injury, or equipment damage.</p>

Cybersecurity helps to provide:

- Confidentiality (to help prevent unauthorized access)
- Integrity (to help prevent unauthorized modification)
- Availability/authentication (preventing the denial of service and assuring authorized access)
- Non-repudiation (preventing the denial of an action that took place)
- Traceability/detection (logging and monitoring)

For an efficient security, the instructions and procedures should structure the roles and responsibilities in terms of security within the organization, in other words, who is authorized to perform what and when? These should be known by the users.

The anti-intrusion and anti-physical access to any sensitive installation should be set up.

All the security rules implemented in the ATV600 are in complement of the points above.

The device does not have the capability to transmit data encrypted using the following protocols: HTTP, Modbus slave over serial, Modbus slave over Ethernet, EtherNet/IP, SNMP, SNTP. If other users gained access to your network, transmitted information can be disclosed or subject to tampering.

⚠ WARNING
<p>CYBERSECURITY HAZARD</p> <ul style="list-style-type: none"> • For transmitting data over an internal network, physically or logically segment the network, the access to the internal network needs to be restricted by using standard controls such as firewalls. • For transmitting data over an external network, encrypt protocol transmissions over all external connections using an encrypted tunnel, TLS wrapper or a similar solution. <p>Failure to follow these instructions can result in death, serious injury, or equipment damage.</p>

The access through the digital inputs is not controlled.

Any computer using SoMove, DTM, Webserver or EcoStruxure Control Expert should have an updated anti-virus, anti-malware, anti-ransomware application activated during the use.

The ATV600 have the capability to export its settings and files manually or automatically. It is recommended to archive any settings and files (device backup images, device configuration, device security policies) in a secure area.

Product Defense-in-Depth

Use a layered network approach with multiple security and defense controls in your IT and control system to minimize data protection gaps, reduce single-points of failure and create a strong cybersecurity posture. The more layers of security in your network, the harder it is to breach defenses, take digital assets or cause disruption.

Device Security Capabilities

ATV600 offers the following security features:

Threats	Desired security property on Embedded Device	security features
Information disclosure	Confidentiality	Password encrypted in a non-reversible way
		User access control
Denial of Service	Availability	Device backup/restore
		Achilles Level 2
Spoofing/Elevation of privilege	User Authenticity / Authorization	Strong password policy
		Access control commissioning tools Modbus TCP
		Access control commissioning tools Web Server

Confidentiality

Information confidentiality capacity prevents unauthorized access to the device and information disclosure.

- The user access control helps on managing users that are authorized to access the device. Protect user credential at usage.
- The user's passwords are encrypted in non-reversible way at rest

Information affecting the security policy of the device is encrypted in transit.

Device Integrity Protection

The device integrity protection prevents unauthorized modification of the device with tampered or spoofed information.

This security capability helps protect the authenticity and integrity of the firmware running on the ATV600 and facilitates protected file transfer: digitally signed firmware is used to help protect the authenticity of the firmware running on the ATV600 and only allows firmware generated and signed by Schneider Electric.

- Cryptographic signature of the firmware package executed at the firmware update

Availability

The control system backup is essential for recovery from a control system failure and/or misconfiguration and participate on preventing denial of service. It also helps ensure global availability of the device by reducing operator overhead on security application/deployment.

These security capabilities help manage control system backup with the device:

- Complete device backup/restore available on local HMI, DTM and FDR. Regarding the communication robustness, the ATV600 embedded Ethernet fieldbus and option module successfully passed the certification Achilles L2.

User Authenticity and Authorization

The user authentication helps prevent the repudiation issue by managing user identification and prevents information disclosure and device integrity issues by unauthorized users.

These security capabilities help enforce authorizations assigned to users, segregation of duties and least rights:

- User authentication is used to identify and authenticate software processes and devices managing accounts
- Device Password policy and password strength configurable using SoMove, DTM or EcoStruxure Control Expert
- Authorization managed according to channels

In line with user authentication and authorization, the device has access control cryptographic features to check user credential before access is granted to the system.

In the ATV600, the control of accessibility to the settings, parameters, configuration, and logging database is done with a user authentication after "Log in", with a name and password.

The ATV600 controls the access through:

- SoMove DTM (Ethernet connection)
- The webserver
- EcoStruxure Control Expert

Potential Risks and Compensating Controls

Address potential risks using these compensating controls:

Area	Issue	Risk	Compensating controls
User accounts.	Default account settings are often the source of unauthorized access by malicious users.	If you do not change default password or disable the user access control, unauthorized access can occur.	Ensure User access control is enabled on all the communication ports and change the default passwords to help reduce unauthorized access to your device.
Secure protocols.	Modbus serial, Modbus TCP, EtherNet/IP, SNMP, SNT, HTTP protocols are insecure. The device does not have the capability to transmit data encrypted using these protocols.	If a malicious user gained access to your network, they could intercept communication.	For transmitting data over internal network, physically or logically segment your network. For transmitting data over external network, encrypt protocol transmissions over all external connections using an encrypted tunnel, TLS wrapper or a similar solution. See Protected Environment Assumptions, page 45.

Data Flow Restriction

A firewall device is required to secure the access to the device and limit the data flow.

For detailed information, refer to the TVDA: How Can I Reduce Vulnerability to.

Cyber Attacks in the Control Room (STN V2) on the Schneider Electric website.

Password

Changing Password

The user password can be changed from the DTM Admin options screen

Reset Password

The password is accessible in the graphic display terminal by default.

The ATV600 stores password in a secure non-reversible format. It is impossible to retrieve a password that has been lost by his user.

For ADMIN user, a special operation is available with the display terminal to reset the ADMIN password to a default value unique to the device.

To reset the ADMIN password:

Step	Action
1	Navigate in the menu [Communication] $C \ o \ n$ - \rightarrow [Comm parameters] $C \ n \ p$ - \rightarrow [Embd Eth Config] $E \ t \ e$ - \rightarrow [User authentication] $S \ e \ c \ e$. Note: If you are using an ATV600 with an option module, you can navigate in the menu [Communication] $C \ o \ n$ - \rightarrow [Comm parameters] $C \ n \ p$ - \rightarrow [Eth Module Config] $E \ t \ o$ - \rightarrow [User authentication] $S \ e \ c \ o$.
2	Scroll to the parameter [Reset Eth Emb Pwd] $r \ w \ p \ e$ and press OK . Note: If you are using an ATV600 with an option module, you can select the parameter [Reset Eth Opt Pwd] $r \ w \ p \ o$.
3	The default password is visible on the graphic display terminal until the ADMIN modifies it.

Upon first use, the commissioning tools and webserver will request the user to change this password prior to connecting. The cybersecurity policy does not change when the password is reset.

Password Policy

By default, the password policy of the ATV600 complies with IEEE 1686–2013 as following:

- 8 characters minimum with ASCII [32 to 122] characters
- At least one digit (0-9)
- At least one special character (for example @, \$)

In addition, for password changes, the password history is saved and prevents the reuse of a password that has been set at least once in the last 5 times.

The password policy can be customized or totally disabled to match with password policy in place in the system of which the device is part.

The following settings are available:

- Password policy: enabled/disabled. If disabled, a password is requested as authentication factor but there is no specific rule defined regarding the password robustness
- Password history: No restriction, Exclude last 3, Exclude last 5
- Special character required: YES/NO
- Numeric character required: YES/NO
- Alphabetic character required: YES/NO

- Minimum password length: any value between 6 and 20

This password policy customization can only be done with SoMove, DTM or EcoStruxure Control Expert. Please refer to DTM online help for details.

Upgrades Management

When the ATV600 firmware is upgraded, security configuration remains the same until changed, including usernames and passwords.

It is recommended that security configuration is reviewed after an upgrade to analyze rights for new or changed device features and revoke or apply them according to your company's policies and stand

Programming

What's in This Part

[Simply start] <i>S Y S</i> -	53
[Dashboard] <i>d S H</i> -	57
[Diagnostics] <i>d i A</i> -	73
[Display] <i>Π α η</i> -	80
[Complete settings] <i>Ε S Ε</i> -	133
Communication.....	588
[File management] <i>F Π Ε</i> -	590
[My preferences] <i>Π Υ Ρ</i> -	597

[Simply start] 5 4 5 -

What's in This Chapter

[Simply start] 5 , 11 - Menu	54
[My menu] 11 4 11 11 - Menu	56
[Modified parameters] 11 11 11 - Menu	56

Introduction



[Simply start] 5 4 5 - menu contains 3 tabs for quick access to mains features:

- Simply Start tab which gives a quick access to basic parameters to set.
- My Menu tab which is a user-defined menu for quick access to specific parameters.
- Modified Parameters tab which gives a quick access to the 10 last modified parameters.

[Simply start] 5 , 7 - Menu

Access

[Simply start] → [Simply start]

About This Menu

⚠ WARNING
<p>LOSS OF CONTROL</p> <ul style="list-style-type: none"> Fully read and understand the manual of the connected motor. Verify that all motor parameters are correctly set by referring to the nameplate and the manual of the connected motor. If you modify the value of one or more motor parameters after having performed autotuning, the value of [Tune selection] <i>STUN</i> is reset to [Default] <i>TAB</i> and you must re-perform autotuning. <p>Failure to follow these instructions can result in death, serious injury, or equipment damage.</p>

This menu provides a quick access to basic parameters to set in case of a single asynchronous motor in open loop control.

NOTE: On Graphic Display Terminal (VW3A1111), **[Simply start] 5 , 7 -** is the first tab displayed in the **[Simply start] 5 4 5 -** menu (the tab name is “S. Start”).

For more information on the setting of the parameters present in this menu or to set your drive in another use case (such as synchronous motor and/or with specific functions) refer to **[Complete settings] 6 5 6 -** menu.

NOTE: To help set basic parameters of the drive, a dedicated view exists in SoMove/DTM.

The following table shows a standard procedure for a simply start configuration of the drive used with an asynchronous motor in open loop control. This procedure only uses the basic parameters that can be accessed in this menu:

Step	Parameter	Menu	Description	Factory setting
1 – Motor Standard	[Motor Standard] <i>b F r</i> ⁽¹⁾	[Data] <i>7 6 d -</i>	Help to preset the drive parameters and units according to the standard 50 Hz IEC or 60 Hz NEMA. NOTE: First parameter to modify. Otherwise, the drive configuration must be performed again.	[50 Hz] <i>5 0</i> ⁽⁷⁾
2 – Motor nameplate	[Nominal Motor Power] <i>n P r</i> ⁽¹⁾	[Data] <i>7 6 d -</i>	Set these parameters according to the motor nameplate. By default, [Motor 1 Cosinus Phi] <i>6 0 5</i> does not need to be entered. To enter the motor nameplate using <i>6 0 5</i> , the parameter [Motor param choice] <i>7 6 6</i> must be set to [Mot Cosinus] <i>6 0 5</i> . In this case, [Nominal motor power] <i>n P r</i> does not need to be entered.	- ⁽⁴⁾
	[Nom Motor Voltage] <i>u n 5</i> ⁽¹⁾			- ⁽⁴⁾
	[Nom Motor Current] <i>n 6 r</i> ⁽¹⁾			- ⁽⁴⁾
	[Nominal Motor Freq] <i>F r 5</i> ⁽¹⁾			50 Hz ⁽⁶⁾
	[Nominal Motor Speed] <i>n 5 P</i> ⁽¹⁾			- ⁽⁴⁾
	[Motor 1 Cosinus Phi] <i>6 0 5</i> ^{(1) (2)}			- ⁽⁴⁾
	[Motor Th Current] <i>i 6 H</i>	- ⁽⁴⁾		
3 – Type of wiring	[2/3–Wire Control] <i>6 6 6</i>	[Com- mand and	Select between 2-wire and 3-wire control.	[2–Wire Control] <i>2 6</i>

Step	Parameter	Menu	Description	Factory setting
		reference] C r P -		
4 — Maximum motor frequency	[Max Frequency] E F r	[Data] n E d -	Maximum output frequency.	60 Hz ⁽⁵⁾
5 — Standstill motor tune	[Autotuning] E u n	[Motor tune] n E u -	Use to perform a standstill motor tune (autotuning) to measure internal motor characteristics. Set [Autotuning] E u n to [Apply Autotuning] y E 5 in order to start the standstill motor tune. E u n and S E u n are used to monitor the tune status. NOTE: If you modify the value of one or more motor parameters after having performed autotuning, you must re-perform autotuning.	[No Action] n o
	[Autotuning Status] E u S			[Not Done] E A b ⁽³⁾
	[Tune Selection] S E u n			[Default] E A b ⁽³⁾
6 — Dynamics and limits of the reference	[Acceleration] A C C	[Ramp] r A n P -	Time to accelerate from 0 Hz to [Nominal Motor Freq] F r 5 and time to decelerate from [Nominal Motor Freq] F r 5 to 0 Hz. NOTE: To have a repeatability in the ramps, the value of these parameters must be set according to the possibility of the application (for example the inertia must be considered).	10.0 s
	[Deceleration] d E C			10.0 s
	[Low Speed] L S P	[Speed limits] S L n -	Minimum motor frequency reference. NOTE: The setting of this parameter must not be modified during the learning phase in the vortex control , page 382 (i.e [Curve learn mode] v C L n is set to [Learnt curve mode] L E A r n). If setting modified, it is recommended to restart the learning.	0.0 Hz
	[High Speed] H S P		Maximum motor frequency reference. NOTE: The setting of this parameter must not be modified during the learning phase in the vortex control , page 382 (i.e [Curve learn mode] v C L n is set to [Learnt curve mode] L E A r n). If setting modified, it is recommended to restart the learning.	50.0 Hz ⁽⁶⁾

(1): This parameter can only be accessed with asynchronous motor control law.
 (2): The access to this parameter depends on [Motor Param Choice] n P C . This parameter can be accessed in [Data] n E d - menu.
 (3): Read-only parameter.
 (4): The factory setting, the unit and/or the increment is impacted by the drive rating and/or [Motor Standard] b F r .
 (5): The factory setting value is changed to 72 Hz if [Motor Standard] b F r is set to [60 Hz NEMA] E D .
 (6): The factory setting value is changed to 60 Hz if [Motor Standard] b F r is set to [60 Hz NEMA] E D .
 (7): The factory setting value is changed to [60 Hz NEMA] E D for ATV●30●●●S6● catalog numbers.

[My menu] П У П П - Menu

Access

[Simply start] → [My menu]

About This Menu

This menu contains the parameters selected in the [My menu config.] П У П - Menu, page 602.

NOTE: This menu is empty by default.

[Modified parameters] L П П - Menu

Access

[Simply start] → [Modified parameters]

About This Menu

This menu gives a quick access to the 10 last modified parameters.

[Dashboard] d S H -

What's in This Chapter

[Pump dashboard] P P L - Menu	58
[Fan dashboard] F A n - Menu.....	61
[Dashboard] d S H - Menu	63
[Control] L E r - Menu.....	64
[Control] F E r - Menu.....	68
[Dashboard] d S H - Menu	69
[kWh Counters] K W C - menu.....	70
[Dashboard] d S H - Menu	72

Introduction



[Dashboard] d S H - menu contains tabs for quick access to system and display features:

- System tab to configure the main system parameters.
- Energy tab which provides a complete access for instantaneous power counters and energy reports by means of graphics on the Graphic Display Terminal.

[Pump dashboard] P Π E - Menu

Access

[Dashboard] → [Pump dashboard]

About This Menu

This menu provides informations related to the pump.

This menu can be accessed if **[Application Selection] R P P E** is not set to **[Generic Fan Control] F R n**.

[Pre-Ramp Ref Freq] F r H

Frequency reference before ramp (signed value).

Actual frequency reference linked to the motor regardless of which channel for reference value has been selected. This parameter is in read-only mode.

Setting	Description
-[High Speed] H S P...[High Speed] H S P Hz	Setting range Factory setting: –

[Drive State] H Π , S

Drive state.

Setting	Code / Value	Description
[Autotuning]	E u n	Autotuning
[In DC inject.]	d C b	DC Injection
[Ready]	r d y	Drive ready
[Freewheel]	n S t	Freewheel stop control
[Running]	r u n	Motor in steady state or run command present and zero reference
[Accelerating]	A C C	Acceleration
[Decelerating]	d E C	Deceleration
[Current limitation]	C L i	In current limitation
[Fast stop]	F S t	Fast stop
[No Mains Voltage]	n L P	Control is powered on but the DC bus is not loaded
[control.stop]	C t L	Controlled stop
[Dec. adapt.]	a b r	Adapted deceleration
[Output cut]	S o C	Stand by output cut
[Undervoltage Warning]	u S R	Undervoltage warning
[“Operating State “Fault”“]	F L t	Product has detected an error

Setting	Code / Value	Description
[DCP Flashing Mode]	d C P	DCP flashing mode
[STO Active]	S t o	Safe Torque Off active
[Energy Saving]	i d L E	Idle stop and go mode
[Firmware Update]	F W u P	Firmware update
[AFE Mains Undervoltage]	u r R	Displayed if the voltage applied on the Active Front End power brick exceeds the [Mains Voltage] u r E S, the drive stops on [Freewheel Stop] n S t.

[MultiPump State] n P S ★

Multipump function state.

This parameter can be accessed if [Pump System Archi] n P S R is not set to [No] n o.

Setting	Code / Value	Description
[None]	n o n E	None
[Ready]	r E A d Y	Ready
[Running]	r u n	Running
[Warning]	A L A r n	Warning
[Error]	F A u L t	Error
[Not Available]	n A V L	Not available

[Available Pumps] n P A n ★

Number of available pumps.

This parameter can be accessed if [Pump System Archi] n P S R is not set to [No] n o.

Setting	Description
0...[Nb Of Pumps] n P P n	Setting range Factory setting: -

[Nb of Staged Pumps] n P S n ★

Number of staged pumps.

This parameter can be accessed if [Pump System Archi] n P S R is not set to [No] n o.

Setting	Description
0...[Nb Of Pumps] n P P n	Setting range Factory setting: -

[Motor Current] *L C r*

Motor current.

Setting	Description
According to drive rating	Setting range Factory setting: –

[Motor speed] *S P d*

Motor speed in rpm.

This parameter displays the estimated rotor speed without motor slip.

Setting	Description
0...65,535 rpm	Setting range Factory setting: –

[Motor Therm state] *L H r*

Motor thermal state.

The normal motor thermal state is 100%, the **[Motor Overload]** *a L F* threshold is set to 118%.

Setting	Description
0...200%	Setting range Factory setting: –

[Fan dashboard] F R n - Menu

Access

[Dashboard] → [Fan dashboard]

About This Menu

This menu provides informations related to the fan.

This menu can be accessed if [Application Selection] R P P L is set to [Generic Fan Control] F R n.

[Pre-Ramp Ref Freq] F r H

Frequency reference before ramp (signed value).

Actual frequency reference linked to the motor regardless of which channel for reference value has been selected. This parameter is in read-only mode.

Setting	Description
-[High Speed] H S P ..[High Speed] H S P Hz	Setting range Factory setting: –

[Drive State] H n , 5

Drive state.

Setting	Code / Value	Description
[Autotuning]	t u n	Autotuning
[In DC inject.]	d C b	DC Injection
[Ready]	r d y	Drive ready
[Freewheel]	n S t	Freewheel stop control
[Running]	r u n	Motor in steady state or run command present and zero reference
[Accelerating]	A C C	Acceleration
[Decelerating]	d E C	Deceleration
[Current limitation]	C L i	In current limitation
[Fast stop]	F S t	Fast stop
[No Mains Voltage]	n L P	Control is powered on but the DC bus is not loaded
[control.stop]	C t L	Controlled stop
[Dec. adapt.]	a b r	Adapted deceleration
[Output cut]	S o C	Stand by output cut
[Undervoltage Warning]	u S A	Undervoltage warning
[“Operating State “Fault”“]	F L t	Product has detected an error

Setting	Code / Value	Description
[DCP Flashing Mode]	d C P	DCP flashing mode
[STO Active]	S t o	Safe Torque Off active
[Energy Saving]	i d L E	Idle stop and go mode
[Firmware Update]	F w u P	Firmware update
[AFE Mains Undervoltage]	u r R	Displayed if the voltage applied on the Active Front End power brick exceeds the [Mains Voltage] u r E S, the drive stops on [Freewheel Stop] n S t.

[Motor Current] L C r

Motor current.

Setting	Description
According to drive rating	Setting range Factory setting: –

[Motor speed] S P d

Motor speed in rpm.

This parameter displays the estimated rotor speed without motor slip.

Setting	Description
0...65,535 rpm	Setting range Factory setting: –

[Motor Therm state] t H r

Motor thermal state.

The nominal motor thermal state is 100%, the [Motor Overload] o L F threshold is set to 118%.

Setting	Description
0...200%	Setting range Factory setting: –

[Dashboard] d S H - Menu

Access

[Dashboard]

About This Menu

Using **F4** function key on the Graphic Display Terminal, it is possible to select one of the following view for the **[Pump dashboard]** or **[Fan dashboard]** tab.

Pump curves and actual working point are available if valid pump characteristics have been entered and if **[Pump Curve Activate] P C H** is set to **[Yes] Y E S**.

[Operating time report] H o t

Displays the operating time histogram.

[Nb start report] H n S

Displays the number of start histogram.

[Power vs Flow] C P q

This shows the mechanical power versus the flow curve of the system.

[Head vs Flow] C H q

This shows the head of the pump versus the flow curve of the system.

[Efficiency vs Flow] C E q

This shows the efficiency (%) versus flow curve of the system.

[Efficiency] E F F

Displays the instantaneous efficiency curve.

[Control] C T r - Menu

Access

[Dashboard] → [Control]

About This Menu

This menu can be accessed if [Application Selection] *A P P L* is not set to [Generic Fan Control] *F A n*.

[System App State] A P S S

System application state.

This parameter indicates the installation application state.

This parameter can be accessed if [Pump System Archi] *P P S A* is set to [Multi Drives] *n V S d* or [Multi Masters] *n V S d r*.

Setting	Code / Value	Description
[Running]	<i>r u n</i>	No application function in progress; the drive is running
[Stop]	<i>S t o p</i>	No application function in progress; the drive is not running
[Manual Mode Active]	<i>Π A n u</i>	Motor running; manual PID mode is active
[PID Active]	<i>A u t o</i>	Motor running; auto PID mode is active
[Flow Limit In Progress]	<i>F L , Π</i>	The flow limitation is in progress
[PipeFill In Progress]	<i>F , L L</i>	The pipe fill is in progress
[Jockey Pump Active]	<i>J o c k e y</i>	The jockey pump is active
[Boost In progress]	<i>b o o s t</i>	The boost is in progress
[Sleep Active]	<i>S L E E P</i>	The sleep is active
[Priming Pump Active]	<i>P r , Π</i>	The priming pump is active
[InletPres Comp In Progress]	<i>C o Π P</i>	The inlet pressure compensation is in progress
[VxCtrl Learning]	<i>V L E A r n</i>	Vortex control learning is in progress
[VxCtrl Active]	<i>V C t r L</i>	Vortex control is active

[Application State] A P P S

Application state.

This parameter indicates the drive application state.

Setting	Code / Value	Description
[Running]	<i>r u n</i>	No application function in progress; the drive is running
[Stop]	<i>S t o P</i>	No application function in progress; the drive is not running
[Local Mode Active]	<i>L o C A L</i>	Forced local mode activated
[Channel 2 Active]	<i>o V E r</i>	Override speed control mode activated
[Manual Mode Active]	<i>M A N U</i>	Motor running; manual PID mode is active
[PID Active]	<i>A U T O</i>	Motor running; auto PID mode is active
[Antijam In Progress]	<i>A J A M</i>	The Anti-jam is in progress
[Flow Limit In Progress]	<i>F L , M</i>	The flow limitation is in progress
[PipeFill In Progress]	<i>F , L L</i>	The pipe fill is in progress
[Jockey Pump Active]	<i>J o C K E Y</i>	The jockey pump is active
[Boost In progress]	<i>b o o S t</i>	The boost is in progress
[Sleep Active]	<i>S L E E P</i>	The sleep is active
[Priming Pump Active]	<i>P r , M</i>	The priming pump is active
[InletPres Comp In Progress]	<i>C o M P</i>	The inlet pressure compensation is in progress
[VxCtrl Learning]	<i>V L E A r n</i>	Vortex control learning is in progress
[VxCtrl Active]	<i>V C t r L</i>	Vortex control is active

[Booster Status] b C S ★

Booster status.

This parameter can be accessed if **[Application Selection] R P P L** is set to **[Pump Booster Control] b o o S t** and **[Booster Control]** is set to **[Yes] Y E S**.

Setting	Code / Value	Description
[None]	<i>n o n E</i>	Not configured
[Inactive]	<i>n A c t</i>	Inactive
[Running]	<i>r u n</i>	Running
[Stage Pending]	<i>S t G P</i>	Stage pending
[Destage Pending]	<i>d S t G P</i>	Destage pending
[Staging]	<i>S t G</i>	Staging in progress
[Destaging]	<i>d S t G</i>	Destage in progress

[LevelCtrl Status] L C 5 ★

Level control status.

This parameter can be accessed if **[Application Selection] R P P L** is set to **[Pump Level Control] L E V E L** and **[LevelCtrl Mode] L C M** is not set to **[No] n o**.

Setting	Code / Value	Description
[None]	n o n E	Not configured
[Inactive]	n A c t	Inactive
[Filling]	F i l l	Filling in progress
[Emptying]	E m p t y	Emptying in progress
[Low Level]	L o w	Low level
[High Level]	h i g h	High level

[Tank Level] L C 6 L ★

Tank level.

This parameter can be accessed if **[Application Selection] R P P L** is set to **[Pump Level Control] L E V E L** and **[LevelCtrl Mode] L C M** is not set to **[No] n o**.

Setting	Description
0.0...100.0%	Setting range Factory setting: –

[PID Reference] r P C ★

PID reference.

This parameter can be accessed if **[PID Feedback] P i F** is not set to **[Not Configured] n o**.

Setting	Description
0...65,535%	Setting range Factory setting: –

[PID Feedback] r P F ★

PID feedback.

This parameter can be accessed if **[PID Feedback] P i F** is not set to **[Not Configured] n o**.

Setting	Description
0...65,535%	Setting range Factory setting: –

[Outlet Pressure] P 5 2 U

Outlet pressure value.

This parameter can be accessed if **[OutletPres Assign] P 5 2 R** is not set to **[Not Configured] n o.**

Setting	Description
-32,767...32,767	Setting range according to [P sensor unit] S U P r Factory setting: -

[Inlet Press. Value] P 5 1 U

Inlet pressure value.

This parameter can be accessed if **[InletPres Assign] P 5 1 R** is not set to **[Not Configured] n o.**

Setting	Description
-32,767...32,767	Setting range according to [P sensor unit] S U P r Factory setting: -

[Installation Flow] F 5 1 U

Flow rate sensor value.

This parameter can be accessed if **[Inst. Flow Assign.] F 5 1 R** is not set to **[Not Configured] n o.**

Setting	Description
-32,767...32,767	Setting range according to [Flow rate unit] S U F r Factory setting: -

[Flow Estimated] S L F V ★

Estimated flow value.

This parameter can be accessed if **[Flow Estimation Mode] F E M** is not set to **[No] n o.**

Setting	Description
-32,767...32,767	Setting range according to [Flow rate unit] S U F r Factory setting: -

[Control] F E r - Menu

Access

[Dashboard] → [Control]

About This Menu

This menu can be accessed if **[Application Selection] R P P L** is set to **[Generic Fan Control] F R n**.

[PID Reference] r P L ★

PID reference.

This parameter can be accessed if **[PID Feedback] P , F** is not set to **[Not Configured] n o**.

Setting	Description
0...65,535%	Setting range Factory setting: –

[PID Feedback] r P F ★

PID feedback.

This parameter can be accessed if **[PID Feedback] P , F** is not set to **[Not Configured] n o**.

Setting	Description
0...65,535%	Setting range Factory setting: –

[Dashboard] d S H - Menu

Access

[Dashboard]

About This Menu

Using **F4** function key on the Graphic Display Terminal, it is possible to select one of the following view for the **[Control]** tab.

[PID Feedback Trend] P F t

Displays the instantaneous PID controller feedback curve.

[Outlet Pressure Trend] o P t

Displays the instantaneous outlet pressure curve.

[Inlet Pressure Trend] i P t

Displays the instantaneous inlet pressure curve.

[Installation Flow Trend] i F t

Displays the instantaneous installation flow curve.

[kWh Counters] K W C - menu

Access

[Dashboard] → [kWh Counters]

About This Menu

This menu presents many energy objects available for instantaneous data and kW consumption reports.

It offers the possibility to display logged data with graphics by pressing the F4 function key.

[Elc Energy Cons] o C 4★

Electrical energy consumed by the motor in TWh.

This parameter can be accessed if **[Elc energy cons(TWh)] o C 4** is not set to 0.

Setting	Description
0...999 TWh	Setting range Factory setting: Read Only

[Elc Energy Cons] o C 3★

Electrical energy consumed by the motor in GWh.

Setting	Description
0...999 GWh	Setting range Factory setting: Read Only

[Elc Energy Cons] o C 2★

Electrical energy consumed by the motor in MWh.

Setting	Description
0...999 MWh	Setting range Factory setting: Read Only

[Elc Energy Cons] o C 1★

Electrical energy consumed by the motor in kWh.

Setting	Description
0...999 kWh	Setting range Factory setting: Read Only

[Elc Energy Cons] □ [D]★

Electrical energy consumed by the motor in Wh.

Setting	Description
0...999 Wh	Setting range Factory setting: Read Only

[Acv Elc Out Pwr Estm] E P r W

Active electrical output power estimation.

Setting	Description
-32,767...32,767	Setting range Value in kW or HP according to [Motor Standard] b F r setting Factory setting: Read Only

[Elc Egy Today] □ [t]

Electrical energy consumed today by the motor in kWh.

Setting	Description
0...4,294,967,295 kWh	Setting range in kWh Factory setting: Read Only

[Elc Egy Yesterday] □ [Y]

Electrical energy consumed yesterday by the motor in kWh.

Setting	Description
0...4,294,967,295 kWh	Setting range in kWh Factory setting: Read Only

[Dashboard] d S H - Menu

Access

[Dashboard]

About This Menu

Using **F4** function key on the Graphic Display Terminal, it is possible to select one of the following view for the **[Energy]** tab.

[Instant kW Trend] C V I

Displays the instantaneous electrical energy curve at the drive output.

[Daily kWh Report] H S d

Displays the daily energy histogram.

[Weekly kWh Report] H S W

Displays the weekly energy histogram.

[Monthly kWh Report] H S M

Displays the monthly energy histogram.

[Yearly kWh Report] H S Y

Displays the yearly energy histogram.

[Diagnostics] *d* , *A* -

What's in This Chapter

[Diag. data]	74
[Error history] <i>P F H</i> - Menu	76
[Warnings] <i>A L r</i> - Menu	78

Introduction



[Diagnostics] *d* , *A* - menu presents drive and application data useful when diagnostics is required.

[Diag. data]

[Diag. data] *d d t* - Menu

Access

[Diagnostics] → [Diag. data]

About This Menu

This menu presents the last warning and detected error in addition to drive data.

[Last Warning] *L R L r*

Last warning which occurred.

The list of warning codes is available in the chapter Warning Codes, page 620.

[Last Error] *L F t*

Last error which occurred.

The list of error codes is available in the chapter Error Codes, page 623.

[Identification Error] *in F t* ★

Identification Error (inF6).

This parameter can be accessed if [Last Error] *L F t* is [Identification Error] *in F t* in order to provide more information on the related error.

Setting	Description
0...12 (value in Hex.)	0x00 : No error detected 0x01 : No response of the option module 0x02 : Signature reception timeout 0x03 : ACK reception timeout 0x04 : Signature length 0x05 : CheckSum 0x06 : Unknown state 0x07 : UART receive 0x08 : Unknown protocol version 0x09 : Unknown module type 0x0A : More than 5 unsuccessful tries 0x0B : Unknown module type 0x0C : Option module not supported by the slot 0x0D : Same option module in more than one slot 0x0E : O1SV not received 0x0F : O1SV option module software version not compatible 0x10 : reserved 0x11 : reserved 0x12 : Control terminal module not present or not recognized Factory setting: Read-only parameter

[Nb Of Start] *n S n*

Number of motor starts (resettable).

Setting	Description
0...4,294,967,295	Setting range Factory setting: —

[Motor Run Time] r t H H

Motor run time.

Run elapsed time display (resettable) in 0.1 hours (length of time the motor has been switched on).

Setting	Description
0.0...119,304.5 h	Setting range Factory setting: _

[Service message] 5 E r - menu

This menu presents the service message.

This service message is defined using **[My preferences] n y P -** → **[Customization] C u 5 -** → **[Service messages] 5 E r - menu**.

[Other State] 5 5 t - menu

This menu shows the list of present secondary states.

For more information refer to **[Display] n o n -** → **[Other state] 5 5 t -**.

[Diagnostics] d R u - menu

This menu allows to make simple test sequences for diagnostics such as Fan(s), HMI LED(s) and IGBT(s) diagnostics.

For more information refer to **[Complete setting] C 5 t -** → **[Maintenance] C 5 n R -** → **[Diagnostics] d R u -**.

[Identification] o i d - menu

This is a read-only menu that cannot be configured. It enables the following information to be displayed:

- Drive reference, power rating, and voltage
- Drive software version
- Drive serial number
- Type of option modules present, with their software version
- Graphic Display Terminal type and version.

[Error history] P F H - Menu

[Error history] P F H - Menu

Access

[Diagnostics] → [Error history]

About This Menu

This menu shows the 15 last detected errors ([Last Error 1] d P I to [Last Error 15] d P F). [Last Error 1] d P I is the last stored error.

With the Graphic Display Terminal, the date and time, at which the error has been triggered, is displayed in this menu. The date and time could be set through the [Date/time settings] r E C , page 605

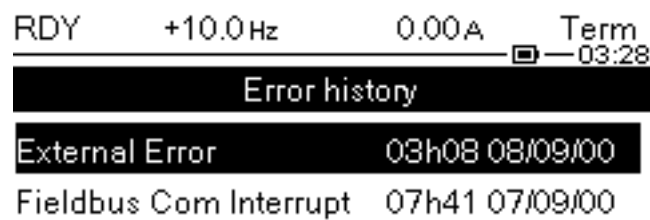

NOTE: The list of error codes is available in the chapter "Diagnostics and Troubleshooting" , page 623.

NOTE: If [Auto fault reset] R E r is active, a triggered error is not stored in the error history until the attempts to perform the Fault Reset end unsuccessful.

Pressing OK key on the selected error code in the error history list displays the drive data recorded when the error has been detected.

NOTE: Pressing F1 on the Graphic Display Terminal can give more information about the selected error.

The below table shows the list of drive data recorded for each detected error (these are read-only parameters).

Parameter	Code	Description	Related to the parameter...
[Device State]	H 5 I ... H 5 F	HMI Status.	[Device State] H Π , 5
[Last Error x Status]	E P I ... E P F	ETA state word: status of last error x. DRIVECOM status register displayed in hexadecimal	[CIA402 State Reg] E E R
[ETI state word]	, P I ... , P F	ETI state word (displayed in hexadecimal). NOTE: [Internal State Reg] E E , can be accessed using fieldbus communication.	[Internal State Reg] E E ,
[Cmd word]	C Π P I ... C Π P F	Cmd word (displayed in hexadecimal).	[Cmd Register] C Π d

[Motor Current]	L C P I... L C P F	Motor current (unit is similar to [Motor Current] L C r)	[Motor Current] L C r
[Output frequency]	r F P I... r F P F	Output frequency (estimated signed value in 0.1 Hz).	[Output frequency] r F r
[Elapsed time]	r t P I... r t P F	Elapsed time (value in hours).	[Motor Run Time] r t H H
[DC bus voltage]	v L P I... v L P F	DC bus voltage (value in 0.1 V) NOTE: [No meas.] v L n u n K is displayed if no value is measured.	[DC bus voltage] v b u 5
[Motor Therm State]	t H P I... t H P F	Motor thermal state.	[Motor Therm State] t H r
[Command Channel]	d C C I... d C C F	Command channel. NOTE: The command channel can be different from the reference frequency channel in separated mode.n	[Command Channel] C n d C
[Ref Freq Channel]	d r C I... d r C F	Channel for reference frequency.	[Ref Freq Channel] r F C C
[Motor Torque]	o t P I... o t P F	Motor torque (estimated value in 0.1 % of [Nom Motor Torque] t q n). NOTE: The displayed value is always positive in motor mode and negative in generator mode whatever the direction.	[Motor Torque] o t r
[Drive Thermal State]	t d P I... t d P F	Drive thermal state (measured).	[Drive Thermal State] t H d
[IGBT Junction Temp]	t J P I... t J P F	IGBT junction temperature (estimated value in 1 °C).	Not applicable
[Switching Frequency]	S F P I... S F P F	Switching Frequency (value in 1 Hz).	[Switching Frequency] S F r
[Power Brick Error ID]	b P , I... b P , F	Power Brick error ID. This parameter can only be accessed on ATV•60, ATV•80 and ATV•B0. The value displayed is the bit number of the brick currently in error, starting with number 1 on the right side (e.g. bit0 = brick 1, bit3 = brick 4).	Not applicable
[AFE Power brick error ID]	b F , I... b F , F	Active Front End brick error ID. This parameter can only be accessed on ATV•60, ATV•80 and ATV•B0. The value displayed is the bit number of the brick currently in error, starting with number 1 on the right side (e.g. bit0 = brick 1, bit3 = brick 4).	Not applicable

[Warnings] R L r - Menu

[Actual warnings] R L r d - Menu

Access

[Diagnostics] → [Warnings] → [Actual warnings]

About This Menu

List of current warnings.

If a warning is active, ✓ and  appears on the Graphic Display Terminal.

List of Available Warnings

The list of warning codes is available in the chapter Diagnostics and Troubleshooting, page 619.

[Warning group 1 definition] R I C - to [Warning group 5 definition] R S C - Menus

Access

[Diagnostics] → [Warnings] → [Warning group 1 definition] to [Warning group 5 definition]

About This Menu

The following submenus group the warnings into 1 to 5 groups, each of which can be assigned to a relay or a digital output for remote signaling.

When one or a number of warnings selected in a group occurs, this warning group is activated.

List of Warnings

The list of warning codes is available in the chapter Diagnostics and Troubleshooting, page 619.

[Warnings] R L r - Menu

Access

[Diagnostics] → [Warnings]

About This Menu

This menu presents the warning history (30 past warnings).

[Warning History] *R L H*

Identical to [Last warning] *L R L r* .
, page 74

[Display] Π ο η -

What's in This Chapter

[Energy parameters].....	81
[Application parameters].....	90
[Pump parameters].....	95
[Motor parameters].....	107
[Drive parameters].....	110
[Thermal monitoring].....	114
[PID display].....	115
[Counter management].....	117
[Other state].....	120
[I/O map].....	121
[Communication map].....	124
[Data logging].....	129

Introduction



[Display] Π ο η - menu shows monitoring data related to the drive and the application.

This menu is accessible if [Access level] *L A C* is set to a different value than [Basic] *b A 5*.

It offers an application-oriented display in terms of energy, cost, cycle, efficiency, ...

This is available with customized units and graphics view.

[Energy parameters]

[Elec Ener Input Counter] $E L \ , -$ Menu

Access

[Display] → [Energy parameters] → [Elec Ener Input Counter]

About This Menu

This menu presents the input electrical energy data.

NOTE: On Altivar Process range, except for ATV680 and ATV6B0 products, the power and energy parameters are estimated based on the output current of the drive. For ATV680 and ATV6B0 products, the power and energy parameters are measured.

[Active Input Power] $\ , P r W$

Active electrical input power.

Setting	Description
According to the drive rating	Setting range in kW if [Motor Standard] $b F r$ is set to [50Hz IEC] $5 D$ or in HP if [Motor Standard] $b F r$ is set to [60Hz NEMA] $5 D$ Factory setting: _

[Input Reactive Power] $\ , q r W$

Reactive electrical input power.

This parameter can be accessed on ATV680 and ATV6B0

Setting	Description
According to the drive rating	Setting range in kW if [Motor Standard] $b F r$ is set to [50Hz IEC] $5 D$ or in HP if [Motor Standard] $b F r$ is set to [60Hz NEMA] $5 D$ Factory setting: _

[Input Power Factor] $P W F$

Mains input power factor.

This parameter can be accessed on ATV680 and ATV6B0

Setting	Description
According to the drive rating	Setting range displayed as a percentage Factory setting: _

[Real Input Energy] $\ , E 4 \star$

Input electrical power consumed (TWh).

This parameter can be accessed if [Real Input Energy] $\ , E 4$ is not set to 0.

Setting	Description
-999...999 TWh	Setting range Factory setting: _

[Real Input Energy] , E 3★

Input electrical power consumed (GWh).

Setting	Description
-999...999 GWh	Setting range Factory setting: _

[Real Input Energy] , E 2★

Input electrical power consumed (MWh).

Setting	Description
-999...999 MWh	Setting range Factory setting: _

[Real Input Energy] , E 1★

Input electrical power consumed (kWh).

Setting	Description
-999...999 kWh	Setting range Factory setting: _

[Real Input Energy] , E 0★

Input electrical power consumed (Wh).

Setting	Description
-999...999 Wh	Setting range Factory setting: _

[Elec Ener Output Counter] $E L \square -$ Menu

Access

[Display] → [Energy parameters] → [Elec Ener Output Counter]

About This Menu

This menu presents the output electrical energy data.

[Acv Elc out pwr estm] $E P r W$

Active electrical output power estimation.

Setting	Description
According to the drive rating	Setting range in kW if [Motor Standard] b F r is set to [50Hz IEC] 5 D or in HP if [Motor Standard] b F r is set to [60Hz NEMA] 6 D Factory setting: _

[Real Consumption] $\square E 4 \star$

Electrical energy consumed (TWh).

This parameter can be accessed if **[Real Consumption] $\square E 4$** is not set to 0.

Setting	Description
-999...999 TWh	Setting range Factory setting: _

[Real Consumption] $\square E 3$

Electrical energy consumed (GWh).

Setting	Description
-999...999 GWh	Setting range Factory setting: _

[Real Consumption] $\square E 2$

Electrical energy consumed (MWh).

Setting	Description
-999...999 MWh	Setting range Factory setting: _

[Real Consumption] $\square E 1$

Electrical energy consumed (kWh).

Setting	Description
-999...999 kWh	Setting range Factory setting: _

[Real Consumption] α E D

Electrical energy consumed (Wh).

Setting	Description
-999...999 Wh	Setting range Factory setting: _

[Elc Egy Today] α C E

Electrical energy consumed today by the motor (kWh).

Setting	Description
0...4,294,967,295 kWh	Setting range Factory setting: _

[Elc Egy Yesterday] α C Y

Electrical energy consumed yesterday by the motor (kWh).

Setting	Description
0...4,294,967,295 kWh	Setting range Factory setting: _

[Over-Consumption Thd] P C R H

Power level for over-consumption.

Setting	Description
[Under-Consumption Thd] P C R L ...200.0%	Setting range Factory setting: 0.0%

[Under-Consumption Thd] P C R L

Power level for under-consumption.

Maximum value = P C R H if P C R H \leq 100%.

Setting	Description
0.0...100.0% or [Over-Consumption Thd] P C R H if P C R H \leq 100%	Setting range Factory setting: 0.0%

[Over/Under-Cons Delay] $P \square R \square$

Over/under-consumption detection time.

Setting	Description
0...60 min	Setting range Factory setting: 1 min

[Peak Output Power] $\Pi \square E P$

Peak output power.

Setting	Description
According to the drive rating	Setting range Factory setting: _

[Mechanical energy] $\Pi E C$ - Menu

Access

[Display] → [Energy parameters] → [Mechanical energy]

About This Menu

This menu presents the output mechanical energy data.

[Power Estim Value] $\sigma P r W$

Motor shaft power estimation.

Setting	Description
According to the drive rating	Setting range in kW if [Motor Standard] $b F r$ is set to [50Hz IEC] $5 D$ or in HP if [Motor Standard] $b F r$ is set to [60Hz NEMA] $6 D$ Factory setting: _

[Motor Consumption] $\Pi E 4$ ★

Energy consumption (TWh).

This parameter can be accessed if [Motor Consumption] $\Pi E 4$ is not set to 0.

Setting	Description
0...999 TWh	Setting range Factory setting: _

[Motor Consumption] $\Pi E 3$ ★

Energy consumption (GWh).

Setting	Description
0...999 GWh	Setting range Factory setting: _

[Motor Consumption] $\Pi E 2$ ★

Energy consumption (MWh).

Setting	Description
0...999 MWh	Setting range Factory setting: _

[Motor Consumption] $\Pi E 1$ ★

Energy consumption (kWh).

Setting	Description
0...999 kWh	Setting range Factory setting: _

[Motor Consumption] Π Ε Ω★

Energy consumption (Wh).

Setting	Description
0...999 Wh	Setting range Factory setting: _

[Energy saving] *E S R* - Menu

Access

[Display] → [Energy parameters] → [Energy saving]

About This Menu

This menu presents the comparison in term of cost, energy, CO₂ between solutions with and without drive.

[Reference Power] *P r E F*

Reference Power without drive

Setting	Description
0.00...655.35 kW	Setting range in kW if [Motor Standard] <i>b F r</i> is set to [50Hz IEC] <i>S D</i> or in HP if [Motor Standard] <i>b F r</i> is set to [60Hz NEMA] <i>E D</i> . Factory setting: 0.00 kW

[kWh Cost] *E C S E*

Cost of the kWh.

Setting	Description
0.00...655.35 \$	Setting range in € if [Motor Standard] <i>b F r</i> is set to [50 Hz IEC] <i>S D</i> or in \$ if [Motor Standard] <i>b F r</i> is set to [60Hz NEMA] <i>E D</i> . Factory setting: _

[CO2 Ratio] *E C o 2*

Quantity of CO₂ by kWh.

Setting	Description
0.000...65.535 kg/kWh	Setting range Factory setting: 0.000 kg/kWh

[Energy Saved] *E S R V*

Energy saved with the drive solution.

Setting	Description
0...4,294,967,295 kWh	Setting range Factory setting: _

[Money Saved] *C A S H*

Cost saved with the drive solution.

Setting	Description
0.00...42,949,672 \$	Setting range in € if [Motor Standard] b F r is set to [50 Hz IEC] S D or in \$ if [Motor Standard] b F r is set to [60 Hz NEMA] S D . Factory setting: _

[Co2 Saved] Γ σ ρ ζ ξ

CO₂ saved with the drive solution.

Setting	Description
0.0...429,496,729.5 t	Setting range Factory setting: _

[Application parameters]

[Application parameters] *APP* - Menu

Access

[Display] → [Application parameters]

About This Menu

This menu displays information related to the application.

[System App State] *APP55*

System application state

This parameter indicates the installation application state

This parameter can be accessed if **[Pump System Archi]** *PP5A* is set to **[Multi Drives]** *nV5d* or **[Multi Masters]** *nV5dr*

Setting	Code / Value	Description
[Running]	<i>run</i>	No application function in progress; the drive is running
[Stop]	<i>Stop</i>	No application function in progress; the drive is not running
[Manual Mode Active]	<i>MANU</i>	Motor running; manual PID mode is active
[PID Active]	<i>AUTO</i>	Motor running; auto PID mode is active
[Flow Limit In Progress]	<i>FLI</i>	The flow limitation is in progress
[PipeFill In Progress]	<i>FLI</i>	The pipe fill is in progress
[Jockey Pump Active]	<i>JOCKEY</i>	The jockey pump is active
[Boost In progress]	<i>BOOST</i>	The boost is in progress
[Sleep Active]	<i>SLEEP</i>	The sleep is active
[Priming Pump Active]	<i>PRIM</i>	The priming pump is active
[InletPres Comp In Progress]	<i>COMP</i>	The inlet pressure compensation is in progress

[Application State] *APP5*

Application state.

This parameter indicates the drive application state.

Setting	Code / Value	Description
[Running]	<i>run</i>	No application function in progress; the drive is running
[Stop]	<i>Stop</i>	No application function in progress; the drive is not running
[Local Mode Active]	<i>LOCAL</i>	Forced local mode activated

Setting	Code / Value	Description
[Channel 2 Active]	ο V E r	Override speed control mode activated
[Manual Mode Active]	Π Α ν υ	Motor running; manual PID mode is active
[PID Active]	Α υ τ ο	Motor running; auto PID mode is active
[Antijam In Progress]	Α J Α Π	The Anti-jam is in progress
[Flow Limit In Progress]	F L , Π	The flow limitation is in progress
[PipeFill In Progress]	F , L L	The pipe fill is in progress
[Jockey Pump Active]	J ο C K E Y	The jockey pump is active
[Boost In progress]	b ο ο S t	The boost is in progress
[Sleep Active]	S L E E P	The sleep is active
[Priming Pump Active]	P r , Π	The priming pump is active
[InletPres Comp In Progress]	Ε ο Π P	The inlet pressure compensation is in progress

[Booster Status] β C 5 ★

Booster status.

This parameter can be accessed if **[Application Selection] Α P P L** is set to **[Pump Booster Control] b ο ο S t**.

Setting	Code / Value	Description
[None]	n ο ο E	Not configured
[Inactive]	n Α c t	Inactive
[Running]	r υ ν	Running
[Stage Pending]	S t G P	Stage pending
[Destage Pending]	d S t G P	Destage pending
[Staging]	S t G	Staging in progress
[Destaging]	d S t G	Destage in progress

[LevelCtrl Status] L C 5 ★

Level control status.

This parameter can be accessed if **[Application Selection] Α P P L** is set to **[Pump Level Control] L E V E L**.

Setting	Code / Value	Description
[None]	n ο ο E	Not configured
[Inactive]	n Α c t	Inactive
[Filling]	F , L L	Filling in progress
[Emptying]	Ε Π P t Y	Emptying in progress

Setting	Code / Value	Description
[Low Level]	<i>L o w</i>	Low level
[High Level]	<i>h i g h</i>	High level

[Tank Level] *L C E L* ★

Tank level.

This parameter can be accessed if **[Application Selection]** *R P P E* is set to **[Pump Level Control]** *L E V E L*.

Setting	Description
0.0...100.0%	Setting range Factory setting: –

[Level Sensor Value] *L C S V* ★

Level sensor value.

This parameter can be accessed if **[Level Sensor Assign]** *L c S R* is not set to **[Not configured]** *n o*.

Setting	Description
-327.67...327.67	Setting range Factory setting: –

[Level Sensor Value] *L C F V*

Filtered Level Sensor Value.

This parameter can be accessed if **[Application Selection]** *R P P E* is set to **[Pump Level Control]** *L E V E L* and **[LevelCtrl Mode]** *L C M* set to a value different than **[No]** *n o*.

Setting	Description
-327.67...327.67	Setting range Factory setting: –

[PID Reference] *r P C* ★

PID reference.

This parameter can be accessed if **[PID Feedback]** *P i F* is not set to **[Not Configured]** *n o*.

Setting	Description
0...65,535%	Setting range Factory setting: –

[PID feedback] *r P F* ★

PID feedback.

This parameter can be accessed if **[PID Feedback] P 1 F** is not set to **[Not Configured] n o .**

Setting	Description
0...65,535%	Setting range Factory setting: –

[Installation Flow] F 5 1 V

Flow rate sensor value.

This parameter can be accessed if **[Inst. Flow Assign.] F 5 1 R** is not set to **[Not Configured] n o .**

Setting	Description
-32,767...32,767	Setting range according to [Flow rate unit] S u F r Factory setting: –

[Inlet Press. Value] P 5 1 V

Inlet pressure value.

This parameter can be accessed if **[InletPres Assign] P 5 1 R** is not set to **[Not Configured] n o .**

Setting	Description
-32,767...32,767	Setting range according to [P sensor unit] S u P r Factory setting: –

[Outlet Pressure] P 5 2 V

Outlet pressure value.

This parameter can be accessed if **[OutletPres Assign] P 5 2 R** is not set to **[Not Configured] n o .**

Setting	Description
-32,767...32,767	Setting range according to [P sensor unit] S u P r Factory setting: –

[Total Quantity] F 5 1 C

Total quantity.

This parameter can be accessed if **[Inst. Flow Assign.] F 5 1 R** is not set to **[Not Configured] n o .**

Setting	Description
-2,147,483,647...2,147,483,647	Setting range according to [Flow rate unit] S u F r Factory setting: –

[Highest Flow] F 5 I K

Highest flow.

This parameter can be accessed if **[Inst. Flow Assign.] F 5 I A** is not set to **[Not Configured] n o .**

Setting	Description
-32,767...32,767	Setting range according to [Flow rate unit] S u F r Factory setting: –

[Lowest Flow] F 5 I J

Lowest flow.

This parameter can be accessed if **[Inst. Flow Assign.] F 5 I A** is not set to **[Not Configured] n o .**

Setting	Description
-32,767...32,767	Setting range according to [Flow rate unit] S u F r Factory setting: –

[Pump parameters]

[Variable speed pump] $\Pi P P -$ Menu

Access

[Display] → [Pump parameters] → [Variable speed pump]

About This Menu

This menu shows the pump-related parameters.

[Motor Run Time] $r \text{ t H H}$

Motor run time.

Run elapsed time display (resettable) in 0.1 hours (length of time the motor has been switched on).

Setting	Description
0.0...119,304.5 h	Setting range Factory setting: _

[Motor Mechanical speed] $S P \text{ d } \Pi$

Motor mechanical speed.

This parameter displays the estimated rotor speed with motor slip.

Setting	Description
0...65,535 rpm	Setting range Factory setting: _

[Nb Of Start] $\Pi S \Pi$

Number of motor starts (resettable).

Setting	Description
0...4,294,967,295	Setting range Factory setting: _

[Acv Elc Out Pwr Estm] $E P r W$

Active electrical output power estimation.

Setting	Description
-327.67...327.67 kW	Setting range in kW if [Motor Standard] $b F r$ is set to [50 Hz IEC] $S D$ or in HP if [Motor Standard] $b F r$ is set to [60 Hz NEMA] $S D$ Factory setting: _

[Pump Flow] F 5 2 V ★

Pump flow value.

This parameter can be accessed if **[Pump Flow Assign.] F 5 2 R** is not set to **[Not Configured] $\Pi \square$** .

Setting	Description
-32,767...32,767	Setting range according to [Flow rate unit] S u F r . Factory setting: -

[Flow Estimated] S L F V ★

Estimated flow value.

This parameter can be accessed if **[Flow Estimation Mode] F E Π** is not set to **[No] $\Pi \square$** .

Setting	Description
-32,767...32,767	Setting range according to [Flow rate unit] S u F r . Factory setting: -

[Inlet Press. Value] P 5 1 V ★

Inlet pressure value.

This parameter can be accessed if **[InletPres Assign] P 5 1 R** is not set to **[Not Configured] $\Pi \square$** .

Setting	Description
-32,767...32,767	Setting range according to [P sensor unit] S u P r . Factory setting: -

[Outlet Pressure] P 5 2 V ★

Outlet pressure.

This parameter can be accessed if **[OutletPres Assign] P 5 2 R** is not set to **[Not Configured] $\Pi \square$** .

Setting	Description
-32,767...32,767	Setting range according to [P sensor unit] S u P r . Factory setting: -

[Est. Pump Head] S L H V ★

Estimated Pump head value

This parameter can be accessed if **[OutletPres Assign] P 5 2 R** is not set to **[Not Configured] $\Pi \square$** .

Setting	Description
-32,767...32,767	Setting range according to [P sensor unit] S u P r . Factory setting: -

[Est. Pump dP] $S L d P \star$

Estimated Pump delta pressure value

This parameter can be accessed if **[OutletPres Assign] $P S Z R$** is not set to **[Not Configured] $n \sigma$** .

Setting	Description
-32,767...32,767	Setting range according to [P sensor unit] $S \sigma P r$ Factory setting: –

[Efficiency] $E F Y$

The efficiency is based on mechanical power.

Setting	Description
0.0...100.0 %	Setting range Factory setting: _

[Energy Cons. Ind.] $E C ,$

Energy consumption indication is based on the consumption of the electrical power

Setting	Description
-32,767...32,767	Setting range Factory setting: –

[Energy Perf. Ind] $E P ,$

Energy performance indicator is based on the electrical power

Setting	Description
-32,767...32,767	Setting range Factory setting: –

[Highest Eff.] $E F Y K$

Highest efficiency.

Setting	Description
0.0...100.0 %	Setting range Factory setting: _

[Lowest Eff.] $E F Y J$

Lowest efficiency.

Setting	Description
0.0...100.0 %	Setting range Factory setting: _

[Multipump system] $\Pi P S -$ Menu

Access

[Display] → [Pump parameters] → [Multipump system]

About This Menu

This menu can be accessed if [Pump System Archit] $\Pi P S A$ is not set to [No] $\eta \sigma$.

[MultiPump State] $\Pi P S$

Multipump function state.

Setting	Code / Value	Description
[None]	$\eta \sigma \eta E$	None
[Ready]	$r E A d Y$	Ready
[Running]	$r u n$	Running
[Warning]	$A L A r \Pi$	Warning
[Error]	$F A u L t$	Error
[Not Available]	$\eta A V L$	Not available

[Active Master ID] $\Pi \Pi , d$

Active master ID.

This parameter can be accessed if [Pump System Archi] $\Pi P S A$ is set to [Multi Masters] $\eta V S d r$.

Setting	Code / Value	Description
[None]	$\eta \sigma \eta E$	No pump active.
[Pump 1]	$P D 1$	Pump 1.
[Pump 2]	$P D 2$	Pump 2.
[Pump 3]	$P D 3$	Pump 3.
[Pump 4]	$P D 4$	Pump 4.
[Pump 5]	$P D 5$	Pump 5.
[Pump 6]	$P D 6$	Pump 6.

[Available Pumps] $\Pi P A \eta$

Number of available pumps.

Setting	Description
0...65,535	Setting range Factory setting: –

[Nb of Staged Pumps] $\Pi P 5 n$

Number of staged pumps.

Setting	Description
0...65,535	Setting range Factory setting: –

[Lead Pump] $P L i d$

Lead pump.

Setting	Code / Value	Description
[None]	$n o n E$	None
[Pump 1]	$P 0 1$	Pump number 1
[Pump 2]	$P 0 2$	Pump number 2
[Pump 3]	$P 0 3$	Pump number 3
[Pump 4]	$P 0 4$	Pump number 4
[Pump 5]	$P 0 5$	Pump number 5
[Pump 6]	$P 0 6$	Pump number 6

[Next Staged Pump] $P n t 5$

Next pump to stage.

Identical to **[Lead Pump] $P L i d$** , page 100.

[Next Destaged Pump] $P n t d$

Next pump to destage.

Identical to **[Lead Pump] $P L i d$** , page 100.

[Pump 1 State] $P 1 5 \star$

Pump 1 state.

This parameter can be accessed if **[Nb Of Pumps] $\Pi P P n$** or **[Nb of Devices] $\Pi P G n$** is set to 1 or higher.

Setting	Code / Value	Description
[None]	$n o n E$	Not configured
[Not Available]	$n A v L$	Unavailable
[Ready]	$r d y$	Ready
[Running]	$r u n$	Running

[Pump 1 Type] $P 1 t \star$

Pump 1 type.

This parameter can be accessed if **[Nb Of Pumps]** $\Pi P P n$ or **[Nb of Devices]** $\Pi P G n$ is set to 1 or higher.

Setting	Code / Value	Description
[None]	$n o n E$	Undefined
[Lead]	$L E A d$	Lead pump
[Lead or Auxiliary]	$L A F$	Lead or auxiliary fixed speed pump
[Lead or Auxiliary Variable]	$L A V$	Lead or auxiliary variable speed pump
[Auxiliary]	$A u X F$	Auxiliary fixed speed pump
[Auxiliary Variable]	$A u X V$	Auxiliary variable speed pump
[Error]	$E r r$	Error

[Pump 1 Runtime] $P 1 o t$ ★

Pump 1 running time.

This parameter can be accessed if **[Nb Of Pumps]** $\Pi P P n$ or **[Nb of Devices]** $\Pi P G n$ is set to 1 or higher.

Setting	Description
0...4,294,967,295 s	Setting range Factory setting: –

[Pump 1 Nb Starts] $P 1 n S$ ★

Pump 1 number of starts.

This parameter can be accessed if **[Nb Of Pumps]** $\Pi P P n$ or **[Nb of Devices]** $\Pi P G n$ is set to 1 or higher.

Setting	Description
0...4,294,967,295 s	Setting range Factory setting: –

[Pump 2 State] $P 2 S$ ★

Pump 2 state.

This parameter can be accessed if **[Nb Of Pumps]** $\Pi P P n$ or **[Nb of Devices]** $\Pi P G n$ is set to 2 or higher.

Identical to **[Pump 1 State]** $P 1 S$, page 100.

[Pump 2 Type] $P 2 t$ ★

Pump 2 type.

This parameter can be accessed if **[Nb Of Pumps]** $\Pi P P n$ or **[Nb of Devices]** $\Pi P G n$ is set to 2 or higher.

Identical to **[Pump 1 Type]** $P 1 t$, page 100.

[Pump 2 Runtime] P 2 α ε ★

Pump 2 running time.

This parameter can be accessed if **[Nb Of Pumps]** Π P P η or **[Nb of Devices]** Π P Γ η is set to 2 or higher.

Identical to **[Pump 1 Runtime]** P 1 α ε , page 101.

[Pump 2 Nb Starts] P 2 η 5 ★

Pump 2 number of starts.

This parameter can be accessed if **[Nb Of Pumps]** Π P P η or **[Nb of Devices]** Π P Γ η is set to 2 or higher.

Identical to **[Pump 1 Nb Starts]** P 1 η 5 , page 101.

[Pump 3 State] P 3 5 ★

Pump 3 state.

This parameter can be accessed if **[Nb Of Pumps]** Π P P η or **[Nb of Devices]** Π P Γ η is set to 3 or higher.

Identical to **[Pump 1 State]** P 1 5 , page 100.

[Pump 3 Type] P 3 ε ★

Pump 3 type.

This parameter can be accessed if **[Nb Of Pumps]** Π P P η or **[Nb of Devices]** Π P Γ η is set to 3 or higher.

Identical to **[Pump 1 Type]** P 1 ε , page 100.

[Pump 3 Runtime] P 3 α ε ★

Pump 3 running time.

This parameter can be accessed if **[Nb Of Pumps]** Π P P η or **[Nb of Devices]** Π P Γ η is set to 3 or higher.

Identical to **[Pump 1 Runtime]** P 1 α ε , page 101.

[Pump 3 Nb Starts] P 3 η 5 ★

Pump 3 number of starts.

This parameter can be accessed if **[Nb Of Pumps]** Π P P η or **[Nb of Devices]** Π P Γ η is set to 3 or higher.

Identical to **[Pump 1 Nb Starts]** P 1 η 5 , page 101.

[Pump 4 State] P 4 5 ★

Pump 4 state.

This parameter can be accessed if **[Nb Of Pumps]** Π P P η or **[Nb of Devices]** Π P Γ η is set to 4 or higher.

Identical to **[Pump 1 State]** P 1 5 , page 100.

[Pump 4 Type] $P 4 E$ ★

Pump 4 type.

This parameter can be accessed if **[Nb Of Pumps] $\Pi P P n$** or **[Nb of Devices] $\Pi P G n$** is set to 4 or higher.

Identical to **[Pump 1 Type] $P 1 E$** , page 100.

[Pump 4 Runtime] $P 4 o t$ ★

Pump 4 running time.

This parameter can be accessed if **[Nb Of Pumps] $\Pi P P n$** or **[Nb of Devices] $\Pi P G n$** is set to 4 or higher.

Identical to **[Pump 1 Runtime] $P 1 o t$** , page 101.

[Pump 4 Nb Starts] $P 4 n S$ ★

Pump 4 number of starts.

This parameter can be accessed if **[Nb Of Pumps] $\Pi P P n$** or **[Nb of Devices] $\Pi P G n$** is set to 4 or higher.

Identical to **[Pump 1 Nb Starts] $P 1 n S$** , page 101.

[Pump 5 State] $P 5 S$ ★

Pump 5 state.

This parameter can be accessed if **[Nb Of Pumps] $\Pi P P n$** or **[Nb of Devices] $\Pi P G n$** is set to 5 or higher.

Identical to **[Pump 1 State] $P 1 S$** , page 100.

[Pump 5 Type] $P 5 E$ ★

Pump 5 type.

This parameter can be accessed if **[Nb Of Pumps] $\Pi P P n$** or **[Nb of Devices] $\Pi P G n$** is set to 5 or higher.

Identical to **[Pump 1 Type] $P 1 E$** , page 100.

[Pump 5 Runtime] $P 5 o t$ ★

Pump 5 running time.

This parameter can be accessed if **[Nb Of Pumps] $\Pi P P n$** or **[Nb of Devices] $\Pi P G n$** is set to 5 or higher.

Identical to **[Pump 1 Runtime] $P 1 o t$** , page 101.

[Pump 5 Nb Starts] $P 5 n S$ ★

Pump 5 number of starts.

This parameter can be accessed if **[Nb Of Pumps] $\Pi P P n$** or **[Nb of Devices] $\Pi P G n$** is set to 5 or higher.

Identical to **[Pump 1 Nb Starts] $P 1 n S$** , page 101.

[Pump 6 State] $P 6 S$ ★

Pump 6 state.

This parameter can be accessed if **[Nb Of Pumps]** $\Pi P P n$ or **[Nb of Devices]** $\Pi P G n$ is set to 6.

Identical to **[Pump 1 State]** $P 1 S$, page 100.

[Pump 6 Type] $P 6 T$ ★

Pump 6 type.

This parameter can be accessed if **[Nb Of Pumps]** $\Pi P P n$ or **[Nb of Devices]** $\Pi P G n$ is set to 6.

Identical to **[Pump 1 Type]** $P 1 T$, page 100.

[Pump 6 Runtime] $P 6 \sigma T$ ★

Pump 6 running time.

This parameter can be accessed if **[Nb Of Pumps]** $\Pi P P n$ or **[Nb of Devices]** $\Pi P G n$ is set to 6.

Identical to **[Pump 1 Runtime]** $P 1 \sigma T$, page 101.

[Pump 6 Nb Starts] $P 6 n S$ ★

Pump 6 number of starts.

This parameter can be accessed if **[Nb Of Pumps]** $\Pi P P n$ or **[Nb of Devices]** $\Pi P G n$ is set to 6.

Identical to **[Pump 1 Nb Starts]** $P 1 n S$, page 101.

[Installation] $\Pi P V 5 - \text{Menu}$

Access

[Display] → [Pump parameters] → [Installation]

About This Menu

This menu can be accessed if [Pump System Archit] $\Pi P 5 R$ is set to [Multi Drives] $\eta V 5 d$ or [Multi Masters] $\eta V 5 d r$.

[Sys Electrical Power] $E P r 5$

Pump system electrical power

Setting	Description
-327.67...327.67 kW	Setting range in kW if [Motor Standard] $b F r$ is set to [50 Hz IEC] $5 D$ or in HP if [Motor Standard] $b F r$ is set to [60 Hz NEMA] $6 D$. Factory setting: _

[Sys Flow] $5 L F 5$

Pump system flow

Setting	Description
-32,767...32,767	Setting range according to [Flow rate unit] $5 u F r$. Factory setting: –

[Sys Delta Pressure] $5 L d 5$

Pump system delta pressure

Setting	Description
-32,767...32,767	Setting range according to [Flow rate unit] $5 u F r$. Factory setting: –

[Sys Efficiency Ind] $E F Y 5$

Pump system efficiency indicator

Setting	Description
0.0...100.0 %	Setting range Factory setting: –

[Sys Energy Cons Ind] $E C , 5$

Pump system energy consumption indicator

Setting	Description
0...32,767	Setting range Factory setting: –

[Sys Performance Ind] $E P , 5$

Pump system performance indicator

Setting	Description
0...32,767	Setting range Factory setting: –

[Motor parameters]

[Motor parameters] $\Pi \Pi \square -$ Menu

Access

[Display] → [Motor parameters]

About This Menu

This menu shows the motor-related parameters.

The parameters available in this menu are in read-only mode, they cannot be configured.

[Motor Speed] $5 P \square$

Motor speed.

This parameter displays the estimated rotor speed without motor slip.

Setting	Description
0...65,535 rpm	Setting range Factory setting:

[Signed Mech Speed] $5 P \square I$

Signed mechanical speed.

Setting	Description
-100,000...100,000 rpm	Setting range Factory setting: –

[Motor Voltage] $\mu \square P$

Motor voltage.

Setting	Description
0... Nom Motor Voltage $\mu \Pi 5$ (step: 1 V)	Setting range Factory setting: –

[Motor Power] $\square P \square$

Motor power.

Estimated output power in % (100% = nominal motor mechanical power).

Setting	Description
-300...300 % (step: 1 %)	Setting range Factory setting: –

[Nom Motor Torque] $t_{q n}$

Computed nominal motor torque (+/- 2% tolerance).

In case of synchronous motors, this parameter is impacted by a modification of **[Syn. EMF constant] $P H 5$** .

In case of asynchronous motors, this parameter is impacted by a modification of **[Magnetizing Current] $i_d R$** .

According to **[Nom Motor Tq Scaling] $t_{q n C}$** setting, **[Nom Motor torque] $t_{q n}$** parameter displays the value of the optimized torque **[Expert Motor Tq] $t_{q n o}$** or the nameplate torque **[Plate Nom Motor Tq] $t_{q n P}$** .

Setting	Description
0.01...65,535 Nm	Setting range according to drive ratings and [Torque Scaling] $i n r t$ setting. Factory setting: Read only

[Motor Torque] $\sigma t r$

Motor torque.

Output torque value (100% = **[Nom Motor Torque] $t_{q n}$**).

NOTE: The displayed value is always positive in motor mode and negative in generator mode whatever the direction.

Setting	Description
-300.0... 300.0 % (step: 0.1 %)	Setting range Factory setting: Read only

[Motor Torque (Nm)] $\sigma t q n$

Motor torque in Nm.

Output torque value.

NOTE: The displayed value is always positive in motor mode and negative in generator mode whatever the direction.

Setting	Description
-32,767...32,767 Nm	Setting range according to drive ratings and [Torque Scaling] $i n r t$ setting. Factory setting: Read only

[Motor Current] $L C r$

Motor current (estimation).

Setting	Description
0...2 In ⁽¹⁾ (step: 0.01 A ⁽²⁾)	Setting range according to drive ratings Factory setting: –
<p>⁽¹⁾: In corresponds to the rated drive current indicated in the Installation Manual and on the drive nameplate.</p> <p>⁽²⁾: For drives with power range ≤ 15 kW. If the power range is between 18 and 160 kW (limits included), the step is 0.1 A else it is 1 A.</p>	

[Motor Therm state] L H r

Motor thermal state.

The normal motor thermal state is 100 %, the **[Motor Overload] o L F** threshold is set to 118 %.

Setting	Description
0...200 % (step: 1 %)	Setting range Factory setting: –

[Drive parameters]

[Drive parameters] Π Ρ , - Menu

Access

[Display] → [Drive parameters]

About This Menu

This menu shows the drive-related parameters.

[AIV1 Image input] Α , V 1

AIV1 Image input.

This parameter is read-only. It enables to display the speed reference applied to the motor, or the sensor value, via the fieldbus channel.

Setting	Description
-10,000...10,000 ⁽¹⁾	Setting range Factory setting: –
1): range according to [AIV1 Type] Α V 1 Ε .	

[AIV2 Image input] Α , V 2

AIV2 Image input.

This parameter is read-only. It enables to display the speed reference applied to the motor, or the sensor value, via the fieldbus channel.

Setting	Description
-10,000...10,000 ⁽¹⁾	Setting range Factory setting: –
1): range according to [AIV2 Type] Α V 2 Ε .	

[AIV3 Image input] Α , V 3

AIV3 Image input.

This parameter is read-only. It enables to display the speed reference applied to the motor, or the sensor value, via the fieldbus channel.

Setting	Description
-10,000...10,000 ⁽¹⁾	Setting range Factory setting: –
1): range according to [AIV3 Type] Α V 3 Ε .	

[Pre-Ramp Ref Freq] F ρ Η

Frequency reference before ramp.

This parameter is read-only. It enables to display the reference frequency applied to the motor, regardless of which channel for reference value has been selected.

Setting	Description
-500.0...500.0 Hz	Setting range Factory setting: 0 Hz

[Ref Frequency] $L F r$

Reference frequency.

This parameter only appears if the function has been enabled. It is used to change the reference frequency from the remote control. OK does not have to be pressed to enable a change of reference.

Setting 	Description
-500.0...500.0 Hz	Setting range Factory setting: –

[Motor Frequency] $r F r$

Motor frequency.

This parameter displays the estimated rotor frequency without motor slip.

Setting	Description
-3,276.7...3,276.7 Hz	Setting range Factory setting: 0.0 Hz

[Multiplying coeff.] $\Pi F r$

Multiplying coefficient

This parameter can be accessed if [Ref Freq 2 Multiply] $\Pi R 2$ or [Ref Freq 3 Multiply] $\Pi R 3$ are not set to [Not Configured] $\Pi \sigma$.

Setting	Description
0...100 %	Setting range Factory setting: –

[Mains Voltage] $\upsilon L \eta$

Mains voltage based on AC bus measurement, motor running or stopped.

Setting	Description
1.0...6,553.5 Vac	Setting range: [no meas.] $\upsilon L \eta \eta K$ is displayed if no value is measured. Factory setting: –

[Mains Voltage phase 1-2] $\upsilon L I$

Mains voltage phase 1-2 measurement.

This parameter cannot be accessed on ATV630C22N4...C31N4.

Setting	Description
-3,276.7...3,276.7 Vac	Setting range: [No meas.] $\mu L n u n K$ is displayed if no value is measured. Factory setting: –

[Mains Voltage phase 2-3] $\mu L 2$

Mains voltage phase 2-3 measurement.

This parameter cannot be accessed on ATV630C22N4...C31N4.

Setting	Description
-3,276.7...3,276.7 Vac	Setting range: [No meas.] $\mu L n u n K$ is displayed if no value is measured. Factory setting: –

[Mains Voltage phase 3-1] $\mu L 3$

Mains voltage phase 3-1 measurement

This parameter cannot be accessed on ATV630C22N4...C31N4.

Setting	Description
-3,276.7...3,276.7 Vac	Setting range: [No meas.] $\mu L n u n K$ is displayed if no value is measured. Factory setting: –

[Mains Current] $i L n$

Actual mains current (effective value of the fundamental mode).

Accuracy: 2% (related to drive nominal current).

This parameter can be accessed on ATV680 and ATV6B0.

Setting	Description
According to drive rating	Setting range Factory setting: –

[Mains Frequency] $F R C$

Actual mains frequency.

This parameter can be accessed on ATV680 and ATV6B0.

Setting	Description
0.0...999.9 Hz	Setting range Factory setting: –

[DC Bus Voltage] V_{bus}

DC bus voltage.

Setting	Description
0...6,553.5 Vdc	Setting range: [No meas.] $uLnunK$ is displayed if no value is measured. Factory setting: –

[Drive Therm State] t_{HD}

Drive thermal state.

The normal drive thermal state is 100%, the **[Drive Overheating] σ_{HF}** threshold is set to 118%

Setting	Description
0...200%	Setting range Factory setting: –

[Used Param. Set] $CFP5$ ★

Used parameter set.

Configuration parameter status (can be accessed if parameter switching function has been enabled).

Setting	Code / Value	Description
[None]	$n\sigma$	Not assigned
[Set N°1]	$CFP1$	Parameter set 1 active
[Set N°2]	$CFP2$	Parameter set 2 active
[Set N°3]	$CFP3$	Parameter set 3 active

[Config. active] $CnF5$

Active configuration.

Setting	Code / Value	Description
[In progress]	$n\sigma$	Transitory state
[Config. No.0]	$CnFD$	Configuration 0 active

[Thermal monitoring]

[Thermal Monitoring] Ε Ρ Π - Menu

Access

[Display] → [Thermal Monitoring]

About This Menu

The content of this menu can be accessed if [Thermal monitoring] Ε Ρ Ρ - function has been activated , page 165.

This menu shows the present thermal value measured via analog inputs used.

[AI1 Th Value] Ε Η 1 V, [AI2 Th Value] Ε Η 2 V, [AI3 Th Value] Ε Η 3 V, [AI4 Th Value] Ε Η 4 V, [AI5 Th Value] Ε Η 5 V ★

AI1 thermal value, AI2 thermal value, AI3 thermal value, AI4 thermal value and AI5 thermal value.

NOTE: AI4 and AI5 can only be accessed if the I/O extension option module (VW3A3203) has been inserted.

Setting	Description
-15.0...200.0 °C (step: 0.1 °C) 5.0...392.0 °F (step: 0.1 °F)	Setting range (the unit depends on the setting of [Temperature unit] Σ υ Ε Ρ). Factory setting: Read-only parameter.

[PID display]

[PID display] $P \ , \ C -$ Menu

Access

[Display] → [PID display]

About This Menu

[Internal PID ref] $r \ P \ , \ \star$

Internal PID reference.

Setting 	Description
0...32,767	Setting range Factory setting: 150

[PID Reference] $r \ P \ C \ \star$

PID setpoint value.

Setting	Description
0...65,535	Setting range Factory setting: 0

[PID feedback] $r \ P \ F \ \star$

PID feedback value.

Setting	Description
0...65,535	Setting range Factory setting: 0

[PID Error] $r \ P \ E \ \star$

PID error value.

Setting	Description
-32,767...32,767	Setting range Factory setting: –

[PID Output] $r \ P \ \square \ \star$

PID output value.

Setting	Description
[PID Min Output] P o L ... [PID Max Output] P o h	Setting range Factory setting: _

[Counter management]

[Counter Management] $E L E -$ Menu

Access

[Display] → [Counter Management]

About This Menu

This menu shows the drive and motor-related counters.

[Motor Run Time] $r E H H$

Motor run time.

Run elapsed time display (resettable) in 0.1 hours (length of time the motor has been switched on).

Setting	Description
0.0...119,304.5 h	Setting range Factory setting: _

[Power-on Time] $P E H H$

Power-on time (resettable) or counter can be set to 0 by using the [Time Counter Reset] $r P r$ parameter.

Setting	Description
0.0...119,304.5 h	Setting range Factory setting: _

[Fan Operation Time] $F P b E$

Fan operation time.

As soon as [Fan Operation Time] $F P b E$ reach the predefined value of 45,000 hours, a warning [Fan Counter Warning] $F C E R$ is triggered.

[Fan Operation Time] $F P b E$ counter can be set to 0 by using the [Time Counter Reset] $r P r$ parameter.

Setting	Description
0...500,000 h	Setting range Factory setting: Read Only

[Nb Of Start] $n S \Pi$

Number of motor starts (resettable) or counter can be set to 0 by using the [Time Counter Reset] $r P r$ parameter.

Setting	Description
0...4,294,967,295	Setting range Factory setting: _

[Cabinet Fan Opt Time] F C E

Cabinet Fan operation time

If **[Cabinet Fan Oper Time] F C E** has reached the predefined value of 30,000 hours, a warning **[Cabinet Fan Counter Warn] F C C R** is triggered.

This parameter can be accessed on ATV●30●●●F, ATV●50●●●F, ATV●60, ATV●80, and ATV●L0.

Setting	Description
0...500,000 h	Setting range Factory setting: Read Only

[AFE Run Time] b r H H

AFE Run Time

This parameter can be accessed on ATV680 and ATV6B0.

Setting	Description
0.0...429,496,729.5 h	Setting range Factory setting: _

[AFE Power-On Time] b P H H

AFE brick power on elapsed time

This parameter can be accessed on ATV680 and ATV6B0.

Setting	Description
0.0...429,496,729.5 h	Setting range Factory setting: _

[AFE Fan Operation Time] F b R E

AFE Fan Operation Time

If **[AFE Fan Operation Time] F b R E** has reached the predefined value of 45,000 hours, a warning **[AFE Fan Counter Warn] F C b R** is triggered.

This parameter can be accessed on ATV680 and ATV6B0.

Setting	Description
0...50,000 h	Setting range Factory setting: _

[AFE Nb of starts] *b n S A*

AFE number of starts

This parameter can be accessed on ATV680 and ATV6B0.

Setting	Description
0...4,294,967,295	Setting range Factory setting: _

[Time Counter Reset] *r P r*

Time counter reset.

Setting ()	Code / Value	Description
[No]	<i>n o</i>	No Factory setting
[Run Time Reset]	<i>r t H</i>	Run time reset
[Power ON Time Reset]	<i>P t H</i>	Power ON time reset
[Reset Fan Counter]	<i>F t H</i>	Reset fan counter
[Clear NSM]	<i>n S Π</i>	Clear number of motor starts
[Efficiency MAX]	<i>E F Y K</i>	Efficiency max
[Efficiency MIN]	<i>E F Y J</i>	Efficiency min
[Flow Rate MAX]	<i>F S I K</i>	Flow rate max
[Flow Rate MIN]	<i>F S I J</i>	Flow rate min
[Reset Total Quantity]	<i>F S I C</i>	Reset total quantity
[Clear AFE Fan]	<i>F b R t</i>	Clear AFE Fan operation time ⁽¹⁾
[Clear Cabinet Fan]	<i>F C t</i>	Clear cabinet fan operation time NOTE: This selection can be accessed on ATV●30●●●F, ATV●50●●●F, ATV●60, ATV●80, and ATV●L0.
[Clear AFE Power ON Time]	<i>b P t h</i>	Clear AFE power ON time ⁽¹⁾
[Clear BRTH]	<i>b r t h</i>	Clear AFE run time ⁽¹⁾
[Clear AFE Nb. start]	<i>b n S A</i>	Clear AFE brick number of start ⁽¹⁾
1 This selection can be accessed on ATV680 and ATV6B0.		

[Other state]

[Other state] $55E$ - Menu

Access

[Display] \rightarrow [Other state]

About This Menu

List of secondary states.

List

[Anti-Jam pending] JRP

[Anti-Jam In Progress] JRP_r

[Internal Error 22] IFP

[PipeFill In Progress] FLL

[InPres Comp Active] PPC

[Sleep Active] SLP

[Priming pump running] $PPON$

[Jockey pump running] $JPON$

[Modbus Com Inter.] $SLFI$

[Sleep Boost active] $SLPB$

[Sleep Check Active] $RSLC$

[Set 1 active] $CFP1$

[Set 2 active] $CFP2$

[Set 3 active] $CFP3$

[Set 4 active] $CFP4$

[Automatic restart] $RUto$

[DC Bus Charged] dbL

[Fast stop Active] FSE

[Fallback Frequency] Frf

[Speed Maintained] rLS

[Type of stop] SEt

[DC Bus Ripple Warn] $dCrW$

[Ref Freq Warning] SrR

[Forward] $\Pi F r d$

[Reverse] $\Pi r r S$

[Autotuning] $Eu n$

[VxCtrl Running] VCL

[VxCtrl Learning] VCL

[I/O map]

[I/O map] IOM- Menu

Access

[Display] → [I/O map]

About this Menu

This menu shows information about the inputs and the outputs of the drive such as: the function assigned, the configuration and the present value or state.

The information is separated in different categories/menus:

- **[Digital Input Map]** $L \ , \ R -$: The mapping of the digital inputs,
- **[Analog inputs image]** $R \ , \ R -$: The image of the analog inputs,
- **[Digital Output Map]** $L \ \square \ R -$: The mapping of the digital outputs and relays,
- **[Analog Outputs image]** $R \ \square \ R -$: The image of the analog outputs ,
- **[Freq. signal image]** $F \ 5 \ , \ -$: The image of the pulse inputs,
- **[Cabinet Digital Input Map]** $L \ , \ \mathcal{L} \ R -$: The mapping of the cabinet digital inputs,
- **[Cabinet Digital Output Map]** $L \ \square \ \mathcal{L} \ R -$: The mapping of the cabinet digital outputs.

The parameters available in this menu are in read-only mode, they cannot be configured.

For more information on the inputs/outputs configuration, refer to the submenus in **[Complete settings] → [Input/Output]**.

[Digital Input Map] $L \ , \ R -$

This menu is used to display the state of digital inputs. Use the touch wheel to scroll through the digital inputs:

- STO_A and STO_B: inputs of the safety STO function. For more information, refer to the embedded safety function manual of the drive.
- Digital inputs DI1 to DI6 of the drive,
- Optional digital inputs DI11 to DI16 if VW3A3203 Extended I/O module has been inserted.

On the Graphic Display Terminal , click the digital input to see all the functions that are assigned to the digital input in order to verify the compatibility with the multiple assignments (low level assignment and high level assignment). If no functions have been assigned, **[Not assigned]** $\Pi \square$ is displayed.

For more information on the digital inputs refer to **[Complete settings] → [Input/Output] → [DI/DQ]**.

[Analog inputs image] $R \ , \ R -$

This menu is used to display the value of analog inputs. Use the touch wheel to scroll through the analog inputs:

- **[AI1]** $R \ , \ \mathcal{L} -$ to **[AI3]** $R \ , \ \exists \mathcal{L} -$: Analog inputs AI1 to AI3 of the drive.
- **[AI4]** $R \ , \ 4 \mathcal{L} -$ and **[AI5]** $R \ , \ 5 \mathcal{L} -$: Optional analog inputs AI4 and AI5 if VW3A3203 Extended I/O module has been inserted,

The physical value of the analog input Aix shown in this menu corresponds to the parameter **[Aix]** $\Pi \square X \mathcal{L}$. The range and the unit depend on the customer configuration.

On the Graphic Display Terminal, click the analog input Aix (with 'x' from 1 to 5) to display:

- **[Aix Assignment]** $\Pi \square X \mathcal{R}$: all the functions associated with the analog input in order to verify, for example, compatibility problems with the multiple assignments,
- The minimum and maximum values according to the configured type **[Aix Type]** $\Pi \square X \mathcal{E}$:
 - **[Aix min value]** $\mu \square L X$ and **[Aix max value]** $\mu \square H X$ with **[Voltage]** $I \square \mu$ type,
 - **[Aix min. value]** $\mathcal{C} \square L X$ and **[Aix max. value]** $\mathcal{C} \square H X$ with **[Current]** $\square \mathcal{R}$ type.
- The configured value of the interference filtering: **[Aix filter]** $\Pi \square X \mathcal{F}$.

For more information on the analog inputs refer to **[Complete settings]** \rightarrow **[Input/Output]** \rightarrow **[Analog I/O]**.

[Digital Output Map] $L \square \mathcal{R} -$

This menu is used to display the state of relays and digital outputs. Use the touch wheel to scroll through them:

- R1 to R3: the relays of the drive.
- R4 to R6: the optional relays if VW3A3204 Extended relay module has been inserted.
- DQ11 and DQ12: the optional digital output if VW3A3203 Extended I/O module has been inserted.

On the Graphic Display Terminal, click the relay or the digital output to display:

- The function assigned to the digital output or the relay. If no functions have been assigned, **[Not assigned]** $\Pi \square$ is displayed,
- The delay time,
- The active level (high or low),
- The holding time.

For more information on the configuration of the digital outputs and the relays refer to **[Complete settings]** \rightarrow **[Input/Output]**.

[Analog Outputs image] $\mathcal{R} \square \mathcal{R} -$

This menu is used to visualize the value of analog outputs. Use the touch wheel to scroll through the outputs **[AQ1]** $\mathcal{R} \square I \mathcal{L} -$, **[AQ2]** $\mathcal{R} \square \mathcal{Z} \mathcal{L} -$ and .

The physical value of the analog output AQx displayed in this menu corresponds to the parameter **[AQx]** $\mathcal{R} \square X \mathcal{L}$. The range and the unit depend on the customer configuration.

On the Graphic Display Terminal, click the analog outputs to display:

- **[AQx Assignment]** $\mathcal{R} \square X$: the function associated with the analog output in order to verify, for example, compatibility problems with the multiple assignments,
- The minimum and maximum values according to the configured type **[AQx Type]** $\mathcal{R} \square X \mathcal{E}$:
 - **[AQx min value]** $\mu \square L X$ and **[AQx max value]** $\mu \square H X$ with **[Voltage]** $I \square \mu$ type,
 - **[AQx min value]** $\mathcal{R} \square L X$ and **[AQx max value]** $\mathcal{R} \square H X$ with **[Current]** $\square \mathcal{R}$ type.

- **[Scaling AQx min] $P 5 L X$** (respectively **[Scaling AQx max] $P 5 H X$**): The scaling of the lower limit (respectively upper limit) of the assigned parameter, as a percentage of the minimum (respectively maximum) possible variation.
- The configured value of the interference filtering: **[AQx filter] $P 9 X F$** .

For more information (such as the configuration), refer to **[Complete settings] → [Input/Output] → [Analog I/O]**.

[Freq. signal image] $F 5 \text{ , } -$

This menu is used to visualize the frequency of configured pulse inputs. Use the touch wheel to scroll through the pulse inputs: **[DI5 frequency measured] $P F C 5 -$** and **[DI6 frequency measured] $P F C 6 -$** . The displayed value corresponds to the parameter **[DIx Frequency Measured] $P F C X$** . The unit is in 0.01 Hz and the range is 0...42,949,672.95 Hz.

On the Graphic Display Terminal, click a pulse input to display information such as the function assigned to the pulse input, the low and high configured frequency and the interference filtering pulse input cut-off time of the low-filter.

For more information (such as the configuration), refer to **[Complete settings] → [Input/Output]**.

[Cabinet Digital Input Map] $L \text{ , } C R -$

It can be accessed on ATV●60, ATV●80 and ATV●L, equipped with cabinet IO, and if **[Access Level] $L R C$** is set to **[Expert] $E P r$** .

This menu is used to visualize the state of cabinet digital inputs. Use the touch wheel to scroll through the cabinet digital inputs D50 to D59.

On the Graphic Display Terminal, click the digital input to see all the functions that are assigned to the digital input in order to verify the compatibility with the multiple assignments (low level assignment and high level assignment). If no functions have been assigned, **[Not assigned] $\sigma \eta$** is displayed.

[Cabinet Digital Output Map] $L \sigma C R -$

It can be accessed on ATV●60, ATV●80 and ATV●L, equipped with cabinet IO, and if **[Access Level] $L R C$** is set to **[Expert] $E P r$** .

This menu is used to visualize the state of cabinet digital outputs. Use the touch wheel to scroll through the cabinet digital outputs.

On the Graphic Display Terminal, click the relay or the digital output to display:

- The function assigned to the digital output or the relay. If no functions have been assigned, **[Not assigned] $\sigma \eta$** is displayed,
- The delay time,
- The active level (high or low),
- The holding time.

[Communication map]

[Communication map] $\mathcal{L} \Pi \Pi -$ Menu

Access

[Display] → [Communication map]

About This Menu

This menu gives access to monitoring parameters linked to:

- The sources of command and references,
- The command and state registers,
- Fieldbus communication.

For more information about the command and reference refer to **[Command and Reference]** $\mathcal{L} r P -$ Menu , page 228 .

Topic	Description	Related manual
[Command Channel] $\mathcal{L} \Pi d \mathcal{L}$ parameter	This monitoring parameter shows the current active command channel. For more information , page 125.	-
[Cmd Register] $\mathcal{L} \Pi d$ parameter	This parameter shows the current value of the command register in hexadecimal. For more information see below , page 126.	-
[Ref Freq Channel] $r F \mathcal{L} \mathcal{L}$ parameter	This monitoring parameter shows the current active reference channel. For more information see below , page 126.	-
[Pre-Ramp Ref Freq] $F r H$ parameter	This monitoring parameter shows the current value of the Frequency reference before ramp. For more information see below , page 127.	-
[CIA402 State Reg] $E \mathcal{L} R$ parameter	This monitoring parameter shows the current value of the CIA402 state register in hexadecimal. For more information , page 127.	-
[Modbus network diag] $\Pi \eta d -$ Menu	This menu is related to the Modbus serial communication port on the bottom of the control block.	EAV64325
[Modbus HMI Diag] $\Pi d H -$ Menu	This menu is related to the Modbus serial communication port on the front of the control block. It is used by default for the Graphic Display Terminal .	-
[Ethernet Emb Diag] $\Pi P E -$ Menu	This menu is related to the Ethernet Embedded communication.	EAV64327
[Ethernet Module Diag] $\Pi \mathcal{L} E -$ Menu	This menu is related to the Ethernet-IP Modbus TCP fieldbus module (VW3A3720, 721).	EAV64328
[DeviceNet Diag] $d V \eta -$ Menu	This menu is related to the DeviceNet fieldbus module (VW3A3609).	EAV64330
[Profibus Diag] $P r b -$ Menu	This menu is related to the Profibus DP fieldbus module (VW3A3607)	EAV64329
[PROFINET Diag] $P r \eta -$ Menu	This menu is related to the Profinet fieldbus module (VW3A3627).	EAV64331

Topic	Description	Related manual
[Powerlink Diag] P W L - Menu	This menu is related to the POWERLINK fieldbus module (VW3A3619).	PHA99690
[Command word image] C W , - Menu	This menu contains command word images according to the communication sources. The description is similar to [CMD Register] C Π d . <ul style="list-style-type: none"> • [Modbus Cmd] C Π d 1 • [CANopen Cmd] C Π d 2 • [COM. Module Cmd.] C Π d 3 (for other fieldbus such as Profibus, ethernet option, etc.) • [Ethernet Emdb cmd.] C Π d 5 	-
[Freq. ref. word map] r W , - Menu	This menu contains frequency reference images according to the communication sources. The description is similar to [Ref Frequency] LFR. <ul style="list-style-type: none"> • [Modbus Ref Freq] L F r 1 • [CAN Ref Freq] L F r 2 • [Com Module Ref Freq] L F r 3 (for other fieldbus such as Profibus, ethernet option, etc.) • [Ethernet Emdb Ref Freq] L F r 5 <p>NOTE: the unit depends on the bit 9 of CMI: the internal command register. Refer to the communication parameters for more information , page 15.</p>	-
[CANopen map] C n Π - Menu	This menu is related to the CANopen module (VW3A3608, VW3A3618, VW3A3628).	EAV64333

[Command Channel] C Π d C

Command channel.

Read only parameter. This monitoring parameter shows the current active command channel.

Setting	Code / Value	Description
[Terminals]	t E r	Command via terminal block Factory Setting
[Ref.Freq-Rmt. Term]	L C C	Command via Graphic Display Terminal
[Ref. Freq-Modbus]	Π d b	Command via Modbus
[Ref. Freq-CANopen]	C R n	Command via CANopen if a CANopen module has been inserted
[Ref. Freq-Com. Module]	n E t	Command via fieldbus module if a fieldbus module has been inserted
[Embedded Ethernet]	E t H	Command via Embedded Ethernet
[PC tool]	P W 5	Command via commissioning software.

[Cmd Register] $\mathcal{L} \Pi \mathcal{L}$

Command register (depending on the selected profile using **[Control Mode] $\mathcal{L} H \mathcal{L} F$** and depending on the type of wire control using **[2/3-wire control] $\mathcal{L} \mathcal{L} \mathcal{L}$**).

This parameter shows the current value of the command register in hexadecimal.

Bit	Description, Value		
	CiA402 profile (CHCF = SIM or SEP)	2-wire I/O profile (CHCF = IO and TCC=2C)	3-wire transition I/O profile (CHCF=IO, TCC=3C)
0	Set to 1: "Switch on" /Contactor command	Forward (on state) command: 0: No forward command 1: Forward command NOTE: The assignment of bit 0 cannot be modified. It corresponds to the assignment of the terminals. It can be switched. Bit 0 Cd00 is only active if the channel of this control word is active.	Stop (run authorization): 0: Stop 1: Run is authorized on a forward or reverse command NOTE: The assignment of bits 0 and 1 cannot be modified. It corresponds to the assignment of the terminals. It can be switched. Bits 0 Cd00 and 1 Cd01 are only active if the channel of this control word is active.
1	Set to 0: "Disable voltage" /Authorization to supply AC power	Can be assigned to commands	Forward (on 0 to 1 rising edge) command
2	Set to 0: "Quick stop"		Can be assigned to commands
3	Set to 1: "Enable operation" /Run command		
4 to 6	Reserved (=0)		
7	"Fault reset" acknowledgment active on 0 to 1 rising edge		
8	Set to 1: Halt stop according to the [Type Of Stop] $\mathcal{L} \mathcal{L} \mathcal{L}$ parameter without leaving the operation enabled state		
9 and 10	Reserved (=0)		
11 to 15	Can be assigned to commands		

[Ref Freq Channel] $r F \mathcal{L} \mathcal{L}$

Active channel of reference frequency. Read-only parameter.

This monitoring parameter shows the current active reference channel.

Setting	Code / Value	Description
[Terminals]	$\mathcal{L} E r$	Reference via terminal block Factory Setting
[Ref.Freq-Rmt. Term]	$\mathcal{L} \mathcal{L} \mathcal{L}$	Reference via Graphic Display Terminal
[Ref. Freq-Modbus]	$\Pi d b$	Reference via Modbus
[Ref. Freq-CANopen]	$\mathcal{L} A \eta$	Reference via CANopen if a CANopen module has been inserted

Setting	Code / Value	Description
[Ref. Freq-Com. Module]	$n E L$	Reference via fieldbus module if a fieldbus module has been inserted
[Embedded Ethernet]	$E L H$	Reference via Embedded Ethernet
[PC tool]	$P W S$	Reference via commissioning software.

[Pre-Ramp Ref Freq] $F r H$

Frequency reference before ramp (signed value). Read-only parameter.

It enables to display the reference frequency (before ramp) applied to the motor, regardless of which channel for reference value has been selected (see , page 228)

Setting	Description
-500.0...500.0 Hz	Range value: The value cannot go higher than [High Speed] $H S P$ and lower than $-1 * [High Speed] H S P$.

[CIA402 State Reg] $E L R$

CIA402 State Register.

With CIA402 profile, the combination of bits 0, 1, 2, 4, 5 and 6 defines the state in the DSP 402 state chart (see the annex).

The value is identical in the CiA402 profile and the I/O profile. In the I/O profile, the description of the values is simplified and does not refer to the CiA402 (Drivecom) state chart.

Bit	Description	
	CiA402 profile (CHCF = SIM or SEP)	I/O profile (CHCF = IO)
0	"Ready to switch on", 1 = awaiting power section line supply	Reserved (= 0 or 1)
1	"Switched on", ready	0: Not ready / 1: Ready
2	"Operation enabled", running	Running: 0: The drive does not start if a reference other than zero is applied 1: Running, if a reference other than zero is applied, the drive can start
3	Operating detected error state: 0: Inactive / 1: Active	Operating detected error state: 0: Inactive / 1: Active
4	"Voltage enabled", 1=power stage supply present NOTE: When the drive is powered by the power stage only, this bit is always at 1.	Power stage supply (1=present / 0=unavailable) NOTE: When the drive is powered by the power stage only, this bit is always at 1.
5	Quick stop (0 = active)	Reserved (= 1)
6	"Switched on disabled", power stage supply locked	Reserved (= 0 or 1)
7	1: Warning	1: Warning
8	Reserved (= 0)	Reserved (= 0)
9	Remote: 0: Command or reference via the Graphic Display Terminal	

Bit	Description	
	CiA402 profile (CHCF = SIM or SEP)	I/O profile (CHCF = IO)
	1: Command or reference via the network	
10	1: The targeted reference has been reached NOTE: When the drive is in speed mode, this is the speed reference.	1: The reference has been reached
11	"Internal limit active": 0: The reference is within the limits 1: The reference is not within the limits NOTE: When the drive is in speed mode, the limits are defined by LSP and HSP parameters.	Reference outside limits: 0: The reference is within the limits 1: The reference is not within the limits NOTE: When the drive is in speed mode, the limits are defined by LSP and HSP parameters.
12	Reserved (=0)	Reserved (= 0)
13	Reserved (=0)	Reserved (= 0)
14	"Stop key", STOP via stop key: 0: STOP key not pressed 1: Stop triggered by the STOP key	
15	"Direction", direction of rotation: 0: Forward rotation at output 1: Reverse rotation at output	

[Data logging]

[Distributed logging] $d L \sigma -$ Menu

Access

[Display] → [Data logging] → [Distributed logging]

About This Menu

This menu is used to store data following specific parameters.

The distributed logging function allows to log up to four parameter distributions at the same time. Each parameter storage is synchronized with the same sample time.

The result of this function gives the possibility to extract a bar graph with 10 bars (every 10% of the defined maximum value) to visualize the distribution for each of the four selected parameters.

NOTE: Any modification of the data logging function configuration will clear the data previously stored.

This function aims at extracting samples of data to store them. When available, these samples can be uploaded by other tools (SoMove and/or Webserver). Data logging meets the need to record and store data over time.

The drive can store the following data:

Type of [Data logging]	Description	[Data logging] storage: Automatic/ Manual	Access
Drive identification	Drive identification data	Automatic, in [Dashboard] $d S H -$ menu	SoMove Webserver
Even warning logging	Warning logging	Automatic, in [Dashboard] $d S H -$ menu	SoMove Webserver
Even error logging	Error logging	Automatic, in [Dashboard] $d S H -$ menu	SoMove Webserver
Distribution logging	4 Distribution data	Manual	Webserver
Energy logging	1 Energy logging data	Automatic, in [Dashboard] $d S H -$ menu	SoMove Webserver

Activation

To activate [Distributed logging] $d L \sigma -$:

- Select 1 to 4 data to store with [Log dstrb prm select] $L d P -$
- Set [Log Distrib State] $L d E \eta$ to [Start] $S t A r t$

The logging starts as soon as the motor is running.

To stop logging, set [Log Distrib State] $L d E \eta$ to [Stop] $S t o p$.

[Log Distrib State] $L d E \eta$

Logging distribution state.

Setting ()	Code / Value	Description
[Stop]	<i>S t o P</i>	Distribution logging disabled Factory setting
[Start]	<i>S t A r t</i>	Distribution logs only when the motor is started
[Always]	<i>A L W A Y S</i>	Distribution logs all the time
[Reset]	<i>r E S E T</i>	Distribution logging reset (configuration, data)
[Clear]	<i>C L E A r</i>	Clear distribution data
[Error]	<i>E r r o r</i>	An error has been detected during distribution logging

[Log dstrb prm select] *L d P - Menu*

Access

[Display] → [Data logging] → [Distributed logging] → [Log dstrb prm selectg]

About This Menu

This menu allows you to select up to 4 parameters for data logging. The peak value for each parameter is also stored.

[Log Distrib. Data 1] *L d d 1* to [Log Distrib. Data 4] *L d d 4*

Logging distribution data 1 to 4.

Setting ()	Code / Value	Description
[Distrib. Log. Disable]	<i>n o</i>	Distribution logging disable Factory setting
[Motor Frequency]	<i>r F r</i>	Motor frequency
[Motor Current]	<i>L C r</i>	Motor current
[Motor Speed]	<i>S P d</i>	Motor speed
[Motor Voltage]	<i>u o P</i>	Motor voltage
[Motor Mech. Power]	<i>o P r W</i>	Motor mechanical power
[Input Elec. Power]	<i>i P r W</i>	Input electrical power
[Output Elec. Power]	<i>E P r W</i>	Output electrical power
[Motor Torque]	<i>o T r</i>	Motor torque
[Mains Voltage]	<i>u L n</i>	Mains voltage
[DC BUS Voltage]	<i>V b u S</i>	DC BUS voltage
[PID Feedback]	<i>r P F</i>	PID feedback
[AI2 Th Value]	<i>t H 2 V</i>	Thermal sensor AI2

Setting ()	Code / Value	Description
[AI3 Th Value]	$E H 3 V$	Thermal sensor AI3
[AI4 Th Value]	$E H 4 V$	Thermal sensor AI4
[AI5 Th Value]	$E H 5 V$	Thermal sensor AI5
[Drive Thermal State]	$E H d$	Drive thermal state
[Motor Therm State]	$E H r$	Motor thermal state
[Installation Flow]	$F S 1 u$	Installation flow
[Pump Flow]	$F S 2 u$	Pump flow
[Inlet Pressure Value]	$P S 1 u$	Inlet pressure sensor
[Outlet Pressure Value]	$P S 2 u$	Outlet pressure sensor
[Energy Consum. Ind.]	$E C i$	Energy consumption indicator
[Pump Efficiency]	$E F y$	Pump efficiency
[Energy Perf. Ind.]	$E P i$	Energy performance indicator
[Mains Current]	$i L n$	Main estimated current
[Input Reactive Power]	$i q r w$	Re-active Electrical input power estimation
[Input Power factor]	$P w F$	Main power factor

[Distributed logging] $d L \square -$ Menu

Access

[Display] → [Data logging] → [Distributed logging]

About This Menu

NOTE: If a log data exceeds the user defined maximum values for log distribution data, this value will not be stored in the log distribution.

[Log Distrib Slp Time] $L d S t$

Logging distribution sample time.

Setting ()	Code / Value	Description
[200 ms]	$2 0 0 0 5$	200 ms
[1 second]	$1 5$	1 s Factory setting

Setting $\left(\right)$	Code / Value	Description
[2 second]	2 5	2 s
[5 second]	5 5	5 s

[Dist Max Val 1] $L d \Pi 1$ to [Dist Max Val 4] $L d \Pi 4$

Maximum value of the log distribution data 1 to maximum value of the log distribution data 4.

The defined maximum value corresponds to 100 % of the stored data. Adjust the maximum value to adapt the full range of the logging distribution data.

Setting $\left(\right)$	Description
10...65,535	Setting range Factory setting: 65,535 (the setting can be adapted when modifying [Log Distrib. Data 1] $L d \Pi 1$...[Log Distrib. Data 4] $L d \Pi 4$).

[Complete settings] C 5 E -

What's in This Chapter

Overview	135
[Macro configuration]	138
[Motor parameters] P P A - Menu	140
[Define system units]	195
[Sensors assignment]	200
[Command and Reference] C r P - Menu	228
[Pump functions] - [Booster control]	244
[Pump functions] - [Level control]	281
[Pump functions] - [PID controller]	306
[Pump functions] - [Sleep/wakeup]	327
[Pump functions] - [Feedback monitoring]	343
[Pump functions] - [Pump characteristics]	345
[Pump functions] - [Sensorless flow estimation]	353
[Pump functions] - [dP/Head Correction]	356
[Pump functions] - [Pump start stop]	358
[Pump functions] - [Pipe fill]	363
[Pump functions] - [Friction loss compensation]	368
[Pump functions] - [Jockey pump]	372
[Pump functions] - [Priming pump ctrl]	375
[Pump functions] - [Flow limitation]	379
[Pump functions] - [Vortex Control]	382
[Pump monitoring] - [Pumpcycle monitoring]	389
[Pump monitoring] - [Anti jam]	392
[Pump monitoring] - [Dry run Monit]	399
[Pump monitoring] - [Pump low flow Monit]	403
[Pump monitoring] - [Thermal monitoring]	409
[Pump monitoring] - [Inlet pressure monitoring]	410
[Pump monitoring] - [Outlet pressure monitoring]	415
[Pump monitoring] - [High flow monitoring]	420
[Fan] - [PID controller]	423
[Fan] - [Feedback monitoring]	423
[Fan] - [Jump frequency]	424
[Fan]	426
[Generic functions] - [Speed limits]	429
[Generic functions] - [Ramp]	433
[Generic functions] - [Ramp switching]	437
[Generic functions] - [Stop configuration]	439
[Generic functions] - [Auto DC injection]	445
[Generic functions] - [Ref. operations]	448
[Generic functions] - [Preset speeds]	450
[Generic functions] - [+/- speed]	453
[Generic functions] - [Jump frequency]	456
[Generic functions] - [PID controller]	456
[Generic functions] - [Feedback mon.]	456
[Generic functions] - [Threshold reached]	457
[Generic functions] - [Mains contactor command]	459
[Generic functions] - [Output contactor cmd]	462
[Generic functions] - [Reverse disable]	466
[Generic functions] - [Torque limitation]	467
[Generic functions] - [Parameters switching]	469
[Generic functions] - [Stop after speed timeout]	476
[Generic functions] - [Active Front End]	478
[Generic monitoring]	479
[Input/Output] - [I/O assignment]	487
[Input/Output] - [DI/DQ]	492
[Input/Output] - [Analog I/O]	501
[Input/Output] - [Relay]	520
[Error/Warning handling]	529
[Maintenance]	569
[Cabinet I/O Function] C A b F -	576

Introduction



[Complete settings] \llcorner \llcorner \llcorner - menu presents all the settings related to drive functions for:

- Motor and drive configuration
- Application functions
- Monitoring functions

Overview

Application Control Mode

Introduction

There are five application control modes for the pump controller.

The application control mode is determined according to the selected channel and **[PID regul.] P , d** mode.

This table presents the priority order of the control modes:

Priority	Channel	Function	Control mode
1	Local	<i>F L o</i> or <i>E K</i>	Local
2	Channel 2	<i>F r 2</i>	Override
3	Channel 1	<i>P , n</i>	PID manu
4	Channel 1	<i>P , s P</i>	PID auto
5	Channel 1	<i>F r 1</i> or <i>F r 1 b</i>	Speed control

Application Control Functions

Application control functions are not all available in all modes. This table presents the availability of each function according to the selected mode:

Function	Channel 1			Channel 2	Local	Applica- tion status
	<i>P , d</i> Manu	<i>P , d</i> Auto	No <i>P , d</i>			
Reference Frequency Source	<i>P , n</i>	<i>P , s P</i>	<i>F r 1</i> or <i>F r 1 b</i>	<i>F r 2</i>	<i>b n P</i> or <i>F L o C</i>	–
Centrifugal Pump Start & Stop	Yes	Yes	Yes	Yes	Yes	–
Thermal Pump Monitoring	Yes	Yes	Yes	Yes	Yes	–
Anti-Jam	Yes	Yes	Yes	No	No	<i>A J A n</i>
Priming Pump Control	Yes	Yes	Yes	No	No	<i>P r , n</i>
Pipe Fill	Yes	Yes	Yes	No	No	<i>F , L L</i>
Dry Run Pump Monitoring	Yes	Yes	Yes	No	No	–
Pump Low Flow Monitoring	Yes	Yes	Yes	No	No	–
Pumpcycle Monitoring	Yes	Yes	Yes	No	No	–
High Flow Monitoring	Yes	Yes	Yes	No	No	–
Flow Limitation	Yes	Yes	Yes	No	No	<i>F L , n</i>
Outlet Pressure Monitoring	Yes	Yes	Yes	No	No	–
Inlet Pressure Monitoring	Yes	Yes	Yes	No	No	<i>C o n P</i>
Process Control (PID)	Yes (Manu)	Yes (Auto)	Not configured	No	No	<i>A u t o</i> <i>n A n u</i>
PID Controller	Yes	Yes	No	No	No	<i>b o o - S t</i>

Function	Channel 1			Channel 2	Local	Applica- tion status
	<i>P, d</i> Manu	<i>P, d</i> Auto	No <i>P, d</i>			
						<i>SLE-EP</i>
Sleep Wake-Up (Pressure Control)	No	Yes	No	No	No	–
Advanced sleep Checking (Pressure Control)	No	Yes	No	No	No	–
Friction Loss Compensation	No	Yes	No	No	No	–
Jockey Pump Control	No	Yes	No	No	No	–
PID Feedback Monitoring	No	Yes	No	No	No	–
Stop After Speed Timeout	Yes	No	Yes	Yes	Yes	<i>SLE-EP</i>
Multi-pump Management	Yes (1)	Yes (1)	Yes (1)	–	–	–
Booster Control	Yes	Yes	Yes	No	No	–
Level Control	N/A	N/A	Yes	No	No	–

1 Multi-pump Management is active for Booster or Level Control. When Booster and Level Control are both inactive, all auxiliary pumps are stopped.

Reference Channel Overview with PID Configured

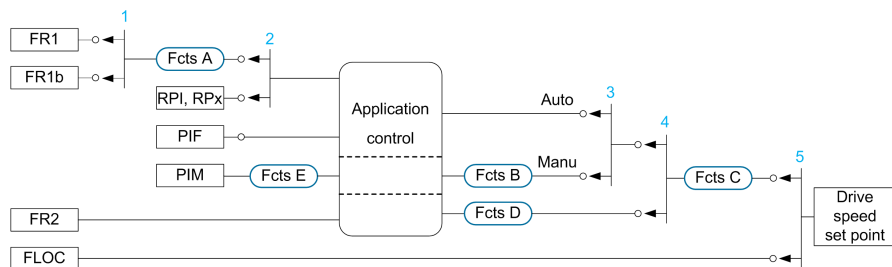

- 1 Commutation between channel 1 and channel 1b done with **[Acceleration 2]** *rCb* parameter
- 2 Choice of the process setpoint done with **[Intern PID Ref]** *P, d* parameter
- 3 Manual function of the **[PID regul.]** *P, d*, commutation done with **[Auto/Manual assign.]** *PMan* parameter
- 4 Choice between channel 1 and channel 2 done with **[Freq Switch Assign]** *rFL* parameter
- 5 Forced local mode activated by the function **[Forced Local Assign]** *FL0* or **[T/K]** *FonEK*

Reference Channel Overview with PID Not Configured

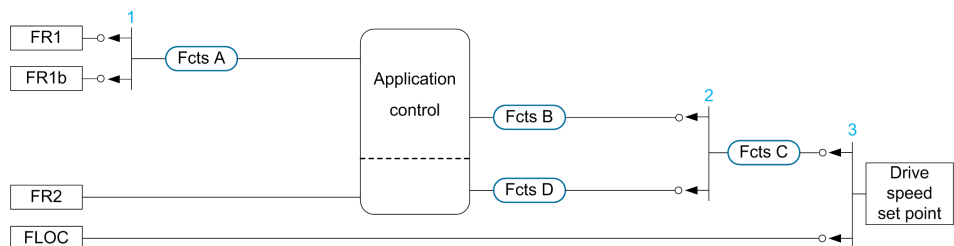

- 1 Commutation between channel 1 and channel 1b done with **[Acceleration 2]**
r C b parameter
- 2 Choice between channel 1 and channel 2 done with **[Freq Switch Assign]**
r F C parameter
- 3 Forced local mode activated by the function **[Forced Local Assign]** F L a or **[T/K]** F o t K

Monitoring Functions

This table presents the function availability depending on the application status:

Applica- tion status	System monitoring functions			Pump monitoring functions (pump running)			
	Outlet low pressure	Outlet high pressure	High flow	Inlet low pressure	Pump low flow	Dry run	Pumpcycle
A J A Π	No	No	No	No	No	No	Only 1 per cycle
P r i Π	No	Yes	Yes	N/A or no	N/A	N/A	N/A
F i L L	No	Yes	Yes	Yes	Yes	Yes	Each start
r u n, Π A n u, A u t o, F L i Π, C o Π P	Yes	Yes	Yes	Yes	Yes	Yes	Each start
b o o S t	Yes	Yes	Yes	Yes	Yes	Yes	N/A
S L E E P	Yes	Yes	Yes	N/A or no	N/A	N/A	N/A
J o C K - E Y	Yes	Yes	Yes	Yes (1)	Yes (1)	Yes (1)	Each start (1)

1 If the VSD pump is used as a jockey pump

[Macro configuration]

[Macro configuration] *Π ℓ r -* Menu

Access

[Complete settings] → [Macro configuration]

About This Menu

This menu allows to select an application type in order to display only the parameters and menus useful for the selected application.

The application type selection should be done prior to the application settings.

Application compatibility

The following table shows the functions that can be configured depending of [Application Selection] *APPℓ* value.

Function	[Application Selection] <i>APPℓ</i>		
	[Generic Pump Control] <i>ℓ P Π P</i>	[Pump Level Control] <i>ℓ E V E ℓ</i>	[Pump Booster Control] <i>b o o s t</i>
[Pump characteristics] <i>ℓ ℓ r -</i>	Yes	Yes	Yes
[Sensorless flow estimation] <i>5 F E -</i>	Yes	Only for Lead Pump in architectures with 1 variable speed pump. Available for all pumps in multiple variable speed pump architectures.	
[Pump start stop] <i>P S ℓ -</i>	Yes	Yes	Yes
[Thermal monitoring] <i>ℓ P P -</i>	Yes	Yes	Yes
[Anti-jam monit] <i>J R Π -</i>	Yes	Only for Lead Pump in architectures with 1 variable speed pump. Available for all pumps in multiple variable speed pump architectures.	
[Priming pump ctrl] <i>P P ℓ -</i>	Yes	Only for Lead Pump in architectures with 1 variable speed pump. Available for all pumps in multiple variable speed pump architectures.	
[Pipe fill] <i>P F , -</i>	Yes	Not available	Yes
[Dry run Monit] <i>d Y r -</i>	Yes	Only for Lead Pump in architectures with 1 variable speed pump. Available for all pumps in multiple variable speed pump architectures.	
[Pump low flow Monit] <i>P L F -</i>	Yes	Only for Lead Pump in architectures with 1 variable speed pump. Available for all pumps in multiple variable speed pump architectures.	
[Pumpcycle monitoring] <i>ℓ S P -</i>	Yes	Only for Lead Pump in architectures with 1 variable speed pump if no Lead Pump Alternation configured. Available for all pumps in multiple variable speed pump architectures.	

Function	[Application Selection] <i>A P P L</i>		
	[Generic Pump Control] <i>G P P P</i>	[Pump Level Control] <i>L E V E L</i>	[Pump Booster Control] <i>b o o S t</i>
[High flow monitoring] <i>H F P -</i>	Yes	Based on Installation Flow Sensor	
[Flow limitation] <i>F L P -</i>	Yes	Not available	Yes
[Outlet pressure monitoring] <i>o P P -</i>	Yes	Yes	Yes
[Inlet pressure monitoring] <i>i P P -</i>	Yes	Only Warning can be configured	Yes
[PID controller] <i>P i d -</i>	Yes	Not available	Required
[Sleep/Wakeup] <i>S P W -</i>	Yes	Not available	Yes
[Friction loss comp] <i>F L C -</i>	Yes	Not available	Yes
[Jockey pump] <i>J K P -</i>	Yes	Not available	Yes
[Feedback monitoring] <i>F K P -</i>	Yes	Not available	Yes
[Booster control] <i>b S t -</i>	Not available	Not available	Yes
[Level Control] <i>L V L -</i>	Not available	Yes	Not available

[Application Selection] *A P P L*

Application selection.

▲ WARNING
<p>UNANTICIPATED EQUIPMENT OPERATION</p> <p>If this parameter is changed, the functions of the current configuration are disabled. The assignments of the inputs and/or outputs of functions that are no longer used as a result of the modified setting of the parameter are reset to the factory settings.</p> <ul style="list-style-type: none"> • Verify that this change is compatible with the type of wiring used. <p>Failure to follow these instructions can result in death, serious injury, or equipment damage.</p>

Setting	Code / Value	Description
[Generic Pump Control]	<i>G P P P</i>	Generic pump control application Factory setting
[Pump Level Control]	<i>L E V E L</i>	Pump level control application
[Pump Booster Control]	<i>b o o S t</i>	Pump booster control application
[Generic Fan Control]	<i>F A n</i>	Generic fan control application

[Motor parameters] P P A - Menu

[Motor parameters] P P A - Menu

Access

[Complete settings] → [Motor parameters]

About This Menu

For an application where less than 110% of overload is required

- Power rating of the drive could be equal to power rating of the motor
- Normal rating should be used

For an application where more that 110% of overload is required (up to 150%)

- Power rating of the drive should be greater than power rating of the motor
- High rating could be used to pre-adjust motor nameplate parameter

High rating or Normal rating depend of the machine cycle.

If high rating is selected, drive current limitation is extended to 1.5 x I_n and maximum values of motor parameters linked to current and/or power are reduced. When switching from one to another selection, all the related parameters are set to their factory setting values.

In any case, the maximum current of the drive does not change. Setting the drive to high rating mode decreases the nominal values for the motor parameters. It means that for the same motor, an oversized drive is required in high rating mode.

ATV600 Motor Control Types

ATV600 drive embeds 6 motor control types which covers all the use cases depending of the application.

The following table shows the Motor Control types selection depending of the application needs:

Control	Motor Type	[Motor Control Type] 5 5 selection	Description
Open-Loop	Asynchronous motor	[U/F VC Standard] 5 5 d	U/F vector control law
		[U/F VC 5pts] u F 5	5 points U/F vector control law
		[U/F VC Quad.] u F 9	U/F vector control law for variable torque applications (pumps and fans).
		[U/F VC Energy Sav.] E L o	U/F vector control optimized for energy saving.
	Synchronous motor	[SYN_U VC] 5 9 u	Permanent magnet control law for variable torque applications
Reluctance motor	[Reluctance Motor] 5 r V L	Reluctance motor control law	

Parameters List for Asynchronous Motors

The following table shows the minimum parameters list that needs to be configured for asynchronous motors depending of **[Motor Control Type]** 5 5 5 selection:

NOTE: After setting these parameters, it is recommended to perform an **[Autotuning]** 5 5 5 to optimize the performances. If one of these parameters is modified, autotuning must be re-performed.

Parameters	[U/F VC Standard] 5 5 5	[U/F VC 5pts] 5 5 5	[U/F VC Quad.] 5 5 5	[U/F VC Energy Sav.] 5 5 5
[Motor Standard] 5 5 5	✓	✓	✓	✓
[Nominal Motor Power] 5 5 5 or [Motor 1 Cosinus Phi] 5 5 5 (1)	✓	✓	✓	✓
[Nom Motor Voltage] 5 5 5	✓	✓	✓	✓
[Nom Motor Current] 5 5 5	✓	✓	✓	✓
[Nominal Motor Freq] 5 5 5	✓	✓	✓	✓
[Nominal Motor Speed] 5 5 5	✓	✓	✓	✓
(1) Depending on [Motor Param Choice] 5 5 5				

Parameters List for Synchronous or Reluctance Motors

The following table shows the minimum parameters list that needs to be configured for synchronous or reluctance motors depending of **[Motor Control Type]** 5 5 5 selection:

NOTE: After setting these parameters, it is recommended to perform an **[Autotuning]** 5 5 5 to optimize the performances. If one of these parameters is modified, autotuning must be re-performed.

Parameters	[SYN_U VC] 5 5 5	[Reluctance Motor] 5 5 5
[Sync Nominal I] 5 5 5	✓	✓
[Nom SyncMotor Speed] 5 5 5	✓	✓
[Nom Motor torque] 5 5 5	✓	✓
[Pole pairs] 5 5 5	✓	✓
[Angle setting type] 5 5 5	✓	✓
[Autotuning Type] 5 5 5	✓	✓ (1)
(1) [Autotuning Type] 5 5 5 can be changed to optimize the performances with Reluctance motors.		

[Dual Rating] 5 5 5

Dual rating state.

Select the normal/heady duty depending on the overload required on the application.

NOTE: Modifying this parameter resets the motor tune parameters and, **[Tune Selection]** 5 5 5 is reset to **[Default]** 5 5 5. You will need to re-perform autotuning.

Setting	Code / Value	Description
[Normal Duty]	<i>n o r M L</i>	Normal rating, drive current limitation is 1.1 x In Factory setting
[Heavy Duty]	<i>H i G H</i>	High rating, drive current limitation is 1.5 x In

[Motor Control Type] 5 5 5

Motor control type.

Set this parameter according to the application and the type of motor. The selection must be done before entering motor parameter values.

NOTE: Modifying this parameter resets the motor tune parameters and, [Tune Selection] 5 5 5 is reset to [Default] 5 5 5. You will need to re-perform autotuning.

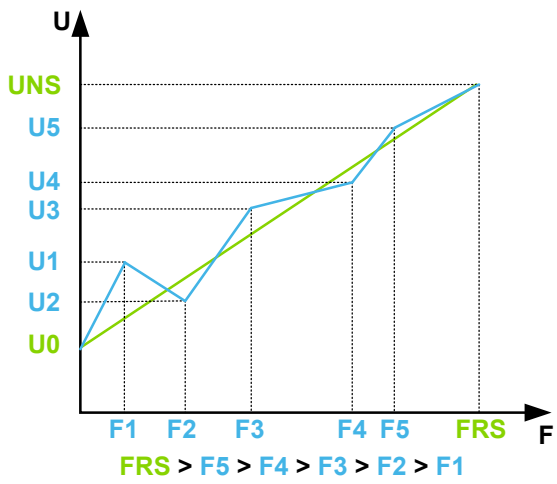
Setting	Code / Value	Description
[U/F VC Standard]	<i>5 5 d</i>	U/F VC Standard motor control type. For applications that require torque at low speed. This motor control type can be used for motors connected in parallel.
[U/F VC 5pts]	<i>u F 5</i>	U/F VC 5 point voltage/frequency: As [U/F VC Standard] 5 5 d profile but also supports the avoidance of resonance (saturation).  The profile is defined by the values of parameters <i>u n 5</i> , <i>F r 5</i> , <i>u 1</i> to <i>u 5</i> and <i>F 1</i> to <i>F 5</i> . The result is the blue curve. By default, if <i>u 1</i> to <i>u 5</i> and <i>F 1</i> to <i>F 5</i> are not modified (factory settings), the used profile is defined by 2 points (see the green curve). NOTE: U0 is the result of an internal calculation based on motor parameters and multiplied by <i>u F r</i> (%). U0 can be adjusted by modifying <i>u F r</i> value.
[U/F VC Quad.]	<i>u F 9</i>	U/F VC Quadratic: Motor control type dedicated to variable torque applications, typically used for pumps and fans. Factory setting
[SYN_U VC]	<i>5 5 n u</i>	Open-loop synchronous motor: Motor control type specific for permanent magnet synchronous motors. This motor control type is used for variable torque applications.

Setting	Code / Value	Description
[U/F VC Energy Sav.]	E L 0	Specific motor control type optimized for energy saving. This motor control type automatically reduces the drive output current according to the motor load. This automatic current level adaptation allows energy saving for periods when load is kept to a minimum and preserves the drive performance up to full load.
[Reluctance Motor]	S r V c	Synchronous reluctance Motor: Motor control type for reluctance motors. This motor control type is used for variable torque applications. If the maximum output current of the drive is not equal or greater than the motor current, this will lead to a lack of torque performances. [Stall Monitoring] S E P C function helps to prevent a motor overload by monitoring the motor current and the speed rise time.

[Data] n E d - Menu

Access

[Complete settings] → [Motor parameters] → [Motor data] → [Data]

About This Menu

⚠ WARNING

LOSS OF CONTROL

- Fully read and understand the manual of the connected motor.
- Verify that all motor parameters are correctly set by referring to the nameplate and the manual of the connected motor.
- If you modify the value of one or more motor parameters after having performed autotuning, the value of [Tune selection] STUN is reset to [Default] TAB and you must re-perform autotuning.

Failure to follow these instructions can result in death, serious injury, or equipment damage.

This menu contains motor-related data such as, but not limited to, motor nameplate parameters and parameters resulting from motor tuning. The parameters displayed in the menu mainly depend on [Motor control type] C E E selection:

- Asynchronous motor control types, i.e. if [Motor control type] C E E is set to:
 - [U/F VC Standard] S E d,
 - [U/F VC Quad.] u F q,
 - [U/F VC Energy Sav.] E C o,
 - [U/F VC 5pts] u F 5.

This table presents the steps to follow to set and optimize the motor data for asynchronous motor:

Step	Action
1	Enter the motor nameplate
2	Perform the [Autotuning] E u n operation
3	Adjust [Magnetizing current] i d R to optimize the behavior. This adjustment can be done if [Motor control type] C E E is set to V V C or [U/F VC Standard] S E d: <ul style="list-style-type: none"> • Start the motor at half nominal speed, at minimum load and without boost. • Check and note the [Ratio D-Axis error] r d R E value: <ul style="list-style-type: none"> ◦ If the [Ratio D-Axis error] r d R E value is lower than 0%, then [Magnetizing current] i d R may be reduced.. ◦ If the [Ratio D-Axis error] r d R E value is upper than 0%, then [Magnetizing current] i d R may be increased.. • Stop the motor for modify [Magnetizing current] i d R in accordance with the value of the [Ratio D-Axis error] r d R E (previously noted).

- Synchronous or reluctance motor control types, i.e. if [Motor control type] C E E is set to:
 - [Reluctance Motor] S r V c,
 - [SYN_U VC] S Y n u.

This table presents the steps to follow to set and optimize the motor data for synchronous or reluctance motor:

Step	Action
1	Enter the motor nameplate
2	Perform the [Autotuning] E U N operation
3	<p>Adjust [Syn. EMF constant] P H 5 to optimize the behavior. This adjustment can be done if [Motor control type] C E E is set to [SYN_U VC] S Y N U:</p> <ul style="list-style-type: none"> • Start the motor at minimal stable frequency available on the machine (at minimum load and without boost). • Check and note the [Ratio D-Axis error] r d R E value: <ul style="list-style-type: none"> ◦ If the [Ratio D-Axis error] r d R E value is lower than 0%, then [Syn. EMF constant] P H 5 may be increased. ◦ If the [Ratio D-Axis error] r d R E value is upper than 0%, then [Syn. EMF constant] P H 5 may be reduced. <p>[Ratio D-Axis error] r d R E value should be closed to 0%.</p> <ul style="list-style-type: none"> • Stop the motor for modify [Syn. EMF constant] P H 5 in accordance with the value of the [Ratio D-Axis error] r d R E (previously noted).

[Motor Standard] b F r ★

Motor standard.

This parameter is used to modify the presets and/or the units of several parameters, such as:

- [High Speed] H 5 P
- [Motor Freq Thd] F E d
- [Nom Motor Voltage] u n 5
- [Nominal Motor Freq] F r 5
- [Max Frequency] E F r

This parameter can only be accessed with asynchronous motor control types.

NOTE: Modifying this parameter resets the motor tune parameters and, [Tune Selection] S E U N is reset to [Default] E R B. Autotuning will need to be performed again.

Setting	Code / Value	Description
[50 Hz]	5 0	50Hz motor frequency — IEC Factory setting ⁽¹⁾
[60 Hz]	6 0	60Hz motor frequency — NEMA
⁽¹⁾ : The factory setting value is changed to [60 Hz] for ATV630...S6 catalog numbers.		

[Max Frequency] E F r

Maximum output frequency.

To help prevent [Motor Overspeed] S O F error, it is recommended to have [Max Frequency] E F r equal to or higher than 110% of [High Speed] H 5 P.

Setting	Description
10.0...500.0 Hz ⁽¹⁾ (step: 0.1 Hz)	Setting range Factory setting: 60 Hz, or preset to 72 Hz if [Motor Standard] b F r is set to [60 Hz] 6 0.
⁽¹⁾ The maximum of the range is 10 * [Nominal Motor Freq] F r 5 for an asynchronous law or 10 * [Sync Nominal Freq] F r 5 S for a synchronous law.	

[Nominal Motor Power] $n P r$ ★

Nominal motor power (given on the motor nameplate).

This parameter can only be accessed with asynchronous motor control types and if [Motor Param Choice] $n P C$ is set to [Mot Power] $n P r$.

NOTE: Modifying this parameter resets the motor tune parameters and, [Tune Selection] $5 E u n$ is reset to [Default] $E R b$. Autotuning will need to be performed again.

Setting	Description
According to drive rating ⁽¹⁾	Setting range in kW if [Motor Standard] $b F r$ is set to [50 Hz] $5 D$, in HP if [Motor Standard] $b F r$ is set to [60 Hz] $6 D$ Factory setting: according to the drive rating
^{(1):} If [Motor Standard] $b F r$ is set to [50 Hz] $5 D$, the step is 0.01 kW for drives with power range ≤ 15 kW. If the power range is between 18 and 160 kW (limits included), the step is 0.1 kW else it is 1 kW. If [Motor Standard] $b F r$ is set to [60 Hz] $6 D$, the step is 0.01 HP for drives with power range ≤ 20 HP. If the power range is between 25 and 250 HP (limits included), the step is 0.1 HP else it is 1 HP.	

[Nom Motor Voltage] $u n 5$ ★

Nominal motor voltage (given on the motor nameplate).

This parameter can only be accessed with asynchronous motor control types.

NOTE: Modifying this parameter resets the motor tune parameters and, [Tune Selection] $5 E u n$ is reset to [Default] $E R b$. Autotuning will need to be performed again.

Setting	Description
100...690 Vac (step: 1 Vac)	Setting range Factory setting: according to drive rating and [Motor Standard] $b F r$

[Nom Motor Current] $n I r$ ★

Nominal motor current (given on the motor nameplate).

This parameter can only be accessed with asynchronous motor control types.

NOTE: Modifying this parameter resets the motor tune parameters and, [Tune Selection] $5 E u n$ is reset to [Default] $E R b$. Autotuning will need to be performed again.

Setting	Description
0.15...1.5 I_n ⁽¹⁾ (step: 0.01 A ⁽²⁾)	Setting range Factory setting: according to drive rating and [Motor Standard] $b F r$
^{(1):} Corresponding to the rated drive current indicated in the installation manual and on the drive nameplate. ^{(2):} For drives with power range ≤ 15 kW. If the power range is between 18 and 160 kW (limits included), the step is 0.1 A else it is 1 A.	

[Nominal Motor Freq] $F r 5$ ★

Nominal motor frequency (given on the motor nameplate).

This parameter can only be accessed with asynchronous motor control types.

NOTE: Modifying this parameter resets the motor tune parameters and, **[Tune Selection] 5 $\epsilon \mu n$** is reset to **[Default] $\epsilon R b$** . Autotuning will need to be performed again.

Setting	Description
10.0...500.0 Hz (step: 0.1 Hz)	Setting range Factory setting: 50 Hz, or preset to 60 Hz if [Motor Standard] $b F r$ is set to [60 Hz] $b D$.

[Nominal Motor Speed] $n 5 P \star$

Nominal motor speed (related to the motor nameplate data).

This parameter can only be accessed with asynchronous motor control types.

NOTE: Modifying this parameter resets the motor tune parameters and, **[Tune Selection] 5 $\epsilon \mu n$** is reset to **[Default] $\epsilon R b$** . Autotuning will need to be performed again.

If the nameplate indicates the synchronous speed and the slip in Hz or as a %, use one of the formulas to calculate the rated speed:

- Nominal speed = Synchronous speed x $\frac{100 - \text{slip as a \%}}{100}$
- Nominal speed = Synchronous speed x $\frac{60 - \text{slip in Hz}}{60}$ (60 Hz motors)
- Nominal speed = Synchronous speed x $\frac{50 - \text{slip in Hz}}{50}$ (50 Hz motors).

Setting	Description
0...65,535 rpm (step: 1 rpm)	Setting range Factory setting: according to drive rating and [Motor Standard] $b F r$

[Motor Param Choice] $n P \epsilon \star$

Motor parameter choice.

This parameter selects which motor nameplate parameter is used between **[Motor 1 Cosinus Phi] $\epsilon \sigma 5$** and **[Nominal Motor Power] $n P r$** . Set the selected parameter, depending on this parameter setting.

This parameter can only be accessed with asynchronous motor control types.

NOTE: Modifying this parameter resets the motor tune parameters and, **[Tune Selection] 5 $\epsilon \mu n$** is reset to **[Default] $\epsilon R b$** . Autotuning will need to be performed again.

Setting	Code / Value	Description
[Mot Power]	$n P r$	Motor power: [Nominal Motor Power] $n P r$ is used. Factory setting
[Mot Cosinus]	$\epsilon \sigma 5$	Motor cosinus: [Motor 1 Cosinus Phi] $\epsilon \sigma 5$ is used.

[Motor 1 Cosinus Phi] $\epsilon \sigma 5 \star$

Nominal motor cosinus Phi (given on the motor nameplate).

This parameter can only be accessed with asynchronous motor control type and if **[Motor Param Choice] $\Pi P C$** is set to **[Mot Cosinus] $C o s$** .

NOTE: Modifying this parameter resets the motor tune parameters and, **[Tune Selection] $S t u n$** is reset to **[Default] $E R b$** . Autotuning will need to be performed again.

Setting	Description
0.50...1.00 (step: 0.01)	Setting range Factory setting: according to the drive rating

[AsyncMotor R Stator] $r S R$ ★

Asynchronous motor stator resistance.

The factory setting is replaced by a measure resulting from a standstill motor tune (autotuning) if it has been performed. Only enter manually a value if you are copying a drive configuration that has been tuned via autotuning.

This parameter can only be accessed with asynchronous motor control types and if **[Access Level] $L R C$** is set to **[Expert] $E P r$** .

Setting	Description
0...65,535 mOhm (step: 1 mOhm) ⁽¹⁾	Setting range Factory setting: 0 mOhm
⁽¹⁾ : For drives with power range ≤ 15 kW. If the power range is between 18 and 75 kW (limits included), the range is 0.0...6,553.5 mOhm (step: 0.1 mOhm). If the power range is between 90 and 500 kW (limits included), the range is 0.00...655.35 mOhm (step: 0.01 mOhm) else the range is 0.000...65.535 mOhm (step: 0.001 mOhm).	

[Magnetizing Current] $i d R$ ★

Magnetizing current.

The factory setting is replaced by the result of an internal calculation based on standstill motor tune results (autotuning).

This parameter can only be accessed with asynchronous motor control types and if **[Access Level] $L R C$** is set to **[Expert] $E P r$** .

This parameter impacts the setting of **[Nom Motor Torque] $t q n$** .

Setting	Description
0.00...655.35 A (step: 0.01 A) ⁽¹⁾	Setting range Factory setting: 0.00 A
⁽¹⁾ : For drives with power range ≤ 15 kW. If the power range is between 18 and 160 kW (limits included), the range is 0.0...6,553.5 A (step: 0.1 A) else the range is 0...65,535 A (step: 1 A).	

[AsyncMotor Lf Induct] $L F R$ ★

Asynchronous motor leakage inductance.

The factory setting is replaced by an measure resulting from a standstill motor tune (autotuning) if it has been performed. Only enter manually a value if you are copying a drive configuration that has been tuned via autotuning.

This parameter can only be accessed with asynchronous motor control types and if **[Access Level] $L R C$** is set to **[Expert] $E P r$** .

Setting	Description
0.00...655.35 mH (step: 0.01 mH) ⁽¹⁾	Setting range Factory setting: 0.00 mH
^{(1):} For drives with power range \leq 15 kW. If the power range is greater than 160 kW, the range is 0.0...6,553.5 μ H (step: 0.1 μ H) else the range is 0.00...65,535 μ H (step: 1 μ H).	

[Rotor Time Const] ϵ r R ★

Rotor time constant.

This parameter is the result of an internal calculation using motor nameplate parameters and motor autotuning results.

This parameter can only be accessed with asynchronous motor control types and if [Access Level] L R ϵ is set to [Expert] E P r .

Setting	Description
0.0...6,553.5 ms (step: 0.1 ms) ⁽¹⁾	Setting range Factory setting: 0.0 ms
^{(1):} For drives with power range \leq 15 kW else the range is 0...65,535 ms (step: 1 ms).	

[Sync Nominal I] n ϵ r 5 ★

Sync motor nominal current (given on the motor nameplate).

This parameter can only be accessed with synchronous or reluctance motor control types.

NOTE: Modifying this parameter resets the motor tune parameters and, [Tune Selection] 5 ϵ u n is reset to [Default] ϵ R b . Autotuning will need to be performed again.

Setting	Description
0.25...1.5 I _n ⁽¹⁾ (step: 0.01 A ⁽²⁾)	Setting range Factory setting: according to the drive rating.
^{(1):} Corresponding to the rated drive current indicated in the installation manual and on the drive nameplate. ^{(2):} For drives with power range \leq 15 kW. If the power range is between 18 and 160 kW (limits included), the step is 0.1 A else it is 1 A.	

[Nom SyncMotor Speed] n 5 P 5 ★

Nominal synchronous motor speed (given on the motor nameplate).

This parameter can only be accessed with synchronous or reluctance motor control types.

NOTE: Modifying this parameter resets the motor tune parameters and, [Tune Selection] 5 ϵ u n is reset to [Default] ϵ R b . Autotuning will need to be performed again.

Setting	Description
0...48,000 rpm (step: 1 rpm)	Setting range Factory setting: according to the drive rating.

[Torque scaling] *inr t*

Torque scaling.

This parameter shows the scaling of **[Motor torque (Nm)]** *o t 9 n*, **[Nom Motor Torque]** *t 9 n* and **[Nom Motor Torque]** *t 9 5*.

According to your needs, you can adjust the torque scaling multiplying by 10 the default torque unit.

Setting	Code / Value	Description
[0.001]	<i>0 0 0 1</i>	Unit: 0.001 Nm Absolute setting range: 0.001...65.535 Nm Setting range: -32.767...+32.767 Nm
[0.01]	<i>0 0 1</i>	Unit: 0.01 Nm Absolute setting range: 0.01...655.35 Nm Setting range: -327.67...+327.67 Nm
[0.1]	<i>0 1</i>	Unit: 0.1 Nm Absolute setting range: 0.1...6,553.5 Nm Setting range: -3,276.7...+3,276.7 Nm
[1]	<i>1</i>	Unit: 1 Nm Absolute setting range: 1...65,535 Nm Setting range: -32,767...+32,767 Nm
[10]	<i>1 0</i>	Unit: 10 Nm Absolute setting range: 10...655,350 Nm Setting range: -327,670...+327,670 Nm
NOTE: Factory setting: according to the drive rating		

[Nom Motor torque] *t 9 5*★

Nominal motor torque (given on the motor nameplate).

This parameter can only be accessed with synchronous or reluctance motor control types.

NOTE: Modifying this parameter resets the motor tune parameters and, **[Tune Selection]** *5 t u n* is reset to **[Default]** *t R b*. Autotuning will need to be performed again.

Setting	Description
0.1...6,553.5 Nm	Setting range according to drive ratings and [Torque Scaling] <i>inr t</i> setting. Factory setting: according to the drive rating.

[Pole pairs] *P P n 5*★

Pole pairs (given on the motor nameplate).

This parameter is used to calculate **[Sync Nominal Freq]** *F r 5 5*.

This parameter can only be accessed with synchronous or reluctance motor control types.

NOTE: Modifying this parameter resets the motor tune parameters and, **[Tune Selection]** *5 t u n* is reset to **[Default]** *t R b*. Autotuning will need to be performed again.

Setting	Description
1...240 (step: 1)	Setting range Factory setting: according to the drive rating.

[Angle setting type] $P 5 \mathcal{L} \star$

Automatic angle setting type.

This parameter can only be accessed with synchronous or reluctance motor control types.

This function is used to align the rotor or to compute the angle of the rotor flux linked to permanent magnets in order to reduce torque jolt at start-up.

Setting	Code / Value	Description
[PSI align]	$P 5 \mathcal{L}$	Pulse signal injection. Standard alignment mode, without rotor motion. The angle measurement is realized by monitoring the stator current response to a pulse signal injection over a wide range of frequencies.
[PSIO align]	$P 5 \mathcal{L} \sigma$	Pulse signal injection - optimized. Optimized alignment mode, without rotor motion. Same operation as [PSI align] $P 5 \mathcal{L}$, is performed over an optimized range of frequencies The measurement time is reduced after the first run order or tune operation, even if the drive has been turned off. Factory setting
[Rotational Current Injection]	$r \mathcal{L} \mathcal{L}$	Rotational current injection. Alignment mode with rotor motion. This alignment mode realizes the mechanical alignment of the rotor and the stator; it requires up to 4 s. The motor needs to be stopped and without resistive torque. NOTE: This setting is recommended when a sinus filter is used on the application. NOTE: For synchronous reluctance motor, it is recommended to use this setting.
[No align]	$n \sigma$	No alignment

[Syn. EMF constant] $P H 5 \star$

Synchronous motor EMF constant

$P H 5$ adjustment allows you to reduce the current in operation without load (or with minimum of load). To optimize the synchronous motor settings, follow the steps.

This parameter can only be accessed with synchronous motor control types.

Setting	Description
0...6,553.5 mV/rpm (step: 0.1 mV/rpm)	Setting range Factory setting: 0 mV/rpm

[SyncMotor Stator R] $r 5 P 5 \star$

Calculated SyncMotor Stator R (cold state stator resistance per winding).

The factory setting is replaced by an estimation resulting from a standstill motor tune (autotuning) if it has been performed. Only enter manually a value if you are copying a drive configuration that has been tuned via autotuning.

This parameter can only be accessed with synchronous or reluctance motor control types and if **[Access Level] L R C** is set to **[Expert] E P r**.

Setting	Description
0...65,535 mOhm (step: 1 mOhm) ⁽¹⁾	Setting range Factory setting: 0 mOhm
⁽¹⁾ : For drives with power range ≤ 15 kW. If the power range is between 18 and 75 kW (limits included), the range is 0.0...6,553.5 mOhm (step: 0.1 mOhm). If the power range is between 90 and 500 kW (limits included), the range is 0.00...655.35 mOhm (step: 0.01 mOhm) else the range is 0.000...65.535 mOhm (step: 0.001 mOhm).	

[Autotune L d-axis] L d 5 ★

Sync motor d inductance (axis "d" stator inductance per phase).

The factory setting is replaced by an estimation resulting from a standstill motor tune (autotuning) if it has been performed. Only enter manually a value if you are copying a drive configuration that has been tuned via autotuning.

NOTE: On motors with smooth poles, **[Autotune L d-axis] L d 5 = [Autotune L q-axis] L q 5 = Stator inductance L.**

This parameter can only be accessed with synchronous or reluctance motor control types and if **[Access Level] L R C** is set to **[Expert] E P r**.

Setting	Description
0.00...655.35 mH (step: 0.01 mH) ⁽¹⁾	Setting range Factory setting: 0.00 mH
⁽¹⁾ : For drives with power range ≤ 15 kW. If the power range is greater than 160 kW, the range is 0.0...6,553.5 μH (step: 0.1 μH) else the range is 0.00...65,535 μH (step: 1 μH).	

[Autotune L q-axis] L q 5 ★

Sync motor q inductance (axis "q" stator inductance per phase).

The factory setting is replaced by an estimation resulting from a standstill motor tune (autotuning) if it has been performed. Only enter manually a value if you are copying a drive configuration that has been tuned via autotuning.

NOTE: On motors with smooth poles, **[Autotune L d-axis] L d 5 = [Autotune L q-axis] L q 5 = Stator inductance L.**

This parameter can only be accessed with synchronous or reluctance motor control types and if **[Access Level] L R C** is set to **[Expert] E P r**.

Setting	Description
0.00...655.35 mH (step: 0.01 mH) ⁽¹⁾	Setting range Factory setting: 0.00 mH
⁽¹⁾ : For drives with power range ≤ 15 kW. If the power range is greater than 160 kW, the range is 0.0...6,553.5 μH (step: 0.1 μH) else the range is 0.00...65,535 μH (step: 1 μH).	

[Sync Nominal Freq] F r 5 5 ★

Synchronous motor nominal frequency.

This parameter can only be accessed with synchronous or reluctance motor control types and if [Access Level] $L R C$ is set to [Expert] $E P r$.

NOTE: Modifying this parameter resets the motor tune parameters and, [Tune Selection] $5 \epsilon u n$ is reset to [Default] $\epsilon R b$. Autotuning will need to be performed again.

Setting	Description
10.0...500.0 Hz (step: 0.1 Hz)	Setting range Factory setting: $n 5 P 5 \times P P n 5 / 60$ (the value is automatically updated and cannot be modified)

[PSI Align Curr Max] $\Pi C r \star$

Maximum current of PSI alignment.

Current level in % of [Sync Nominal I] $n C r 5$ for [PSI align] $P 5$, and [PSIO align] $P 5$, σ angle shift measurement modes. This parameter has an impact on the inductor measurement.

This parameter can only be accessed with synchronous or reluctance motor control types and if [Access Level] $L R C$ is set to [Expert] $E P r$.

This current must be equal to or higher than the maximum current level of the application; otherwise an instability may occur.

NOTE: In case of instability, [PSI Align Curr Max] $\Pi C r$ should be increased by steps up to obtain the requested performances.

Setting	Code / Value	Description
[Auto]	$R u t o$	[PSI Align Curr Max] $\Pi C r$ is adapted by the drive according to the motor data settings. Factory setting
1...300 % (step: 1 %)		setting range

[Current Filter Time] $C r \epsilon F \star$

Filter time of the current.

This parameter is defined the filter time of the feedback currents data internally used by the drive.

This parameter can be accessed if [Access Level] $L R C$ is set to [Expert] $E P r$.

Setting	Code / Value	Description
[Auto]	$R u t o$	Currents filter time applied is defined by [Currents Filter] $C r F R$. Factory setting
1...100.0 ms (step: 0.1 ms)		setting range

[Currents Filter] $C r F R \star$

Internal currents filter time.

Default currents filter time used if [Current Filter Time] $C r \epsilon F$ is set to [Auto] $R u t o$.

This parameter can be accessed if [Access Level] $L R C$ is set to [Expert] $E P r$.

Setting	Description
0.0...100.0 ms (step: 0.1 ms)	Setting range Factory setting: Read-only parameter.

[Ratio D-Axis error] r_{dRE} ★

Ratio D-axis current.

This parameter can only be accessed with synchronous motor control types and asynchronous motor control types.

This parameter is used to perform adjustments on **[Syn. EMF constant] P_{H5}** for synchronous motors and **[Magnetizing Current] i_{dR}** for asynchronous motors:

This parameter should be close to 0%. If **[Ratio D-Axis error] r_{dRE}** is:

- Lower than 0%:
 - **[Syn. EMF constant] P_{H5}** may be increased for synchronous motors.
 - **[Magnetizing Current] i_{dR}** may be reduced for asynchronous motors.
- Greater than 0%:
 - **[Syn. EMF constant] P_{H5}** may be reduced for synchronous motors.
 - **[Magnetizing Current] i_{dR}** may be increased for asynchronous motors.

For asynchronous motors, the value **[Ratio D-Axis error] r_{dRE}** may change according to the motor operating point. A value of **[Ratio D-Axis error] r_{dRE}** between -10% and 10% ensures good motor performance.

For the all steps to follow to optimize the synchronous motor settings.

For the all steps to follow to optimize the asynchronous motor settings.

Setting	Description
0.0...6,553.5 % (step: 0.1 %)	Setting range Factory setting: Read-only parameter

[Nom Motor Tq Scaling] t_{qnc}

Nominal motor torque reference.

This parameter allows to select the reference nominal torque.

This parameter can be accessed if **[Access Level] L_{AC}** is set to **[Expert] E_{Pr}** .

Setting	Code / Value	Description
[Expert]	opt_i	Optimized torque is the nominal electromagnetic torque computed based on the electrical parameters of the motor. Note: Selecting this setting allows a precise use of the load. Factory setting
[Nameplate]	n_{np}	Nameplate torque is the nominal mechanical torque calculated based on the nameplate data of the motor.

[Nom Motor torque] t_{qn} ★

Computed nominal motor torque (+/- 2% tolerance).

In case of synchronous motors, this parameter is impacted by a modification of **[Nom Motor torque] PH5**.

In case of asynchronous motors, this parameter is impacted by a modification of **[Magnetizing Current] idR** and the magnetic saturation parameters (i.e **[Flux curve coeff A] RLFR**, **[Flux curve coeff B] bEED**, **[Tangential Main Inductance] LDR**).

NOTE: A tune in rotation modifies the magnetic saturation parameters.

According to **[Nom Motor Tq Scaling] t9nL** setting, **[Nom Motor torque] t9n** parameter displays the value of the optimized torque **[Expert Motor Tq] t9no** or the nameplate torque **[Plate Nom Motor Tq] t9nP**.

Setting	Description
0...65,535	Setting range according to drive ratings and [Torque Scaling] inrL setting. Factory setting: Read only

[Expert Motor Tq] t9no★

Optimized nominal motor torque.

This parameter can be accessed if **[Access Level] LRL** is set to **[Expert] EPr**.

Setting	Description
0...65,535	Setting range according to drive ratings and [Torque Scaling] inrL setting. Factory setting: Read only

[Plate Nom Motor Tq] t9nP★

Nameplate nominal motor torque

This parameter can be accessed if **[Access Level] LRL** is set to **[Expert] EPr**.

Setting	Description
0...65,535	Setting range according to drive ratings and [Torque Scaling] inrL setting. Factory setting: Read only

[Motor tune] 7 5 5 - Menu

Access

[Complete settings] → [Motor parameters] → [Motor data] → [Motor tune]

About This Menu

This menu is used to perform motor autotuning (or standstill motor tuning).

The tune operation optimizes:

- The motor performances at low speed.
- The estimation of the motor torque.
- The accuracy of the estimation of the process values in sensorless operation and monitoring.

Before performing a motor autotuning

- The motor parameters must be set first. If a motor parameter is modified (or a parameter impacting a motor parameter setting), autotuning must be re-performed.
- The motor has to be stopped. Verify that the application does not make the motor turn during the tune operation.
- The motor must be at cold state: the motor thermal state has a significant influence on the tuning result.

Autotuning can be performed:

- manually on request by setting [Autotuning] 5 5 5 to [Apply Autotuning] 5 5 5,
- manually using the digital input or bit assigned to [Autotuning Assign] 5 5 5,
- automatically at drive power-up if [Automatic autotune] 5 5 5 is set to [Yes] 5 5 5.

[Autotuning] 5 5 5

⚠ WARNING

UNEXPECTED MOVEMENT

Autotuning moves the motor in order to tune the control loops.

- Only start the system if there are no persons or obstructions in the zone of operation.

Failure to follow these instructions can result in death, serious injury, or equipment damage.

During autotuning, noise development and oscillations of the system are normal.

⚠ WARNING

LOSS OF CONTROL

- If you modify the value of one or more motor parameters after having performed autotuning, the value of [Tune selection] STUN is reset to [Default] TAB and you must re-perform autotuning.

Failure to follow these instructions can result in death, serious injury, or equipment damage.

If [Motor control type] C E E is set to [Reluctance Motor] S r V C, the drive operates the mechanical alignment of the motor ([Angle setting type] A S E set to [Rotational Current Injection] r C i) prior to start the autotuning.

Autotuning is only performed if no stop command has been activated. If a "freewheel stop" or "fast stop" function has been assigned to a digital input, this input must be set to 1 (active at 0).

Autotuning takes priority over any run or prefluxing commands, which will be taken into account after the autotuning sequence.

If autotuning has detected an error, this parameter automatically switches back to [No action] n o and, the error response depends on the configuration of [Tuning Error Resp] E n L.

Autotuning may last for several seconds. Do not interrupt the process. Wait for the Graphic Display Terminal to change to [No action] n o.

To redo a motor tuning, wait that it is stopped and cold. Set first [Autotuning] E u n to [Erase Autotuning] C L r, then redo the motor tuning.

The use of the motor autotuning without doing a [Erase Autotuning] C L r first is used to get the thermal state estimation of the motor.

The cable length has an influence on the tune result. If the wiring is modified, it is necessary to redo the tune operation.

Setting ()	Code / Value	Description
[No action]	n o	Autotuning not in progress. Factory setting
[Apply Autotuning]	Y E S	Autotuning is performed immediately if possible, then the parameter automatically changes to [No action] n o. If the drive state does not allow the tune operation immediately, the parameter changes to [No] n o and the operation must be done again. NOTE: The motor parameters must be set before performing autotuning.
[Erase Autotuning]	C L r	The motor parameters measured by the autotuning function are reset. The default motor parameter values are used to control the motor. [Autotuning Status] E u S is set to [Not done] E A b.

[Autotuning Status] E u S

Autotuning status.

Read-only parameter. This parameter is not saved at drive power-off. It shows the autotuning status since the last power-on.

NOTE: To know about which are the values used by the drive to control the motor (e.g. if the values used are the results of an autotuning) refer to [Tune Selection] S E u n, page 160.

Setting	Code / Value	Description
[Not done]	E A b	The autotuning is not done Factory setting
[Pending]	P E n d	The autotuning has been requested but not yet performed
[In Progress]	P r o G	The autotuning is in progress
[Error]	F A i L	The autotuning has detected an error
[Done]	d o n E	The motor parameters measured by the autotuning function are used to control the motor

[Auto tuning usage] E U N U ★

Auto tune usage.

On some application, such as hoisting application, that requires high torque at low speed, the temperature of the motor has a significant influence on the behavior and the capability to maintain the optimization of the performance resulting from the autotuning. In such case, setting the parameter **[Autotuning Usage] TUNU** to **[Therm mot] TM** helps to compensate the stator resistance according to the thermal state of the motor.

⚠ WARNING**LOSS OF CONTROL**

- Set this parameter to **[Therm mot] TM** on hoisting application.
- For any setting of this parameter, perform a comprehensive commissioning test to verify correct operation of the application under maximum load and motor temperature conditions.

Failure to follow these instructions can result in death, serious injury, or equipment damage.

This parameter shows the way used to modify the motor parameters according to its estimated thermal state.

This parameter can be accessed if **[Access Level] L R C** is set to **[Expert] E P r**.

Setting ()	Code / Value	Description
[No]	n o	No thermal state estimation. Factory setting
[Therm Mot]	E n	Statoric thermal state estimation based on nominal current and current consumed by the motor. It helps to take into account the thermal deviation of the statoric resistor impacting the application response (especially with open loop application).

[Tuning Error Resp] E n L ★

Response to autotune error (**[Autotuning Error] E n F**).

This parameter can be accessed if **[Access Level] L R C** is set to **[Expert] E P r**.

Setting	Code / Value	Description
[Ignore]	n o	Detected error ignored.
[Freewheel Stop]	Y E S	A freewheel stop is requested and the error is triggered. Factory setting

[Autotuning Assign] E U L ★

Autotuning input assignment.

The autotuning is performed when the assigned input or bit changes to 1.

This parameter can be accessed if **[Access Level] L R C** is set to **[Expert] E P r**.

NOTE: The autotuning causes the motor to start up.

Setting	Code / Value	Description
[Not Assigned]	<i>n o</i>	Not assigned Factory setting
[DI1]...[DI6]	<i>L , 1...L , 6</i>	Digital input DI1...DI6
[DI11]...[DI16]	<i>L , 11... L , 16</i>	Digital input DI11...DI16 if VW3A3203 I/O extension module has been inserted
[CD00]... [CD10]	<i>C d 0 0... C d 1 0</i>	Virtual digital input CMD.0...CMD.10 in [I/O profile] , <i>o</i> configuration
[CD11]... [CD15]	<i>C d 1 1... C d 1 5</i>	Virtual digital input CMD.11...CMD.15 regardless of configuration
[C101]... [C110]	<i>C 1 0 1... C 1 1 0</i>	Virtual digital input CMD1.01...CMD1.10 with integrated Modbus Serial in [I/O profile] , <i>o</i> configuration
[C111]... [C115]	<i>C 1 1 1... C 1 1 5</i>	Virtual digital input CMD1.11...CMD1.15 with integrated Modbus Serial regardless of configuration
[C201]... [C210]	<i>C 2 0 1... C 2 1 0</i>	Virtual digital input CMD2.01...CMD2.10 with CANopen® fieldbus module in [I/O profile] , <i>o</i> configuration
[C211]... [C215]	<i>C 2 1 1... C 2 1 5</i>	Virtual digital input CMD2.11...CMD2.15 with CANopen® fieldbus module regardless of configuration
[C301]... [C310]	<i>C 3 0 1... C 3 1 0</i>	Virtual digital input CMD3.01...CMD3.10 with a fieldbus module in [I/O profile] , <i>o</i> configuration
[C311]... [C315]	<i>C 3 1 1... C 3 1 5</i>	Virtual digital input CMD3.11...CMD3.15 with a fieldbus module regardless of configuration
[C501]... [C510]	<i>C 5 0 1... C 5 1 0</i>	Virtual digital input CMD5.01...CMD5.10 with integrated Ethernet in [I/O profile] , <i>o</i> configuration
[C511]... [C515]	<i>C 5 1 1... C 5 1 5</i>	Virtual digital input CMD5.11...CMD5.15 with integrated Ethernet regardless of configuration

[Autotuning Type] *t u n t* ★

Autotuning type.

This parameter can be accessed:

- if **[Access Level]** *L A C* is set to **[Expert]** *E P r* , and
- with reluctance motor control type (**[Motor control type]** *C E E* set to **[Reluctance Motor]** *S r V C*).

Setting ()	Code / Value	Description
[Standard]	<i>S t d</i>	Standard autotune Factory setting
[Rotation]	<i>r o t</i>	Autotune in rotation. This selection can be used for: <ul style="list-style-type: none"> • Optimization of energy saving • Application with low inertia • Application that requires high motor control performances. With this selection, less than 30% of resistive load must be present on the application to optimize the autotuning result. During the autotune sequence, the motor will be started to half of its nominal frequency during maximum 45 seconds.

[Automatic autotune] *A u t* ★

Automatic autotune.

⚠ WARNING
<p>UNEXPECTED MOVEMENT</p> <p>If this function is activated, autotuning is performed each time the drive is switched on.</p> <ul style="list-style-type: none"> • Verify that activating this function does not result in unsafe conditions. <p>Failure to follow these instructions can result in death, serious injury, or equipment damage.</p>

The motor must be stopped when switching on the drive.

This parameter can be accessed if [Access Level] L A C is set to [Expert] E P r .

Setting ()	Code / Value	Description
[No]	n o	Function deactivated Factory setting
[Yes]	Y E S	A tuning is automatically done at each power-up

[Tune Selection] 5 E u n ★

Tune selection.

Read-only parameter.

Setting	Code / Value	Description
[Default]	E A b	The default motor parameter values are used to control the motor. Return to default value if a motor parameter is modified after autotuning has been performed. Factory setting
[Measure]	M E A S	The values measured by the autotuning function are used to control the motor. This parameter switches automatically to this value after an autotuning is successfully performed.
[Custom]	C u S	The values manually set are used to control the motor

[Saliency mot. state] 5 n o t ★

Information on synchronous motor saliency.

Read-only parameter (internally calculated).

This parameter can be accessed:

- if [Access Level] L A C is set to [Expert] E P r , and
- if [Tune Selection] 5 E u n is set to [Measure] M E A S , and
- with synchronous or reluctance motor control type.

This parameter helps the optimization of motor control performances for synchronous motors.

Setting	Code / Value	Description
[No]	n o	Tune not done
[Low salient]	L L S	Low saliency level. Recommended configuration: [Angle setting type] A S t = [PSI align] P S i , or [PSIO align] P S i o and [HF inj. activation] H F i = [No] n o .

Setting	Code / Value	Description
[Med salient]	$\Pi L 5$	Medium saliency level. Recommended configuration: [Angle setting type] $A 5 \epsilon =$ [SPM align] $S P \Pi R$. Additionally, [HF inj. activation] $H F i =$ [Yes] $Y E 5$ can be used. First, tests without high frequency injection must be performed. If the results meet the requirements, [HF inj. activation] $H F i$ must be let to [No] $n o$.
[High salient]	$H L 5$	High saliency level. Recommended configuration: [Angle setting type] $A 5 \epsilon =$ [IPM align] $i P \Pi R$. Additionally, [HF inj. activation] $H F i =$ [Yes] $Y E 5$ can be used. First, tests without high frequency injection must be performed. If the results meet the requirements, [HF inj. activation] $H F i$ must be let to [No] $n o$.

[Autotuning Lvl Of Current] $\epsilon \epsilon r$ ★

Tune current ratio.

This parameter can be accessed if [Access Level] $L A \epsilon$ is set to [Expert] $E P r$.

This parameter shows the level of current applied to the motor during auto tuning, in percent of the drive nominal current.

This parameter has an impact on the inductor measurement.

NOTE: In case of instability, [PSI Align Curr Max] $\Pi \epsilon r$ should be increased by steps up to obtain the requested performances.

Setting	Code / Value	Description
[Auto]	$A u \epsilon o$	Factory setting
1...300 % (step: 1 %)		setting range

[Angle setting type] $A 5 \epsilon$ ★

Automatic angle setting type.

This parameter can be accessed with synchronous or reluctance motor control type.

This function is used to align the rotor or to compute the angle of the rotor flux linked to permanent magnets in order to reduce torque jolt at start-up.

Setting	Code / Value	Description
[PSI align]	$P 5 i$	Pulse signal injection. Standard alignment mode, without rotor motion The angle measurement is realized by monitoring the stator current response to a pulse signal injection over a wide range of frequencies
[PSIO align]	$P 5 i o$	Pulse signal injection - optimized. Optimized alignment mode, without rotor motion Same operation as [PSI align] $P 5 i$ is performed over an optimized range of frequencies. The measurement time is reduced after the first run order or tune operation, even if the drive has been turned off. Factory setting

Setting	Code / Value	Description
[Rotational Current Injection]	$r \tau i$	Rotational current injection. Alignment mode with rotor motion. This alignment mode realizes the mechanical alignment of the rotor and the stator; it requires up to 4 s. The motor needs to be stopped and without resistive torque. NOTE: This setting is recommended when a sinus filter is used on the application. NOTE: For synchronous reluctance motor, it is recommended to use this setting.
[No align]	$n o$	No alignment

[PSI Align Curr Max] $\tau \tau r$ ★

Maximum current of PSI alignment.

Current level in % of [Sync Nominal I] $n \tau r$ s for [PSI align] $P 5 i$, and [PSIO align] $P 5 i o$ angle shift measurement modes. This parameter has an impact on the inductor measurement.

This parameter can only be accessed with synchronous or reluctance motor control types and if [Access Level] $L R \tau$ is set to [Expert] $E P r$.

This current must be equal to or higher than the maximum current level of the application; otherwise an instability may occur.

NOTE: In case of instability, [PSI Align Curr Max] $\tau \tau r$ should be increased by steps up to obtain the requested performances.

Setting	Code / Value	Description
[Auto]	$A u t o$	[PSI Align Curr Max] $\tau \tau r$ is adapted by the drive according to the motor data settings. Factory setting
1...300 % (step: 1 %)		setting range

[Rotational Current Level] $r \tau L$ ★

Rotational current level.

This parameter can be accessed if [Angle setting type] $R 5 E$ is set to [Rotational Current Injection] $r \tau i$.

The current level should be set according to the torque required during the alignment operation.

Setting	Description
10...300% (step: 1 %)	Setting range, as a percentage of the nominal motor current Factory setting: 75%

[Rotational Torque Current] $r \tau \tau$ ★

Rotational torque current.

This parameter can be accessed:

- if [Access Level] $L R \tau$ is set to [Expert] $E P r$, and
- if [Angle setting type] $R 5 E$ is set to [Rotational Current Injection] $r \tau i$, and
- with synchronous or reluctance motor control type.

Setting	Description
0...300% (step: 1 %)	Setting range, as a percentage of the nominal motor current Factory setting: 0%

[RCI Max Freq] $r C 5 P \star$

RCI maximum output frequency.

This parameter can be accessed:

- if **[Access Level]** $L R C$ is set to **[Expert]** $E P r$, and
- if **[Angle setting type]** $R 5 E$ is set to **[Rotational Current Injection]** $r C i$, and
- with synchronous or reluctance motor control type.

Setting	Code / Value	Description
[Auto]	$R u E o$	Factory setting
0.0...500.0 Hz (step: 0.1 Hz)		setting range

[RCI Round Nb] $r C r P \star$

RCI round number.

This parameter can be accessed:

- if **[Access Level]** $L R C$ is set to **[Expert]** $E P r$, and
- if **[Angle setting type]** $R 5 E$ is set to **[Rotational Current Injection]** $r C i$, and
- with synchronous or reluctance motor control type.

Setting	Code / Value	Description
[Auto]	$R u E o$	Factory setting
0...32,767 (step: 1)		setting range

[RCI With Transformer] $r C i r P \star$

RCI alignment with transformer.

This parameter can be accessed:

- if **[Access Level]** $L R C$ is set to **[Expert]** $E P r$, and
- if **[Angle setting type]** $R 5 E$ is set to **[Rotational Current Injection]** $r C i$, and
- with synchronous or reluctance motor control type.

Setting	Code / Value	Description
[No]	$n o$	Function inactive Factory setting
[Yes]	$y e s$	Function active

[Motor monitoring] $\Pi \square P$ - Menu

Access

[Complete settings] → [Motor parameters] → [Motor monitoring]

[Motor Th Current] I_{tH}

Motor thermal monitoring current to be set to the rated current indicated on the nameplate.

Setting (°)	Description
0.12...1.1 In ⁽¹⁾	Setting range Factory setting: According to drive rating
(1) Corresponding to the rated drive current indicated in the installation manual and on the drive nameplate.	

[Motor Thermal Mode] tHt

Motor thermal monitoring mode.

NOTE: An error is detected when the thermal state reaches 118% of the rated state and reactivation occurs when the state falls back below 100%.

Setting	Code / Value	Description
[No]	$n \square$	No thermal monitoring
[Self cooled]	$R \square L$	Self ventilated motor Factory setting
[Force-cool]	$F \square L$	Fan-cooled motor

[MotorTemp ErrorResp] $\square L L$

Overload error response.

Setting	Code / Value	Description
[Ignore]	$n \square$	Detected error ignored
[Freewheel Stop]	$Y \square S$	Free wheel Factory setting

[Thermal monitoring] P P - Menu

Access

[Complete settings] → [Motor parameters] → [Motor monitoring] → [Thermal monitoring]

About This Menu

The thermal monitoring function helps to prevent against high temperature by monitoring the real temperature by the drive.

PTC, PT100, PT1000, and KTY84 thermal probes are supported by this function.

The function gives the possibility to manage 2 levels of monitoring:

- A Warning level: the drive triggers an event without stopping the application.
- An Error level: the drive triggers an event and stops the application.

The thermal probe is monitored for the following detected error:

- Overheating
- Probe break (loss of signal)
- Probe short-circuit

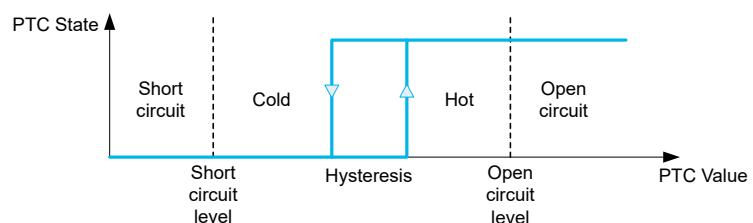

Activation

[Alx Th Monitoring] H X 5 allows you to activate the thermal monitoring on the related analog input:

- [No] n 0: the function is disabled
- [Yes] 4 E 5: the thermal monitoring is enabled on the related Alx.

Type of Thermal Probe Selection

[Alx Type] R , X E allows you to select the type of thermal sensor(s) connected on the related analog input:

- [No] n 0: no sensor
- [PTC Management] P E 0: one to six PTC (in serial) is used
- [KTY] K E 4: 1 KTY84 is used
- [PT100] I P E 2: 1 PT100 connected with two wires is used
- [PT1000] I P E 3: 1 PT1000 connected with two wires is used
- [PT100 in 3 wires] I P E 2 3: 1 PT100 connected with three wires is used (Al4 & Al5 only)
- [PT1000 in 3 wires] I P E 3 3: 1 PT1000 connected with three wires is used (Al4 & Al5 only)
- [3 PT100] 3 P E 2: 3 PT100 connected with two wires is used
- [3 PT1000] 3 P E 3: 3 PT1000 connected with two wires is used
- [3 PT100 in 3 wires] 3 P E 2 3: 3 PT100 connected with three wires is used (Al4 & Al5 only)

- **[3 PT1000 in 3 wires]** 3 P 5 3: 3 PT1000 connected with three wires is used (AI4 & AI5 only)

2-wire thermal probes are supported on analog input 2 to analog input 5.

3-wire thermal probes are supported on analog input 4 and analog input 5. These inputs are available with the I/O extension option module.

If the probe is far from the drive, the 3-wire connection is recommended as compared to a 2-wire connection.

NOTE: In case of 3 serial probes, the drive monitors the average probe values.

Wiring for PT100 and PT1000 Probes

For 2-wire probes, the following wirings are possible:

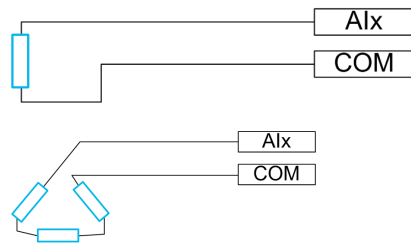

For 3-wire probes, the following wirings are possible:

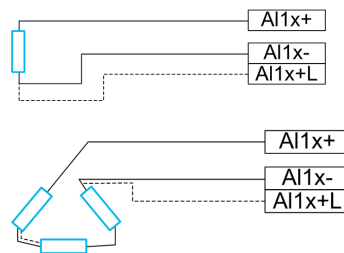

[AI2 Th Monitoring] 5 H 2 5

Activation of the thermal monitoring on AI2.

Setting	Code / Value	Description
[No]	n o	No Factory setting
[YES]	y e s	Yes

[AI2 Type] A , 2 5 ★

AI2 assignment.

This parameter can be accessed if [AI2 Th Monitoring] 5 H 2 5 is not set to [No] n o.

Setting	Code / Value	Description
[Voltage]	1 0 v	0-10 Vdc Factory setting
[Current]	0 A	0-20 mA
[PTC Management]	P 5 5	1 to 6 PTC (in serial)

Setting	Code / Value	Description
[KTY]	KTY	1 KTY84
[PT1000]	1PT3	1 PT1000 connected with 2 wires
[PT100]	1PT2	1 PT100 connected with 2 wires
[Water Prob]	LEEL	Water level
[3PT1000]	3PT3	3 PT1000 connected with 2 wires
[3PT100]	3PT2	3 PT100 connected with 2 wires

[AI2 Th Error Resp] 5 2 6★

Thermal monitoring response to a detected error for AI2.

This parameter can be accessed if [AI2 Type] 5 2 5 is not set to

- [Voltage] 100, or
- [Current] 00.

Setting	Code / Value	Description
[Ignore]	no	Detected error ignored
[Freewheel Stop]	YES	Freewheel stop
[Per STT]	5 5 5	Stop according to [Type of stop] 5 5 5 parameter but without an error triggered after stop
[Fallback Speed]	FFF	Change to fallback speed, maintained as long as the detected error persists and the command has not been removed ⁽¹⁾
[Ramp stop]	r PP	Stop on ramp Factory setting

[AI2 Th Error Level] 5 2 7★

Error detection level for AI2.

This parameter can be accessed if [AI2 Type] 5 2 5 is not set to:

- [Voltage] 100, or
- [Current] 00, or
- [PTC Management] 5 5 5.

Setting ()	Description
-15.0...200.0°C	Setting range Factory setting: 110.0°C

[AI2 Th Warn Level] 5 2 8★

Warning level for AI2.

This parameter can be accessed if [AI2 Type] 5 2 5 is not set to:

- [Voltage] 100, or
- [Current] 00, or
- [PTC Management] 5 5 5.

Setting ()	Description
-15.0...200.0°C	Setting range Factory setting: 90.0°C

[AI2 Th Value] 5 H 2 V ★

AI2 thermal value.

This parameter can be accessed if [AI2 Type] A , 2 5 is not set to:

- [Voltage] 1 0 4, or
- [Current] 0 A, or
- [PTC Management] P 5 5.

Setting	Description
-15.0...200.0°C	Setting range Factory setting: _

[AI3 Th Monitoring] 5 H 3 5

Activation of the thermal monitoring on AI3.

Setting	Code / Value	Description
[No]	n o	No Factory setting
[YES]	5 5 5	Yes

[AI3 Type] A , 3 5 ★

AI3 assignment.

This parameter can be accessed if [AI3 Th Monitoring] 5 H 3 5 is not set to [No] n o.

Identical to [AI2 Type] A , 2 5, page 166 with factory setting: [Current] 0 A.

[AI3 Th Error Resp] 5 H 3 6 ★

Thermal monitoring response to a detected error for AI3.

This parameter can be accessed if [AI3 Type] A , 3 5 is not set to:

- [Voltage] 1 0 4, or
- [Current] 0 A, or

Setting	Code / Value	Description
[Ignore]	n o	Detected error ignored
[Freewheel Stop]	5 5 5	Freewheel stop
[Per STT]	5 5 5	Stop according to [Type of stop] 5 5 5 parameter but without an error triggered after stop

Setting	Code / Value	Description
[Fallback Speed]	L F F	Change to fallback speed, maintained as long as the detected error persists and the command has not been removed ⁽¹⁾
[Ramp stop]	r P P	Stop on ramp Factory setting

[AI3 Th Error Level] 5 H 3 F ★

Error detection level for AI3.

This parameter can be accessed if [AI3 Type] R , 3 5 is not set to:

- [Voltage] I 0 0 , or
- [Current] 0 R , or
- [PTC Management] P 5 0 .

Setting ()	Description
-15.0...200.0°C	Setting range Factory setting: 110.0°C

[AI3 Th Warn Level] 5 H 3 R ★

Warning level for AI3.

This parameter can be accessed if [AI3 Type] R , 3 5 is not set to:

- [Voltage] I 0 0 , or
- [Current] 0 R , or
- [PTC Management] P 5 0 .

Setting ()	Description
-15.0...200.0°C	Setting range Factory setting: 90.0°C

[AI3 Th Value] 5 H 3 V ★

AI3 thermal value.

This parameter can be accessed if [AI3 Type] R , 3 5 is not set to:

- [Voltage] I 0 0 , or
- [Current] 0 R , or
- [PTC Management] P 5 0 .

Setting	Description
-15.0...200.0°C	Setting range Factory setting: _

[AI4 Th Monitoring] 5 H 4 5 ★

Activation of the thermal monitoring on AI4.

This parameter can be accessed if VW3A3203 I/O extension module has been inserted.

Setting	Code / Value	Description
[No]	n o	No Factory setting
[YES]	y e s	Yes

[AI4 Type] R , 4 E ★

AI4 assignment.

This parameter can be accessed if [AI4 Th Monitoring] 5 H 4 5 is not set to [No] n o .

Setting	Code / Value	Description
[Voltage]	1 0 v	0-10 Vdc
[Current]	0 A	0-20 mA
[Voltage +/-]	n 1 0 v	-10/+10 Vdc Factory setting

[AI4 Th Error Resp] 5 H 4 b ★

Thermal monitoring response to a detected error for AI4.

This parameter can be accessed if [AI4 Type] R , 4 E is not set to

- [Voltage] 1 0 v , or
- [Current] 0 A .

Setting	Code / Value	Description
[Ignore]	n o	Detected error ignored
[Freewheel Stop]	y e s	Freewheel stop
[Per STT]	5 e e	Stop according to [Type of stop] 5 e e parameter but without an error triggered after stop
[Fallback Speed]	L F F	Change to fallback speed, maintained as long as the detected error persists and the command has not been removed ⁽¹⁾
[Ramp stop]	r n p	Stop on ramp Factory setting

[AI4 Th Error Level] 5 H 4 F ★

Error detection level for AI4.

This parameter can be accessed if [AI4 Type] R , 4 E is not set to:

- [Voltage] 1 0 v , or
- [Current] 0 A , or
- [PTC Management] P e c .

Setting (°C)	Description
-15.0...200.0°C	Setting range Factory setting: 110.0°C

[AI4 Th Warn Level] 5 4 R★

Warning level for AI4.

This parameter can be accessed if [AI4 Type] R , 4 5 is not set to:

- [Voltage] 1 0 5, or
- [Current] 0 R, or
- [PTC Management] P 5 5 .

Setting ()	Description
-15.0...200.0°C	Setting range Factory setting: 90.0°C

[AI4 Th Value] 5 4 V★

AI4 thermal value.

This parameter can be accessed if [AI4 Type] R , 4 5 is not set to:

- [Voltage] 1 0 5, or
- [Current] 0 R, or
- [PTC Management] P 5 5 .

Setting	Description
-15.0...200.0°C	Setting range Factory setting: _

[AI5 Th Monitoring] 5 5 5★

Activation of the thermal monitoring on AI5.

This parameter can be accessed if VW3A3203 I/O extension module has been inserted.

Setting	Code / Value	Description
[No]	n o	No Factory setting
[YES]	y e s	Yes

[AI5 Type] R , 5 5★

AI5 assignment.

This parameter can be accessed if [AI5 Th Monitoring] 5 5 5 is not set to [No] n o.

Identical to [AI4 Type] R , 4 5 , page 170.

[AI5 Th Error Resp] 5 5 b★

Thermal monitoring response to a detected error for AI5.

This parameter can be accessed if [AI5 Type] R , 5 5 is not set to

- [Voltage] 1 0 5, or

- **[Current] D R**.

Setting	Code / Value	Description
[Ignore]	n o	Detected error ignored
[Freewheel Stop]	Y E S	Freewheel stop
[Per STT]	S E E	Stop according to [Type of stop] S E E parameter but without an error triggered after stop
[Fallback Speed]	L F F	Change to fallback speed, maintained as long as the detected error persists and the command has not been removed ⁽¹⁾
[Ramp stop]	r P P	Stop on ramp Factory setting

[AI5 Th Error Level] E H 5 F ★

Error detection level for AI5.

This parameter can be accessed if **[AI5 Type] R , S E** is not set to:

- **[Voltage] I D u**, or
- **[Current] D R**, or
- **[PTC Management] P E C**.

Setting (°)	Description
-15.0...200.0°C	Setting range Factory setting: 110.0°C

[AI5 Th Warn Level] E H 5 R ★

Warning level for AI5.

This parameter can be accessed if **[AI5 Type] R , S E** is not set to:

- **[Voltage] I D u**, or
- **[Current] D R**, or
- **[PTC Management] P E C**.

Setting (°)	Description
-15.0...200.0°C	Setting range Factory setting: 90.0°C

[AI5 Th Value] E H 5 V ★

AI5 thermal value.

This parameter can be accessed if **[AI5 Type] R , S E** is not set to:

- **[Voltage] I D u**, or
- **[Current] D R**, or
- **[PTC Management] P E C**.

Setting	Description
-15.0...200.0°C	Setting range Factory setting: _

[Fallback Speed] L F F

Fallback speed.

Setting	Description
0.0...500.0 Hz	Setting range Factory setting: 0.0 Hz

[Motor monitoring] Π \square P - Menu

Access

[Complete settings] \rightarrow [Motor parameters] \rightarrow [Motor monitoring]

About This Menu

The thermal monitoring function helps to prevent the motor from overheating by an estimation of the thermal state of the motor.

[Current Limitation] \llcorner L , \star

Internal current limit.

NOTICE

OVERHEATING

- Verify that the motor is properly rated for the maximum current to be applied to the motor.
- Consider the duty cycle of the motor and all factors of your application including derating requirements in determining the current limit.

Failure to follow these instructions can result in equipment damage.

NOTE: If the setting is less than $0.25 \cdot I_n$, the drive may lock in [OutPhaseLoss Assign] \square P L if this has been enabled. If it is less than the no-load motor current, the motor cannot run.

Setting ()	Description
0...1.5 I_n	Setting range
0...1.1 $I_n^{(1)}$	Factory setting: 1.1 $I_n^{(1)}$
(1) Corresponding to the rated drive current indicated in the installation manual and on the drive nameplate.	

[Attenuation Time] S \square P \star

Attenuation time.

This parameter can be accessed if [Motor surge limit.] S V L is not set to [No] \square \square .

The value of the [Volt surge limit. opt] S \square P parameter corresponds to the attenuation time of the cable used. It is defined to help to prevent the superimposition of voltage wave reflections resulting from long cable lengths. It limits over-voltages to twice the DC bus rated voltage.

As surge voltage depends on many parameters such as types of cable, different motor powers in parallel, different cable lengths in parallel, and so on, it is recommend the use of an oscilloscope to check the over-voltage values obtained at the motor terminals.

For long cable lengths, an output of the filter or a dV/dt filter must be used.

To retain the overall drive performance, do not increase the SOP value unnecessarily.

NOTE: The factory setting of this parameter is 10 μ s for ATV630C22N4 to ATV630C31N4.

Setting	Code / Value	Description
[6 μs]	5	6 μs
[8 μs]	8	8 μs Factory setting
[10 μs]	10	10 μs

[Sinus Filter Activation] 5 F 1 ★

Sinus filter activation.

This parameter can be accessed if **[Motor Control Type] 5 5 5** is not set to **[SYN_U VC] 5 5 5** and **[Reluctance Motor] 5 5 5**.

NOTICE		
DAMAGE TO THE SINUS FILTER		
Do not set the maximum output frequency [Max Frequency] TFR to a value greater than 100 Hz on systems with a sinus filter.		
Failure to follow these instructions can result in equipment damage.		

Setting	Code / Value	Description
[No]	no	No sinus filter Factory setting
[Yes]	YES	Use of a sinus filter to limit over-voltages on the motor and reduce the ground detected error leakage current or in case of applications with Step-Up transformer.
Optimized	Opt	Optimized. The reference switching frequency is not reduced in case of an overheating event. This selection can be accessed on ATV630●●●●●F, ATV650●●●●●F, ATV660, ATV680, ATV6A0, ATV6B0 and ATV60L0

[Output Short Circuit Test] 5 5 5

Output short circuit test configuration.

The drive outputs are tested at every power-up irrespective of the configuration of this parameter. If this parameter is set to **[Yes] YES**, the test is also done every time a run command is applied. These tests cause a slight delay (a few ms). In the event of an error, the drive locks.

The *drive output short-circuit (terminals U-V-W)*: SCF error can be detected.

The factory setting value is changed to **[Yes] YES** depending on the catalog numbers.

Setting	Code / Value	Description
[No]	no	Not test at run command Factory setting
[Yes]	YES	Output short circuit test at each run command

[Motor Therm Thd] 5 5 5

Motor thermal threshold for **[Motor Thermal Thd] 5 5 5** warning activation.

Setting ()	Description
0...118%	Setting range Factory setting: 100%

[Motor2 therm. level] 5 5 2

Motor 2 thermal level for [Motor2 Thermal Thd] 5 5 2 warning activation.

Setting ()	Description
0...118%	Setting range Factory setting: 100%

[Motor3 therm. level] 5 5 3

Motor 3 thermal level for [Motor3 Thermal Thd] 5 5 3 warning activation.

Setting ()	Description
0...118%	Setting range Factory setting: 100%

[Motor4 therm. level] 5 5 4

Motor 4 thermal level for [Motor4 Thermal Thd] 5 5 4 warning activation.

Setting ()	Description
0...118%	Setting range Factory setting: 100%

[Motor control] \llcorner \llcorner \llcorner - Menu

Access

[Complete settings] \rightarrow [Motor parameters] \rightarrow [Motor control]

About This Menu

This menu shows the motor control related parameters.

[IR compensation] \llcorner \llcorner \llcorner

This parameter is used to optimize torque at low speed, or to adapt to special cases (for example: for motors connected in parallel, decrease **[IR compensation] \llcorner \llcorner \llcorner**). If there is insufficient torque at low speed, increase **[IR compensation] \llcorner \llcorner \llcorner** . A too high value can avoid the motor to start (locking) or change the current limiting mode.

Setting ()	Description
0...200%	Setting range Factory setting: 100%

[Slip compensation] \llcorner \llcorner \llcorner ★

Slip compensation.

This parameter can be accessed if **[Motor Control Type] \llcorner \llcorner \llcorner** is not set to **[SYN_U VC] \llcorner \llcorner \llcorner** and **[Reluctance Motor] \llcorner \llcorner \llcorner** .

This parameter is set to 0% when **[Motor Control Type] \llcorner \llcorner \llcorner** is set to **[U/F VC Quad.] \llcorner \llcorner \llcorner** .

The speeds given on motor nameplates are not necessarily exact.

If the slip setting is lower than the actual slip, the motor is not rotating at the correct speed in steady state, but at a lower speed than the reference.

If the slip setting is higher than the actual slip, the motor is overcompensated and the speed is unstable.

Setting ()	Description
0...300%	Setting range Factory setting: 100%

[U/F Profile] \llcorner \llcorner \llcorner ★

U/F profile.

This parameter can be accessed if **[Motor Control Type] \llcorner \llcorner \llcorner** is set to **[U/F VC Quad.] \llcorner \llcorner \llcorner** .

This parameter is used to adjust the fluxing current level at zero speed, in % of nominal motor current at nominal speed.

Setting ()	Description
0...100%	Setting range Factory setting: 30%

[U1] U 1★ to [U5] U 5★

V/F profile setting.

Voltage point 1 on 5 points V/F to Voltage point 5 on 5 points V/F.

These parameters can be accessed if **[Motor Control Type] 5 5 5** is set to **[V/F 5pts] U F 5**.

Setting ()	Description
0...800 Vac	Setting range according to rating Factory setting: 0 Vac

[F1] F 1★ to [F5] F 5★

Frequency point 1 on 5 points V/F to Frequency point 5 on 5 points V/F.

V/F profile setting.

This parameter can be accessed if **[Motor Control Type] 5 5 5** is set to **[V/F 5pts] U F 5**.

Setting ()	Description
0.0...500.0 Hz	Setting range Factory setting: 0.0 Hz

[Output Ph Rotation] P H r

Output phase rotation.

Modifying this parameter operates as an inversion of 2 of the three motor phases. This results in changing the direction of rotation of the motor.

Setting	Code / Value	Description
[ABC]	<i>A b C</i>	Standard rotation Factory setting
[ACB]	<i>A C b</i>	Opposite rotation

[Inertia Factor] S P G U★

Inertia factor

This parameter can be accessed if:

- **[Access Level] L R C** is set to **[Expert] E P r**, and
- **[Motor Control Type] 5 5 5** is set to:
 - **[U/F VC 5pts] U F 5**, or
 - **[U/F VC Quad.] U F 9**, or
 - **[SYN_U VC] 5 9 n u**.

Setting ()	Description
1...1,000%	Setting range Factory setting: 40%

[Boost Activation] b o A★

Boost activation.

This parameter can be accessed if [Access Level] L R C is set to [Expert] E P r .

The factory setting of this parameter is modified to:

- [Inactive] n o if [Motor Control Type] C E E is set to [Reluctance Motor] S r V C .
- [Constant] C S E E if [Motor Control Type] C E E is set to [SYN_U VC] S Y n u .

Setting	Code / Value	Description
[Inactive]	n o	No boost
[Dynamic]	d Y n A	Dynamic boost, the magnetizing current value is modified according to the motor load. Factory setting NOTE: Drive manages itself the value [Magnetizing Current] i d A to optimize the performances. NOTE: This selection can't be accessed if [Motor Control Type] C E E is set to [Reluctance Motor] S r V C or [SYN_U VC] S Y n u .
[Static]	S E A E	Static boost, the magnetizing current value follows the profile whatever the motor load NOTE: With this selection the [Boost] b o o and [Freq Boost] F A b are taken into account. NOTE: This selection can be used for conical motor with [Boost] b o o sets to a negative value.
[Constant]	C S E E	Constant boost, the magnetizing current is maintained in case of change of direction of the motor. An additional parameter is available to handle the deceleration and stop phase. C S E E can be accessed if [Motor Control Type] C E E is set to [Reluctance Motor] S r V C or [SYN_U VC] S Y n u . NOTE: With this selection only [Boost] b o o is taken into account.

[Boost] b o o★

Value at 0 Hz: % of nominal magnetizing current (taken into account if different from 0).

A too high value of [Boost] b o o can result in a magnetic saturation of the motor, which leads to a torque reduction.

This parameter can be accessed if:

- [Access Level] L R C is set to [Expert] E P r , and
- [Boost Activation] b o A is not set to [Inactive] n o .

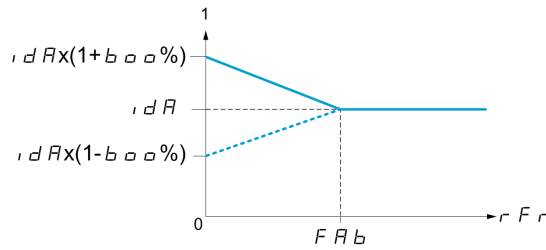

NOTE: For synchronous motors, it is recommended to set this value to optimize control at low speed.

Setting	Description
-100...100%	Setting range If [Boost Activation] b_o A is set to [Dynamic] d Y n A , [Boost] b_o o is set to 25%. Factory setting: 0%

[Freq Boost] F_R b ★

Value at 0 Hz: speed threshold to reach nominal magnetizing current.

This parameter can be accessed if:

- **[Access Level] L_R C** is set to **[Expert] E P r**, and
- **[Boost Activation] b_o A** is not set to **[NO] n o**, and
- **[Boost Activation] b_o A** is not set to **[Constant] C 5 E E**.

Setting	Description
0.0...500.0 Hz	Setting range If [Boost Activation] b_o A is set to [Dynamic] d Y n A , [Freq Boost] F_R b is set to 30.0 Hz. Factory setting: 0.0 Hz

NOTE: For synchronous motors, it is recommended to set this value to optimize control at low speed.

[Spd Loop Optimization] P C L - Menu

Access

[Complete settings] → [Motor parameters] → [Motor control] → [Spd Loop Optimization]

About This Menu

This procedure can be done if [Motor control type] C E E is not set to [U/F VC Standard] S E d, [U/F VC Quad.] u F 9, [U/F VC 5pts] u F 5 or [SYN_U VC] S Y n u.

Recommended Procedure for Setting the High-Performance Speed Loop

Step	Action
1	Enter the motor parameters. If you subsequently modify one of these, you have to perform this whole procedure again.
2	The value of the inertia being driven must be entered in the [Application Inertia] J R P L parameter. , page 188 NOTE: If a motor parameter is modified, the estimated inertia is recalculated and updated (parameters [Estim. app. inertia] J E S E and [Inertia Mult. Coef.] J P u L . [Application Inertia] J R P L returns to its default value according to the new value of [Estim. app. inertia] J E S E .
3	Check the speed loop response time by first setting [Feed forward] F F P to 0 (see graphs on next page).
4	If necessary, adjust the bandwidth and stability using parameters [FreqLoop Stab] S E R and [FreqLoopGain] F L G , page 184.
5	To optimize ramp following, increase the feedforward parameter [[Feed forward] F F P as indicated on the next page until the best result is obtained.
6	The feedforward term bandwidth can be adjusted if necessary (as shown on the next page) to further improve the ramp following or to filter the noise on the speed reference.

High-Performance speed Loop - Setting the [Feed forward] F F P Parameter

This is used to adjust the level of dynamic torque feedforward required for accelerating and decelerating the inertia. The effect of this parameter on ramp following is illustrated below. Increasing the value of F F P allows the ramp to be followed more closely. However, if the value is too high, overspeed occurs. The optimum setting is obtained when the speed follows the ramp precisely; this depends on the accuracy of the [Application Inertia] J R P L parameter, , page 188.

F F P settings

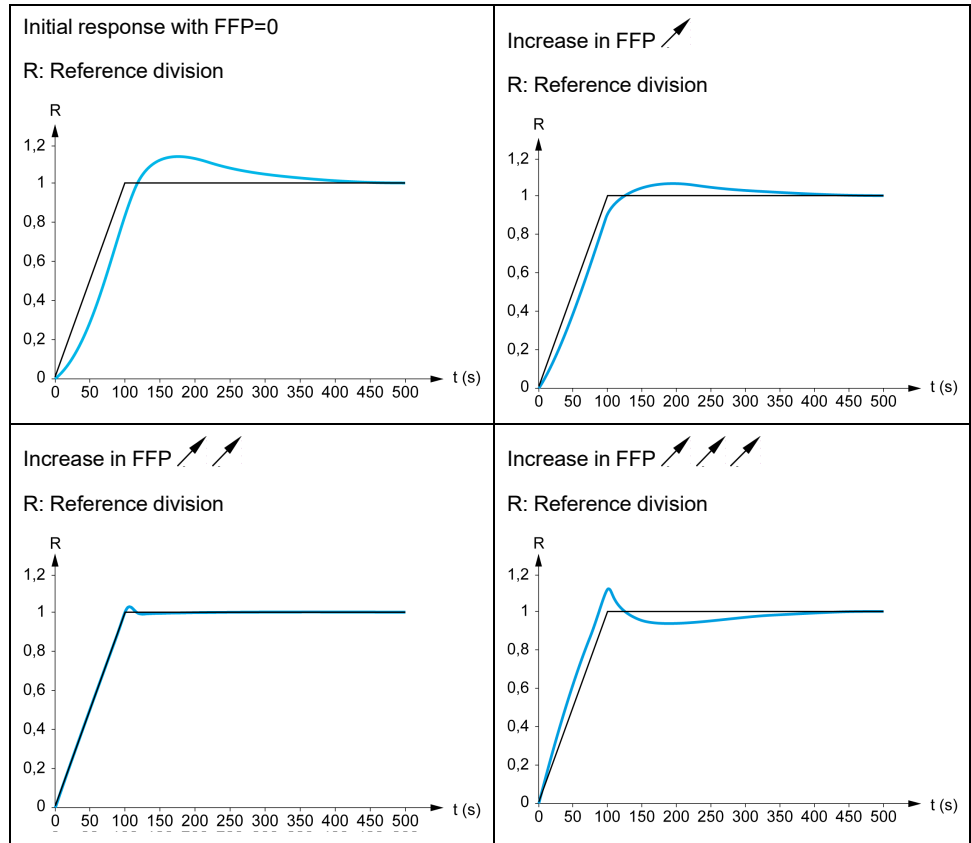

High-Performance Speed Loop - Setting the [FeedFwd Bandwidth] $F F V$ Parameter

This is used to adjust the bandwidth of the dynamic torque feedforward term. The effect of this parameter on ramp following is illustrated below. Decreasing the value of $F F V$ reduces the effect of noise on the speed reference (torque ripple). However, too great a decrease in relation to the ramp settings (on short ramps) causes a delay, and ramp following is adversely affected. Increasing the value of $F F V$ allows the ramp to be followed more closely, but also heightens noise sensitivity. The optimum setting is obtained by reaching the best compromise between ramp following and the existing noise sensitivity.

$F F V$ settings

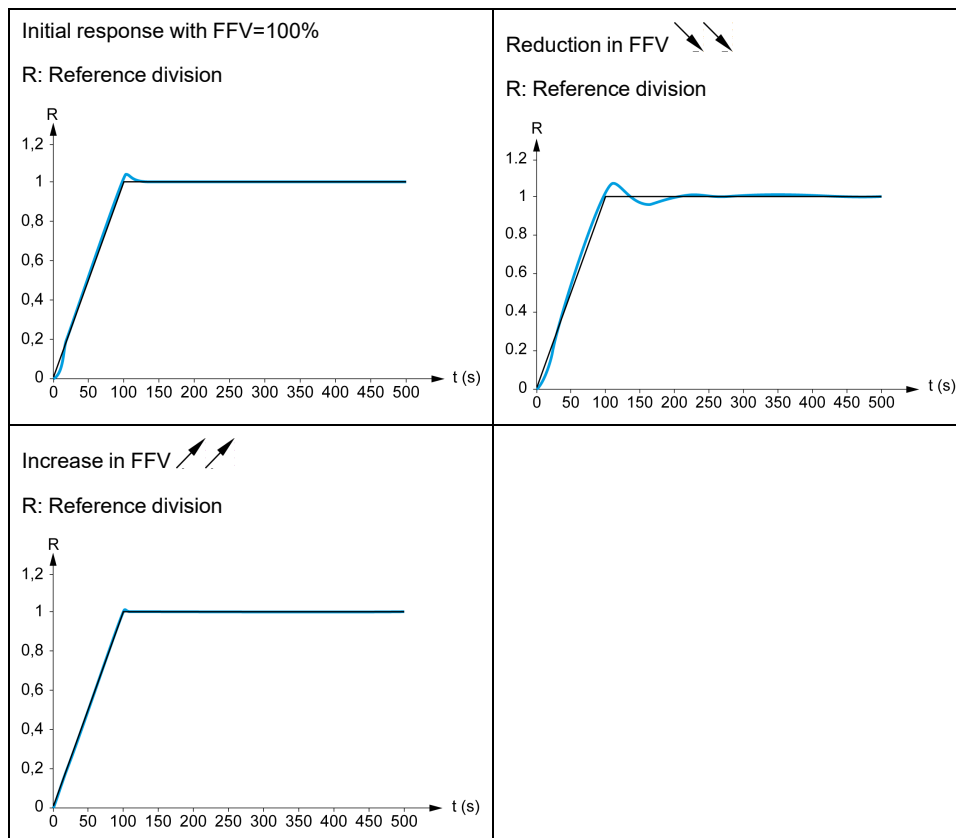

[Speed loop type] 5 5 L ★

Speed loop type.

This parameter can be accessed if [Motor control type] 5 5 L is not set to:

- [U/F VC Standard] 5 5 d, and
- [U/F VC Quad.] 5 5 q, and
- [U/F VC 5pts] 5 5 s, and
- [SYN_U VC] 5 5 n u

Setting	Code / Value	Description
[Standard]	5 5 d	Standard speed loop Factory setting
[High Perf]	H P F	High-performance speed loop. It is advised to deactivate [Dec. Ramp Adapt] b r A = [No] n o

[Speed prop. gain] 5 P G ★

Speed loop proportional gain.

This parameter can be accessed if:

- [Speed loop type] 5 5 L is set to [Standard] 5 5 d, and
- [Motor control type] 5 5 L is not set to:
 - [U/F VC Standard] 5 5 d, and
 - [U/F VC Quad.] 5 5 q, and
 - [U/F VC 5pts] 5 5 s, and
 - [SYN_U VC] 5 5 n u

Setting ()	Description
0...1,000%	Setting range Factory setting: 40%

[Speed time integral] S I E ★

Speed loop integral time constant.

This parameter can be accessed if:

- **[Speed loop type] S S L** is set to **[Standard] S E d**, and
- **[Motor control type] C E E** is not set to:
 - **[U/F VC Standard] S E d**, and
 - **[U/F VC Quad.] u F 9**, and
 - **[U/F VC 5pts] u F 5**, and
 - **[SYN_U VC] S Y n u**

Setting ()	Description
1...65,535 ms	Setting range Factory setting: According to the drive rating.

[K speed loop filter] S F C

Speed filter coefficient (0(IP) to 1(PI)).

Setting ()	Description
0...100	Setting range Factory setting: 65

[Spd est. filter time] F F H ★

Filter time of the estimated speed.

This parameter can be accessed if **[Access Level] L R C** is set to **[Expert] E P r**.

Setting ()	Description
0.0...100.0 ms	Setting range Factory setting: According to the drive rating

[FreqLoop Stab] S E R ★

Frequency loop stability (Speed loop damping factor).

This parameter can be accessed if:

- **[Speed loop type] S S L** is set to **[High Perf] H P F**, and

- **[Motor control type] C E E** is not set to:
 - **[U/F VC Standard] S E d**, and
 - **[U/F VC Quad.] u F 9**, and
 - **[U/F VC 5pts] u F 5**, and
 - **[SYN_U VC] S Y n u**

Stability: Used to adapt the return to steady state after a speed transient, according to the dynamics of the machine. Gradually increase the stability to increase control loop attenuation and thus reduce any overspeed.

Setting ()	Description
0...100%	Setting range Factory setting: 20%

[FreqLoopGain] F L G★

Frequency loop gain (Speed loop bandwidth).

This parameter can be accessed if:

- **[Speed loop type] S S L** is set to **[High Perf] H P F**, and
- **[Motor control type] C E E** is not set to:
 - **[U/F VC Standard] S E d**, and
 - **[U/F VC Quad.] u F 9**, and
 - **[U/F VC 5pts] u F 5**, and
 - **[SYN_U VC] S Y n u**

Used to adapt the response of the machine speed transients according to the dynamics. For machines with high resistive torque, high inertia of fast cycles, increase the gain gradually.

Setting ()	Description
0...100%	Setting range Factory setting: 20%

[Feed forward] F F P★

Feed-Forward term activation and setting.

This parameter can be accessed if:

- **[Speed loop type] S S L** is set to **[High Perf] H P F**, and
- **[Motor control type] C E E** is not set to:
 - **[U/F VC Standard] S E d**, and
 - **[U/F VC Quad.] u F 9**, and
 - **[U/F VC 5pts] u F 5**, and
 - **[SYN_U VC] S Y n u**

Percentages of the high-performance regulator feedforward term. 100% corresponds to the term calculated using the value of **[Application Inertia] J A P L**.

Setting ()	Description
0...200%	Setting range Factory setting: 0%

[FeedFwd Bandwidth] F F V ★

Bandwidth of the filter of feed-forward term.

This parameter can be accessed if:

- **[Speed loop type] 5 5 L** is set to **[High Perf] H P F**, and
- **[Motor control type] 5 5 5** is not set to:
 - **[U/F VC Standard] 5 5 5**, and
 - **[U/F VC Quad.] 5 5 5**, and
 - **[U/F VC 5pts] 5 5 5**, and
 - **[SYN_U VC] 5 5 5**

Bandwidths of the high-performance speed loop feedforward term, as a percentage of the predefined value.

Setting (°)	Description
20...500%	Setting range Factory setting: 100%

[External FeedFwd Assign] 5 5 F F ★

External feed-forward mode

Setting	Code / Value	Description
[No]	n o	Analog input is not assigned Factory setting
[AI1]...[AI3]	A 1 , 1 ... A 1 , 3	Analog input AI1...AI3
[AI4]...[AI5]	A 1 , 4 ... A 1 , 5	Analog input AI4...AI5 if VW3A3203 I/O extension module has been inserted
[Ref.Freq-Rmt.Term]	L C C	Reference Frequency via remote terminal
[Ref. Freq-Modbus]	M o d b	Reference frequency via Modbus
[Ref. Freq-CANopen]	C A n	Reference frequency via CANopen if a CANopen module has been inserted
[Ref. Freq-Com. Module]	n e t	Reference frequency via fieldbus module if a fieldbus module has been inserted
[Embedded Ethernet]	E t h	Embedded Ethernet
[DI5 PulseInput Assignment]...[DI6 PulseInput Assignment]	P 1 5 ... P 1 6	Digital input DI5...DI6 used as pulse input

[Inertia Mult. Coef.] J M L ★

Scaling factor for inertia displays.

This parameter can be accessed if:

- **[Speed loop type] 5 5 L** is set to **[High Perf] H P F**, and

- **[Motor control type] C E E** is not set to:
 - **[U/F VC Standard] S E d**, and
 - **[U/F VC Quad.] U F 9**, and
 - **[U/F VC 5pts] U F 5**, and
 - **[SYN_U VC] S Y n u**

Increment for **[Application Inertia] J A P L** and **[Estim. app. inertia] J E S E** parameters, calculated by the drive, in read-only mode: 0.1 gm², 1 gm², 10 gm², 100 gm², 1000 gm².

Setting	Description
0.0...6553.5 gm ²	Setting range Factory setting: 0.0 gm ²

[Estim. app. inertia] J E S E ★

Estimated application inertia.

This parameter can be accessed if:

- **[Speed loop type] S S L** is set to **[High Perf] H P F**, and
- **[Motor control type] C E E** is not set to:
 - **[U/F VC Standard] S E d**, and
 - **[U/F VC Quad.] U F 9**, and
 - **[U/F VC 5pts] U F 5**, and
 - **[SYN_U VC] S Y n u**

The inertia being driven is estimated by the drive according to the motor parameters, in read-only mode. Speed loop default settings are determined by the drive from this inertia.

Increment given by **[Inertia Mult. Coef.] J P u L**: - 0.1 gm², 1 gm², 10 gm², 100 gm² or 1000 gm².

Setting	Description
1...9,999 kg.m ²	Setting range Factory setting: -

[App. Inertia Coef.] J A C o ★

Adjustable application inertia ratio.

This parameter can be accessed if:

- **[Speed loop type] S S L** is set to **[High Perf] H P F**, and
- **[Motor control type] C E E** is not set to:
 - **[U/F VC Standard] S E d**, and
 - **[U/F VC Quad.] U F 9**, and
 - **[U/F VC 5pts] U F 5**, and
 - **[SYN_U VC] S Y n u**

Coefficient which fixes the ratio between **[Estim. app. inertia] J E S E** and **[Application Inertia] J A P L** parameters.

[Application Inertia] J A P L = [Estim. app. inertia] J E S E × [App. Inertia Coef.] J A C o.

Setting	Description
0.10...100.00	Setting range Factory setting: 1

[Application Inertia] J A P L ★

Adjustable application inertia.

This parameter can be accessed if:

- [Speed loop type] S S L is set to [High Perf] H P F , and
- [Motor control type] C E E is not set to:
 - [U/F VC Standard] S E d , and
 - [U/F VC Quad.] u F q , and
 - [U/F VC 5pts] u F 5 , and
 - [SYN_U VC] S Y n u

Adjustable application inertia used by the drive to optimize speed loop settings).

Increment given by [Inertia Mult. Coef.] J n u L : 0.1 gm², 1 gm², 10 gm², 100 gm² or 1000 gm².

NOTE: If a motor parameter is modified, the estimated inertia is recalculated and updated (parameters [Estim. app. inertia] J E S E and [Inertia Mult. Coef.] J n u L). [Application Inertia] J A P L is also returned to its default value according to the new value of [Estim. app. inertia] J E S E .

Setting	Description
0.00...655.35 kgm ²	Setting range Factory setting: -

[Motor control] \llcorner r \llcorner - Menu

Access

[Complete settings] \rightarrow [Motor parameters] \rightarrow [Motor control]

About This Menu

This menu shows the motor control related parameters.

About Output Voltage Management and Overmodulation

[Overmodul. Activation] \llcorner v \llcorner Π Π

Overmodulation activation.

This parameter can be accessed if [Access Level] \llcorner Π \llcorner is set to [Expert] \llcorner Π \llcorner .

The purpose of the overmodulation is to:

- compensate the voltage loss in DC bus when the drive is loaded.
- increase the maximum possible voltage to reduce current consumption at high motor voltage and limit thermal effect on the motor.

In factory settings, the motor supplied by the intermediate of the drive has:

- a common output voltage mode not null depending on the DC bus supply.
- No overmodulation ([Overmodul. Activation] \llcorner v \llcorner Π Π is set to [No] \llcorner Π \llcorner): sinusoidal phase to phase voltage.
- output voltage limited to the maximum possible value depending on DC bus supply which depends on the main power supply.

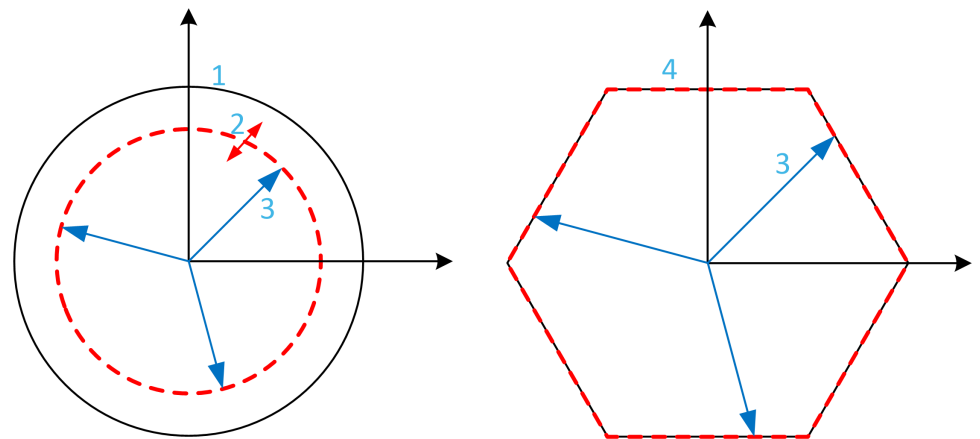

1 Maximum possible value of Output voltage limitation (default value)

2 VLim with numeric value under the maximum limitation

3 Output voltage

4 Output voltage limitation with full overmodulation (hexagon form)

Setting	Code / Value	Description
[Default]	<i>d E F R u L t</i>	Overmodulation is not configured By default, the Output voltage limitation describes a circle with at maximum radius depending of DC bus voltage. The radius can be reduced to a lower value by setting a numerical value to [Output voltage limitation] V L , n . Factory setting
[Full]	<i>F u L L</i>	Overmodulation is active and full. The output voltage limitation describes a regular hexagon depending of DC bus voltage. The phase to phase voltages are not sinusoidal.

[Output voltage limitation] V L , n

Output voltage limitation.

This parameter can be accessed if **[Access Level] L R C** is set to **[Expert] E P r**.

The purpose of this parameter is to modify the output voltage limitation to a lower value than the maximum default value.

The unit of the numerical value of this parameter is in phase to phase rms voltage.

This parameter cannot be set to a numerical value if **[Overmodul. Activation] o V n A** is set to **[FULL] F u L L**.

Setting	Code / Value	Description
[Default]	<i>d E F R u L t</i>	Default value of Output Voltage limitation. The Output Voltage limitation is at the maximum capability of the DC bus voltage depending on [Overmodul. Activation] o V n A setting. Factory setting
0...9999 V		Setting range of the output limitation voltage. Set a value lower than the corresponding [Default] d E F R u L t value to reduce the maximum output voltage limitation. If the numerical value is higher than the corresponding [Default] d E F R u L t value, this corresponding value is considered.

[Switching frequency] *5 W F - Menu*

Access

[Complete settings] → [Motor parameters] → [Switching frequency]

[Switching frequency] *5 F r*

Drive switching frequency.

Adjustment range: The maximum value is limited to 4 kHz if [Motor surge limit.] *5 V L* parameter is configured. The maximum value is limited to 4.9 kHz with *ATV•L0*.

If [Sinus Filter Activation] *5 F i* is set to [Yes] *5 E 5*, the minimum value is 1 kHz and the maximum value is limited to 6 kHz or 8 kHz according to drive rating.

NOTE: In the event of excessive temperature rise, the drive automatically reduces the switching frequency and reset it once the temperature returns to normal.

In case of high-speed motor, it is advised to increase the PWM frequency [Switching frequency] *5 F r* at 8, 12 kHz or 16 kHz

Setting ()	Description
1...8 or 16 kHz according to drive rating	Setting range Factory setting: 4.0 kHz or 2.5 kHz according to the drive rating When [Sinus Filter Activation] <i>5 F i</i> is set to [optimized] <i>5 P L i</i> , factory setting: 3.0 kHz or 2.5 kHz according to the drive rating

[Noise Reduction] *n r d*

Motor noise reduction.

Random frequency modulation helps to prevent any resonance, which may occur at a fixed frequency.

Setting	Code / Value	Description
[No]	<i>n o</i>	Fixed PWM frequency Factory setting
[Yes]	<i>5 E 5</i>	PWM Frequency with random modulation

[Switch Freq Type] *5 F L ★*

Switching frequency type.

This parameter can be accessed if [Access Level] *L R L* is set to [Expert] *E P r*.

The motor switching frequency is modified (reduced) when the internal temperature of the drive is too high.

Setting ()	Code / Value	Description
[SFR type 1]	H F 1	Heating loss optimization Allows the system to adapt the switching frequency according to the motor frequency. This setting optimizes the heating loss of the drive in order to improve the drive efficiency. Factory setting
[SFR type 2]	H F 2	Allows the system to keep a constant chosen switching frequency [Switching frequency] S F r whatever the motor frequency [Output frequency] r F r . With this setting, the motor noise is kept as low as possible by a high switching frequency. In the event of overheating, the drive automatically decreases the switching frequency. It is restored to its original value when the temperature returns to normal.

[Motor Surge Limit.] 5 V L

Surge voltage limitation.

This parameter is forced to **[No]** n o if **[Sinus Filter Activation]** o F i is set to **[Yes]** y E 5.

This function limits motor over-voltages and is useful in the following applications:

- NEMA motors
- Old or poor quality motors
- Spindle motors
- Rewound motors

This parameter can remain set to **[No]** n o for 230/400 Vac motors used at 230 Vac, or if the length of cable between the drive and the motor does not exceed:

- 4 m with unshielded cables
- 10 m with shielded cables

Setting	Code / Value	Description
[No]	n o	Function inactive Factory setting
[Yes]	y E 5	Function active NOTE: With this setting, the maximum of [Switching freq.] S F r is modified.

[Attenuation Time] 5 o P★

Attenuation time.

This parameter can be accessed if **[Motor surge limit.]** 5 V L is set to **[Yes]** y E 5.

The value of the **[Attenuation Time]** 5 o P parameter corresponds to the attenuation time of the cable used. It is defined to help to prevent the superimposition of voltage wave reflections resulting from long cable lengths. It limits over-voltages to twice the DC bus rated voltage. As surge voltage depends on many parameters such as types of cable, different motor powers in parallel, different cable lengths in parallel, and so on. It is recommended to use an oscilloscope to check the over-voltage values obtained at the motor terminals. If the higher value of **[Attenuation Time]** 5 o P is not enough according to the cable lengths, an output filter or a dV/dt filter must be used.

To retain the overall drive performance, do not increase the $S_{\alpha P}$ value unnecessarily.

Setting	Code / Value	Description
[6 μ s]	6	6 μ s
[8 μ s]	8	8 μ s Factory setting
[10 μ s]	10	10 μ s

[Input Filter] d C r - Menu

Access

[Complete settings] → [Motor parameters] → [Input Filter]

About This Menu

This menu cannot be accessed on ATV●80 and ATV●B0.

This function monitors the ripple on the DC bus by detecting instabilities. It is not used to detect input phase loss.

On the DC bus, if the oscillation frequencies are inconsistent with those observed on the mains supply, and if the amplitude is inconsistent with the drive capability (such as the DC bus capacitors), the drive triggers **[DC Bus Ripple Warn] d C r W** warning.

Depending on the setting of **[DC Bus Ripple Config] d C r C**, if **[DC Bus Ripple Warn] d C r W** warning is persistent during an amount of time set by an internal fixed value, **[DC Bus Ripple Error] d C r E** error is triggered.

[Input Filter] , F ,

Use of an input filter.

This parameter is forced to **[No] n o** if:

- **[Motor Control Type] C E E** is set to a value different from **[U/F VC Standard] 5 E d** and **[U/F VC 5pts] u F 5**, or
- **[Motor Control Type] C E E** is set to **[U/F VC 5pts] u F 5**, and
 - **[U1] u 1** or ... or **[U5] u 5** is configured, or
 - **[F1] F 1** or ... or **[F5] F 5** is configured.

Setting	Code / Value	Description
[No]	n o	No input filter used. Factory setting
[Yes]	y e s	Motor control performance is adjusted to consider the use of an input filter in order to help to prevent ripple on the DC bus.

[DC Bus Ripple Config] d C r C

Configuration of the DC bus ripple monitoring.

This parameter is preset to **[Error] F L E**, if **[Input Filter] , F ,** is set to **[Yes] y e s**.

Setting	Code / Value	Description
[Ignore]	n o	DC bus ripple monitoring function is inactive. This selection can't be accessed if [Input Filter] , F , is set to [Yes] y e s . Factory setting
[Warning]	w a r n	DC bus ripple monitoring function is enabled. In case of DC bus ripple, the drive triggers [DC Bus Ripple Warn] d C r W warning.
[Error]	F L E	The DC bus ripple monitoring function is fully enabled. The drive triggers [DC Bus Ripple Error] d C r E error if [DC Bus Ripple Warn] d C r W warning is persistent.

[Define system units]

[Define system units] 5 ⌂ ⌂ - Menu

Access

[Complete settings] → [Define system units]

About This Menu

In order to be easy to configure, commission, operate, and maintain, the drive uses the application units.

The physicals that are concerned by application units are:

- Pressure values
- Flow rate values
- Temperature values
- Currency values

NOTE: Some other default system units are automatically deduced from configurable system units or from other parameters.

System unit applies by default to all communication parameters and HMI (Graphic Display Terminal, Web server, DTM-based software).

When a system unit is changed, there is no rescaling of values. Numerical values are kept, but the meaning of these values is not the same:

- After a change, the behavior of the product will not change (the system stays numerically the same).
- If new values are written through communication or through HMI in new unit, then the behavior is impacted. In that case, all parameters should be reconfigured according to the new selected unit.
- In order to avoid issues due to a modification of system unit parameters, system units should be modified only during the installation of the product and before the commissioning of the functions.

The precision of the physical values is selected at the same time as the unit.

By default, values are signed.

Default range of values are:

16 bits values	32 bits values
-32,768...32,767	-2,147,483,648...2,147,483,648

[P sensor unit] 5 ⌂ P ⌂

Default system application unit used for pressure.

Available pressure units:

Unit	Symbol	Conversion
Kilo Pascal	kPa	100 kPa = 1 bar
Millibar	mbar	
Bar	bar	
Pound / square inch (lb/in ²)	psi psig	14.5 psi = 1 bar
Inch H2O	inH2O	1 inH2O 4°C = 0.0024908891 bar (0.036127292 psi)

Unit	Symbol	Conversion
Inch water gauge Inch water column	inWG inWC	
Feet water gauge Feet water column Feet	ftWG ftWC ft	1 inH ₂ O 4°C = 0.0298906692 bar (0.433527504 psi)
Meter water gauge Meter water column Meter	mWG mWC (mCE) m	1 mH ₂ O(4°C) = 0.0980665 bar (1.42233433 psi)
Inch of mercury	inHg	1 inHg = 0.0338638864 bar (0.491154147 psi)
Percentage	%	-
w/o unit	-	-

Setting	Code / Value	Description
[1Kpa]	<i>P A</i>	1 kpa
[1mbar]	<i>I n b a r</i>	1 mbar
[1Bar]	<i>b a r</i>	1 bar
[0.1Bar]	<i>0.1 b a r</i>	0.1 bar Factory setting
[0.01Bar]	<i>0.01 b a r</i>	0.01 bar
[1 PSI]	<i>P S I</i>	1 Psi
[0.1 PSI]	<i>0.1 P S I</i>	0.1 psi
[1 PSIG]	<i>P S I G</i>	1 Psig
[0.1 PSIG]	<i>0.1 P S I G</i>	0.1 Psig
[1inH2O]	<i>I i n H 2 O</i>	1 inH ₂ O
[1inWg]	<i>I i n W G</i>	1 inWg
[1inWC]	<i>I i n W C</i>	1 inWc
[1 FtWg]	<i>I F t W G</i>	1 FtWg
[1 FtWC]	<i>I F t W C</i>	1 FtWC
[1 Ft]	<i>I F t</i>	1 Ft
[1 MWG]	<i>I n W G</i>	1 mWg
[0.1 MWG]	<i>0.1 n W G</i>	0.1 mWg
[1 MWC]	<i>I n W C</i>	1 mWC
[0.1 MWC]	<i>0.1 n W C</i>	0.1 mWC
[1m]	<i>I n</i>	1 m
[0.1 m]	<i>0.1 n</i>	0.1 m
[1 inHG]	<i>I i n H G</i>	1 inHg
[0.1%]	<i>0.1%</i>	0.1%
[0.1]	<i>0.1 w/o</i>	0.1 w/o

[Flow rate unit] S U F r

Default system application unit used for flow rate.

Available flow units:

Unit	Symbol	Conversion
Liter / second	l/s	–
Liter / minute	l/min	–
Liter / hour	l/h	–
Cubic decimeter / minute	dm ³ /min	–
Cubic meter / second	m ³ /s	–
Cubic meter / minute	m ³ /min	–
Cubic meter / hour	m ³ /h	–
Gallon per second	gal/s	1 usgal = 3,785411784 l
Gallon per minute	gal/min; GPM	–
Gallon per hour	gal/h	–
Cubic feet / second	ft ³ /s	1 ft ³ = 28.317 l
Cubic feet / minute	ft ³ /min; CFM, SCFM	–
Cubic feet / hour	ft ³ /h	–
Percentage	%	–
w/o unit	–	–

Setting	Code / Value	Description
[1 L/s]	1 L S	L/s
[l/s]	0 1 L S	0.1 L/s
[1 L/m]	1 L m	L/m
[1 L/h]	1 L h	L/h
[1 dm ³ /mn]	1 d m 3 m	d ³ /m
[1 m ³ /s]	1 m 3 S	M ³ /s
[0.1 m ³ /s]	0 1 m 3 S	0.1 M ³ /s
[1m ³ /m]	1 m 3 m	M ³ /min
[0.1 m ³ /m]	0 1 m 3 m	0.1 M ³ /min
[1 m ³ /h]	1 m 3 h	1 M ³ /h
[0.1m ³ /h]	0 1 m 3 h	0.1 M ³ /h
		Factory setting
[1 gal/s]	1 G P S	1 Gal/s
[1 GPM]	1 G P m	1 GPM
[1 gal/h]	1 G P H	1 Gal/h
[1 ft ³ /s]	1 C F S	1 ft ³ /s
[1CFM]	1 C F m	1 CFM
[1SCFM]	1 S C F m	1 SCFM
[1 Ft ³ /h]	1 C F H	1 ft ³ /h
[1 Kg/s]	1 G S	1 kg/s
[1 Kg/m]	1 G m	1 kg/m
[1 Kg/h]	1 G H	1 kg/h

Setting	Code / Value	Description
[1 Lb/s]	<i>l l b s</i>	1 lb/s
[1 Lb/m]	<i>l l b m</i>	1 lb/m
[1 Lb/h]	<i>l l b h</i>	1 lb/h
[0.1%]	<i>0 1 P C</i>	0.1%
[0.1]	<i>0 1 w o</i>	0.1 w/o

[Temperature unit] *S U E P*

Default system application unit used for temperature.

Available temperature units:

Unit	Symbol	Conversion
Celsius Degree	°C	–
Fahrenheit Degree	°F	TF = 9/5*Tc+32
Percentage	%	–
w/o unit	–	–

Setting	Code / Value	Description
[0.1°C]	<i>0 1 C</i>	0.1 °C Factory setting
[0.1°F]	<i>0 1 F</i>	0.1 °F
[0.1%]	<i>0 1 P C</i>	0.1%
[0.1]	<i>0 1 w o</i>	0.1 w/o

[Currency unit list] *S U C U*

Default system application unit used for currency.

Setting	Code / Value	Description
[EURO]	<i>E u r o</i>	Euro Factory setting
[\$]	<i>d o l l a r</i>	Dollar
[£]	<i>P o u n d</i>	Pound
[Krone]	<i>K r</i>	Krone
[Renminbi]	<i>r m b</i>	Renminbi
[Other]	<i>o t h e r</i>	Other

[Liquid Density] *r H o*

Density of the fluid to be pumped.

This parameter can be accessed if [Access Level] *L R C* is not set to [Expert] *E P r*.

Setting	Description
100...10,000 kg/m ³	Setting range Factory setting: 1000 kg/m ³

[Sensors assignment]

[Sensors assignment] 5 5 5 - Menu

Access

[Complete settings] → [Sensors assignment]

About This Menu

This menu is used to set the sensors.

In case of mixing absolute and relative sensors, verify the consistency between all sensor data and adjust if necessary by using the process value scaling and the analog inputs operation functions.

[InletPres Assign] P 5 1 R

Inlet pressure sensor assignment.

Setting	Code / Value	Description
[Not Configured]	n o	Not assigned Factory setting
[AI1]...[AI3]	R , 1...R , 3	Analog input AI1...AI3
[AI4]...[AI5]	R , 4...R , 5	Analog input AI4...AI5 if VW3A3203 I/O extension module has been inserted
[AI Virtual 1]... [AI Virtual 3]	R , V 1... R , V 3	Virtual analogic input 1...3
NOTE: For sensor configuration, refer to section [Sensors assignment] , page 200.		

[OutletPres Assign] P 5 2 R

Outlet pressure sensor assignment.

Setting	Code / Value	Description
[Not Configured]	n o	Not assigned Factory setting
[AI1]...[AI3]	R , 1...R , 3	Analog input AI1...AI3
[AI4]...[AI5]	R , 4...R , 5	Analog input AI4...AI5 if VW3A3203 I/O extension module has been inserted
[AI Virtual 1]... [AI Virtual 3]	R , V 1... R , V 3	Virtual analogic input 1...3
NOTE: For sensor configuration, refer to section [Sensors assignment] , page 200.		

[Inst. Flow Assign.] F 5 1 R

Installation flow sensor assignment.

Setting	Code / Value	Description
[Not Configured]	<i>n o</i>	Not assigned Factory setting
[AI1]...[AI3]	<i>R , 1...R , 3</i>	Analog input AI1...AI3
[AI4]...[AI5]	<i>R , 4...R , 5</i>	Analog input AI4...AI5 if VW3A3203 I/O extension module has been inserted
[AI Virtual 1]... [AI Virtual 3]	<i>R , V 1... R , V 3</i>	Virtual analogic input 1...3
[Di5 PulseInput Assign- ment]...[Di6 PulseInput Assignment]	<i>P , 5...P , 6</i>	Digital input DI5...DI6 used as pulse input
[Est. Pump Flow]	<i>S L P F</i>	Sensor less estimated flow
[Est. System Flow]	<i>S L S F</i>	Estimated system flow This selection is only possible if [Pump System Archit] <i>Π P S R</i> is set to [Multi Drives] <i>n V S d</i> or [Multi Masters] <i>n V S d r</i> NOTE: To use this selection, all the pump characteristics of the system must be configured.
NOTE: For sensor configuration, refer to section [Sensors assignment] , page 200.		

[Pump Flow Assign.] *F S Z R*

Pump flow sensor assignment.

Setting	Code / Value	Description
[Not Configured]	<i>n o</i>	Not assigned Factory setting
[AI1]...[AI3]	<i>R , 1...R , 3</i>	Analog input AI1...AI3
[AI4]...[AI5]	<i>R , 4...R , 5</i>	Analog input AI4...AI5 if VW3A3203 I/O extension module has been inserted
[AI Virtual 1]... [AI Virtual 3]	<i>R , V 1... R , V 3</i>	Virtual analogic input 1...3
[Di5 PulseInput Assign- ment]...[Di6 PulseInput Assignment]	<i>P , 5...P , 6</i>	Digital input DI5...DI6 used as pulse input
[Est. Pump Flow]	<i>S L P F</i>	Sensor less estimated flow
NOTE: For sensor configuration, refer to section [Sensors assignment] , page 200.		

[Level Sensor Assign] *L C S R* ★

Level sensor assignment.

This parameter can be accessed if **[Application Selection]** *R P P L* is set to **[Level]** *L E V E L* .

Setting	Code / Value	Description
[Not Configured]	n 0	Not assigned Factory setting
[AI1]...[AI3]	R , 1...R , 3	Analog input AI1...AI3
[AI4]...[AI5]	R , 4...R , 5	Analog input AI4...AI5 if VW3A3203 I/O extension module has been inserted
[AI Virtual 1]... [AI Virtual 3]	R , V 1... R , V 3	Virtual analogic input 1...3
NOTE: For sensor configuration, refer to section [Sensors assignment] , page 200.		

[AI1 sensor config.] Menu

About This Menu

Access of **[AI1 Sensor Config.]** menu depends of the sensor assigned to this input.

The following table shows the **[AI1 Sensor Config.]** menus displayed in relation with the sensor and the applicative function used.

If...	And...	Then following menu will be displayed:
[InletPres Assign] P S I R is set to [AI1] R , I	-	[AI1 Sensor Config.] , C R I -
	[Priming Pump Assign] P P a R is not set to [No] n o , page 375	[AI1 Sensor Config.] P P R I -
	[InletPres Monitoring] , P P n is not set to [No] n o , page 410	[AI1 Sensor Config.] , P R I -
[OutletPres Assign] P S z R is set to [AI1] R , I	-	[AI1 Sensor Config.] a C R I -
	[Sleep Detect Mode] S L P n is set to [Pressure] H P or [Multiple] a r . , page 327	[AI1 Sensor Config.] S a R I -
	[Wake Up Mode] W u P n is set to [Pressure] L P . , page 327	[AI1 Sensor Config.] W a R I -
	[Activation Mode] P F n is set to [Outlet Pressure] P S z . , page 363	[AI1 Sensor Config.] P F R I -
	[OutPres Monitoring] a P P n is set to [Sensor] S n S r or [Both] b o t h . , page 415	[AI1 Sensor Config] a a R I -
[Inst. Flow Assign.] F S I R is set to [AI1] R , I	-	[AI1 Sensor Config.] , I F I -
	[LevelCtrl Strategy] L C S E is set to [Energy Optimized] R d V . , page 281	[AI1 Sensor Config.] L , I F I -
	[Sleep Detect Mode] S L P n is set to [Flow] L F or [Multiple] a r . , page 327	[AI1 Sensor Config.] S , I F I -
	[Mode Selection] F L C n is not set to [Inactive] n o . , page 368	[AI1 Sensor Config.] F , I F I -
	[Flow limitation Mode] F L n is not set to [No] n o . , page 379	[AI1 Sensor Config.] L F I -
	[HighFlow Activation] H F P n is not set to [No] n o .	[AI1 Sensor Config.] H , I F I -

If...	And...	Then following menu will be displayed:
	, page 420	
	<ul style="list-style-type: none"> [Booster Control] <i>b C Π</i> is set to [Yes] <i>Y E S</i> [Booster S/D Condition] <i>b S d C</i> is set to [Speed +Flow] <i>S P F L</i>. , page 244	[AI1 Sensor Config.] <i>b , F I -</i>
[Pump Flow Assign.] <i>F S 2 R</i> is set to [AI1] <i>R , I</i>	-	[AI1 Sensor Config.] <i>P F I -</i>
	[PumpLF Monitoring] <i>P L F Π</i> is set to [Flow] <i>q</i> or [Flow vs Speed] <i>q n</i> . , page 403	[AI1 Sensor Config.] <i>n P F I -</i>
[Level Sensor Assign] <i>L C S R</i> is set to [AI1] <i>R , I</i>	, page 281	[AI1 Sensor Config.] <i>L C R I -</i>
NOTE: The list of parameters is the same for each [AI1 Sensor Config.] menu.		

[AI1 Type] *R , I E*

Configuration of analog input AI1.

Setting	Code / Value	Description
[Voltage]	<i>I 0 v</i>	0-10 Vdc Factory setting
[Current]	<i>0 R</i>	0-20 mA

[AI1 min value] *v , L I ★*

AI1 voltage scaling parameter of 0%.

This parameter can be accessed if [AI1 Type] *R , I E* is set to [Voltage] *I 0 v*.

Setting	Description
0.0...10.0 Vdc	Setting range Factory setting: 0.0 Vdc

[AI1 max value] *v , H I ★*

AI1 voltage scaling parameter of 100%.

This parameter can be accessed if [AI1 Type] *R , I E* is set to [Voltage] *I 0 v*.

Setting	Description
0.0...10.0 Vdc	Setting range Factory setting: 10.0 Vdc

[AI1 min. value] C r L I ★

AI1 current scaling parameter of 0%.

This parameter can be accessed if [AI1 Type] R , I E is set to [Current] D R .

Setting	Description
0.0...20.0 mA	Setting range Factory setting: 0.0 mA

[AI1 max. value] C r H I ★

AI1 current scaling parameter of 100%.

This parameter can be accessed if [AI1 Type] R , I E is set to [Current] D R .

Setting	Description
0.0...20.0 mA	Setting range Factory setting: 20.0 mA

[AI1 Lowest Process] R , I J

AI1 lowest process.

Setting	Description
-32,767...32,767	Setting range. Value in application customer unit. Factory setting: 0

[AI1 Highest Process] R , I K

AI1 highest process.

Setting	Description
-32,767...32,767	Setting range. Value in application customer unit Factory setting: 0

[AI1 range] R , I L

AI1 scaling selection.

This parameter can be accessed if [AI1 Type] R , I E is set to [Current] D R .

This parameter is forced to [0-100%] P o 5 if:

- [AI1 Type] R , I E is not set to [Current] D R , or
- [AI1 min. value] C r L I is lower than 3.0 mA.

Setting	Code / Value	Description
[0-100%]	P o 5	Unidirectional: AI1 current scaling is 0% up to 100%. Factory setting
[-/+100%]	P o 5 n E G	Bidirectional: AI1 current scaling is -100% up to 100%. [AI1 min. value] C r L I corresponds to -100%. [AI1 max. value] C r H I corresponds to 100%.

[AI2 sensor config.] Menu

About This Menu

Access of **[AI2 Sensor Config.]** menu depends of the sensor assigned to this input.

The following table shows the **[AI2 Sensor Config.]** menus displayed in relation with the sensor and the applicative function used.

If...	And...	Then following menu will be displayed:
[InletPres Assign] P S I R is set to [AI2] R , 2	-	[AI2 Sensor Config.] , C R 2 -
	[Priming Pump Assign] P P o R is not set to [No] n o , page 375.	[AI2 Sensor Config.] P P R 2 -
	[InletPres Monitoring] , P P n is not set to [No] n o , page 410.	[AI2 Sensor Config.] , P R 2 -
[OutletPres Assign] P S 2 R is set to [AI2] R , 2	-	[AI2 Sensor Config.] o C R 2 -
	[Sleep Detect Mode] S L P n is set to [Pressure] H P or [Multiple] o r , page 327.	[AI2 Sensor Config.] S o R 2 -
	[Wake Up Mode] W u P n is set to [Pressure] L P , page 327.	[AI2 Sensor Config.] W o R 2 -
	[Activation Mode] P F n is set to [Outlet Pressure] P S 2 , page 363.	[AI2 Sensor Config.] P F R 2 -
	[OutPres Monitoring] o P P n is set to [Sensor] S n S r or [Both] b o t h , page 415.	[AI2 Sensor Config.] o o R 2 -
[Inst. Flow Assign.] F S I R is set to [AI2] R , 2	-	[AI2 Sensor Config.] , F 2 -
	[LevelCtrl Strategy] L C S E is set to [Energy Optimized] R d V , page 281.	[AI2 Sensor Config.] L , F 2 -
	[Sleep Detect Mode] S L P n is set to [Flow] L F or [Multiple] o r , page 327.	[AI2 Sensor Config.] S , F 2 -
	[Mode Selection] F L C n is not set to [Inactive] n o , page 368.	[AI2 Sensor Config.] F , F 2 -
	[Flow limitation Mode] F L n is not set to [No] n o , page 379.	[AI2 Sensor Config.] L F 2 -
	[HighFlow Activation] H F P n is not set to [No] n o , page 420.	[AI2 Sensor Config.] H , F 2 -
	<ul style="list-style-type: none"> [Booster Control] b C n is set to [Yes] Y E S [Booster S/D Condition] b S d C is set to [Speed +Flow] S P F L , page 244. 	[AI2 Sensor Config.] b , F 2 -
[Pump Flow Assign.] F S 2 R is set to [AI2] R , 2	-	[AI2 Sensor Config.] P F 2 -

If...	And...	Then following menu will be displayed:
	[PumpLF Monitoring] <i>P L F Π</i> is set to [Flow] <i>9 n</i> or [Flow vs Speed] <i>9 n</i> , page 403.	[AI2 Sensor Config.] <i>n P F 2 -</i>
[Level Sensor Assign] <i>L C S A</i> is set to [AI2] <i>A , 2</i>	, page 281.	[AI2 Sensor Config.] <i>L C A 2 -</i>
NOTE: The list of parameters is the same for each [AI2 Sensor Config.] menu.		

[AI2 Type] *A , 2 E*

Configuration of analog input AI2.

Setting	Code / Value	Description
[Voltage]	<i>1 0 v</i>	0-10 Vdc Factory setting
[Current]	<i>0 A</i>	0-20 mA

[AI2 min value] *v , L 2 ★*

AI2 voltage scaling parameter of 0%.

This parameter can be accessed if **[AI2 Type]** *A , 2 E* is set to **[Voltage]** *1 0 v*.

Identical to **[AI1 min value]** *v , L 1*, page 204.

[AI2 max value] *v , H 2 ★*

AI2 voltage scaling parameter of 100%.

This parameter can be accessed if **[AI2 Type]** *A , 2 E* is set to **[Voltage]** *1 0 v*.

Identical to **[AI1 max value]** *v , H 1*, page 204.

[AI2 min. value] *C r L 2 ★*

AI2 current scaling parameter of 0%.

This parameter can be accessed if **[AI2 Type]** *A , 2 E* is set to **[Current]** *0 A*.

Identical to **[AI1 min. value]** *C r L 1*, page 205.

[AI2 max. value] *C r H 2 ★*

AI2 current scaling parameter of 100%.

This parameter can be accessed if **[AI2 Type]** *A , 2 E* is set to **[Current]** *0 A*.

Identical to **[AI1 max. value]** *C r H 1*, page 205.

[AI2 Lowest Process] *A , 2 J*

AI2 lowest process.

Identical to **[AI1 Lowest Process] P , 1 J** , page 205.

[AI2 Highest Process] P , 2 K

AI2 highest process.

Identical to **[AI1 Highest Process] P , 1 K** , page 205.

[AI2 range] P , 2 L

AI2 scaling selection.

This parameter can be accessed if **[AI2 Type] P , 2 E** is set to **[Current] 0 P**.

Identical to **[AI1 range] P , 1 L** , page 205.

[AI3 sensor config.] Menu

About This Menu

Access of **[AI3 Sensor Config.]** menu depends of the sensor assigned to this input.

The following table shows the **[AI3 Sensor Config.]** menus displayed in relation with the sensor and the applicative function used.

If...	And...	Then following menu will be displayed:
[InletPres Assign] P S I R is set to [AI3] R , E	-	[AI3 Sensor Config.] I C R E -
	[Priming Pump Assign] P P A is not set to [No] n o , page 375	[AI3 Sensor Config.] P P R E -
	[InletPres Monitoring] I P P M is not set to [No] n o , page 410	[AI3 Sensor Config.] I P R E -
[OutletPres Assign] P S O R is set to [AI3] R , E	-	[AI3 Sensor Config.] O C R E -
	[Sleep Detect Mode] S L P M is set to [Pressure] H P or [Multiple] o r . , page 327	[AI3 Sensor Config.] S O R E -
	[Wake Up Mode] W U P M is set to [Pressure] L P . , page 327	[AI3 Sensor Config.] W O R E -
	[Activation Mode] P F M is set to [Outlet Pressure] P S O . , page 363	[AI3 Sensor Config.] P F R E -
	[OutPres Monitoring] O P P M is set to [Sensor] S n S r or [Both] b o t h . , page 415	[AI3 Sensor Config] O O R E -
[Inst. Flow Assign.] F S I R is set to [AI3] R , E	-	[AI3 Sensor Config.] , I F E -
	[LevelCtrl Strategy] L C S E is set to [Energy Optimized] R d V . , page 281	[AI3 Sensor Config.] L , I F E -
	[Sleep Detect Mode] S L P M is set to [Flow] L F or [Multiple] o r . , page 327	[AI3 Sensor Config.] S , I F E -
	[Mode Selection] F L C M is not set to [Inactive] n o . , page 368	[AI3 Sensor Config.] F , I F E -
	[Flow limitation Mode] F L M is not set to [No] n o . , page 379	[AI3 Sensor Config.] L F E -
	[HighFlow Activation] H F P M is not set to [No] n o .	[AI3 Sensor Config.] H , I F E -

If...	And...	Then following menu will be displayed:
	, page 420	
	<ul style="list-style-type: none"> [Booster Control] <i>b c n</i> is set to [Yes] <i>y e s</i> [Booster S/D Condition] <i>b s d c</i> is set to [Speed +Flow] <i>s p f l</i>. , page 244	[AI3 Sensor Config.] <i>b , f 3 -</i>
[Pump Flow Assign.] <i>f s 2 a</i> is set to [AI3] <i>a , 3</i>	-	[AI3 Sensor Config.] <i>p f 3 -</i>
	[PumpLF Monitoring] <i>p l f n</i> is set to [Flow] <i>q</i> or [Flow vs Speed] <i>q n</i> . , page 403	[AI3 Sensor Config.] <i>n p f 3 -</i>
[Level Sensor Assign] <i>l c s a</i> is set to [AI3] <i>a , 3</i>	, page 281	[AI3 Sensor Config.] <i>l c a 3 -</i>
NOTE: The list of parameters is the same for each [AI3 Sensor Config.] menu.		

[AI3 Type] *a , 3 t*

Configuration of analog input AI3.

Setting	Code / Value	Description
[Voltage]	<i>l 0 u</i>	0-10 Vdc
[Current]	<i>0 a</i>	0-20 mA
		Factory setting

[AI3 min value] *u , l 3 ★*

AI3 voltage scaling parameter of 0%.

This parameter can be accessed if [AI3 Type] *a , 3 t* is set to [Voltage] *l 0 u*.

Identical to [AI1 min value] *u , l 1*, page 204.

[AI3 max value] *u , h 3 ★*

AI3 voltage scaling parameter of 100%.

This parameter can be accessed if [AI3 Type] *a , 3 t* is set to [Voltage] *l 0 u*.

Identical to [AI1 max value] *u , h 1*, page 204.

[AI3 min. value] *c r l 3 ★*

AI3 current scaling parameter of 0%.

This parameter can be accessed if [AI3 Type] *a , 3 t* is set to [Current] *0 a*.

Identical to [AI1 min. value] *c r l 1*, page 205.

[AI3 max. value] C r H E ★

AI3 current scaling parameter of 100%.

This parameter can be accessed if **[AI3 Type] R , E E** is set to **[Current] 0 R**.

Identical to **[AI1 max. value] C r H I**, page 205.

[AI3 Lowest Process] R , E J

AI3 lowest process.

Identical to **[AI1 Lowest Process] R , I J**, page 205.

[AI3 Highest Process] R , E K

AI3 highest process.

Identical to **[AI1 Highest Process] R , I K**, page 205.

[AI3 range] R , E L

AI3 scaling selection.

This parameter can be accessed if **[AI3 Type] R , E E** is set to **[Current] 0 R**.

Identical to **[AI1 range] R , I L**, page 205.

[AI4 sensor config.] Menu

About This Menu

Access of **[AI4 Sensor Config.]** menu depends of the sensor assigned to this input.

The following table shows the **[AI4 Sensor Config.]** menus displayed in relation with the sensor and the applicative function used.

If...	And...	Then following menu will be displayed:
[InletPres Assign] P 5 I R is set to [AI4] R , 4	-	[AI4 Sensor Config.] , C R 4 -
	[Priming Pump Assign] P P o R is not set to [No] n o , page 375.	[AI4 Sensor Config.] P P R 4 -
	[InletPres Monitoring] , P P n is not set to [No] n o , page 410.	[AI4 Sensor Config.] , P R 4 -
[OutletPres Assign] P 5 o R is set to [AI4] R , 4	-	[AI4 Sensor Config.] o C R 4 -
	[Sleep Detect Mode] S L P n is set to [Pressure] H P or [Multiple] o r , page 327.	[AI4 Sensor Config.] S o R 4 -
	[Wake Up Mode] W u P n is set to [Pressure] L P , page 327.	[AI4 Sensor Config.] W o R 4 -
	[Activation Mode] P F n is set to [Outlet Pressure] P 5 o , page 363.	[AI4 Sensor Config.] P F R 4 -
	[OutPres Monitoring] o P P n is set to [Sensor] S n S r or [Both] b o t h , page 415.	[AI4 Sensor Config] o o R 4 -
[Inst. Flow Assign.] F 5 I R is set to [AI4] R , 4	-	[AI4 Sensor Config.] , F 4 -
	[LevelCtrl Strategy] L C S E is set to [Energy Optimized] R d V , page 281.	[AI4 Sensor Config.] LIF4-
	[Sleep Detect Mode] S L P n is set to [Flow] L F or [Multiple] o r , page 327.	[AI4 Sensor Config.] S , F 4 -
	[Mode Selection] F L C n is not set to [Inactive] n o , page 368.	[AI4 Sensor Config.] F , F 4 -
	[Flow limitation Mode] F L n is not set to [No] n o , page 379.	[AI4 Sensor Config.] L F 4 -
	[HighFlow Activation] H F P n is not set to [No] n o , page 420.	[AI4 Sensor Config.] H , F 4 -
	<ul style="list-style-type: none"> [Booster Control] b C n is set to [Yes] Y E S [Booster S/D Condition] b S d C is set to [Speed +Flow] S P F L , page 244. 	[AI4 Sensor Config.] b , F 4 -
[Pump Flow Assign.] F 5 o R is set to [AI4] R , 4	-	[AI4 Sensor Config.] P F 4 -

If...	And...	Then following menu will be displayed:
	[PumpLF Monitoring] P L F Π is set to [Flow] 9 or [Flow vs Speed] 9 n , page 403.	[AI4 Sensor Config.] n P F 4 -
[Level Sensor Assign] L C S A is set to [AI4] A , 4	, page 281	[AI4 Sensor Config.] L C A 4 -
NOTE: The list of parameters is the same for each [AI4 Sensor Config.] menu.		

[AI4 Type] A , 4 E

Configuration of analog input AI4.

Setting	Code / Value	Description
[Voltage]	1 0 u	0-10 Vdc
[Current]	0 A	0-20 mA Factory setting

[AI4 min value] u , L 4 ★

AI4 voltage scaling parameter of 0%.

This parameter can be accessed if [AI4 Type] A , 4 E is set to [Voltage] 1 0 u.

Identical to [AI1 min value] u , L 1 , page 204.

[AI4 max value] u , H 4 ★

AI4 voltage scaling parameter of 100%.

This parameter can be accessed if [AI4 Type] A , 4 E is set to [Voltage] 1 0 u.

Identical to [AI1 max value] u , H 1 , page 204.

[AI4 min. value] C r L 4 ★

AI4 current scaling parameter of 0%.

This parameter can be accessed if [AI4 Type] A , 4 E is set to [Current] 0 A.

Identical to [AI1 min. value] C r L 1 , page 205.

[AI4 max. value] C r H 4 ★

AI4 current scaling parameter of 100%.

This parameter can be accessed if [AI4 Type] A , 4 E is set to [Current] 0 A.

Identical to [AI1 max. value] C r H 1 , page 205.

[AI4 Lowest Process] A , 4 J

AI4 lowest process.

Identical to **[AI1 Lowest Process] R , 1 J** , page 205.

[AI4 Highest Process] R , 4 K

AI4 highest process.

Identical to **[AI1 Highest Process] R , 1 K** , page 205.

[AI4 range] R , 4 L

AI4 scaling selection.

This parameter can be accessed if **[AI4 Type] R , 4 E** is set to **[Current] 0 R**.

Identical to **[AI1 range] R , 1 L** , page 205.

[AI5 sensor config.] Menu

About This Menu

Access of **[AI5 Sensor Config.]** menu depends of the sensor assigned to this input.

The following table shows the **[AI5 Sensor Config.]** menus displayed in relation with the sensor and the applicative function used.

If...	And...	Then following menu will be displayed:
[InletPres Assign] P S I R is set to [AI5] R , S	-	[AI5 Sensor Config.] , C R S -
	[Priming Pump Assign] P P a R is not set to [No] n o , page 375.	[AI5 Sensor Config.] P P R S -
	[InletPres Monitoring] , P P n is not set to [No] n o , page 410.	[AI5 Sensor Config.] , P R S -
[OutletPres Assign] P S 2 R is set to [AI5] R , S	-	[AI5 Sensor Config.] a C R S -
	[Sleep Detect Mode] S L P n is set to [Pressure] H P or [Multiple] a r , page 327.	[AI5 Sensor Config.] S a R S -
	[Wake Up Mode] W u P n is set to [Pressure] L P , page 327.	[AI5 Sensor Config.] W a R S -
	[Activation Mode] P F n is set to [Outlet Pressure] P S 2 , page 363.	[AI5 Sensor Config.] P F R S -
	[OutPres Monitoring] a P P n is set to [Sensor] S n S r or [Both] b o t h , page 415.	[AI5 Sensor Config.] a a R S -
[Inst. Flow Assign.] F S I R is set to [AI5] R , S	-	[AI5 Sensor Config.] , F S -
	[LevelCtrl Strategy] L C S E is set to [Energy Optimized] R d V , page 281.	[AI5 Sensor Config.] L , F S -
	[Sleep Detect Mode] S L P n is set to [Flow] L F or [Multiple] a r , page 327.	[AI5 Sensor Config.] S , F S -
	[Mode Selection] F L C n is not set to [Inactive] n o , page 368.	[AI5 Sensor Config.] F , F S -
	[Flow limitation Mode] F L n is not set to [No] n o , page 379.	[AI5 Sensor Config.] L F S -
	[HighFlow Activation] H F P n is not set to [No] n o , page 420.	[AI5 Sensor Config.] H , F S -
	<ul style="list-style-type: none"> [Booster Control] b C n is set to [Yes] Y E S [Booster S/D Condition] b S d C is set to [Speed +Flow] S P F L , page 244. 	[AI5 Sensor Config.] b , F S -
[Pump Flow Assign.] F S 2 R is set to [AI5] R , S	-	[AI5 Sensor Config.] P F S -

If...	And...	Then following menu will be displayed:
	[PumpLF Monitoring] PLFN is set to [Flow] 9 or [Flow vs Speed] 9 [Pump monitoring] - [Pump low flow Monit], page 403.	[AI5 Sensor Config.] n P F 5 -
[Level Sensor Assign] L C 5 A is set to [AI5] A , 5	, page 281.	[AI5 Sensor Config.] L C A 5 -
NOTE: The list of parameters is the same for each [AI5 Sensor Config.] menu.		

[AI5 Type] A , 5 E

Configuration of analog input AI5.

Setting	Code / Value	Description
[Voltage]	1 0 u	0-10 Vdc
[Current]	0 A	0-20 mA Factory setting

[AI5 min value] u , L 5 ★

AI5 voltage scaling parameter of 0%.

This parameter can be accessed if **[AI5 Type] A , 5 E** is set to **[Voltage] 1 0 u**.

Identical to **[AI1 min value] u , L 1**, page 204.

[AI5 max value] u , H 5 ★

AI5 voltage scaling parameter of 100%.

This parameter can be accessed if **[AI5 Type] A , 5 E** is set to **[Voltage] 1 0 u**.

Identical to **[AI1 max value] u , H 1**, page 204.

[AI5 min. value] C r L 5 ★

AI5 current scaling parameter of 0%.

This parameter can be accessed if **[AI5 Type] A , 5 E** is set to **[Current] 0 A**.

Identical to **[AI1 min. value] C r L 1**, page 205.

[AI5 max. value] C r H 5 ★

AI5 current scaling parameter of 100%.

This parameter can be accessed if **[AI5 Type] A , 5 E** is set to **[Current] 0 A**.

Identical to **[AI1 max. value] C r H 1**, page 205.

[AI5 Lowest Process] $\text{P} 5 \text{J}$

AI5 lowest process.

Identical to [AI1 Lowest Process] $\text{P} 1 \text{J}$, page 205.

[AI5 Highest Process] $\text{P} 5 \text{K}$

AI5 highest process.

Identical to [AI1 Highest Process] $\text{P} 1 \text{K}$, page 205.

[AI5 range] $\text{P} 5 \text{L}$

AI5 scaling selection.

This parameter can be accessed if [AI5 Type] $\text{P} 5 \text{E}$ is set to [Current] $\text{P} \text{A}$.

Identical to [AI1 range] $\text{P} 1 \text{L}$, page 205.

[PI5 Sensor Config] Menu

About This Menu

Access of **[DI5 Pulse Sensor Config.]** menu depends of the sensor assigned to this input.

The following table shows the **[DI5 Pulse Sensor Config.]** menus displayed in relation with the sensor and the applicative function used.

If...	And...	Then following menu will be displayed:
[Inst. Flow Assign.] F 5 I R is set to [Di5 PulseInput Assignment] P , 5	-	[DI5 Pulse Sensor Config.] F B -
	[LevelCtrl Strategy] L C 5 L is set to [Energy Optimized] R d V , page 281.	[DI5 Pulse Sensor Config.] L , P 5 -
	[Sleep Detect Mode] S L P Π is set to [Flow] L F or [Multiple] o r , page 327.	[DI5 Pulse Sensor Config.] S , F B -
	[Mode Selection] F L C Π is not set to [Inactive] n o , page 368.	[DI5 Pulse Sensor Config.] F , F B -
	[Flow limitation Mode] F L Π is not set to [No] n o , page 379.	[DI5 Pulse Sensor Config.] L F B -
	[HighFlow Activation] H F P Π is not set to [No] n o , page 420.	[DI5 Pulse Sensor Config.] H , F B -
	<ul style="list-style-type: none"> [Booster Control] b C Π is set to [Yes] Y E S [Booster S/D Condition] b S d C is set to [Speed +Flow] S P F L, page 244 	[DI5 Pulse Sensor Config.] b , P 5 -
[Pump Flow Assign.] F 5 P R is set to [Di5 PulseInput Assignment] P , 5	-	[DI5 Pulse Sensor Config.] P F B -
	[PumpLF Monitoring] P L F Π is set to [Flow] q or [Flow vs Speed] q n , page 403.	[DI5 Pulse Sensor Config.] n P F B -
NOTE: The list of parameters is the same for each [DI5 Pulse Sensor Config.] menu.		

[DI5 PulseInput Low Freq] P , L 5

Pulse input DI5 low frequency.

Setting	Description
0.00...30,000.00 Hz	Setting range Factory setting: 0.00 Hz

[DI5 PulseInput High Freq] P , H 5

Pulse input DI5 high frequency.

Setting	Description
0.00...30.00 kHz	Setting range Factory setting: 30.00 kHz

[DI5 Min Process] P , 5 J

Minimum process value for selected input.

Setting	Description
-32,767...32,767	Setting range Factory setting: 0

[DI5 Max Process] P , 5 K

Maximum process value for selected input.

Setting	Description
-32,767...32,767	Setting range Factory setting: 0

[PI6 Sensor Config] Menu

About This Menu

Access of **[DI6 Pulse Sensor Config.]** menu depends of the sensor assigned to this input.

The following table shows the **[DI6 Pulse Sensor Config.]** menus displayed in relation with the sensor and the applicative function used.

If...	And...	Then following menu will be displayed:
[Inst. Flow Assign.] F 5 I R is set to [Di6 PulseInput Assignment] P , E	-	[DI6 Pulse Sensor Config.] F 9 -
	[LevelCtrl Strategy] L C 5 E is set to [Energy Optimized] R d V , page 281.	[DI6 Pulse Sensor Config.] L , P 6 -
	[Sleep Detect Mode] S L P N is set to [Flow] L F or [Multiple] o r , page 327.	[DI6 Pulse Sensor Config.] S , F 9 -
	[Mode Selection] F L C N is not set to [Inactive] n o , page 368.	[DI6 Pulse Sensor Config.] F , F 9 -
	[Flow limitation Mode] F L N is not set to [No] n o , page 379.	[DI6 Pulse Sensor Config.] L F 9 -
	[HighFlow Activation] H F P N is not set to [No] n o , page 420.	[DI6 Pulse Sensor Config.] H , F 9 -
	<ul style="list-style-type: none"> • [Booster Control] b C N is set to [Yes] Y E S • [Booster S/D Condition] b S d C is set to [Speed +Flow] S P F L, page 244. 	[DI6 Pulse Sensor Config.] b , P 6 -
[Pump Flow Assign.] F 5 2 R is set to [Di6 PulseInput Assignment] P , E	-	[DI6 Pulse Sensor Config.] P F 9 -
	[PumpLF Monitoring] P L F N is set to [Flow] q or [Flow vs Speed] q n , page 403.	[DI6 Pulse Sensor Config.] n P F 9 -
NOTE: The list of parameters is the same for each [DI6 Pulse Sensor Config.] menu.		

[DI6 PulseInput Low Freq] P , L E

Pulse input DI6 low frequency.

Setting	Description
0.00...30,000.00 Hz	Setting range Factory setting: 0.00 Hz

[DI6 PulseInput High Freq] P , H E

Pulse input DI6 high frequency.

Setting	Description
0.00...30.00 kHz	Setting range Factory setting: 30.00 kHz

[DI6 Min Process] P , 5 J

Minimum process value for selected input.

Setting	Description
-32,767...32,767	Setting range Factory setting: 0

[DI6 Max Process] P , 5 K

Maximum process value for selected input.

Setting	Description
-32,767...32,767	Setting range Factory setting: 0

[AIV1 configuration] Menu

About This Menu

Access of **[AIV1 Sensor Config.]** menu depends of the sensor assigned to this input.

The following table shows the **[AIV1 Sensor Config.]** menus displayed in relation with the sensor and the applicative function used.

If...	And...	Then following menu will be displayed:
[InletPres Assign] P 5 1 R is set to [AI Virtual 1] R , V 1	-	[AIV1 Sensor Config.] C V 1 -
	[Priming Pump Assign] P P o R is not set to [No] n o , page 375.	[AIV1 Sensor Config.] P P V 1 -
	[InletPres Monitoring] P P n is not set to [No] n o , page 410.	[AIV1 Sensor Config.] P V 1 -
[OutletPres Assign] P 5 2 R is set to [AI Virtual 1] R , V 1	-	[AIV1 Sensor Config.] o C V 1 -
	[Sleep Detect Mode] S L P n is set to [Pressure] H P or [Multiple] o r , page 327.	[AIV1 Sensor Config.] S o V 1 -
	[Wake Up Mode] W u P n is set to [Pressure] L P , page 327.	[AIV1 Sensor Config.] W o V 1 -
	[Activation Mode] P F n is set to [Outlet Pressure] P 5 2 [Pump functions] - [Pipe fill] , page 363.	[AIV1 Sensor Config.] P F V 1 -
	[OutPres Monitoring] o P P n is set to [Sensor] S n S r or [Both] b o t h , page 415.	[AIV1 Sensor Config] o o V 1 -
[Inst. Flow Assign.] F 5 1 R is set to [AI Virtual 1] R , V 1	-	[AIV1 Sensor Config.] F V 1 -
	[LevelCtrl Strategy] L C 5 E is set to [Energy Optimized] R d V , page 281.	[AIV1 Sensor Config.] L , V 1 -
	[Sleep Detect Mode] S L P n is set to [Flow] L F or [Multiple] o r , page 327.	[AIV1 Sensor Config.] S , V 1 -
	[Mode Selection] F L C n is not set to [Inactive] n o , page 368.	[AIV1 Sensor Config.] F , V 1 -
	[Flow limitation Mode] F L n is not set to [No] n o , page 379.	[AIV1 Sensor Config.] L F V 1 -
	[HighFlow Activation] H F P n is not set to [No] n o , page 420.	[AIV1 Sensor Config.] H , V 1 -
	<ul style="list-style-type: none"> [Booster Control] b C n is set to [Yes] Y E S [Booster S/D Condition] b S d C is set to [Speed +Flow] S P F L, page 244. 	[AIV1 Sensor Config.] b , V 1 -

If...	And...	Then following menu will be displayed:
[Pump Flow Assign.] F S Z R is set to [AI Virtual 1] R , V I	-	[AIV1 Sensor Config.] P F V I -
	[PumpLF Monitoring] P L F Π is set to [Flow] 9 or [Flow vs Speed] 9 n , page 403.	[AIV1 Sensor Config.] n P V I -
[Level Sensor Assign] L C S R is set to [AI Virtual 1] R , V I	, page 281	[AIV1 Sensor Config.] L C V I -
NOTE: The list of parameters is the same for each [AIV1 Sensor Config.] menu.		

[AIV1 Channel Assignment] R , C I

Channel assignment for virtual analog input AIV1.

Setting	Code / Value	Description
[Not Configured]	n o	Not assigned Factory setting
[Ref. Freq-Modbus]	Π d b	Reference frequency via Modbus
[Ref. Freq-CANopen]	C R n	Reference frequency via CANopen if a CANopen module has been inserted
[Ref. Freq-Com. Module]	n E L	Reference frequency via fieldbus module if a fieldbus module has been inserted
[Embedded Ethernet]	E L H	Embedded Ethernet

[AIV1 Lowest Process] R U I J

AI virtual 1: minimum process value.

Setting	Description
-32,767...32,767	Setting range. Value in application customer unit Factory setting: 0

[AIV1 Highest Process] R U I K

AI virtual 1: maximum process value.

Setting	Description
-32,767...32,767	Setting range. Value in application customer unit Factory setting: 0

[AIV2 configuration] Menu

About This Menu

Access of **[AIV2 Sensor Config.]** menu depends of the sensor assigned to this input.

The following table shows the **[AIV2 Sensor Config.]** menus displayed in relation with the sensor and the applicative function used.

If...	And...	Then following menu will be displayed:
[InletPres Assign] <i>P S I R</i> is set to [AI Virtual 2] <i>R , V 2</i>	-	[AIV2 Sensor Config.] <i>, C V 2 -</i>
	[Priming Pump Assign] <i>P P A</i> is not set to [No] <i>n o</i> , page 375	[AIV2 Sensor Config.] <i>P P V 2 -</i>
	[InletPres Monitoring] <i>, P P I</i> is not set to [No] <i>n o</i> , page 410.	[AIV2 Sensor Config.] <i>, P V 2 -</i>
[OutletPres Assign] <i>P S 2 R</i> is set to [AI Virtual 2] <i>R , V 2</i>	-	[AIV2 Sensor Config.] <i>o C V 2 -</i>
	[Sleep Detect Mode] <i>S L P I</i> is set to [Pressure] <i>H P</i> or [Multiple] <i>o r</i> , page 327.	[AIV2 Sensor Config.] <i>S o V 2 -</i>
	[Wake Up Mode] <i>W U P I</i> is set to [Pressure] <i>L P</i> , page 327.	[AIV2 Sensor Config.] <i>W o V 2 -</i>
	[Activation Mode] <i>P F I</i> is set to [Outlet Pressure] <i>P S 2 .</i> , page 363	[AIV2 Sensor Config.] <i>P F V 2 -</i>
	[OutPres Monitoring] <i>o P P I</i> is set to [Sensor] <i>S n S r</i> or [Both] <i>b o t h</i> , page 415.	[AIV2 Sensor Config] <i>o o V 2 -</i>
[Inst. Flow Assign.] <i>F S I R</i> is set to [AI Virtual 2] <i>R , V 2</i>	-	[AIV2 Sensor Config.] <i>, F V 2 -</i>
	[LevelCtrl Strategy] <i>L C S E</i> is set to [Energy Optimized] <i>R d V</i> , page 281.	[AIV2 Sensor Config.] <i>L , V 2 -</i>
	[Sleep Detect Mode] <i>S L P I</i> is set to [Flow] <i>L F</i> or [Multiple] <i>o r</i> , page 327.	[AIV2 Sensor Config.] <i>S , V 2 -</i>
	[Mode Selection] <i>F L C I</i> is not set to [Inactive] <i>n o</i> , page 368.	[AIV2 Sensor Config.] <i>F , V 2 -</i>
	[Flow limitation Mode] <i>F L I</i> is not set to [No] <i>n o</i> , page 379.	[AIV2 Sensor Config.] <i>L F V 2 -</i>
	[HighFlow Activation] <i>H F P I</i> is not set to [No] <i>n o</i> , page 420.	[AIV2 Sensor Config.] <i>H , V 2 -</i>
	<ul style="list-style-type: none"> [Booster Control] <i>b C I</i> is set to [Yes] <i>Y E S</i> [Booster S/D Condition] <i>b S d C</i> is set to [Speed +Flow] <i>S P F L</i> , page 244. 	[AIV2 Sensor Config.] <i>b , V 2 -</i>
[Pump Flow Assign.] <i>F S 2 R</i> is set to [AI Virtual 2] <i>R , V 2</i>	-	[AIV2 Sensor Config.] <i>P F V 2 -</i>

If...	And...	Then following menu will be displayed:
	[PumpLF Monitoring] <i>P L F Π</i> is set to [Flow] <i>q</i> or [Flow vs Speed] <i>q n</i> , page 403.	[AIV2 Sensor Config.] <i>n P V 2 -</i>
[Level Sensor Assign] <i>L C S R</i> is set to [AI Virtual 2] <i>R , V 2</i>	[Pump functions] - [Level control] , page 281.	[AIV2 Sensor Config.] <i>L C V 2 -</i>
NOTE: The list of parameters is the same for each [AIV2 Sensor Config.] menu.		

[AIV2 Channel Assignment] *R , C 2*

Channel assignment for virtual analog input AIV2.

Identical to **[AIV1 Channel Assignment]** *R , C 1*, page 223.

[AIV2 Lowest Process] *R u 2 J*

AI virtual 2: minimum process value.

Identical to **[AIV1 Lowest Process]** *R u 1 J*, page 223.

[AIV2 Highest Process] *R u 2 K*

AI virtual 2: maximum process value.

Identical to **[AIV1 Highest Process]** *R u 1 K*, page 223.

[AIV3 configuration] Menu

About This Menu

Access of **[AIV3 Sensor Config.]** menu depends of the sensor assigned to this input.

The following table shows the **[AIV3 Sensor Config.]** menus displayed in relation with the sensor and the applicative function used.

If...	And...	Then following menu will be displayed:
[InletPres Assign] P 5 I R is set to [AI Virtual 3] R , V 3	-	[AIV3 Sensor Config.] , C V 3 -
	[Priming Pump Assign] P P o R is not set to [No] n o , page 375	[AIV3 Sensor Config.] P P V 3 -
	[InletPres Monitoring] , P P n is not set to [No] n o , page 410	[AIV3 Sensor Config.] , P V 3 -
[OutletPres Assign] P 5 2 R is set to [AI Virtual 3] R , V 3	-	[AIV3 Sensor Config.] o C V 3 -
	[Sleep Detect Mode] S L P n is set to [Pressure] H P or [Multiple] o r . , page 327	[AIV3 Sensor Config.] S o V 3 -
	[Wake Up Mode] W u P n is set to [Pressure] L P . , page 327	[AIV3 Sensor Config.] W o V 3 -
	[Activation Mode] P F n is set to [Outlet Pressure] P 5 2 . , page 363	[AIV3 Sensor Config.] P F V 3 -
	[OutPres Monitoring] o P P n is set to [Sensor] S n S r or [Both] b o t h . , page 415	[AIV3 Sensor Config] o o V 3 -
[Inst. Flow Assign.] F 5 I R is set to [AI Virtual 3] R , V 3	-	[AIV3 Sensor Config.] , F V 3 -
	[LevelCtrl Strategy] L C 5 E is set to [Energy Optimized] R d V . , page 281	[AIV3 Sensor Config.] L , V 3 -
	[Sleep Detect Mode] S L P n is set to [Flow] L F or [Multiple] o r . , page 327	[AIV3 Sensor Config.] S , V 3 -
	[Mode Selection] F L C n is not set to [Inactive] n o . , page 368	[AIV3 Sensor Config.] F , V 3 -
	[Flow limitation Mode] F L n is not set to [No] n o . , page 379	[AIV3 Sensor Config.] L F V 3 -
	[HighFlow Activation] H F P n is not set to [No] n o .	[AIV3 Sensor Config.] H , V 3 -

If...	And...	Then following menu will be displayed:
	, page 420	
	<ul style="list-style-type: none"> • [Booster Control] b C n is set to [Yes] 4 E 5 • [Booster S/D Condition] b 5 d C is set to [Speed +Flow] 5 P F L . , page 244	[AIV3 Sensor Config.] b , v 3 -
[Pump Flow Assign.] F 5 2 R is set to [AI Virtual 3] R , v 3	-	[AIV3 Sensor Config.] P F v 3 -
	[PumpLF Monitoring] P L F n is set to [Flow] 9 or [Flow vs Speed] 9 n . , page 403	[AIV3 Sensor Config.] n P v 3 -
[Level Sensor Assign] L C 5 R is set to [AI Virtual 3] R , v 3	, page 281	[AIV3 Sensor Config.] L C v 3 -
NOTE: The list of parameters is the same for each [AIV3 Sensor Config.] menu.		

[AIV3 Channel Assignment] R , C 3

Channel assignment for virtual analog input AIV3.

Identical to **[AIV1 Channel Assignment] R , C 1** , page 223.

[AIV3 Lowest Process] R u 3 J

AI virtual 3: minimum process value.

Identical to **[AIV1 Lowest Process] R u 1 J** , page 223.

[AIV3 Highest Process] R u 3 K

AI virtual 3: maximum process value.

Identical to **[AIV1 Highest Process] R u 1 K** , page 223.

[Command and Reference] \llcorner \llcorner \llcorner - Menu

[Command and Reference] \llcorner \llcorner \llcorner - Menu

Access

[Complete settings] → [Command and Reference]

Command and Reference Channels Parameter Can Be Accessed

Run commands (forward, reverse, stop, and so on) and references can be sent using the following channels:

Command	Reference
Terminals: Digital inputs DI	Terminals: Analog inputs AI, pulse input
Graphic Display Terminal	Graphic Display Terminal
Integrated Modbus	Integrated Modbus
CANopen®	CANopen
Fieldbus module	Fieldbus module
-	+/- speed via the Graphic Display Terminal
Integrated Ethernet Modbus TCP	Integrated Ethernet Modbus TCP

NOTE: The stop keys on the Graphic Display Terminal can be programmed as non-priority keys. A stop key can only have priority if the **[Stop Key Enable] P 5 E** parameter menu is set to **[Stop Key Priority] 9 E 5** or **[Stop Key Priority All] R L L**.

The behavior of the drive can be adapted according to requirements:

- **[Not separ.] 5 , 7 :** Command and reference are sent via the same channel.
- **[Separate] 5 E P :** Command and reference may be sent via different channels. In these configurations, control via the communication bus is performed in accordance with the DRIVECOM standard with only 5 freely assignable bits (see communication parameter manual). The application functions cannot be accessed via the communication interface.
- **[I/O profile] , 0 :** The command and the reference can come from different channels. This configuration both simplifies and extends use via the communication interface. Commands may be sent via the digital inputs on the terminals or via the communication bus. When commands are sent via a bus, they are available on a word, which acts as virtual terminals containing only digital inputs. Application functions can be assigned to the bits in this word. More than one function can be assigned to the same bit.

NOTE: Stop commands from the Graphic Display Terminal remain active even if the terminals are not the active command channel.

Reference Channel for [Not separ.] 5 1 1, [Separate] 5 EP and [I/O profile] 1 0 Configurations, PID Configured with PID References at the Terminals

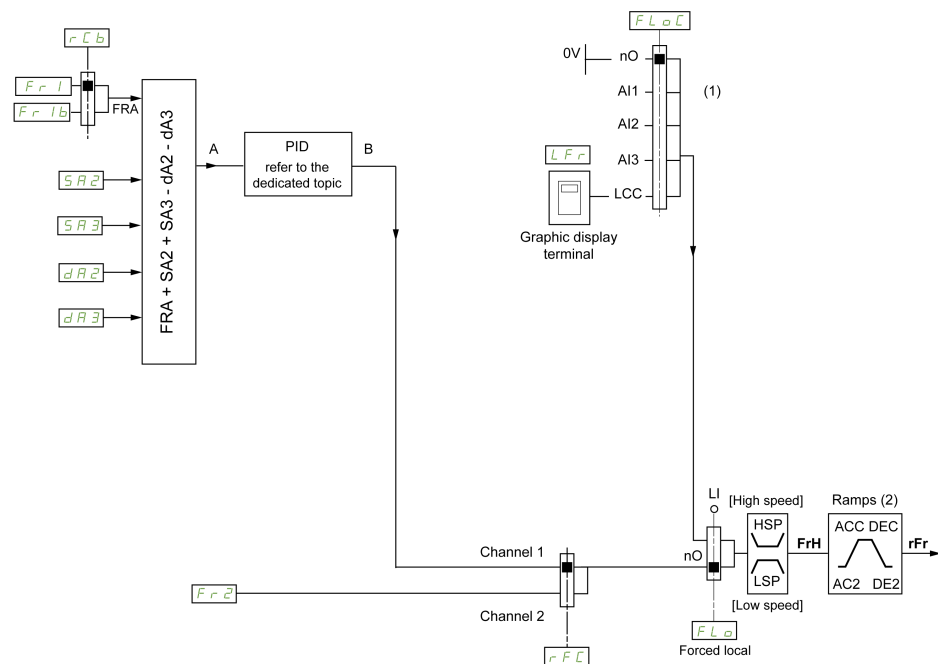

(1) Note: Forced local is not active in [I/O profile].

(2) Ramps not active if the PID function is active in automatic mode.

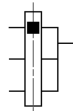

The black square represents the factory setting assignment.

Fr 1: terminals (including I/O extension module), Graphic Display Terminal, integrated Modbus, CANopen®, embedded Ethernet, and fieldbus module.

Fr 1b, for **5 EP** and **1 0**: terminals (including I/O extension module), Graphic Display Terminal, integrated Modbus, CANopen®, embedded Ethernet, and fieldbus module.

Fr 1b, for **5 1 1**: Graphic Display Terminal, only accessible if **Fr 1** = terminals.

SA 2, SA 3, dA 2, dA 3: terminals (including I/O extension module), Graphic Display Terminal, integrated Modbus, CANopen®, embedded Ethernet, and fieldbus module.

Fr 2: terminals (including I/O extension module), Graphic Display Terminal, integrated Modbus, CANopen®, embedded Ethernet, +/- speed, and fieldbus module.

Command Channel for [Not separ.] 5 1 1 configuration

Reference and command, not separate.

The command channel is determined by the reference channel. The parameters **Fr 1, Fr 2, rFc, FL 0** and **FL 0C** are common to reference and command.

Example: If the reference is **Fr 1 = AI 1** (analog input at the terminals), control is via DI (digital input at the terminals).

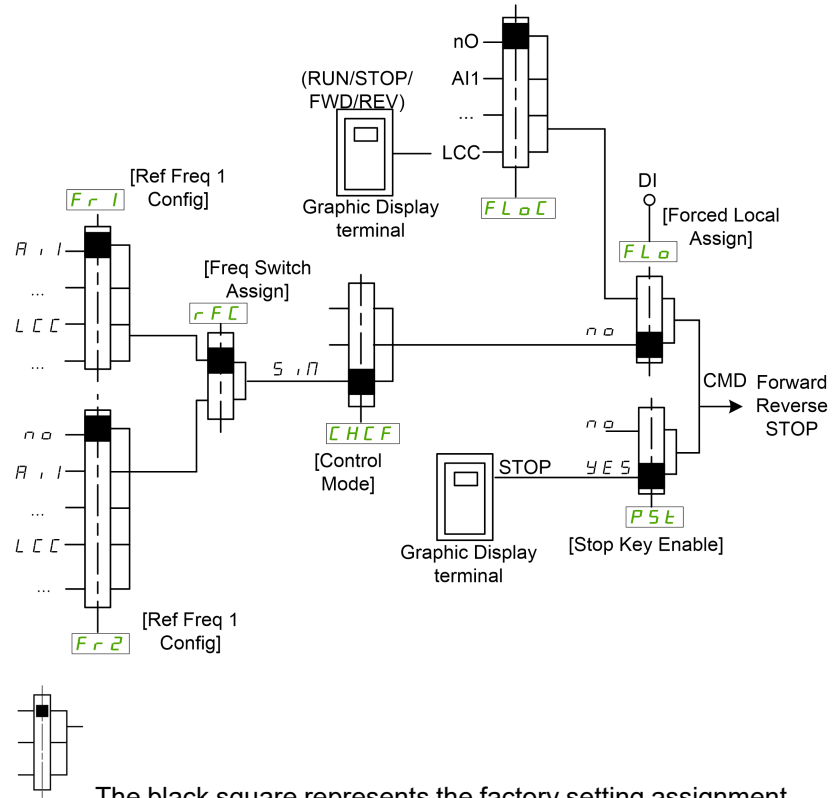

Command Channel for [Separate] *S E P* configuration

Separated Reference and command.

The parameters *F L o* and *F L o C* are common to reference and command.

Example: If the reference is in forced local mode via AI1 (analog input at the terminals), command in forced local mode is via DI (digital input at the terminals).

The command channels *C d 1* and *C d 2* are independent of the reference channels *F r 1*, *F r 1 b* and *F r 2*.

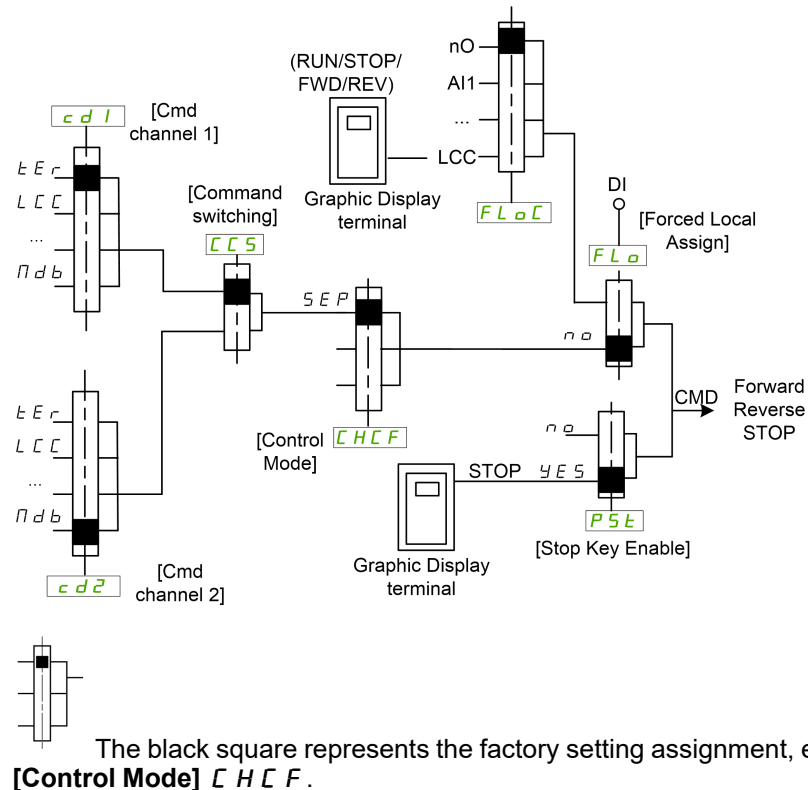

[Cmd channel 1] C d 1 and [Cmd channel 2] C d 2: Terminals, Graphic Display Terminal, integrated Modbus, integrated CANopen®, communication card

Command Channel for I/O profile I O configuration

Separated Reference and command, as in [Separate] 5 E P configuration.

The command channels C d 1 and C d 2 are independent of the reference channels F r 1, F r 1 b and FR2.

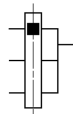
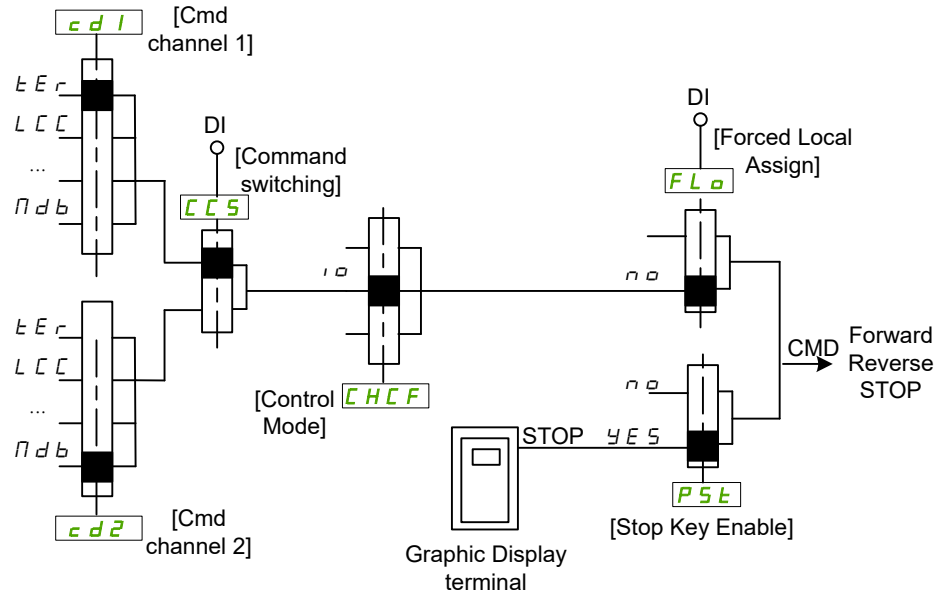

The black square represents the factory setting assignment, except for [Control Mode] C H C F.

[Cmd channel 1] C d 1 and [Cmd channel 2] C d 2: Terminals, Graphic Display Terminal, integrated Modbus, integrated CANopen®, communication card

A command or an action can be assigned:

- To a fixed channel by selecting a Digital input (Dix) or a Cxxx bit:
 - By selecting, for example, LI3, this action will be triggered by the digital input DI3 regardless of which command channel is switched.
 - By selecting, for example, C114, this action will be triggered by integrated Modbus with bit 14 regardless of which command channel is switched.
- To a switchable channel by selecting a CDxx bit:
 - By selecting, for example, Cd11, this action will be triggered by: LI12 if the terminals channel is active, C111 if the integrated Modbus channel is active, C211 if the integrated CANopen® channel is active, C311 if the communication card channel is active, C511 if the Ethernet channel is active.

If the active channel is the graphic display terminal, the functions and commands assigned to CDxx switchable internal bits are inactive.

NOTE: Several CDxx does not have equivalent digital inputs and can only be used for switching between 2 networks.

[Ref Freq 1 Config] F r 1

Configuration reference frequency 1.

Setting	Code / Value	Description
[Not Configured]	<i>n o</i>	Not assigned
[AI1]	<i>A , 1</i>	Analog input AI1 Factory Setting
[AI2]...[AI3]	<i>A , 2 ... A , 3</i>	Analog input AI2...AI3
[AI Virtual 1]...[AI Virtual 3]	<i>A , V 1 ... A , V 3</i>	Virtual analogic input 1...3
[AI4]...[AI5]	<i>A , 4 ... A , 5</i>	Analog input AI4...AI5 if VW3A3203 I/O extension module has been inserted
[Ref.Freq-Rmt. Term]	<i>ℓ ℓ ℓ</i>	Reference Frequency via remote terminal
[Ref. Freq-Modbus]	<i>Π d b</i>	Reference frequency via Modbus
[Ref. Freq-CANopen]	<i>ℓ A n</i>	Reference frequency via CANopen if a CANopen module has been inserted
[Ref. Freq-Com. Module]	<i>n E ℓ</i>	Reference frequency via fieldbus module if a fieldbus module has been inserted
[Embedded Ethernet]	<i>E ℓ H</i>	Embedded Ethernet
[DI5 PulseInput Assignment]... [DI6 PulseInput Assignment]	<i>P , 5 ... P , 6</i>	Digital input DI5...DI6 used as pulse input

[Ref.1B channel] *F r 1 b*

Configuration reference frequency 1B.

Identical to **[Ref Freq 1 Config] *F r 1*** (see above) with factory setting: **[Not Configured] *n o***.

[Ref 1B switching] *r ℓ b*

⚠ WARNING
UNANTICIPATED EQUIPMENT OPERATION
This parameter can cause unintended movements, for example, inversion of the direction of rotation of the motor, sudden acceleration or stops.
<ul style="list-style-type: none"> • Verify that the setting of this parameter does not cause unintended movements. • Verify that the setting of this parameter does not result in unsafe conditions.
Failure to follow these instructions can result in death, serious injury, or equipment damage.

Select switching (1 to 1B).

- If the assigned input or bit is at *D*, **[Ref Freq 1 Config] *F r 1*** is active.
- If the assigned input or bit is at *I*, **[Ref.1B channel] *F r 1 b*** is active.

[Ref 1B switching] *r ℓ b* is forced to **[Ref Freq Channel 1] *F r 1*** if **[Control Mode] *ℓ H ℓ F*** is set to **[Not separ.] *5 , Π*** with **[Ref Freq 1 Config] *F r 1*** assigned via the terminals (analog inputs, pulse input).

NOTE: Activating this function from an other active command channel will also activate the monitoring of this new channel.

Setting	Code / Value	Description
[Ref Freq Channel 1]	<i>F r 1</i>	Reference channel = channel 1 (for RCB)
[Ref.1B channel]	<i>F r 1 b</i>	Reference channel = channel 1b (for RCB)
[DI1]...[DI6]	<i>L i 1...L i 6</i>	Digital input DI1...DI6
[DI11]...[DI16]	<i>L i 1 1... L i 1 6</i>	Digital input DI11...DI16 if VW3A3203 I/O extension module has been inserted
[CD00]... [CD10]	<i>C d 0 0... C d 1 0</i>	Virtual digital input CMD.0...CMD.10 in [I/O profile] , <i>o</i> configuration
[CD11]... [CD15]	<i>C d 1 1... C d 1 5</i>	Virtual digital input CMD.11...CMD.15 regardless of configuration
[C101]... [C110]	<i>C 1 0 1... C 1 1 0</i>	Virtual digital input CMD1.01...CMD1.10 with integrated Modbus Serial in [I/O profile] , <i>o</i> configuration
[C111]... [C115]	<i>C 1 1 1... C 1 1 5</i>	Virtual digital input CMD1.11...CMD1.15 with integrated Modbus Serial regardless of configuration
[C201]... [C210]	<i>C 2 0 1... C 2 1 0</i>	Virtual digital input CMD2.01...CMD2.10 with CANopen® fieldbus module in [I/O profile] , <i>o</i> configuration
[C211]... [C215]	<i>C 2 1 1... C 2 1 5</i>	Virtual digital input CMD2.11...CMD2.15 with CANopen® fieldbus module regardless of configuration
[C301]... [C310]	<i>C 3 0 1... C 3 1 0</i>	Virtual digital input CMD3.01...CMD3.10 with a fieldbus module in [I/O profile] , <i>o</i> configuration
[C311]... [C315]	<i>C 3 1 1... C 3 1 5</i>	Virtual digital input CMD3.11...CMD3.15 with a fieldbus module regardless of configuration
[C501]... [C510]	<i>C 5 0 1... C 5 1 0</i>	Virtual digital input CMD5.01...CMD5.10 with integrated Ethernet in [I/O profile] , <i>o</i> configuration
[C511]... [C515]	<i>C 5 1 1... C 5 1 5</i>	Virtual digital input CMD5.11...CMD5.15 with integrated Ethernet regardless of configuration

[Reverse Disable] *r i n*

Reverse directions disable.

NOTE: Anti-Jam function takes priority over [Reverse Disable] *r i n* function. If an Anti jam function is used, reverse direction is applied despite of the [Reverse disable] *r i n* configuration.

Lock of movement in reverse direction does not apply to direction requests sent by digital inputs.

Reverse direction requests sent by digital inputs are taken into account.

Reverse direction requests sent by the Graphic Display Terminal or sent by the line are not taken into account.

Any reverse speed reference originating from the PID, summing input, and so on, is interpreted as a zero reference (0 Hz).

Setting	Code / Value	Description
[No]	n o	<p>Motor rotation direction is defined by the run command [Forward] F r d or [Reverse] r r S and the sign of the reference frequency.</p> <p>When the reference frequency is positive and a:</p> <ul style="list-style-type: none"> [Forward] F r d run command is given: the motor starts in forward direction [Reverse] r r S run command is given: the motor starts in reverse direction <p>When the reference frequency is negative and a:</p> <ul style="list-style-type: none"> [Forward] F r d run command is given: the motor starts in reverse direction [Reverse] r r S run command is given: the motor starts in forward direction
[Yes]	y E S	Any reverse speed reference originating from the PID, summing input, and so on, is interpreted as a zero reference (0 Hz).
[Absolute]	A b S	Motor rotation direction is defined by the run command [Forward] F r d or [Reverse] r r S regardless of the sign of the reference frequency (i.e only the absolute value of the reference frequency is considered).

[Control Mode] C H C F 

Mixed mode configuration.

⚠ WARNING
<p>UNANTICIPATED EQUIPMENT OPERATION</p> <p>Disabling [I/O profile] I O resets the drive to the factory settings.</p> <ul style="list-style-type: none"> Verify that restoring the factory settings is compatible with the type of wiring used. <p>Failure to follow these instructions can result in death, serious injury, or equipment damage.</p>

Setting	Code / Value	Description
[Not separ.]	S , n	Reference and command, not separate Factory Setting
[Separate]	S E P	Separate reference and command. This assignment cannot be accessed in [I/O profile] I O
[I/O profile]	I O	I/O profile

[Command Switching] C C S ★

⚠ WARNING
<p>UNANTICIPATED EQUIPMENT OPERATION</p> <p>This parameter can cause unintended movements, for example, inversion of the direction of rotation of the motor, sudden acceleration or stops.</p> <ul style="list-style-type: none"> Verify that the setting of this parameter does not cause unintended movements. Verify that the setting of this parameter does not result in unsafe conditions. <p>Failure to follow these instructions can result in death, serious injury, or equipment damage.</p>

Control channel switch.

This parameter can be accessed if **[Control Mode] C H C F** is set to **[Separate] S E P** or to **[I/O profile] i o**.

If the assigned input or bit is at 0, channel **[Cmd channel 1] C d 1** is active. If the assigned input or bit is at 1, channel **[Cmd channel 2] C d 2** is active.

NOTE: Activating this function from an other active command channel will also activate the monitoring of this new channel.

Setting	Code / Value	Description
[Command channel 1]	<i>C d 1</i>	Command channel = channel 1 (for CCS) Factory setting
[Command channel 2]	<i>C d 2</i>	Command channel = channel 2 (for CCS)
[DI1]...[DI6]	<i>L 1...L 6</i>	Digital input DI1...DI6
[DI11]...[DI16]	<i>L 11...L 16</i>	Digital input DI11...DI16 if VW3A3203 I/O extension module has been inserted
[C101]... [C110]	<i>C 10 1... C 1 10</i>	Virtual digital input CMD1.01...CMD1.10 with integrated Modbus Serial in [I/O profile] i o configuration
[C111]... [C115]	<i>C 1 1 1... C 1 1 5</i>	Virtual digital input CMD1.11...CMD1.15 with integrated Modbus Serial regardless of configuration
[C201]... [C210]	<i>C 2 0 1... C 2 10</i>	Virtual digital input CMD2.01...CMD2.10 with CANopen® fieldbus module in [I/O profile] i o configuration
[C211]... [C215]	<i>C 2 1 1... C 2 1 5</i>	Virtual digital input CMD2.11...CMD2.15 with CANopen® fieldbus module regardless of configuration
[C301]... [C310]	<i>C 3 0 1... C 3 10</i>	Virtual digital input CMD3.01...CMD3.10 with a fieldbus module in [I/O profile] i o configuration
[C311]... [C315]	<i>C 3 1 1... C 3 1 5</i>	Virtual digital input CMD3.11...CMD3.15 with a fieldbus module regardless of configuration
[C501]... [C510]	<i>C 5 0 1... C 5 10</i>	Virtual digital input CMD5.01...CMD5.10 with integrated Ethernet in [I/O profile] i o configuration
[C511]... [C515]	<i>C 5 1 1... C 5 1 5</i>	Virtual digital input CMD5.11...CMD5.15 with integrated Ethernet regardless of configuration

[Cmd channel 1] C d 1 ★

Command channel 1 assignment.

This parameter can be accessed if **[Control Mode] C H C F** is set to **[Separate] S E P** or **[I/O profile] i o**.

Setting	Code / Value	Description
[Terminals]	<i>t e r</i>	Terminal block source Factory Setting
[Ref.Freq-Rmt. Term]	<i>L C C</i>	Command via Graphic Display Terminal
[Ref. Freq-Modbus]	<i>m d b</i>	Command via Modbus
[Ref. Freq-CANopen]	<i>C A n</i>	Command via CANopen if a CANopen module has been inserted
[Ref. Freq-Com. Module]	<i>n e t</i>	Command via fieldbus module if a fieldbus module has been inserted
[Embedded Ethernet]	<i>E t H</i>	Command via Embedded Ethernet

[Cmd channel 2] C d 2★

Command channel 2 assignment.

This parameter can be accessed if [Control Mode] C H C F is set to [Separate] S E P or [I/O profile] i o.

Identical to [Cmd channel 1] C d 1 with factory setting [Ref. Freq-Modbus] n d b.

[Freq Switch Assign] r F C

⚠ WARNING

UNANTICIPATED EQUIPMENT OPERATION

This parameter can cause unintended movements, for example, inversion of the direction of rotation of the motor, sudden acceleration or stops.

- Verify that the setting of this parameter does not cause unintended movements.
- Verify that the setting of this parameter does not result in unsafe conditions.

Failure to follow these instructions can result in death, serious injury, or equipment damage.

frequency switching assignment.

If the assigned input or bit is at 0, channel [Ref Freq Channel 1] F r 1 is active.

If the assigned input or bit is at 1, channel [Ref Freq Channel 2] F r 2 is active.

NOTE: Activating this function from an other active command channel will also activate the monitoring of this new channel.

Setting	Code / Value	Description
[Ref Freq Channel 1]	F r 1	Reference channel = channel 1 (for RFC)
[Ref Freq Channel 2]	F r 2	Reference channel = channel 2 (for RFC)
[DI1]...[DI6]	L , 1...L , 6	Digital input DI1...DI6
[DI11]...[DI16]	L , 11... L , 16	Digital input DI11...DI16 if VW3A3203 I/O extension module has been inserted
[CD00]... [CD10]	C d 0 0... C d 1 0	Virtual digital input CMD.0...CMD.10 in [I/O profile] i o configuration
[CD11]... [CD15]	C d 1 1... C d 1 5	Virtual digital input CMD.11...CMD.15 regardless of configuration
[C101]... [C110]	C 1 0 1... C 1 1 0	Virtual digital input CMD1.01...CMD1.10 with integrated Modbus Serial in [I/O profile] i o configuration
[C111]... [C115]	C 1 1 1... C 1 1 5	Virtual digital input CMD1.11...CMD1.15 with integrated Modbus Serial regardless of configuration
[C201]... [C210]	C 2 0 1... C 2 1 0	Virtual digital input CMD2.01...CMD2.10 with CANopen® fieldbus module in [I/O profile] i o configuration
[C211]... [C215]	C 2 1 1... C 2 1 5	Virtual digital input CMD2.11...CMD2.15 with CANopen® fieldbus module regardless of configuration
[C301]... [C310]	C 3 0 1... C 3 1 0	Virtual digital input CMD3.01...CMD3.10 with a fieldbus module in [I/O profile] i o configuration
[C311]... [C315]	C 3 1 1... C 3 1 5	Virtual digital input CMD3.11...CMD3.15 with a fieldbus module regardless of configuration

Setting	Code / Value	Description
[C501]... [C510]	C 5 0 1... C 5 1 0	Virtual digital input CMD5.01...CMD5.10 with integrated Ethernet in [I/O profile] configuration
[C511]... [C515]	C 5 1 1... C 5 1 5	Virtual digital input CMD5.11...CMD5.15 with integrated Ethernet regardless of configuration

[Ref Freq 2 Config] F r 2

Configuration reference frequency 2.

Setting	Code / Value	Description
[Not Configured]	n o	Not assigned. If [Control Mode] C H C F is set to [Not separ.] S , P, the command is at the terminals with a zero reference. If [Control Mode] C H C F is set to [Separate] S E P or [I/O profile] i o, the reference is zero. Factory Setting
[AI1]...[AI3]	R i 1...R i 3	Analog input AI1...AI3
[AI4]...[AI5]	R i 4...R i 5	Analog input AI4...AI5 if VW3A3203 I/O extension module has been inserted
[AI Virtual 1]... [AI Virtual 3]	R i V 1... R i V 3	Virtual analogic input 1...3
[Ref Frequency via DI]	u P d t	+/- speed command assigned to DIx
[Ref.Freq-Rmt.Term]	L C C	Reference frequency via Graphic Display Terminal
[Ref. Freq-Modbus]	M d b	Reference frequency via Modbus
[Ref. Freq-CANopen]	C A n	Reference frequency via CANopen if a CANopen module has been inserted
[Ref. Freq-Com. Module]	n E t	Reference frequency via fieldbus module if a fieldbus module has been inserted
[Embedded Ethernet]	E t h	Integrated Ethernet
[PulseInput Assignment On DI5]... [PulseInput Assignment On DI6]	P i 5...P i 6	Digital input DI5...DI6 used as pulse input

[Copy Ch1-Ch2] C o P

Copy channel 1 reference frequency to channel 2.

⚠ WARNING
<p>UNANTICIPATED EQUIPMENT OPERATION</p> <p>This parameter can cause unintended movements, for example, inversion of the direction of rotation of the motor, sudden acceleration or stops.</p> <ul style="list-style-type: none"> • Verify that the setting of this parameter does not cause unintended movements. • Verify that the setting of this parameter does not result in unsafe conditions. <p>Failure to follow these instructions can result in death, serious injury, or equipment damage.</p>

Can be used to copy the current reference and/or the command with switching in order to avoid speed surges, for example.

If [Control Mode] C H C F , page 235 is set to [Not separ.] S , Π or [Separate] S E P , copying is possible only from channel 1 to channel 2.

If [Control Mode] C H C F is set to [I/O profile] , ρ , copying is possible in both directions. A reference or a command cannot be copied to a channel on the terminals. The reference copied is [Pre-Ramp Ref Freq] F r H (before ramp) unless the destination channel reference is set via +/- speed. In this case, the reference copied is [Output frequency] r F r (after ramp).

Setting	Code / Value	Description
[No]	n ρ	No copy Factory Setting
[Reference Frequency]	S P	Copy reference
[Command]	C d	Copy command
[Cmd + Ref Frequency]	R L L	Copy reference and command

As the Graphic Display Terminal may be selected as the command and/or reference channel, its action modes can be configured.

Comments:

- The Graphic Display Terminal command/reference is only active if the command and/or reference channels from the terminal are active except for BMP with Local/ Remote key (command via the Graphic Display Terminal), which takes priority over these channels. Press Local/ Remote key again to revert control to the selected channel.
- Command and reference via the Graphic Display Terminal are impossible if the latter is connected to more than one drive.
- The preset PID reference functions can only be accessed if [Control Mode] C H C F is set to [Not separ.] S , Π or [Separate] S E P .
- The command via the Graphic Display Terminal can be accessed regardless of the [Control Mode] C H C F .

[Forced Local Freq] F L ρ C

Forced local reference source assignment.

Setting	Code / Value	Description
[Not Configured]	n ρ	Not assigned (control via the terminals with zero reference) Factory Setting
[AI1]...[AI3]	R , 1...R , 3	Analog input AI1...AI3
[AI4]...[AI5]	R , 4...R , 5	Analog input AI4...AI5 if VW3A3203 I/O extension module has been inserted
[Ref.Freq-Rmt.Term]	L C C	Graphic Display Terminal
[PulseInput Assignment On DI5]... [PulseInput Assignment On DI6]	P , 5...P , 6	Digital input DI5...DI6 used as pulse input

[Time-out Forc. Local] FL0t ★

Time for channel confirmation after forced local.

This parameter can be accessed if **[Forced Local Assign] FL0** is not set to **[No] no**.

Setting (°)	Description
0.1...30.0 s	Setting range Factory setting: 10.0 s

[Forced Local Assign] FL0

Forced local assignment.

Forced local mode is active when the input is at state 1.

[Forced Local Assign] FL0 is forced to **[No] no** if **[Control Mode] CHCF** is set to **[I/O profile] io**.

Setting	Code / Value	Description
[Not Assigned]	no	Not assigned Factory setting
[DI1]...[DI6]	L1...L6	Digital input DI1...DI6
[DI11]...[DI16]	L11...L16	Digital input DI11...DI16 if VW3A3203 I/O extension module has been inserted
[DI52 (High level)]... [DI59 (High level)]	d52H...d59H	Cabinet high level assignment digital inputs NOTE: This selection can be accessed on ATV660 and ATV680 equipped with Cabinet IO.

[Reverse Assign] rr5

Reverse assignment.

Setting	Code / Value	Description
[Not Assigned]	no	Not assigned Factory setting
[DI1]...[DI6]	L1...L6	Digital input DI1...DI6
[DI11]...[DI16]	L11...L16	Digital input DI11...DI16 if VW3A3203 I/O extension module has been inserted
[CD00]... [CD10]	cd00...cd10	Virtual digital input CMD.0...CMD.10 in [I/O profile] io configuration
[CD11]... [CD15]	cd11...cd15	Virtual digital input CMD.11...CMD.15 regardless of configuration
[C101]... [C110]	c101...c110	Virtual digital input CMD1.01...CMD1.10 with integrated Modbus Serial in [I/O profile] io configuration
[C111]... [C115]	c111...c115	Virtual digital input CMD1.11...CMD1.15 with integrated Modbus Serial regardless of configuration
[C201]... [C210]	c201...c210	Virtual digital input CMD2.01...CMD2.10 with CANopen® fieldbus module in [I/O profile] io configuration
[C211]... [C215]	c211...c215	Virtual digital input CMD2.11...CMD2.15 with CANopen® fieldbus module regardless of configuration
[C301]... [C310]	c301...c310	Virtual digital input CMD3.01...CMD3.10 with a fieldbus module in [I/O profile] io configuration

Setting	Code / Value	Description
[C311]... [C315]	3 1 1... 3 1 5	Virtual digital input CMD3.11...CMD3.15 with a fieldbus module regardless of configuration
[C501]... [C510]	5 0 1... 5 1 0	Virtual digital input CMD5.01...CMD5.10 with integrated Ethernet in [I/O profile] configuration
[C511]... [C515]	5 1 1... 5 1 5	Virtual digital input CMD5.11...CMD5.15 with integrated Ethernet regardless of configuration

[2/3-wire control] 5 5 5 ⏸

2-wire or 3-wire control.

⚠ WARNING

UNANTICIPATED EQUIPMENT OPERATION

If this parameter is changed, the parameters [Reverse Assign] RRS and [2/3-Wire Control] TCC and the assignments of the digital inputs are reset to the factory setting.

- Verify that this change is compatible with the type of wiring used.

Failure to follow these instructions can result in death, serious injury, or equipment damage.

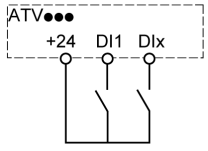
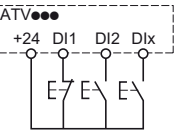
Setting	Code / Value	Description
[2-Wire Control]	2 5	<p>2-wire control (level commands): This is the input state (0 or 1) or edge (0 to 1 or 1 to 0), which controls running or stopping.</p> <p>Example of source wiring:</p>  <p>DI1 Forward DIx Reverse</p> <p>Factory setting</p>
[3-Wire Control]	3 5	<p>3-wire control (pulse commands) [3 wire]: A Stop level command is used to allow enabling a run command through DI2 or DIX or stopping. A forward or reverse pulse is sufficient to command starting.</p> <p>Example of source wiring:</p>  <p>DI1 Stop DI2 Forward DIx Reverse</p>

[2-wire type] 5 5 5 ★ ⏸

Type of 2-wire control.

This parameter can be accessed if [2/3-wire control] 5 5 5 is set to [2-Wire Control] 2 5.

⚠ WARNING**UNANTICIPATED EQUIPMENT OPERATION**

Verify that the parameter setting is compatible with the type of wiring used.

Failure to follow these instructions can result in death, serious injury, or equipment damage.

Setting	Code / Value	Description
[Level]	L E L	State 0 or 1 is taken into account for run (1) or stop (0)
[Transition]	E r n	A change of state (transition or edge) is necessary to initiate operation in order to avoid accidental restarts after a break in the supply mains Factory setting
[Level With Fwd Priority]	P F o	State 0 or 1 is taken into account for run or stop, but the "forward" input takes priority over the "reverse" input

[Stop Key Enable] P 5 L 

STOP/RESET key enable.

Setting this function to No disables the Stop key of the Graphic Display Terminal if the setting of the parameter **[Command Channel] CMDC** is not **[HMI] LCC**

⚠ WARNING**LOSS OF CONTROL**

Only set this parameter to **[Stop Key No Priority] NO** if you have implemented appropriate alternative stop functions.

Failure to follow these instructions can result in death, serious injury, or equipment damage.

If 2-wire control by level is active (parameter **[2/3-Wire Control] TCC** set to 2C and parameter **[2-wire type] TCT** set to LEL or PFO) and the parameter **[Stop Key Enable] PST** is set to ALL, the motor starts if the STOP/RESET key of the Graphic Display Terminal is pressed while a run command is active.

⚠ WARNING**UNANTICIPATED EQUIPMENT OPERATION**

Only set the parameter **[Stop Key Enable] PST** to **[ALL]** in 2-wire control by level after having verified that this setting cannot result in unsafe conditions.

Failure to follow these instructions can result in death, serious injury, or equipment damage.

Irrespective of the configuration of **[Stop Key Enable] P 5 L**, if the active command channel is the Graphic Display Terminal, the STOP/RESET key performs:

- in run, a stop according to the **[Type of stop] 5 L L**,
- in "Operating State Fault", a fault reset command.

The following table gives the behavior of the function when the Graphic Display Terminal is not the active command channel:

Setting	Code / Value	Description
[Stop Key No Priority]	n o	Disables the STOP/RESET key on the Graphic Display Terminal.
[Stop Key Priority]	y e s	Gives priority to the STOP/RESET key on the Graphic Display Terminal. Only the stop function is enabled. The stop is performed in freewheel. Factory Setting
[Stop Key Priority All]	r l l	Gives priority to the STOP/RESET key on the Graphic Display Terminal. The fault reset function and the stop function are enabled. The stop is performed depending on [Type of Stop] 5 5 5 setting value.
<p>NOTE: The Fault Reset function is disabled in Multipoint mode , page 40.</p>		

[HMI cmd.] b n P

HMI command.

Setting	Code / Value	Description
[Stop]	5 5 o P	Stops the drive (although the controlled direction of operation and reference of the previous channel are copied (to be taken into account on the next RUN command))
[Bumpless]	b u n P	Does not stop the drive (the controlled direction of operation and the reference of the previous channel are copied)
[Disabled]	d , 5	Disabled Factory Setting

[Pump functions] - [Booster control]

Introduction

The aim of the booster control function is to maintain the desired pressure or flow at the outlet of the pumps according to the demand by:

- Managing the velocity of the variable speed pump connected to the drive.
- Staging/De-staging the auxiliary fixed speed pumps.

This menu can be accessed if **[Application Selection]** *R P P L* is set to **[Pump Booster Control]** *b o o S L*.

[System Architecture] *Π P 9* - Menu

Access

[Complete settings] → **[Pump functions]** → **[Booster control]** → **[System architecture]**

About This Menu

This menu is used to define the equipment architecture.

The architecture is chosen by setting **[Pump System Archit]** *Π P S R* to:

- **[Single Drive]** *u n d o L*: one variable speed pump and up to five fixed speed pumps
- **[Multi Drives]** *n V S d*: up to six variable speed pumps
- **[Multi Masters]** *n V S d r*: one master variable speed pump and up to five redundant masters or slaves.

In single drive architecture, the total number of pumps is set with **[Nb Of Pumps]** *Π P P n*:

- With lead pump alternation, using interlocked switching relays for all pumps to connect them on mains or on the drive.
- Without lead pump alternation, using digital outputs to command the auxiliary pumps (with soft starters for example). The lead pump is always connected to the drive.

In multiple drives architecture, the number of pumps is set with **[Nb of Devices]** *Π P G n*. Lead pump alternation is not possible in this case.

MultiDrive Link Mechanism

Introduction:

MultiDrive Link function allows direct communication between a drives group.

This communication is done through an Ethernet link between each drives.

Some drive functions can be configured with the MultiDrive Link.

A VW3A3721 Ethernet module must be installed on the ATV600 drive to use MultiDrive Link.

Topology

MultiDrive Link function is an Ethernet based protocol.

It can be used in following topologies:

- Daisy chain
- Star
- Redundant ring with RSTP

More information about topologies is available in ATV600 Ethernet Option Manual.

MultiDrive Link Properties

MultiDrive Link Group:

A MultiDrive Link group can be composed of up to 6 devices.

Each device can be configured as Master or Slave, but only 1 active master must be present at same time in a MultiDrive Link group.

Each drive, must be identified with a unique ID from 1 to the maximum number of devices in the group.

Data Exchange Principle:

Each drive of the MultiDrive Link group sends data to all the drives of its group.

These data are sorted in data groups which are specific for each application used in combination.

These data are sent using UDP frames with multicast IP addressing.

Network Configuration

The MultiDrive Link function uses the following network resources:

- IP address: 239.192.152.143
- UDP ports: 6700 and 6732
- Non routed networks

If the MultiDrive Link function is used over an Ethernet network, it is mandatory to take into account these resources for its configuration.

Only one MultiDrive Link group can be used on a same Ethernet network.

Drive Configuration

Each drive used on a MultiDrive Link group must have an IP address.

This IP address can be set manually or assigned by a DHCP or BOOTP server.

MultiDrive Link Communication Monitoring

A permanent monitoring of the communication is performed by each drive of the MultiDrive Link Group to avoid:

- Execution of the same command
- Corruption of data on the MultiDrive Link group

Duplicate Slave ID:

The following table shows how the function reacts in case of duplicate slave ID detection:

If a Duplicate Slave ID is...	Then...
Detected at the same time in the MultiDrive Link group	<p>It is not possible to identify the valid drive.</p> <p>In this case, both drives:</p> <ul style="list-style-type: none"> • are considered invalid • are unavailable on the MultiDrive Link group • don't send data on the MultiDrive Link group

Pump Cycling Mode

This functionality allows changing the start order of all available pumps in order to manage their wear. There are several ways to perform the pump cycling strategy by setting **[Pump Cycling Mode] P P C**:

- Cycling based on pump order:
 - **[FIFO] F , F 0** mode: pumps are started and stopped in ascending order
 - **[LIFO] L , F 0** mode: pumps are started in ascending order while they are stopped in descending order
- Cycling based on running time:
 - **[Runtime] r t , P E**: the available pump with the lowest running time is started first and the running pump with the highest running time is stopped first.
 - **[Runtime&LIFO] r t L F**: cycling based on a combination of running time and LIFO mode. The available pump with the lowest running time is started first and the running pump started at latest is stopped first.

NOTE: This choice is not available if **[Pump System Archit] P S A** is set to **[Multi Drives] n V S d**.

Lead Pump Alternation

The lead pump alternation function allows permuting the available pumps in order that each pump can become the lead pump (variable speed pump) instead of an auxiliary pump (fixed speed pump).

The lead pump is the first pump to be started and the last pump to be stopped. It is always associated to the variable speed drive.

The function can be activated by setting **[Lead Pump Alternation] P L A**:

- **[No] n 0**: no lead pump alternation, the pump 1 is always the lead pump. The pump cycling is applied only on auxiliary pumps.
- **[Standard] Y E S**: the lead pump is permuted between all available pumps at each pump operation start.
- **[Redundancy] r E d**: lead pump alternation is effective only if the pump 1 is not available.

When lead pump alternation is activated, catch on fly function should be configured to reduce over current when a pump is started as the lead pump while it was running as auxiliary pump before. It is also possible to set **[Pump Ready Delay] P , d** to delay the availability of an auxiliary pump for a new start after it has been stopped.

Automatic Period Cycling

This function is used to balance the duty sharing of all the pumps of the MultiPump architecture.

When using this function, it is recommended to activate the Catch On Fly function. Depending of the value of **[Pump Cycling Mode] P P C**, this function has different behavior:

- If **[Pump Cycling Mode] P P C** is set to **[Runtime] r E , P E**, the pumps alternate according to the differential operating time between the next to stage and next to destage pumps.
- If **[Pump Cycling Mode] P P C** is set to **[FIFO] F , F o**, the pumps alternate periodically with the time defined on **[Pump Auto Cycling] P C P**. However the time period resets in following cases:
 - At each destage
 - On lead pump stage
 - In architectures with 1 variable speed pumps and direct on line pumps, on first auxiliary pump stage whatever the value of **[Lead Pump Alternation] P L A**.

NOTE: This function is not active when **[Pump Cycling Mode] P P C** is set to **[LIFO] L , F o** or **[Runtime&LIFO] r E L F**.

Display Parameters

A set of parameters to display the system is available in **[Display] P o n - [Pump parameters] P P r - [Multipump System] P P S -**:

- The state of the system **[MultiPump State] P P S**.
- The quantity of pumps available **[Available Pumps] P P A n** and the quantity of pump already staged **[Nb of Staged Pumps] P P S n**.
- The number of the pump selected to be the lead pump **[Lead Pump] P L i d**.
- The number of the next pump to be staged **[Next Staged Pump] P n E S** and de-staged **[Next Destaged Pump] P n E d**.
- For each pump (pump 1 in the example):
 - The state **[Pump 1 State] P I S**
 - The type **[Pump 1 Type] P I E**
 - The cumulated run time **[Pump 1 Runtime] P I o t**
 - The cumulated number of starts **[Pump 1 Nb Starts] P I n S**

Example of Architecture Without Lead Pump Alternation and Two Fixed Speed Pumps

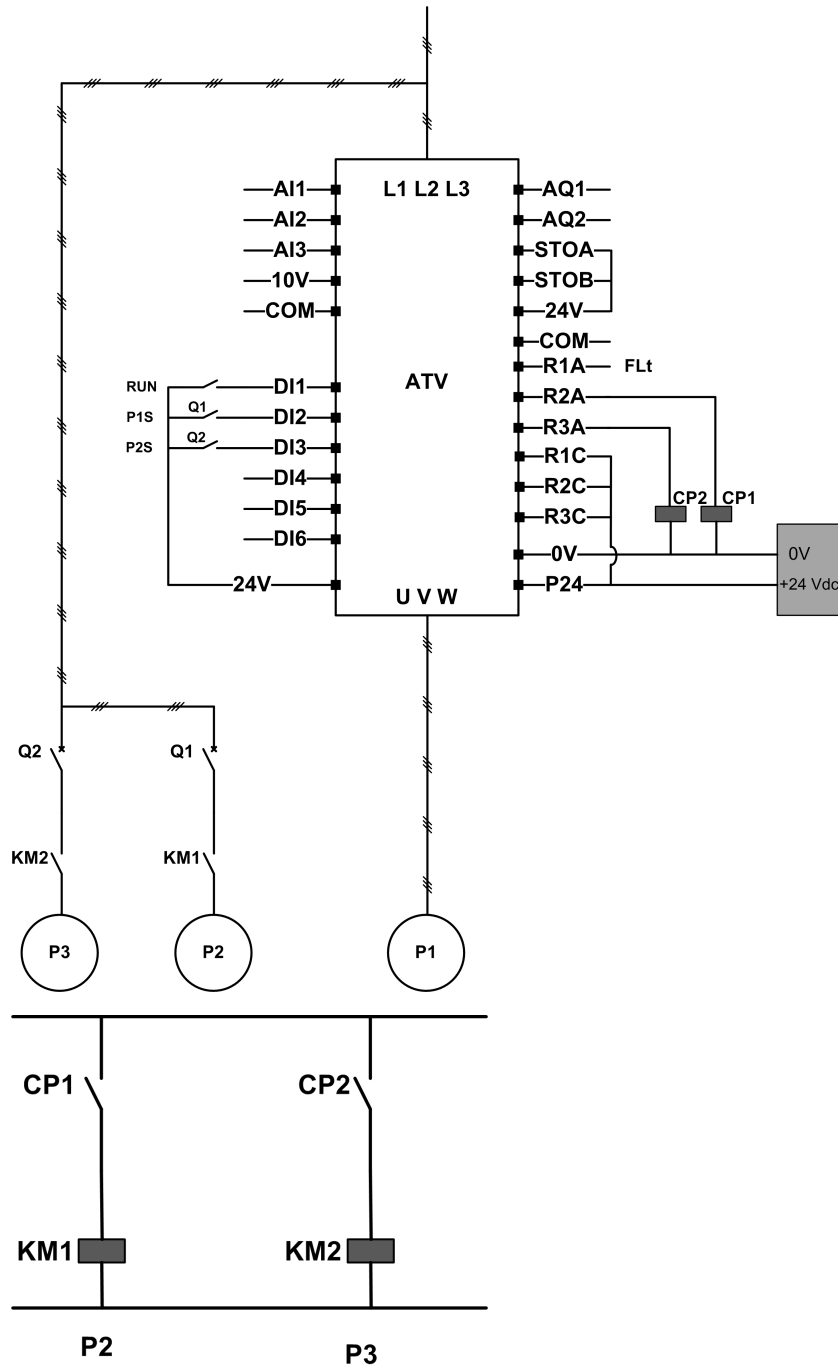

Pump 2 and pump 3 are controlled by relay outputs R2 and R3.

The state of each pump is provided to the drive via digital inputs DI2 and DI3:

- 1 = the pump is ready to operate.
- 0 = the pump is not available.

KM1 is switched ON when CP1 is activated. CP1 is controlled via the relay output R2.

KM2 is switched ON when CP2 is activated. CP2 is controlled via the relay output R3.

Q1 and Q2 must be switched ON to have both pump 2 and pump 3 ready to operate.

Example of Architecture with Lead Pump Alternation on Three Pumps

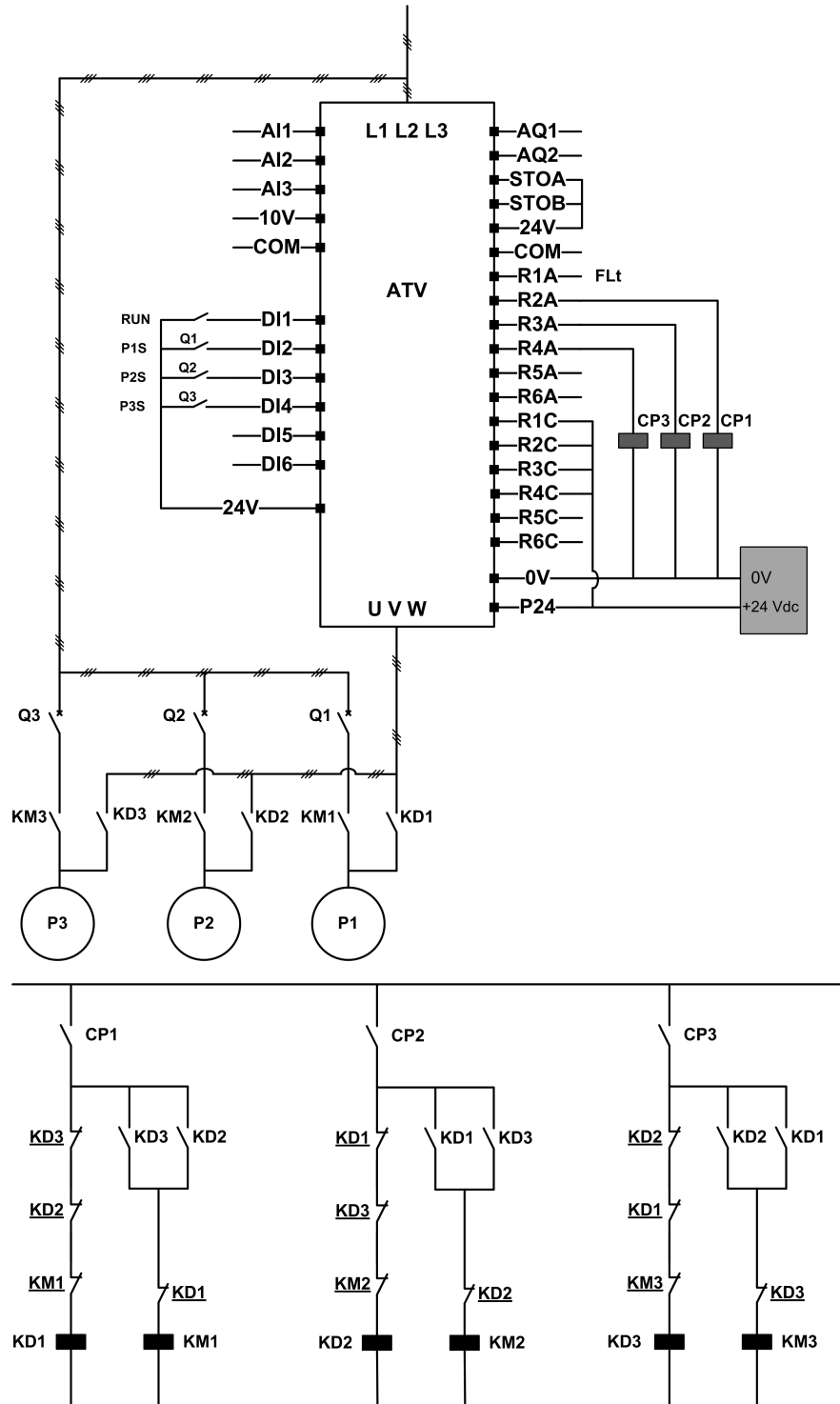

Each pump is controlled by a relay output:

- Pump 1 control via relay output R2.
- Pump 2 control via relay output R3.
- Pump 3 control via relay output R4.

The state of each pump is provided to the drive via digital inputs DI2, DI3, and DI4:

- 1 = the pump is ready to operate.
- 0 = the pump is not available.

If the relay output R2 is the first activated, the pump 1 becomes the lead pump. CP1 is switched ON via relay output R2, KD1 is switched ON and the pump 1 is connected to the drive.

The other pumps cannot be connected to the drive thanks to KD1 (switched OFF) which prevent KD2 and KD3 to be activated when CP2 and CP3 are switched ON. The other pumps become auxiliary pumps and they are connected to the supply mains trough KM2 and KM3 which are activated when, respectively, CP2 and CP3 are switched ON, that is, when R3 and R4 are activated.

When relay output R3 is the first activated, the pump 2 becomes the lead pump. The other pumps become auxiliary pumps which are connected to the supply mains via KM1 and KM3.

When relay output R4 is the first activated, the pump 3 becomes the lead pump. The other pumps become auxiliary pumps which are connected to the supply mains via KM1 and KM2.

Q1, Q2, and Q3 must be switched ON to have all pumps ready to operate.

To change the lead pump, it is necessary to deactivate all relay outputs which means that all pumps must be already stopped. It is then possible to decide which relay output to be activated first and so defining the new lead pump.

Example of Architecture with Lead Pump Alternation on Three Pumps and Auto/Manu Switch

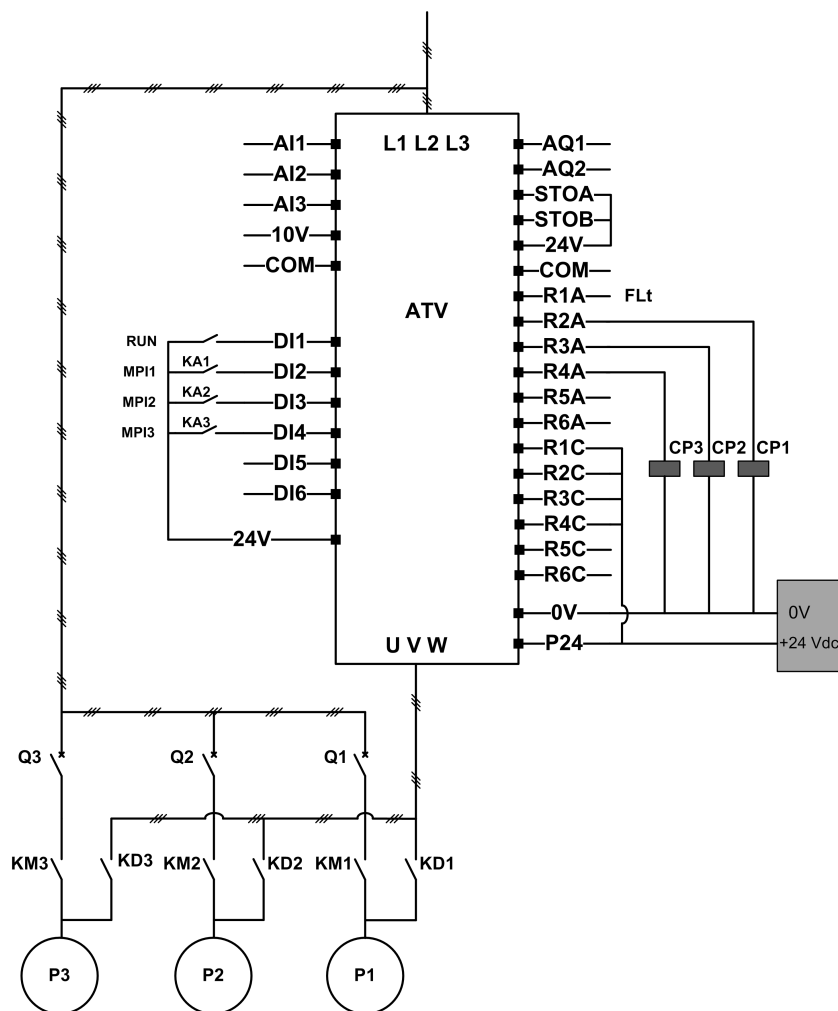

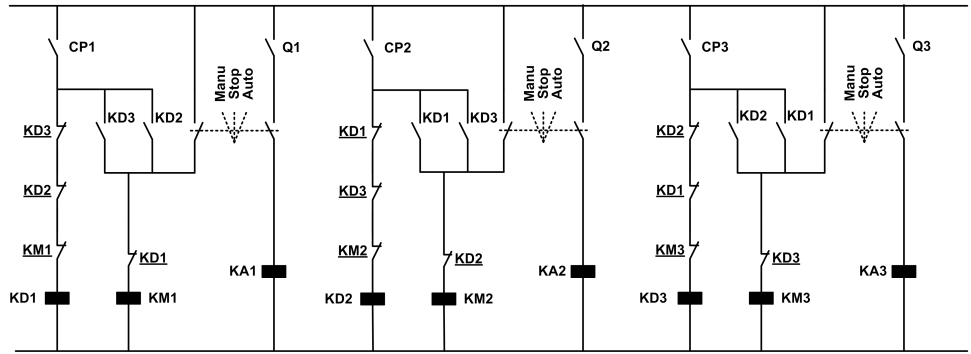

Each pump is controlled by a relay output:

- Pump 1 control via relay output R2.
- Pump 2 control via relay output R3.
- Pump 3 control via relay output R4.

The state of each pump is provided to the drive via digital inputs DI2, DI3, and DI4:

- 1 = the pump is ready to operate.
- 0 = the pump is not available (stopped or in manual mode).

In automatic mode: Same principle as previous architecture with lead pump alternation.

In manual mode: All pumps are connected to the supply mains through KM1, KM2, and KM3.

Example of Architecture with Three Pumps and MultiDrive Link

Each pump is controlled by an ATV600 drive.

The drives are connected together through the MultiDrive link using an Ethernet option module.

Each drive has its own RUN command:

- This command allows the pump to operate.
- On Master drive, this command allows execution of MultiPump functions like Booster and Level Control.

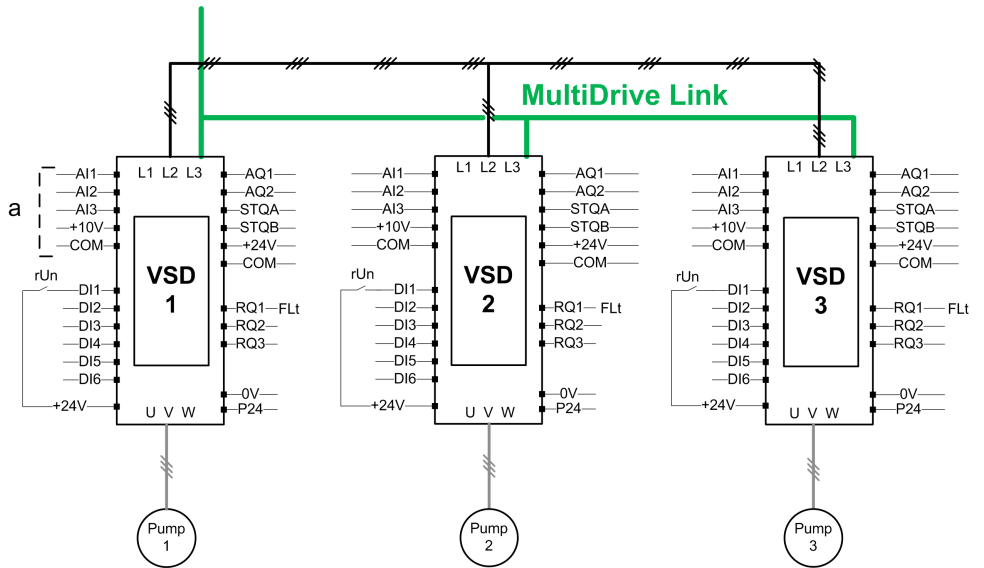

a Sensors connected to the master.

Example of Architecture with Three pumps, MultiDrive Link and Auto/Manu Switch

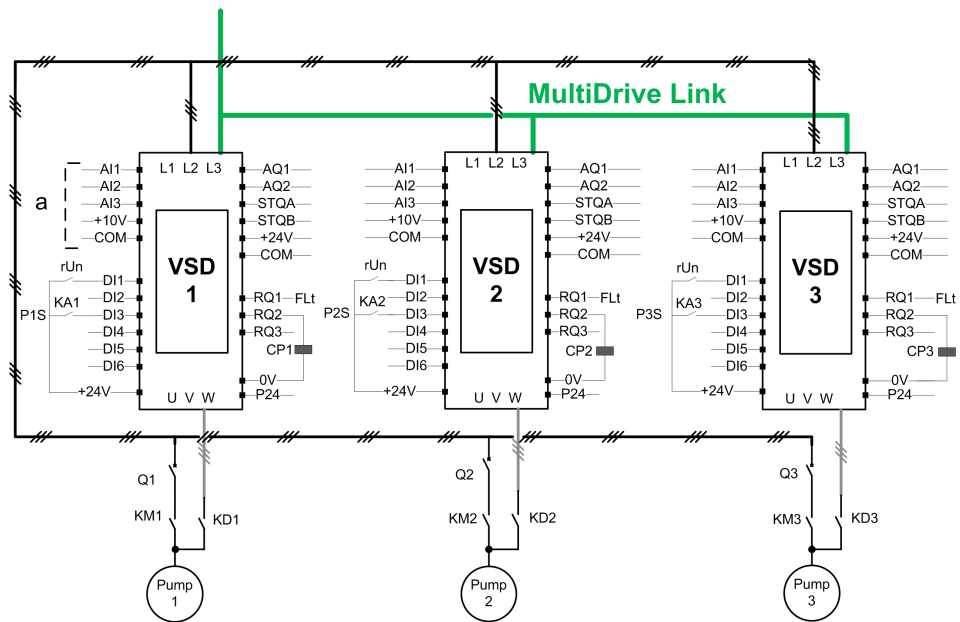

a Sensors connected to the master.

Switching board

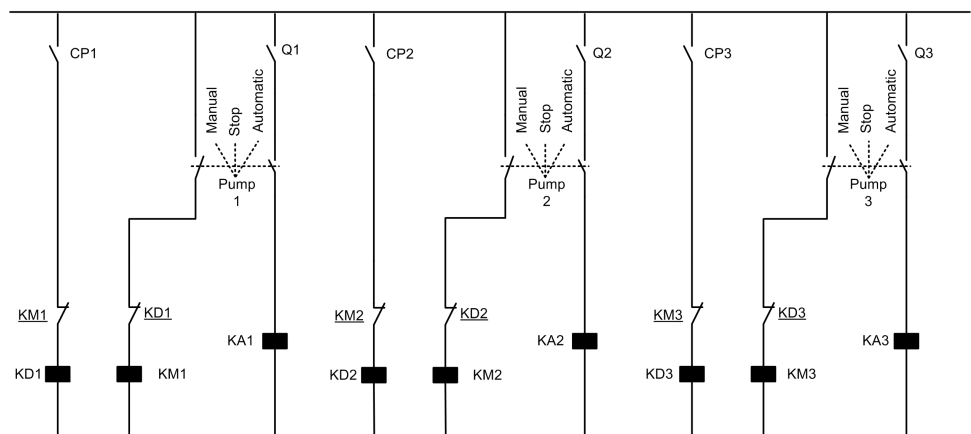

The drives are connected together through the MultiDrive link using a VW3A3721 Ethernet option module.

Each drive has its own RUN command:

- This command allows the pump to operate.
- On Master drive, this command allows execution of MultiPump functions like Booster and Level Control.

The state of each pump is provided to the drive using digital input (DI3 in example).

If this input is set to:

- 1 = the pump is ready to operate in Automatic mode.
- 0 = the pump is not available (Stopped or in Manual mode).

In Automatic mode, the pump is connected and controlled using the ATV600 drive.

In Manual mode, the pump is disconnected from the ATV600 drive and connected to the supply mains.

In Stop mode, the pump is disconnected from both supply mains and ATV600 drive.

Example of Architecture with Three pumps, MultiDrive Link and Service Continuity

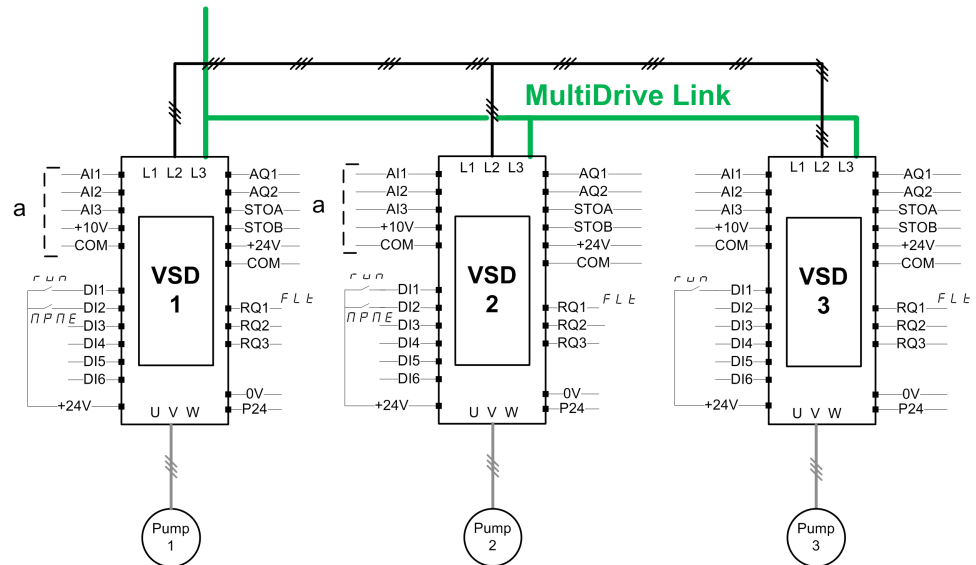

NOTE: Pump 1 = Master, Pump 2: Master or slave, Pump 3: Slave

The drives are connected together through the MultiDrive Link using a VW3A3721 Ethernet option module.

Each drive has its own RUN command:

- This command allows the pump to operate.
- On Master drive, this command allows execution of MultiPump functions like Booster and Level Control.

Each drive of the architecture with [M/P Device Role] $\pi P d E$ set as [Master or Slave] $\pi P S E 2$ can acts as Master.

Master Selection

To allow selection of which drive will acts as Master, the parameter [Master Enable Assign] $\pi P \pi E$ can be configured.

When the input is set to 1, the drive acts as a Master, otherwise, it acts as Slave.

Sensors Wiring

The sensors needed for the application control must be wired on all the drives that can acts as Masters.

Master Election

A drive can be elected as Master if:

- The RUN command is present
- And the drive is not in error state (except for system errors)
- And [Master Enable Assign] $\pi P \pi E$ input is active or not configured.

There is no additional condition on the primary master.

To switch on a secondary master, the primary master must be not available.

A not elected Master acts as a Slave. In this case, Application Control is not executed on it and the error reaction is same as a Slave in architectures without Service Continuity.

At power on, a Master takes the control of the application after the [PwrOn Master Delay] $\pi P P d$ delay if the conditions described above are valid.

When the Master activation conditions are valid, the drive is elected as master of the application after the [Master Act Delay] $\pi P \pi d$ delay. If the [Master Enable

Assign] $\Pi P \Pi E$ is not configured in the architecture, it is recommended to set different delays on the possible masters of the application according to their priority. After election of the Master, the drive activates the output configured on **[Master Active Assign] $\Pi P \Pi A$** parameter.

NOTE: Even if the output is active, it does not mean that the master is active. The MultiDrive Link mechanism will elect one master among all the drives in the architecture and the active master can be identified by **[Active Master ID] $\Pi \Pi \text{ , } d$** .

The status of application is kept when switching from a master to another one.

Following applicative status are taken into account:

- **Sleep/Wake-up:** if the application is woken up
- **Priming Pump:** if the application is primed.

NOTE: In this case the priming pump control have to be wired on each possible masters of the application.

- **Pipe Fill:** if the pipe is filled.

Example: if the master has finished its priming phase, the second one will not restart the priming sequence when it will take the control of the application.

Warnings and Errors Handling

MultiPump Capacity Warning

If the available capacity of the system is exceeded:

- **[MultiPump Capacity Warn] $\Pi P C A$** warning is active if the number of pumps to be started is higher than the number of available pumps.

NOTE: If the number of available pump is equal to 0, the warning is active.

Lead Pump Error/Warning

NOTE: The following handling is done if **[Pump System Architecture] $\Pi P S A$** is set to **[Single Drive] $V n d o L$** .

If the selected lead pump is not available:

- A **[Lead Pump Warn] $\Pi P L A$** warning is active if the lead pump becomes not available while in run or if there is no lead pump available at run command.
- A **[Lead Pump Error] $\Pi P L F$** error is active if the lead pump becomes not available while in run. If configured, the delay **[Pump Ready Delay] $\Pi P \text{ , } d$** is applied on the error triggering if there is no lead pump available at run command.

This error is handled whatever the active command channel if booster control or level control function is configured.

The drive response to a **[Lead Pump Error] $\Pi P L F$** is set with **[MultiPump ErrorResp] $\Pi P F b$** parameter.

MultiPump Device Error/Warning

NOTE: The following handling is done if **[Pump System Architecture] $\Pi P S A$** is set to **[Multi Drives] $n V S d$** or **[Multi Masters] $n V S d r$** .

A device is considered not available by another when no data is received, through MultiDrive Link, for a time longer than **[MDL Comm Timeout] $\Pi L t o$** delay.

- On Master device, the **[M/P Device Warn] $\Pi P d A$** warning is active if one or more Slave devices is not available or not ready.
- On Slave device, the **[M/P Device Warn] $\Pi P d A$** warning is active if the Master device is not available.
- A **[M/P Device Error] $\Pi P d F$** error is active if **[M/P Device Warn] $\Pi P d A$** is active while system is running during more than twice **[Master Act Delay] $\Pi P \Pi d$** delay and a run command is set.

The **[M/P Device Error] n P d F** error can be active only on a device which acts as a Slave.

The drive response to a **[M/P Device Error] n P d F** is set with **[M/P Device ErrorResp] n P d b** parameter.

MultiDrive Link Error

NOTE: The following handling is done if **[Pump System Architecture] n P S A** is set to **[Multi Drives] n V S d**.

- A **[MultiDrive Link Error] n d L F** error is active if the MultiDrive Link architecture is not consistent (several Masters, several Slaves with same ID) at run command.

The drive response to a **[MultiDrive Link Error] n d L F** is set with **[MultiDrive ErrorResp] n d L b** parameter.

Application functions and Device Role

Depending of the device role selected in case of Multipumps Architecture, some functions can become not configurable.

The following table shows the list of functions that can be activated depending of the **[M/P Device Role] n P d E** selection. When a function is described as not available, this function is not displayed on Display Terminal.

Function	[M/P Device Role] n P d E	
	[Master] n A S E or [Master Only] n A S E 1 or [Master or Slave] n A S E 2	[Slave] S L A V E
[Anti-jam monit] J A n -	Yes	Yes
[Priming pump ctrl] P P C -	Yes	Yes ⁽¹⁾
[Pipe fill] P F , -	Yes	Not available
[High flow monitoring] H F P -	Yes	Not available
[Flow limitation] F L n -	Yes	Not available
[Outlet pressure monitoring] o P P -	Yes	Not available
[Inlet pressure monitoring] , P P -	Yes	Not available
[PID controller] P , d -	Yes	Not available
[Sleep/Wakeup] S P w -	Yes	Not available
[Friction loss comp] F L C -	Yes	Not available
[Jockey pump] J K P -	Yes	Not available
[Feedback monitoring] F K n -	Yes	Not available

¹ Priming pump is used, when **[M/P Device Role] n P d E** is set to **[Slave] S L A V E**, only if the pump is controlled locally (for example during Anti-jam execution). In normal operation, the master manages the priming pump for the system.

[Pump System Archi] n P S A

Pump system architecture selection.

Setting	Code / Value	Description
[Mono-Pump]	n o	Multi-pump control deactivated Factory setting
[Single Drive]	V n d o L	Single drive with or without auxiliary pumps

Setting	Code / Value	Description
[Multi Drives]	<i>n V S d</i>	Multiple drives
[Multi Masters]	<i>n V S d r</i>	Multiple Drives with Master redundancy

[Nb Of Pumps] *Π P P n* ★

Number of pumps.

This parameter can be accessed if [Pump System Archi] *Π P S A* is set to [Single Drive] *V n d o L*.

Setting	Description
1...6	Setting range Factory setting: 1

[MultiDrive Config] $\Pi P V \mathcal{L} -$ Menu

Access

[Complete settings] → [Pump functions] → [Booster control] → [System architecture] → [Multidrive Config]

About This Menu

This menu can be accessed if [Pump System Archit] $\Pi P S A$ is set to [Multi Drives] $n V S d$ or [Multi Masters] $n V S d r$.

[M/P Device Role] $\Pi P d E \star$

Multipump master or slave selection

Setting	Code / Value	Description
[Slave]	$S L A V E$	Drive is managed by the Master drive of Multipump architecture Factory setting
[Master]	$\Pi A S E$	Drive manages the other drives of Multipump architecture NOTE: This selection can be accessed if [Pump System Archi] $\Pi P S A$ is set to [Multi Drives] $n V S d$.
[Master Only]	$\Pi A S E 1$	Drive is the primary master of the Multipump architecture with master redundancy. NOTE: This selection can be accessed if [Pump System Archi] $\Pi P S A$ is set to [Multi Masters] $n V S d r$.
[Master or Slave]	$\Pi A S E 2$	Drive acts as a slave as long as the drive with $\Pi A S E 1$ selection is available. It acts as master when the drive with $\Pi A S E 1$ selection is not available. NOTE: This selection can be accessed if [Pump System Archi] $\Pi P S A$ is set to [Multi Masters] $n V S d r$.

[Nb of Devices] $\Pi P G n \star$

Number of Multipump devices

This parameter can be accessed if [M/P Device Role] $\Pi P d E$ is set to [Master] $\Pi A S E$, [Master Only] $\Pi A S E 1$, or [Master or Slave] $\Pi A S E 2$

Setting	Description
1...6	Setting range Factory setting: 1

[M/P Device ID] $\Pi G i d \star$

Multipump device ID selection

The ID must be unique and selected between 1 and [Nb of Devices] $\Pi P G n$ on each drives of the MultiDrive Link group.

NOTE: This parameter is reset to [No] $n 0$ if one of the following parameter value is changed: [M/P Device Role] $\Pi P d E$, [Nb of Devices] $\Pi P G n$, [MDL Pairing Code] $\Pi d P \mathcal{L}$.

Setting	Description
[No] n o to 6	Setting range Factory setting: [No] n o

[MDL Pairing Code] n d P C ★

MultiDrive Link pairing code.

This parameter is used to manage several MultiDrive Link architectures on a same Ethernet network. The pairing code have to be the same on each drives of a MultiDrive Link architecture.

This parameter can be accessed if **[Access Level] L R C** is set to **[Expert] E P r**.

Setting	Description
0...255	Setting range Factory setting: 0

[Master Enable Assign] n P n E

Multi-pump master enable assignment.

This parameter can be accessed if **[M/P Device Role] n P d E** is set to **[Master or Slave] n R S E 2**.

This input is used to activate a drive of a MultiDrive Link group as a master.

Setting	Code / Value	Description
[Not Assigned]	n o	Not assigned Factory setting
[DI1]...[DI6]	L , I ... L , 6	Digital input DI1...DI6
[DI11]...[DI16]	L , I I ... L , 1 6	Digital input DI11...DI16 if VW3A3203 I/O extension module has been inserted
[CD00]... [CD10]	C d 0 0 ... C d 1 0	Virtual digital input CMD.0...CMD.10 in [I/O profile] , o configuration
[CD11]... [CD15]	C d 1 1 ... C d 1 5	Virtual digital input CMD.11...CMD.15 regardless of configuration
[C101]... [C110]	C 1 0 1 ... C 1 1 0	Virtual digital input CMD1.01...CMD1.10 with integrated Modbus Serial in [I/O profile] , o configuration
[C111]... [C115]	C 1 1 1 ... C 1 1 5	Virtual digital input CMD1.11...CMD1.15 with integrated Modbus Serial regardless of configuration
[C201]... [C210]	C 2 0 1 ... C 2 1 0	Virtual digital input CMD2.01...CMD2.10 with CANopen® fieldbus module in [I/O profile] , o configuration
[C211]... [C215]	C 2 1 1 ... C 2 1 5	Virtual digital input CMD2.11...CMD2.15 with CANopen® fieldbus module regardless of configuration
[C301]... [C310]	C 3 0 1 ... C 3 1 0	Virtual digital input CMD3.01...CMD3.10 with a fieldbus module in [I/O profile] , o configuration
[C311]... [C315]	C 3 1 1 ... C 3 1 5	Virtual digital input CMD3.11...CMD3.15 with a fieldbus module regardless of configuration
[C501]... [C510]	C 5 0 1 ... C 5 1 0	Virtual digital input CMD5.01...CMD5.10 with integrated Ethernet in [I/O profile] , o configuration
[C511]... [C515]	C 5 1 1 ... C 5 1 5	Virtual digital input CMD5.11...CMD5.15 with integrated Ethernet regardless of configuration

[Master Active Assign] P P P A

Multi-pump master activated assignment.

This parameter can be accessed if [M/P Device Role] P P d E is set to [Master Only] P A 5 E 1 or [Master or Slave] P A 5 E 2.

This output is used to indicate if the drive acts as a master.

Setting	Code / Value	Description
[No]	n o	Not assigned Factory setting
[R2]...[R3]	r 2...r 3	Relay output R2...R3
[R4]...[R6]	r 4...r 6	Relay output R4...R6 if VW3A3204 relay output option module has been inserted
[DQ11 Digital Output]... [DQ12 Digital Output]	d o 1 1... d o 1 2	Digital output DQ11...DQ12 if VW3A3203 I/O extension module has been inserted
[R61]...[R66]	r 6 1...r 6 6	Relay R61 ...R66 NOTE: This selection can be accessed on ATV660 and ATV680 equipped with Cabinet IO

[Master Act Delay] P P P d

Multi-pump master activation delay.

This parameter can be accessed if [M/P Device Role] P P d E is set to [Slave] 5 L A V E or [Master or Slave] P A 5 E 2.

This parameter allows to delay the master activation and acts also as a timer before triggering a [M/P Device Error] P P d F if no master is available.

Setting	Description
0.0...99.9 s	Setting range Factory setting: 0.0 s

[PwrOn Master Delay] P P P d

Multi-pump power-on master delay.

This parameter can be accessed if [M/P Device Role] P P d E is set to [Master Only] P A 5 E 1 or [Master or Slave] P A 5 E 2

Setting	Description
0...120 s	Setting range Factory setting: 30 s

[MultiDrive ErrorResp] P d L b

Response to Multi-Drive Link communication error.

Setting	Code / Value	Description
[Ignore]	n o	Detected error ignored
[Freewheel Stop]	y e 5	Freewheel stop

Setting	Code / Value	Description
[Per STT]	5 5 5	Stop according to [Type of stop] 5 5 5 parameter but without an error triggered after stop
[Ramp stop]	r 0 P	Stop on ramp Factory setting

[MDL Comm Timeout] 0 L 5 0

MultiDrive Link communication timeout.

Setting	Description
0.05...10.00 s	Setting range Factory setting: 0.25 s

[M/P Device ErrorResp] 0 P 0 0

Response to multipump device error.

Setting	Code / Value	Description
[Ignore]	0 0	Detected error ignored
[Freewheel Stop]	4 5 5	Freewheel stop
[Per STT]	5 5 5	Stop according to [Type of stop] 5 5 5 parameter but without an error triggered after stop
[Ramp stop]	r 0 P	Stop on ramp Factory setting

[Pumps configuration] *P ∩ P - Menu*

Access

[Complete settings] → [Pump functions] → [Booster control] → [System architecture] → [Pumps configuration]

Input and Output Configuration for Each Pump

For each pump (pump 1 in the example), it is possible to set:

- The drive digital output for the command: **[Pump 1 Cmd Assign]** *∩ P ∩ 1* if **[Lead Pump Alternation]** *∩ P L A* is not set to **[No]** *∩ ∅*.
- The drive digital input for the pump availability information: **[Pump 1 Ready Assign]** *∩ P , 1*. If not configured, the pump is considered as always available.

An internal configurable delay **[Pump Ready Delay]** *∩ P , d* is available. When the digital input assigned to **[Pump 1 Ready Assign]** *∩ P , 1* switches to the active state or after de-staging, the related pump is considered as not available during **[Pump Ready Delay]** *∩ P , d*.

This is used to wait that the auxiliary pumps are stopped and that all contactors between the drive and the motor (if existing) are closed before staging.

[Pump 1 Cmd Assign] *∩ P ∩ 1* ★

Command assignment for pump 1.

This parameter can be accessed if:

- **[Pump System Archi]** *∩ P S A* is set to **[Multi Drives]** *∩ V S d* or **[Multi Masters]** *∩ V S d r* or,
- **[Pump System Archi]** *∩ P S A* is set to **[Single Drive]** *V ∩ d ∅ L* and **[Nb Of Pumps]** *∩ P P n* is set to **[1]** *1* or above.

This parameter can be accessed if **[Nb Of Pumps]** *∩ P P n* is set to **[1]** *1* or above.

Setting	Code / Value	Description
[No]	<i>∩ ∅</i>	Not assigned Factory setting
[R2]...[R3]	<i>r 2...r 3</i>	Relay output R2...R3
[R4]...[R6]	<i>r 4...r 6</i>	Relay output R4...R6 if VW3A3204 relay output option module has been inserted
[DQ11 Digital Output]... [DQ12 Digital Output]	<i>d ∅ 1 1... d ∅ 1 2</i>	Digital output DQ11...DQ12 if VW3A3203 I/O extension module has been inserted
[R61]...[R66]	<i>r 6 1...r 6 6</i>	Relay R61 ...R66 NOTE: This selection can be accessed on ATV660 and ATV680 equipped with Cabinet IO

[Pump 1 Ready Assign] *∩ P , 1* ★

Pump 1 ready to operate assignment.

This parameter can be accessed if **[Nb Of Pumps]** *∩ P P n* is set to **[1]** *1* or above.

Setting	Code / Value	Description
[Not Assigned]	n o	Not assigned Factory setting
[DI1]...[DI6]	L 1 1...L 1 6	Digital input DI1...DI6
[DI11]...[DI16]	L 1 1 1... L 1 1 6	Digital input DI11...DI16 if VW3A3203 I/O extension module has been inserted
[CD00]... [CD10]	C d 0 0... C d 1 0	Virtual digital input CMD.0...CMD.10 in [I/O profile] , o configuration
[CD11]... [CD15]	C d 1 1... C d 1 5	Virtual digital input CMD.11...CMD.15 regardless of configuration
[C101]... [C110]	C 1 0 1... C 1 1 0	Virtual digital input CMD1.01...CMD1.10 with integrated Modbus Serial in [I/O profile] , o configuration
[C111]... [C115]	C 1 1 1... C 1 1 5	Virtual digital input CMD1.11...CMD1.15 with integrated Modbus Serial regardless of configuration
[C201]... [C210]	C 2 0 1... C 2 1 0	Virtual digital input CMD2.01...CMD2.10 with CANopen® fieldbus module in [I/O profile] , o configuration
[C211]... [C215]	C 2 1 1... C 2 1 5	Virtual digital input CMD2.11...CMD2.15 with CANopen® fieldbus module regardless of configuration
[C301]... [C310]	C 3 0 1... C 3 1 0	Virtual digital input CMD3.01...CMD3.10 with a fieldbus module in [I/O profile] , o configuration
[C311]... [C315]	C 3 1 1... C 3 1 5	Virtual digital input CMD3.11...CMD3.15 with a fieldbus module regardless of configuration
[C501]... [C510]	C 5 0 1... C 5 1 0	Virtual digital input CMD5.01...CMD5.10 with integrated Ethernet Modbus TCP in [I/O profile] , o configuration
[C511]... [C515]	C 5 1 1... C 5 1 5	Virtual digital input CMD5.11...CMD5.15 with integrated Ethernet Modbus TCP regardless of configuration
[DI1 (Low level)]...[DI6 (Low level)]	L 1 L ...L 6 L	Digital input DI1...DI6 used at low level

[Pump 2 Cmd Assign] n P o 2 ★

Command assignment for pump 2.

This parameter can be accessed if [Nb Of Pumps] n P P n is set to [2] 2 or above.

Identical to [Pump 1 Cmd Assign] n P o 1, page 261.

[Pump 2 Ready Assign] n P , 2 ★

Pump 2 ready to operate assignment.

This parameter can be accessed if [Nb Of Pumps] n P P n is set to [2] 2 or above.

Identical to [Pump 1 Ready Assign] n P , 1, page 261.

[Pump 3 Cmd Assign] n P o 3 ★

Command assignment for pump 3.

This parameter can be accessed if [Nb Of Pumps] n P P n is set to [3] 3 or above.

Identical to [Pump 1 Cmd Assign] n P o 1, page 261.

[Pump 3 Ready Assign] PP 3 ★

Pump 3 ready to operate assignment.

This parameter can be accessed if **[Nb Of Pumps]** PP P n is set to **[3]** 3 or above.

Identical to **[Pump 1 Ready Assign]** PP 1 , page 261.

[Pump 4 Cmd Assign] PP o 4 ★

Command assignment for pump 4.

This parameter can be accessed if **[Nb Of Pumps]** PP P n is set to **[4]** 4 or above.

Identical to **[Pump 1 Cmd Assign]** PP o 1 , page 261.

[Pump 4 Ready Assign] PP 4 ★

Pump 4 ready to operate assignment.

This parameter can be accessed if **[Nb Of Pumps]** PP P n is set to **[4]** 4 or above.

Identical to **[Pump 1 Ready Assign]** PP 1 , page 261.

[Pump 5 Cmd Assign] PP o 5 ★

Command assignment for pump 5.

This parameter can be accessed if **[Nb Of Pumps]** PP P n is set to **[5]** 5 or above.

Identical to **[Pump 1 Cmd Assign]** PP o 1 , page 261.

[Pump 5 Ready Assign] PP 5 ★

Pump 5 ready to operate assignment.

This parameter can be accessed if **[Nb Of Pumps]** PP P n is set to **[5]** 5 or above.

Identical to **[Pump 1 Ready Assign]** PP 1 , page 261.

[Pump 6 Cmd Assign] PP o 6 ★

Command assignment for pump 6.

This parameter can be accessed if **[Nb Of Pumps]** PP P n is set to **[6]** 6 or above.

Identical to **[Pump 1 Cmd Assign]** PP o 1 , page 261.

[Pump 6 Ready Assign] PP 6 ★

Pump 6 ready to operate assignment.

This parameter can be accessed if **[Nb Of Pumps]** PP P n is set to **[6]** 6 or above.

Identical to **[Pump 1 Ready Assign]** PP 1 , page 261.

[System Architecture] 1119 - Menu

Access

[Complete settings] → [Pump functions] → [Booster control] → [System architecture]

[Pump Cycling Mode] 1111

Pump cycling mode.

Setting	Code / Value	Description
[FIFO]	F , F o	First in first out
[LIFO]	L , F o	Last in first out
[Runtime]	r t , 1 E	Pump runtime Factory setting
[Runtime&LI-FO]	r t L F	Runtime and Last in first out NOTE: This choice is not available if [Pump System Archi] 1119 is set to [Multi Drives] n v 5 d or [Multi Masters] n v 5 d r .

[Lead Pump Alternation] 1118

Lead pump alternation.

This parameter can be accessed if [Pump System Archi] 1119 is set to [Single Drive] v n d o L .

NOTE: If [Lead Pump Alternation] 1118 is not set to [No] n o , the [Pump 1 Cmd Assign] 1111 and [Pump 1 Ready Assign] 1112 have to be configured.

Setting	Code / Value	Description
[No]	n o	Deactivated Factory setting
[Standard]	Y E 5	Standard alternation
[Redundancy]	r E d	Redundancy mode

[Pump Auto Cycling] 1113

Pump auto cycling.

This parameter can be accessed if [Pump System Architecture] 1119 is set to [Single Drive] v n d o L .

Setting	Description
0.0...24.0 h	Setting range Factory setting: 0.0 h

[Pump Ready Delay] 1114

Pump ready delay.

It corresponds to the stop time of the pumps. The pumps are considered as in running state and can not be staged during this delay, whatever the active command channel.

Setting	Description
0...3600 s	Setting range Factory setting: 0 s

[MultiPump ErrorResp] 5 5 5 5

Response to multipump error.

This parameter can be accessed if **[Pump System Archi] 5 5 5 5** is set to **[Single Drive] 5 5 5 5**

Setting	Code / Value	Description
[Ignore]	5 5	Detected error ignored
[Freewheel Stop]	5 5 5	Freewheel stop Factory setting
[Per STT]	5 5 5	Stop according to [Type of stop] 5 5 5 parameter but without an error triggered after stop
[Ramp stop]	5 5 5	Stop on ramp

[Booster control] 5 5 - Menu

Access

[Complete settings] → [Pump functions] → [Booster control] → [Booster control]

About This Menu

This menu is used to set the booster control parameters.

Multiple drives control

The multiple drives control mode is configured using [M/P Speed Mode] 5 5 . It has an effect on how the pump speed will be managed when running together. This parameter must be the same on all the drives of MultiPump architecture

Distributed Speed Control Mode

If [M/P Speed Mode] 5 5 is set to [Distributed] 5 5 , the pumps will be staged and destaged one by one. With this selection, the last staged pump runs at variable speed and other pumps run at fixed speed.

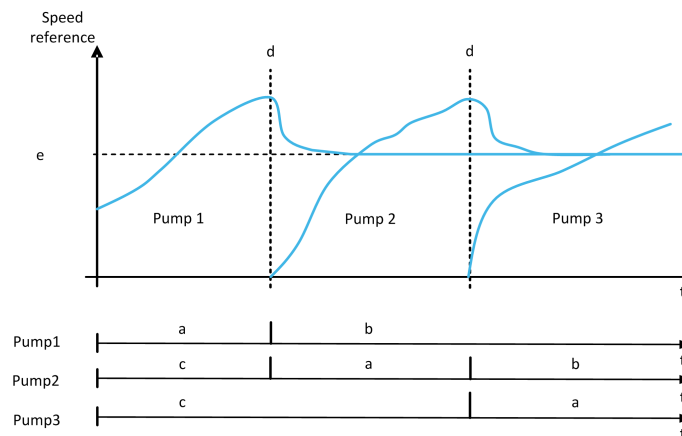

- a Pump runs at variable speed
- b Pump runs at fixed speed
- c Pump stopped
- d Pump staging
- e Fixed reference frequency in distributed mode: [Pump Fixed Freq] 5 5 5

Advanced Speed Control Mode

If [M/P Speed Mode] 5 5 is set to [Advanced] 5 5 , the pumps are staged and destaged one by one. With this selection, all pumps run at the same speed.

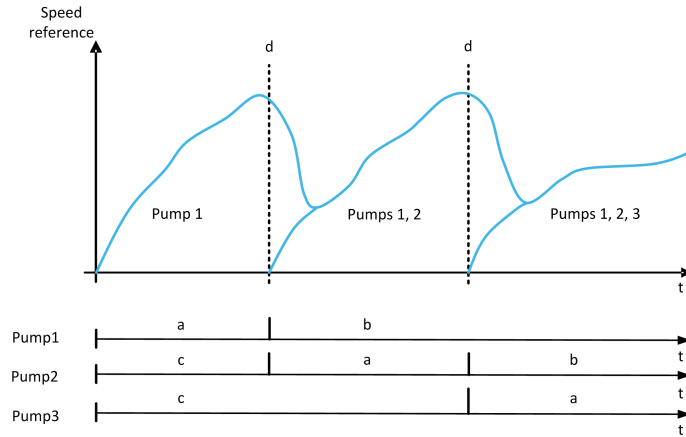

- a Pump runs at variable speed
- b Pump speed follows the last staged pump speed
- c Pump stopped
- d Pump staging

Synchronized Speed Control Mode

If [M/P Speed Mode] 1 P 5 5 is set to [Synchronized] 5 4 n 5, the pumps are staged and destaged simultaneously. With this selection, all pumps run at the same speed.

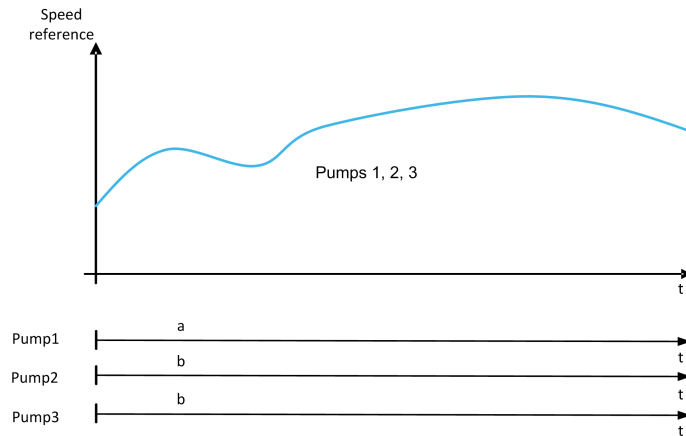

- a Pump runs at variable speed
- b Pump speed follows the pump 1 speed

[Booster Control] 5 5 1

Booster control activation.

Setting	Code / Value	Description
[No]	n o	Booster control function disabled Factory setting
[Yes]	5 5 5	Booster control function enabled

[Type of Control] 5 o 5 5

Type of control for the PID = unit choice.

This parameter can be accessed if:

- **[Pump System Archi] $\Pi P S R$** is set to **[Multi Drives] $n V S d r$** or **[Multi Masters] $n V S d r$** and,
- **[Booster Control] $b C \Pi$** is set to **[Yes] $Y E S$** .

Setting	Code / Value	Description
[nA]	$n A$	(without unit) Factory setting
[Pressure]	$P r E S S$	Pressure control and unit
[Flow]	$F L o W$	Flow control and unit
[Other]	$o t H E r$	Other control and unit (%)

[M/P Speed Mode] $\Pi P S E$

Multipump speed mode selection

This parameter can be accessed if:

- **[Pump System Archi] $\Pi P S R$** is set to **[Multi Drives] $n V S d r$** or **[Multi Masters] $n V S d r$** and,
- **[M/P Device Role] $\Pi P d E$** is set to **[Master] $\Pi R S E$** or **[Master Only] $\Pi R S E 1$** or **[Master or Slave] $\Pi R S E 2$** .

Setting	Code / Value	Description
[Distributed]	$d \Pi C$	Distributed multipump speed control mode
[Advanced]	$A \Pi C$	Advanced multipump speed control mode Factory setting
[Synchron-ized]	$S Y n C$	Synchronized multipump speed control mode

[Pump Fixed Freq] $\Pi P F S \star$

Pump fixed frequency in distributed mode

This parameter can be accessed if **[M/P Speed Mode] $\Pi P S E$** is set to **[Distributed] $d \Pi C$** .

Setting ()	Description
0.0...500.0 Hz	Setting range Factory setting: 50 Hz

[Booster Nb Of Pumps] $b C P n \star$

Booster number of pumps

Maximum number of pumps that can operate in the same time.

NOTE: If set to 0, there is no maximum defined. All the pumps of the architecture can be used.

This parameter can be accessed if:

- **[Booster Control] $b C \Pi$** is set to **[Yes] $Y E S$** and,
- **[M/P Speed Mode] $\Pi P S E$** is not set to **[Synchronized] $S Y n C$**

This parameter can be accessed if **[M/P Speed Mode]** $\mathcal{M} \mathcal{P} \mathcal{S} \mathcal{L}$ is set to **[Distributed]** $\mathcal{d} \mathcal{M} \mathcal{L}$ or **[Advanced]** $\mathcal{A} \mathcal{M} \mathcal{L}$.

Setting ()	Description
0...6	Setting range Factory setting: 0

[Stage/Destage condition] 5 5 5 - Menu

Access

[Complete settings] → [Pump functions] → [Booster control] → [Booster control] → [Stage/Destage condition]

About This Menu

It is necessary to specify how the stage and de-stage conditions are managed by setting the [Stage/Destage condition] 5 5 5 - menu:

- **[Speed] 5 P d**: staging/de-staging occurs according to conditions on the drive output frequency (Lead pump velocity).
- **[Feedback] F b K**: staging/de-staging occurs according to conditions on the outlet pressure feedback.
- **[Speed+Flow] 5 P F L**: staging occurs according to conditions on the drive output frequency (pump velocity), de-staging occurs according to flow conditions.
- **[Feedback+Flow] F b F L**: staging occurs according to conditions on the outlet pressure feedback, de-staging occurs according to flow conditions.
- **[Energy Optimized] o P E**: staging/de-staging occurs automatically to optimize the energy consumption of the system.

After a staging or de-staging condition is taken into account, no new staging or de-staging can occur during **[Booster S/D Interval] b 5 d E** delay. This is applied in any case, regardless of the settings of the function.

Staging/Destaging on Speed Condition

- Staging occurs if the reference frequency stays above **[Booster Stg Speed] b 5 5** for longer than **[Booster Stg Delay] b 5 d**.
- De-staging occurs if the reference frequency stays below **[Booster Dstg Speed] b d 5** for longer than **[Booster Dstg Delay] b d d**.

Staging/Destaging on Pressure Feedback Condition

- The working area **[Booster Working Range] b E W R** is expressed in a % of the reference value for the pressure.
- Staging occurs if PID error (taking into account **[PID Inversion] P , E**) stays below the working area while PID controller is at high limit speed for longer than **[Booster Stg Delay] b 5 d**.

High limit speed corresponds to limitation speed of PID (minimum between **[High Speed] H 5 P** & **[PID Max Output] P o H**).

- De-staging occurs if PID error (taking into account **[PID Inversion] P , E**) stays above working area while PID controller is at low limit speed, for longer than **[Booster Dstg Delay] b d d**.

Low limit speed corresponds to speed at which PID controller has no effect (maximum between **[Low Speed] L 5 P** & **[PID Min Output] P o L**).

Destaging on Flow Condition

- If **[Booster S/D Condition] b 5 d E** is set to **[Speed+Flow] 5 P F L**: staging occurs according to Speed condition (see Staging/Destaging on Speed Condition description).

- If **[Booster S/D Condition] b 5 d C** is set to **[Feedback+Flow] F b F L** : staging occurs according to Pressure Feedback condition (see Staging/ Destaging on Pressure Feedback Condition description).
- De-staging occurs according to flow level **[Booster Dstg Flow] b d F** . Flow sensor or estimated system flow needs to be configured.
- If the **[Booster Dstg Flow] b d F** level is not reached and if pump is running at its low speed, de-staging occurs.

Staging/Destaging on Energy Optimized

If **[Booster S/D Condition] b 5 d C** is set to **[Energy Optimized] o P E** , staging/ de-staging occurs automatically according to the pump characteristics to optimize the energy consumption of the system.

- This method can be selected if the pump curve characteristics are configured with **[Mode] P C n = [PHQ] P H q** .
- The flow sensor or estimated system flow needs to be configured.
- **[Booster S/D Flow Hyst] b 5 d H** can be used to avoid many stage/de-stage of pumps.
- **[Head Static Offset] H E o** and **[Head Dynamic Gain] H E G** needs to be configured to have a good estimation of the required head according to the pressure setpoint.
- **[Pump Op Point Filter] w P X F** can be used to filter the pump operating point.

Staging/Destaging on Override

The override area is used whatever the configuration of the system and the strategy used. If the pressure feedback is out of the **[Booster Override Range] b C o R** range, expressed in % of the reference value for the pressure, a staging/ de-staging is immediate. This increases the reactivity of the system in case of an important and rapid variation of the demand. It allows suppressing the staging/ de-staging delay.

[Boos S/D Condition] b 5 d C

Booster stage/de-stage condition.

NOTE: The stage/de-stage condition list depends of the setting of **[M/P Speed Mode] n P 5 E**

Setting	Code / Value	Description
[Speed]	S P d	Staging/De-staging on speed condition
[Feedback]	F b K	Staging/De-staging on pressure feedback condition Factory setting
[Speed+Flow]	S P F L	Staging on speed, de-staging on flow condition
[Feedback +Flow]	F b F L	Staging on pressure feedback, de-staging on flow condition
[Energy Optimized]	o P E	Staging/De-staging automatically for energy optimization

[Inst. Flow Assign.] F 5 I A ★

Installation flow sensor assignment.

This parameter can be accessed if:

- **[Booster Control] b C P** is set to **[Yes] Y E 5**
- **[Booster S/D Condition] b S d C** is set to **[Speed+Flow] S F P L**

Setting	Code / Value	Description
[Not Configured]	n o	Not assigned Factory setting
[AI1]...[AI3]	A , 1...A , 3	Analog input AI1...AI3
[AI4]...[AI5]	A , 4...A , 5	Analog input AI4...AI5 if VW3A3203 I/O extension module has been inserted
[AI Virtual 1]... [AI Virtual 3]	A , V 1... A , V 3	Virtual analogic input 1...3
[Di5 PulseInput Assign- ment]...[Di6 PulseInput Assignment]	P , 5...P , 6	Digital input DI5...DI6 used as pulse input
[Est. Pump Flow]	S L P F	Sensor less estimated flow
[Est. System Flow]	S L S F	Estimated system flow This selection is only possible if [Pump System Archit] P P S A is set to [Multi Drives] n V S d or [Multi Masters] n V S d r NOTE: To use this selection, all the pump characteristics of the system must be configured.
NOTE: For sensor configuration, refer to section [Sensors assignment] , page 200.		

[Booster Working Range] b C W R ★

Booster working area in % of the reference value for the pressure.

This parameter can be accessed if **[Booster S/D Condition] b S d C** is set to **[Feedback] F b K**.

Setting (C)	Description
1.0...100.0%	Setting range in % of the reference value for the pressure Factory setting: 2.0%

[Booster Stg Speed] b S S ★

Booster stage speed.

This parameter can be accessed if **[Booster S/D Condition] b S d C** is set to **[Speed] S P d**.

Setting (C)	Description
0.0...500.0 Hz	Setting range Factory setting: 50.0 Hz

[Booster Dstg Speed] b d S ★

Booster de-stage speed.

This parameter can be accessed if **[Booster S/D Condition] *b 5 d ℓ*** is set to **[Speed] *5 P d***.

Setting 	Description
0.0...500.0 Hz	Setting range Factory setting: 40.0 Hz

[Booster Dstg Flow] *b d F* ★

Booster destage flow.

This parameter can be accessed if **[Booster S/D Condition] *b 5 d ℓ*** is set to **[Speed+Flow] *5 P F L*** or **[Feedback+Flow] *F b F L***.

Setting 	Description
0.0...3276.7	Setting range Factory setting: 0.0

[Booster Stg Delay] *b 5 d*

Booster stage delay.

This parameter can be accessed if **[M/P Speed Mode] *π P 5 ℓ*** is not set to **[Synchronized] *5 Y n ℓ***.

Setting 	Description
0.0...999.9 s	Setting range Factory setting: 10.0 s

[Booster Dstg Delay] *b d d*

Booster de-stage delay.

This parameter can be accessed if **[M/P Speed Mode] *π P 5 ℓ*** is not set to **[Synchronized] *5 Y n ℓ***.

Setting 	Description
0.0...999.9 s	Setting range Factory setting: 10.0 s

[Booster Override Range] *b ℓ o R*

Booster override range.

This parameter can be accessed if **[M/P Speed Mode] *π P 5 ℓ*** is not set to **[Synchronized] *5 Y n ℓ***.

Setting 	Code / Value	Description
[No]	<i>n o</i>	Booster override range disabled Factory setting
0.1...100.0%		Setting range

[Booster S/D Flow Hyst] b 5 d H

Booster stage/destage flow hysteresis.

This parameter can be used to avoid many stage/de-stage of pumps.

This parameter can be accessed if **[Booster S/D Condition] b 5 d C** is set to **[Energy Optimized] o P E**.

Setting ()	Description
0.0...100.0%	Setting range. Percentage of nominal pump flow. Factory setting: 3.0%

[Head Static Offset] H E o ★

Head static offset.

This parameter can be accessed if **[Booster S/D Condition] b 5 d C** is set to **[Energy Optimized] o P E**.

This parameter must be configured to allow good estimation of head.

Setting ()	Description
-100.0...100.0%	Setting range Factory setting: 0.0%

[Head Dynamic Gain] H E G ★

Head dynamic gain.

This parameter can be accessed if **[Booster S/D Condition] b 5 d C** is set to **[Energy Optimized] o P E**.

This parameter must be configured to allow good estimation of head.

Setting ()	Description
-100.0...100.0%	Setting range Factory setting: 0.0%

[Stage/DeStage method] 5 5 5 5 - Menu

Access

[Complete settings] → [Pump functions] → [Booster control] → [Booster control] → [Stage/DeStage method]

About This Menu

The stage/de-stage method is set by [Booster S/D Control] 5 5 5 5 parameter:

- **[Speed] 5 5 5 5**: during stage/de-stage, PID controller is by-passed and a fixed reference frequency is applied.
- **[Feedback] 5 5 5**: outlet pressure remains regulated by the PID controller during stage/de-stage.
- **[Advanced] 5 5 5 5**: outlet pressure remains regulated by the PID controller during stage/de-stage and disturbances due to stage/de-stage are taken into account by the PID controller to reduce them.

NOTE: When [Pump System Archi] 5 5 5 5 is not set to [Simple Drive] 5 5 5 5, only [Feedback] 5 5 5 method is available.

Staging/DeStaging on Speed Control

When the staging is requested, after the delay [Booster Stg Ramp Delay] 5 5 5 5, the variable speed pump output frequency is reduced to reach [Booster Stg Bypass Spd] 5 5 5 5 according to [Booster Stg Bypass Time] 5 5 5 5.

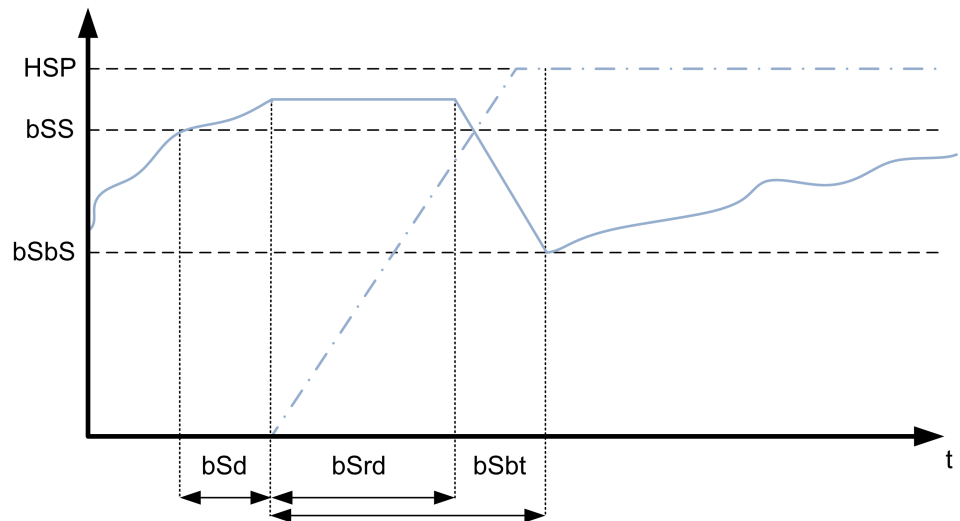

When the de-staging is requested, after the delay [Booster Dstg Ramp Delay] 5 5 5 5, the variable speed pump output frequency is increased to reach [Booster Dstg Bypass Spd] 5 5 5 5 according to [Booster Dstg Bypass Time] 5 5 5 5.

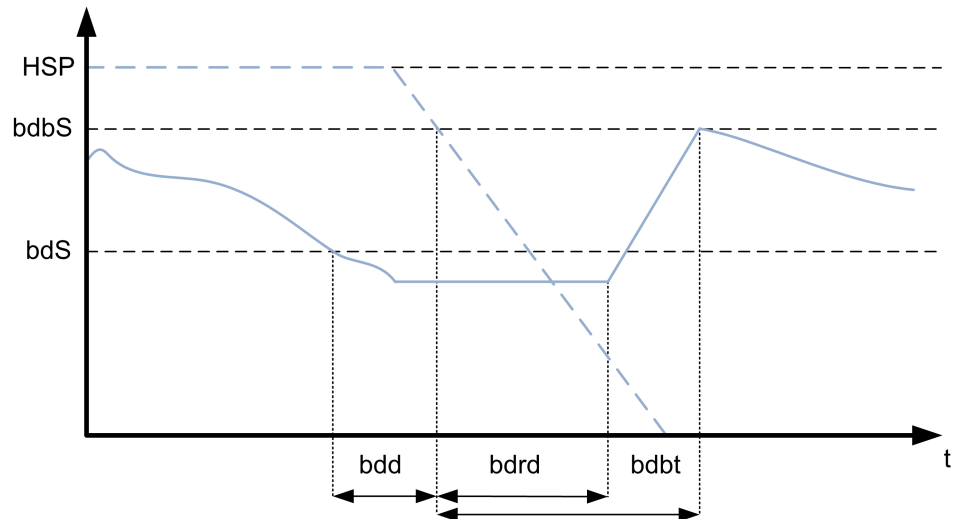

Staging/Destaging on Pressure Feedback Control

- When the staging is requested, a pump is started and the outlet pressure remains regulated according to the PID controller settings.
- When the de-staging is requested, a pump is stopped and the outlet pressure remains regulated according to the PID controller settings.

Staging/Destaging on Advanced Pressure Control

- When the staging is requested, a pump is started after the **[FeedFwd Stage Delay] FF 5 d** and the outlet pressure remains regulated according to the PID controller settings, in addition to a feedforward strategy to reduce the pressure overshoot.
- When the de-staging is requested, a pump is stopped after the **[FeedFwd Destage Delay] FF d d** and the outlet pressure remains regulated according to the PID controller settings, in addition to a feedforward strategy to reduce the pressure undershoot.
- The PID controller speed loop parameters should be adjusted to compensate the pressure variation linked to the normal operation of the system (close or open valves for example) without staging or de-staging a pump. The aim of the feedforward function is to reduce the overshoot or undershoot following a pump stage or de-stage. These two parameters should be set without variations generated by the system (close or open valves for example). The feedforward parameters should be adjusted after the PID controller is set.
- The **[FeedFwd Disturb Gain] FF G** parameter is a static gain that should be adjusted to reduce the maximum value of the output pressure overshoot or undershoot following a pump stage or de-stage.
- The **[FeedFwd Disturb Time] FF L G** parameter correspond to the time between the pump stage or de-stage command to the time when the maximum value of the output pressure overshoot or undershoot following a pump stage or de-stage is reached.

[Booster S/D Control] b 5 d n

Booster stage/de-stage control.

Setting	Code / Value	Description
[Speed]	<i>b S P d</i>	Basic speed
[Feedback]	<i>b F b K</i>	Basic feedback Factory setting
[Advanced]	<i>A d V l</i>	Advanced

[Booster Stg Bypass Speed] *b S b S* ★

Booster stage bypass speed.

This parameter can be accessed if **[Booster S/D Control]** *b S d n* is set to **[Speed]** *b S P d*.

Setting ()	Description
0.0...500.0 Hz	Setting range Factory setting: 45.0 Hz

[Booster Stg Bypass Time] *b S b t* ★

Booster stage bypass time.

This parameter can be accessed if **[Booster S/D Control]** *b S d n* is set to **[Speed]** *b S P d*.

Setting ()	Description
0.0...999.9 s	Setting range Factory setting: 3.0 s

[Booster Stg Ramp Delay] *b S r d* ★

Booster stage ramp delay.

This parameter can be accessed if **[Booster S/D Control]** *b S d n* is set to **[Speed]** *b S P d*.

Setting ()	Description
0.0...999.9 s	Setting range Factory setting: 1.0 s

[Booster Dstg Bypass Spd] *b d b S* ★

Booster de-stage bypass speed.

This parameter can be accessed if **[Booster S/D Control]** *b S d n* is set to **[Speed]** *b S P d*.

Setting ()	Description
0.0...500.0 Hz	Setting range Factory setting: 50.0 Hz

[Booster Dstg Bypass Time] b d b t ★

Booster de-stage bypass time.

This parameter can be accessed if **[Booster S/D Control] b 5 d n** is set to **[Speed] b 5 P d**.

Setting ()	Description
0.0...999.9 s	Setting range Factory setting: 1.0 s

[Booster Dstg Ramp Delay] b d r d ★

Booster de-stage ramp delay.

This parameter can be accessed if **[Booster S/D Control] b 5 d n** is set to **[Speed] b 5 P d**.

Setting ()	Description
0.0...999.9 s	Setting range Factory setting: 0.0 s

[FeedFwd Stage Delay] F F 5 d ★

Feed forward stage delay.

This parameter can be accessed if **[Booster S/D Control] b 5 d n** is set to **[Advanced] A d V C**.

Setting ()	Description
0.0...999.9 s	Setting range Factory setting: 1.0 s

[FeedFwd Destage Delay] F F d d ★

Feed forward de-stage delay.

This parameter can be accessed if **[Booster S/D Control] b 5 d n** is set to **[Advanced] A d V C**.

Setting ()	Description
0.0...999.9 s	Setting range Factory setting: 0.0 s

[FeedFwd Disturb Gain] F F G ★

Feed forward disturbance gain.

This parameter can be accessed if **[Booster S/D Control] b 5 d n** is set to **[Advanced] A d V C**.

Setting 	Description
0.0...100.0%	Setting range Factory setting: 20.0%

[FeedFwd Disturb Time] *FF ℄ ℄ ★*

Feed forward disturbance time.

This parameter can be accessed if **[Booster S/D Control]** *b 5 d ℄* is set to **[Advanced]** *A d V ℄*.

Setting 	Description
0.0...99.9 s	Setting range Factory setting: 3.0 s

[Booster control] *b 5 ℄ - Menu*

Access

[Complete settings] → **[Pump functions]** → **[Booster control]** → **[Booster control]**

[Booster S/D Interval] *b 5 d ℄*

Booster stage/de-stage time interval.

This parameter can be accessed if:

- **[Booster Control]** *b ℄ ℄* is set to **[Yes]** *Y E 5* and
- **[M/P Speed Mode]** *℄ P 5 ℄* is not set to **[Synchronized]** *5 Y ℄ ℄*

Setting 	Description
0.0...999.9 s	Setting range Factory setting: 15.0 s

[PID acceleration time] *ACC P ★*

PID: acceleration during start-up.

PID start ramp can be applied before starting the PID controller to allow reaching quickly the PID reference without increasing PID gains. If configured, the **[Start Accel Ramp]** *ACC 5* is applied up to **[Low Speed]** *L 5 P* instead of **[PID acceleration time]** *ACC P*.

This parameter can be accessed if **[PID feedback]** *P , F* is not set to **[Not Configured]** *℄ ℄*.

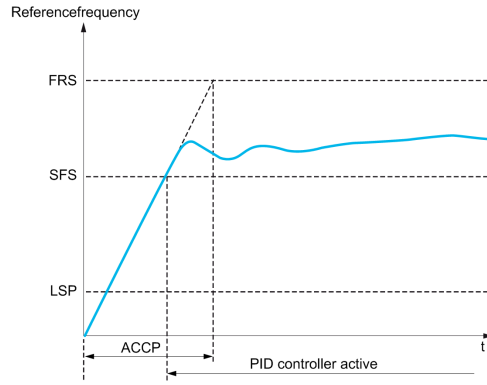

Setting (1)	Description
0.01...99,99 s (1)	Setting range Factory setting: 5.00 s
1 Range 0.01 to 99.99 s or 0.1 to 999.9 s or 1...6,000 s according to [Ramp increment] <i>inc.</i>	

[Pump functions] - [Level control]

Introduction

The aim of the level control function is to operate:

- Filling operation
- Emptying operation

This function offers a random level functionality by changing the start and stop level after each operation (at the end of filling or emptying operation) in order to start and stop the next filling or emptying operation from different levels.

The level control function can be used for single pump or multi-pump architecture.

This menu can be accessed if **[Application Selection] *R P P L*** is set to **[Pump Level Control] *L E V E L***.

[System architecture] *Π P 9* - Menu

Access

[Complete settings] → [Pump functions] → [Level control] → [System architecture]

About This Menu

Identical to **[System architecture] *Π P 9*** - Menu , page 244.

[Pumps configuration] $P \cup \cap P$ - Menu

Access

[Complete settings] → [Pump functions] → [Level control] → [System architecture] → [Pumps configuration]

About This Menu

Identical to [Pumps configuration] $P \cup \cap P$ - Menu , page 261.

[Level control] L C C - Menu

Access

[Complete settings] → [Pump functions] → [Level control] → [Level control]

About This Menu

The function activation is done by setting the [LevelCtrl Mode] L C M:

- **[No]** n o: the function is not activated.
- **[Filling]** F i L L: the function is activated to operate a filling operation.
- **[Emptying]** E m P t y: the function is activated to operate an emptying operation.

System Configuration

It is necessary to specify how the level of the liquid is acquired by setting the [LevelCtrl Sensor Type] L C n t:

- **[Level sensor]** L E v E L or **[Pressure sensor]** P r E S: the level information comes from an analog sensor. The value returned by each sensor (sensor 1 in the example) is compared continuously to the configured levels [Level 1 Pump Start] L r L I and [Level 1 Pump Stop] L P L I. It is necessary to associate an analog input for the level measurement by setting [Level Sensor Assign] L C S R.
- **[Level Switches]** S w: the level information comes from digital inputs. In this case. The state of each digital input indicates which pump to start and which pump to stop. The quantity of level switches required is equal to [Nb Of Pumps] n P P n. It is necessary to associate digital inputs (digital input 1 in the example) for the level measurement by setting [Level Switch1 Assign] L C W I.

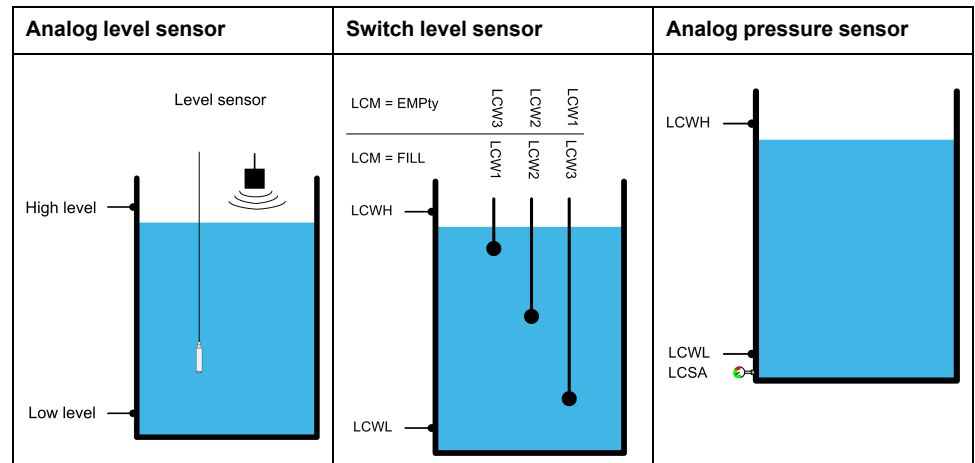

A random level factor [LevelCtrl Random Factor] L C r X can be set to reduce sedimentation in the tank. A value of 0% deactivates the function. The start level for the first pump to start and the stop level for the last pump to stop is applied taking into account a random offset based on +/- [LevelCtrl Random Factor] L C r X %.

Level Control Strategy

Three level control strategies are available through [LevelCtrl Strategy] L C S E parameter:

- If using an analog sensor (analog sensor level or pressure sensor), **[Standard] b A 5 , C** level control strategy and **[Energy Optimized] A d V** strategy are available.
- If using level switches, **[Switches] E r A d** strategy is available.

[Standard] b A 5 , C level control strategy

Starting and stopping pump is based on the comparison between the analog level sensor value and configured level values start and stop levels (Example for pump 1: the start level for the first pump to start **[Level 1st Pump Start] L r L 1** and the stop level for the last pump to stop **[Level 1st Pump Stop] L P L 1**) according to the number of used pumps in the system.

[Empty Tank Level] L C E J and **[Full Tank Level] L C E K** should be set to used this level control strategy.

The reference frequency follows a trajectory computed according to the level in tank.

The following figures show the principal of the basic strategy in the case of one pump for filling and emptying process:

Filling

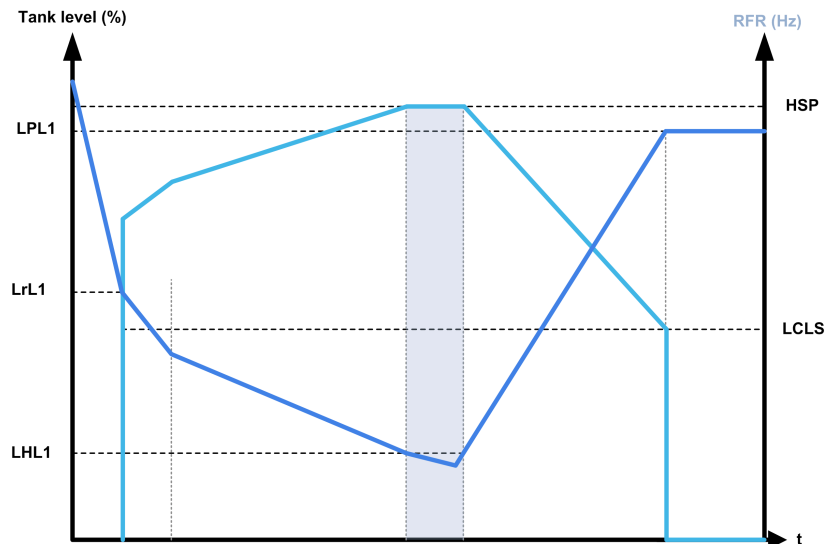

Emptying

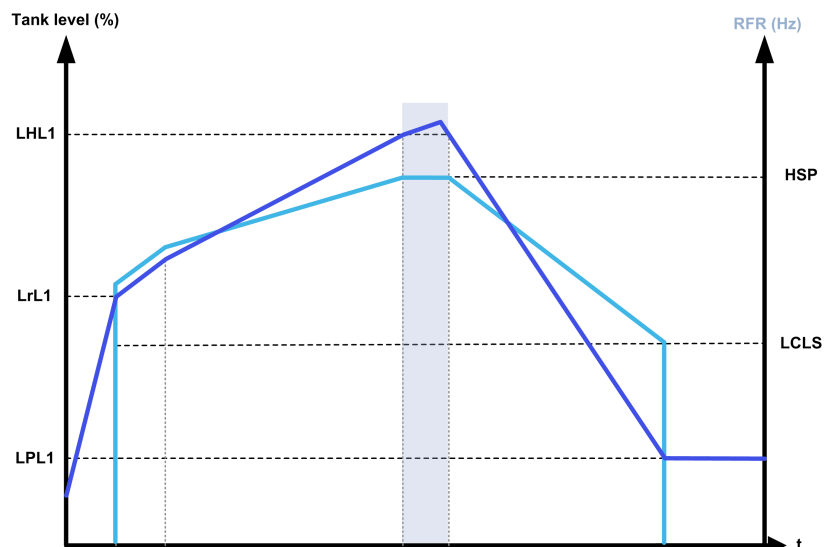

Strategy with one variable speed pump and fixed speed pumps

The following figures show how you can extrapolate this strategy in case of one variable speed pump and two fixed speed pumps:

Filling / three pumps

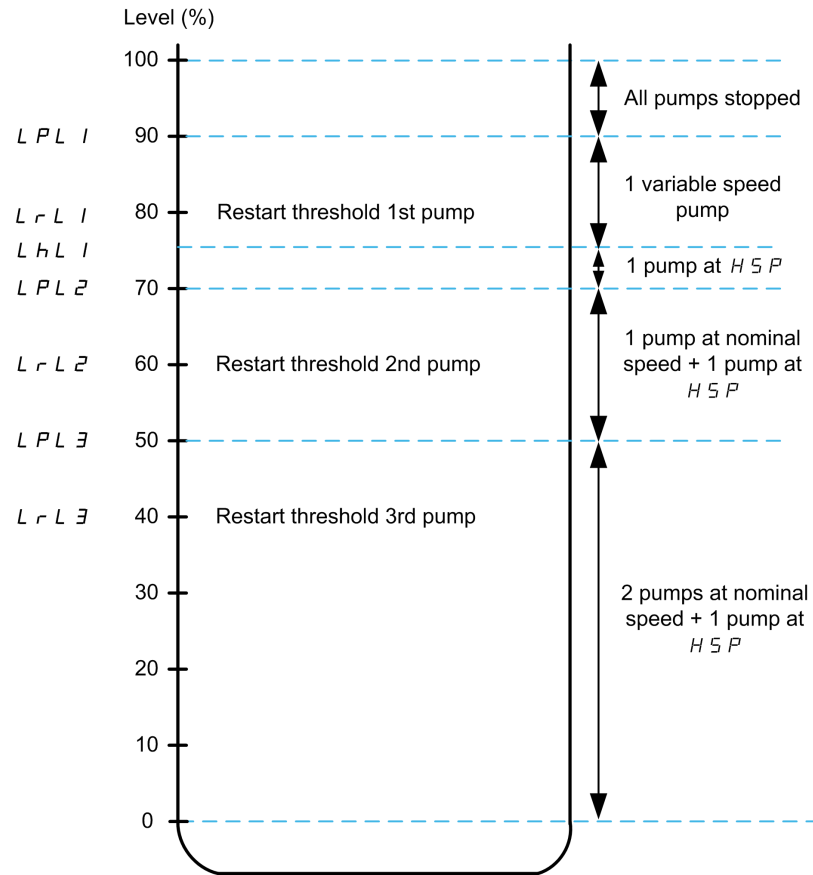

Emptying / three pumps

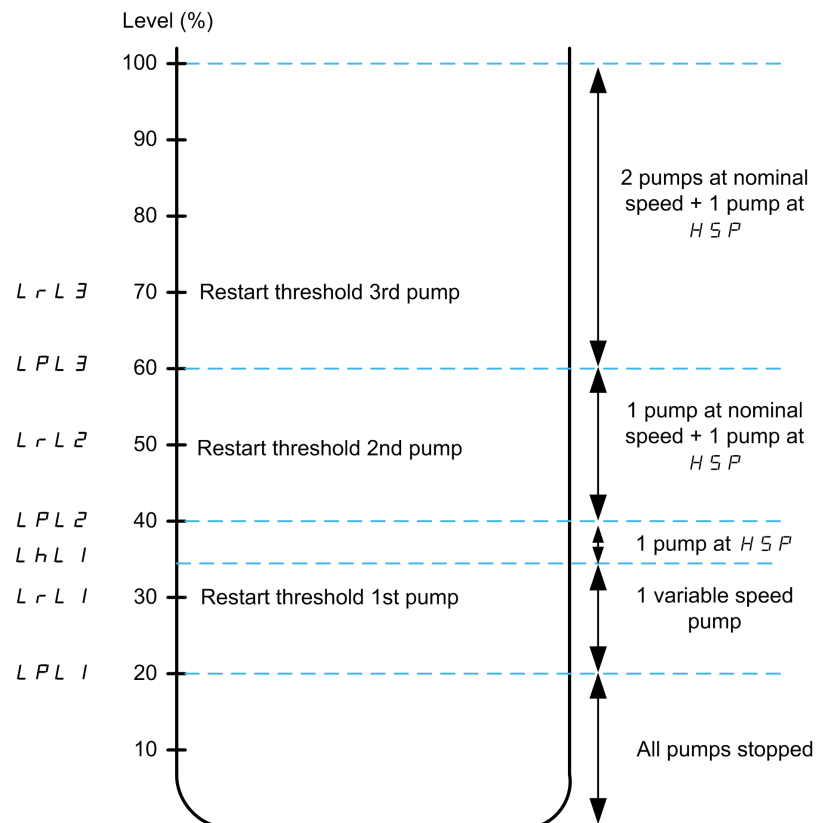

Cycle description example for emptying process with three pumps:

The variable speed pump starts at the first pump to start level **[Level 1st Pump Start] L r L 1**. If the level in the tank is still increasing, its frequency reference increases up to **[High Speed] H 5 P**. It corresponds to the tank level **[Level 1st Pump at HSP] L h L 1**.

When the level in the tank reaches the second pump to start **[Level 2nd Pump Start] L r L 2**, a fixed speed pump starts, the variable speed pumps is still at **[High Speed] H 5 P**.

When the level in the tank reaches the third pump to start level **[Level 3rd Pump Start] L r L 3**, the second fixed speed pump starts, the variable speed pumps is still at **[High Speed] H 5 P**.

When the level in the tank decreases under the first pump to stop level **[Level 1st Pump Stop] L P L 1**, a fixed speed pump stops, the variable speed pumps is still at **[High Speed] H 5 P**.

When the level in the tank decreases under second pump to stop level **[Level 2nd Pump Stop] L P L 2**, the second fixed speed pump stops, the variable speed pumps is still at **[High Speed] H 5 P**.

If the level in the tank is still decreasing, the frequency reference decreases up to **[LevelCtrl Low Speed] L C L 5**.

When the level in the tank decreases under the third pump to stop level **[Level 3rd Pump Stop] L P L 3**, the variable speed pump stops.

Strategy with multiple variable speed pumps

The following figures show how you can extrapolate this strategy in case of multiple variable speed pumps:

Filling / three pumps

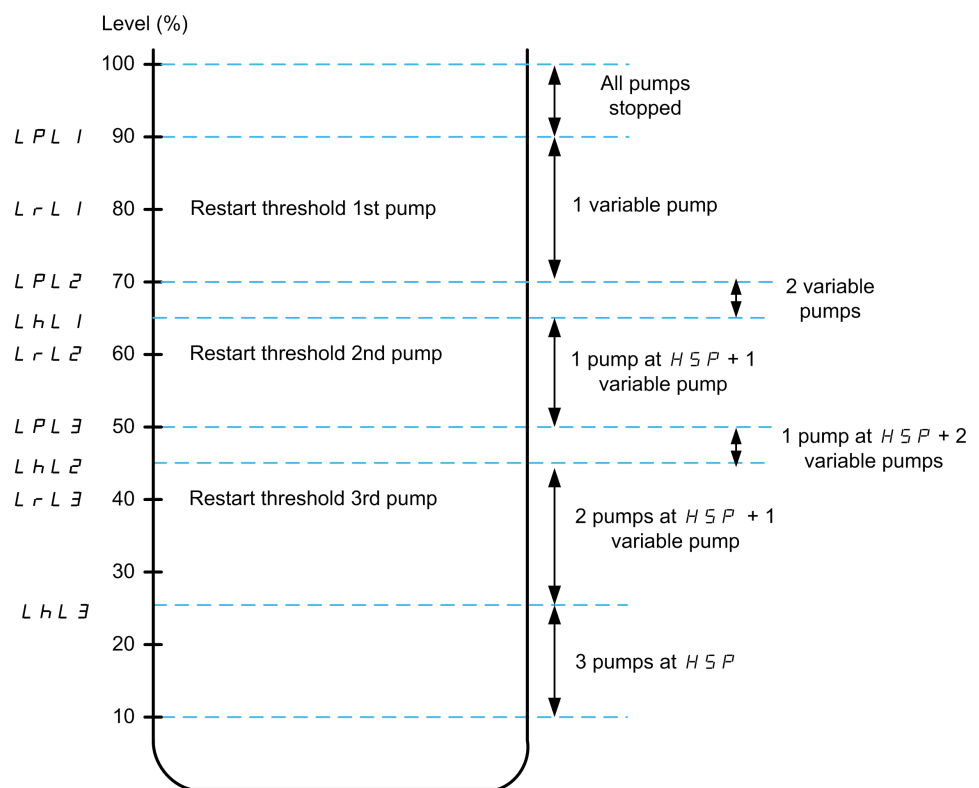

Emptying / three pumps

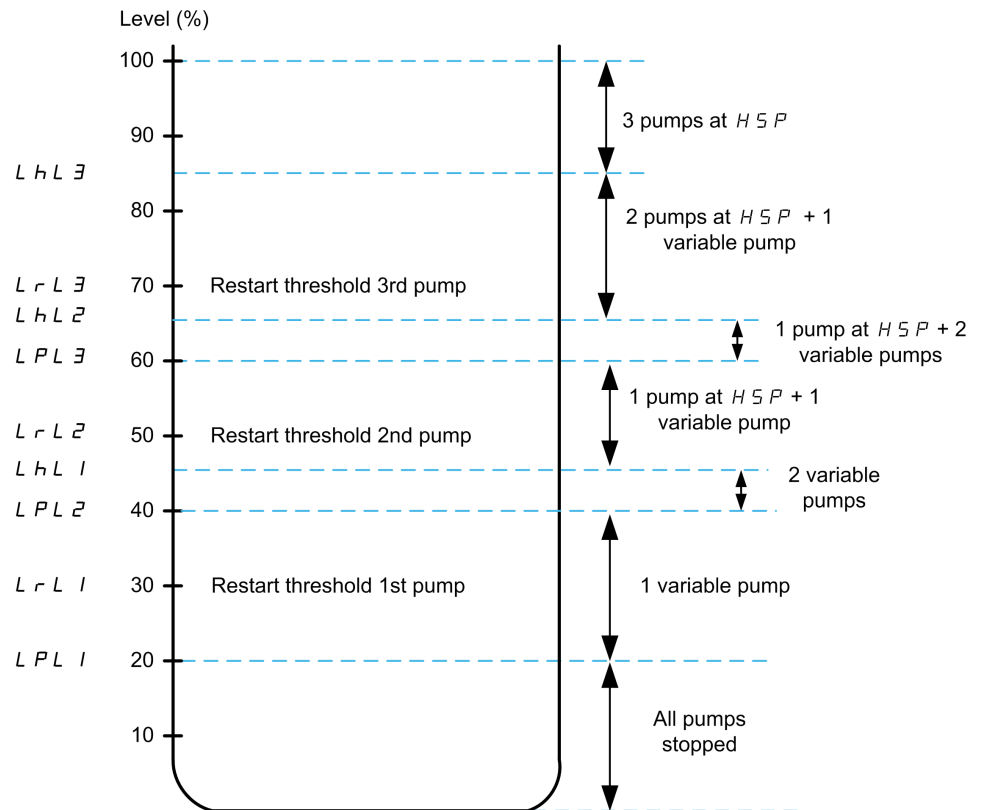

Cycle description example for emptying process with three pumps:

The first pump is started when level reaches the point **[Level 1st Pump Start]** L r L 1. The pump frequency reference is calculated by the system between the point **[Level 1st Pump Stop]** L P L 1 and **[Level 1st Pump at HSP]** L H L 1.

If the level in tank increases, the frequency reference increases until the **[High Speed]** H S P when level in tank reaches **[Level 1st Pump at HSP]** L H L 1 and remains at this frequency reference.

If the level in tank decreases, the frequency reference decreases until **[Low Speed]** L S P when the level in tank reaches **[Level 1st Pump Stop]** L P L 1 and then pump stops.

When the level in tank reaches the second pump to start **[Level 2nd Pump Start]** L r L 2, the second pump starts and the two pumps runs at same calculated frequency reference between **[Level 2nd Pump Stop]** L P L 2 and **[Level 2nd Pump at HSP]** L H L 2.

If the level in tank increases, the frequency reference of the two pumps increases until the **[High Speed]** H S P of each pump when level in tank reaches **[Level 2nd Pump at HSP]** L H L 2 and remains at this frequency reference.

If the level in tank decreases, the frequency reference decreases until a calculated low speed (point A of the curve) when the level in tank reaches **[Level 2st Pump Stop]** L P L 2 and then second pump stops.

When the level in tank reaches the third pump to start **[Level 3rd Pump Start]** L r L 3, the third pump starts and the three pumps runs at same calculated frequency reference between **[Level 3rd Pump Stop]** L P L 3 and **[Level 3rd Pump at HSP]** L H L 3. If the level in tank increases, the frequency reference of the three pumps increases until the **[High Speed]** H S P of each pump when level in tank reaches **[Level 3rd Pump at HSP]** L H L 3 and remains at this frequency reference.

If the level in tank decreases, the frequency reference decreases until a calculated low speed (point B of the curve) when the level in tank reaches **[Level 3rd Pump Stop]** L P L 3 and then third pump stops.

[Energy Optimized] R d V strategy

This strategy consists on the internal calculation of the optimal velocity profile which corresponds to the minimum of the energy consumed by the system during a filling or emptying process. The system runs at an optimal working point during the filling or emptying process.

To perform this strategy, following data are required:

- Validated pump curve characteristics (Hn, Pn, Qn at nominal speed). The pump curves should be configured previously in the **[Pump characteristics] P C r -** menu; pump parameterization is valid if the pump curve status **[Status] P C 5** equals to **[ACTIVE] R C E , V E**.
- Estimated or measured system flow.
- The volume of the tank **[Tank Volume] L C E u**, the minimum delivery height of the system **[Min Delivery Height] L C d J** and the maximum delivery height of the system **[Max Delivery Height] L C d K**.

[Switches] L r R d strategy

Starting and stopping pumps is based on level switches status (0: OFF or 1: ON).

- If **[Pump System Archi] P P 5 R** is set to **[Single Drive] u n d o L**, the variable speed pump runs at its nominal speed and auxiliary pumps runs at fixed speed.
- If **[Pump System Archi] P P 5 R** is set to **[Multi Drives] n V 5 d**, all pumps are running at their nominal speed.

The following figure shows the principal with the switches strategy (example with 3 pumps):

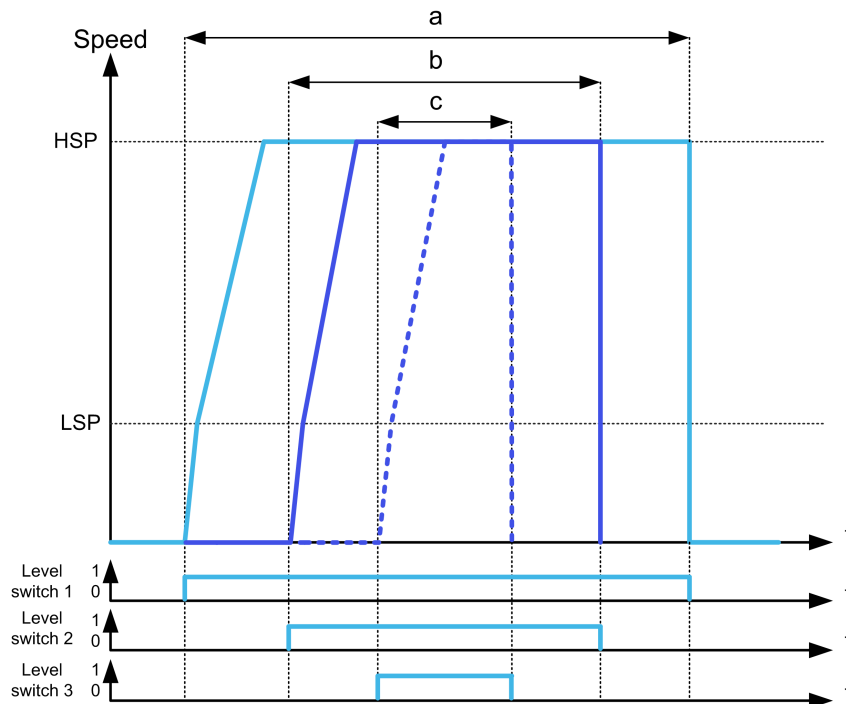

a Variable speed pump 1 (lead pump)

b Fixed or variable speed pump 2

c Fixed or variable speed pump 3

The previous example shows the way that the pumps are stopped if **[LevelCtrl Stop Mode] L C P n** is set to **[Individual Stop] i n d i u**. It is possible to stop all the pumps at the same time when level switch 1 changes to OFF state by setting **[LevelCtrl Stop Mode] L C P n** to **[Simultaneous Stop] C o n n**.

Warnings and Errors Handling

- A **[High Level Warning] L C H R** warning is active if the maximum level switch defined by **[Max Level Switch Assign] L C W L** is active.
If it occurs during filling process, a **[High Level Error] L C H F** error is activated.
This error is active also if the sensor value reaches 100% of the tank in filling mode and 0% in emptying mode.
- A **[Low Level Warning] L C L R** warning is active if the minimum level switch defined by **[Min Level Switch Assign] L C W H** is active.
If it occurs during emptying process, a **[Low Level Error] L C L F** error is activated.
- All pumps are stopped in case of **[High Level Error] L C H F** or **[Low Level Error] L C L F** error, whatever the setting of **[LevelCtrl Error Resp] L C F b**.
- A **[Level Switch Warning] L C W R** warning is active in case of an inconsistent feedback from the level switches (for example, if the level switches 1 and 3 are active and the level switch 2 is inactive).

[LevelCtrl Mode] L C P

Level control mode.

This parameter can be accessed if:

- **[Pump System Archi] P P S A** is set to **[Single Drive] V n d o L**, or
- **[Pump System Archi] P P S A** is set to **[Multi Drives] n V S d**, and **[M/P Device Role] P P d E** is set to **[Master] P A S E 1**, or
- **[Pump System Archi] P P S A** is set to **[Multi Masters] n V S d r** and,
- **[M/P Device Role] P P d E** is set to **[Master Only] P A S E 1** or **[Master or Slave] P A S E 2**.

Setting	Code / Value	Description
[No]	n o	Deactivated Factory setting
[Filling]	F , L L	Filling mode
[Emptying]	E P P E Y	Emptying mode

[LevelCtrl Nb Of Pumps] L C P n ★

Number of pumps used in Level Control

Maximum number of pumps that can operate in the same time

This parameter can be accessed if **[LevelCtrl Mode] L c P** is not set to **[No] n o**.

NOTE: If set to 0, there is no maximum defined. All the pumps of the architecture can be used.

Setting	Description
0...6	Setting range Factory setting: 0

[LevelCtrl Sensor Type] L C n E ★

Level control sensor type.

This parameter can be accessed if **[LevelCtrl Mode] L C n** is not set to **[No] n o**.

Setting	Code / Value	Description
[Level Switches]	<i>S W</i>	Level switches Factory setting
[Level Sensor]	<i>L E V E L</i>	Level sensor
[Pressure Sensor]	<i>P r E S</i>	Pressure sensor

[Level Sensor Assign] L C 5 A ★

Level sensor assignment.

This parameter can be accessed if:

- **[LevelCtrl Mode] L C n** is not set to **[No] n o**, and
- **[LevelCtrl Sensor Type] L C n E** is not set to **[Level Switches] S W**

This parameter can be accessed if **[Application Selection] R P P E** is set to **[Level] L E V E L**.

Setting	Code / Value	Description
[Not Configured]	<i>n o</i>	Not assigned Factory setting
[AI1]...[AI3]	<i>R , 1...R , 3</i>	Analog input AI1...AI3
[AI4]...[AI5]	<i>R , 4...R , 5</i>	Analog input AI4...AI5 if VW3A3203 I/O extension module has been inserted
[AI Virtual 1]... [AI Virtual 3]	<i>R , V 1... R , V 3</i>	Virtual analogic input 1...3
NOTE: For sensor configuration, refer to section [Sensors assignment] , page 200.		

[Level control] L C C - Menu

Access

[Complete settings] → [Pump functions] → [Level control] → [Level control]

About This Menu

This menu can be accessed if [Pump System Archi] P P S R is not set to [No] n o .

Delivery Height Configuration

To work at optimal System Best Efficiency Point, it is needed to configure the static head of the system by configuring [Min Delivery Height] L C d J and [Max Delivery Height] L C d K .

If these parameters are not configured, the system will work at Pump BEP instead of System BEP.

If only one of these parameters is configured, the other one will be calculated, taking into account the height estimation of the tank, based on sensor or tank configuration.

When the delivery height is constant whatever the tank level, the [Min Delivery Height] L C d J and [Max Delivery Height] L C d K must be configured.

The following figure describe how to calculate the delivery heights in case of a filling process from source tank pumped from top to destination tank filled from bottom:

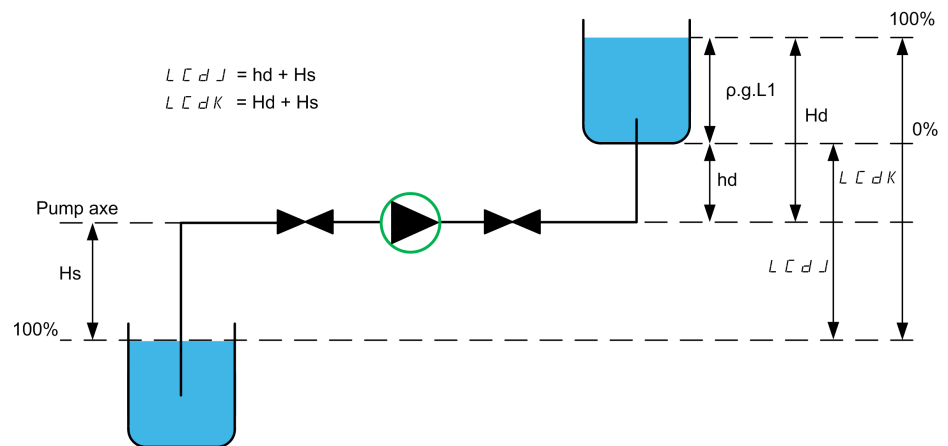

hd discharge height when destination tank is empty.

Hd discharge height when destination tank is full.

Hs suction height when source tank is full.

The following figure describe how to calculate the delivery heights in case of a filling process from source tank pumped from bottom to destination tank filled from bottom:

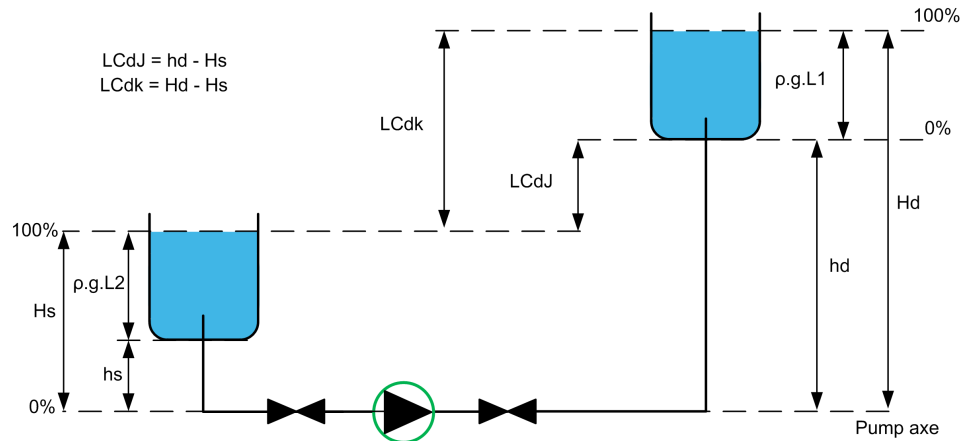

hd discharge height when destination tank is empty

Hd discharge height when destination tank is full.

hs suction height when source tank is empty.

Hs suction height when source tank is full.

The following figure describe how to calculate the delivery heights in case of a filling process from source tank pumped from top to destination tank filled from top:

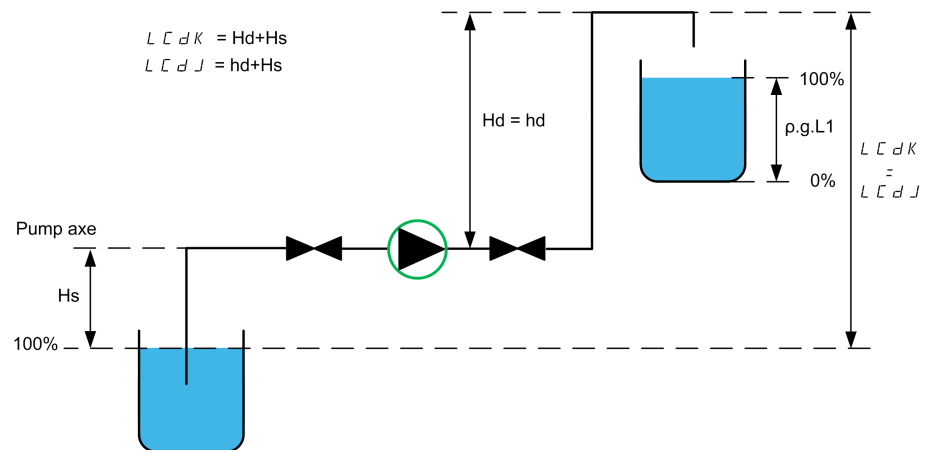

hd discharge height when destination tank is empty.

Hd discharge height when destination tank is full.

Hs suction height when source tank is full.

The following figure describes how to calculate the delivery heights in case of an emptying process:

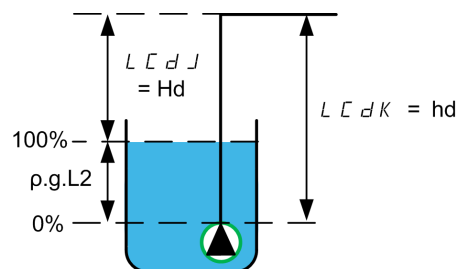

hd discharge height when destination tank is empty.

Hd discharge height when destination tank is full.

[Empty Tank Level] L C E J ★

Empty tank level sensor value.

This parameter can be accessed if [LevelCtrl Strategy] L c 5 E is not set to [Switches] E r R d.

Setting	Description
-32,767...32,767 m	Setting range in meter or in pressure value according to [LevelCtrl Sensor Type] L C n E Factory setting: 0.00 m

[Full Tank Level] L C E K ★

Full tank level sensor value.

This parameter can be accessed if [LevelCtrl Strategy] L c 5 E is not set to [Switches] E r R d.

Setting	Description
-32,767...32,767 m	Setting range in meter or in pressure value according to [LevelCtrl Sensor Type] L C n E Factory setting: 0.00 m

[LevelCtrl Strategy] L C 5 E ★

Level control strategy.

This parameter can be accessed if [LevelCtrl Mode] L c n is not set to [No] n o.

Setting	Code / Value	Description
[Switches]	E r R d	Switches Factory setting
[Standard]	b R S , c	Standard
[Energy Optimized]	R d V	Energy optimized Choosing this setting triggers a [Adv.Function Lock] R F L F error, contact your local Schneider representative

[Inst. Flow Assign.] F 5 I R ★

Installation flow sensor assignment.

This parameter can be accessed if [LevelCtrl Strategy] L c 5 E is set to [Energy Optimized] R d V.

Setting	Code / Value	Description
[Not Configured]	n o	Not assigned Factory setting
[AI1]...[AI3]	R , 1...R , 3	Analog input AI1...AI3
[AI4]...[AI5]	R , 4...R , 5	Analog input AI4...AI5 if VW3A3203 I/O extension module has been inserted
[AI Virtual 1]... [AI Virtual 3]	R , V 1... R , V 3	Virtual analogic input 1...3

Setting	Code / Value	Description
[Di5 PulseInput Assignment]...[Di6 PulseInput Assignment]	P , S ... P , E	Digital input DI5...DI6 used as pulse input
[Est. Pump Flow]	S L P F	Sensor less estimated flow
[Est. System Flow]	S L S F	Estimated system flow This selection is only possible if [Pump System Archit] P P S A is set to [Multi Drives] n V S d or [Multi Masters] n V S d r NOTE: To use this selection, all the pump characteristics of the system must be configured.
NOTE: For sensor configuration, refer to section [Sensors assignment] , page 200.		

[Tank Volume] L C E V ★

Tank volume to be filled or emptied.

This parameter can be accessed if [LevelCtrl Strategy] L c S E is set to [Energy Optimized] A d V .

Setting	Description
0...32,767	Setting range according to [Flow rate unit] S u F r Factory setting: 0

[Min Delivery Height] L C d J ★

Minimum delivery height.

This parameter can be accessed if [LevelCtrl Strategy] L c S E is set to [Energy Optimized] A d V .

Setting	Description
0.00...327.67 m	Setting range according to [Flow rate unit] S u F r Factory setting: 0.00 m

[Max Delivery Height] L C d K ★

Maximum delivery height

This parameter can be accessed if [LevelCtrl Strategy] L c S E is set to [Energy Optimized] A d V .

Setting	Description
[No] n o ...327.67 m	Setting range according to [Flow rate unit] S u F r Factory setting: [No] n o

[LevelCtrl Low Speed] L C L S ★

Level control low speed.

This parameter can be accessed if [LevelCtrl Strategy] L c 5 E is not set to [Switches] E r A d.

Setting ()	Description
0.0...500.0 Hz	Setting range Factory setting: 35.0 Hz

[LevelCtrl Stop Mode] L C P N ★

Level control stop mode.

This parameter can be accessed if [LevelCtrl Strategy] L c 5 E is set to [Switches] E r A d.

Setting	Code / Value	Description
[Simultaneous Stop]	c o n n	All pumps stopped simultaneously
[Individual Stop]	i n d i v	Each pump stopped individually Factory setting

[LevelCtrl Random Factor] L C r X ★

Level control random factor.

This parameter can be accessed if [LevelCtrl Mode] L c n is not set to [No] n o.

Setting ()	Description
0...100%	Setting range Factory setting: 0%

[Min Level Switch Assign] L C w L ★

Minimum level switch assignment.

This parameter can be accessed if [LevelCtrl Mode] L c n is not set to [No] n o.

Setting	Code / Value	Description
[Not Assigned]	n o	Not assigned Factory setting
[DI1]...[DI6]	L , 1...L , 6	Digital input DI1...DI6
[DI11]...[DI16]	L , 11... L , 16	Digital input DI11...DI16 if VW3A3203 I/O extension module has been inserted
[CD00]... [CD10]	C d 0 0... C d 1 0	Virtual digital input CMD.0...CMD.10 in [I/O profile] , o configuration
[CD11]... [CD15]	C d 1 1... C d 1 5	Virtual digital input CMD.11...CMD.15 regardless of configuration
[C101]... [C110]	C 1 0 1... C 1 1 0	Virtual digital input CMD1.01...CMD1.10 with integrated Modbus Serial in [I/O profile] , o configuration
[C111]... [C115]	C 1 1 1... C 1 1 5	Virtual digital input CMD1.11...CMD1.15 with integrated Modbus Serial regardless of configuration
[C201]... [C210]	C 2 0 1... C 2 1 0	Virtual digital input CMD2.01...CMD2.10 with CANopen® fieldbus module in [I/O profile] , o configuration

Setting	Code / Value	Description
[C211]... [C215]	L 2 1 1... L 2 1 5	Virtual digital input CMD2.11...CMD2.15 with CANopen® fieldbus module regardless of configuration
[C301]... [C310]	L 3 0 1... L 3 1 0	Virtual digital input CMD3.01...CMD3.10 with a fieldbus module in [I/O profile] , 0 configuration
[C311]... [C315]	L 3 1 1... L 3 1 5	Virtual digital input CMD3.11...CMD3.15 with a fieldbus module regardless of configuration
[C501]... [C510]	L 5 0 1... L 5 1 0	Virtual digital input CMD5.01...CMD5.10 with integrated Ethernet in [I/O profile] , 0 configuration
[C511]... [C515]	L 5 1 1... L 5 1 5	Virtual digital input CMD5.11...CMD5.15 with integrated Ethernet regardless of configuration

[Max Level Switch Assign] L L W h ★

Maximum level switch assignment.

This parameter can be accessed if [LevelCtrl Mode] L L 7 is not set to [No] n 0.

Setting	Code / Value	Description
[Not Assigned]	n 0	Not assigned Factory setting
[DI1]...[DI6]	L , 1...L , 6	Digital input DI1...DI6
[DI11]...[DI16]	L , 1 1... L , 1 6	Digital input DI11...DI16 if VW3A3203 I/O extension module has been inserted
[CD00]... [CD10]	L d 0 0... L d 1 0	Virtual digital input CMD.0...CMD.10 in [I/O profile] , 0 configuration
[CD11]... [CD15]	L d 1 1... L d 1 5	Virtual digital input CMD.11...CMD.15 regardless of configuration
[C101]... [C110]	L 1 0 1... L 1 1 0	Virtual digital input CMD1.01...CMD1.10 with integrated Modbus Serial in [I/O profile] , 0 configuration
[C111]... [C115]	L 1 1 1... L 1 1 5	Virtual digital input CMD1.11...CMD1.15 with integrated Modbus Serial regardless of configuration
[C201]... [C210]	L 2 0 1... L 2 1 0	Virtual digital input CMD2.01...CMD2.10 with CANopen® fieldbus module in [I/O profile] , 0 configuration
[C211]... [C215]	L 2 1 1... L 2 1 5	Virtual digital input CMD2.11...CMD2.15 with CANopen® fieldbus module regardless of configuration
[C301]... [C310]	L 3 0 1... L 3 1 0	Virtual digital input CMD3.01...CMD3.10 with a fieldbus module in [I/O profile] , 0 configuration
[C311]... [C315]	L 3 1 1... L 3 1 5	Virtual digital input CMD3.11...CMD3.15 with a fieldbus module regardless of configuration
[C501]... [C510]	L 5 0 1... L 5 1 0	Virtual digital input CMD5.01...CMD5.10 with integrated Ethernet in [I/O profile] , 0 configuration
[C511]... [C515]	L 5 1 1... L 5 1 5	Virtual digital input CMD5.11...CMD5.15 with integrated Ethernet regardless of configuration

[LevelCtrl Error Resp] L L F b ★

Level control error response.

This parameter can be accessed if [LevelCtrl Mode] L L 7 is not set to [No] n 0.

Setting	Code / Value	Description
[Ignore]	n o	Detected error ignored
[Freewheel Stop]	y E 5	Freewheel stop
[Per STT]	5 E E	Stop according to [Type of stop] 5 E E parameter but without an error triggered after stop
[Ramp stop]	r P P	Stop on ramp Factory setting

[Disturb Flow Comp] L C 9 G ★

Disturbance flow compensation.

This parameter can be accessed if [LevelCtrl Strategy] L C 5 E is set to [Energy Optimized] R d V .

Setting ()	Description
0...200%	Setting range Factory setting: 100%
NOTE: If the parameter is set below 100%, the priority is given to energy optimization compare to flow compensation.	

[Disturb Flow Resp Time] L C 9 E ★

Disturbance flow response time.

This parameter can be accessed if [LevelCtrl Strategy] L C 5 E is set to [Energy Optimized] R d V .

Setting ()	Description
0.0...10.00 s	Setting range Factory setting: 1.00 s

[LevelCtrl S/D Interval] L C d E ★

Level Control stage/destage interval

Time before taking into account a new stage/de-stage of pump.

This parameter can be accessed if [LevelCtrl Strategy] L C 5 E is set to [Energy Optimized] R d V .

Setting ()	Description
0.0...999.9 s	Setting range Factory setting: 15 s

[PI Integ Cst Time] L C E ,

Level Control: PI Integral Time

This parameter is accessible if **[LevelCtrl Mode] L C Π** is set to a value different than **[No] n o** and **[LevelCtrl Strategy] L c S E** is set to **[Energy Optimized] R d V**.

Setting	Description
0...99.99s	Setting range Factory setting: 5s

[PI Proportional Gain] L C K P

Level Control: PI Proportional Gain

This parameter is accessible if **[LevelCtrl Mode] L C Π** is set to a value different than **[No] n o** and **[LevelCtrl Strategy] L c S E** is set to **[Energy Optimized] R d V**.

Setting	Description
0...200%	Setting range Factory setting: 70%

[Vol Meas Filter Time] L C V F

Advanced Level Control: Volume Meas Filtering time

This parameter is accessible if **[Application Selection] R P P E** is set to **[Pump Level Control] L E V E L** and **[LevelCtrl Mode] L C Π** is set to a value different than **[No] n o**.

Setting	Description
0...99.99s	Setting range Factory setting: 10s

[Disturb Filter Time] L C Q F

Level Control: Disturbance Flow Filter Constante time

This parameter is accessible if **[LevelCtrl Mode] L C Π** is set to a value different than **[No] n o** and **[LevelCtrl Strategy] L c S E** is set to **[Energy Optimized] R d V**.

Setting	Description
0...99.99s	Setting range Factory setting: 10s

[Dist Lvl Sample Size] L C n b

Level Control: Number of points

This parameter is accessible if **[LevelCtrl Mode] L C Π** is set to a value different than **[No] n o** and **[LevelCtrl Strategy] L c S E** is set to **[Energy Optimized] R d V**.

Setting	Description
2...20	Setting range Factory setting: 10

[Sys Friction Loss Rate] L C L F

Level Control: Friction Losses Coefficient in Percentage.

This parameter is accessible if [LevelCtrl Mode] L C 7 is set to a value different than [No] 0 0 and [LevelCtrl Strategy] L C 5 E is set to [Energy Optimized] R D V .

Setting	Description
0...100%	Setting range Factory setting: 0%

[Flow Stabilization Thd] L C d F

Gap on installation Flow for stabilization check

This parameter is accessible if [LevelCtrl Mode] L C 7 is set to a value different than [No] 0 0 and [LevelCtrl Strategy] L C 5 E is set to [Energy Optimized] R D V .

Setting	Description
0...100%	Setting range Factory setting: 1%

[Level settings] L C L - Menu

Access

[Complete settings] → [Pump functions] → [Level control] → [Level settings]

About This Menu

According to the configured [LevelCtrl Strategy] L C L , it is necessary to assign:

- Digital inputs for the level switches, in case of [Switches] L r R d has been selected.
- Levels in % for the next pump to start, for next pump to stop, and for the pump at high speed, in case of [Standard] b R S , C or [Energy Optimized] R d V level control strategy has been selected.

[Level Switch1 Assign] L C W I ★

Level switch 1 assignment.

This parameter can be accessed if:

- [LevelCtrl Strategy] L C L is set to [Switches] L r R d , and
- [Nb Of Pumps] n P P n is higher than 0.

Setting	Code / Value	Description
[Not Assigned]	n o	Not assigned Factory setting
[DI1]...[DI6]	L , 1...L , 6	Digital input DI1...DI6
[DI11]...[DI16]	L , 11... L , 16	Digital input DI11...DI16 if VW3A3203 I/O extension module has been inserted
[CD00]... [CD10]	C d 0 0... C d 1 0	Virtual digital input CMD.0...CMD.10 in [I/O profile] , o configuration
[CD11]... [CD15]	C d 1 1... C d 1 5	Virtual digital input CMD.11...CMD.15 regardless of configuration
[C101]... [C110]	C 1 0 1... C 1 1 0	Virtual digital input CMD1.01...CMD1.10 with integrated Modbus Serial in [I/O profile] , o configuration
[C111]... [C115]	C 1 1 1... C 1 1 5	Virtual digital input CMD1.11...CMD1.15 with integrated Modbus Serial regardless of configuration
[C201]... [C210]	C 2 0 1... C 2 1 0	Virtual digital input CMD2.01...CMD2.10 with CANopen® fieldbus module in [I/O profile] , o configuration
[C211]... [C215]	C 2 1 1... C 2 1 5	Virtual digital input CMD2.11...CMD2.15 with CANopen® fieldbus module regardless of configuration
[C301]... [C310]	C 3 0 1... C 3 1 0	Virtual digital input CMD3.01...CMD3.10 with a fieldbus module in [I/O profile] , o configuration
[C311]... [C315]	C 3 1 1... C 3 1 5	Virtual digital input CMD3.11...CMD3.15 with a fieldbus module regardless of configuration
[C501]... [C510]	C 5 0 1... C 5 1 0	Virtual digital input CMD5.01...CMD5.10 with integrated Ethernet in [I/O profile] , o configuration
[C511]... [C515]	C 5 1 1... C 5 1 5	Virtual digital input CMD5.11...CMD5.15 with integrated Ethernet regardless of configuration

[Level Switch2 Assign] L c W 2 ★

Level switch 2 assignment.

This parameter can be accessed if:

- **[LevelCtrl Strategy] L C 5 E** is set to **[Switches] E r R d**, and
- **[Nb Of Pumps] Π P P n** is higher than 1.

Identical to **[Level Switch1 Assign] L c W 1**, page 300.

[Level Switch3 Assign] L c W 3 ★

Level switch 3 assignment.

This parameter can be accessed if:

- **[LevelCtrl Strategy] L C 5 E** is set to **[Switches] E r R d**, and
- **[Nb Of Pumps] Π P P n** is higher than 2.

Identical to **[Level Switch1 Assign] L c W 1**, page 300.

[Level Switch4 Assign] L c W 4 ★

Level switch 4 assignment.

This parameter can be accessed if:

- **[LevelCtrl Strategy] L C 5 E** is set to **[Switches] E r R d**, and
- **[Nb Of Pumps] Π P P n** is higher than 3.

Identical to **[Level Switch1 Assign] L c W 1**, page 300.

[Level Switch5 Assign] L c W 5 ★

Level switch 5 assignment.

This parameter can be accessed if:

- **[LevelCtrl Strategy] L C 5 E** is set to **[Switches] E r R d**, and
- **[Nb Of Pumps] Π P P n** is higher than 4.

Identical to **[Level Switch1 Assign] L c W 1**, page 300.

[Level Switch6 Assign] L c W 6 ★

Level switch 6 assignment.

This parameter can be accessed if:

- **[LevelCtrl Strategy] L C 5 E** is set to **[Switches] E r R d**, and
- **[Nb Of Pumps] Π P P n** is higher than 5.

Identical to **[Level Switch1 Assign] L c W 1**, page 300.

[Level 1st Pump Start] L r L 1 ★

Level to start first pump.

This parameter can be accessed if:

- **[LevelCtrl Strategy] L C 5 E** is not set to **[Switches] E r R d**, and
- **[Nb Of Pumps] Π P P n** is higher than 0.

Setting 	Description
0...100%	Setting range Factory setting: 0%

[Level 1st Pump Stop] *L P L I* ★

Level to stop first pump.

This parameter can be accessed if:

- **[LevelCtrl Strategy] *L C S E*** is not set to **[Switches] *E r A d***, and
- **[Nb Of Pumps] *Π P P n*** is higher than 0.

Setting 	Description
0...100%	Setting range Factory setting: 0%

[Level 1st Pump at HSP] *L h L I* ★

Level to reach first pump high speed.

This parameter can be accessed if:

- **[LevelCtrl Strategy] *L C S E*** is not set to **[Switches] *E r A d***, and
- **[Nb Of Pumps] *Π P P n*** is higher than 0.

Setting 	Description
0...100%	Setting range Factory setting: 0%

[Level 2nd Pump Start] *L r L 2* ★

Level to start second pump.

This parameter can be accessed if:

- **[LevelCtrl Strategy] *L C S E*** is not set to **[Switches] *E r A d*** or **[Energy Optimized] *A d V***, and
- **[Nb Of Pumps] *Π P P n*** is higher than 1.

Identical to **[Level 1st Pump Start] *L r L I***, page 301.

[Level 2nd Pump Stop] *L P L 2* ★

Level to stop second pump.

This parameter can be accessed if:

- **[LevelCtrl Strategy] *L C S E*** is not set to **[Switches] *E r A d*** or **[Energy Optimized] *A d V***, and
- **[Nb Of Pumps] *Π P P n*** is higher than 1.

Identical to **[Level 1st Pump Start] *L r L I***, page 302.

[Level 2nd Pump at HSP] L H L 2 ★

Level to reach second pump high speed.

This parameter can be accessed if:

- **[LevelCtrl Strategy] L C 5 E** is not set to **[Switches] E r R d** or **[Energy Optimized] R d V**, and
- **[Nb Of Pumps] P P P n** is higher than 1.

Identical to **[Level 1st Pump Start] L r L 1**, page 302.

[Level 3rd Pump Start] L r L 3 ★

Level to start third pump.

This parameter can be accessed if:

- **[LevelCtrl Strategy] L C 5 E** is not set to **[Switches] E r R d** or **[Energy Optimized] R d V**, and
- **[Nb Of Pumps] P P P n** is higher than 2.

Identical to **[Level 1st Pump Start] L r L 1**, page 301.

[Level 3rd Pump Stop] L P L 3 ★

Level to stop third pump.

This parameter can be accessed if:

- **[LevelCtrl Strategy] L C 5 E** is not set to **[Switches] E r R d** or **[Energy Optimized] R d V**, and
- **[Nb Of Pumps] P P P n** is higher than 2.

Identical to **[Level 1st Pump Start] L r L 1**, page 302.

[Level 3rd Pump at HSP] L H L 3 ★

Level to reach third pump high speed.

This parameter can be accessed if:

- **[LevelCtrl Strategy] L C 5 E** is not set to **[Switches] E r R d** or **[Energy Optimized] R d V**, and
- **[Nb Of Pumps] P P P n** is higher than 2.

Identical to **[Level 1st Pump Start] L r L 1**, page 302.

[Level 4th Pump Start] L r L 4 ★

Level to start fourth pump.

This parameter can be accessed if:

- **[LevelCtrl Strategy] L C 5 E** is not set to **[Switches] E r R d** or **[Energy Optimized] R d V**, and
- **[Nb Of Pumps] P P P n** is higher than 3.

Identical to **[Level 1st Pump Start] L r L 1**, page 301.

[Level 4th Pump Stop] L P L 4 ★

Level to stop fourth pump.

This parameter can be accessed if:

- **[LevelCtrl Strategy] L C 5 E** is not set to **[Switches] E r A d** or **[Energy Optimized] A d V**, and
- **[Nb Of Pumps] P P P n** is higher than 3.

Identical to **[Level 1st Pump Start] L r L 1**, page 302.

[Level 4th Pump at HSP] L h L 4 ★

Level to reach fourth pump high speed.

This parameter can be accessed if:

- **[LevelCtrl Strategy] L C 5 E** is not set to **[Switches] E r A d** or **[Energy Optimized] A d V**, and
- **[Nb Of Pumps] P P P n** is higher than 3.

Identical to **[Level 1st Pump Start] L r L 1**, page 302.

[Level 5th Pump Start] L r L 5 ★

Level to start fifth pump.

This parameter can be accessed if:

- **[LevelCtrl Strategy] L C 5 E** is not set to **[Switches] E r A d** or **[Energy Optimized] A d V**, and
- **[Nb Of Pumps] P P P n** is higher than 4.

Identical to **[Level 1st Pump Start] L r L 1**, page 301.

[Level 5th Pump Stop] L P L 5 ★

Level to stop fifth pump.

This parameter can be accessed if:

- **[LevelCtrl Strategy] L C 5 E** is not set to **[Switches] E r A d** or **[Energy Optimized] A d V**, and
- **[Nb Of Pumps] P P P n** is higher than 4.

Identical to **[Level 1st Pump Start] L r L 1**, page 302.

[Level 5th Pump at HSP] L h L 5 ★

Level to reach fifth pump high speed.

This parameter can be accessed if:

- **[LevelCtrl Strategy] L C 5 E** is not set to **[Switches] E r A d** or **[Energy Optimized] A d V**, and
- **[Nb Of Pumps] P P P n** is higher than 4.

Identical to **[Level 1st Pump Start] L r L 1**, page 302.

[Level 6th Pump Start] L r L 6 ★

Level to start sixth pump.

This parameter can be accessed if:

- **[LevelCtrl Strategy] L C 5 E** is not set to **[Switches] E r A d** or **[Energy Optimized] A d V**, and
- **[Nb Of Pumps] P P P n** is higher than 5.

Identical to **[Level 1st Pump Start] L r L 1**, page 301.

[Level 6th Pump Stop] L P L E ★

Level to stop sixth pump.

This parameter can be accessed if:

- **[LevelCtrl Strategy] L C 5 E** is not set to **[Switches] E r R d** or **[Energy Optimized] R d V**, and
- **[Nb Of Pumps] P P P n** is higher than 5.

Identical to **[Level 1st Pump Start] L r L I**, page 302.

[Level 6th Pump at HSP] L h L E ★

Level to reach sixth pump high speed.

This parameter can be accessed if:

- **[LevelCtrl Strategy] L C 5 E** is not set to **[Switches] E r R d** or **[Energy Optimized] R d V**, and
- **[Nb Of Pumps] P P P n** is higher than 5.

Identical to **[Level 1st Pump Start] L r L I**, page 302.

[Pump functions] - [PID controller]

[PID controller] P, d - Overview

About This Menu

NOTE: This function cannot be used with some other functions.

Block Diagram

The function is activated by assigning an analog input to the PID feedback (measurement).

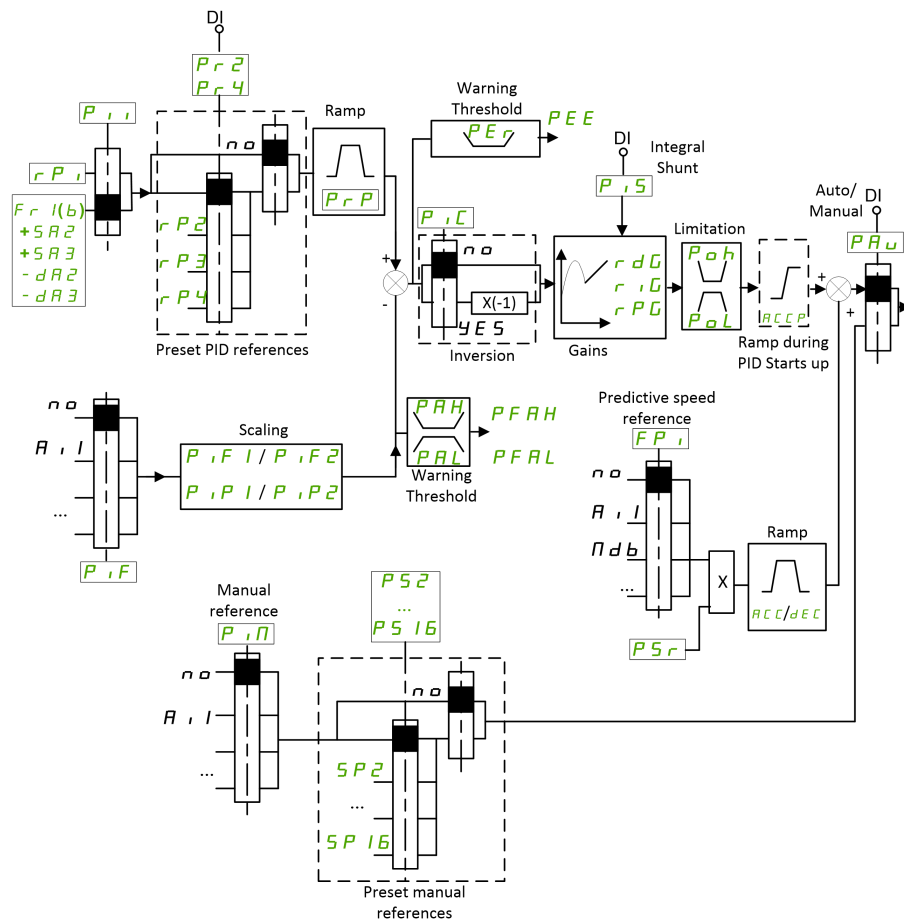

The PID feedback needs to be assigned to one of the analog inputs AI1 to AI5 or a pulse input, according to whether any I/O extension module has been inserted.

The PID reference needs to be assigned to the following parameters:

- Preset references via digital inputs ([Ref PID Preset 2] Pr2, [Ref PID Preset 3] Pr3, [Ref PID Preset 4] Pr4).
- In accordance with the configuration of [Intern PID Ref] Pi:
 - [Internal PID ref] Pi, or
 - Reference A [Ref Freq 1 Config] Fr1 or [Ref.1B channel] Fr1b.

Combination Table for Preset PID References:

DI (Pr 4)	DI (Pr 2)	Pr 2 = no	Reference
			r P 1, or F r I (b)
0	0		r P 1, or F r I (b)
0	1		r P 2
1	0		r P 3
1	1		r P 4

A predictive speed reference can be used to initialize the speed on restarting the process.

Scaling of feedback and references:

- **[Min PID feedback] P , F 1, [Max PID feedback] P , F 2** parameters can be used to scale the PID feedback (sensor range). This scale must be maintained for all other parameters.
- **[Min PID Process] P , P 1, [Max PID Process] P , P 2** parameters can be used to scale the adjustment range, for example the reference. **Check that the adjustment range remains within the sensor range.**

The maximum value of the scaling parameters is 32,767. To facilitate the installation, it is recommended to use values as close as possible to this maximum level, while retaining powers of 10 in relation to the actual values. The scaling is without unit if **[Type of control] E o C E** is set to **[NA] n A**, in % if set to **[OTHER] o E H E r**, in process unit if set to **[PRESSURE] P r E S S** or **[FLOW] F L o W**.

Example

Adjustment of the volume in a tank, 6...15 m³.

- Probe used 4-20 mA, 4.5 m³ for 4 mA and 20 m³ for 20 mA, with the result that **P , F 1 = 4,500** and **P , F 2 = 20,000**.
- Adjustment range 6 to 15 m³, with the result that **P , P 1 = 6,000** (min. reference) and **P , P 2 = 15,000** (max. reference).
- Example references:
 - r P 1 (internal reference) = 9,500
 - r P 2 (preset reference) = 6,500
 - r P 3 (preset reference) = 8,000
 - r P 4 (preset reference) = 11,200

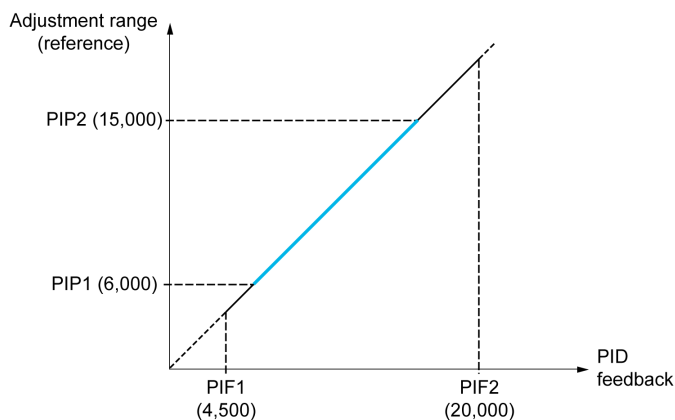

Other parameters:

- Reversal of the direction of correction **[PID Inversion] P , C** . If **[PID Inversion] P , C** is set to **[No] n o** , the speed of the motor increases when the detected error is positive (for example pressure control with a compressor). If **[PID Inversion] P , C** is set to **[Yes] y e s** , the speed of the motor decreases when the detected error is positive (for example temperature control using a cooling fan).
- The integral gain may be short-circuited by a digital input.
- A warning on the **[PID feedback Assign] P , F** may be configured.
- A warning on the **[PID error] r P E** may be configured.

"Manual - Automatic" Operation with PID

This function combines the PID controller, the preset speeds, and a manual reference. Depending on the state of the digital input, the speed reference is given by the preset speeds or by a manual reference input via the PID function.

Manual PID reference **[Manual PID reference] P , n**:

- Analog inputs AI1 to AI5
- Pulse inputs

Predictive speed reference **[Predictive Speed Ref] F P , :**

- **[AI1] R , 1**: analog input
- **[AI2] R , 2**: analog input
- **[AI3] R , 3**: analog input
- **[AI4] R , 4**: analog input if VW3A3203 I/O extension module has been inserted
- **[AI5] R , 5**: analog input if VW3A3203 I/O extension module has been inserted
- **[DI5 PulseInput Assignment] P , 5**: pulse input
- **[DI6 PulseInput Assignment] P , 6**: pulse input
- **[Ref.Freq-Rmt.Term] L C C**: Graphic Display Terminal
- **[Modbus] n d b**: integrated Modbus
- **[CANopen] C R n**: CANopen® (if inserted)
- **[Com. Module] n E E**: fieldbus option module (if inserted)
- **[Embedded Ethernet] E E H**: integrated Ethernet

Setting Up the PID Controller

1. Configuration in PID mode.

Refer to the Block Diagram, page 306.

2. Perform a test in factory settings mode.

To optimize the drive, adjust **[PID Prop.Gain] r P G** or **[PID Intgl.Gain] r , G** gradually and independently, and observe the effect on the PID feedback in relation to the reference.

3. If the factory settings are unstable or the reference is incorrect.

Step	Action
1	Perform a test with a speed reference in Manual mode (without PID controller) and with the drive on load for the speed range of the system: <ul style="list-style-type: none"> In steady state, the speed must be stable and comply with the reference, and the PID feedback signal must be stable. In transient state, the speed must follow the ramp and stabilize quickly, and the PID feedback must follow the speed. If not, see the settings for the drive and/or sensor signal and wiring.
2	Switch to PID mode.
3	Set [PID ramp] PrP to the minimum permitted by the mechanism without triggering an [DC Bus Overvoltage] obF .
4	Set the integral gain [PID Intgl.Gain] rIG to minimum.
5	Leave the derivative gain [PID derivative gain] rdG at 0.
6	Observe the PID feedback and the reference.
7	Switch the drive ON/OFF a number of times or vary the load or reference rapidly a number of times.
8	Set the proportional gain [PID Prop.Gain] rPG in order to ascertain the compromise between response time and stability in transient phases (slight overshoot and 1 to 2 oscillations before stabilizing).
9	If the reference varies from the preset value in steady state, gradually increase the integral gain [PID Intgl.Gain] rIG , reduce the proportional gain [PID Prop.Gain] rPG in the event of instability (pump applications), find a compromise between response time and static precision (see diagram).
10	Lastly, the derivative gain may permit the overshoot to be reduced and the response time to be improved, although this is more difficult to obtain a compromise in terms of stability, as it depends on 3 gains.
11	Perform in-production tests over the whole reference range.

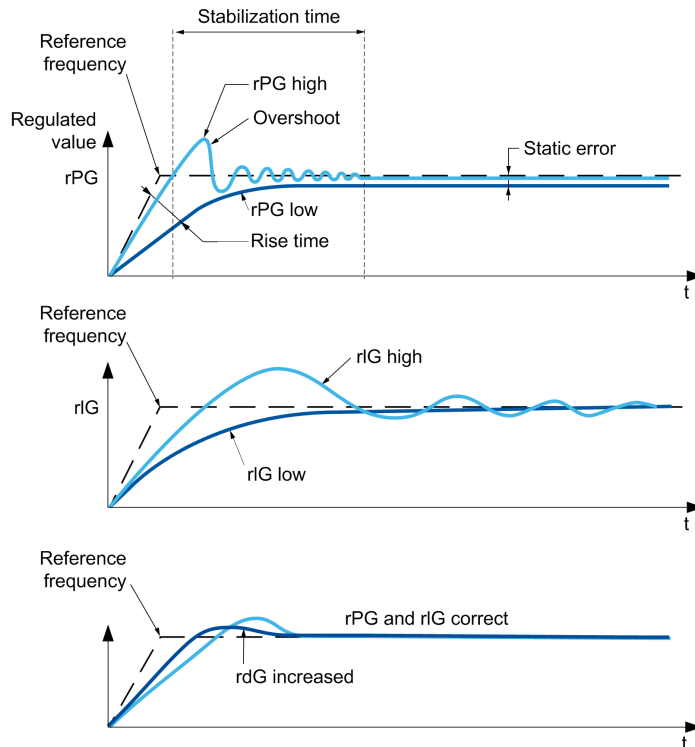

The oscillation frequency depends on the system kinematics:

Parameter	Rise time	Overshoot	Stabilization time	Static error
rPG +	--	+	=	-
rIG +	-	++	+	--
rdG +	=	-	-	=

[PID Feedback] F d b - Menu

Access

[Complete settings] → [Pump functions] → [PID controller] → [PID Feedback]

About This Menu

NOTE: This function cannot be used with some other functions.

[Type of Control] t o c t

Type of control for the PID = unit choice.

Setting	Code / Value	Description
[nA]	n A	(without unit) Factory setting
[Pressure]	P r E S S	Pressure control and unit
[Flow]	F L o W	Flow control and unit
[Other]	o t H E r	Other control and unit (%)

[PID feedback Assign] P , F

PID controller feedback.

Setting	Code / Value	Description
[No]	n o	Not assigned Factory setting
[AI1]...[AI3]	A , 1 ... A , 3	Analog input AI1...AI3
[AI4]...[AI5]	A , 4 ... A , 5	Analog input AI4...AI5 if VW3A3203 I/O extension module has been inserted
[AI Virtual 1]... [AI Virtual 3]	A , V 1 ... A , V 3	Virtual analogic input 1...3
[PulseInput Assignment On DI5]... [PulseInput Assignment On DI6]	P , 5 ... P , 6	Digital input DI5...DI6 used as pulse input

[AI1 Type] A , 1 t ★

Configuration of analog input AI1.

This parameter can be accessed if [PID feedback Assign] P , F is set to [AI1] A , 1.

Setting	Code / Value	Description
[Voltage]	V o l t	0-10 Vdc Factory setting
[Current]	C u r	0-20 mA

Setting	Code / Value	Description
[PTC Management]	P L C	1 to 6 PTC (in serial)
[KTY]	K L Y	1 KTY84
[PT100]	P L 2	1 PT100 connected with 2 wires
[PT1000]	P L 3	1 PT1000 connected with 2 wires

[AI1 min value] u , L I★

AI1 voltage scaling parameter of 0%.

This parameter can be accessed if:

- [PID feedback Assign] P , F is set to [AI1] R , I, and
- [AI1 Type] R , I L is set to [Voltage] I D u .

Setting	Description
0.0...10.0 Vdc	Setting range Factory setting: 0.0 Vdc

[AI1 max value] u , H I★

AI1 voltage scaling parameter of 100%.

This parameter can be accessed if:

- [PID feedback Assign] P , F is set to [AI1] R , I, and
- [AI1 Type] R , I L is set to [Voltage] I D u .

Setting	Description
0.0...10.0 Vdc	Setting range Factory setting: 10.0 Vdc

[AI1 min. value] C r L I★

AI1 current scaling parameter of 0%.

This parameter can be accessed if:

- [PID feedback Assign] P , F is set to [AI1] R , I, and
- [AI1 Type] R , I L is set to [Current] D R .

Setting	Description
0.0...20.0 mA	Setting range Factory setting: 0.0 mA

[AI1 max. value] C r H I★

AI1 current scaling parameter of 100%.

This parameter can be accessed if:

- [PID feedback Assign] P , F is set to [AI1] R , I, and
- [AI1 Type] R , I L is set to [Current] D R .

Setting	Description
0.0...20.0 mA	Setting range Factory setting: 20.0 mA

[AI1 range] R , 1 L ★

AI1 scaling selection.

This parameter can be accessed if:

- **[PID feedback Assign] P , F** is set to **[AI1] R , 21**, and
- **[AI1 Type] R , 1 E** is set to **[Current] 0 R**.

This parameter is forced to **[0-100%] P 0 S** if:

- **[AI1 Type] R , 1 E** is not set to **[Current] 0 R**, or
- **[AI1 min. value] C r L 1** is lower than 3.0 mA.

Setting	Code / Value	Description
[0-100%]	<i>P 0 S</i>	Unidirectional: AI1 current scaling is 0% up to 100%. Factory setting
[-/+100%]	<i>P 0 S n E G</i>	Bidirectional: AI1 current scaling is -100% up to 100%. [AI1 min. value] C r L 1 corresponds to -100%. [AI1 max. value] C r H 1 corresponds to 100%.

[AI2 Type] R , 2 E ★

Configuration of analog input AI2.

This parameter can be accessed if **[PID feedback Assign] P , F** is set to **[AI2] R , 2**.

Setting	Code / Value	Description
[Voltage]	<i>1 0 v</i>	0-10 Vdc Factory setting
[Current]	<i>0 R</i>	0-20 mA
[PTC Management]	<i>P E C</i>	1 to 6 PTC (in serial)
[KTY]	<i>K E Y</i>	1 KTY84
[PT1000]	<i>1 P E 3</i>	1 PT1000 connected with 2 wires
[PT100]	<i>1 P E 2</i>	1 PT100 connected with 2 wires
[Water Prob]	<i>L E v E L</i>	Water level
[3PT1000]	<i>3 P E 3</i>	3 PT1000 connected with 2 wires
[3PT100]	<i>3 P E 2</i>	3 PT100 connected with 2 wires

[AI2 min value] v , L 2 ★

AI2 voltage scaling parameter of 0%.

This parameter can be accessed if:

- **[PID feedback Assign] P , F** is set to **[AI2] R , 2**, and
- **[AI2 Type] R , 2 E** is set to **[Voltage] 1 0 v**.

Identical to **[AI1 min value] v , L 1**, page 311.

[AI2 max value] U , H 2★

AI2 voltage scaling parameter of 100%.

This parameter can be accessed if:

- **[PID feedback Assign] P , F** is set to **[AI2] R , 2**, and
- **[AI2 Type] R , 2 E** is set to **[Voltage] I 0 U**.

Identical to **[AI1 max value] U , H 1**, page 311.

[AI2 min. value] C r L 2★

AI2 current scaling parameter of 0%.

This parameter can be accessed if:

- **[PID feedback Assign] P , F** is set to **[AI2] R , 2**, and
- **[AI2 Type] R , 2 E** is not set to **[Current] 0 R**.

Identical to **[AI1 min. value] C r L 1**, page 311.

[AI2 max. value] C r H 2★

AI2 current scaling parameter of 100%.

This parameter can be accessed if:

- **[PID feedback Assign] P , F** is set to **[AI2] R , 2**, and
- **[AI2 Type] R , 2 E** is not set to **[Current] 0 R**.

Identical to **[AI1 max. value] C r H 1**, page 311.

[AI2 range] R , 2 L

AI2 scaling selection.

This parameter can be accessed if :

- **[PID feedback Assign] P , F** is set to **[AI2] R , 2**, and
- **[AI2 Type] R , 2 E** is set to **[Current] 0 R**.

Identical to **[AI1 range] R , 1 L**, page 205.

[AI3 Type] R , 3 E★

Configuration of analog input AI3.

This parameter can be accessed if **[PID feedback Assign] P , F** is set to **[AI3] R , 3**.

Identical to **[AI1 Type] R , 1 E** with factory setting: **[Current] 0 R**, page 312.

[AI3 min value] U , L 3★

AI3 voltage scaling parameter of 0%.

This parameter can be accessed if:

- **[PID feedback Assign] P , F** is set to **[AI3] R , 3**, and
- **[AI3 Type] R , 3 E** is set to **[Voltage] I 0 U**.

Identical to **[AI1 min value] U , L 1**, page 311.

[AI3 max value] U , H E ★

AI3 voltage scaling parameter of 100%.

This parameter can be accessed if:

- **[PID feedback Assign] P , F** is set to **[AI3] R , E**, and
- **[AI3 Type] R , E E** is set to **[Voltage] I D U**.

Identical to **[AI1 max value] U , H I**, page 311.

[AI3 min. value] C r L E ★

AI3 current scaling parameter of 0%.

This parameter can be accessed if:

- **[PID feedback Assign] P , F** is set to **[AI3] R , E**, and
- **[AI3 Type] R , E E** is set to **[Current] D R**.

Identical to **[AI1 min. value] C r L I**, page 311.

[AI3 max. value] C r H E ★

AI3 current scaling parameter of 100%.

This parameter can be accessed if:

- **[PID feedback Assign] P , F** is set to **[AI3] R , E**, and
- **[AI3 Type] R , E E** is set to **[Current] D R**.

Identical to **[AI1 max. value] C r H I**, page 311.

[AI3 range] R , E L

AI3 scaling selection.

This parameter can be accessed if :

- **[PID feedback Assign] P , F** is set to **[AI3] R , E**, and
- **[AI3 Type] R , E E** is set to **[Current] D R**.

Identical to **[AI1 range] R , I L**, page 205.

[AI4 Type] R , 4 E ★

Configuration of analog input AI4.

This parameter can be accessed if:

- VW3A3203 I/O extension module has been inserted, and
- **[PID feedback Assign] P , F** is set to **[AI4] R , 4**.

Setting	Code / Value	Description
[Voltage]	I D U	0-10 Vdc
[Current]	D R	0-20 mA
[Voltage +/-]	n I D U	-10/+10 Vdc Factory setting

[AI4 min value] U , L 4★

AI4 voltage scaling parameter of 0%.

This parameter can be accessed if:

- **[PID feedback Assign] P , F** is set to **[AI4] R , 4**, and
- **[AI4 Type] R , 4 E** is set to **[Voltage] I 0 U**.

Identical to **[AI1 min value] U , L 1**, page 311.

[AI4 max value] U , H 4★

AI4 voltage scaling parameter of 100%.

This parameter can be accessed if:

- **[PID feedback Assign] P , F** is set to **[AI4] R , 4**, and
- **[AI4 Type] R , 4 E** is set to **[Voltage] I 0 U**.

Identical to **[AI1 max value] U , H 1**, page 311.

[AI4 min. value] C r L 4★

AI4 current scaling parameter of 0%.

This parameter can be accessed if:

- **[PID feedback Assign] P , F** is set to **[AI4] R , 4**, and
- **[AI4 Type] R , 4 E** is set to **[Current] 0 R**.

Identical to **[AI1 min. value] C r L 1**, page 311.

[AI4 max. value] C r H 4★

AI4 current scaling parameter of 100%.

This parameter can be accessed if:

- **[PID feedback Assign] P , F** is set to **[AI4] R , 4**, and
- **[AI4 Type] R , 4 E** is not set to **[Current] 0 R**.

Identical to **[AI1 max. value] C r H 1**, page 311.

[AI4 range] R , 4 L

AI4 scaling selection.

This parameter can be accessed if :

- **[PID feedback Assign] P , F** is set to **[AI4] R , 4**, and
- **[AI4 Type] R , 4 E** is set to **[Current] 0 R**.

Identical to **[AI1 range] R , 1 L**, page 205.

[AI5 Type] R , 5 E★

Configuration of analog input AI5.

This parameter can be accessed if:

- VW3A3203 I/O extension module has been inserted, and
- **[PID feedback Assign] P , F** is set to **[AI5] R , 5**.

Identical to **[AI4 Type] R , 4 E**, page 314.

[AI5 min value] U , L 5 ★

AI5 voltage scaling parameter of 0%.

This parameter can be accessed if:

- **[PID feedback Assign] P , F** is set to **[AI5] R , S**, and
- **[AI5 Type] R , S E** is set to **[Voltage] I D U**.

Identical to **[AI1 min value] U , L 1**, page 311.

[AI5 max value] U , H 5 ★

AI5 voltage scaling parameter of 100%.

This parameter can be accessed if:

- **[PID feedback Assign] P , F** is set to **[AI5] R , S**, and
- **[AI5 Type] R , S E** is set to **[Voltage] I D U**.

Identical to **[AI1 max value] U , H 1**, page 311.

[AI5 min. value] C r L 5 ★

AI5 current scaling parameter of 0%.

This parameter can be accessed if:

- **[PID feedback Assign] P , F** is set to **[AI5] R , S**, and
- **[AI5 Type] R , S E** is set to **[Current] D R**.

Identical to **[AI1 min. value] C r L 1**, page 311.

[AI5 max. value] C r H 5 ★

AI5 current scaling parameter of 100%.

This parameter can be accessed if:

- **[PID feedback Assign] P , F** is set to **[AI5] R , S**, and
- **[AI5 Type] R , S E** is set to **[Current] D R**.

Identical to **[AI1 max. value] C r H 1**, page 311.

[AI5 range] R , S L

AI5 scaling selection.

This parameter can be accessed if :

- **[PID feedback Assign] P , F** is set to **[AI5] R , S**, and
- **[AI5 Type] R , S E** is set to **[Current] D R**.

Identical to **[AI1 range] R , I L**, page 205.

[Min PID feedback] P , F 1 ★

Minimum PID feedback.

This parameter can be accessed if **[PID feedback Assign] P , F** is not set to **[No] n o**.

Setting ()	Description
0...[Max PID feedback] <i>P , F 2</i>	Setting range Factory setting: 100

[Max PID feedback] *P , F 2*★

Maximum PID feedback.

This parameter can be accessed if [PID feedback Assign] *P , F* is not set to [No] *n o*.

Setting ()	Description
[Min PID feedback] <i>P , F 1</i> ...32,767	Setting range Factory setting: 1,000

[PID feedback] *r P F*★

Value for PID feedback, display only.

This parameter can be accessed if [PID feedback Assign] *P , F* is not set to [No] *n o*.

Setting	Description
0...65,535	Setting range Factory setting: _

[Min Fbk Warning] *P R L*★

Minimum feedback level warning.

This parameter can be accessed if [PID feedback Assign] *P , F* is not set to [No] *n o*. [PID Low Fdbck Warning] *P F R L* warning is active if the value of the PID feedback is lower than the value configured in [Min Fbk Warning] *P R L*.

Setting ()	Description
0...65,535	Setting range Factory setting: 100

[Max Fbk Warning] *P R H*★

Maximum feedback level warning.

This parameter can be accessed if [PID feedback Assign] *P , F* is not set to [No] *n o*. [PID High Fdbck Warning] *P F R H* warning is active if the value of the PID feedback is greater than the value configured in [Max Fbk Warning] *P R H*.

Setting ()	Description
0...65,535	Setting range Factory setting: 1,000

[PID Reference] r F - Menu

Access

[Complete settings] \rightarrow [Pump functions] \rightarrow [PID controller] \rightarrow [PID Reference]

About This Menu

NOTE: This function cannot be used with some other functions.

[Intern PID Ref] P , i , \star

Internal PID controller reference.

This parameter can be accessed if [PID feedback Assign] P , F is not set to [Not Configured] $n o$.

Setting	Code / Value	Description
[No]	$n o$	The PID controller reference is given by [Ref Freq 1 Config] $F r 1$ or [Ref.1B channel] $F r 1 b$ with summing/subtraction/multiplication functions. Refer to the block diagram, page 306. Factory setting
[Yes]	$y e s$	The PID controller reference is internal via [Internal PID ref] $r P i$.

[Ref Freq 1 Config] $F r 1$ \star

Configuration reference frequency 1.

This parameter can be accessed if:

- [PID feedback Assign] P , F is not set to [Not Configured] $n o$, and
- [Intern PID Ref] P , i is set to [No] $n o$.

Setting	Code / Value	Description
[Not Configured]	$n o$	Not assigned
[AI1]	$A i 1$	Analog input AI1 Factory Setting
[AI2]...[AI3]	$A i 2$... $A i 3$	Analog input AI2...AI3
[AI Virtual 1]...[AI Virtual 3]	$A i v 1$... $A i v 3$	Virtual analogic input 1...3
[AI4]...[AI5]	$A i 4$... $A i 5$	Analog input AI4...AI5 if VW3A3203 I/O extension module has been inserted
[Ref.Freq-Rmt. Term]	$L C C$	Reference Frequency via remote terminal
[Ref. Freq-Modbus]	$M d b$	Reference frequency via Modbus
[Ref. Freq-CANopen]	$C A n$	Reference frequency via CANopen if a CANopen module has been inserted
[Ref. Freq-Com. Module]	$n E t$	Reference frequency via fieldbus module if a fieldbus module has been inserted

Setting	Code / Value	Description
[Embedded Ethernet]	E L H	Embedded Ethernet
[DI5 PulseInput Assignment]... [DI6 PulseInput Assignment]	P , 5... P , 6	Digital input DI5...DI6 used as pulse input

[Min PID reference] P , P 1★

Minimum PID reference.

This parameter can be accessed if [PID feedback Assign] P , F is not set to [Not Configured] n o .

Setting ()	Description
[Min PID feedback] P , F 1... [Max PID reference] P , P 2	Setting range Factory setting: 150

[Max PID reference] P , P 2★

Maximum PID reference.

This parameter can be accessed if [PID feedback Assign] P , F is not set to [Not Configured] n o .

Setting ()	Description
[Min PID reference] P , P 1... [Max PID feedback] P , F 2	Setting range Factory setting: 900

[Internal PID ref] r P , ★

Internal PID controller reference.

This parameter can be accessed if:

- [PID feedback Assign] P , F is not set to [Not Configured] n o , and
- [Intern PID Ref] P , r is set to [Yes] Y E 5 .

Setting ()	Description
[Min PID reference] P , P 1... [Max PID reference] P , P 2	Setting range Factory setting: 150

[Auto/Manual assign.] P A u★

Auto/Manual select input.

This parameter can be accessed if [PID feedback Assign] P , F is not set to [Not Configured] n o .

Setting	Code / Value	Description
[Not Assigned]	n o	Not assigned Factory setting
[DI1]...[DI6]	L , 1...L , 6	Digital input DI1...DI6
[DI11]...[DI16]	L , 11... L , 16	Digital input DI11...DI16 if VW3A3203 I/O extension module has been inserted
[CD00]... [CD10]	C d 0 0... C d 1 0	Virtual digital input CMD.0...CMD.10 in [I/O profile] , o configuration
[CD11]... [CD15]	C d 1 1... C d 1 5	Virtual digital input CMD.11...CMD.15 regardless of configuration
[C101]... [C110]	C 1 0 1... C 1 1 0	Virtual digital input CMD1.01...CMD1.10 with integrated Modbus Serial in [I/O profile] , o configuration
[C111]... [C115]	C 1 1 1... C 1 1 5	Virtual digital input CMD1.11...CMD1.15 with integrated Modbus Serial regardless of configuration
[C201]... [C210]	C 2 0 1... C 2 1 0	Virtual digital input CMD2.01...CMD2.10 with CANopen® fieldbus module in [I/O profile] , o configuration
[C211]... [C215]	C 2 1 1... C 2 1 5	Virtual digital input CMD2.11...CMD2.15 with CANopen® fieldbus module regardless of configuration
[C301]... [C310]	C 3 0 1... C 3 1 0	Virtual digital input CMD3.01...CMD3.10 with a fieldbus module in [I/O profile] , o configuration
[C311]... [C315]	C 3 1 1... C 3 1 5	Virtual digital input CMD3.11...CMD3.15 with a fieldbus module regardless of configuration
[C501]... [C510]	C 5 0 1... C 5 1 0	Virtual digital input CMD5.01...CMD5.10 with integrated Ethernet in [I/O profile] , o configuration
[C511]... [C515]	C 5 1 1... C 5 1 5	Virtual digital input CMD5.11...CMD5.15 with integrated Ethernet regardless of configuration

[Manual PID Reference] P , n★

Manual PID reference.

Reference input in manual mode.

This parameter can be accessed if:

- **[PID feedback Assign] P , F** is not set to **[Not Configured] n o**, and
- **[Auto/Manual assign.] P R u** is not set to **[No] n o**.

The preset speeds are active on the manual reference if they have been configured.

Setting	Code / Value	Description
[No]	n o	Not assigned Factory setting
[AI1]...[AI3]	A , 1...A , 3	Analog input AI1...AI3
[AI4]...[AI5]	A , 4...A , 5	Analog input AI4...AI5 if VW3A3203 I/O extension module has been inserted
[PulseInput Assignment On DI5]... [PulseInput Assignment On DI6]	P , 5...P , 6	Digital input DI5...DI6 used as pulse input

[PID preset references] *P r , - Menu*

Access

[Complete settings] → [Pump functions] → [PID controller] → [PID Reference] → [PID preset references]

About This Menu

The function can be accessed if [PID feedback Assign] *P , F* is assigned.

[2 PID Preset Assign] *P r 2*

2 PID preset assignment.

If the assigned input or bit is at 0, the function is inactive.

If the assigned input or bit is at 1, the function is active.

Setting	Code / Value	Description
[Not Assigned]	<i>n o</i>	Not assigned Factory setting
[DI1]...[DI6]	<i>L , 1...L , 6</i>	Digital input DI1...DI6
[DI11]...[DI16]	<i>L , 11... L , 16</i>	Digital input DI11...DI16 if VW3A3203 I/O extension module has been inserted
[CD00]... [CD10]	<i>C d 0 0... C d 1 0</i>	Virtual digital input CMD.0...CMD.10 in [I/O profile] , <i>o</i> configuration
[CD11]... [CD15]	<i>C d 1 1... C d 1 5</i>	Virtual digital input CMD.11...CMD.15 regardless of configuration
[C101]... [C110]	<i>C 1 0 1... C 1 1 0</i>	Virtual digital input CMD1.01...CMD1.10 with integrated Modbus Serial in [I/O profile] , <i>o</i> configuration
[C111]... [C115]	<i>C 1 1 1... C 1 1 5</i>	Virtual digital input CMD1.11...CMD1.15 with integrated Modbus Serial regardless of configuration
[C201]... [C210]	<i>C 2 0 1... C 2 1 0</i>	Virtual digital input CMD2.01...CMD2.10 with CANopen® fieldbus module in [I/O profile] , <i>o</i> configuration
[C211]... [C215]	<i>C 2 1 1... C 2 1 5</i>	Virtual digital input CMD2.11...CMD2.15 with CANopen® fieldbus module regardless of configuration
[C301]... [C310]	<i>C 3 0 1... C 3 1 0</i>	Virtual digital input CMD3.01...CMD3.10 with a fieldbus module in [I/O profile] , <i>o</i> configuration
[C311]... [C315]	<i>C 3 1 1... C 3 1 5</i>	Virtual digital input CMD3.11...CMD3.15 with a fieldbus module regardless of configuration
[C501]... [C510]	<i>C 5 0 1... C 5 1 0</i>	Virtual digital input CMD5.01...CMD5.10 with integrated Ethernet in [I/O profile] , <i>o</i> configuration
[C511]... [C515]	<i>C 5 1 1... C 5 1 5</i>	Virtual digital input CMD5.11...CMD5.15 with integrated Ethernet regardless of configuration

[4 PID Preset Assign] *P r 4*

4 PID preset assignment.

Identical to [2 PID Preset Assign] *P r 2* , page 321.

Verify that [2 PID Preset Assign] *P r 2* has been assigned before assigning this function.

[Ref PID Preset 2] r P 2★

Second PID preset reference.

This parameter can be accessed only if **[2 PID Preset Assign]** P r 2 is assigned.

Setting ()	Description
[Min PID reference] P , P 1... [Max PID reference] P , P 2	Setting range Factory setting: 300

[Ref PID Preset 3] r P 3★

Third PID preset reference.

This parameter can be accessed only if **[4 preset PID ref.]** P r 4 is assigned.

Setting ()	Description
[Min PID reference] P , P 1... [Max PID reference] P , P 2	Setting range Factory setting: 600

[Ref PID Preset 4] r P 4★

Fourth PID preset reference.

This parameter can be accessed only if **[2 preset PID ref.]** P r 2 and **[4 preset PID ref.]** P r 4 are assigned.

Setting ()	Description
[Min PID reference] P , P 1... [Max PID reference] P , P 2	Setting range Factory setting: 900

[PID Reference] *r F - Menu*

Access

[Complete settings] → [Pump functions] → [PID controller] → [PID Reference]

[Predictive Speed Ref] *F P , ★*

Predictive speed reference.

This parameter can be accessed if:

- [Access Level] *L R C* is set to [Expert] *E P r*.
- [PID feedback] *P , F* is not set to [No] *n o*.

Setting	Code / Value	Description
[Not Configured]	<i>n o</i>	Not assigned Factory setting
[AI1]...[AI3]	<i>A , 1...A , 3</i>	Analog input AI1...AI3
[AI4]...[AI5]	<i>A , 4...A , 5</i>	Analog input AI4...AI5 if VW3A3203 I/O extension module has been inserted
[Ref. Freq-Rmt.Term]	<i>L C C</i>	Reference frequency via remote terminal
[Ref. Freq-Modbus]	<i>n d b</i>	Reference frequency via Modbus
[Ref. Freq-CANopen]	<i>C A n</i>	Reference frequency via CANopen
[Ref. Freq-Com. Module]	<i>n E E</i>	Reference frequency via communication module
[Embedded Ethernet]	<i>E E H</i>	Embedded Ethernet
[PulseInput Assignment On DI5]... [PulseInput Assignment On DI6]	<i>P , 5...P , 6</i>	Digital input DI5...DI6 used as pulse input

[Speed Input %] *P 5 r ★*

PID speed input % reference.

- This parameter can be accessed if [Access Level] *L R C* is set to [Expert] *E P r*, and
- [Predictive Speed Ref] *F P ,* is not set to [Not Configured] *n o*.

Setting ()	Description
1...100%	Setting range Factory setting: 100%

[Settings] 5 5 - Menu

Access

[Complete settings] → [Pump functions] → [PID controller] → [Settings]

About This Menu

Following parameters can be accessed if [PID Feedback] $P_r F$ is not set to [Not Configured] $n o$.

NOTE: This function cannot be used with some other functions.

[PID Prop.Gain] $r P G$ ★

Proportional gain.

Setting ()	Description
0.01...100.00	Setting range Factory setting: 1.00

[PI Intgl.Gain] $r I G$ ★

Integral gain.

Setting ()	Description
0.01...100.00	Setting range Factory setting: 1.00

[PID derivative gain] $r d G$ ★

Derivative gain.

Setting ()	Description
0.00...100.00	Setting range Factory setting: 0.00

[PID ramp] $P_r P$ ★

PID acceleration/deceleration ramp, defined to go from [Min PID reference] $P_r P 1$ to [Max PID reference] $P_r P 2$ and conversely.

Setting ()	Description
0.0...99.9 s	Setting range Factory setting: 0.0 s

[PID Inversion] $P_r I$ ★

PID inversion.

Setting	Code / Value	Description
[No]	<i>n o</i>	No Factory setting
[Yes]	<i>y e s</i>	Yes

[PID Min Output] *P o L* ★

PID controller minimum output in Hz.

Setting ()	Description
-500.0...500.0 Hz	Setting range Factory setting: 0.0 Hz

[PID Max Output] *P o H* ★

PID controller maximum output in Hz.

Setting ()	Description
0.0...500.0 Hz	Setting range Factory setting: 60.0 Hz

[PID Error Warning] *P E r* ★

PID error warning. **[PID Error Warning] *P E E*** is active if the value of PID error is greater than the value configured in **[PID Error Warning] *P E r***.

Setting ()	Description
0...65,535	Setting range Factory setting: 100

[PID Integral OFF] *P , S* ★

Integral shunt.

If the assigned input or bit is at 0, the function is inactive (the PID integral is enabled).

If the assigned input or bit is at 1, the function is active (the PID integral is disabled).

Setting	Code / Value	Description
[Not Assigned]	<i>n o</i>	Not assigned Factory setting
[DI1]...[DI6]	<i>L , 1...L , 6</i>	Digital input DI1...DI6
[DI11]...[DI16]	<i>L , 11...L , 16</i>	Digital input DI11...DI16 if VW3A3203 I/O extension module has been inserted
[CD00]... [CD10]	<i>C d 0 0...C d 1 0</i>	Virtual digital input CMD.0...CMD.10 in [I/O profile] , o configuration
[CD11]... [CD15]	<i>C d 1 1...C d 1 5</i>	Virtual digital input CMD.11...CMD.15 regardless of configuration

Setting	Code / Value	Description
[C101]... [C110]	C 1 0 1... C 1 1 0	Virtual digital input CMD1.01...CMD1.10 with integrated Modbus Serial in [I/O profile] configuration
[C111]... [C115]	C 1 1 1... C 1 1 5	Virtual digital input CMD1.11...CMD1.15 with integrated Modbus Serial regardless of configuration
[C201]... [C210]	C 2 0 1... C 2 1 0	Virtual digital input CMD2.01...CMD2.10 with CANopen® fieldbus module in [I/O profile] configuration
[C211]... [C215]	C 2 1 1... C 2 1 5	Virtual digital input CMD2.11...CMD2.15 with CANopen® fieldbus module regardless of configuration
[C301]... [C310]	C 3 0 1... C 3 1 0	Virtual digital input CMD3.01...CMD3.10 with a fieldbus module in [I/O profile] configuration
[C311]... [C315]	C 3 1 1... C 3 1 5	Virtual digital input CMD3.11...CMD3.15 with a fieldbus module regardless of configuration
[C501]... [C510]	C 5 0 1... C 5 1 0	Virtual digital input CMD5.01...CMD5.10 with integrated Ethernet in [I/O profile] configuration
[C511]... [C515]	C 5 1 1... C 5 1 5	Virtual digital input CMD5.11...CMD5.15 with integrated Ethernet regardless of configuration

[PID acceleration time] A C C P ★

PID: acceleration during start-up.

PID start ramp can be applied before starting the PID controller to allow reaching quickly the PID reference without increasing PID gains. If configured, the [Start Accel Ramp] A C C S is applied up to [Low Speed] L 5 P instead of [PID acceleration time] A C C P.

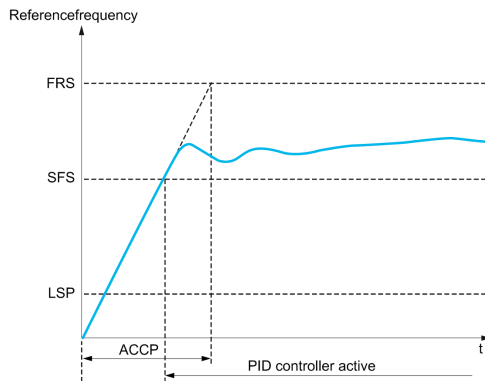

Setting (C)	Description
0.01...99.99 s (1)	Setting range Factory setting: 5.00 s
1 Range 0.01 to 99.99 s or 0.1 to 999.9 s or 1...6,000 s according to [Ramp increment] D C .	

[PID Start Ref Freq] S F S ★

PID: speed reference for start-up.

Setting (C)	Description
0.0...500.0 Hz	Setting range If [PID Start Ref Freq] S F S is lower than [Low speed] L 5 P, this function has no effect. Factory setting: 0.0 Hz

[Pump functions] - [Sleep/wakeup]

[Sleep/Wakeup] \llcorner \llcorner \llcorner - Overview

About This Menu

Following parameters can be accessed if [PID feedback Assign] \llcorner \llcorner \llcorner is not set to [Not Configured] \llcorner \llcorner \llcorner .

⚠ WARNING

UNANTICIPATED EQUIPMENT OPERATION

Verify that activating this function does not result in unsafe conditions.

Failure to follow these instructions can result in death, serious injury, or equipment damage.

The purpose of the "Sleep / Wake-Up" function is to stop the motor in process standstill situations.

It allows you to save energy and helps to prevent premature aging of some equipment that cannot run for a long time at low speed because the greasing or cooling depends on the machine speed.

In a pressure-controlled pumping application:

- The purpose of the Sleep / Wake-Up function is to manage periods of the application where the water demand is low and where it is not needed to keep the main pumps running.
- It allows you to save energy in low demand periods. Then, when the demand is increasing, the application needs to wake up in order to meet the demand.
- Optionally, during a sleep period, a Jockey pump can be started to maintain an emergency service pressure or meet a low water demand.

Depending on user-defined wakeup conditions, the motor is restarted automatically.

Sleep/Wake-Up in PID Control Mode

When the drive is used in PID control, one of the following conditions is used to switch the application to the sleep state:

- Sleep on low speed (when all fixed pumps are Off in case of a multi-pump application).
- Sleep on low sleep sensor value (using flow sensor for monitoring).
- Sleep on low motor power (when all fixed pumps are Off in case of a multi-pump application).
- Sleep on external condition (using drive input).

The drive is in "PID control mode" when PID is active. Typically when:

- PID is configured, and
- Channel 1 is selected, and
- PID is in automatic mode.

When the drive is in a sleep state, a wake-up condition is used to restart the application:

- Wake-up on PID Feedback level
- Wake-up on PID Error level
- Wake-up on low-pressure condition

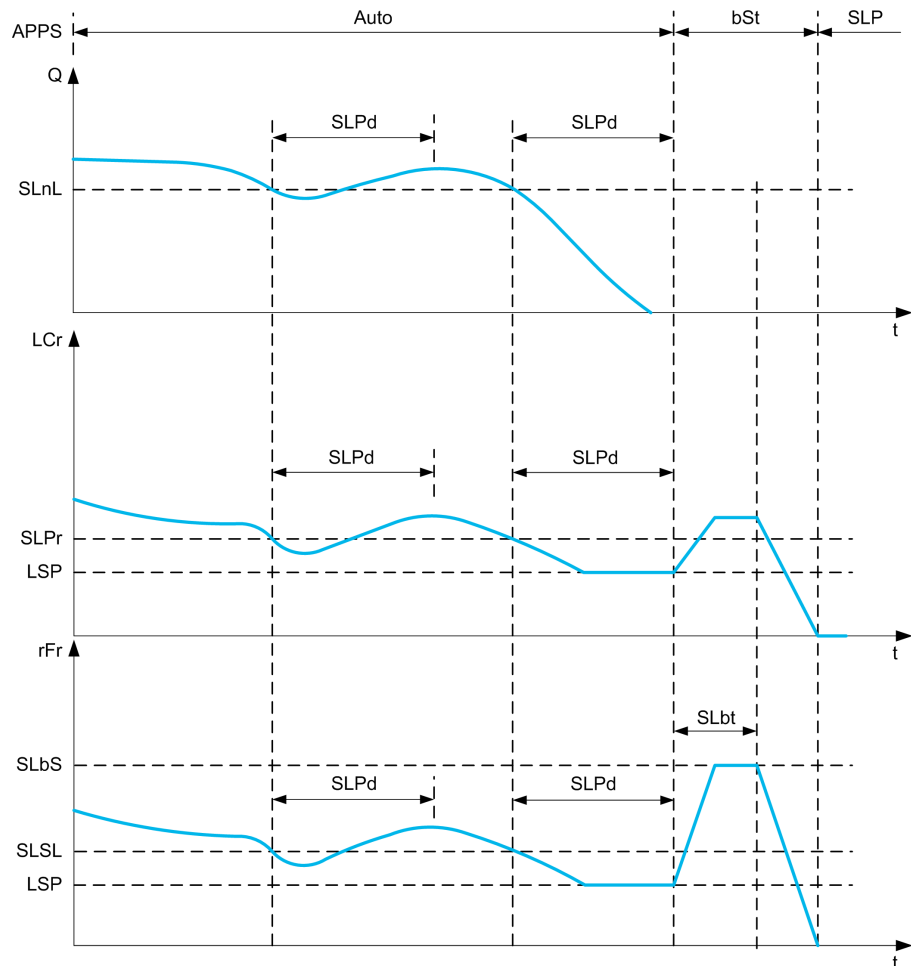

Sleep Conditions in PID Control Mode

If there is no valid wake-up condition, then the system switches to the sleep mode after one of the configured sleep conditions remains longer than **[Sleep Delay]** $5 L P d$.

Additionally, in case of multi pump system, if the **[Type of control]** $\epsilon \square \epsilon$ is different from **[Flow]** $F L \square W$, the system requires all auxiliary pumps to be stopped in order to switch to the sleep mode.

The sleep detection mode is selected by configuring **[Sleep Detect Mode]** $5 L P \Pi$. Then the system switches to sleep mode if the selected condition is met:

Configuration	Condition
$L F$ sleep on flow sensor value	Sensor value is below the sleep level
$5 W$ sleep on switch or external condition	The switch input becomes active
$5 P d$ sleep on speed	The output frequency is below the sleep speed
$P W r$ sleep on power level	The output power is below the sleep power
$H P$ sleep on pressure sensor value	Sensor value is higher than the sleep level
$\square r$ multiple conditions	At least 1 of the configured condition to enter in sleep mode is met

Wake-Up Conditions in PID Control Mode

The system wakes up according to **[Wake Up Mode]** $w \square P \Pi$ configuration:

- On PID Feedback level

- On PID Error level.
- On low-pressure condition.

The system wakes up if the wake up conditions are valid for a time longer than the **[Wake Up Delay] $\mathcal{W} \mathcal{U} \mathcal{P} \mathcal{d}$** .

If **[Feedback] $\mathcal{F} \mathcal{b} \mathcal{K}$** is selected, then the system wakes up and goes back in PID control mode:

- When PID feedback drops below configured **[Wake Up Process Level] $\mathcal{W} \mathcal{U} \mathcal{P} \mathcal{F}$** if PID is configured in Direct mode, (**[PID Inversion] $\mathcal{P} \mathcal{I} \mathcal{C}$** is set to $\mathcal{n} \mathcal{o}$).
- When PID feedback raises above configured **[Wake Up Process Level] $\mathcal{W} \mathcal{U} \mathcal{P} \mathcal{F}$** , if PID is configured in Reverse mode (**[PID Inversion] $\mathcal{P} \mathcal{I} \mathcal{C}$** is set to $\mathcal{Y} \mathcal{E} \mathcal{S}$).

If **[Error] $\mathcal{E} \mathcal{r} \mathcal{r}$** is selected, then the system wakes up and goes back in PID control mode:

- When PID feedback drops below (**[PID reference] $\mathcal{r} \mathcal{P} \mathcal{C}$** - **[Wake Up Process Error] $\mathcal{W} \mathcal{U} \mathcal{P} \mathcal{E}$**), if PID is configured in Direct mode (**[PID Inversion] $\mathcal{P} \mathcal{I} \mathcal{C}$** is set to $\mathcal{n} \mathcal{o}$).
- When PID feedback raises above (**[PID reference] $\mathcal{r} \mathcal{P} \mathcal{C}$** + **[Wake Up Process Error] $\mathcal{W} \mathcal{U} \mathcal{P} \mathcal{E}$**), if PID is configured in Reverse mode (**[PID Inversion] $\mathcal{P} \mathcal{I} \mathcal{C}$** is set to $\mathcal{Y} \mathcal{E} \mathcal{S}$).

If **[Pressure] $\mathcal{L} \mathcal{P}$** is selected, then the system wakes up and goes back in PID control mode when the pressure feedback drops below **[Wake Up Process Level] $\mathcal{W} \mathcal{U} \mathcal{P} \mathcal{F}$** .

Boosting Phase in PID Control Mode

When entering the sleep mode, the motor accelerates to **[Sleep Boost Speed] $\mathcal{S} \mathcal{L} \mathcal{b} \mathcal{S}$** during **[Sleep Boost Time] $\mathcal{S} \mathcal{L} \mathcal{b} \mathcal{t}$** and then stops.

If **[Sleep Boost Time] $\mathcal{S} \mathcal{L} \mathcal{b} \mathcal{t}$** is set to 0, then the boost phase is ignored.

Initial State in PID Control Mode

Just after the system starts in automatic mode (a run order appears while in automatic mode - channel 1 already selected and PID auto):

- If a wake-up condition is met, the drive goes in PID control mode (PID started).
- If a wake-up condition is not met, the drive goes in sleep mode (PID stays stopped and motor is kept halted), and Boosting phase is ignored.

When the control is switched to automatic mode while the motor is running (switch to channel 1 or switch to PID auto mode for example), the drive stays in running state and switches to PID automatic mode.

Configuration of Sleep External Condition (Usage of a No Flow Switch for Example)

Sleep switch allows you to select the source of sleep external condition:

- $\mathcal{n} \mathcal{o}$: no input selected for the sleep external condition.
- $\mathcal{d} \mathcal{I} \mathcal{X}$: the sleep external condition (switch for example) is connected to DIx (the assignment is also possible on a control bit in I/O profile).

Configuration of Sleep Sensor (Flow or Pressure Sensor)

The assignment of a sleep sensor, the configuration of the selected physical input and the configuration of scaling to process value are performed.

A sleep sensor source is selected by **[Inst. Flow Assign.] F 5 1 R** and **[OutletPres Assign] P 5 2 R** which allows to select the analog or pulse input on which the sensor is connected:

- **n 0**: no input selected for sleep sensor value.
- **R 1 X**: sleep sensor is connected to AIx.
- **R 1 u X**: sleep sensor is connected to virtual AIUx.
- **P 1 X**: sleep sensor is connected to pulse input PIx.

The configuration of an analog input is performed.

The configuration of a pulse input is performed.

Depending on the selected source, the process range of the sensor is configured by:

- **[AIx Lowest Process] R 1 X J**, **[AIx Highest Process] R 1 X K** (without unit), when connected on an analog input.
- **[AIv1 Lowest Process] R V 1 J**, **[AIv1 Highest Process] R V 1 K** (without unit), when using the virtual analog input.
- **[DIx PulseInput Low Freq] P 1 L X**, **[DIx PulseInput High Freq] P 1 H X** (without unit), when connected on a pulse input configured in frequency.

[Sleep menu] *5 L P - Menu*

Access

[Complete settings] → [Pump functions] → [Sleep/Wakeup] → [Sleep menu]

About This Menu

[Sleep Detect Mode] *5 L P Π*

Sleep detection mode.

Setting	Code / Value	Description
[No]	<i>n o</i>	Not configured Factory setting
[Switch]	<i>5 w</i>	System enters in sleep mode on switch condition
[Flow]	<i>L f</i>	System enters in sleep mode on low flow condition
[Speed]	<i>5 P d</i>	System enters in sleep mode on speed condition
[Power]	<i>P w r</i>	System enters in sleep mode on power condition
[Pressure]	<i>H P</i>	System enters in sleep mode on high-pressure condition
[Multiple]	<i>o r</i>	System enters in sleep mode on multiple-OR condition

[Sleep Switch Assign] *5 L P w*

Sleep switch assignment.

This parameter can be accessed if [Sleep Detect Mode] *5 L P Π* is set to [Switch] *5 w* or [Multiple] *o r*.

Select an external condition to enter in sleep mode (for example, flow switch).

Setting	Code / Value	Description
[Not Assigned]	<i>n o</i>	Not assigned Factory setting
[DI1]...[DI6]	<i>L , 1...L , 6</i>	Digital input DI1...DI6
[DI11]...[DI16]	<i>L , 11... L , 16</i>	Digital input DI11...DI16 if VW3A3203 I/O extension module has been inserted
[CD00]... [CD10]	<i>C d 0 0... C d 1 0</i>	Virtual digital input CMD.0...CMD.10 in [I/O profile] , <i>o</i> configuration
[CD11]... [CD15]	<i>C d 1 1... C d 1 5</i>	Virtual digital input CMD.11...CMD.15 regardless of configuration
[C101]... [C110]	<i>C 1 0 1... C 1 1 0</i>	Virtual digital input CMD1.01...CMD1.10 with integrated Modbus Serial in [I/O profile] , <i>o</i> configuration
[C111]... [C115]	<i>C 1 1 1... C 1 1 5</i>	Virtual digital input CMD1.11...CMD1.15 with integrated Modbus Serial regardless of configuration
[C201]... [C210]	<i>C 2 0 1... C 2 1 0</i>	Virtual digital input CMD2.01...CMD2.10 with CANopen® fieldbus module in [I/O profile] , <i>o</i> configuration
[C211]... [C215]	<i>C 2 1 1... C 2 1 5</i>	Virtual digital input CMD2.11...CMD2.15 with CANopen® fieldbus module regardless of configuration
[C301]... [C310]	<i>C 3 0 1... C 3 1 0</i>	Virtual digital input CMD3.01...CMD3.10 with a fieldbus module in [I/O profile] , <i>o</i> configuration

Setting	Code / Value	Description
[C311]... [C315]	C 3 1 1... C 3 1 5	Virtual digital input CMD3.11...CMD3.15 with a fieldbus module regardless of configuration
[C501]... [C510]	C 5 0 1... C 5 1 0	Virtual digital input CMD5.01...CMD5.10 with integrated Ethernet Modbus TCP in [I/O profile] , a configuration
[C511]... [C515]	C 5 1 1... C 5 1 5	Virtual digital input CMD5.11...CMD5.15 with integrated Ethernet Modbus TCP regardless of configuration
[DI1 (Low level)]...[DI6 (Low level)]	L 1 L ... L 6 L	Digital input DI1...DI6 used at low level

[Inst. Flow Assign.] F 5 I R★

Installation flow sensor assignment.

This parameter can be accessed if [Sleep Detect Mode] S L P F is set to [Flow] L F , or [Multiple] m r .

Setting	Code / Value	Description
[Not Configured]	n o	Not assigned Factory setting
[AI1]...[AI3]	A 1 , 1...A 1 , 3	Analog input AI1...AI3
[AI4]...[AI5]	A 1 , 4...A 1 , 5	Analog input AI4...AI5 if VW3A3203 I/O extension module has been inserted
[AI Virtual 1]... [AI Virtual 3]	A 1 , V 1... A 1 , V 3	Virtual analogic input 1...3
[DI5 PulseInput Assignment]...[DI6 PulseInput Assignment]	P 1 , 5...P 1 , 6	Digital input DI5...DI6 used as pulse input
[Est. Pump Flow]	S L P F	Sensor less estimated flow
[Est. System Flow]	S L S F	Estimated system flow This selection is only possible if [Pump System Archit] P P S A is set to [Multi Drives] m V S d or [Multi Masters] m V S d r NOTE: To use this selection, all the pump characteristics of the system must be configured.
NOTE: For sensor configuration, refer to section [Sensors assignment].		

[Sleep menu] 5 L P - Menu

Access

[Complete settings] → [Pump functions] → [Sleep/wakeup] → [Sleep menu]

[Sleep Flow Level] 5 L n L ★

Sleep flow level.

Sensor level under which the system should enter the sleep mode (Zero value to deactivate).

This parameter can be accessed if:

- [Inst. Flow Assign.] F 5 I A is not set to [Not Configured] n o , and
- [Sleep Detect Mode] 5 L P n is set to
 - [Flow] L F , or
 - [Multiple] o r .

Setting ()	Description
[No] n o to 32,767	Setting range Unit: [Flow rate unit] 5 u F r (for example, %, l/s; m3/h) Factory setting: [No] n o

[OutletPres Assign] P 5 2 A ★

Outlet pressure sensor assignment.

This parameter can be accessed if:

- [Sleep Detect Mode] 5 L P n is set to [Pressure] H P , or
- [Sleep Detect Mode] 5 L P n is set to [Multiple] o r .

Setting	Code / Value	Description
[Not Configured]	n o	Not assigned Factory setting
[AI1]...[AI3]	A , 1...A , 3	Analog input AI1...AI3
[AI4]...[AI5]	A , 4...A , 5	Analog input AI4...AI5 if VW3A3203 I/O extension module has been inserted
[AI Virtual 1]... [AI Virtual 3]	A , V 1... A , V 3	Virtual analogic input 1...3
NOTE: For sensor configuration, refer to section [Sensors assignment] , page 200.		

[Sleep menu] 5 L P - Menu

Access

[Complete settings] → [Pump functions] → [Sleep/wakeup] → [Sleep menu]

[Sleep Pressure Level] 5 L P L

Sleep pressure level.

This parameter can be accessed if:

- [OutletPres Assign] P 5 2 A is not set to [Not Configured] n o , and
- [Sleep Detect Mode] 5 L P Π is set to
 - [Pressure] H P , or
 - [Multiple] o r .

Setting ()	Description
[No] n o to 32,767	Setting range Unit: [Flow rate unit] 5 u F r (for example, %, l/s; m ³ /h) Factory setting: [No] n o

[Sleep Min Speed] 5 L 5 L ★

Sleep flow level.

Speed level under which the system should enter the sleep mode.

This parameter can be accessed if:

- [Sleep Detect Mode] 5 L P Π is set to [Speed] 5 P d , or
- [Sleep Detect Mode] 5 L P Π is set to [Multiple] o r .

NOTE: To set this parameter, each [Low Speed] L 5 P values of all drives of a multipump architecture needs to be taken into account.

Setting ()	Description
0...500.0 Hz	Setting range Factory setting: [No] n o

[Sleep Power Level] 5 L P r ★

Sleep power level.

Power level under which the system should enter the sleep mode.

This parameter can be accessed if:

- [Sleep Detect Mode] 5 L P Π is set to [Power] P W r , or
- [Sleep Detect Mode] 5 L P Π is set to [Multiple] o r .

Setting ()	Description
0...[Nominal Motor Power] n P r	Setting range Factory setting: [No] n o

[Sleep Delay] *S L P d*★

Sleep delay.

This parameter can be accessed if **[Sleep Detect Mode]** *S L P n* is not set to **[Not Configured]** *n o*.

Setting ()	Description
0...3,600 s	Setting range Factory setting: 20 s

[Boost] 5 5 5 - Menu

Access

[Complete settings] → [Pump functions] → [Sleep/wakeup] → [Sleep menu] → [Boost]

About This Menu

Following parameters can be accessed if [Sleep Detect Mode] 5 5 5 5 is not set to [No] n o.

[Sleep Boost Speed] 5 5 5 5★

Sleep boost speed.

Setting ()	Description
0...599.0 Hz	Setting range Factory setting: n o

[Sleep Boost Time] 5 5 5 5★

Sleep boost time.

Setting ()	Description
0...3,600 s	Setting range Factory setting: n o

[Advanced sleep check] P d 5 - Menu

Access

[Complete settings] → [Pump functions] → [Sleep/wakeup] → [Sleep menu] → [Advanced sleep check]

About This Menu

This function can be activated if [Sleep Detect Mode] 5 L P Π is not set to [No] n o .

This function can be activated if:

- [Type of control] 5 o C 5 is set to [Pressure] P r E 5 5 and,
- [Sleep Detect Mode] 5 L P Π is not set to [No] n o .

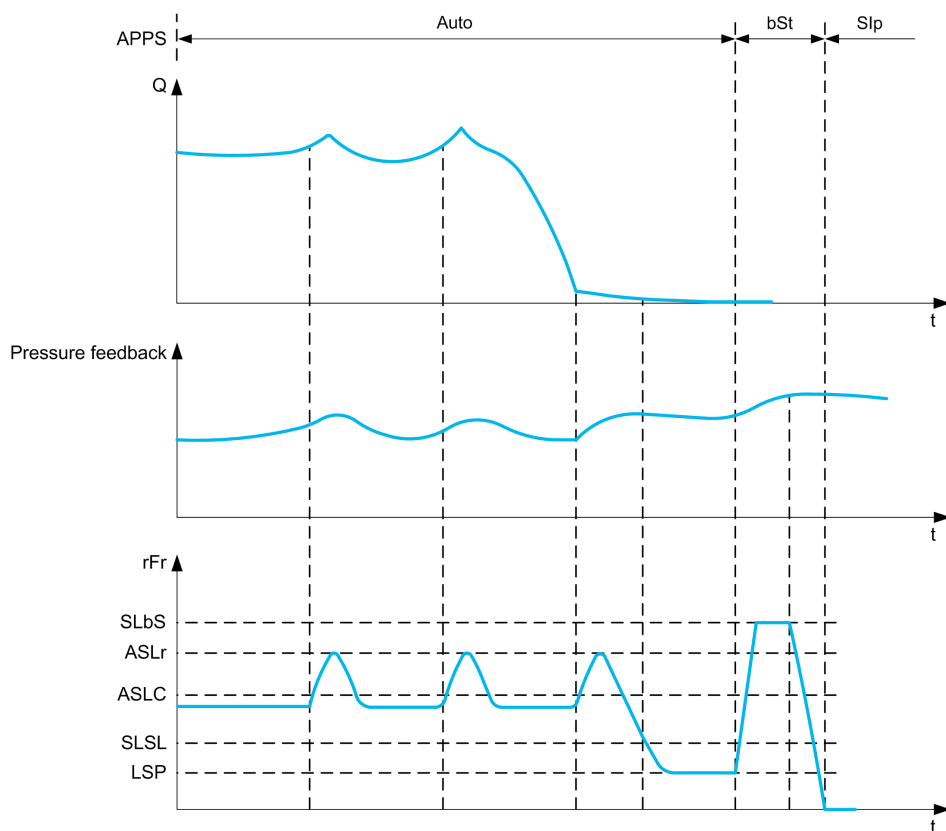

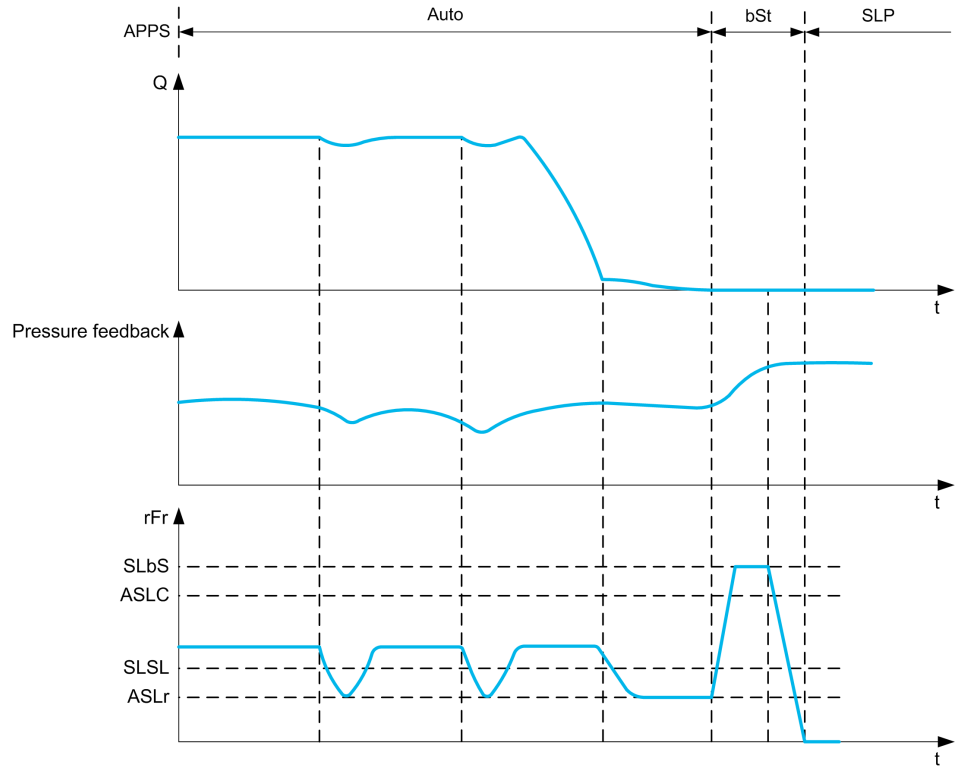

[Sleep Mode] A 5 L Π

Advanced sleep mode.

Setting ()	Code / Value	Description
[No]	n o	No Factory setting
[YES]	y e s	Yes

[Sleep Condition] A 5 L C ★

Advanced sleep verifies speed condition.

This parameter can be accessed if [Sleep Mode] A 5 L Π is not set to [No] n o .

Setting ()	Description
0...[High Speed] H 5 P	Setting range Factory setting: 0.0 Hz

[Sleep Delay] A 5 L d ★

Advanced sleep verifies delay.

This parameter can be accessed if [Sleep Mode] A 5 L Π is not set to [No] n o .

Setting ()	Description
0...9,999 s	Setting range Factory setting: 20 s

[Check Sleep Ref Spd] *A S L r* ★

Advanced sleep verifies speed reference.

This parameter can be accessed if **[Sleep Mode]** *A S L n* is not set to **[No]** *n o*.

Setting 	Description
0... [High Speed] <i>H S P</i>	Setting range Factory setting: 0.0 Hz

[Wake up menu] WK P - Menu

Access

[Complete settings] → [Pump functions] → [Sleep/wakeup] → [Wake up menu]

About This Menu

This menu can be accessed if [Sleep Detect Mode] 5 L P Π is not set to [Not Configured] n o .

[Wake Up Mode] W U P Π★

Wake-up mode.

Setting	Code / Value	Description
[Feedback]	F b K	Wake-up on PID feedback level Factory setting
[Error]	E r r	Wake-up on PID error level
[Pressure]	L P	Wake-up on low-pressure condition

[Wake Up Process Level] W U P F★

Wake-up process value level.

This parameter can be accessed if [Wake Up Mode] W U P Π is set to [Feedback] F b K .

Setting ()	Description
[Min PID feedback] P , F 1... [Max PID feedback] P , F 2	Setting range Factory setting: 0

[Wake Up Process Error] W U P E★

Wake-up process value error level.

This parameter can be accessed if [Wake Up Mode] W U P Π is set to [Error] E r r .

Setting ()	Description
0...[Max PID feedback] P , F 2	Setting range Factory setting: 0,0 Hz

[OutletPres Assign] P 5 2 A★

Outlet pressure sensor assignment.

This parameter can be accessed if [Wake Up Mode] W U P Π is set to [Pressure] L P .

Setting	Code / Value	Description
[Not Configured]	<i>na</i>	Not assigned Factory setting
[AI1]...[AI3]	<i>R , 1...R , 3</i>	Analog input AI1...AI3
[AI4]...[AI5]	<i>R , 4...R , 5</i>	Analog input AI4...AI5 if VW3A3203 I/O extension module has been inserted
[AI Virtual 1]... [AI Virtual 3]	<i>R , V 1... R , V 3</i>	Virtual analogic input 1...3
NOTE: For sensor configuration, refer to section [Sensors assignment] , page 200.		

[Wake Up Press Level] *WUP L* ★

Wake-up pressure level.

Pressure level over which the system should leave the sleep mode.

This parameter can be accessed if **[Wake Up Mode] *WUP M*** is set to **[Pressure] *LP***.

Setting ()	Description
[No] <i>na</i> to 32,767	Setting range Unit: [P sensor unit] <i>SUP r</i> (for example, Pa, Bar, PSI, %) Factory setting: [No] <i>na</i>

[Wake up menu] WK P - Menu

Access

[Complete settings] → [Pump functions] → [Sleep/wakeup] → [Wake up menu]

About This Menu

This menu can be accessed if [Sleep Detect Mode] Ⓛ Ⓜ Ⓟ is not set to [Not Configured] Ⓛ Ⓜ.

[Wake Up Press Level] W U P L ★

Wake-up pressure level.

Pressure level over which the system should leave the sleep mode.

This parameter can be accessed if [Wake Up Mode] W U P Ⓟ is set to [Pressure] Ⓛ Ⓜ.

Setting Ⓛ	Description
[No] Ⓛ Ⓜ to 32,767	Setting range Unit: [P sensor unit] Ⓛ Ⓜ Ⓟ (for example, Pa, Bar, PSI, %) Factory setting: [No] Ⓛ Ⓜ

[Wake Up Delay] W U P D ★

Wake-up delay.

Setting Ⓛ	Description
0...3,600 s	Setting range Factory setting: 0 s

[Pump functions] - [Feedback monitoring]

[Feedback monitoring] $P F \Pi$ - Menu

Access

[Complete settings] \rightarrow [Pump functions] \rightarrow [Feedback monitoring]

About This Menu

The function is typically used to detect cases where the installation capability is exceeded or where the installation is not operating properly:

- Fire hydrant opened.
- Pump start-up with open discharge valve.
- Mechanical breakdown of pipes.
- Water leakage.

When the drive is running at high speed, this function monitors the PID feedback in order to detect if it is out of a given range around the setpoint during a configurable time.

By using a warning or a detected error, this function also indicates that:

- The capability of the installation is exceeded
- The proper control could not be ensured
- Something is wrong on the installation.

This menu can be accessed if [PID feedback Assign] P , F is not set to [Not Configured] $\Pi \Pi$.

This graphic presents the PID feedback monitoring:

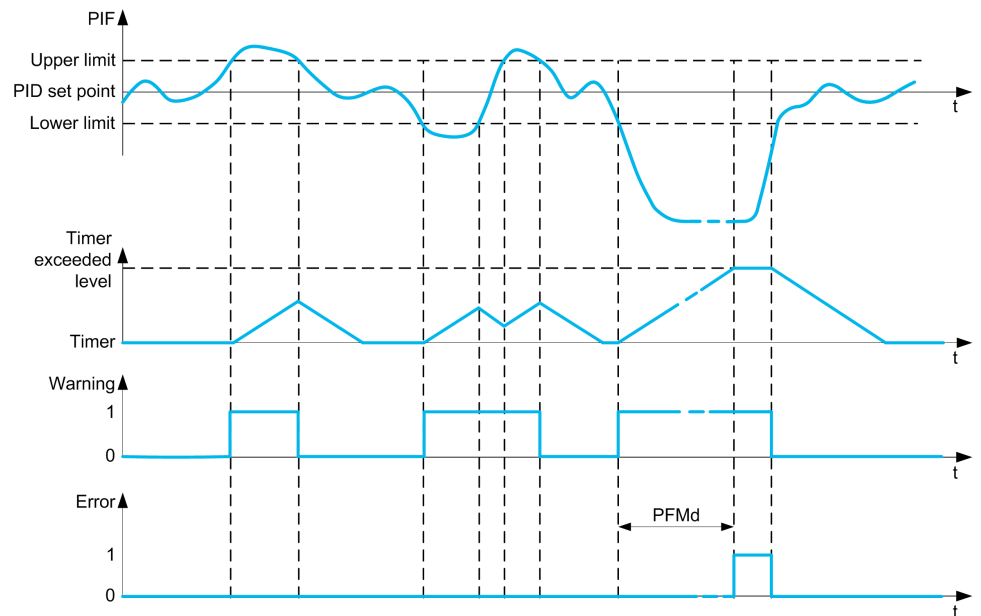

[PID Fdbk Monitoring] $P F \Pi \Pi$

PID feedback monitoring mode.

Parameter used to activate the function.

Setting	Code / Value	Description
[No]	n o	No Factory setting
[Yes]	y e s	Yes

[PID Fdbk Range] P F Π r ★

PID feedback monitoring range.

Range within which the PID feedback value is supposed to stay in normal situation.

This parameter can be accessed if **[PID Fdbk Monitoring] P F Π Π** is not set to **[No] n o**.

Setting (C)	Description
0...100%	Setting range Factory setting: 3%

[PID Fdbk Error Delay] P F Π d ★

PID feedback monitoring delay.

Delay to trig an error after detection of an anomaly.

This parameter can be accessed if **[PID Fdbk Monitoring] P F Π Π** is not set to **[No] n o**.

Setting (C)	Description
0...3,600 s	Setting range Factory setting: 10 s

[PID Fdbk Error Resp] P F Π b ★

PID feedback monitoring response to a detected error.

Define how the drive reacts when a feedback monitoring error occurs.

This parameter can be accessed if **[PID Fdbk Monitoring] P F Π Π** is not set to **[No] n o**.

Setting	Code / Value	Description
[Ignore]	n o	Detected error ignored
[Freewheel Stop]	y e s	Freewheel stop
[Per STT]	s t t	Stop according to [Type of stop] s t t parameter but without an error triggered after stop
[Fallback Speed]	l f f	Change to fallback speed, maintained as long as the detected error persists and the command has not been removed ⁽¹⁾
[Ramp stop]	r Π P	Stop on ramp Factory setting

[Pump functions] - [Pump characteristics]

[Pump characteristics] $P \llcorner r$ - Menu

Access

[Complete settings] \rightarrow [Pump functions] \rightarrow [Pump characteristics]

About This Menu

Centrifugal pump characteristic allows you to define the curve points for:

- Head
- Mechanical power
- Efficiency

The pump manufacture supplies these elements and it is necessary to define the performances of a pump at a given speed.

Pump data is characterized in several points and for a given speed (typically nominal speed):

- Speed (N) used for characterization: typically nominal speed.
- Flow (Q) on each characteristic point.
- Head (H) on each characteristic point.
- Power (P) on each characteristic point.

Example for simplified pump data curves:

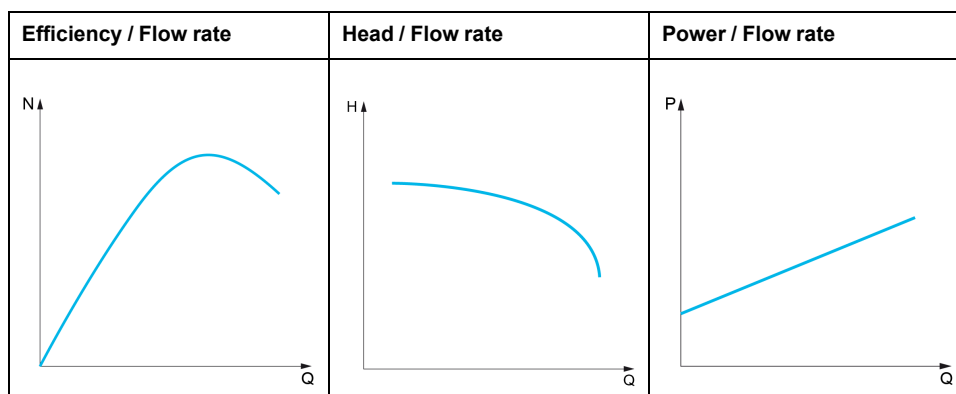

This function allows to:

- interpolate the curves at a given speed, thus minimizing interpolation errors,
- interpolate the curves for other pump speeds using affinity motor control types.

Use-case

Several functions need [HQ] $H \varphi$ or [PQ] $P \varphi$ curves before being used.

Monitoring of pump working point on pump curve:

Use-case	Characterized Pump Data (vs. pump speed)	
	HQ	PQ
"Head vs Flow" curve	X	
"Power vs Flow" curve		X
"Power vs Speed" (fixed Q values)		X

Sensorless flow estimation:

Use-case	Characterized Pump Data (vs. pump speed)	
	HQ	PQ
Estimation of flow from head	X	
Estimation of flow from power		X

Function Activation

To activate this function, set [Mode] P C Π to [HQ] H η or [PQ] P η or [PHQ] P H η . It depends on the data you enter.

After entering all the data (curve + BEP), set [Pump Curve Activate] P C R to [YES] Y E 5.

Curve Setting

The entering points should be spaced as evenly as possible over the operating range for the given speed:

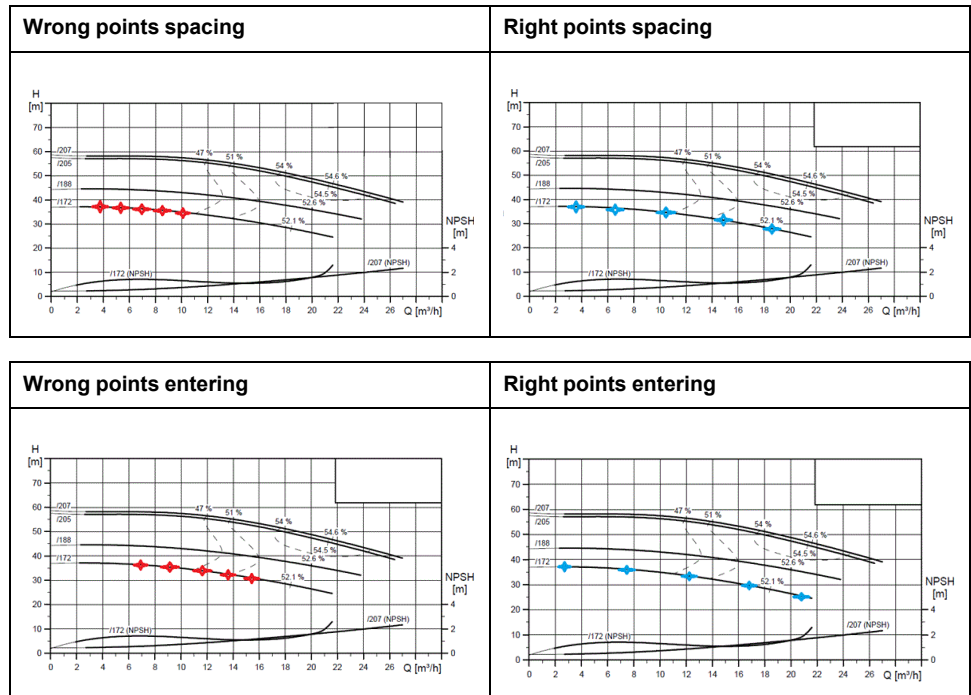

For [HQ] H η or [PQ] P η curves, 5 points are advised:

- Q1 near the low or zero flow point.
- Q3 near the BEP point.
- Q5 near the zero head point.
- Q2 equidistant between Q1 and Q3.
- Q4 equidistant between Q3 and Q5.

Configuration of Best Efficiency Point (BEP)

The configuration of BEP allows you to display this on H η , P η and E η curve:

- Pump curve flow rate at BEP: [Flow at BEP] P C b η .
- Pump curve head at BEP: [Head BEP] P C b H.
- Pump curve power at BEP: [Power BEP] P C b P.

This graphic represents the curve and the BEP:

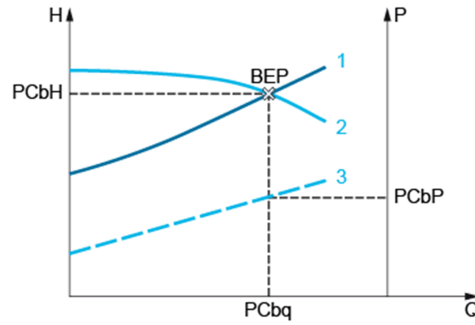

- 1 System curve
- 2 Pump H Q curve
- 3 Pump P Q curve

[Mode] $P \llcorner \Pi$

Pump curve mode.

Select which curve data are managed and is entered on.

Setting	Code / Value	Description
[No]	$n o$	Function is not activated Factory setting
[HQ]	$H Q$	H, Q data is activated
[PQ]	$P Q$	P, Q data is activated
[PHQ]	$P H Q$	P, H, Q data is activated

[Pump Curve Activate] $P \llcorner A \star$

Pump curve activation.

Parameter used to reset or validate data to be used by other functions.

This parameter can be accessed if [Mode] $P \llcorner \Pi$ is not set to [No] $n o$.

Setting	Code / Value	Description
[No]	$n o$	Pump characteristics are deactivated and data can be modified Factory setting
[YES]	$Y E S$	Ask for pump characteristic activation. If it does not succeed, write back NO; else lock data modification

[Status] $P \llcorner S \star$

Pump curve status.

This parameter can be accessed if [Mode] $P \llcorner \Pi$ is not set to [No] $n o$.

Setting	Code / Value	Description
[None]	$n o n e$	Function is not configured Factory setting
[Inactive]	$n A C T$	Function is configured but inactive (data is unlocked)

Setting	Code / Value	Description
[Active]	<i>A C T I V E</i>	Data is activated and can be used for other functions (data is locked)
[Failed]	<i>F A I L E d</i>	Data activation does not succeed (some points have not been entered or data entered does not comply with the rules)

[Pump Liquid Density] *r H o C* ★

Liquid density used to characterize pump.

This parameter can be accessed if [Mode] *P C Π* is not set to [No] *n o*.

Setting 	Description
100...10,000 kg/m ³	Setting range Factory setting: 1000 kg/m ³

[Pump Speed] *P C S P* ★

Pump speed for which curves are entered.

This parameter can be accessed if [Mode] *P C Π* is not set to [No] *n o*.

Setting	Description
0...32,767 rpm	Setting range Factory setting: 0 rpm

[Flow at BEP] *P C b q* ★

Pump curve flow rate at BEP.

This parameter can be accessed if [Mode] *P C Π* is not set to [No] *n o*.

Setting 	Description
0...32,767	Setting range according to [Flow rate unit] <i>S u F r</i> Factory setting: 0

[Head BEP] *P C b H* ★

Pump curve head at BEP.

This parameter can be accessed if [Mode] *P C Π* is not set to [No] *n o*.

Setting 	Description
0...32,767	Setting range according to [P sensor unit] <i>S u P r</i> Factory setting: 0

[Power BEP] *P C b P* ★

Pump curve power at BEP.

This parameter can be accessed if [Mode] *P C Π* is not set to [No] *n o*.

Setting 	Description
0...32,767	Setting range according to [Motor Standard] b F r Factory setting: 0

[Flow 1] P C 9 I ★

Pump curve flow rate for point 1.

Flow rate entered at point 1 (for HQ and PQ curves).

This parameter can be accessed if **[Mode]** P C 11 is not set to **[No]** n o .

Setting 	Description
0...32,767	Setting range according to [Flow rate unit] S u F r Factory setting: 0

[Head 1] P C H I ★

Pump curve head for point 1.

Head entered at point 1 (for HQ curve).

This parameter can be accessed if **[Mode]** P C 11 is set to **[HQ]** H 9 or **[PHQ]** P H 9 .

Setting 	Description
0...32,767	Setting range according to [P sensor unit] S u P r Factory setting: 0

[Power 1] P C P I ★

Pump curve power for point 1.

Mechanical power entered at point 1 (for PQ curve).

This parameter can be accessed if **[Mode]** P C 11 is set to **[PQ]** P 9 or **[PHQ]** P H 9 .

Setting 	Description
0...32,767	Setting range according to [Motor Standard] b F r Factory setting: 0

[Flow 2] P C 9 2 ★

Pump curve flow rate for point 2.

Flow rate entered at point 2 (for HQ and PQ curves).

This parameter can be accessed if **[Mode]** P C 11 is not set to **[No]** n o .

Setting 	Description
0...32,767	Setting range according to [Flow rate unit] S u F r Factory setting: 0

[Head 2] P C H 2★

Pump curve head for point 2.

Head entered at point 2 (for HQ curve).

Setting 	Description
0...32,767	Setting range according to [P sensor unit] S u P r Factory setting: 0

[Power 2] P C P 2★

Pump curve power for point 2.

Mechanical power entered at point 2 (for PQ curve).

This parameter can be accessed if **[Mode] P C Π** is set to **[PQ] P 9** or **[PHQ] P H 9**.

Setting 	Description
0...32,767	Setting range according to [Motor Standard] b F r Factory setting: 0

[Flow 3] P C 9 3★

Pump curve flow rate for point 3.

Flow rate entered at point 3 (for HQ and PQ curves).

This parameter can be accessed if **[Mode] P C Π** is not set to **[No] n o**.

Setting 	Description
0...32,767	Setting range according to [Flow rate unit] S u F r Factory setting: 0

[Head 3] P C H 3★

Pump curve head for point 3.

Head entered at point 3 (for HQ curve).

This parameter can be accessed if **[Mode] P C Π** is set to **[HQ] H 9** or **[PHQ] P H 9**.

Setting 	Description
0...32,767	Setting range according to [P sensor unit] S u P r Factory setting: 0

[Power 3] P C P 3★

Pump curve power for point 3.

Mechanical power entered at point 3 (for PQ curve).

This parameter can be accessed if [Mode] P C Π is set to [PQ] P 9 or [PHQ] P H 9.

Setting 	Description
0...32,767	Setting range according to [Motor Standard] b F r Factory setting: 0

[Flow 4] P C 9 4★

Pump curve flow rate for point 4.

Flow rate entered at point 4 (for HQ and PQ curves).

This parameter can be accessed if [Mode] P C Π is not set to [No] n o.

Setting 	Description
0...32,767	Setting range according to [Flow rate unit] S u F r Factory setting: 0

[Head 4] P C H 4★

Pump curve head for point 4.

Head entered at point 4 (for HQ curve).

This parameter can be accessed if [Mode] P C Π is set to [HQ] H 9 or [PHQ] P H 9.

Setting 	Description
0...32,767	Setting range according to [P sensor unit] S u P r Factory setting: 0

[Power 4] P C P 4★

Pump curve power for point 4.

Mechanical power entered at point 4 (for PQ curve).

This parameter can be accessed if [Mode] P C Π is set to [PQ] P 9 or [PHQ] P H 9.

Setting 	Description
0...32,767	Setting range according to [Motor Standard] b F r Factory setting: 0

[Flow 5] P C 9 5★

Pump curve flow rate for point 5.

Flow rate entered at point 5 (for HQ and PQ curves).

This parameter can be accessed if [Mode] P C Π is not set to [No] n o.

Setting 	Description
0...32,767	Setting range according to [Flow rate unit] <i>S u F r</i> Factory setting: 0

[Head 5] *PC H 5* ★

Pump curve head for point 5.

Head entered at point 5 (for HQ curve).

This parameter can be accessed if **[Mode]** *PC Π* is set to **[HQ]** *H 9* or **[PHQ]** *PH 9*.

Setting 	Description
0...32,767	Setting range according to [P sensor unit] <i>S u P r</i> Factory setting: 0

[Power 5] *PC P 5* ★

Pump curve power for point 5.

Mechanical power entered at point 5 (for PQ curve).

This parameter can be accessed if **[Mode]** *PC Π* is set to **[PQ]** *P 9* or **[PHQ]** *PH 9*.

Setting 	Description
0...32,767	Setting range according to [Motor Standard] <i>b F r</i> Factory setting: 0

[Pump Op Point Filter] *WP X F* ★

Pump operating point filter.

This parameter can be accessed if **[Mode]** *PC Π* is not set to **[No]** *no*.

Setting 	Description
0.00 s...60.00 s	Setting range Factory setting: 1.00 s

[Pump functions] - [Sensorless flow estimation]

[Flow estimation] $\bar{5} \bar{F} \bar{E}$ - Menu

Access

[Complete settings] → [Pump functions] → [Flow estimation]

About This Menu

This menu can be accessed if [Mode] $\bar{P} \bar{L} \bar{\Pi}$ is not set to [No] $\bar{n} \bar{o}$, page 347.

This function allows the estimation of the flow of the pump using the predefined pump curves HQ or PQ set in the pump characteristics.

The PQ curve shall be used if there is no pressure sensor on the system.

The HQ curve shall be used if inlet and/or outlet pressure feedbacks are available (or a differential value).

The curves shall be set in the pump characteristic functions before setting the sensorless flow estimation function.

The figure below shows the calculating area (1) using the HQ curve.

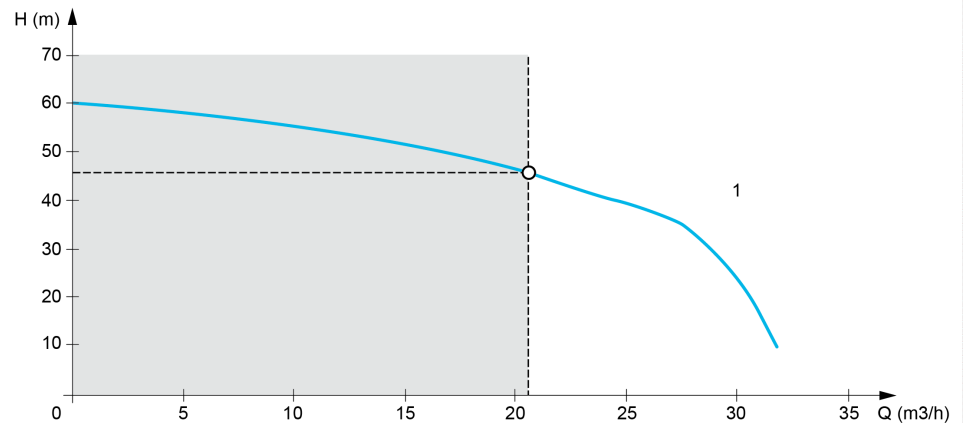

The figure below shows the calculating area (2) using the PQ curve.

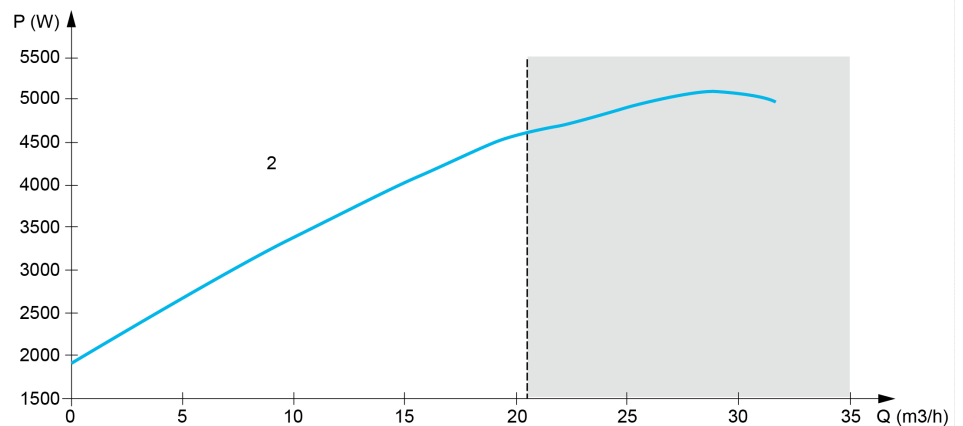

Using the PQ curve, it is necessary to calibrate the function with:

- **[Power Dynamic Gain] $\bar{P} \bar{E} \bar{G}$** to define a correction gain applied to the estimated power from the drive
- **[Power Static Offset] $\bar{P} \bar{E} \bar{o}$** to define a correction offset applied to the estimated power from the drive

- **[Liquid Density]** $r H \rho$ is the density of the fluid to be pumped

Using the HQ curve, it is necessary to enter the data related to the application:

- **[Liquid Density]** $r H \rho$ is the density of the fluid to be pumped
- **[Head Dynamic Gain]** $H E G$ is the correction gain, modeling the dynamical head losses between the two pressure sensors
- **[Head Static Offset]** $H E \rho$ is a correction offset applied to the head provided by the pump

[Flow Estimation Mode] $F E \Pi$

Flow estimation mode.

Setting	Code / Value	Description
[No]	$n \rho$	Function not activated Factory setting
[HQ]	$H \varphi$	H, Q data is activated
[PQ]	$P \varphi$	P, Q data is activated

[Head Dynamic Gain] $H E G \star$

Head dynamic gain.

This parameter can be accessed if **[Flow Estimation Mode]** $F E \Pi$ is set to **[HQ]** $H \varphi$.

Setting 	Description
-100.0...100.0%	Setting range Factory setting: 0.0%

[Head Static Offset] $H E \rho \star$

Head static offset.

This parameter can be accessed if **[Flow Estimation Mode]** $F E \Pi$ is set to **[HQ]** $H \varphi$.

Setting 	Description
-100.0...100.0%	Setting range Factory setting: 0.0%

[Power Dynamic Gain] $P E G \star$

Power dynamic gain.

This parameter can be accessed if **[Flow Estimation Mode]** $F E \Pi$ is set to **[PQ]** $P \varphi$.

Setting 	Description
-100.0...100.0%	Setting range Factory setting: 0.0%

[Power Static Offset] *PEO*★

Power static offset.

This parameter can be accessed if **[Flow Estimation Mode] *FEN*** is set to **[PQ] *PQ***.

Setting 	Description
-100.0...100.0%	Setting range Factory setting: 0.0%

[Pump Flow] *F52U*

Pump flow sensor value.

Setting 	Description
-32,767...32,767	Setting range Factory setting: -

[Flow Estimated] *SLFU*★

Estimated flow value.

This parameter can be accessed if **[Flow Estimation Mode] *FEN*** is not set to **[No] *NO***

Setting 	Description
Value in application customer unit	Setting range Factory setting: -

[Pump functions] - [dP/Head Correction]

[dP/Head Correction] d P H C - Menu

Access

[Complete settings] → [Pump functions] → [dP/Head Correction]

This menu can be accessed if:

- [Mode] P C Π is set to [HQ] H φ or [PHQ] P H φ and,
- [OutletPres Assign] P S ϱ R is not set to [Not Configured] n σ .

About This Menu

This function allows adjustment of the estimated delta pressure and the pump head using the predefined pump curves HQ or PHQ set in the pump characteristics and the outlet pressure sensor assigned.

The curves shall be set in the pump characteristics functions before setting the function

[Head Dynamic Gain] H E G ★

Head dynamic gain.

This parameter can be accessed if [Flow Estimation Mode] F E Π is set to [HQ] H φ .

Setting (°)	Description
-100.0...100.0%	Setting range Factory setting: 0.0%

[Head Static Offset] H E σ ★

Head static offset.

This parameter can be accessed if [Flow Estimation Mode] F E Π is set to [HQ] H φ .

Setting (°)	Description
-100.0...100.0%	Setting range Factory setting: 0.0%

[Est. Pump dP] S L d P ★

Estimated Pump delta pressure value

This parameter can be accessed if [OutletPres Assign] P S ϱ R is not set to [Not Configured] n σ .

Setting	Description
-32,767...32,767	Setting range according to [P sensor unit] S μ P r Factory setting: –

[Est. Pump Head] *U L H V* ★

Estimated Pump head value

This parameter can be accessed if **[OutletPres Assign]** *P S Z R* is not set to **[Not Configured]** *n o*.

Setting	Description
-32,767...32,767	Setting range according to [P sensor unit] <i>S u P r</i> Factory setting: –

[Pump functions] - [Pump start stop]

[Pump start stop] $P \mathcal{S} \mathcal{L} -$ Menu

Access

[Complete settings] → [Pump functions] → [Pump start stop]

About This Menu

This function defines how the acceleration and deceleration are controlled during start and stop of the pump.

The pump working area is within the speed range [Low Speed] $L \mathcal{S} P$ - [High Speed] $H \mathcal{S} P$.

The minimum speed is provided by the pump manufacturer according to the application.

Running below the minimum speed and/or starting the pump with a long acceleration ramp time has an impact on the lubrication of the seal, on the cooling of the impeller and the bearings.

A specific check-valve deceleration ramp is available to reduce any large variation of pressure that can generate an instability of the valve.

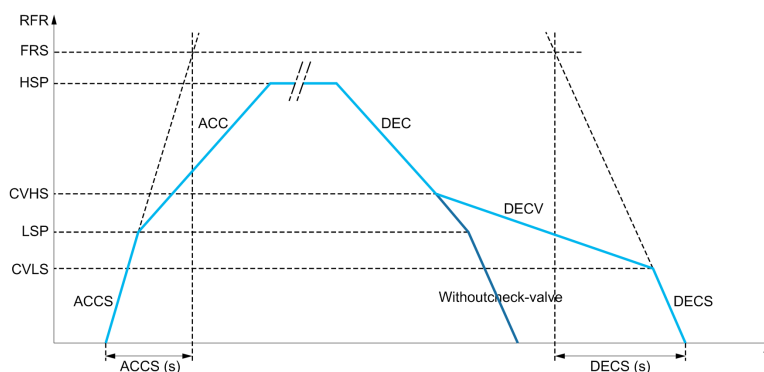

When the pump starts, the pump accelerates up to [Low Speed] $L \mathcal{S} P$ according to [Start Accel Ramp] $R \mathcal{L} \mathcal{L} \mathcal{S}$. When the pump speed is above [Low Speed] $L \mathcal{S} P$, the pump acceleration and deceleration are managed according to [Acceleration] $R \mathcal{L} \mathcal{L}$ and [Deceleration] $d \mathcal{E} \mathcal{L}$ if no other function is activated.

When the pump stops:

- The pump decelerates down to [Check Valve Spd 2] $\mathcal{L} \mathcal{V} \mathcal{H} \mathcal{S}$ according to [Deceleration] $d \mathcal{E} \mathcal{L}$
- The pump decelerates from [Check Valve Spd 2] $\mathcal{L} \mathcal{V} \mathcal{H} \mathcal{S}$ to [Check Valve Spd 1] $\mathcal{L} \mathcal{V} \mathcal{L} \mathcal{S}$ according to [Dec. Check Valve] $d \mathcal{E} \mathcal{L} \mathcal{V}$
- The pump decelerates from [Check Valve Spd 1] $\mathcal{L} \mathcal{V} \mathcal{L} \mathcal{S}$ to zero speed according to [Deceleration on Stop] $d \mathcal{E} \mathcal{L} \mathcal{S}$

If [Start Accel Ramp] $R \mathcal{L} \mathcal{L} \mathcal{S} = 0$, the start ramp is ignored and [Acceleration] $R \mathcal{L} \mathcal{L}$ is used to start the pump.

If [Dec. Check Valve] $d \mathcal{E} \mathcal{L} \mathcal{V} = 0$, the check-valve ramp is ignored and is used to decelerate up to [Low Speed] $L \mathcal{S} P$, then [Deceleration on Stop] $d \mathcal{E} \mathcal{L} \mathcal{S}$ is used (see below).

If [Deceleration on Stop] $d \mathcal{E} \mathcal{L} \mathcal{S} = 0$, the normal deceleration [Deceleration] $d \mathcal{E} \mathcal{L}$ is used to stop the pump.

[Low Speed] *L S P*

Motor frequency at low speed.

Setting ()	Description
0...[High Speed] <i>H S P</i>	Setting range Factory setting: 0 Hz

[High Speed] *H S P*

Motor frequency at high speed.

To help prevent **[Motor Overspeed] *S O F*** error, it is recommended to have **[Max Frequency] *L F r*** equal to or higher than 110% of **[High Speed] *H S P***.

Setting ()	Description
[Low Speed] <i>L S P</i> ...[Max Frequency] <i>L F r</i>	Setting range Factory setting: 50.0 Hz

[Acceleration] *A C C*

Time to accelerate from 0 to the **[Nominal Motor Freq] *F r S***.

To have repeatability in ramps, the value of this parameter must be set according to the possibility of the application.

Setting ()	Description
0.00...6,000.00 s ⁽¹⁾	Setting range Factory setting: 10.00 s
(1) Range 0.00 to 99.99 s or 0.0 to 999.9 s or 0 to 6,000 according to [Ramp increment] <i>i n r</i>	

[Deceleration] *d E C*

Time to decelerate from the **[Nominal Motor Freq] *F r S*** to 0.

To have repeatability in ramps, the value of this parameter must be set according to the possibility of the application.

Setting ()	Description
0.00...6,000.00 s ⁽¹⁾	Setting range Factory setting: 10.00 s
(1) Range 0.00 to 99.99 s or 0.0 to 999.9 s or 0 to 6,000 according to [Ramp increment] <i>i n r</i>	

[Start Accel Ramp] *A C C S*

Acceleration on start.

Setting ()	Description
[No] n o ...6,000 s ⁽¹⁾	Setting range Factory setting: [No] n o
(1) Range 0.00 to 99.99 s or 0.0 to 999.9 s or 0 to 6,000 according to [Ramp increment] i n r	

[Final Dec. Ramp] d E C S

Deceleration on stop.

Setting ()	Description
[No] n o ...6,000 s ⁽¹⁾	Setting range Factory setting: [No] n o
(1) Range 0.00 to 99.99 s or 0.0 to 999.9 s or 0 to 6,000 according to [Ramp increment] i n r	

[Dec. Check Valve] d E C V

Deceleration while check valve is closing (smooth).

Setting ()	Description
[No] n o ...6,000 s ⁽¹⁾	Setting range Factory setting: [No] n o
(1) Range 0.00 to 99.99 s or 0.0 to 999.9 s or 0 to 6,000 according to [Ramp increment] i n r	

[Check Valve Spd 1] C V L S ★

Speed level up to which check valve ramp is used.

This parameter can be accessed if [Dec. Check Valve] d E C V is not set to 0.

Setting ()	Description
0...[Check Valve Spd 2] C V H S	Setting range Factory setting: 0 Hz

[Check Valve Spd 2] C V H S ★

Speed level from which check valve ramp is used.

This parameter can be accessed if [Dec. Check Valve] d E C V is not set to 0.

Setting ()	Description
[Check Valve Spd 1] C V L S ... H S P	Setting range Factory setting: 0 Hz

[Ref Freq Template] b S P

Low speed management (template).

This parameter defines how the speed reference is taken into account, for analog inputs and pulse input only. In the case of the PID controller, this is the PID output reference.

The limits are set by the [Low speed] L 5 P and [High speed] H 5 P parameters

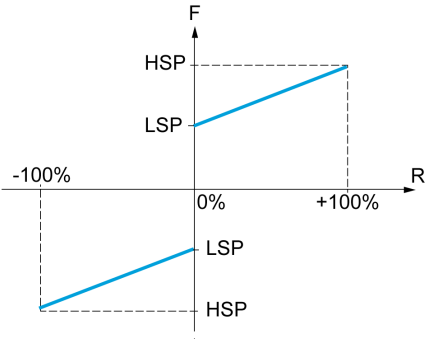
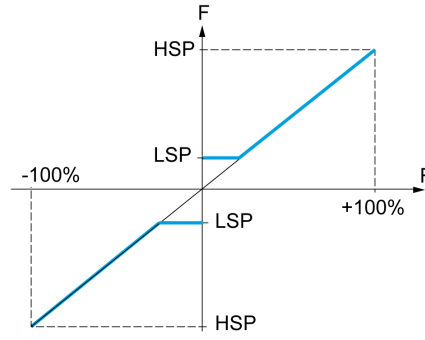
Setting ()	Code / Value	Description
[Standard]	b 5 d	 <p>F Frequency</p> <p>R Reference At zero reference the frequency = LSP</p> <p>Factory setting</p>
[Pedestal]	b L 5	 <p>F Frequency</p> <p>R Reference At reference = 0 to LSP the frequency = LSP</p>

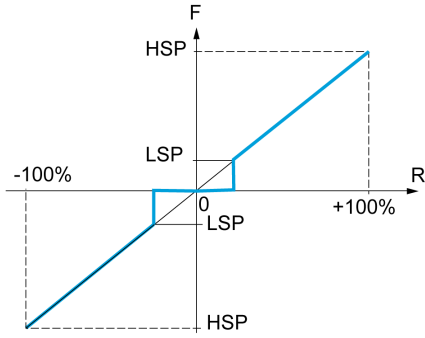
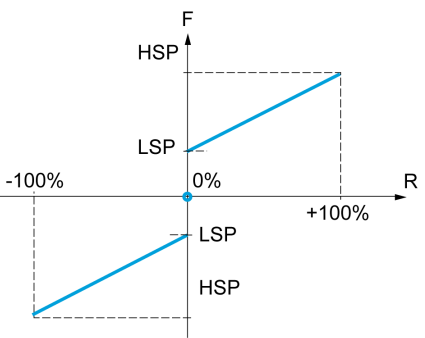
Setting ()	Code / Value	Description
[Deadband]	b n 5	 <p>F Frequency</p> <p>R Reference At reference = 0 to LSP the frequency = 0</p>
[Deadband at 0%]	b n 5 0	 <p>F Frequency</p> <p>R Reference This operation is the same as [Standard] b 5 d, except that in the following cases at zero reference, the frequency = 0: The signal is less than [Min nvalue], which is greater than 0 (example: 1 Vdc on a 2–10 Vdc input) The signal is greater than [Min nvalue], which is greater than [Max value] (example: 11 Vdc on a 10–0 Vdc input).</p> <p>If the input range is configured as “bidirectional”, operation remains identical to [Standard] b 5 d.</p>

[Pump functions] - [Pipe fill]

[Pipe fill] *P F* , - Menu

Access

[Complete settings] → [Pump functions] → [Pipe fill]

About This Menu

This menu can be accessed if **[Application Selection]** *APP L* is not set to **[Pump Level Control]** *LEV L* or **[Generic Fan Control]** *FR n*.

The pipe fill function helps to prevent a water hammer effect from happening in the pipes when a system is filled in too quickly.

The function covers the horizontal pipe applications which are pressure-controlled by the PID function.

The pipe fill function can always be enabled or conditioned by a digital input (or a control bit in the I/O profile).

At the first start command in automatic mode, the system enters the pipe fill mode.

At next start commands, the drive will enter the pipe fill mode if the system pressure feedback is lower than **[Pipe Fill Pressure]** *P F H P*.

Each time the drive wakes-up, the drive enters the pipe fill mode if **[Pipe Fill on Wake Up]** *P F W u* is set to **[Yes]** *Y E S*.

The system remains in the horizontal pipe fill at **[Pipe Fill Speed]** *P F H S* speed until:

- the pressure feedback becomes greater than **[Pipe Fill Pressure]** *P F H P* parameter, or
- the system has been in the pipe fill for longer than **[Pipe Fill Time]** *P F H L* time.

If one of these conditions is met, the system enters the automatic pressure regulation mode.

NOTE: If **[Pipe Fill Time]** *P F H L* is set to 0, the system never enter the Pipe fill mode.

To set up this function, it is recommended to set both **[Pipe Fill Speed]** *P F H S* and **[Pipe Fill Time]** *P F H L* according to the maximum quantity of liquid to fill in the empty system.

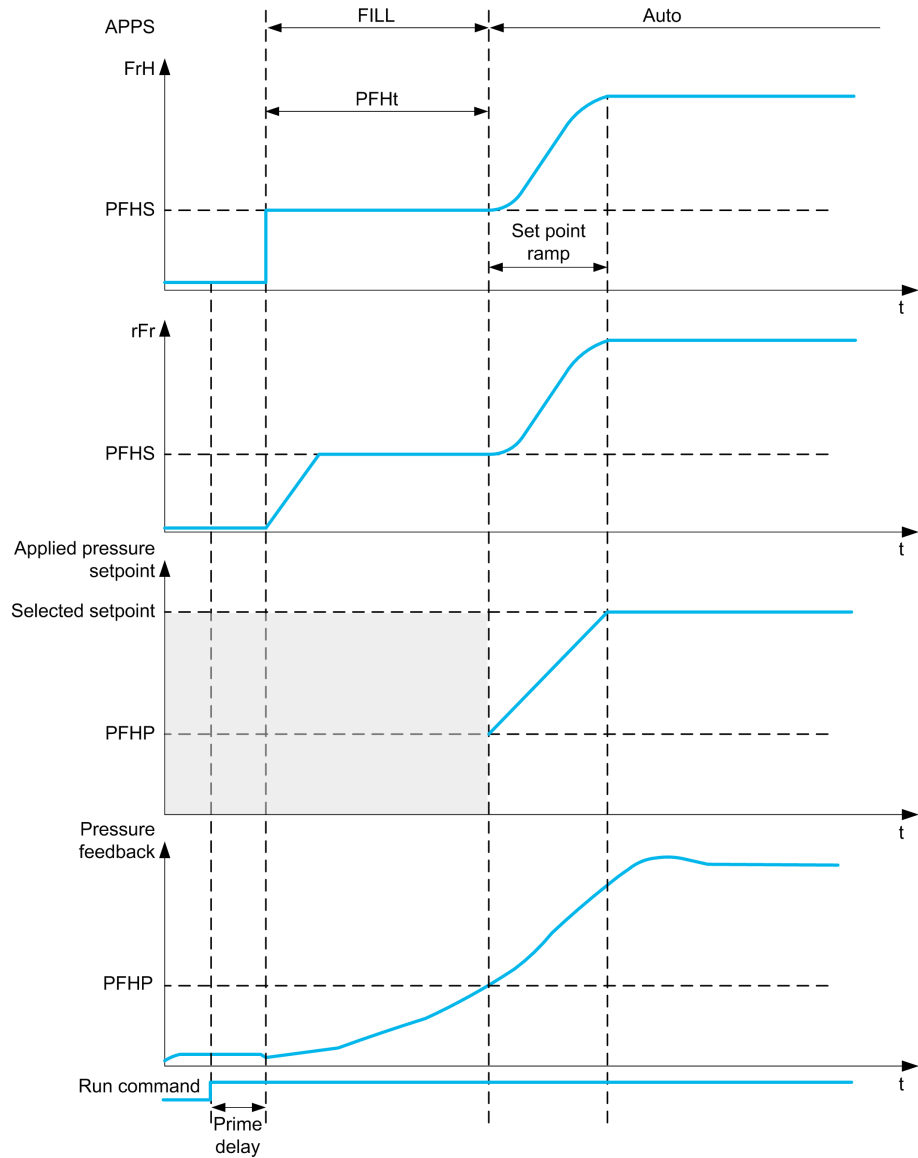

[Activation Mode] P F Π

Pipe fill activation mode.

Setting	Code / Value	Description
[No]	n o	Pipes fill disabled Factory setting
[Feedback]	F b K	Pipe fill on PID feedback This selection can be accessed if [Type of control] E o C k is set to [Pressure] P r E 5 5 and [PID feedback] P , F is not set to [Not Configured] n o.
[Outlet Pressure]	P 5 2	Pipe fill on outlet pressure

[OutletPres Assign] P 5 2 A★

Outlet pressure sensor assignment.

This parameter can be accessed if [Activation Mode] P F Π is set to [Outlet Pressure] P 5 2.

Setting	Code / Value	Description
[Not Configured]	n a	Not assigned Factory setting
[AI1]...[AI3]	R , 1...R , 3	Analog input AI1...AI3
[AI4]...[AI5]	R , 4...R , 5	Analog input AI4...AI5 if VW3A3203 I/O extension module has been inserted
[AI Virtual 1]... [AI Virtual 3]	R , V 1... R , V 3	Virtual analogic input 1...3
NOTE: For sensor configuration, refer to section [Sensors assignment] , page 200.		

[Pipe fill] P F , - Menu

Access

[Complete settings] → [Pump functions] → [Pipe fill]

[Activation Source] P F E c ★

Pipe fill activation source.

This parameter can be accessed if [Activation Mode] P F Π is not set to [No] n o .

Setting	Code / Value	Description
[Not Assigned]	n o	Not assigned Factory setting
[DI1]...[DI6]	L , 1...L , 6	Digital input DI1...DI6
[DI11]...[DI16]	L , 11... L , 16	Digital input DI11...DI16 if VW3A3203 I/O extension module has been inserted
[CD00]... [CD10]	C d 0 0... C d 1 0	Virtual digital input CMD.0...CMD.10 in [I/O profile] , o configuration
[CD11]... [CD15]	C d 1 1... C d 1 5	Virtual digital input CMD.11...CMD.15 regardless of configuration
[C101]... [C110]	C 1 0 1... C 1 1 0	Virtual digital input CMD1.01...CMD1.10 with integrated Modbus Serial in [I/O profile] , o configuration
[C111]... [C115]	C 1 1 1... C 1 1 5	Virtual digital input CMD1.11...CMD1.15 with integrated Modbus Serial regardless of configuration
[C201]... [C210]	C 2 0 1... C 2 1 0	Virtual digital input CMD2.01...CMD2.10 with CANopen® fieldbus module in [I/O profile] , o configuration
[C211]... [C215]	C 2 1 1... C 2 1 5	Virtual digital input CMD2.11...CMD2.15 with CANopen® fieldbus module regardless of configuration
[C301]... [C310]	C 3 0 1... C 3 1 0	Virtual digital input CMD3.01...CMD3.10 with a fieldbus module in [I/O profile] , o configuration
[C311]... [C315]	C 3 1 1... C 3 1 5	Virtual digital input CMD3.11...CMD3.15 with a fieldbus module regardless of configuration
[C501]... [C510]	C 5 0 1... C 5 1 0	Virtual digital input CMD5.01...CMD5.10 with integrated Ethernet Modbus TCP in [I/O profile] , o configuration
[C511]... [C515]	C 5 1 1... C 5 1 5	Virtual digital input CMD5.11...CMD5.15 with integrated Ethernet Modbus TCP regardless of configuration
[DI1 (Low level)]...[DI6 (Low level)]	L , 1 L ...L , 6 L	Digital input DI1...DI6 used at low level

[Pipe Fill on Wake Up] P F W u ★

Pipe fill cycle on wake-up.

This parameter can be accessed if:

- [Access Level] L A C is set to [Expert] E P r .
- [Activation Mode] P F Π is not set to [No] n o .

Setting	Code / Value	Description
[No]	n o	No pipe fill cycle on wake-up
[Yes]	Y E S	A pipe fill cycle operates on wake-up Factory setting

[Pipe Fill Speed] P F H S ★

Pipe fill speed.

This parameter can be accessed if

- **[Activation Mode] P F Π** is not set to **[No]** *no*, and
- **[Activation Source] P F E c** is not set to **[Not Assigned]** *no*.

Setting (°)	Description
0.0...500.0 Hz	Setting range Factory setting: 25.0 Hz

[Pipe Fill Pressure] P F H P ★

Pipe fill pressure level.

This parameter can be accessed if

- **[Activation Mode] P F Π** is not set to **[No]** *no*, and
- **[Activation Source] P F E c** is not set to **[Not Assigned]** *no*.

Setting (°)	Description
0...32,767	Setting range according to [P sensor unit] S u P r . Factory setting: 0

[Pipe Fill Time] P F H t ★

Pipe fill time.

This parameter can be accessed if

- **[Activation Mode] P F Π** is not set to **[No]** *no*, and
- **[Activation Source] P F E c** is not set to **[Not Assigned]** *no*.

Setting (°)	Description
0...32,767 s	Setting range Factory setting: 10 s

[Pump functions] - [Friction loss compensation]

[Friction loss comp] $F L \mathcal{L} -$ Menu

Access

[Complete settings] \rightarrow [Pump functions] \rightarrow [Friction loss comp]

This menu can be accessed if:

- [Type of control] $\mathcal{L} \circ \mathcal{L} \mathcal{L}$ is set to [Pressure] $P r E 5 5$ and,
- [PID feedback] P , F is not set to [Not Configured] $n \circ$.

About This Menu

This function monitors the system flow and displays an estimation of the head losses of the application.

This function can compensate these head losses by modifying the pressure set point. It helps to maintain a constant pressure at usage point whatever the flow demand.

This monitoring function is at station level and not a pump level only.

This function requires a flow sensor to monitor the flow of the system.

The dynamic estimation of the losses is based on values measured by the application:

- The static losses [Static Compensation] $F L H \mathcal{D}$ measured at no flow between the pumping point and the usage point.
- The dynamic losses, based on an application working point (Flow [Flow at Point 1] $F L \mathcal{Q} I$; Head [Comp. at Point 1] $F L H I$) measured at nominal flow of the system.

If the function is set to compensation mode, the pressure set point is modified according to the estimated pressure drop.

NOTE: At low flow working point, as dynamic head losses are lower than at the nominal working point, this function reduces the pressure set point and thus allows saving electrical power.

[Mode Selection] $F L \mathcal{L} \Pi \star$

Mode selection.

Setting	Code / Value	Description
[Inactive]	$n \circ$	Inactive Factory setting
[Display]	$\Pi \circ n$	Monitoring only: pressure drop is not used for compensation
[Compensation]	$\mathcal{L} \circ \Pi P$	Compensation: pressure drop is used to correct pressure set-point

[Inst. Flow Assign.] $F 5 I A$

Installation flow sensor assignment.

This parameter can be accessed if [Mode Selection] $F L \mathcal{L} \Pi$ is not set to [No] $n \circ$.

Setting	Code / Value	Description
[Not Configured]	<i>n a</i>	Not assigned Factory setting
[AI1]...[AI3]	<i>R , 1...R , 3</i>	Analog input AI1...AI3
[AI4]...[AI5]	<i>R , 4...R , 5</i>	Analog input AI4...AI5 if VW3A3203 I/O extension module has been inserted
[AI Virtual 1]... [AI Virtual 3]	<i>R , V 1... R , V 3</i>	Virtual analogic input 1...3
[Di5 PulseInput Assignment]...[Di6 PulseInput Assignment]	<i>P , 5...P , 6</i>	Digital input DI5...DI6 used as pulse input
[Est. Pump Flow]	<i>S L P F</i>	Sensor less estimated flow
[Est. System Flow]	<i>S L S F</i>	Estimated system flow This selection is only possible if [Pump System Archit] <i>n P S R</i> is set to [Multi Drives] <i>n V S d</i> or [Multi Masters] <i>n V S d r</i> NOTE: To use this selection, all the pump characteristics of the system must be configured.
NOTE: For sensor configuration, refer to section [Sensors assignment] , page 200.		

[Friction loss comp] FLC - Menu

Access

[Complete settings] \rightarrow [Pump functions] \rightarrow [Friction loss comp]

About This Menu

The following parameters can be accessed if [Mode Selection] $FLCN$ is not set to [Inactive] no and [Inst. Flow Assign.] $FSIR$ is set to [Not Configured] no .

[Static Compensation] $FLHD$ ★

Static compensation.

Setting $\langle \rangle$	Description
0...32,767	Setting range Factory setting: 0

[Flow at Point 1] $FL9I$ ★

Flow at point 1.

Setting $\langle \rangle$	Description
0...32,767	Setting range Factory setting: 0

[Comp. at Point 1] $FLHI$ ★

Compensation at point 1.

Setting $\langle \rangle$	Description
0...32,767	Setting range Factory setting: 0

[Alpha] $FLdR$ ★

Alpha.

This parameter can be accessed if [Access Level] LRL is set to [Expert] EP .

Setting $\langle \rangle$	Description
0.0...2.0	Setting range Factory setting: 2.0

[Delta Pressure] $FLPd$ ★

Friction loss delta pressure.

Setting ()	Description
-32,768...32,767	Setting range Factory setting: _

[Pump functions] - [Jockey pump]

[Jockey pump] $J K P$ - Menu

Access

[Complete settings] \rightarrow [Pump functions] \rightarrow [Jockey pump]

About This Menu

This menu can be accessed if:

- **[Type of control]** $\llcorner \square \llcorner \llcorner$ is set to **[PRESSURE]** $P r E S S$, and
- **[PID feedback]** $P i F$ is assigned, and
- **[Sleep Detect Mode]** $S L P \Pi$ is not set to **[No]** $n o$.

This function allows managing a jockey pump.

The jockey pump can be:

- A direct on-line pump in parallel to the variable speed pump, controlled by a digital output, or
- The variable speed pump used at fixed speed.

The jockey pump works in on/off control between two pressure set points.

The jockey pump is used during sleep period to maintain the service pressure.

From an energy efficiency point of view, it is better to start and stop a fixed speed pump than running the variable speed pump continuously at low speed.

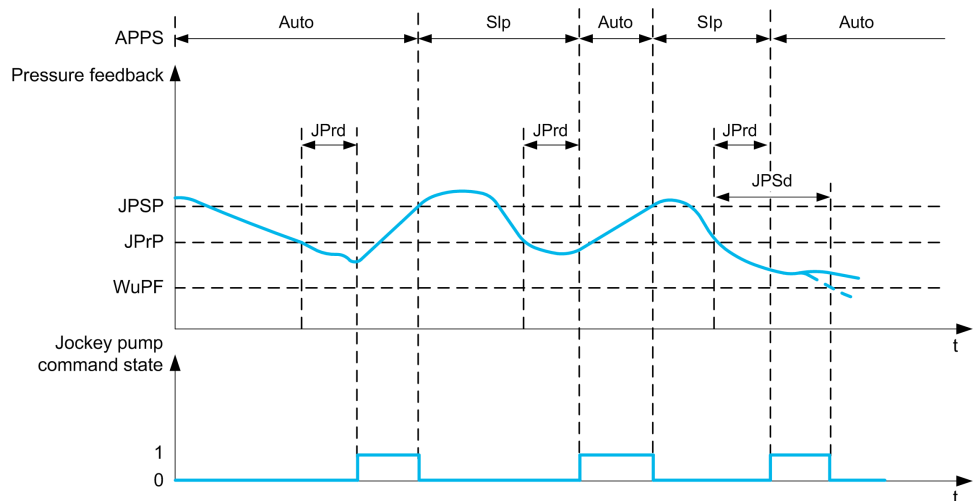

During sleep mode, the pressure feedback is still monitored:

- If the pressure feedback falls below the jockey start pressure **[Minimum Pressure]** $J P r P$ during a time longer than **[Delay to Start]** $J P r d$, the jockey pump is started;
- If the pressure feedback is over jockey stop pressure **[Maximum Pressure]** $J P S P$, the jockey pump is stopped

When the jockey pump is started, the pressure feedback is still monitored:

- If the pressure feedback stays below the jockey start pressure **[Maximum Pressure]** $J P S P$ for longer than the wake-up delay **[Wake Up Delay]** $J P W d$, it means that the request is greater than what jockey pump can supply alone. The system wakes up and exit from sleep mode.
- If the pressure feedback falls below the wake-up pressure **[Wake UP Process level]** $W u P F$, the system wakes up and exit from sleep mode.

[Jockey Selection] JP

Select the jockey pump.

Setting	Code / Value	Description
[No]	no	Not assigned Factory setting
[R2]...[R3]	r 2...r 3	Relay output R2...R3
[R4]...[R6]	r 4...r 6	Relay output R4...R6 if VW3A3204 relay output option module has been inserted
[DQ11 Digital Output]... [DQ12 Digital Output]	do 11... do 12	Digital output DQ11...DQ12 if VW3A3203 I/O extension module has been inserted
[VSP]	v 5 P	Variable speed pump controlled by the drive
[R61]...[R66]	r 6 1...r 6 6	Relay R61 ...R66 NOTE: This selection can be accessed on ATV660 and ATV680 equipped with Cabinet IO

[Minimum Pressure] JP r P★

Pressure threshold to start the jockey pump.

This parameter can be accessed if [Jockey Selection] JP is not set to [No] no.

Setting ()	Description
0...[Maximum Pressure] JP 5 P	Setting range Factory setting: 0

[Delay to Start] JP r d★

Delay to start the jockey pump.

This parameter can be accessed if [Jockey Selection] JP is not set to [No] no.

Setting ()	Description
0...3,600 s	Setting range Factory setting: 0 s

[Maximum Pressure] JP 5 P★

Pressure threshold to stop the jockey pump.

This parameter can be accessed if [Jockey Selection] JP is not set to [No] no.

Setting ()	Description
[Minimum Pressure] JP r P...32,767	Setting range Factory setting: 0

[Wake Up Delay] J P W d ★

Delay to wake up the system when pressure feedback stays low.

This parameter can be accessed if **[Jockey Selection] J P** is not set to **[No] n o**.

Setting ()	Description
[No] n o ...3,600 s	Setting range Factory setting: n o

[Reference Speed] J P r 5 ★

Pump speed when **[VSP] v 5 P** is selected as jockey pump.

This parameter can be accessed if **[Jockey Selection] J P** is set to **[VSP] v 5 P**.

Setting ()	Description
[Low Speed] L 5 P ... [High Speed] H 5 P	Setting range Factory setting: [Maximum Pressure] J P 5 P

[Pump functions] - [Priming pump ctrl]

[Priming pump ctrl] PPC - Menu

Access

[Complete settings] \rightarrow [Pump functions] \rightarrow [Priming pump ctrl]

About This Menu

This function manages a priming pump.

The priming pump is placed at the inlet of the variable speed lead pump, controlled with a digital output.

The priming pump is used to maintain the inlet pressure to the lead pump.

This is done by running the priming pump before the main pump starts. Nevertheless, it is recommended to enable the dry-Run monitoring function.

The priming pumps keep pumping as long as the lead pump is active.

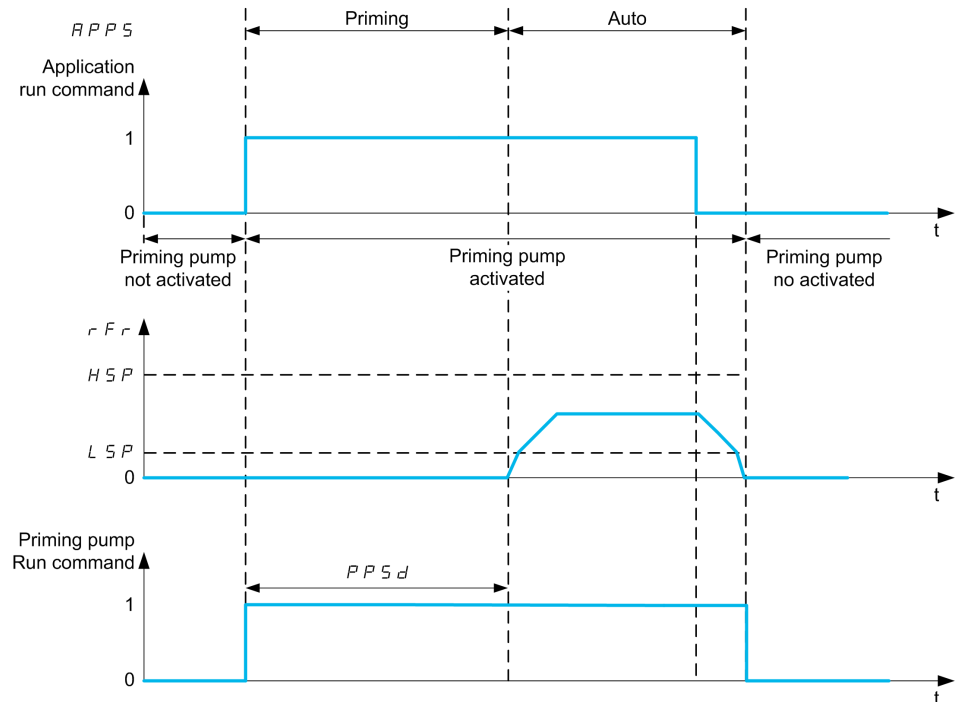

If the priming pump function is activated and the conditions to start the lead pump are present, the priming pump is started immediately while the lead pump will be started when one of the primed conditions is met :

- After the **[Priming Time] $PPSd$** delay
- When the digital input assigned with **[Primed Switch Assign] $PPWR$** is active for longer than **[Primed Condition Delay] $PPFd$** .
- When the analog input assigned with **[InletPres Assign] $PSIR$** is over **[Primed Inlet Level] $PPiL$** for longer than **[Primed Condition Delay] $PPFd$** .

If the priming pump is active, it is stopped when the lead pump is stopped, at the end of the deceleration phase.

When the system goes to the sleep mode, the priming pump is also deactivated.

When the system wakes up, the priming pump is immediately activated while the lead pump will be started when one of the primed conditions is met.

[Priming Pump Assign] P P 0 R

Select the priming pump.

Setting	Code / Value	Description
[No]	n 0	Not assigned Factory setting
[R2]...[R3]	r 2...r 3	Relay output R2...R3
[R4]...[R6]	r 4...r 6	Relay output R4...R6 if VW3A3204 relay output option module has been inserted
[DQ11 Digital Output]... [DQ12 Digital Output]	d 0 1 1... d 0 1 2	Digital output DQ11...DQ12 if VW3A3203 I/O extension module has been inserted
[R61]...[R66]	r 6 1...r 6 6	Relay R61 ...R66 NOTE: This selection can be accessed on ATV660 and ATV680 equipped with Cabinet IO

[Primed Switch Assign] P P W R ★

Primed condition: external switch assignment.

This parameter can be accessed if **[Priming Pump Assign] P P 0 R** is not set to **[No] n 0**.

Setting	Code / Value	Description
[Not Assigned]	n 0	Not assigned Factory setting
[DI1]...[DI6]	L 1 1...L 1 6	Digital input DI1...DI6
[DI11]...[DI16]	L 1 1 1... L 1 1 6	Digital input DI11...DI16 if VW3A3203 I/O extension module has been inserted
[DI1 (Low level)]...[DI6 (Low level)]	L 1 L ...L 6 L	Digital input DI1...DI6 used at low level

[Primed Inlet Level] P P , L ★

Primed condition: inlet pressure detection level.

This parameter can be accessed if **[Priming Pump Assign] P P 0 R** is not set to **[No] n 0**.

Setting	Code / Value	Description
[No]	0	Function disabled Factory setting
-3276.7...3276.7		Setting range according to the configuration done in the [Define system units] 5 5 5 - menu

[InletPres Assign] P 5 I R ★

Inlet pressure sensor assignment.

This parameter can be accessed if:

- **[Priming Pump Assign] P P 0 R** is not set to **[No] n 0**.
- **[Primed Inlet Level] P P , L** is not set to **[No] 0**.

Setting	Code / Value	Description
[Not Configured]	<i>n a</i>	Not assigned Factory setting
[AI1]...[AI3]	<i>R , 1...R , 3</i>	Analog input AI1...AI3
[AI4]...[AI5]	<i>R , 4...R , 5</i>	Analog input AI4...AI5 if VW3A3203 I/O extension module has been inserted
[AI Virtual 1]... [AI Virtual 3]	<i>R , V 1... R , V 3</i>	Virtual analogic input 1...3
NOTE: For sensor configuration, refer to section [Sensors assignment] , page 200.		

[Priming pump ctrl] P P C - Menu

Access

[Complete settings] → [Pump functions] → [Priming pump ctrl]

[Primed Condition Delay] P P F d★

Primed condition delay.

This parameter can be accessed if:

- [Priming Pump Assign] P P a R is not set to [No] n o .
- [Primed Switch Assign] P P w R is not set to [Not Assigned] n a .
- [Primed Inlet Level] P P i L is not set to [No] n o .

Setting ()	Description
0...60 s	Setting range Factory setting: 0 s

[Priming Time] P P S d★

Delay before starting the lead pump.

This parameter can be accessed if [Priming Pump Assign] P P a R is not set to [No] n o .

Setting ()	Description
0...3,600 s	Setting range Factory setting: 30 s

[Pump functions] - [Flow limitation]

[Flow limitation] $F L \Pi$ - Menu

Access

[Complete settings] → [Pump functions] → [Flow limitation]

About This Menu

This function allows you to limit the flow of the system to a configured value (according to local requirements, regulation, or availability of water).

This monitoring function is at station level and not a pump level only.

This function requires a flow sensor to monitor the flow of the system.

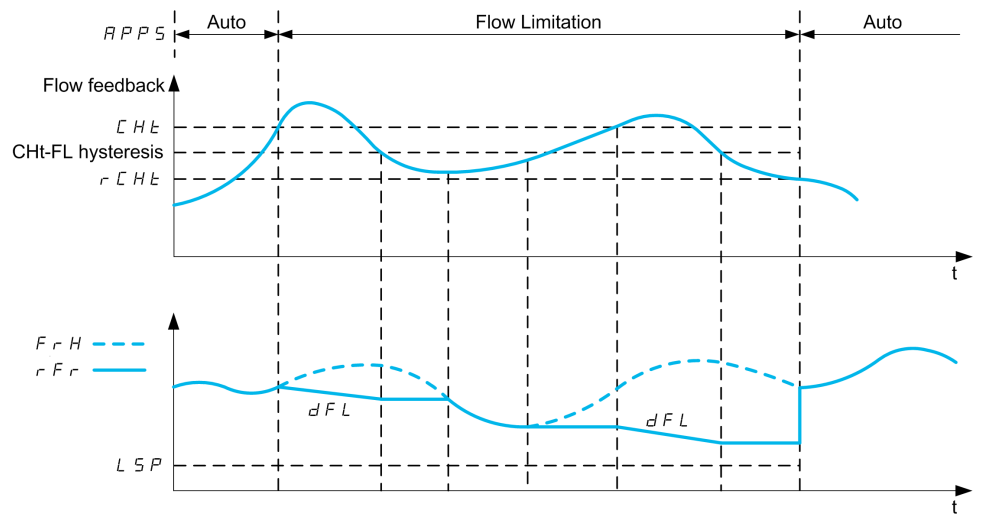

When the flow feedback is higher than the high flow **[Flow Lim Thd Active]** CHt , the pump reduces the speed set point according to the deceleration ramp **[Flow. Limit Dec.]** dFL .

When the flow feedback is lower than the high flow **[Flow Lim Thd Active]** CHt reduced by a fixed hysteresis value, the pump speed is maintained or reduced if the reference frequency decrease.

When the flow feedback is lower than the low flow **[FlowLim Thd Disable]** $r CHt$, the flow limitation stops and the pump speed follows the system reference frequency.

NOTE: This function does not decrease the motor speed under **[Low Speed]** LSP value.

[Flow limitation Mode] $F L \Pi$

Flow limitation mode.

Setting	Code / Value	Description
[No]	$n o$	No Factory setting
[YES]	$y e s$	Yes

[Inst. Flow Assign.] F 5 I R★

Installation flow sensor assignment.

This parameter can be accessed if **[Flow limitation Mode] F L M** is not set to **[No] n o**.

Setting	Code / Value	Description
[Not Configured]	<i>n o</i>	Not assigned Factory setting
[AI1]...[AI3]	<i>A 1...A 3</i>	Analog input AI1...AI3
[AI4]...[AI5]	<i>A 4...A 5</i>	Analog input AI4...AI5 if VW3A3203 I/O extension module has been inserted
[AI Virtual 1]... [AI Virtual 3]	<i>A V 1... A V 3</i>	Virtual analogic input 1...3
[Di5 PulseInput Assignment]...[Di6 PulseInput Assignment]	<i>P 5...P 6</i>	Digital input DI5...DI6 used as pulse input
[Est. Pump Flow]	<i>S L P F</i>	Sensor less estimated flow
[Est. System Flow]	<i>S L S F</i>	Estimated system flow This selection is only possible if [Pump System Archit] P S R is set to [Multi Drives] n V S d or [Multi Masters] n V S d r NOTE: To use this selection, all the pump characteristics of the system must be configured.
NOTE: For sensor configuration, refer to section [Sensors assignment] , page 200.		

[Flow limitation] F L Π - Menu

Access

[Complete settings] \rightarrow [Pump functions] \rightarrow [Flow limitation]

[Flow Lim Thd Active] \llcorner H E \star

Flow limitation function threshold activation.

Setting \llcorner	Description
Value in application customer unit	Setting range according to the configuration done in the [Define system units] S \llcorner E - menu. Factory setting: 0.0

[Flow.Lim.Thres.Inact.] r \llcorner H E \star

Flow limitation function threshold deactivation.

Setting \llcorner	Description
Value in application customer unit	Setting range according to the configuration done in the [Define system units] S \llcorner E - menu. Factory setting: 0.0

[Flow. Limit Dec.] d F L \star

Flow limitation function deceleration time (between F r S and 0).

Setting \llcorner	Description
0.01...99.99 s ⁽¹⁾	Setting range Factory setting: 5.0 s
(1) Range 0.01 to 99.99 s or 0.1 to 999.9 s or 1.0 to 6,000.0 according to [Ramp increment] i n r	

[Pump functions] - [Vortex Control]

[Vortex Control] $\mathcal{V} \mathcal{L} \mathcal{E} \mathcal{L} -$ Menu

Access

[Complete settings] → [Pump functions] → [Vortex Control]

About This Menu

This menu can be accessed if [Application Selection] $\mathcal{A} \mathcal{P} \mathcal{P} \mathcal{L}$ is set to [Generic Pump control] $\mathcal{G} \mathcal{P} \mathcal{P} \mathcal{P}$.

This function is used for applications which consist in emptying tanks. The decrease of the liquid level can lead to vortex formation, consequently impacting the hydraulic and mechanical performances of the motor-pump.

This function allows to:

- Detect vortex or air entrainment conditions.
- Provide an error report to the user in case of anomaly.
- Adapt the speed of the pump to reduce the vortex phenomenon.

[Activation] $\mathcal{V} \mathcal{L} \mathcal{P}$

Vortex control activation mode.

This parameter is used to activate the vortex control function.

This parameter can be configured if [PID Feedback assign] $\mathcal{P} \mathcal{F}$ is not configured and [Application Selection] $\mathcal{A} \mathcal{P} \mathcal{P} \mathcal{L}$ is set to [Generic Pump control] $\mathcal{G} \mathcal{P} \mathcal{P} \mathcal{P}$.

Setting	Code / Value	Description
[No]	$\mathcal{N} \mathcal{O}$	Function is not activated Factory Setting
[Yes]	$\mathcal{Y} \mathcal{E} \mathcal{S}$	Function activated

[Curve Learn Mode] $\mathcal{V} \mathcal{L} \mathcal{L} \mathcal{P}$

Vortex control Learning mode.

This parameter is accessible if [Activation] $\mathcal{V} \mathcal{L} \mathcal{P}$ is set to [Yes] $\mathcal{A} \mathcal{P} \mathcal{P} \mathcal{L} \mathcal{Y} \mathcal{E} \mathcal{S}$.

Note: The setting of the parameters [Low Speed] $\mathcal{L} \mathcal{S} \mathcal{P}$, [High Speed] $\mathcal{H} \mathcal{S} \mathcal{P}$, [Low Learning speed] $\mathcal{V} \mathcal{L} \mathcal{S} \mathcal{J}$, [High Learning speed] $\mathcal{V} \mathcal{L} \mathcal{S} \mathcal{K}$ and [Learning Stab. Time] $\mathcal{V} \mathcal{L} \mathcal{S} \mathcal{E}$ must not be modified during the learning phase in the vortex control, (i.e [Curve learn mode] $\mathcal{V} \mathcal{L} \mathcal{L} \mathcal{P}$ is set to [Learnt curve mode] $\mathcal{L} \mathcal{E} \mathcal{A} \mathcal{R} \mathcal{N}$). If one of these parameters setting is modified, it is recommended to restart the learning.

Setting	Code / Value	Description
[Preset Curve Mode]	$\mathcal{P} \mathcal{S} \mathcal{E} \mathcal{L}$	Preset mode Factory Setting
[Learnt Curve Mode]	$\mathcal{L} \mathcal{E} \mathcal{A} \mathcal{R} \mathcal{N}$	Learning mode.

[Status] V C C 5

Vortex control status.

This parameter is accessible if [Activation] V C Π is set to [Yes] *APPEYES*.

Setting	Code / Value	Description
[Not configured]	<i>none</i>	Function not configured This setting is not accessible by Graphic display Terminal.
[Inactive]	<i>not</i>	Function not active
[Pending]	<i>watch</i>	Function is monitoring the vortex condition
[Running]	<i>ctrl</i>	Function is adapting the speed to control the vortex
[Runs With Warning]	<i>warn</i>	Warning is active. The function cannot adapt the speed to control the vortex
[Error]	<i>fault</i>	Error is active

[Curve Learn Status] V C L 5

Vortex control learning status.

This parameter is accessible if [Activation] V C Π is set to [Yes] *APPEYES* and [Curve Learn Mode] V C L Π is set to [Learnt Curve Mode] *learn*.

Setting	Code / Value	Description
[Preset Value Mode]	<i>psel</i>	Preset values are used This setting is not accessible by Graphic display Terminal.
[Inactive]	<i>not</i>	Function not active This setting is not accessible by Graphic display Terminal.
[Pending]	<i>pen</i>	Function is monitoring the vortex condition
[Running]	<i>run</i>	Function is adapting the speed to control the vortex
[Error]	<i>fail</i>	Learning has been unsuccessful or preset values are not correct
[Succeeded]	<i>done</i>	Learning has been performed successfully

NOTE: During the learning sequence (i.e [Curve Learn Status] V C L 5 is set to [Running] *run*), if a stop command is given, the learning sequence stops and [Curve Learn Status] V C L 5 is set to [Pending] *pen*. The learning sequence is reset and restarts at the next run command.

[Learning Act. Assign] V C L A

Vortex Control learning activation assignment.

This parameter is accessible if V C L Π is set to [Learnt Curve Mode] *learn*.

Setting	Code / Value	Description
[Not Assigned]	<i>no</i>	Learning mode not activated Factory setting
[YES]	<i>yes</i>	Yes
[DI1]...[DI6]	<i>L1...L6</i>	Digital input DI1...DI6
[DI11]...[DI16]	<i>L11...L16</i>	Digital input DI11...DI16 if VW3A3203 I/O extension module has been inserted

Setting	Code / Value	Description
[DI1 (Low level)]...[DI6 (Low level)]	L 1 L ... L 6 L	Digital input DI1...DI6 used at low level
[DI11 (Low level)]...[DI16 (Low level)]	L 1 1 L ... L 1 6 L	Digital input DI11...DI16 used at low level if VW3A3203 Extended I/O module has been inserted
[CD00]... [CD10]	C d 0 0 ... C d 1 0	Virtual digital input CMD.0...CMD.10 in [I/O profile] , a configuration
[CD11]... [CD15]	C d 1 1 ... C d 1 5	Virtual digital input CMD.11...CMD.15 regardless of configuration
[C101]... [C110]	C 1 0 1 ... C 1 1 0	Virtual digital input CMD1.01...CMD1.10 with integrated Modbus Serial in [I/O profile] , a configuration
[C111]... [C115]	C 1 1 1 ... C 1 1 5	Virtual digital input CMD1.11...CMD1.15 with integrated Modbus Serial regardless of configuration
[C201]... [C210]	C 2 0 1 ... C 2 1 0	Virtual digital input CMD2.01...CMD2.10 with CANopen® fieldbus module in [I/O profile] , a configuration
[C211]... [C215]	C 2 1 1 ... C 2 1 5	Virtual digital input CMD2.11...CMD2.15 with CANopen® fieldbus module regardless of configuration
[C301]... [C310]	C 3 0 1 ... C 3 1 0	Virtual digital input CMD3.01...CMD3.10 with a fieldbus module in [I/O profile] IO configuration
[C311]... [C315]	C 3 1 1 ... C 3 1 5	Virtual digital input CMD3.11...CMD3.15 with a fieldbus module regardless of configuration
[C501]... [C510]	C 5 0 1 ... C 5 1 0	Virtual digital input CMD5.01...CMD5.10 with integrated Ethernet Modbus TCP in [I/O profile] , a configuration
[C511]... [C515]	C 5 1 1 ... C 5 1 5	Virtual digital input CMD5.11...CMD5.15 with integrated Ethernet Modbus TCP regardless of configuration

[Low Learning speed] V C 5 J

Vortex control minimal learning speed.

This parameter is accessible if V C L P is set to [Learnt Curve Mode] L E R r n .

Note: The setting of this parameter must not be modified during the learning phase in the vortex control , page 382 (i.e [Curve learn mode] V C L P is set to [Learnt curve mode] L E R r n). If setting modified, it is recommended to restart the learning.

Setting	Description
0.0...500.0 Hz	Setting range Factory setting: 0 Hz

[High Learning speed] V C 5 K

Vortex control maximal learning speed.

This parameter is accessible if V C L P is set to [Learnt Curve Mode] L E R r n .

The factory setting changes to 60 Hz if [Motor Standard] b F r = [60 Hz NEMA] B D .

Note: The setting of this parameter must not be modified during the learning phase in the vortex control , page 382 (i.e [Curve learn mode] V C L P is set to [Learnt curve mode] L E R r n). If setting modified, it is recommended to restart the learning.

Setting	Description
0.0...500.0 Hz	Setting range Factory setting: 50Hz

[Learning Stab. Time] $\bar{V} \bar{C} \bar{S} \bar{E}$

Vortex control learning stabilization time.

This parameter is accessible if $\bar{V} \bar{C} \bar{L} \bar{P}$ is set to **[Learnt Curve Mode] $\bar{L} \bar{E} \bar{A} \bar{r} \bar{n}$** .

Note: The setting of this parameter must not be modified during the learning phase in the vortex control, page 382 (i.e. **[Curve learn mode] $\bar{V} \bar{C} \bar{L} \bar{P}$** is set to **[Learnt curve mode] $\bar{L} \bar{E} \bar{A} \bar{r} \bar{n}$**). If setting modified, it is recommended to restart the learning.

Setting	Description
0...100 s	Setting range Factory setting: 3s

[Learnt Speed #1] $\bar{V} \bar{C} \bar{S} \bar{I}$

Vortex control learning speed for point 1.

Setting	Description
0...500.0 Hz	Setting range Factory setting: 0.0 Hz

[Learnt Power #1] $\bar{V} \bar{C} \bar{P} \bar{I}$

Vortex control learning power for point 1.

Setting	Description
0... $\frac{[\text{Nominal Motor Power}] \bar{n} \bar{P} \bar{r} \times 2}{}$	Setting range in kW if [Motor Standard] $\bar{b} \bar{F} \bar{r}$ is set to [50 Hz] $\bar{S} \bar{D}$, in HP if [Motor Standard] $\bar{b} \bar{F} \bar{r}$ is set to [60 Hz] $\bar{E} \bar{D}$. Factory setting: 0

[Learnt Speed #2] $\bar{V} \bar{C} \bar{S} \bar{2}$

Vortex control learning speed for point 2.

Identical to **[Learnt Speed #1] $\bar{V} \bar{C} \bar{S} \bar{I}$** .

[Learnt Power #2] $\bar{V} \bar{C} \bar{P} \bar{2}$

Vortex control learning power for point 2.

Identical to **[Learnt Power #1] $\bar{V} \bar{C} \bar{P} \bar{I}$** .

[Learnt Speed #3] $\bar{V} \bar{C} \bar{S} \bar{3}$

Vortex control learning speed for point 3.

Identical to **[Learnt Speed #1] $\bar{V} \bar{C} \bar{S} \bar{I}$** .

[Learnt Power #3] V C P 3

Vortex control learning power for point 3.

Identical to **[Learnt Power #1] V C P 1**.

[Learnt Speed #4] V C 5 4

Vortex control learning speed for point 4.

Identical to **[Learnt Speed #1] V C 5 1**.

[Learnt Power #4] V C P 4

Vortex control learning power for point 4.

Identical to **[Learnt Power #1] V C P 1**.

[Learnt Speed #5] V C 5 5

Vortex control learning speed for point 5.

Identical to **[Learnt Speed #1] V C 5 1**.

[Learnt Power #5] V C P 5

Vortex control learning power for point 5.

Identical to **[Learnt Power #1] V C P 1**.

[Ctrl Disable DI Assign.] V C d A

Vortex control disable assignment.

This parameter is accessible if **[Activation] V C A** is set to **[Yes] Y E 5**.

Setting	Code / Value	Description
[Not Assigned]	n o	Learning mode not activated Factory setting
[YES]	Y E 5	Yes
[DI1]...[DI6]	L 1 I ... L 6	Digital input DI1...DI6
[DI11]...[DI16]	L 1 I I ... L 1 6	Digital input DI11...DI16 if VW3A3203 I/O extension module has been inserted
[DI1 (Low level)]...[DI6 (Low level)]	L 1 L ... L 6 L	Digital input DI1...DI6 used at low level
[DI11 (Low level)]...[DI16 (Low level)]	L 1 I L ... L 1 6 L	Digital input DI11...DI16 used at low level if VW3A3203 Extended I/O module has been inserted
[CD00]...[CD10]	C d 0 0 ... C d 1 0	Virtual digital input CMD.0...CMD.10 in [I/O profile] i o configuration
[CD11]...[CD15]	C d 1 1 ... C d 1 5	Virtual digital input CMD.11...CMD.15 regardless of configuration
[C101]...[C110]	C 1 0 1 ... C 1 1 0	Virtual digital input CMD1.01...CMD1.10 with integrated Modbus Serial in [I/O profile] i o configuration
[C111]...[C115]	C 1 1 1 ... C 1 1 5	Virtual digital input CMD1.11...CMD1.15 with integrated Modbus Serial regardless of configuration

Setting	Code / Value	Description
[C201]... [C210]	C 2 0 1... C 2 1 0	Virtual digital input CMD2.01...CMD2.10 with CANopen® fieldbus module in [I/O profile] IO configuration
[C211]... [C215]	C 2 1 1... C 2 1 5	Virtual digital input CMD2.11...CMD2.15 with CANopen® fieldbus module regardless of configuration
[C301]... [C310]	C 3 0 1... C 3 1 0	Virtual digital input CMD3.01...CMD3.10 with a fieldbus module in [I/O profile] IO configuration
[C311]... [C315]	C 3 1 1... C 3 1 5	Virtual digital input CMD3.11...CMD3.15 with a fieldbus module regardless of configuration
[C501]... [C510]	C 5 0 1... C 5 1 0	Virtual digital input CMD5.01...CMD5.10 with integrated Ethernet Modbus TCP in [I/O profile] IO configuration
[C511]... [C515]	C 5 1 1... C 5 1 5	Virtual digital input CMD5.11...CMD5.15 with integrated Ethernet Modbus TCP regardless of configuration

[Pwr/Spd Curve Gain] V C R X

Factor applied on the Power vs Speed curve.

This parameter is accessible if [Activation] V C R is set to [Yes] Y E 5.

Setting	Description
0...200%	Setting range Factory setting: 95%

[Pwr/Spd Curve Offset] V C R Y

Negative offset applied on the Power vs Speed curve.

This parameter is accessible if [Activation] V C R is set to [Yes] Y E 5.

Setting	Description
0...[Nominal Motor Power] n P r x 2	Setting range in kW if [Motor Standard] b F r is set to [50 Hz] 5 0, in HP if [Motor Standard] b F r is set to [60 Hz] 6 0. Factory setting: 0

[Prp. Gain] V C K P

The proportional gain

This parameter is accessible if [Activation] V C R is set to [Yes] Y E 5.

Setting	Description
0.01...2.00	Setting range Factory setting: 1.00

[Integ Cst Time] V C E ,

The integral constant time

This parameter is accessible if [Activation] V C R is set to [Yes] Y E 5.

Setting	Description
0...100 s	Setting range Factory setting: 5 s

[Error Delay] V L F d

The delay before the [VxCtrl Error] V L F error is triggered.

This parameter is accessible if [Activation] V L n is set to [Yes] Y E S.

Setting	Description
0...60 s	Setting range Factory setting: 10 s

[Error Behavior] V L F b

Vortex control response to the detected [VxCtrl Error] V L F error.

This parameter is accessible if [Activation] V L n is set to [Yes] Y E S.

Setting	Code / Value	Description
[Ignore]	n o	Detected error ignored
[Freewheel Stop]	Y E S	Freewheel stop
[Per STT]	S E E	Stop according to [Type of stop] S E E parameter but without an error triggered after stop
[Fallback Speed]	L F F	Change to fallback speed, maintained as long as the detected error persists and the command has not been removed ⁽¹⁾
[Ramp stop]	r n P	Stop on ramp Factory setting

(1) Because, in this case, the detected error does not trigger a stop, it is recommended to assign a relay or logic output to its indication

[Fallback Speed] L F F

Fallback speed

This parameter is accessible if [Error Behavior] V L F b is set to [Fallback Speed] L F F.

Setting	Description
0...500.0 Hz	Setting range Factory setting: 0.0 Hz

[Pump monitoring] - [Pumpcycle monitoring]

[Pumpcycle monitoring] C 5 P - Menu

Access

[Complete settings] → [Pump monitoring] → [Pumpcycle monitoring]

About This Menu

The purpose of this function is to monitor the number of start sequences during a configured time window in order to prevent from an unwanted aging of the system and to detect any abnormal operation.

An internal counter counts the number of pump start sequences. Each time the pump is started, the counter is incremented. It is decreased by one every time window corresponding to one start.

If the counter reaches the maximum number allowed **[PumpCycle MaxStarts]** $PCPn$, a warning **[Pump Cycle warning]** $PCPA$ is triggered.

If a start command occurs while the detected warning is active, an error **[PumpCycle Start Error]** $PCPF$ is triggered. The application follows the **[PumpCycleError Resp]** $PCPB$ defined behavior.

Restarting the pump is allowed as soon as the counter decreases under the maximum number of starts allowed, if the detected error has been cleared.

The function is based on the sliding time window in which the pump start commands are counted.

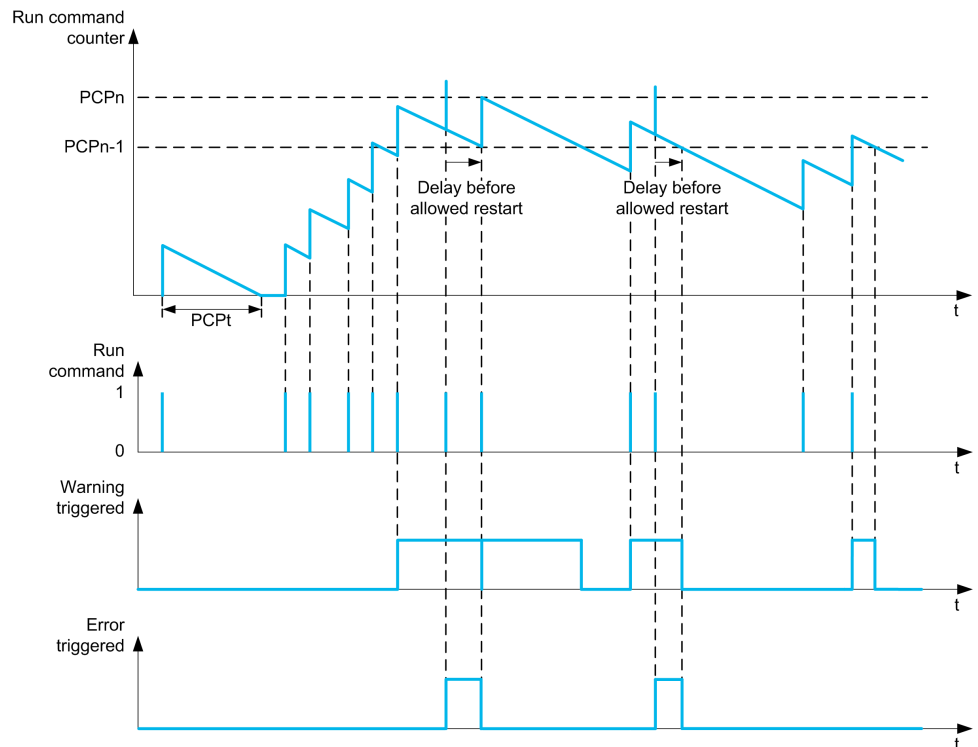

If **[PumpCycle Monitoring]** $PCPN$ is set to **[Mode 1]** $norN$, the function is activated without power Off time management.

If **[PumpCycle Monitoring]** $PCPN$ is set to **[Mode 2]** rEL , the function is activated with power Off time management. This requires a time clock source such as the Graphic Display Terminal plugged at power On of the drive, or a Time server configured over Ethernet.

NOTE: Anti-Jam sequence is counted as one start whatever the effective number of start commands in the sequence.

[PumpCycle Monitoring] P C P Π

Pumpcycle monitoring mode.

Setting	Code / Value	Description
[No]	n o	Cyclic monitoring disabled Factory setting
[Mode 1]	n o r Π	Cyclic monitoring without power off time management
[Mode 2]	r E C	Cyclic monitoring with power off time management

[PumpCycle MaxStarts] P C P n★

Maximum number of events to trip.

This parameter can be accessed if [PumpCycle Monitoring] P C P Π is not set to [No] n o.

Setting ()	Description
1...99	Setting range Factory setting: 6

[PumpCycle Timeframe] P C P E★

Window time.

This parameter can be accessed if P C P Π is not set to [Inactive] n o.

Setting ()	Description
0...3,600 min	Setting range Factory setting: 60 min

[PumpCycleError Resp] P C P b★

Pumpcycle monitoring response to a detected error.

This parameter can be accessed if P C P Π is not set to [Inactive] n o.

Setting	Code / Value	Description
[Ignore]	n o	Detected error ignored
[Freewheel Stop]	y E S	Freewheel stop
[Per STT]	S E E	Stop according to [Type of stop] S E E parameter but without an error triggered after stop
[Fallback Speed]	L F F	Change to fallback speed, maintained as long as the detected error persists and the command has not been removed (1)
[Ramp stop]	r Π P	Ramp stop Factory setting
1 Because, in this case, the detected error does not trigger a stop, it is recommended to assign a relay or logic output to its indication.		

[Fallback Speed] *L F F* ★

Fallback speed.

This parameter can be accessed if **[PumpCycleError Resp] *P C P B*** is set to **[Fallback Speed] *L F F***.

Setting	Description
0.0...500.0 Hz	Setting range Factory setting: 0.0 Hz

[Pump monitoring] - [Anti jam]

[Anti-jam monit] J A Π - Menu

Access

[Complete settings] → [Pump monitoring] → [Anti-jam monit]

About This Menu

In waste water applications, clogging substances reduce the efficiency of the system and may decrease the pump service life.

It may also help to clear a blocked impeller, pipe, or valve at downstream location.

The anti-Jam function allows, manually and/or automatically, to execute forward and reverse pump rotation cycles.

The frequency reference, acceleration and deceleration, in forward and in reverse direction can be adjusted by dedicated parameters. It allows you to set up the function in accordance with the application specifications. Refer to the pump datasheet while setting up the function.

NOTE: The anti-Jam configuration overrides other configurations such as [PID acceleration time] A C C P or [Start Accel Ramp] A C C 5.

NOTICE
<p>DAMAGE TO THE PUMP</p> <p>This function uses forward and reverse operations. Verify that the pump and the installation are compatible with reverse operation before setting up this function.</p> <p>Failure to follow these instructions can result in equipment damage.</p>

Anti-Jam Cycle

The anti-Jam function can be triggered:

- By an external trigger that can be assigned to a digital input (or word bit in IO profile).
- Automatically:
 - An automatic trigger can occur at each start command, or
 - Automatic triggers can occur within a predefined duration, or
 - Automatic triggers can occur depending on the motor torque threshold monitoring.

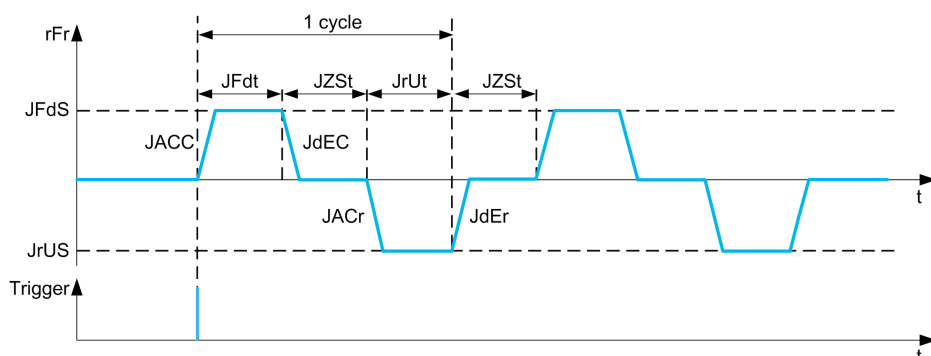

An Anti-Jam cycle is composed of:

- 1 forward action according to **[Anti-Jam Fwd Acc]** J R C C , **[Anti-Jam Fwd Time]** J F d E , **[Anti-Jam Fwd Speed]** J F d S , **[Anti-Jam Fwd Dec]** J d E C ,
- 1 stop action during **[Anti-Jam Stop Time]** J Z S E ,
- 1 reverse action according to **[Anti-Jam Rv Acc]** J R C r , **[Anti-Jam Rv Time]** J r d E , **[Anti-Jam Rv Speed]** J r V S , **[Anti-Jam Rv Dec]** J d E r ,
- 1 stop action during **[Anti-Jam Stop Time]** J Z S E ,

An Anti-Jam sequence corresponds to a number of consecutive anti-Jam cycles: **[Anti-Jam Cycle Nb]** J n b C

NOTE: In case of an external trigger, if the command is removed before the end of the anti-Jam sequence, the anti-Jam sequence continues up to the end. In addition to the trigger, a run command is necessary during the whole anti-Jam sequence.

Anti-Jam Counting

The anti-Jam function monitors the number of sequences during a configured time window **[Anti-Jam Interval]** J R n E . It helps to detect untimely aging of the system and abnormal operation. For example, it occurs on an automatic trigger on a motor torque threshold.

An internal counter counts the number of sequences. Each time the sequence is started, the counter is incremented. It is decremented for each time window corresponding to one start.

If the counter reaches the maximum number allowed, **[Anti-Jam Max Seq]** J R n n , a warning **[Anti-Jam Warning]** J R n R and an error **[Anti Jam Error]** J R n F are triggered. The application follows the **[Anti-Jam Error Resp]** J R n b behavior defined.

[Anti-Jam Ext Trig] J E E C

Switch input selection.

Setting	Code / Value	Description
[Not Assigned]	n o	Not assigned Factory setting
[DI1]...[DI6]	L , 1...L , 6	Digital input DI1...DI6
[DI11]...[DI16]	L , 11... L , 16	Digital input DI11...DI16 if VW3A3203 I/O extension module has been inserted
[CD00]... [CD10]	C d 0 0... C d 1 0	Virtual digital input CMD.0...CMD.10 in [I/O profile] , o configuration
[CD11]... [CD15]	C d 1 1... C d 1 5	Virtual digital input CMD.11...CMD.15 regardless of configuration
[C101]... [C110]	C 1 0 1... C 1 1 0	Virtual digital input CMD1.01...CMD1.10 with integrated Modbus Serial in [I/O profile] , o configuration
[C111]... [C115]	C 1 1 1... C 1 1 5	Virtual digital input CMD1.11...CMD1.15 with integrated Modbus Serial regardless of configuration
[C201]... [C210]	C 2 0 1... C 2 1 0	Virtual digital input CMD2.01...CMD2.10 with CANopen® fieldbus module in [I/O profile] , o configuration
[C211]... [C215]	C 2 1 1... C 2 1 5	Virtual digital input CMD2.11...CMD2.15 with CANopen® fieldbus module regardless of configuration
[C301]... [C310]	C 3 0 1... C 3 1 0	Virtual digital input CMD3.01...CMD3.10 with a fieldbus module in [I/O profile] , o configuration
[C311]... [C315]	C 3 1 1... C 3 1 5	Virtual digital input CMD3.11...CMD3.15 with a fieldbus module regardless of configuration

Setting	Code / Value	Description
[C501]... [C510]	C 5 0 1 ... C 5 1 0	Virtual digital input CMD5.01...CMD5.10 with integrated Ethernet Modbus TCP in [I/O profile] , o configuration
[C511]... [C515]	C 5 1 1 ... C 5 1 5	Virtual digital input CMD5.11...CMD5.15 with integrated Ethernet Modbus TCP regardless of configuration
[DI1 (Low level)]...[DI6 (Low level)]	L 1 L ...L 6 L	Digital input DI1...DI6 used at low level

[Automatic Anti-Jam trigger] J A E C

Anti-Jam trigger mode.

Setting	Code / Value	Description
[No]	n o	Inactive
[Start]	S t a r t	An automatic trigger occurs at each start command
[Time]	t , n e	Automatic triggers occur within a predefined duration
[Torque]	t o r q u e	Automatic triggers can occur depending on the motor torque threshold monitoring.

[Anti-Jam Trigger Time] J E C E ★

Inactive time before triggering an Anti-Jam when the pump has not been running.

This parameter can be accessed if [Anti-Jam Auto Trig] J A E C is set to [Time] t , n e .

Setting ()	Description
0...9,999 h	Setting range Factory setting: 24 h

[Anti-jam Torque] J E C L ★

Level of torque to trigger.

This parameter can be accessed if [Anti-Jam Auto Trig] J A E C is set to [Torque] t o r q u e .

Setting ()	Description
10...150%	Setting range Factory setting: 110%

[Anti-Jam Start Delay] J E C d ★

Delay to trigger when an overtorque is detected.

This parameter can be accessed if [Anti-Jam Auto Trig] J A E C is set to [Torque] t o r q u e .

Setting ()	Description
0...3,600 s	Setting range Factory setting: 10 s

[Anti-Jam Fwd Acc] J A C C ★

Anti-Jam acceleration in forward.

This parameter can be accessed if:

- [Anti-Jam Ext Trig] J E E C is not set to [No] n o, or
- [Anti-Jam Auto Trig] J A E C is not set to [No] n o.

Setting ()	Description
By default, with $i n r = 0.1$: 0.00...300.00 s	Setting range Factory setting: 3 s
If $i n r = 0.01$: 0.00...30.00 s	Setting range
If $i n r = 1$: 0.00...3000.00 s	Setting range

[Anti-Jam Fwd Dec] J D E C ★

Anti-Jam deceleration in forward.

This parameter can be accessed if:

- [Anti-Jam Ext Trig] J E E C is not set to [No] n o, or
- [Anti-Jam Auto Trig] J A E C is not set to [No] n o.

Setting ()	Description
By default, with $i n r = 0.1$: 0.00...300.00 s	Setting range Factory setting: 3 s
If $i n r = 0.01$: 0.00...30.00 s	Setting range
If $i n r = 1$: 0.00...3000.00 s	Setting range

[Anti-Jam Rv Acc] J A C r ★

Anti-Jam acceleration in reverse.

This parameter can be accessed if:

- [Anti-Jam Ext Trig] J E E C is not set to [No] n o, or
- [Anti-Jam Auto Trig] J A E C is not set to [No] n o.

Setting ()	Description
By default, with $i n r = 0.1$: 0.00...300.00 s	Setting range Factory setting: 3 s
If $i n r = 0.01$: 0.00...30.00 s	Setting range
If $i n r = 1$: 0.00...3000.00 s	Setting range

[Anti-Jam Rv Dec] J d E r ★

Anti-Jam deceleration in reverse.

This parameter can be accessed if:

- **[Anti-Jam Ext Trig] J E t C** is not set to **[No] n o**, or
- **[Anti-Jam Auto Trig] J R t C** is not set to **[No] n o**.

Setting (°)	Description
By default, with $i n r = 0.1$: 0.00...300.00 s	Setting range Factory setting: 3 s
If $i n r = 0.01$: 0.00...30.00 s	Setting range
If $i n r = 1$: 0.00...3000.00 s	Setting range

[Anti-Jam Fwd Speed] J F d 5 ★

Anti-Jam speed in forward.

This parameter can be accessed if:

- **[Anti-Jam Ext Trig] J E t C** is not set to **[No] n o**, or
- **[Anti-Jam Auto Trig] J R t C** is not set to **[No] n o**.

Setting (°)	Description
0.0...500.0 Hz	Setting range Factory setting: 0.0 Hz

[Anti-Jam Rv Speed] J r d 5 ★

Anti-Jam speed in reverse.

This parameter can be accessed if:

- **[Anti-Jam Ext Trig] J E t C** is not set to **[No] n o**, or
- **[Anti-Jam Auto Trig] J R t C** is not set to **[No] n o**.

Setting (°)	Description
0.0...500.0 Hz	Setting range Factory setting: 0.0 Hz

[Anti-Jam Fwd Time] J F d t ★

Anti-Jam time in forward.

This parameter can be accessed if:

- **[Anti-Jam Ext Trig] J E t C** is not set to **[No] n o**, or
- **[Anti-Jam Auto Trig] J R t C** is not set to **[No] n o**.

Setting ()	Description
0...300 s	Setting range Factory setting: 1 s

[Anti-Jam Rv Time] J r v t ★

Anti-Jam time in reverse.

This parameter can be accessed if:

- **[Anti-Jam Ext Trig] J E t C** is not set to **[No] n o**, or
- **[Anti-Jam Auto Trig] J R t C** is not set to **[No] n o**.

Setting ()	Description
0...300 s	Setting range Factory setting: 1 s

[Anti-Jam Stop Time] J Z s t ★

Anti-Jam time between forward and reverse.

This parameter can be accessed if:

- **[Anti-Jam Ext Trig] J E t C** is not set to **[No] n o**, or
- **[Anti-Jam Auto Trig] J R t C** is not set to **[No] n o**.

Setting ()	Description
0...300 s	Setting range Factory setting: 0 s

[Anti-Jam Cycle Nb] J n b C ★

Anti-Jam cycle number.

This parameter can be accessed if:

- **[Anti-Jam Ext Trig] J E t C** is not set to **[No] n o**, or
- **[Anti-Jam Auto Trig] J R t C** is not set to **[No] n o**.

Setting ()	Description
1...100	Setting range Factory setting: 10

[Anti-Jam Max Seq] J R n n ★

Maximum consecutive anti-Jam sequences allowed.

This parameter can be accessed if:

- **[Anti-Jam Ext Trig] J E t C** is not set to **[No] n o**, or
- **[Anti-Jam Auto Trig] J R t C** is not set to **[No] n o**.

Setting ()	Description
1...99	Setting range Factory setting: 2

[Anti-Jam Interval] J A N E ★

Anti-Jam minimum time between two non-consecutive sequences.

This parameter can be accessed if:

- **[Anti-Jam Ext Trig] J E E C** is not set to **[No] n o**, or
- **[Anti-Jam Auto Trig] J A E C** is not set to **[No] n o**.

Setting ()	Description
0...3,600 s	Setting range Factory setting: 60 s

[Anti-Jam Error Resp] J A N B ★

Anti-Jam monitoring function response to a detected error.

This parameter can be accessed if:

- **[Anti-Jam Ext Trig] J E E C** is not set to **[No] n o**, or
- **[Anti-Jam Auto Trig] J A E C** is not set to **[No] n o**.

Setting	Code / Value	Description
[Ignore]	n o	Detected error ignored
[Freewheel Stop]	Y E S	Freewheel stop Factory setting
[Per STT]	S E E	Stop according to [Type of stop] S E E parameter but without an error triggered after stop
[Fallback Speed]	L F F	Change to fallback speed, maintained as long as the detected error persists and the run command has not been removed ⁽¹⁾
[Ramp stop]	r n P	Stop on ramp
<p>1 Because, in this case, the detected error does not trigger a stop, it is recommended to assign a relay or logic output to its indication.</p>		

[Pump monitoring] - [Dry run Monit]

[Dry run Monit] $d Y r$ - Menu

Access

[Complete settings] \rightarrow [Pump monitoring] \rightarrow [Dry run Monit]

Dry-Run Condition

A dry-run condition occurs when the pump impeller is not totally submerged. Working in dry running during a long time can cause premature wear of the pump impeller.

Dry run occurs when there is excessive air in the suction pipe:

- Because the pump is not primed, or
- Due to excessive air leak in the suction line.

This significantly may reduce the bearings and seal service life due to high temperature raise and poor lubrication.

About This Menu

This function prevents the pump from operating in dry condition.

The dry-run function monitors the flow using:

- a flow switch, or
- a set of 2 points (speed; power) for a flow estimation.

When using a flow switch, the dry-run condition occurs when the switch is at a high level.

NOTE: It is recommended to use a flow switch that is open in case of a low flow and to use a digital input active at low level (DIxL). This allows you to stop the pump in case of a broken wire of the flow switch.

During the function setup, it is necessary to perform measurements at no-flow but with water in the system.

When using the flow estimation, the dry-run condition occurs if the estimated flow is lower than the no-flow power curve by **[Dry Run Factor] $d r Y X$** .

The no-flow power curve is defined by a set of 2 points:

- Minimum speed **[Low Speed] $n F L S$** ; Power at minimum speed **[Low Power] $n F L P$**
- Maximum speed **[High Speed] $n F H S$** ; Power at maximum speed **[High Power] $n F H P$**

This no-flow power curve is also used by the pump low flow monitoring function.

NOTE: The no-flow power curve characterization shall be done after setting the motor control type.

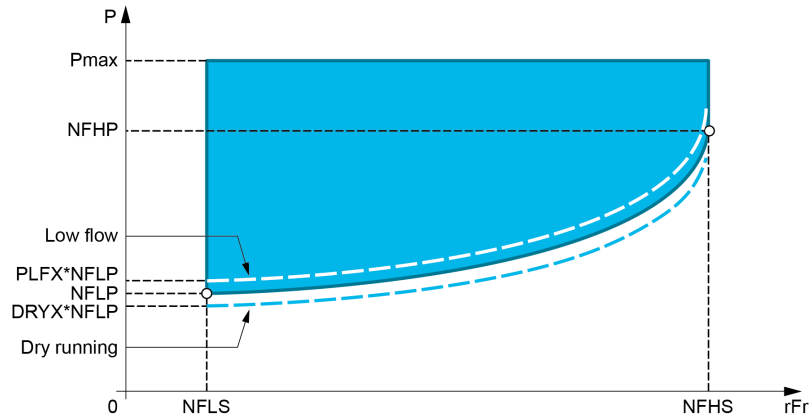

In case of dry-run conditions, this function will:

- Trigger a warning **[Drive Running Warning]** *dr YR* if the dry-run condition is present.
- Trigger an error **[Dry Run Error]** *dr YF* if the dry-run condition is present for a time longer than **[DryRun Error Delay]** *dr Yd*. After the error has been triggered, even if the detected error has been cleared, it is not possible to restart the pump before the end of the **[DryRun Restart Delay]** *dr Yr*.

NOTE: The detected error is not saved in case of a drive power OFF.

[DryRun Mode] *dr YN*

Dry-run mode.

Setting	Code / Value	Description
[No]	<i>no</i>	Not activated Factory setting
[Switch]	<i>SWt</i>	Using sensor switch
[Power]	<i>PWr</i>	Using the sensorless estimation

[Switch Select] *dr YW*★

Dry-run switches select.

This parameter can be accessed if **[DryRun Mode]** *dr YN* is set to **[Switch]** *SWt*.

Setting	Code / Value	Description
[No]	<i>no</i>	Not assigned Factory setting
[DI1]...[DI6]	<i>L 1 1...L 1 6</i>	Digital input DI1...DI6
[DI11]...[DI16]	<i>L 1 1 1... L 1 1 6</i>	Digital input DI11...DI16, if VW3A3203 I/O extension module has been inserted
[DI1 (Low level)]...[DI6 (Low level)]	<i>L 1 1 L...L 6 L</i>	Digital input DI1...DI6 used at low level
[DI11 (Low level)]...[DI16 (Low level)]	<i>L 1 1 1 L... L 1 1 6 L</i>	Digital input DI11...DI16 used at low level if VW3A3203 I/O extension module has been inserted

[Power Estim Value] P r W ★

Motor mechanical power estimation

This parameter can be accessed if **[DryRun Mode] d r Y N** is set to **[Power] P w r**.

Setting	Description
-327.67...327.67 kW	Setting range Factory setting: _

[Low Power] n F L P ★

No-flow low power.

This parameter can be accessed if **[DryRun Mode] d r Y N** is set to **[Power] P w r**.

Setting ()	Description
0.00...327.67 kW	Setting range Factory setting: 0.00 kW

[Low Speed] n F L S ★

No-flow low speed.

This parameter can be accessed if **[DryRun Mode] d r Y N** is set to **[Power] P w r**.

Setting ()	Description
0.0...500.0 Hz	Setting range Factory setting: 0.0 Hz

[High Power] n F H P ★

No-flow high power.

This parameter can be accessed if **[DryRun Mode] d r Y N** is set to **[Power] P w r**.

Setting ()	Description
0.00...327.67 kW	Setting range Factory setting: 0.00 kW

[High Speed] n F H S ★

No-flow high speed.

This parameter can be accessed if **[DryRun Mode] d r Y N** is set to **[Power] P w r**.

Setting 	Description
0.0...500.0 Hz	Setting range Factory setting: 0.0 Hz

[Dry Run Factor] *dr Y X* ★

Dry-run factor.

This parameter can be accessed if **[DryRun Mode]** *dr Y N* is set to **[Power]** *Pwr*.

Setting 	Description
0...100%	Setting range Factory setting: 70%

[DryRun Error Delay] *dr Y d* ★

Dry run detected error delay.

This parameter can be accessed if **[DryRun Mode]** *dr Y N* is not set to **[No]** *no*.

Setting 	Description
0...3,600 s	Setting range Factory setting: 5 s

[DryRun Restart Delay] *dr Y r* ★

Dry run detected error restart.

This parameter can be accessed if **[DryRun Mode]** *dr Y N* is not set to **[No]** *no*.

Setting 	Description
10...3,600 s	Setting range Factory setting: 60 s

[Pump monitoring] - [Pump low flow Monit]

[Pump low flow Monit] *PLF* - Menu

Access

[Complete settings] → [Pump monitoring] → [Pump low flow Monit]

About This Menu

The main consequence of running in low flow pump area is an increase of pump temperature as the pump is cooled by the liquid flow.

In addition, the low flow area is not a good working area from energy efficiency point of view.

No flow or low flow could be caused by:

- The verify valve at the discharge is closed.
- Issue on the pipe at the discharge (blocked pipes, ...).

This function helps to prevent the pump from being damaged by working at no or low flow.

The monitoring can be carried out with different methods using or not sensors and whether the system is mono or multi-pump.

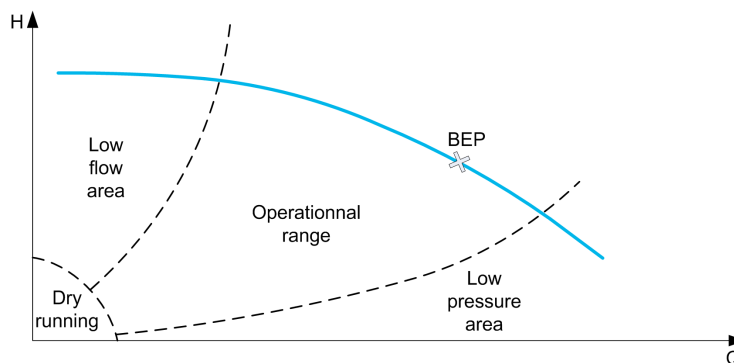

This function helps to detect probable no or low flow situation with different methods:

- Using a flow switch that indicates directly low flow condition: this method can be used only in mono-pump system or if the flow switch is connected on protected pump.

NOTE: It is recommended to use a flow switch that is open in case of a low flow and to use a digital input active at low level (DlxL). This allows you to stop the pump in case of a broken wire of the flow switch.
- Using a flow sensor and comparing the actual flow value to a given threshold:
 - This method can be used only in mono-pump system or if the flow sensor is connected on protected pump.
 - All data related to the selected input shall be configured according to the sensor (Type, minimum, and maximum process value, scaling, ...).
- Using a flow sensor and comparing the actual flow value to "Low flow system curve" QN characteristic:
 - This method can be used only in mono-pump system or if the flow sensor is connected on protected pump.
 - All data related to the selected input shall be configured according to the sensor (Type, minimum, and maximum process value, scaling, ...).

- Using Power/Speed estimation and comparing pump working point to "No Flow" Power characteristic:
 - Entering two [Speed; Power] points is required, first point in No Flow area (at Low speed point LSP), second point in high-speed area (At high-speed point HSP).
 - This method is not recommended in case of flat PQ curve.

Low flow monitoring is activated only after **[PumpLF ActivDelay] P L F A** after the pump has been started in order to disable the monitoring function during start operation.

Once a low flow condition is detected, a warning **[Low Flow Warning] L F W** is raised. Warning is automatically cleared when drive is stopped.

If the condition continues for longer than the configured **[PumpLF Error Delay] P L F d** delay, a detected error is raised and the drive reacts according to the configured **[PumpLF Error Resp] P L F b** error response. The monitoring is active even during the deceleration phase. It is recommended to set a greater delay than the complete deceleration sequence.

After error has been detected, it is maintained during **[PumpLF Restart Delay] P L F r** even if the warning has been reset.

NOTE: the drive restarts without delay if it is powered-off and on (restart delay is not saved). During the setup of the function, it is necessary to perform measurements at no flow but with water in the system.

[PumpLF Monitoring] P L F M

Pump low flow monitoring mode.

Setting	Code / Value	Description
[Not Configured]	n o	Not configured Factory setting
[Switch]	5 w	Using flow switch
[Flow]	9	Low flow is detected using fixed flow threshold
[Flow vs Speed]	9 n	Low flow is detected using flow vs speed
[No Flow power]	n F	Low flow is detected using no flow power characteristic

[PumpLF DI Assign] P L F W★

Pump low flow no flow switch selection.

This parameter can be accessed if **[PumpLF Monitoring] P L F M** is set to **[Switch] 5 w**.

Setting	Code / Value	Description
[Not Assigned]	n o	Not assigned Factory setting
[DI1]...[DI6]	L , I ... L , 6	Digital input DI1...DI6
[DI11]...[DI16]	L , I I ... L , I 6	Digital input DI11...DI16 if VW3A3203 I/O extension module has been inserted

[Pump Flow Assign.] F 5 2 A★

Pump flow sensor assignment.

This parameter can be accessed if **[PumpLF Monitoring]** *P L F Π* is set to **[Flow]** *9* or to **[Flow vs Speed]** *9 n*.

Setting	Code / Value	Description
[Not Configured]	<i>n a</i>	Not assigned Factory setting
[AI1]...[AI3]	<i>R , 1...R , 3</i>	Analog input AI1...AI3
[AI4]...[AI5]	<i>R , 4...R , 5</i>	Analog input AI4...AI5 if VW3A3203 I/O extension module has been inserted
[AI Virtual 1]... [AI Virtual 3]	<i>R , V 1... R , V 3</i>	Virtual analogic input 1...3
[Di5 PulseInput Assignment]... [Di6 PulseInput Assignment]	<i>P , 5...P , 6</i>	Digital input DI5...DI6 used as pulse input
[Est. Pump Flow]	<i>S L P F</i>	Sensor less estimated flow
NOTE: For sensor configuration, refer to section [Sensors assignment] , page 200.		

[Pump low flow Monit] $P L F$ - Menu

Access

[Complete settings] \rightarrow [Pump monitoring] \rightarrow [Pump low flow Monit]

About This Menu

During the setup of the function, it is necessary to perform measurements at no or low flow but always with water in the system.

[PumpLF Min Level] $P L F L$ ★

Pump low flow minimum flow level.

This parameter can be accessed if [PumpLF Monitoring] $P L F \Pi$ is set to [Flow] η or [Flow vs Speed] $\eta \Pi$.

Setting \odot	Description
0...32,767	Setting range according to [Flow rate unit] $S u F r$. Factory setting: 0

[Power Estim Value] $\square P r W$ ★

Motor mechanical power estimation. It can be used to set [Low Power] $\Pi F L P$ and [High Power] $\Pi F H P$ values.

This parameter can be accessed if [PumpLF Monitoring] $P L F \Pi$ is set to [No Flow Power] ΠF .

Setting	Description
According to drive rating	Setting range Factory setting: _

[Low Speed] $\Pi F L S$ ★

No flow low speed.

This parameter can be accessed if [PumpLF Monitoring] $P L F \Pi$ is set to [No Flow Power] ΠF .

Setting \odot	Description
0.0...500.0 Hz	Setting range Factory setting: 0.0 Hz

[High Speed] $\Pi F H S$ ★

No flow high speed.

This parameter can be accessed if [PumpLF Monitoring] $P L F \Pi$ is set to [No Flow Power] ΠF .

Setting 	Description
0.0...500.0 Hz	Setting range Factory setting: 0.0 Hz

[Low Power] *n F L P*★

No flow low power.

This parameter can be accessed if **[PumpLF Monitoring]** *P L F Π* is set to **[No Flow Power]** *n F*.

Setting 	Description
0...32,767	Setting range Factory setting: 0

[High Power] *n F H P*★

No flow high power.

This parameter can be accessed if **[PumpLF Monitoring]** *P L F Π* is set to **[No Flow Power]** *n F*.

Setting 	Description
0...32,767	Setting range Factory setting: 0

[PumpLF Power Factor] *P L F X*★

Pump low flow power factor.

This parameter can be accessed if **[PumpLF Monitoring]** *P L F Π* is set to **[No Flow Power]** *n F*.

Setting 	Description
100...500%	Setting range Factory setting: 110%

[PumpLF ActivDelay] *P L F A*★

Pump low flow monitoring activation delay after the pump has been started.

This parameter can be accessed if **[PumpLF Monitoring]** *P L F Π* is not set to **[No]** *n o*.

Setting 	Description
0...3,600 s	Setting range Factory setting: 10 s

[PumpLF Error Delay] *P L F d*★

Pump low flow detected error delay.

This parameter can be accessed if **[PumpLF Monitoring] *P L F n*** is not set to **[No] *n o***.

Setting 	Description
0...3,600 s	Setting range Factory setting: 10 s

[PumpLF Error Resp] *P L F b*★

Pump low flow monitoring function response to a detected error.

This parameter can be accessed if **[PumpLF Monitoring] *P L F n*** is not set to **[No] *n o***.

Setting	Code / Value	Description
[Ignore]	<i>n o</i>	Detected error ignored
[Freewheel Stop]	<i>y e s</i>	Freewheel stop Factory setting
[Per STT]	<i>s t t</i>	Stop according to [Type of stop] <i>S t t</i> parameter but without an error triggered after stop
[Fallback Speed]	<i>l f f</i>	Change to fallback speed, maintained as long as the detected error persists and the run command has not been removed ⁽¹⁾
[Ramp stop]	<i>r n p</i>	Stop on ramp
¹ Because, in this case, the detected error does not trigger a stop, it is recommended to assign a relay or logic output to its indication.		

[Fallback Speed] *L F F*★

Fall back speed.

Setting	Description
0.0...500.0 Hz	Setting range Factory setting: 0.0 Hz

[PumpLF Restart Delay] *P L F r*★

Pump low flow restart delay.

This parameter can be accessed if **[PumpLF Monitoring] *P L F n*** is not set to **[No] *n o***.

Setting 	Description
0...3,600 s	Setting range Factory setting: 0 s

[Pump monitoring] - [Thermal monitoring]

[Thermal monitoring] P P - Menu

Access

[Complete settings] → [Pump monitoring] → [Thermal monitoring]

About This Menu

Identical to [Thermal monitoring] P P - Menu , page 165.

[Pump monitoring] - [Inlet pressure monitoring]

[Inlet pressure monitoring] , P P - Menu

Access

[Complete settings] → [Pump monitoring] → [Inlet pressure monitoring]

About This Menu

This function helps to detect an inlet low-pressure situation.

This monitoring function is at station level and not a pump level only.

This function requires a pressure sensor to monitor the inlet pressure of the system.

In case of low inlet pressure situation, this function:

- Triggers a warning and reduces the outlet pressure set point within a predefined range in order to maintain the inlet pressure at an acceptable level. The inlet pressure compensation applies only to pressure controlled application.
- Triggers a detected error signal if, despite of this pressure set point reduction, the inlet pressure feedback is less than the minimum acceptable value configured.

The inlet pressure monitoring function can be used for mono-pump or multi-pump stations.

This is an example of a station architecture:

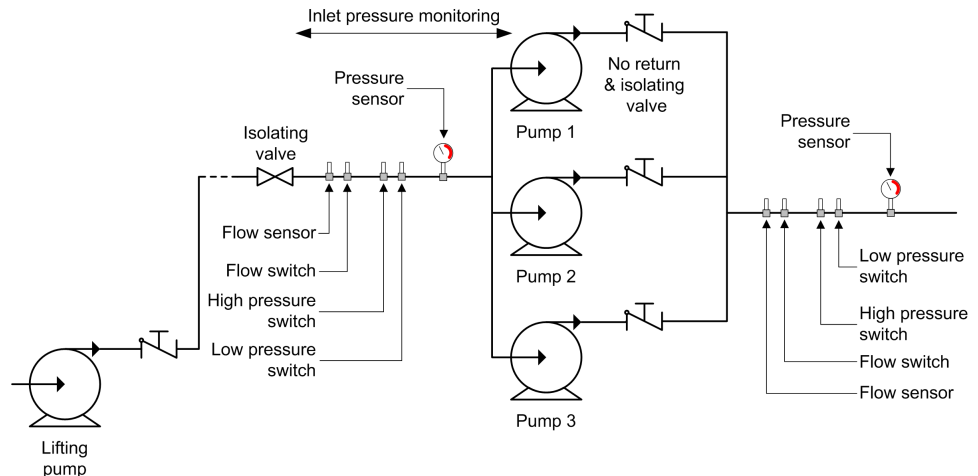

Monitoring Diagram

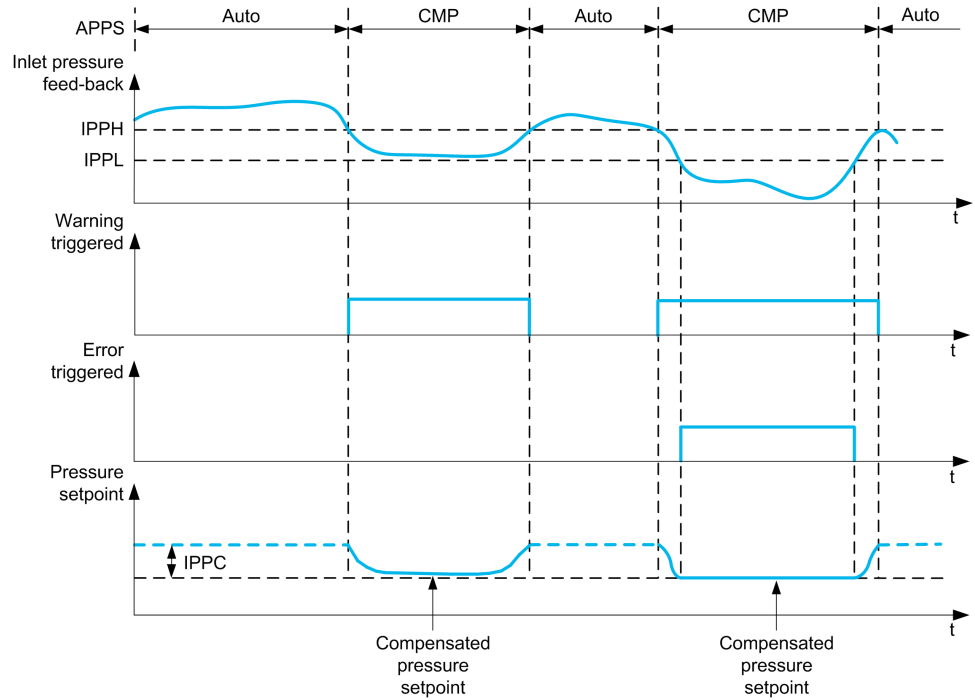

When the inlet pressure feedback is lower than **[InletPres High Thd]**, *IPPH* or **[InletPres DI assign]**, *IPPW* is active, a warning **[InletPres Warning]**, *IPPA* is triggered. In case of a pressure controlled application, the pressure set point is reduced according to **[InletPres Max Comp]**, *IPPC*.

When the inlet pressure feedback is less than **[InletPres Low Thd]**, *IPPL* or **[InletPres DI assign]**, *IPPW* is active for a delay longer than **[InletPresError Delay]**, *IPPD*, a detected error **[Inlet Pressure Error]**, *IPPE* is triggered. The application follows the **[InletPresErrorResp]**, *IPPEB* defined behavior.

[InletPres Monitoring], *IPPI*

Inlet pressure monitoring mode.

Setting	Code / Value	Description
[No]	<i>no</i>	Not activated Factory setting
[Warning]	<i>ALARP</i>	Warning monitoring activated
[Compensation]	<i>CCPP</i>	Warning and compensation activated

[InletPres DI Assign], *IPPW*★

Low inlet pressure switch source.

This parameter can be accessed if **[InletPres Monitoring]**, *IPPI* is not set to **[No]**, *no*.

Setting	Code / Value	Description
[Not Assigned]	<i>no</i>	Not assigned Factory setting
[DI1]...[DI6]	<i>L1...L6</i>	Digital input DI1...DI6

Setting	Code / Value	Description
[DI11]...[DI16]	L 1 1 ... L 1 6	Digital input DI11...DI16 if VW3A3203 I/O extension module has been inserted
[DI1 (Low level)]...[DI6 (Low level)]	L 1 L ... L 6 L	Digital input DI1...DI6 used at low level if VW3A3203 I/O extension module has been inserted.
[DI11 (Low level)]...[DI16 (Low level)]	L 1 1 L ... L 1 6 L	Digital input DI11...DI16 used at low level if VW3A3203 I/O extension module has been inserted.

[InletPres Assign] P 5 1 A★

Inlet pressure sensor assignment.

This parameter can be accessed if [InletPres Monitoring] , P P 1 is not set to [No] n o .

Setting	Code / Value	Description
[Not Configured]	n o	Not assigned Factory setting
[AI1]...[AI3]	A 1 1 ... A 1 3	Analog input AI1...AI3
[AI4]...[AI5]	A 1 4 ... A 1 5	Analog input AI4...AI5 if VW3A3203 I/O extension module has been inserted
[AI Virtual 1]... [AI Virtual 3]	A 1 V 1 ... A 1 V 3	Virtual analogic input 1...3
NOTE: For sensor configuration, refer to section [Sensors assignment] , page 200.		

[Inlet pressure monitoring] , P P - Menu

Access

[Complete settings] → [Pump monitoring] → [Inlet pressure monitoring]

[InletPres High Thd] , P P H★

Inlet pressure monitoring high/acceptable pressure.

This parameter can be accessed if [InletPres Monitoring] , P P Π is not set to [No] n o .

Setting ()	Description
-32,767...32,767	Setting range according to [P sensor unit] S u P r Factory setting: 0

[InletPres Low Thd] , P P L★

Inlet pressure monitoring low/minimum pressure.

This parameter can be accessed if [InletPres Monitoring] , P P Π is not set to [No] n o .

Setting ()	Description
-32,767...32,767	Setting range according to [P sensor unit] S u P r Factory setting: 0

[InletPres Max Comp] , P P C★

Inlet pressure monitoring max compensation.

This parameter can be accessed if [InletPres Monitoring] , P P Π is set to [Compensation] C o Π P .

Setting ()	Description
0...32,768	Setting range according to [P sensor unit] S u P r Factory setting: 0

[InletPresError Delay] , P P d★

Inlet pressure monitoring time

This parameter can be accessed if:

- [InletPres DI Assign] , P P W is not set to [Not Configured] n o , or
- [InletPres Assign] P S I R is not set to [Not Configured] n o .

Setting ()	Description
0...3,600 s	Factory setting: 0 s

[InletPresError Resp] , P P b ★

Pressure monitoring function response to a detected error.

This parameter can be accessed if **[InletPres Monitoring] , P P n** is not set to **[No] n o**.

Setting	Code / Value	Description
[Ignore]	n o	Detected error ignored
[Freewheel Stop]	Y E S	Freewheel stop
[Per STT]	5 E E	Stop according to [Type of stop] 5 E E parameter but without an error triggered after stop
[Fallback Speed]	L F F	Change to fallback speed, maintained as long as the detected error persists and the command has not been removed ⁽¹⁾
[Ramp stop]	r n P	Stop on ramp Factory setting

[Fallback Speed] L F F ★

Fall back speed.

This parameter can be accessed if **[OutPresError Resp] o P P b** is set to **[Fallback Speed] L F F**.

Setting	Description
0.0...500.0 Hz	Setting range Factory setting: 0.0 Hz

[Pump monitoring] - [Outlet pressure monitoring]

[Outlet pressure monitoring] \square PP - Menu

Access

[Complete settings] \rightarrow [Pump monitoring] \rightarrow [Outlet pressure monitoring]

About This Menu

This function detects an outlet high and low-pressure situation.

- It helps to prevent from high outlet pressure situations that can damage the hydraulic network (for example, pipe burst)
- It monitors low outlet pressure situations that can reflect damage on the hydraulic network (for example, pipe break)

This monitoring function is at the outlet station level.

The outlet pressure monitoring function requires a pressure sensor and/or a pressure switch to monitor the outlet pressure of the system.

- A high-pressure switch allows the activation of the high outlet pressure monitoring, according to the pressure switch specification.
- A pressure sensor allows the activation of both high and low outlet pressure monitoring, according to the **[OutPres Min Level] \square $PP L$** and **[OutPres Max Level] \square $PP H$** values.

Example of the station architecture:

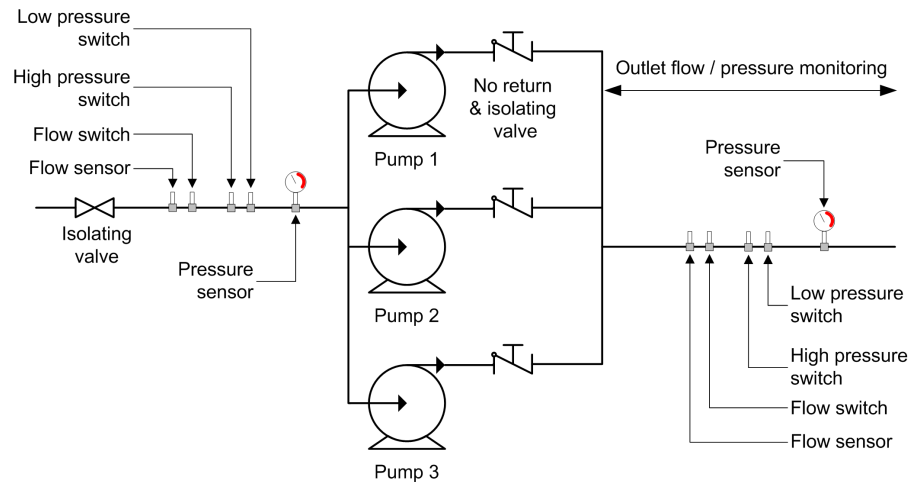

The outlet pressure monitoring function monitors the outlet pressure of the system.

- When a low-Pressure condition is present, a **[Low OutPres Warning] \square $PL R$** warning is triggered.
- When a high-Pressure condition is present, coming from the sensor, a **[High OutPres Warning] \square $PH R$** warning is triggered.
- When a high-Pressure condition is present, coming from the switch, a **[Switch OutPres Warning] \square $PS R$** warning is triggered.
- If the high-pressure condition remains for longer than **[OutPresError Delay] \square $PP d$** time, a detected **[Out Pressure High] \square $PH F$** error is triggered. The application follows the **[OutPresErrorResp] \square $PP b$** defined behavior.
- If the low-pressure condition remains for longer than **[OutPresError Delay] \square $PP d$** time, a detected **[Out Pressure Low] \square $PL F$** error is triggered. The application follows the **[OutPresError Delay] \square $PP d$** defined behavior.

NOTE:

- It is recommended to use a pressure switch that is open in case of high pressure and to use a digital input active at low level (DIxL). This allows stopping the pump in case of broken wire of the pressure switch.
- It is recommended to use a 4-20 mA pressure sensor and to enable the 4-20 mA loss function. This allows stopping the pump in case of broken wire of the pressure sensor.

[OutPres Monitoring] 5 5 5

Mode selection.

Setting	Code / Value	Description
[No]	n o	Inactive Factory setting
[Switch]	5 w	Activated on switch
[Sensor]	5 n 5 r	Activated on sensor
[Both]	b o t h	Activated on sensor and switch

[OutPres DI Assign] 5 5 w★

High outlet pressure switch source.

This parameter can be accessed if:

- **[OutPres Monitoring] 5 5 5** is set to **[Switch] 5 w**, or
- **[OutPres Monitoring] 5 5 5** is set to **[Both] b o t h**.

Setting	Code / Value	Description
[Not Assigned]	n o	Not assigned Factory setting
[DI1]...[DI6]	L 1 L ... L 6	Digital input DI1...DI6
[DI11]...[DI16]	L 1 1 ... L 1 6 L 1 5	Digital input DI11...DI16 if VW3A3203 I/O extension module has been inserted
[DI1 (Low level)]...[DI6 (Low level)]	L 1 L ... L 6 L	Digital input DI1...DI6 used at low level if VW3A3203 I/O extension module has been inserted.
[DI11 (Low level)]...[DI16 (Low level)]	L 1 1 L ... L 1 6 L	Digital input DI11...DI16 used at low level if VW3A3203 I/O extension module has been inserted.

[OutletPres Assign] 5 5 2 A★

Outlet pressure sensor assignment.

This parameter can be accessed if:

- **[OutPres Monitoring] 5 5 5** is set to **[Sensor] 5 n 5 r**, or
- **[OutPres Monitoring] 5 5 5** is set to **[Both] b o t h**.

Setting	Code / Value	Description
[Not Configured]	n o	Not assigned Factory setting
[AI1]...[AI3]	A 1 A ... A 3	Analog input AI1...AI3

Setting	Code / Value	Description
[AI4]...[AI5]	R , 4...R , 5	Analog input AI4...AI5 if VW3A3203 I/O extension module has been inserted
[AI Virtual 1]... [AI Virtual 3]	R , V 1... R , V 3	Virtual analogic input 1...3
NOTE: For sensor configuration, refer to section [Sensors assignment] , page 200.		

[Outlet pressure monitoring] \square P P - Menu

Access

[Complete settings] \rightarrow [Pump monitoring] \rightarrow [Outlet pressure monitoring]

[OutPres Min Level] \square P P L \star

Outlet pressure minimum level.

This parameter can be accessed if:

- [OutPres Monitoring] \square P P Π is set to [Sensor] $S n S r$, or
- [OutPres Monitoring] \square P P Π is set to [Both] $b o t H$.

Setting 	Description
0...32,767	Setting range, according to [P sensor unit] $S u P r$. Factory setting: 0

[OutPres Max Level] \square P P H \star

Outlet pressure maximum level.

This parameter can be accessed if:

- [OutPres Monitoring] \square P P Π is set to [Sensor] $S n S r$, or
- [OutPres Monitoring] \square P P Π is set to [Both] $b o t H$.

Setting 	Description
0...32,767	Setting range, according to [P sensor unit] $S u P r$. Factory setting: 0

[OutPresError Delay] \square P P d \star

Outlet pressure monitoring time.

This parameter can be accessed if [OutPres Monitoring] \square P P Π is not set to [No] $n o$.

Setting 	Description
0...3,600 s	Setting range Factory setting: 0 s

[OutPresError Resp] \square P P b \star

Outlet pressure fault config.

This parameter can be accessed if [OutPres Monitoring] \square P P Π is not set to [No] $n o$.

Setting	Code / Value	Description
[Ignore]	<i>n a</i>	Detected error ignored
[Freewheel Stop]	<i>y E 5</i>	Freewheel stop
[Per STT]	<i>5 5 5</i>	Stop according to [Type of stop] <i>5 5 5</i> parameter but without an error triggered after stop
[Fallback Speed]	<i>L F F</i>	Change to fallback speed, maintained as long as the detected error persists and the command has not been removed ⁽¹⁾
[Ramp stop]	<i>r P P</i>	Stop on ramp Factory setting

[Fallback Speed] *L F F* ★

Fall back speed.

This parameter can be accessed if [OutPresError Resp] *a P P b* is set to [Fallback Speed] *L F F*.

Setting	Description
0.0...500.0 Hz	Setting range Factory setting: 0.0 Hz

[Pump monitoring] - [High flow monitoring]

[High flow monitoring] *HFP* - Menu

Access

[Complete settings] → [Pump monitoring] → [High flow monitoring]

About This Menu

The high flow monitoring helps to detect abnormal outlet high flow situation:

- Works outside application flow capabilities
- Helps to detect pipe burst

This monitoring function is at outlet station level. This function requires a flow sensor to monitor the outlet flow of the system.

This is an example of a station architecture:

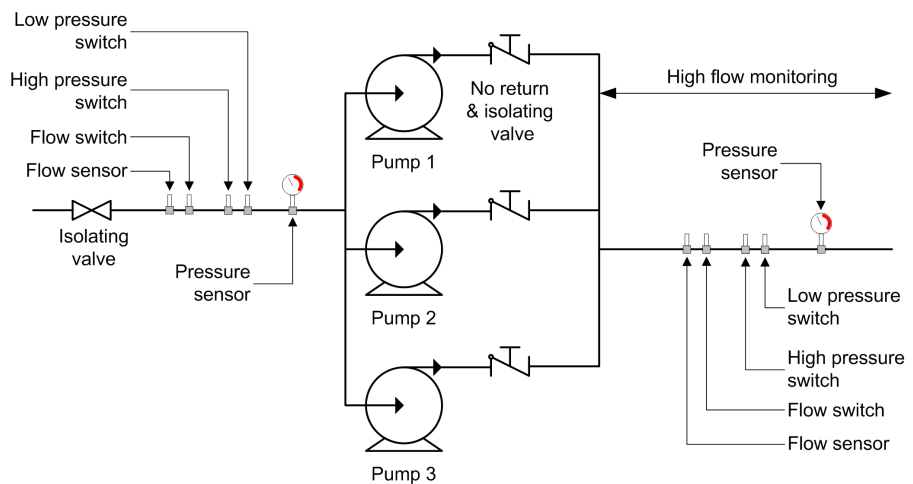

High flow monitoring function monitors the outlet flow of the system:

- When the outlet flow feedback is higher than **[HighFlow MaxLevel] *HFP L***, a warning **[High Flow Warning] *HFP R*** is triggered. The application does not stop.
- If the outlet flow feedback remains higher than **[HighFlow MaxLevel] *HFP L*** for longer than **[HighFlowError Delay] *HFP d*** time, a detected error **[High Flow Error] *HFP F*** is triggered. The application follows the **[HighFlowErrorResp] *HFP b*** defined behavior.

If a high flow situation is detected in a multi-pump system, all the pumps stop.

[HighFlow Activation] *HFP n*

Mode selection.

Setting	Code / Value	Description
[No]	<i>n o</i>	Function disabled Factory setting
[YES]	<i>y e s</i>	Function enabled

[Inst. Flow Assign.] F 5 I A★

Installation flow sensor assignment.

This parameter can be accessed if **[HighFlow Activation] H F P A** is not set to **[No] n o**.

Setting	Code / Value	Description
[Not Configured]	<i>n o</i>	Not assigned Factory setting
[AI1]...[AI3]	<i>A , 1...A , 3</i>	Analog input AI1...AI3
[AI4]...[AI5]	<i>A , 4...A , 5</i>	Analog input AI4...AI5 if VW3A3203 I/O extension module has been inserted
[AI Virtual 1]... [AI Virtual 3]	<i>A , V 1... A , V 3</i>	Virtual analogic input 1...3
[Di5 PulseInput Assignment]... [Di6 PulseInput Assignment]	<i>P , 5...P , 6</i>	Digital input DI5...DI6 used as pulse input
[Est. Pump Flow]	<i>S L P F</i>	Sensor less estimated flow
[Est. System Flow]	<i>S L S F</i>	Estimated system flow This selection is only possible if [Pump System Archit] P P S A is set to [Multi Drives] n V S d or [Multi Masters] n V S d r NOTE: To use this selection, all the pump characteristics of the system must be configured.
NOTE: For sensor configuration, refer to section [Sensors assignment] , page 200.		

[High flow monitoring] *H F P -* Menu

Access

[Complete settings] → [Pump monitoring] → [High flow monitoring]

About This Menu

Following parameters can be accessed if [HighFlow Activation] *H F P Π* is not set to [No] *n o*.

[HighFlow MaxLevel] *H F P L* ★

High flow max level.

Setting 	Description
0...32,767	Setting range, according to [Flow rate unit] <i>S u F r</i> Factory setting: 32767

[HighFlowError Delay] *H F P d* ★

High flow delay.

Setting 	Description
0...3,600 s	Setting range Factory setting: 10 s

[HighFlowError Resp] *H F P b* ★

High flow monitoring function response to a detected error.

Setting	Code / Value	Description
[Ignore]	<i>n o</i>	Detected error ignored
[Freewheel Stop]	<i>Y E S</i>	Freewheel stop
[Per STT]	<i>S E L</i>	Stop according to [Type of stop] <i>S E L</i> parameter but without an error triggered after stop
[Fallback Speed]	<i>L F F</i>	Change to fallback speed, maintained as long as the detected error persists and the command has not been removed ⁽¹⁾
[Ramp stop]	<i>r Π P</i>	Stop on ramp Factory setting

[Fallback Speed] *L F F* ★

Fall back speed.

Setting	Description
0.0...500.0 Hz	Setting range Factory setting: 0.0 Hz

[Fan] - [PID controller]

[PID Controller] *P i d -* Menu

Access

[Complete settings] → [Fan] → [PID Controller]

About This Menu

Identical to [PID Controller] *P i d -* Menu , page 306.

[Fan] - [Feedback monitoring]

[Feedback monitoring] *F K Π -* Menu

Access

[Complete settings] → [Fan] → [Feedback monitoring]

About This Menu

Identical to [Feedback monitoring] *F K Π -* Menu , page 343.

[Fan] - [Jump frequency]

[Jump frequency] JUF - Menu

Access

[Complete settings] → [Fan] → [Jump frequency]

About This Menu

This function helps to prevent prolonged operation within an adjustable range around the regulated frequency.

This function can be used to help prevent reaching a frequency, which could cause resonance. Setting the parameter to 0 disables the function.

The following figure is an example of the jump frequency function with one skip frequency defined by [Skip Frequency] JPF:

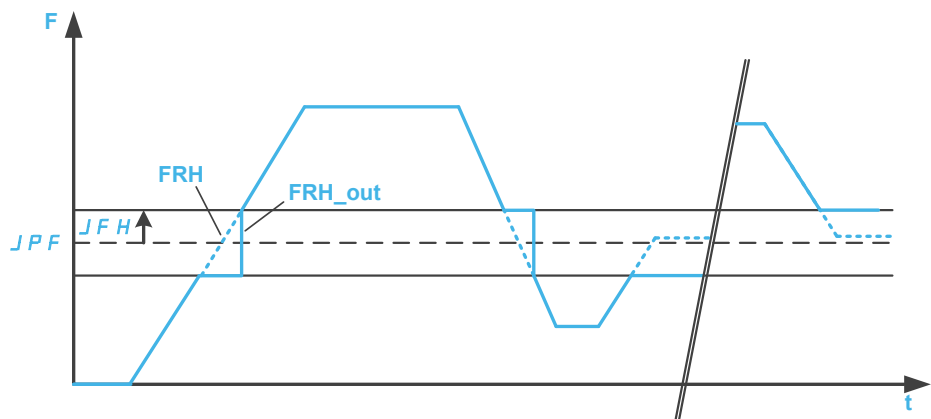

F Frequency

t time

JPF [Skip frequency]

JFH [Skip.Freq.Hysteresis]

FRH [Pre-Ramp Ref Freq]

FRH_out [Pre-Ramp Ref Freq] after the jump frequency function

[Skip Frequency] JPF

Jump frequency.

Setting ()	Description
0.0...500.0 Hz	Setting range Factory setting: 0.0 Hz

[Skip Frequency 2] JF2

Jump frequency 2.

Setting ()	Description
0.0...500.0 Hz	Setting range Factory setting: 0.0 Hz

[3rd Skip Frequency] *JF3*

Jump frequency 3.

Setting ()	Description
0.0...500.0 Hz	Setting range Factory setting: 0.0 Hz

[Skip.Freq.Hysteresis] *JFH*★

Jump frequency bandwidth.

This parameter can be accessed if at least one skip frequency *JPF*, *JF2*, or *JF3* is different from 0.

Skip frequency range: between $JPF - JFH$ and $JPF + JFH$ for example.

This adjustment is common to the 3 frequencies *JPF*, *JF2*, *JF3*.

Setting ()	Description
0.1...10.0 Hz	Setting range Factory setting: 1.0 Hz

[Fan]

[Fan] C 5 F A - Menu

Access

[Complete settings] → [Fan]

[Disable Error Detect] *INH*★

Disable error detection.

In rare cases, the monitoring functions of the device may be unwanted because they impede the purpose of the application. A typical example is a smoke extractor fan operating as a part of a fire protection system. If a fire occurs, the smoke extractor fan should operate as long as possible, even if, for example, the permissible ambient temperature of the device is exceeded. In such applications, damage to or destruction of the device may be acceptable as collateral damage, for example, to keep other damage from occurring whose hazard potential is assessed to be more severe.

A parameter is provided to disable certain monitoring functions in such applications so that automatic error detection and automatic error responses of the device are no longer active. You must implement alternative monitoring functions for disabled monitoring functions that allow operators and/or master control systems to adequately respond to conditions which correspond to detected errors. For example, if overtemperature monitoring of the device is disabled, the device of a smoke extractor fan may itself cause a fire if errors go undetected. An overtemperature condition can be, for example, signaled in a control room without the device being stopped immediately and automatically by its internal monitoring functions.

⚠ DANGER

ERROR DETECTION FUNCTIONS DISABLED, NO ERROR DETECTION

- Only use this parameter after a thorough risk assessment in compliance with all regulations and standards that apply to the device and to the application.
- Implement alternative monitoring functions for disabled monitoring functions that do not trigger automatic error responses of the device, but allow for adequate, equivalent responses by other means in compliance with all applicable regulations and standards as well as the risk assessment.
- Commission and test the system with the monitoring functions enabled.
- During commissioning, verify that the device and the system operate as intended by performing tests and simulations in a controlled environment under controlled conditions.

Failure to follow these instructions will result in death or serious injury.

This parameter can be accessed if [Access Level] *L R C* is set to [Expert] *E P r*.

If the assigned input or bit state is:

- 0: error detection is enabled.
- 1: error detection is disabled.

Current errors are cleared on a rising edge from 0 to 1 of the assigned input or bit.

Detection of following errors can be disabled: ACF1, ACF2, CFA, CFB, CFC, CHF, CNF, COF, COPF, DRYF, EPF1, EPF2, ETHF, FCF1, FCF2, FDR1, FDR2, FFDF, FWER, HFPF, IFA, IFB, IFC, IFD, INFB, INFV, IPPF, JAMF, LCHF, LCLF, LFF1, LFF2, LFF3, LFF4, LFF5, LKON, MDLF, MFF, MOF, MPDF, MPLF, OBF, OHF, OLC, OLF, OPF1, OPF2, OPHF, OPLF, OSF, P24C, PCPF, PFMF, PGLF, PHF, PLFF, SLF1, SLF2, SLF3, SOF, STF, T2CF, T3CF, T4CF, T5CF, TFA, TFB, TFC, TFD, TH2F, TH3F, TH4F, TH5F, TJF, TJF2, TNF, ULF, URF, USF.

Setting	Code / Value	Description
[Not Assigned]	n o	Not assigned Factory setting
[DI1]...[DI6]	L , 1...L , 6	Digital input DI1...DI6
[DI11]...[DI16]	L , 11... L , 16	Digital input DI11...DI16 if VW3A3203 I/O extension module has been inserted
[CD00]... [CD10]	C d 0 0... C d 1 0	Virtual digital input CMD.0...CMD.10 in [I/O profile] , o configuration
[CD11]... [CD15]	C d 1 1... C d 1 5	Virtual digital input CMD.11...CMD.15 regardless of configuration
[C101]... [C110]	C 1 0 1... C 1 1 0	Virtual digital input CMD1.01...CMD1.10 with integrated Modbus Serial in [I/O profile] , o configuration
[C111]... [C115]	C 1 1 1... C 1 1 5	Virtual digital input CMD1.11...CMD1.15 with integrated Modbus Serial regardless of configuration
[C201]... [C210]	C 2 0 1... C 2 1 0	Virtual digital input CMD2.01...CMD2.10 with CANopen® fieldbus module in [I/O profile] , o configuration
[C211]... [C215]	C 2 1 1... C 2 1 5	Virtual digital input CMD2.11...CMD2.15 with CANopen® fieldbus module regardless of configuration
[C301]... [C310]	C 3 0 1... C 3 1 0	Virtual digital input CMD3.01...CMD3.10 with a fieldbus module in [I/O profile] , o configuration
[C311]... [C315]	C 3 1 1... C 3 1 5	Virtual digital input CMD3.11...CMD3.15 with a fieldbus module regardless of configuration
[C501]... [C510]	C 5 0 1... C 5 1 0	Virtual digital input CMD5.01...CMD5.10 with integrated Ethernet in [I/O profile] , o configuration
[C511]... [C515]	C 5 1 1... C 5 1 5	Virtual digital input CMD5.11...CMD5.15 with integrated Ethernet regardless of configuration

[Auto Fault Reset] F E r

This function can be used to automatically perform individual or multiple Fault Resets. If the cause of the error that has triggered the transition to the operating state Fault disappears while this function is active, the drive resumes normal operation. While the Fault Reset attempts are performed automatically, the output signal "Operating state Fault" is not available. If the attempts to perform the Fault Reset are not successful, the drive remains in the operating state Fault and the output signal "Operating state Fault" becomes active.

▲ WARNING
UNANTICIPATED EQUIPMENT OPERATION
<ul style="list-style-type: none"> • Verify that activating this function does not result in unsafe conditions. • Verify that the fact that the output signal "Operating state Fault" is not available while this function is active does not result in unsafe conditions.
Failure to follow these instructions can result in death, serious injury, or equipment damage.

The drive error relay remains activated if this function is active. The speed reference and the operating direction must be maintained.

It is recommended to use 2-wire control ([2/3-wire control] E E E is set to [2-Wire Control] E E and [2-wire type] E E E is set to [Level] L E L).

If the restart has not taken place once the configurable time [Fault Reset Time] F E r has elapsed, the procedure is aborted and the drive remains locked until it is turned off and then on again.

The detected error codes, which permit this function, are listed.

Setting	Code / Value	Description
[No]	<i>n o</i>	Function inactive Factory setting
[Yes]	<i>Y E 5</i>	Automatic restart, after locking in error state, if the detected error has disappeared and the other operating conditions permit the restart. The restart is performed by a series of automatic attempts separated by increasingly longer waiting periods: 1 s, 5 s, 10 s, then 1 minute for the following attempts.

[Catch On Fly] *F L r*

Catch on the fly function assignment.

Used to enable a smooth restart if the run command is maintained after the following events:

- Loss of line supply or disconnection.
- Clearance of current detected error or automatic restart.
- Freewheel stop (a delay of 5 time the **[Rotor Time Const] *L r R*** is applied before taking the next run command into account).

The speed given by the drive resumes from the estimated speed of the motor at the time of the restart, then follows the ramp to the reference speed.

This function requires 2-wire level control.

When the function is operational, it activates at each run command, resulting in a slight delay of the current (0.5 s max).

[Catch On Fly] *F L r* is forced to **[No] *n o*** if **[Auto DC Injection] *A d C*** is set to **[Continuous] *C L***.

Setting	Code / Value	Description
[Not Configured]	<i>n o</i>	Function inactive. Factory setting
[Yes On Freewheel]	<i>Y E 5</i>	Function active only after freewheel stop.
[Yes Always]	<i>A L L</i>	Function active after all stop type

[Generic functions] - [Speed limits]

[Speed limits] 5 L 7 - Menu

Access

[Complete settings] → [Generic functions] → [Speed limits]

About This Menu

This function defines how the acceleration and deceleration are controlled during start and stop of the pump.

The pump working area is within the speed range **[Low Speed] L 5 P** - **[High Speed] H 5 P**.

The minimum speed is provided by the pump manufacturer according to the application.

Running below the minimum speed and/or starting the pump with a long acceleration ramp time has an impact on the lubrication of the seal, on the cooling of the impeller and the bearings.

A specific check-valve deceleration ramp is available to reduce any large variation of pressure that can generate an instability of the valve.

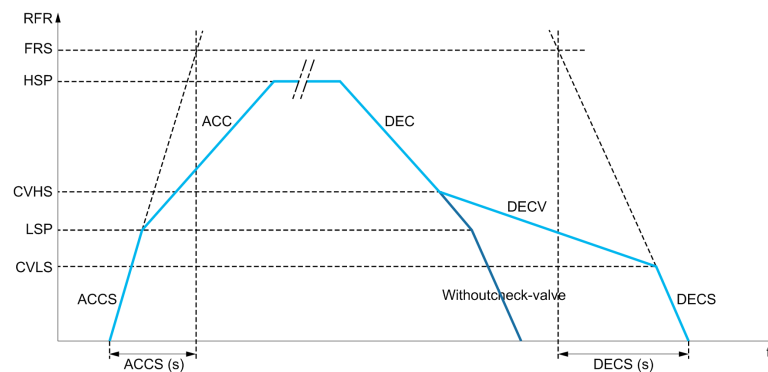

When the pump starts, the pump accelerates up to **[Low Speed] L 5 P** according to **[Start Accel Ramp] R C C 5**. When the pump speed is above **[Low Speed] L 5 P**, the pump acceleration and deceleration are managed according to **[Acceleration] R C C** and **[Deceleration] d E C** if no other function is activated.

When the pump stops:

- The pump decelerates down to **[Check Valve Spd 2] C V H 5** according to **[Deceleration] d E C**
- The pump decelerates from **[Check Valve Spd 2] C V H 5** to **[Check Valve Spd 1] C V L 5** according to **[Dec. Check Valve] d E C V**
- The pump decelerates from **[Check Valve Spd 1] C V L 5** to zero speed according to **[Deceleration on Stop] d E C 5**

If **[Start Accel Ramp] R C C 5 = 0**, the start ramp is ignored and **[Acceleration] R C C** is used to start the pump.

If **[Dec. Check Valve] d E C V = 0**, the check-valve ramp is ignored and is used to decelerate down to **[Low Speed] L 5 P**, then **[Deceleration on Stop] d E C 5** is used (see below).

If **[Deceleration on Stop] d E C 5 = 0**, the normal deceleration **[Deceleration] d E C** is used to stop the pump.

[Low Speed] *L 5 P*

Motor frequency at low speed.

Note: The setting of this parameter must not be modified during the learning phase in the vortex control , page 382 (i.e **[Curve learn mode] *V L L P*** is set to **[Learnt curve mode] *L E R r n***). If setting modified, it is recommended to restart the learning.

Setting ()	Description
0.0...500.0 Hz	Setting range Factory setting: 0 Hz

[High Speed] *H 5 P*

Motor frequency at high speed.

To help prevent **[Motor Overspeed] *S o F*** error, it is recommended to have **[Max Frequency] *L F r*** equal to or higher than 110% of **[High Speed] *H 5 P***.

Note: The setting of this parameter must not be modified during the learning phase in the vortex control , page 382 (i.e **[Curve learn mode] *V L L P*** is set to **[Learnt curve mode] *L E R r n***). If setting modified, it is recommended to restart the learning.

Setting ()	Description
0.0...500.0 Hz	Setting range Factory setting: 50.0 Hz

[Ref Freq Template] *b 5 P*

Low speed management (template).

This parameter defines how the speed reference is taken into account, for analog inputs and pulse input only. In the case of the PID controller, this is the PID output reference.

The limits are set by the **[Low speed] *L 5 P*** and **[High speed] *H 5 P*** parameters.

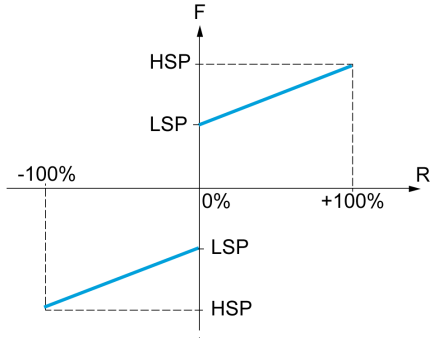
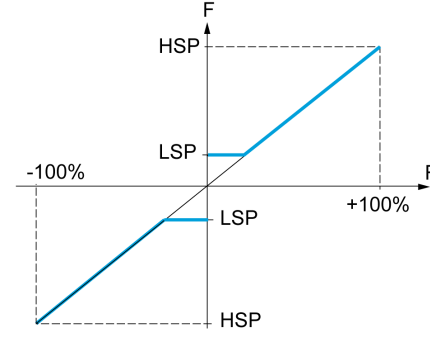
Setting ()	Code / Value	Description
[Standard]	b 5 d	 <p>F Frequency</p> <p>R Reference At reference = 0, the frequency = [Low speed] L 5 P</p> <p>Factory setting</p>
[Pedestal]	b L 5	 <p>F Frequency</p> <p>R Reference At reference = 0 to [Low speed] L 5 P, the frequency = [Low speed] L 5 P</p>

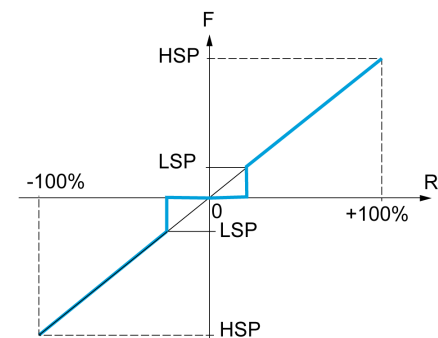
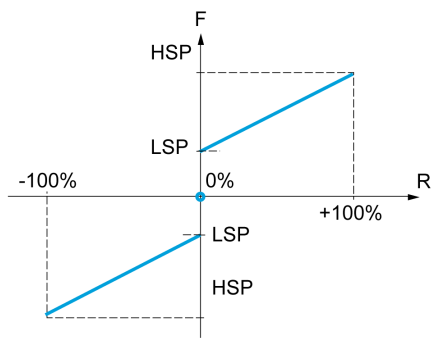
Setting ()	Code / Value	Description
[Deadband]	b n 5	 <p>F Frequency</p> <p>R Reference At reference = 0 to L S P the frequency = 0</p>
[Deadband at 0%]	b n 5 0	 <p>F Frequency</p> <p>R Reference This operation is the same as [Standard] b 5 d, except that in the following cases at zero reference, the frequency = 0: The signal is less than [Min value], which is greater than 0 (example: 1 Vdc on a 2–10 Vdc input). The signal is greater than [Min value], which is greater than [Max value] (example: 11 Vdc on a 10–0 Vdc input).</p> <p>If the input range is configured as “bidirectional”, the operation remains identical to [Standard] b 5 d.</p>

[Generic functions] - [Ramp]

[Ramp] \llcorner $\text{A} \cap \text{P}$ - Menu

Access

[Complete settings] \rightarrow [Generic functions] \rightarrow [Ramp]

[Ramp Type] \llcorner $\text{P} \llcorner$

Type of ramp.

Setting	Code / Value	Description
[Linear]	$\llcorner \cap$	Linear ramp Factory setting
[S-Ramp]	5	S ramp
[U-Ramp]	\cup	U ramp
[Customized]	$\llcorner \cup 5$	Customer ramp

[Ramp increment] $\cap \cap \llcorner$

This parameter is valid for [Acceleration] $\text{A} \llcorner \llcorner$, [Deceleration] $\text{d} \llcorner \llcorner$, [Acceleration 2] $\text{A} \llcorner \llcorner 2$ and [Deceleration 2] $\text{d} \llcorner \llcorner 2$.

Setting \cap	Code / Value	Description
[0.01]	$\cap . \cap \cap$	Ramp up to 99.99 seconds
[0.1]	$\cap . \cap$	Ramp up to 999.9 seconds Factory setting
[1]	\cap	Ramp up to 6,000 seconds

[Acceleration] $\text{A} \llcorner \llcorner$

Time to accelerate from 0 to the [Nominal Motor Freq] $\text{F} \llcorner 5$.

To have repeatability in ramps, the value of this parameter must be set according to the possibility of the application (for example, the inertia must be considered).

Setting \cap	Description
0.00...6,000.00 s ⁽¹⁾	Setting range Factory setting: 10.00 s
⁽¹⁾ Range 0.01 to 99.99 s or 0.1 to 999.9 s or 1 to 6,000 according to [Ramp increment] $\cap \cap \llcorner$	

[Deceleration] $\text{d} \llcorner \llcorner$

Time to decelerate from the [Nominal Motor Freq] $\text{F} \llcorner 5$ to 0.

To have repeatability in ramps, the value of this parameter must be set according to the possibility of the application (for example, the inertia must be considered).

Setting ()	Description
0.00...6,000.00 s ⁽¹⁾	Setting range Factory setting: 10.00 s
(1) Range 0.01 to 99.99 s or 0.1 to 999.9 s or 1 to 6,000 according to [Ramp increment] 1 0 0	

[Begin Acc round] 5 A 1 ★

Rounding of start of acceleration ramp as a percentage of the **[Acceleration]** A C C or **[Acceleration 2]** A C 2 ramp time.

This parameter can be accessed if the **[Ramp type]** r P E is set to **[Customized]** C u 5.

Setting ()	Description
0...100%	Setting range Factory setting: 10%

[End Acc round] 5 A 2 ★

Rounding of end of acceleration ramp as a percentage of the **[Acceleration]** A C C or **[Acceleration 2]** A C 2 ramp time.

This parameter can be accessed if the **[Ramp type]** r P E is set to **[Customized]** C u 5.

Setting ()	Description
0...(100 - [Begin Acc round] 5 A 1) %	Setting range Factory setting: 10%

[Begin Dec round] 5 A 3 ★

Rounding of start of deceleration ramp as a percentage of the **[Deceleration]** d E C or **[Deceleration 2]** d E 2 ramp time.

This parameter can be accessed if the **[Ramp type]** r P E is set to **[Customized]** C u 5.

Setting ()	Description
0...100%	Setting range Factory setting: 10%

[End Dec round] 5 A 4 ★

Rounding of end of deceleration ramp as a percentage of the **[Deceleration]** d E C or **[Deceleration 2]** d E 2 ramp time.

Can be set between 0 and (100% - **[Begin Dec round]** 5 A 3).

This parameter can be accessed if the **[Ramp type]** r P E is **[Customized]** C u 5.

Setting ()	Description
0...(100 - [Begin Dec round] 5 A 3) %	Setting range Factory setting: 10%

[Dec.Ramp Adapt] brA

Deceleration ramp adaptation.

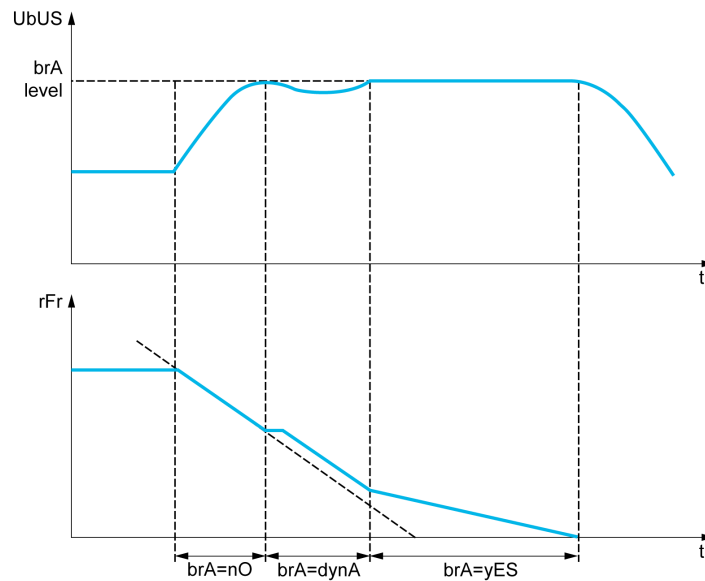

Activating this function automatically adapts the deceleration ramp, if this has been set at a too low value according to the inertia of the load, which can cause an overvoltage detected error.

The function is incompatible with applications requiring:

- Positioning on a ramp

NOTE: During generator mode with ATV6B0...Q6, if [Dec.Ramp Adapt] brA is equal to [Yes] yES, the drive may remain in current limitation state to stabilize the DC bus voltage.

Setting	Code / Value	Description
[No]	no	Function inactive
[Yes]	yES	Function active, for applications that do not require strong deceleration Factory setting
[High Torque]	dynA	Addition of a constant current flow component. The [High Torque] dynA selection appears depending on the rating of the drive and [Motor control type] 5 5 5. It enables stronger deceleration to be obtained than with [Yes] yES. Use comparative testing to determine your selection When [Dec.Ramp Adapt] brA is configured on [High torque] dynA, the dynamic performances for braking are improved by the addition of a current flow component. The aim is to increase the iron loss and magnetic energy stored in the motor.
<p>NOTE: [Dec.Ramp Adapt] brA if forced to [No] no if [Motor control type] 5 5 5 is set to [Reluctance Motor] 5 5 5 and [Dec.Ramp Adapt] brA was set to [High Torque] dynA.</p>		

[Braking Current Level] bdCL

Maximum braking current level.

This parameter modifies the maximum current level that can be reached during the adaptation of the braking deceleration. Increasing the maximum value increases the motor current loss via iron loss and magnetic energy stored in the motor.

It is expressed in % of nominal magnetizing current (**[Magnetizing current]** $i_d R$).

This parameter can be accessed if:

- **[Access Level]** $L R C$ is set to **[Expert]** $E P r$, and
- **[Dec. Ramp Adapt]** $b r R$ is set to **[High Torque]** $d Y n R$.

Setting	Code / Value	Description
[Auto]	$R u t o$	Automatic: it corresponds to 125 %. Factory setting.
0.1...500.0%		Settings range.

[Generic functions] - [Ramp switching]

[Ramp switching] *r P t* - Menu

Access

[Complete settings] → [Generic functions] → [Ramp switching]

[Ramp 2 Thd] *F r t*

Ramp 2 frequency threshold

The second ramp is switched if the value of **[Ramp 2 Thd] *F r t*** is not 0 (0 deactivates the function) and the output frequency is greater than **[Ramp 2 Thd] *F r t***.

Threshold ramp switching can be combined with **[Ramp Switch Assign] *r P 5*** switching as follows:

DI or Bit	Frequency	Ramp
0	< <i>F r t</i>	<i>R C C, d E C</i>
0	> <i>F r t</i>	<i>R C 2, d E 2</i>
1	< <i>F r t</i>	<i>R C 2, d E 2</i>
1	> <i>F r t</i>	<i>R C 2, d E 2</i>

Setting 	Description
0.0...500.0 Hz	Setting range Factory setting: 0.0 Hz

[Ramp Switch Assign] *r P 5*

Ramp switching.

Setting	Code / Value	Description
[Not Assigned]	<i>n o</i>	Not assigned Factory setting
[DI1]...[DI6]	<i>L , 1...L , 6</i>	Digital input DI1...DI6
[DI11]...[DI16]	<i>L , 11...L , 16</i>	Digital input DI11...DI16 if VW3A3203 I/O extension module has been inserted
[CD00]...[CD10]	<i>C d 0 0...C d 1 0</i>	Virtual digital input CMD.0...CMD.10 in [I/O profile] , o configuration
[CD11]...[CD15]	<i>C d 1 1...C d 1 5</i>	Virtual digital input CMD.11...CMD.15 regardless of configuration
[C101]...[C110]	<i>C 1 0 1...C 1 1 0</i>	Virtual digital input CMD1.01...CMD1.10 with integrated Modbus Serial in [I/O profile] , o configuration
[C111]...[C115]	<i>C 1 1 1...C 1 1 5</i>	Virtual digital input CMD1.11...CMD1.15 with integrated Modbus Serial regardless of configuration
[C201]...[C210]	<i>C 2 0 1...C 2 1 0</i>	Virtual digital input CMD2.01...CMD2.10 with CANopen® fieldbus module in [I/O profile] , o configuration
[C211]...[C215]	<i>C 2 1 1...C 2 1 5</i>	Virtual digital input CMD2.11...CMD2.15 with CANopen® fieldbus module regardless of configuration
[C301]...[C310]	<i>C 3 0 1...C 3 1 0</i>	Virtual digital input CMD3.01...CMD3.10 with a fieldbus module in [I/O profile] , o configuration

Setting	Code / Value	Description
[C311]... [C315]	C 3 1 1... C 3 1 5	Virtual digital input CMD3.11...CMD3.15 with a fieldbus module regardless of configuration
[C501]... [C510]	C 5 0 1... C 5 1 0	Virtual digital input CMD5.01...CMD5.10 with integrated Ethernet in [I/O profile] configuration
[C511]... [C515]	C 5 1 1... C 5 1 5	Virtual digital input CMD5.11...CMD5.15 with integrated Ethernet regardless of configuration

[Acceleration 2] A C 2 ★

Acceleration 2 ramp time.

Time to accelerate from 0 to the **[Nominal Motor Freq]** $F_r 5$. To have repeatability in ramps, the value of this parameter must be set according to the possibility of the application.

This parameter can be accessed if **[Ramp 2 Thd]** $F_r 4$ is greater than 0 or if **[Ramp Switch Assign]** $r P 5$ is assigned.

Setting ()	Description
0.0...6,000 s ⁽¹⁾	Setting range Factory setting: 5.0 s
(1) Range 0.01 to 99.99 s or 0.1 to 999.9 s or 1...6,000 s according to [Ramp increment] $r n r$.	

[Deceleration 2] D E 2 ★

Time to decelerate from the **[Nominal Motor Freq]** $F_r 5$ to 0. To have repeatability in ramps, the value of this parameter must be set according to the possibility of the application.

This parameter can be accessed if:

- **[Ramp 2 Thd]** $F_r 4$ is greater than 0, or
- **[Ramp Switch Assign]** $r P 5$ is assigned.

Setting ()	Description
0.0...6,000 s ⁽¹⁾	Setting range Factory setting: 5.0 s
(1) Range 0.01 to 99.99 s or 0.1 to 999.9 s or 1...6,000 s according to [Ramp increment] $r n r$.	

[Generic functions] - [Stop configuration]

[Stop configuration] 5 5 5 - Menu

Access

[Complete settings] → [Generic functions] → [Stop configuration]

About This Menu

NOTE: This function cannot be used with some other functions.

[Type of stop] 5 5 5

Normal stop mode.

Stop mode on disappearance of the run command or appearance of a stop command.

Setting	Code / Value	Description
[On Ramp]	r P P	Stop on ramp Factory setting
[Fast stop]	F 5 5	Fast stop
[Freewheel]	n 5 5	Freewheel stop
[DC injection]	d C ,	DC injection stop. Available if [Motor control type] 5 5 5 is not set to [SYN_U VC] 5 5 n u or [Reluctance Motor] 5 r v 5 .

[Freewheel stop] n 5 5

Freewheel stop.

The stop is activated when the input or the bit changes to 0. If the input returns to state 1 and the run command is still active, the motor will only restart if [2/3-wire control] 5 5 5 is set to [2-Wire Control] 2 5 5 and if [2-wire type] 5 5 5 is set to [Level] L E L or [Fwd priority] P F 0 . If not, a new run command must be sent.

Setting	Code / Value	Description
[Not Assigned]	n 0	Not assigned Factory setting
[CD00]... [CD10]	C d 0 0 ... C d 1 0	Virtual digital input CMD.0...CMD.10 in [I/O profile] , 0 configuration
[CD11]... [CD15]	C d 1 1 ... C d 1 5	Virtual digital input CMD.11...CMD.15 regardless of configuration
[C101]... [C110]	C 1 0 1 ... C 1 1 0	Virtual digital input CMD1.01...CMD1.10 with integrated Modbus Serial in [I/O profile] , 0 configuration
[C111]... [C115]	C 1 1 1 ... C 1 1 5	Virtual digital input CMD1.11...CMD1.15 with integrated Modbus Serial regardless of configuration
[C201]... [C210]	C 2 0 1 ... C 2 1 0	Virtual digital input CMD2.01...CMD2.10 with CANopen® fieldbus module in [I/O profile] , 0 configuration
[C211]... [C215]	C 2 1 1 ... C 2 1 5	Virtual digital input CMD2.11...CMD2.15 with CANopen® fieldbus module regardless of configuration
[C301]... [C310]	C 3 0 1 ... C 3 1 0	Virtual digital input CMD3.01...CMD3.10 with a fieldbus module in [I/O profile] , 0 configuration

Setting	Code / Value	Description
[C311]... [C315]	C 3 1 1... C 3 1 5	Virtual digital input CMD3.11...CMD3.15 with a fieldbus module regardless of configuration
[C501]... [C510]	C 5 0 1... C 5 1 0	Virtual digital input CMD5.01...CMD5.10 with integrated Ethernet Modbus TCP in [I/O profile] configuration
[C511]... [C515]	C 5 1 1... C 5 1 5	Virtual digital input CMD5.11...CMD5.15 with integrated Ethernet Modbus TCP regardless of configuration
[DI1 (Low level)]...[DI6 (Low level)]	L 1 L ... L 6 L	Digital input DI1...DI6 used at low level
[DI11 (Low level)]...[DI16 (Low level)]	L 1 1 L ... L 1 6 L	Digital input DI11...DI16 used at low level if VW3A3203 I/O extension module has been inserted
[DI52 (Low level)]...[DI59 (Low level)]	d 5 2 L ... d 5 9 L	Digital input DI52...DI59 (low level) NOTE: This selection can be accessed on ATV660 and ATV680 equipped with Cabinet IO.
[DI52 (High level)]... [DI59 (High level)]	d 5 2 H ... d 5 9 H	Cabinet high level digital inputs NOTE: This selection can be accessed on ATV660 and ATV680 equipped with Cabinet IO.

[Freewheel stop Thd] F F E ★

Freewheel stop threshold.

Speed threshold below which the motor switches to freewheel stop.

This parameter supports switching from a ramp stop or a fast stop to a freewheel stop below a low speed threshold.

This parameter can be accessed if:

- [Type of stop] S E E is set to [Fast stop] F 5 E or [On Ramp] r P P, and
- [Auto DC Injection] R d E is not configured.

Setting ()	Description
0.2...500.0 Hz	Setting range Factory setting: 0.2 Hz

[Fast stop Assign] F 5 E

Fast stop.

The stop is activated when the input changes to 0 or the bit changes to 1 (bit in [I/O profile] at 0).

If the input returns to state 1 and the run command is still active, the motor will only restart if [2/3-wire control] E C C is set to [2-Wire Control] 2 C and if [2-wire type] E C E is set to [Level] L E L or [Fwd priority] P F .

If not, a new run command must be sent.

NOTE: This function cannot be used with some other functions.

Setting	Code / Value	Description
[Not Assigned]	n o	Not assigned Factory setting
[CD00]... [CD10]	C d 0 0... C d 1 0	Virtual digital input CMD.0...CMD.10 in [I/O profile] configuration
[CD11]... [CD15]	C d 1 1... C d 1 5	Virtual digital input CMD.11...CMD.15 regardless of configuration

Setting	Code / Value	Description
[C101]... [C110]	C 1 0 1... C 1 1 0	Virtual digital input CMD1.01...CMD1.10 with integrated Modbus Serial in [I/O profile] , a configuration
[C111]... [C115]	C 1 1 1... C 1 1 5	Virtual digital input CMD1.11...CMD1.15 with integrated Modbus Serial regardless of configuration
[C201]... [C210]	C 2 0 1... C 2 1 0	Virtual digital input CMD2.01...CMD2.10 with CANopen® fieldbus module in [I/O profile] , a configuration
[C211]... [C215]	C 2 1 1... C 2 1 5	Virtual digital input CMD2.11...CMD2.15 with CANopen® fieldbus module regardless of configuration
[C301]... [C310]	C 3 0 1... C 3 1 0	Virtual digital input CMD3.01...CMD3.10 with a fieldbus module in [I/O profile] , a configuration
[C311]... [C315]	C 3 1 1... C 3 1 5	Virtual digital input CMD3.11...CMD3.15 with a fieldbus module regardless of configuration
[C501]... [C510]	C 5 0 1... C 5 1 0	Virtual digital input CMD5.01...CMD5.10 with integrated Ethernet Modbus TCP in [I/O profile] , a configuration
[C511]... [C515]	C 5 1 1... C 5 1 5	Virtual digital input CMD5.11...CMD5.15 with integrated Ethernet Modbus TCP regardless of configuration
[DI1 (Low level)]...[DI6 (Low level)]	L 1 L ... L 6 L	Digital input DI1...DI6 used at low level
[DI11 (Low level)]...[DI16 (Low level)]	L 1 1 L ... L 1 6 L	Digital input DI11...DI16 used at low level if VW3A3203 I/O extension module has been inserted

[Ramp Divider] d C F ★

Fast Stop deceleration ramp reduction coefficient.

The ramp that is enabled ([Deceleration] d E C or [Deceleration 2] d E 2) is then divided by this coefficient when stop requests are sent.

Value 0 corresponds to a minimum ramp time.

Setting ()	Description
0...10	Setting range Factory setting: 4

[DC Injection Assign] d C ,

DC injection brake assignment.

⚠ WARNING
<p>UNINTENDED MOVEMENT</p> <ul style="list-style-type: none"> Do not use DC injection to generate holding torque when the motor is at a standstill. Use a holding brake to keep the motor in the standstill position. <p>Failure to follow these instructions can result in death, serious injury, or equipment damage.</p>

This parameter can be accessed if [Motor control type] C E E is not set to [SYN_U VC] S Y n u or [Reluctance Motor] S r V C.

DC injection braking is initiated when the assigned input or bit changes to state 1.

If the input returns to state 0 and the run command is still active, the motor will only restart if [2/3-wire control] E C C is set to [2-Wire Control] 2 C and if [2-

wire type] 5 5 5 is set to **[Level] 5 5 5** or **[Fwd priority] P F 0**. If not, a new run command must be sent.

NOTE: This function cannot be used with some other functions.

Setting	Code / Value	Description
[Not Assigned]	n 0	Not assigned Factory setting
[DI1]...[DI6]	L , 1...L , 6	Digital input DI1...DI6
[DI11]...[DI16]	L , 11... L , 16	Digital input DI11...DI16 if VW3A3203 I/O extension module has been inserted
[CD00]... [CD10]	C d 0 0... C d 1 0	Virtual digital input CMD.0...CMD.10 in [I/O profile] , 0 configuration
[CD11]... [CD15]	C d 1 1... C d 1 5	Virtual digital input CMD.11...CMD.15 regardless of configuration
[C101]... [C110]	C 1 0 1... C 1 1 0	Virtual digital input CMD1.01...CMD1.10 with integrated Modbus Serial in [I/O profile] , 0 configuration
[C111]... [C115]	C 1 1 1... C 1 1 5	Virtual digital input CMD1.11...CMD1.15 with integrated Modbus Serial regardless of configuration
[C201]... [C210]	C 2 0 1... C 2 1 0	Virtual digital input CMD2.01...CMD2.10 with CANopen® fieldbus module in [I/O profile] , 0 configuration
[C211]... [C215]	C 2 1 1... C 2 1 5	Virtual digital input CMD2.11...CMD2.15 with CANopen® fieldbus module regardless of configuration
[C301]... [C310]	C 3 0 1... C 3 1 0	Virtual digital input CMD3.01...CMD3.10 with a fieldbus module in [I/O profile] , 0 configuration
[C311]... [C315]	C 3 1 1... C 3 1 5	Virtual digital input CMD3.11...CMD3.15 with a fieldbus module regardless of configuration
[C501]... [C510]	C 5 0 1... C 5 1 0	Virtual digital input CMD5.01...CMD5.10 with integrated Ethernet in [I/O profile] , 0 configuration
[C511]... [C515]	C 5 1 1... C 5 1 5	Virtual digital input CMD5.11...CMD5.15 with integrated Ethernet regardless of configuration

[DC inject. level 1] , d 1 ★

DC injection current.

NOTICE

OVERHEATING

Verify that the connected motor is properly rated for the DC injection current to be applied in terms of amount and time.

Failure to follow these instructions can result in equipment damage.

Level of DC injection braking current activated via digital input or selected as stop mode.

This parameter can be accessed if:

- **[Type of stop] 5 5 5** is set to **[DC injection] d 1 ,** or
- **[DC.Brake DI] d 1 ,** is not set to **[No] n 0.**

Setting ()	Description
0.1...1.41 In ⁽¹⁾	Setting range This setting is independent of the [Auto DC Injection] A d C - function. Factory setting: 0.7 In ⁽¹⁾
(1) In corresponds to the rated drive current indicated in the Installation Manual and on the drive nameplate.	

[DC injection time 1] t d , ★

DC injection time 1.

NOTICE
<p>OVERHEATING</p> <p>Verify that the connected motor is properly rated for the DC injection current to be applied in terms of amount and time.</p> <p>Failure to follow these instructions can result in equipment damage.</p>

Maximum current injection time [DC inject. level 1] i d C . After this time, the injection current becomes [DC inject. level 2] i d C 2 .

This parameter can be accessed if:

- [Type of stop] S t t is set to [DC injection] d C i , or
- [DC.Brake DI] d C i is not set to [No] n o .

Setting ()	Description
0.1...30 s	Setting range This setting is independent of the [Auto DC Injection] A d C - function. Factory setting: 0.5 s

[DC inject. level 2] i d C 2 ★

DC injection current 2.

NOTICE
<p>OVERHEATING</p> <p>Verify that the connected motor is properly rated for the DC injection current to be applied in terms of amount and time.</p> <p>Failure to follow these instructions can result in equipment damage.</p>

Injection current activated by digital input or selected as stop mode once period [DC injection time 1] t d i has elapsed.

This parameter can be accessed if:

- [Type of stop] S t t is set to [DC injection] d C i , or
- [DC Injection Assign] d C i is not set to [No] n o .

Setting ()	Description
0.1 In ⁽¹⁾ ...[DC inject. level 1] r d C	Setting range This setting is independent of the [Auto DC Injection] R d C - function. Factory setting: 0.5 In ⁽¹⁾
(1) In corresponds to the rated drive current indicated in the Installation Manual and on the drive nameplate.	

[DC Inj Time 2] t d C ★

2nd DC injection time.

NOTICE
<p>OVERHEATING</p> <p>Verify that the connected motor is properly rated for the DC injection current to be applied in terms of amount and time.</p> <p>Failure to follow these instructions can result in equipment damage.</p>

Maximum injection time [DC inject. level 2] r d C 2 for injection, selected as stop mode only.

This parameter can be accessed if [Type of stop] 5 t t is set to [DC injection] d C r.

Setting ()	Description
0.1...30 s	Setting range This setting is independent of the [Auto DC Injection] R d C - function. Factory setting: 0.5 s

[SwitchOnDisable Stp] d o t d

Disable operation stop mode.

Setting	Code / Value	Description
[Freewheel Stop]	r 5 t	The drive stops in freewheel when switching from the operating state Operation enabled to the operating state Switched on.
[Ramp Stop]	r n P	The drive stops on ramp when switching from the operating state Operation enabled to the operating state Switched on. Factory setting

[Generic functions] - [Auto DC injection]

[Auto DC injection] R d C - Menu

Access

[Complete settings] → [Generic functions] → [Auto DC injection]

About This Menu

This menu presents the automatic injection of motor current function. This is used to hold the rotor of the motor at the end of the deceleration ramp.

[Auto DC Injection] R d C

Automatic DC Injection.

⚠️ DANGER

HAZARD OF ELECTRIC SHOCK, EXPLOSION, OR ARC FLASH

If the parameter [Auto DC Injection] ADC is set to [Continuous] CT, DC injection is always active, even if the motor does not run.

- Verify that using this setting does not result in unsafe conditions.

Failure to follow these instructions will result in death or serious injury.

⚠️ WARNING

UNINTENDED MOVEMENT

- Do not use DC injection to generate holding torque when the motor is at a standstill.
- Use a holding brake to keep the motor in the standstill position.

Failure to follow these instructions can result in death, serious injury, or equipment damage.

Automatic current injection on stopping (at the end of the ramp).

Setting ()	Code / Value	Description
[No]	n o	No injection
[Yes]	y e s	Adjustable injection time Factory setting
[Continuous]	C t	Continuous standstill injection

[Auto DC inj Level 1] S d C I★

Auto DC injection level 1.

NOTICE
<p>OVERHEATING</p> <p>Verify that the connected motor is properly rated for the DC injection current to be applied in terms of amount and time.</p> <p>Failure to follow these instructions can result in equipment damage.</p>

Level of standstill DC injection current.

This parameter can be accessed if [Auto DC Injection] *A d C* is not set to [No] *n o*.

Setting (°)	Description
0...1.1 In ⁽¹⁾	Setting range Factory setting: 0.7 In ⁽¹⁾
(1) In corresponds to the rated drive current indicated in the Installation Manual and on the drive nameplate.	

[Auto DC Inj Time 1] 5 d C 1★

Auto DC injection time 1.

NOTICE
<p>OVERHEATING</p> <p>Verify that the connected motor is properly rated for the DC injection current to be applied in terms of amount and time.</p> <p>Failure to follow these instructions can result in equipment damage.</p>

This parameter can be accessed if [Auto DC Injection] *A d C* is not set to [No] *n o*.

This time corresponds to the zero speed maintenance time, if [Motor control type] *C t t* is set to [SYN_U VC] *S Y n u* or [Reluctance Motor] *S r v C*.

Setting (°)	Description
0.1...30.0 s	Setting range Factory setting: 0.5 s

[Auto DC inj Level 2] 5 d C 2★

Auto DC injection level 2.

NOTICE
<p>OVERHEATING</p> <p>Verify that the connected motor is properly rated for the DC injection current to be applied in terms of amount and time.</p> <p>Failure to follow these instructions can result in equipment damage.</p>

Second level of standstill DC injection current.

This parameter can be accessed if [Auto DC Injection] *A d C* is not set to [No] *n o*.

Setting ()	Description
0...1.1 I _n ⁽¹⁾	Setting range Factory setting: 0.5 I _n ⁽¹⁾
(1) I _n corresponds to the rated drive current indicated in the Installation Manual and on the drive nameplate.	

[Auto DC Inj Time 2] 5 5 2 ★

Auto DC injection time 2.

NOTICE

OVERHEATING

Verify that the connected motor is properly rated for the DC injection current to be applied in terms of amount and time.

Failure to follow these instructions can result in equipment damage.

Second standstill injection time.

This parameter can be accessed if [Auto DC Injection] 5 5 is set to [YES] 5 5.

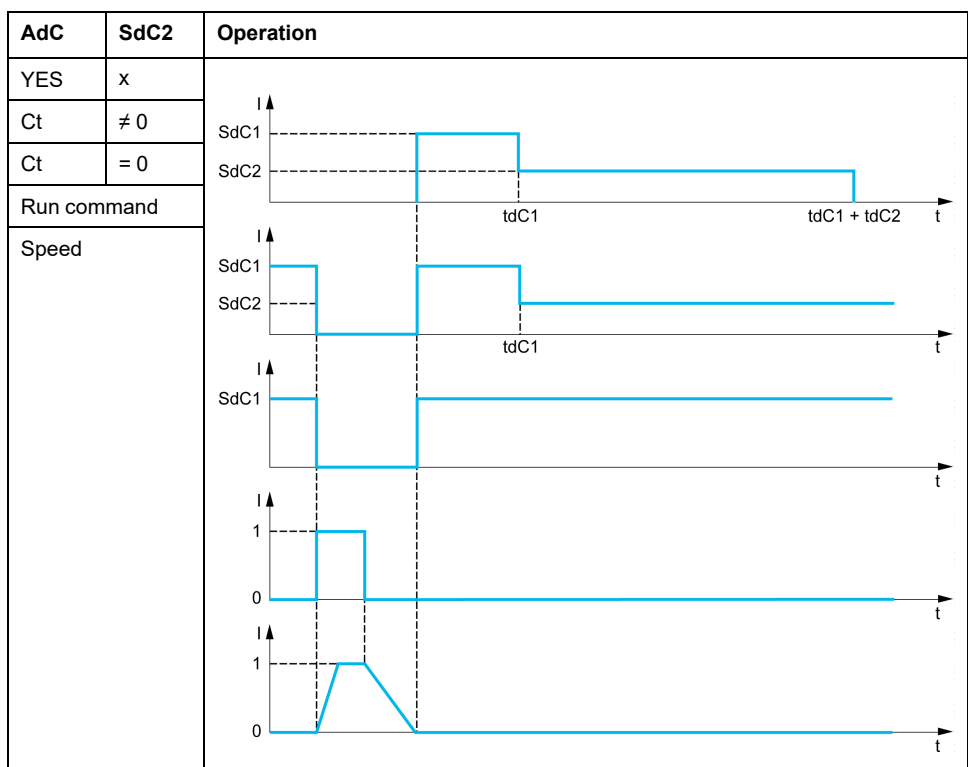

Setting ()	Description
0.0...30.0 s	Setting range Factory setting: 0.0 s

[Generic functions] - [Ref. operations]

[Ref. operations] \square Π 1 - Menu

Access

[Complete settings] \rightarrow [Generic functions] \rightarrow [Ref. operations]

About This Menu

Summing input / subtraction input / multiplier

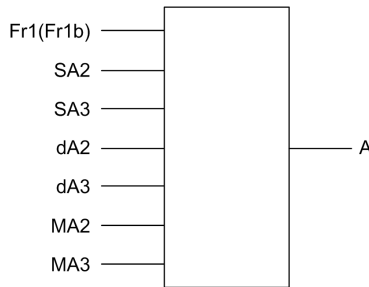

$$A = (Fr1 \text{ or } Fr1b + SA2 + SA3 - dA2 - dA3) \times MA2 \times MA3$$

NOTE:

- If $SA2$, $SA3$, $dA2$, $dA3$ are not assigned, they are set to 0.
- If $MA2$, $MA3$ are not assigned, they are set to 1.
- A is limited by the minimum LSP and maximum HSP parameters.
- For a multiplication, the signal on $MA2$ or $MA3$ is interpreted as a %. 100% corresponds to the maximum value of the corresponding input. If $MA2$ or $MA3$ is sent via the communication bus or Graphic Display Terminal, an FFr multiplication variable must be sent via the bus or Graphic Display Terminal.
- Reversal of the direction of operation in the event of a negative result can be blocked (see [Reverse Disable] \square 10).

[Summing Input 2] $SA2$

Summing input 2.

Selection of a reference to be added to [Ref Freq 1 Config] $Fr1$ or [Ref.1B channel] $Fr1b$.

Setting	Code / Value	Description
[Not Configured]	\square	Not assigned Factory Setting
[AI1]	Π 1	Analog input AI1
[AI2]...[AI3]	Π 2... Π 3	Analog input AI2...AI3
[AI4]...[AI5]	Π 4... Π 5	Analog input AI4...AI5 if VW3A3203 I/O extension module has been inserted
[Ref. Freq- Rmt. Term]	\llcorner \llcorner \llcorner	Reference Frequency via remote terminal
[Ref. Freq- Modbus]	Π d b	Reference frequency via Modbus

Setting	Code / Value	Description
[Ref. Freq-CANopen]	<i>CLAN</i>	Reference frequency via CANopen if a CANopen module has been inserted
[Ref. Freq-Com. Module]	<i>CEC</i>	Reference frequency via fieldbus module if a fieldbus module has been inserted
[Embedded Ethernet]	<i>CEH</i>	Embedded Ethernet
[AI Virtual 1]...[AI Virtual 3]	<i>AV1...AV3</i>	Virtual analogic input 1...3
[DI5 PulseInput Assignment]... [DI6 PulseInput Assignment]	<i>PS...PE</i>	Digital input DI5...DI6 used as pulse input

[Summing Input 3] *S A 3*

Summing input 3.

Selection of a reference to be added to **[Ref Freq 1 Config]** *Fr1* or **[Ref.1B channel]** *Fr1b*.

Identical to **[Summing Input 2]** *S A 2*

[Subtract Ref Freq 2] *SA 2*

Subtract reference frequency 2.

Selection of a reference to be subtracted from **[Ref Freq 1 Config]** *Fr1* or **[Ref.1B channel]** *Fr1b*.

Identical to **[Summing Input 2]** *S A 2*

[Subtract Ref Freq 3] *SA 3*

Subtract reference frequency 3.

Selection of a reference to be subtracted from **[Ref Freq 1 Config]** *Fr1* or **[Ref.1B channel]** *Fr1b*.

Identical to **[Summing Input 2]** *S A 2*.

[Ref Freq 2 Multiply] *MA 2*

Reference frequency 2 multiply (in % of the source range).

Selection of a multiplier reference **[Ref Freq 1 Config]** *Fr1* or **[Ref.1B channel]** *Fr1b*.

Identical to **[Summing Input 2]** *S A 2*.

[Ref Freq 3 Multiply] *MA 3*

Reference frequency 3 multiply (in % of the source range).

Selection of a multiplier reference **[Ref Freq 1 Config]** *Fr1* or **[Ref.1B channel]** *Fr1b*.

Identical to **[Summing Input 2]** *S A 2*.

[Generic functions] - [Preset speeds]

[Preset speeds] $P 5 5$ - Menu

Access

[Complete settings] \rightarrow [Generic functions] \rightarrow [Preset speeds]

About This Menu

NOTE: This function cannot be used with some other functions.

Combination Table for Preset Speed Inputs

2, 4, 8 or 16 speeds can be preset, requiring 1, 2, 3 or 4 digital inputs respectively.

It is necessary to configure:

- 2 and 4 speeds in order to obtain 4 speeds.
- 2, 4 and 8 speeds in order to obtain 8 speeds.
- 2, 4, 8 and 16 speeds in order to obtain 16 speeds.

16 Preset Freq (PS16)	8 Preset Freq (PS8)	4 Preset Freq (PS4)	2 Preset Freq (PS2)	Speed Reference
0	0	0	0	Reference 1 ⁽¹⁾
0	0	0	1	SP2
0	0	1	0	SP3
0	0	1	1	SP4
0	1	0	0	SP5
0	1	0	1	SP6
0	1	1	0	SP7
0	1	1	1	SP8
1	0	0	0	SP9
1	0	0	1	SP10
1	0	1	0	SP11
1	0	1	1	SP12
1	1	0	0	SP13
1	1	0	1	SP14
1	1	1	0	SP15
1	1	1	1	SP16

(1) Reference 1 = $5 P 1$, refer to diagram , page 228

[2 Preset Freq] $P 5 2$

2 preset freq assignment.

Setting	Code / Value	Description
[Not Assigned]	$n o$	Not assigned Factory setting
[DI1]...[DI6]	$L 1 L 2 L 3 L 4 L 5 L 6$	Digital input DI1...DI6

Setting	Code / Value	Description
[DI11]...[DI16]	L 1 1 1... L 1 1 6	Digital input DI11...DI16 if VW3A3203 I/O extension module has been inserted
[CD00]... [CD10]	C d 0 0... C d 1 0	Virtual digital input CMD.0...CMD.10 in [I/O profile] , 0 configuration
[CD11]... [CD15]	C d 1 1... C d 1 5	Virtual digital input CMD.11...CMD.15 regardless of configuration
[C101]... [C110]	C 1 0 1... C 1 1 0	Virtual digital input CMD1.01...CMD1.10 with integrated Modbus Serial in [I/O profile] , 0 configuration
[C111]... [C115]	C 1 1 1... C 1 1 5	Virtual digital input CMD1.11...CMD1.15 with integrated Modbus Serial regardless of configuration
[C201]... [C210]	C 2 0 1... C 2 1 0	Virtual digital input CMD2.01...CMD2.10 with CANopen® fieldbus module in [I/O profile] , 0 configuration
[C211]... [C215]	C 2 1 1... C 2 1 5	Virtual digital input CMD2.11...CMD2.15 with CANopen® fieldbus module regardless of configuration
[C301]... [C310]	C 3 0 1... C 3 1 0	Virtual digital input CMD3.01...CMD3.10 with a fieldbus module in [I/O profile] , 0 configuration
[C311]... [C315]	C 3 1 1... C 3 1 5	Virtual digital input CMD3.11...CMD3.15 with a fieldbus module regardless of configuration
[C501]... [C510]	C 5 0 1... C 5 1 0	Virtual digital input CMD5.01...CMD5.10 with integrated Ethernet in [I/O profile] , 0 configuration
[C511]... [C515]	C 5 1 1... C 5 1 5	Virtual digital input CMD5.11...CMD5.15 with integrated Ethernet regardless of configuration

[4 Preset Freq] P 5 4

4 preset freq assignment.

Identical to **[2 Preset Freq] P 5 2**

To obtain 4 speeds, you must also configure 2 speeds.

[8 Preset Freq] P 5 8

8 preset freq assignment.

Identical to **[2 Preset Freq] P 5 2**

To obtain 8 speeds, you must also configure 2 and 4 speeds.

[16 Preset Freq] P 5 16

16 preset freq assignment.

Identical to **[2 Preset Freq] P 5 2**

To obtain 16 speeds, you must also configure 2, 4 and 8 speeds.

[Preset speed 2] S P 2 to [Preset speed 16] S P 16★

Preset speed 2 to preset speed 16. See the combination table for preset speed inputs, page 450.

Setting 	Description
0.0...500.0 Hz	<p>Setting range</p> <p>Factory setting:</p> <ul style="list-style-type: none">• [Preset speed 2] <i>SP2</i>: 10.0 Hz• [Preset speed 3] <i>SP3</i>: 15.0 Hz• [Preset speed 4] <i>SP4</i>: 20.0 Hz• [Preset speed 5] <i>SP5</i>: 25.0 Hz• [Preset speed 6] <i>SP6</i>: 30.0 Hz• [Preset speed 7] <i>SP7</i>: 35.0 Hz• [Preset speed 8] <i>SP8</i>: 40.0 Hz• [Preset speed 9] <i>SP9</i>: 45.0 Hz• [Preset speed 10] <i>SP10</i>: 50.0 Hz• [Preset speed 11] <i>SP11</i>: 55.0 Hz• [Preset speed 12] <i>SP12</i>: 60.0 Hz• [Preset speed 13] <i>SP13</i>: 70.0 Hz• [Preset speed 14] <i>SP14</i>: 80.0 Hz• [Preset speed 15] <i>SP15</i>: 90.0 Hz• [Preset speed 16] <i>SP16</i>: 100.0 Hz

[Generic functions] - [+/- speed]

[+/- speed] *U P d -* Menu

Access

[Complete settings] → [Generic functions] → [+/- speed]

About This Menu

This function can be accessed if reference channel [Ref Freq 2 Config] *F r 2* is set to [Ref Frequency via DI] *U P d t*

NOTE: This function cannot be used with some other functions.

2 types of operations are available:

- **Use of single action keys:** 2 digital inputs are required in addition to the operating directions.

The input assigned to the “+ speed” command increases the speed, the input assigned to the “- speed” command decreases the speed.

- **Use of double action keys:** Only one digital input assigned to “+ speed” is required.

+/- speed with double-press buttons:

Description: 1 button pressed twice (2 steps) for each direction of rotation. A contact closes each time the button is pressed.

Setting	Released (- Speed)	First Press (Speed Maintained)	Second Press (Faster)
Forward button	-	a	a and b
Reverse button	-	c	c and d

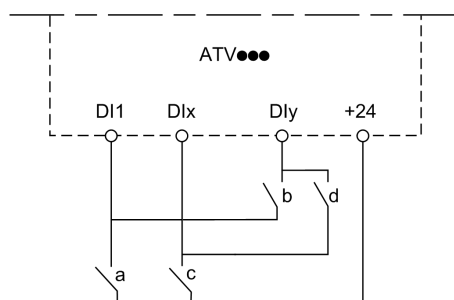

DI1 Forward

DIx Reverse

DIy + speed

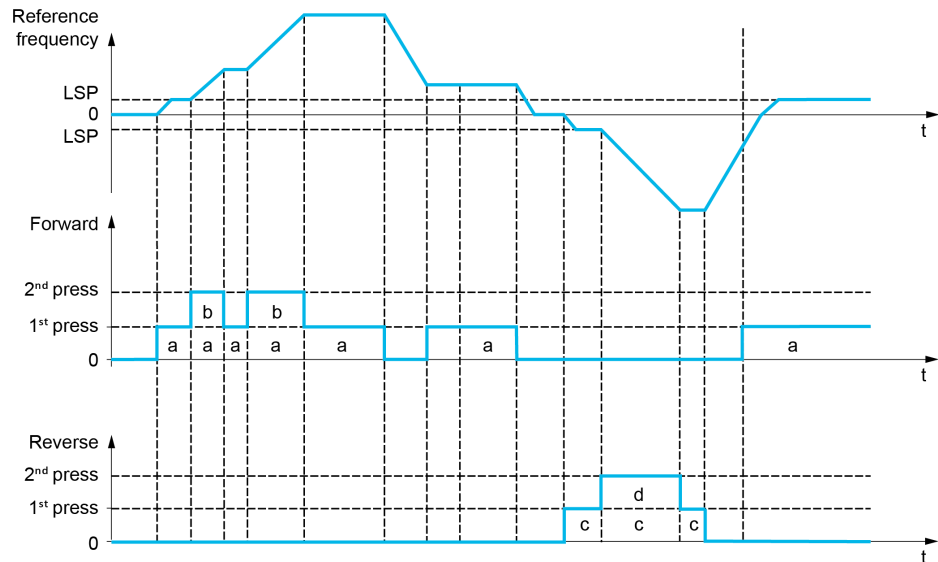

Do not use this +/- speed type with a 3-wire control.

Whichever type of operation is selected, the max. speed is set by **[High speed] H 5 P**.

NOTE: If the reference is switched via **[Freq Switch Assign] r F L** from any reference channel to another reference channel with "+/- speed", the value of reference **[Motor Frequency] r F r** (after ramp) may be copied at the same time in accordance with the **[Copy Ch1-Ch2] L 0 P** parameter.

This helps to prevent the speed from being incorrectly reset to zero when switching takes place.

[+ Speed Assign] 5 P

Increase speed input assignment.

Function active if the assigned input or bit is at 1.

Setting	Code / Value	Description
[Not Assigned]	0 0	Not assigned Factory setting
[DI1]...[DI6]	L 1 L 6	Digital input DI1...DI6
[DI11]...[DI16]	L 11 L 16	Digital input DI11...DI16 if VW3A3203 I/O extension module has been inserted
[CD00]... [CD10]	L 00 L 10	Virtual digital input CMD.0...CMD.10 in [I/O profile] configuration
[CD11]... [CD15]	L 11 L 15	Virtual digital input CMD.11...CMD.15 regardless of configuration
[C101]... [C110]	L 101 L 110	Virtual digital input CMD1.01...CMD1.10 with integrated Modbus Serial in [I/O profile] configuration
[C111]... [C115]	L 111 L 115	Virtual digital input CMD1.11...CMD1.15 with integrated Modbus Serial regardless of configuration
[C201]... [C210]	L 201 L 210	Virtual digital input CMD2.01...CMD2.10 with CANopen® fieldbus module in [I/O profile] configuration
[C211]... [C215]	L 211 L 215	Virtual digital input CMD2.11...CMD2.15 with CANopen® fieldbus module regardless of configuration
[C301]... [C310]	L 301 L 310	Virtual digital input CMD3.01...CMD3.10 with a fieldbus module in [I/O profile] configuration
[C311]... [C315]	L 311 L 315	Virtual digital input CMD3.11...CMD3.15 with a fieldbus module regardless of configuration

Setting	Code / Value	Description
[C501]... [C510]	5 0 1... 5 1 0	Virtual digital input CMD5.01...CMD5.10 with integrated Ethernet in [I/O profile] configuration
[C511]... [C515]	5 1 1... 5 1 5	Virtual digital input CMD5.11...CMD5.15 with integrated Ethernet regardless of configuration

[- Speed Assign] 5 5 P

Down speed input assignment. See the assignment conditions.

Parameter settings identical to **[+ Speed Assign]** 5 5 P.

Function active if the assigned input or bit is at 1.

[Ref Frequency Save] 5 5 r ★

Reference frequency saves. This parameter can be accessed if **[+ Speed Assign]** 5 5 P is not set to **[Not Assigned]** n o or **[- Speed Assign]** 5 5 P is not set to **[Not Assigned]** n o.

Associated with the "+/- speed" function, this parameter can be used to save the reference:

- When the run commands disappear (saved to RAM).
- When the supply mains or the run commands disappear (saved to EEPROM).

Therefore, next time the drive starts up, the speed reference is the last reference frequency saved.

Setting	Code / Value	Description
[No save]	n o	Not saved Factory setting
[Save to RAM]	r R Π	+/- speed with saving of the reference frequency in RAM
[Save to EEPROM]	E E P	+/- speed with saving of the reference frequency in EEPROM

[Generic functions] - [Jump frequency]

[Jump frequency] $J \cup F$ - Menu

Access

[Complete settings] \rightarrow [Generic functions] \rightarrow [Jump frequency]

About This Menu

Identical to [Jump frequency] $J \cup F$ - Menu , page 424.

[Generic functions] - [PID controller]

[PID Controller] $P \cup d$ - Menu

Access

[Complete settings] \rightarrow [Generic functions] \rightarrow [PID Controller]

About This Menu

Identical to [PID Controller] $P \cup d$ - Menu , page 306.

[Generic functions] - [Feedback mon.]

[Feedback monitoring] $F K \Pi$ - Menu

Access

[Complete settings] \rightarrow [Generic functions] \rightarrow [Feedback monitoring]

About This Menu

Identical to [Feedback monitoring] $F K \Pi$ - Menu , page 343.

[Generic functions] - [Threshold reached]

[Threshold reached] E H r E - Menu

Access

[Complete settings] → [Generic functions] → [Threshold reached]

[Low I Threshold] C E d L

Current low threshold value (for [Low Current Reached] C E R L warning).

Setting (C)	Description
0...65,535 A	Setting range Factory setting: 0 A

[High Current Thd] C E d

Current high threshold value (for [Current Thd Reached] C E R warning).

Setting (C)	Description
0...65,535 A	Setting range Factory setting: Drive nominal current

[Low Freq. Threshold] F E d L

Motor low frequency threshold (for [Mot Freq Low Thd] F E R L warning).

Setting (C)	Description
0.0...500.0 Hz	Setting range Factory setting: 0.0 Hz

[Motor Freq Thd] F E d

Motor frequency threshold (for [Mot Freq High Thd] F E R warning).

Setting (C)	Description
0.0...500.0 Hz	Setting range Factory setting: 50.0 Hz

[2 Freq. Threshold] F 2 d L

Motor low frequency second threshold (for [Mot Freq Low Thd 2] F 2 R L warning).

Setting 	Description
0.0...500.0 Hz	Setting range Factory setting: 0.0 Hz

[Freq. threshold 2] F 2 d

Motor frequency threshold 2 (for [Mot Freq High Thd 2] F 2 A warning).

Setting 	Description
0.0...500.0 Hz	Setting range Factory setting: 50.0 Hz

[Motor Thermal Thd] t t d

Motor thermal state threshold (for [Motor Therm Thd reached] t 5 A warning).

Setting 	Description
0...118%	Setting range Factory setting: 100%

[Reference high Thd] r t d

Reference frequency high threshold (for [Ref Freq High Thd reached] r t A H warning).

Setting 	Description
0.0...500.0 Hz	Setting range Factory setting: 0.0 Hz

[Reference low Thd] r t d L

Reference frequency low threshold (for [Ref Freq Low Thd reached] r t A L warning).

Setting 	Description
0.0...500.0 Hz	Setting range Factory setting: 0.0 Hz

[High torque thd.] t t H

High torque threshold (for [High Torque Warning] t t A H warning).

Setting 	Description
-300...300%	Setting range Factory setting: 100%

[Low torque thd.] \llcorner \llcorner \llcorner

Low torque threshold (for [Low Torque Warning] \llcorner \llcorner \llcorner \llcorner warning).

Setting \llcorner	Description
-300...300%	Setting range Factory setting: 50%

[Generic functions] - [Mains contactor command]

[Mains contactor command] \llcorner \llcorner \llcorner - Menu

Access

[Complete settings] \rightarrow [Generic functions] \rightarrow [Mains contactor command]

About This Menu

The line contactor closes every time a run command (forward or reverse) is sent and opens after every stop, as soon as the drive is locked. For example, if the stop mode is stop on ramp, the contactor opens when the motor reaches zero speed.

NOTE: The drive control power supply must be provided via an external 24 Vdc source.

NOTICE

DAMAGE TO THE DRIVE

Do not use this function at intervals of less than 60 s.

Failure to follow these instructions can result in equipment damage.

Example circuit (24 Vdc power supply):

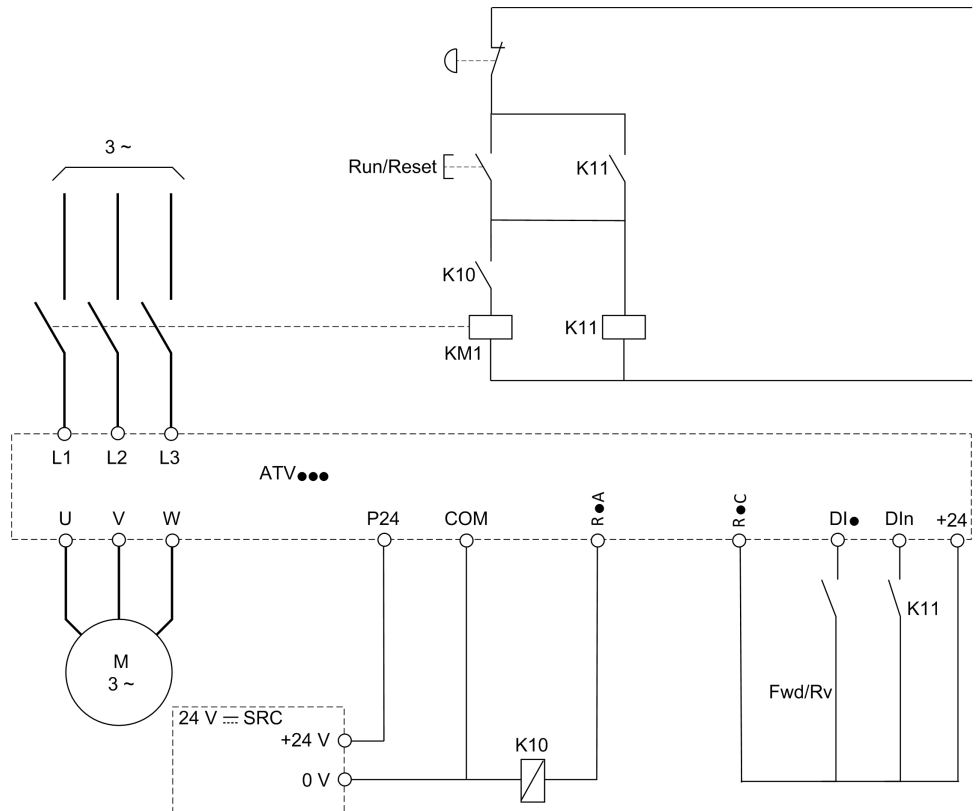

DI• = Run command **[Forward]** F r d or **[Reverse]** r r 5

R•A/R•C = **[Mains Contactor]** L L E

DIIn = **[Drive Lock]** L E 5

NOTE: The Run/Reset key must be pressed once the emergency stop key has been released.

[Mains Contactor] L L E

Mains contactor control.

Setting	Code / Value	Description
[No]	n o	Not assigned Factory setting
[R2]...[R3]	r 2 ... r 3	Relay output R2...R3
[R4]...[R6]	r 4 ... r 6	Relay output R4...R6 if VW3A3204 relay output option module has been inserted
[DQ11 Digital Output]... [DQ12 Digital Output]	d o 1 1... d o 1 2	Digital output DQ11...DQ12 if VW3A3203 I/O extension module has been inserted
[R61]...[R66]	r 6 1 ... r 6 6	Relay R61 ...R66 NOTE: This selection can be accessed on ATV660 and ATV680 equipped with Cabinet IO

[Drive Lock] L E 5★

Drive lock assignment.

This parameter can be accessed if:

- [Mains Contactor] L L C is assigned, or
- [CB start pulse activated] L b E P is assigned, or
- [CB stop pulse activated] L b d P is assigned.

The drive locks when the assigned input or bit changes to 0.

Setting	Code / Value	Description
[Not Assigned]	n o	Not assigned Factory setting
[CD00]... [CD10]	C d 0 0 ... C d 1 0	Virtual digital input CMD.0...CMD.10 in [I/O profile] , o configuration
[CD11]... [CD15]	C d 1 1 ... C d 1 5	Virtual digital input CMD.11...CMD.15 regardless of configuration
[C101]... [C110]	C 1 0 1 ... C 1 1 0	Virtual digital input CMD1.01...CMD1.10 with integrated Modbus Serial in [I/O profile] , o configuration
[C111]... [C115]	C 1 1 1 ... C 1 1 5	Virtual digital input CMD1.11...CMD1.15 with integrated Modbus Serial regardless of configuration
[C201]... [C210]	C 2 0 1 ... C 2 1 0	Virtual digital input CMD2.01...CMD2.10 with CANopen® fieldbus module in [I/O profile] , o configuration
[C211]... [C215]	C 2 1 1 ... C 2 1 5	Virtual digital input CMD2.11...CMD2.15 with CANopen® fieldbus module regardless of configuration
[C301]... [C310]	C 3 0 1 ... C 3 1 0	Virtual digital input CMD3.01...CMD3.10 with a fieldbus module in [I/O profile] , o configuration
[C311]... [C315]	C 3 1 1 ... C 3 1 5	Virtual digital input CMD3.11...CMD3.15 with a fieldbus module regardless of configuration
[C501]... [C510]	C 5 0 1 ... C 5 1 0	Virtual digital input CMD5.01...CMD5.10 with integrated Ethernet Modbus TCP in [I/O profile] , o configuration
[C511]... [C515]	C 5 1 1 ... C 5 1 5	Virtual digital input CMD5.11...CMD5.15 with integrated Ethernet Modbus TCP regardless of configuration
[DI1 (Low level)]...[DI6 (Low level)]	L 1 L ... L 6 L	Digital input DI1...DI6 used at low level
[DI11 (Low level)]...[DI16 (Low level)]	L 1 1 L ... L 1 6 L	Digital input DI11...DI16 used at low level if VW3A3203 I/O extension module has been inserted
[DI52 (Low level)]...[DI59 (Low level)]	d 5 2 L ... d 5 9 L	Digital input DI52...DI59 (low level) NOTE: This selection can be accessed on ATV660 and ATV680 equipped with Cabinet IO.
[DI52 (High level)]... [DI59 (High level)]	d 5 2 H ... d 5 9 H	Cabinet high level digital inputs NOTE: This selection can be accessed on ATV660 and ATV680 equipped with Cabinet IO.

[Mains V. time out] L C L

Monitoring time for closing of line contactor.

Setting	Description
1...999 s	Setting range Factory setting: 5 s

[Generic functions] - [Output contactor cmd]

[Output contactor cmd] 5 5 - Menu

Access

[Complete settings] → [Generic functions] → [Output contactor cmd]

About This Menu

This function allows the drive to control and/or monitor a contactor installed between the drive and the motor.

The control of the output contactor by the drive is activated by assigning **[Out. contactor Assign] 5 5**. A request to close the contactor is done when a run command is activated. A request to open the contactor is done when no current is applied to the motor.

The monitoring of the output contactor by the drive is activated by assigning the feedback to **[Output contact. Fdbk] 5 5**. In the event of an inconsistency, the drive triggers:

- **[Out Contact Opened Error] 5 5 2** error, if the **[Output contact. Fdbk] 5 5** is not closed before the end of **[Delay to motor run] 5 5** or if the **[Output contact. Fdbk] 5 5** opens if the motor is running.
- **[Out Contact Closed Error] 5 5 1** error, if **[Output contact. Fdbk] 5 5** is not opened before the end of **[Delay to open con.] 5 5** or if the **[Output contact. Fdbk] 5 5** closes if the motor is stopped.

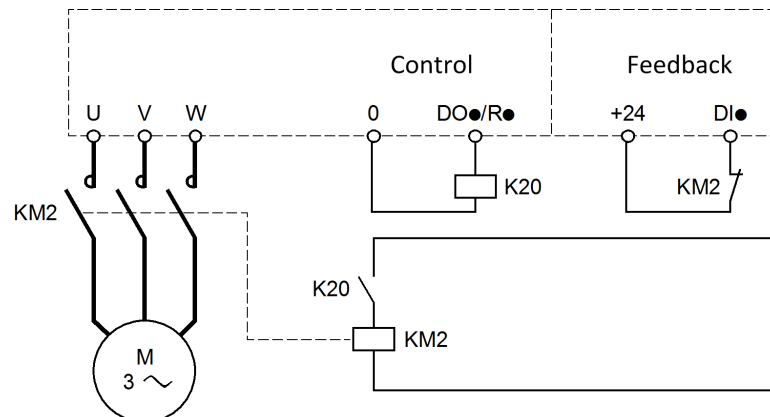

NOTE:

- **[Out Contact Opened Error] 5 5 2** error can be cleared by a transition from 1 to 0 of the run command.
- **[Out. contactor Assign] 5 5** and **[Output contact. fdbk] 5 5** can be used individually.
- If the DC injection braking function is used, the output contactor does not close as long as DC injection braking is active

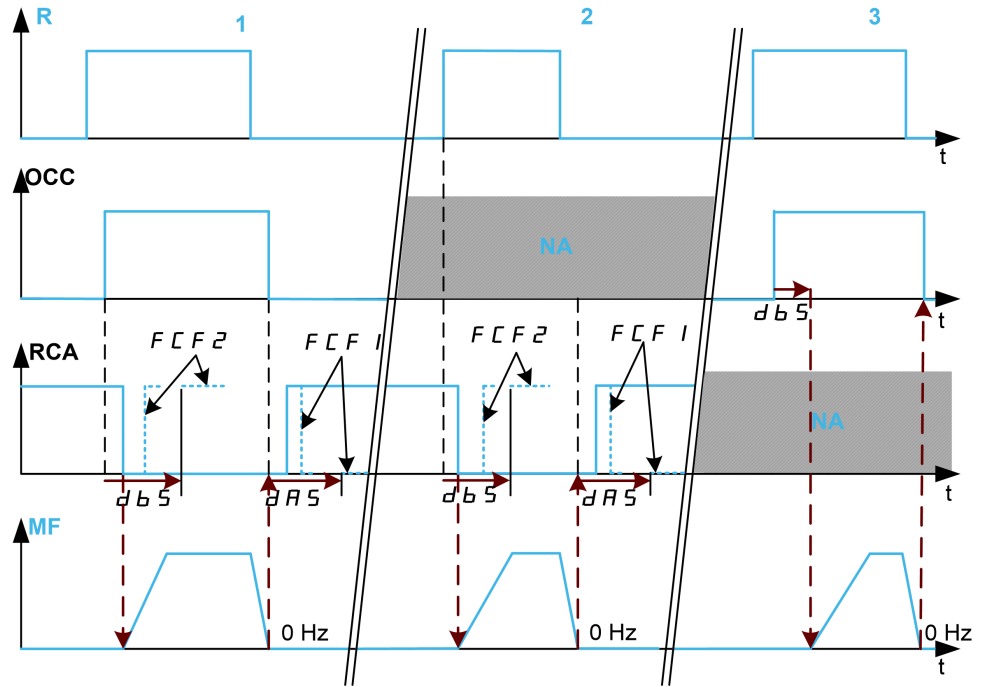

1 OCC and RCA assigned

2 RCA assigned

3 OCC assigned

t Time

R Run command

OCC Output contactor

RCA Output contactor feedback

NA Not Assigned

MF Motor frequency

[Out. Contactor Assign] 5.5.5

Output contactor control.

Setting	Code / Value	Description
[No]	no	Function not assigned. Factory setting
[R2]...[R3]	r 2...r 3	Relay output R2...R3
[R4]...[R6]	r 4...r 6	Relay output R4...R6 if VW3A3204 relay output option module has been inserted.
[DQ11 Digital Output]... [DQ12 Digital Output]	do 11... do 12	Digital output DQ11...DQ12 if VW3A3203 I/O extension module has been inserted.
[R61]...[R66]	r 6 1...r 6 6	Relay R61 ...R66 NOTE: This selection can be accessed on ATV660 and ATV680 equipped with Cabinet IO

[Output contact fdbk] 5.5.6

Output contactor fdbk.

The motor starts to run when the assigned digital input or bit switches to 0.

Setting	Code / Value	Description
[Not Assigned]	n o	Not assigned Factory setting
[DI1 (Low level)]...[DI6 (Low level)]	L 1 L ... L 6 L	Digital input DI1...DI6 used at low level
[DI11 (Low level)]...[DI16 (Low level)]	L 1 1 L ... L 1 6 L	Digital input DI11...DI16 used at low level if VW3A3203 I/O extension module has been inserted
[C101]... [C110]	C 1 0 1 ... C 1 1 0	Virtual digital input CMD1.01...CMD1.10 with integrated Modbus Serial in [I/O profile] , o configuration
[C111]... [C115]	C 1 1 1 ... C 1 1 5	Virtual digital input CMD1.11...CMD1.15 with integrated Modbus Serial regardless of configuration
[C201]... [C210]	C 2 0 1 ... C 2 1 0	Virtual digital input CMD2.01...CMD2.10 with CANopen® fieldbus module in [I/O profile] , o configuration
[C211]... [C215]	C 2 1 1 ... C 2 1 5	Virtual digital input CMD2.11...CMD2.15 with CANopen® fieldbus module regardless of configuration
[C301]... [C310]	C 3 0 1 ... C 3 1 0	Virtual digital input CMD3.01...CMD3.10 with a fieldbus module in [I/O profile] , o configuration
[C311]... [C315]	C 3 1 1 ... C 3 1 5	Virtual digital input CMD3.11...CMD3.15 with a fieldbus module regardless of configuration
[C501]... [C510]	C 5 0 1 ... C 5 1 0	Virtual digital input CMD5.01...CMD5.10 with integrated Ethernet Modbus TCP in [I/O profile] , o configuration
[C511]... [C515]	C 5 1 1 ... C 5 1 5	Virtual digital input CMD5.11...CMD5.15 with integrated Ethernet Modbus TCP regardless of configuration

[Delay to motor run] d b 5

Delay to close o/p cont.

This parameter delays:

- Motor control following the sending of a run command when the drive only monitors the output contactor.
- The **[Out Contact Opened Error]** F C F 2 error monitoring if the **[Output contact fdbk]** r C R is assigned.

The time delay must be greater than the closing time of the output contactor.

This parameter can be accessed if **[Out. contactor Assign]** o C C or **[Output contact fdbk]** r C R is assigned.

Setting	Description
0.05...60.00 s	Setting range Factory setting: 0.15 s

[Delay to open con.] d R 5

Delay to open contactor

This delay must be greater than the opening time of the output contactor.

If the value of digital input assigned to the **[Output contact fdbk]** r C R is not 0 at the end of this delay, **[Out Contact Closed Error]** F C F 1 error is triggered. If this parameter is set to 0, the **[Out Contact Closed Error]** F C F 1 error is not monitored.

This parameter can be accessed if **[Output contact fdbk]** r C R is assigned.

Setting	Description
0.00...5.00 s	Setting range Factory setting: 0.10 s

[Generic functions] - [Reverse disable]

[Reverse disable] r E 1 n - Menu

Access

[Complete settings] → [Generic functions] → [Reverse disable]

[Reverse Disable] r 1 n

Reverse direction disable.

NOTE: Anti-Jam function takes priority over **[Reverse Disable] r 1 n** function. If an Anti-Jam function is used, reverse direction is applied despite of the **[Reverse disable] r 1 n** configuration.

Reverse direction requests sent by digital inputs are taken into account.

Reverse direction requests sent by the Graphic Display Terminal or sent by the line are not taken into account.

Any reverse speed reference originating from the PID, summing input, and so on, is interpreted as a zero reference (0 Hz).

Setting	Code / Value	Description
[No]	n 0	Motor rotation direction is defined by the run command [Forward] F r d or [Reverse] r r 5 and the sign of the reference frequency. When the reference frequency is positive and a: <ul style="list-style-type: none"> • [Forward] F r d run command is given: the motor starts in forward direction • [Reverse] r r 5 run command is given: the motor starts in reverse direction When the reference frequency is negative and a: <ul style="list-style-type: none"> • [Forward] F r d run command is given: the motor starts in reverse direction • [Reverse] r r 5 run command is given: the motor starts in forward direction
[Yes]	Y E 5	Any reverse speed reference originating from the PID, summing input, and so on, is interpreted as a zero reference (0 Hz).
[Absolute]	A b 5	Motor rotation direction is defined by the run command [Forward] F r d or [Reverse] r r 5 regardless of the sign of the reference frequency (i.e only the absolute value of the reference frequency is considered).

[Generic functions] - [Torque limitation]

[Torque limitation] E L - Menu

Access

[Complete settings] → [Generic functions] → [Torque limitation]

About This Menu

The value of the torque limitation is fixed by a parameter.

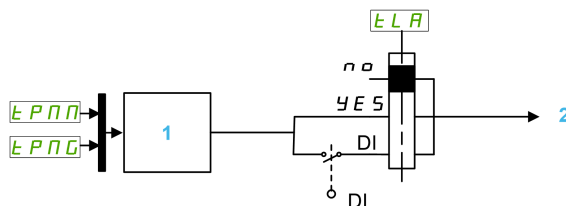

1 Torque limitation via parameter in power

2 Limitation Value

[Torque limit activ.] E L R

Activation of the permanent torque limitation.

If the assigned input or bit is at 0, the function is inactive.

If the assigned input or bit is at 1, the function is active.

Setting	Code / Value	Description
[Not Assigned]	n a	Not assigned Factory setting
[Yes]	y e s	Yes
[DI1]...[DI6]	L , 1...L , 6	Digital input DI1...DI6
[DI11]...[DI16]	L , 11... L , 16	Digital input DI11...DI16 if VW3A3203 I/O extension module has been inserted
[CD00]... [CD10]	C d 0 0... C d 1 0	Virtual digital input CMD.0...CMD.10 in [I/O profile] , a configuration
[CD11]... [CD15]	C d 1 1... C d 1 5	Virtual digital input CMD.11...CMD.15 regardless of configuration
[C101]... [C110]	C 1 0 1... C 1 1 0	Virtual digital input CMD1.01...CMD1.10 with integrated Modbus Serial in [I/O profile] , a configuration
[C111]... [C115]	C 1 1 1... C 1 1 5	Virtual digital input CMD1.11...CMD1.15 with integrated Modbus Serial regardless of configuration
[C201]... [C210]	C 2 0 1... C 2 1 0	Virtual digital input CMD2.01...CMD2.10 with CANopen® fieldbus module in [I/O profile] , a configuration
[C211]... [C215]	C 2 1 1... C 2 1 5	Virtual digital input CMD2.11...CMD2.15 with CANopen® fieldbus module regardless of configuration
[C301]... [C310]	C 3 0 1... C 3 1 0	Virtual digital input CMD3.01...CMD3.10 with a fieldbus module in [I/O profile] , a configuration
[C311]... [C315]	C 3 1 1... C 3 1 5	Virtual digital input CMD3.11...CMD3.15 with a fieldbus module regardless of configuration

Setting	Code / Value	Description
[C501]... [C510]	C 5 0 1... C 5 1 0	Virtual digital input CMD5.01...CMD5.10 with integrated Ethernet Modbus TCP in [I/O profile] configuration
[C511]... [C515]	C 5 1 1... C 5 1 5	Virtual digital input CMD5.11...CMD5.15 with integrated Ethernet Modbus TCP regardless of configuration

[Pmax Motor] E P Π Π★

Maximum power in motor mode.

This parameter can be accessed if [Torque limit activ.] E L R is not set to [Not Assigned] n a.

Setting ()	Description
10...300%	Setting range Factory setting: 300%

[Pmax Generator] E P Π G★

Maximum acceptable power in generator mode.

This parameter can be accessed if [Torque limit activ.] E L R is not set to [Not Assigned] n a.

Setting ()	Description
10...300%	Setting range Factory setting: 300%

[Generic functions] - [Parameters switching]

[Parameters switching] *PLP* - Menu

Access

[Complete settings] → [Generic functions] → [Parameters switching]

About This Menu

A set of 1 to 15 parameters from the [Parameter Selection] *SP5* list, page 470 can be selected and 2 or 3 different values assigned. These 2 or 3 sets of values can then be switched using 1 or 2 digital inputs or control word bits. This switching can be performed during operation (motor running). It can also be controlled based on 1 or 2 frequency thresholds, whereby each threshold acts as a digital input (0 = threshold not reached, 1 = threshold reached).

	Values 1	Values 2	Values 3
Parameter 1	Parameter 1	Parameter 1	Parameter 1
...
Parameter 15	Parameter 15	Parameter 15	Parameter 15
Input DI or bit or frequency threshold 2 values	0	1	0 or 1
Input DI or bit or frequency threshold 3 values	0	0	1

NOTE: Do not modify the parameters in [Parameter Selection] *SP5*, page 470, because any modifications made in this menu will be lost on the next power-up. The parameters can be adjusted during operation in the [Parameters switching] *PLP* - menu, on the active configuration.

[2 Parameter sets] *CHRI*

Parameter switching assignment 1.

Switching 2 parameter sets.

Setting	Code / Value	Description
[Not Assigned]	<i>no</i>	Not assigned Factory setting
[Mot Freq High Thd]	<i>FtR</i>	Motor frequency high threshold reached
[2nd Freq Thd Reached]	<i>F2R</i>	Second frequency threshold reached
[DI1]...[DI6]	<i>L1...L6</i>	Digital input DI1...DI6
[DI11]...[DI16]	<i>L11...L16</i>	Digital input DI11...DI16 if VW3A3203 I/O extension module has been inserted
[CD00]... [CD10]	<i>Cd0...Cd10</i>	Virtual digital input CMD.0...CMD.10 in [I/O profile] <i>no</i> configuration
[CD11]... [CD15]	<i>Cd11...Cd15</i>	Virtual digital input CMD.11...CMD.15 regardless of configuration
[C101]... [C110]	<i>C101...C110</i>	Virtual digital input CMD1.01...CMD1.10 with integrated Modbus Serial in [I/O profile] <i>no</i> configuration

Setting	Code / Value	Description
[C111]... [C115]	C 1 1 1... C 1 1 5	Virtual digital input CMD1.11...CMD1.15 with integrated Modbus Serial regardless of configuration
[C201]... [C210]	C 2 0 1... C 2 1 0	Virtual digital input CMD2.01...CMD2.10 with CANopen® fieldbus module in [I/O profile] , 0 configuration
[C211]... [C215]	C 2 1 1... C 2 1 5	Virtual digital input CMD2.11...CMD2.15 with CANopen® fieldbus module regardless of configuration
[C301]... [C310]	C 3 0 1... C 3 1 0	Virtual digital input CMD3.01...CMD3.10 with a fieldbus module in [I/O profile] , 0 configuration
[C311]... [C315]	C 3 1 1... C 3 1 5	Virtual digital input CMD3.11...CMD3.15 with a fieldbus module regardless of configuration
[C501]... [C510]	C 5 0 1... C 5 1 0	Virtual digital input CMD5.01...CMD5.10 with integrated Ethernet in [I/O profile] , 0 configuration
[C511]... [C515]	C 5 1 1... C 5 1 5	Virtual digital input CMD5.11...CMD5.15 with integrated Ethernet regardless of configuration

[3 Parameter sets] C H R 2

Parameter switching assignment 2.

Identical to [2 Parameter sets] C H R 1.

Switching 3 parameter sets.

NOTE: In order to obtain 3 parameter sets, it is necessary to configure first [2 Parameter sets] C H R 1.

[Parameter Selection] S P 5

This parameter can be accessed if [2 Parameter sets] C H R 1 is not set to [No] n o .

Making an entry in this parameter opens a window containing all the adjustment parameters that can be accessed. Select 1 to 15 parameters using **OK** key. Parameter(s) can also be deselected using **OK** key.

Available parameters for parameters switching function are:

Parameter	Code
[Ramp increment]	i n r
[Acceleration]	R C C
[Deceleration]	d E C
[Acceleration 2]	R C 2
[Deceleration 2]	d E 2
[Begin Acc round]	t R 1
[End Acc round]	t R 2
[Begin Dec round]	t R 3
[End Dec round]	t R 4
[Low Speed]	L S P
[High Speed]	H S P
[Motor Th Current]	i t H
[IR compensation]	u F r
[Slip compensation]	S L P
[K speed loop filter]	S F C

Parameter	Code
[Speed time integral]	S I E
[Speed prop. gain]	S P G
[Inertia Factor]	S P G u
[Ramp Divider]	d C F
[DC Inj Level 1]	i d C
[DC Inj Time 1]	t d i
[DC Inj Level 2]	i d C 2
[DC Inj Time 2]	t d C
[Auto DC inj Level 1]	S d C 1
[Auto DC Inj Time 1]	t d C 1
[Auto DC inj Level 2]	S d C 2
[Auto DC Inj Time 2]	t d C 2
[Switching frequency]	S F r
[Current Limitation]	C L i
[Low Speed Timeout]	t L S
[Sleep Offset Thres.]	S L E
[Preset speed 2]...[Preset speed 16]	S P 2... S P 16
[Multiplying coeff.]	Π F r
[PID Prop.Gain]	r P G
[PID Intgl.Gain]	r i G
[PID derivative gain]	r d G
[PID ramp]	P r P
[PID Min Output]	P o L
[PID Max Output]	P o H
[PID Start Ref Freq]	S F S
[PID acceleration time]	A C C P
[Min fbk Warning]	P R L
[Max fbk Warning]	P R H
[PID error Warning]	P E r
[Speed input %]	P S r
[Ref PID Preset 2]	r P 2
[Ref PID Preset 3]	r P 3
[Ref PID Preset 4]	r P 4
[PID Fdbk Range]	P F Π r
[PID Fdbk Error Delay]	P F Π d
[High Current Thd]	C t d
[Low I Threshold]	C t d L
[High torque thd.]	t t H
[Low torque thd.]	t t L
[Motor Freq Thd]	F t d
[Low Freq.Threshold]	F t d L
[Freq. threshold 2]	F 2 d

Parameter	Code
[2 Freq. Threshold]	F 2 d L
[Freewheel stop Thd]	F F t
[Motor Therm Thd]	t t d
[Reference high Thd]	r t d
[Reference low Thd]	r t d L
[Skip Frequency]	J P F
[Skip Frequency 2]	J F 2
[3rd Skip Frequency]	J F 3
[Skip Freq.Hysteresis]	J F H
[Unld.Thr.Nom.Speed]	L u n
[Unld.Thr.0.Speed]	L u L
[Unld. FreqThr. Det.]	r n u d
[Hysteresis Freq]	S r b
[Underload T.B.Rest.]	F t u
[Ovld Detection Thr.]	L o C
[Overload T.B.Rest.]	F t o
[Fan mode]	F F n
[Pmax Motor]	t P n n
[Pmax Generator]	t P n G
[Stall Max Time]	S t P 1
[Stall Current]	S t P 2
[Stall Frequency]	S t P 3
[AI2 Th Warn Level]	t H 2 A
[AI5 Th Warn Level]	t H 5 A
[AI2 Th Error Level]	t H 2 F
[AI5 Th Error Level]	t H 5 F
[Start Accel Ramp]	R C C S
[Dec. Check Valve]	d E C u
[Check Valve Speed 2]	C u H S
[Check Valve Speed 1]	C u L S
[Final Dec. Ramp]	d E C S
[Sleep Flow Level]	S L n L
[Sleep Min Speed]	S L S L
[Sleep Power Level]	S L P r
[Sleep Pressure Level]	S L P L
[Sleep Delay]	S L P d
[Sleep Boost Speed]	S L b S
[Sleep Boost Time]	S L b t
[Wake Up Process level]	W u P F
[Wake Up Process Error]	W u P E
[Wake Up Press level]	W u P L
[Sleep Condition]	R S L C

Parameter	Code
[Sleep Check Delay]	<i>R S L d</i>
[Check Sleep Ref spd]	<i>R S L r</i>
[Flow Lim Thd Active]	<i>C H t</i>
[FlowLim Thd Disable]	<i>r C H t</i>
[Flow. Limit Dec.]	<i>d F L</i>
[Pipe Fill TiMe]	<i>P F H t</i>
[Pipe Fill SPeEd]	<i>P F H S</i>
[Pipe Fill Pressure]	<i>P F H P</i>
[Priming Time]	<i>P P S d</i>
[Primed Inlet Level]	<i>P P , L</i>
[Primed Condition Delay]	<i>P P F d</i>
[Minimum Pressure]	<i>J P r P</i>
[Delay to start]	<i>J P r d</i>
[Maximum Pressure]	<i>J P S P</i>
[Reference Speed]	<i>J P r S</i>
[Wake up Delay]	<i>J P W d</i>
[Alpha]	<i>F L d R</i>
[Comp. at Point 1]	<i>F L H I</i>
[Flow at Point 1]	<i>F L 9 I</i>
[Static Compensation]	<i>F L H D</i>
[OutPres Min Level]	<i>o P P L</i>
[OutPres Max Level]	<i>o P P H</i>
[OutPresError Delay]	<i>o P P d</i>
[HighFlow MaxLevel]	<i>H F P L</i>
[HighFlowError Delay]	<i>H F P d</i>
[PumpCycle MaxStarts]	<i>P C P n</i>
[PumpCycle Timeframe]	<i>P C P t</i>
[InletPres High Thd]	<i>, P P H</i>
[InletPres Low Thd]	<i>, P P L</i>
[InletPres Max Comp]	<i>, P P C</i>
[Anti-Jam Trigger Time]	<i>J t C t</i>
[Anti-Jam Torque]	<i>J t C L</i>
[Anti-Jam Start Delay]	<i>J t C d</i>
[Anti-Jam Fwd Dec]	<i>J d E C</i>
[Anti-Jam Rv Dec]	<i>J d E r</i>
[Anti-Jam Fwd Acc]	<i>J R C C</i>
[Anti-Jam Rv Acc]	<i>J R C r</i>
[Anti-Jam Fwd Time]	<i>J F d t</i>
[Anti-Jam Rv Time]	<i>J r u t</i>
[Anti-Jam Fwd Speed]	<i>J F d S</i>
[Anti-Jam Rv Speed]	<i>J r u S</i>
[Anti-Jam Stop Time]	<i>J Z S t</i>

Parameter	Code
[Anti-Jam Cycle Nb]	<i>J n b C</i>
[Anti-Jam Max Seq]	<i>J A n n</i>
[Anti-Jam Interval]	<i>J A n t</i>
[DryRun Error Delay]	<i>d r Y d</i>
[DryRun Restart Delay]	<i>d r Y r</i>
[Dry Run Factor]	<i>d r Y X</i>
[PumpLF Min Level]	<i>P L F L</i>
[PumpLF Power Factor]	<i>P L F X</i>
[PumpLF ActivDelay]	<i>P L F A</i>
[PumpLF Error Delay]	<i>P L F d</i>
[PumpLF Restart Delay]	<i>P L F r</i>
[LevelCtrl Random Factor]	<i>L C r X</i>
[Level 1st Pump Start]	<i>L r L 1</i>
[Level 2nd Pump Start]	<i>L r L 2</i>
[Level 3rd Pump Start]	<i>L r L 3</i>
[Level 4th Pump Start]	<i>L r L 4</i>
[Level 5th Pump Start]	<i>L r L 5</i>
[Level 6th Pump Start]	<i>L r L 6</i>
[Level 1st Pump Stop]	<i>L P L 1</i>
[Level 2nd Pump Stop]	<i>L P L 2</i>
[Level 3rd Pump Stop]	<i>L P L 3</i>
[Level 4th Pump Stop]	<i>L P L 4</i>
[Level 5th Pump Stop]	<i>L P L 5</i>
[Level 6th Pump Stop]	<i>L P L 6</i>
[Level 1st Pump at HSP]	<i>L H L 1</i>
[Level 2nd Pump at HSP]	<i>L H L 2</i>
[Level 3rd Pump at HSP]	<i>L H L 3</i>
[Level 4th Pump at HSP]	<i>L H L 4</i>
[Level 5th Pump at HSP]	<i>L H L 5</i>
[Level 6th Pump at HSP]	<i>L H L 6</i>
[LevelCtrl Low Speed]	<i>L C L 5</i>
[Min Delivery Height]	<i>L C d J</i>
[Max Delivery Height]	<i>L C d K</i>
[LevelCtrl S/D Interval]	<i>L C d t</i>
[Booster Stg Speed]	<i>b S S</i>
[Booster Dstg Speed]	<i>b d S</i>
[Booster Stg Delay]	<i>b S d</i>
[Booster Stg Bypass Speed]	<i>b S b S</i>
[Booster Stg Ramp Delay]	<i>b S r d</i>
[Booster Stg Bypass Time]	<i>b S b t</i>
[Booster Dstg Delay]	<i>b d d</i>
[Booster Dstg Bypass Spd]	<i>b d b S</i>

Parameter	Code
[Booster Dstg Ramp Delay]	<i>b d r d</i>
[Booster Dstg Bypass Time]	<i>b d b t</i>
[Booster S/D Interval]	<i>b s d t</i>
[Booster Working Range]	<i>b C W R</i>
[Booster Override Range]	<i>b C o R</i>
[Booster S/D Flow Hyst]	<i>b s d H</i>
[Booster Dstg Flow]	<i>b d F</i>
[FeedFwd Stage Delay]	<i>F F S d</i>
[FeedFwd Destage Delay]	<i>F F d d</i>
[FeedFwd Disturb Gain]	<i>F F G</i>
[FeedFwd Disturb Time]	<i>F F t G</i>
[AFE Generator Mode]	<i>C L , G</i>
[Pump Fixed Freq]	<i>Π P F S</i>
[Pump Op Point Filter]	<i>W P X F</i>

[Set 1] P 5 1 - to [Set 3] P 5 3 -

3 possible sets of values.

Making an entry in this menu opens a settings window containing the selected parameters in the order in which they were selected.

Access to each menu in order to configure their own set of values.

[Generic functions] - [Stop after speed timeout]

[Stop after speed timeout] P r 5 P - Menu

Access

[Complete settings] → [Generic functions] → [Stop after speed timeout]

Sleep/Wake-Up in Speed Control Mode

The drive is in Speed control mode, when PID is not active, typically when:

- PID is not configured (the motor speed setpoint is controlled by an external PLC, for example).
- PID is in manual mode (manual application mode, for example).
- PID is not active because Channel 1 is not selected (forced local mode enabled, for example).

When the drive is used in Speed Control (PID not used or not active), a speed condition is used to switch the application to the sleep state. When the drive is in sleep state, the motor is restarted if the sleep condition disappears.

This function avoids prolonged operation at low speeds when neither useful nor compliant with the system constraints. It stops the motor after a period of operation at reduced speed. This time and speed can be adjusted.

In Speed control mode, Sleep/Wake-up is managed according to the following rules:

- The motor is stopped when [Pre-Ramp Ref Freq] F_{rH} and [Output frequency] r_{FL} become and stay lower than [Low speed] $LSP + [Sleep Offset Thres.]$ SLE during [Low Speed Timeout] ELT .
- The motor is restarted when [Pre-Ramp Ref Freq] $F_{rH} > [Low speed] LSP + [Sleep Offset Thres.] SLE$.

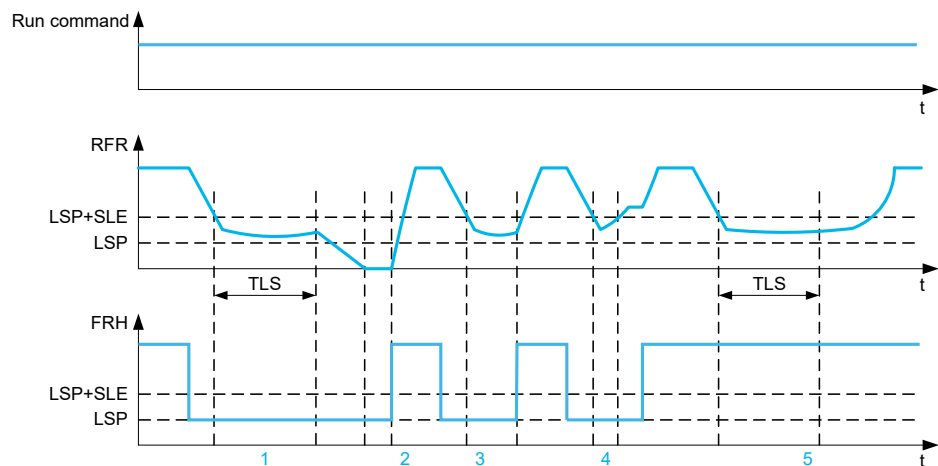

1 Nominal [Low Speed Timeout] L 5 function action: after [Low Speed Timeout] L 5 time, the motor is stopped according to the current deceleration ramp

2 [Pre-Ramp Ref Freq] F r H becomes greater than [Low speed] L 5 P + [Sleep Offset Thres.] S L E and run order still present [Low Speed Timeout] L 5 function is deactivated

3 [Low Speed Timeout] L 5 function is not activated because [Pre-Ramp Ref Freq] F r H becomes greater than [Low speed] L 5 P + [Sleep Offset Thres.] S L E before [Low Speed Timeout] L 5 has expired

4 [Low Speed Timeout] L 5 function is not activated because [Output frequency] r F r becomes greater than [Low speed] L 5 P + [Sleep Offset Thres.] S L E before [Low Speed Timeout] L 5 has expired

5 [Low Speed Timeout] L 5 function is not activated because [Pre-Ramp Ref Freq] F r H stays greater than [Low speed] L 5 P + [Sleep Offset Thres.] S L E

[Low Speed Timeout] L 5

Low speed timeout

Setting ()	Description
0.0...999.9 s	Setting range Factory setting: 0.0 s

[Sleep Offset Thres.] S L E ★

Sleep offset threshold.

This parameter can be accessed if [Low Speed Timeout] L 5 is not set to 0.

Adjustable restart threshold (offset) following a stop after prolonged operation at [Low speed] L 5 P + [Sleep Offset Thres.] S L E, in Hz. The motor restarts if the reference rises above (LSP + SLE) and if a run command is still present.

Setting ()	Description
1.0...[Max Frequency] L F r	Setting range Factory setting: 1.0 Hz

[Generic functions] - [Active Front End]

[Active Front End] HFE - Menu

Access

[Complete settings] \rightarrow [Generic functions] \rightarrow [Active Front End]

About This Menu

This menu is used to set the current limitation for active front end used in generator mode.

If the active front end is running in motor mode, a warning **[AFE Motor Limitation]** \llcorner L , Π is triggered if the current limitation of 120% is reached, a warning **[AFE Regen Limitation]** \llcorner L , \llcorner is triggered when the limitation set with parameter **[AFE Generator Mode]** \llcorner L , \llcorner is reached.

NOTE: This menu can be accessed on ATV680 and ATV6B0.

[AFE Generator Mode] \llcorner L , \llcorner ★

AFE Generator Mode

This parameter sets the current limitation in generator operation mode. If the parameter is set to **[Low Harmonic]** $LH\Pi$ the drive will operate in Low Harmonic but not regenerate energy to the mains.

Setting	Code / Value	Description
[Low Harmonic]	$LH\Pi$	Low Harmonic mode (current to the mains less than 10%). Factory setting
[Low Harmonic & Regen]	$LHr\Pi$	Low Harmonic and Regeneration mode (120%).
0.0...120.0 %		Current limitation in generator mode (for specific setting).

[Generic monitoring]

[Process underload] u L d - Menu

Access

[Complete settings] → [Generic monitoring] → [Process underload]

Process Underload Detected Error

A process underload is detected when the next event occurs and remains pending for a minimum time [Unld T. Del. Detect] u L t, which is configurable:

- The motor is in steady state and the torque is below the set underload limit ([Unld.Thr.0.Speed] L u L, [Unld.Thr.Nom.Speed] L u n, [Unld. FreqThr. Det.] r n u d parameters).
- The motor is in steady state when the offset between the frequency reference and motor frequency falls below the configurable threshold [Hysteresis Freq] S r b.

Between zero frequency and the rated frequency, the curve reflects the following equation: $\text{torque} = L u L + (L u n - L u L) \times (\text{frequency})^2 / (\text{rated frequency})^2$ The underload function is not active for frequencies below r n u d.

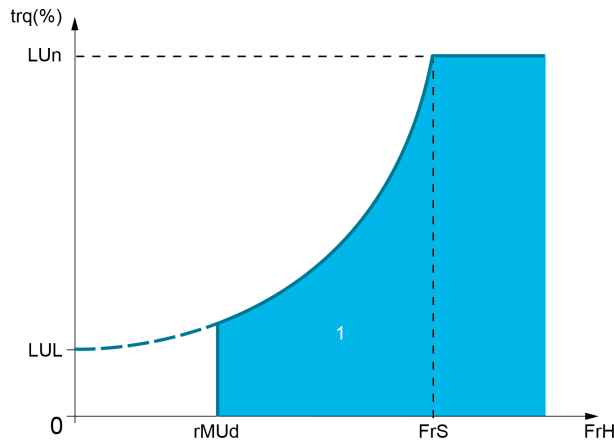

1 Underload zone.

A relay or a digital output can be assigned to the signaling of this detected error in the [Input/Output] i o -, [I/O assignment] i o R 5 - menus.

[Unld T. Del. Detect] u L t

Underload detection time delay.

It is reset to zero if the torque rises above the value of [Underload Threshold] L u L + 10% (hysteresis).

A value of 0 deactivates the function and makes the other parameters inaccessible.

Setting	Description
0...100 s	Setting range Factory setting: 0 s

[Unld.Thr.Nom.Speed] L u n ★

Underload threshold at nominal motor speed **[Nominal Motor Freq] F r 5**, as a % of the rated motor torque.

This parameter can be accessed if **[Unld T. Del. Detect] u L E** is not set to 0.

Setting ()	Description
20...100%	Setting range Factory setting: 60%

[Unld.Thr.0.Speed] L u L ★

Underload threshold at zero frequency as a % of the rated motor torque.

This parameter can be accessed if **[Unld T. Del. Detect] u L E** is not set to 0.

Setting ()	Description
0... [Unld.Thr.Nom.Speed] L u n	Setting range Factory setting: 0%

[Unld. FreqThr. Det.] r n u d ★

Minimum frequency underload detection threshold.

This parameter can be accessed if **[Unld T. Del. Detect] u L E** is not set to 0.

Setting ()	Description
0.0...500.0 Hz	Setting range Factory setting: 0.0 Hz

[Hysteresis Freq] S r b ★

Maximum deviation between the frequency reference and the motor frequency, which defines a steady state operation.

This parameter can be accessed if **[Unld T. Del. Detect] u L E** or **[Ovld Time Detect.] E o L** is not set to 0.

Setting ()	Description
0.3...500.0 Hz	Setting range Factory setting: 0.3 Hz

[Underload Mangmt.] u d L ★

Underload management.

Behavior on switching to underload detection.

This parameter can be accessed if **[Unld T. Del. Detect] u L E** is not set to 0.

Setting	Code / Value	Description
[Ignore]	<i>n o</i>	Detected error ignored
[Freewheel stop]	<i>Y E S</i>	Freewheel stop Factory setting
[Ramp stop]	<i>r P P</i>	Stop on ramp
[Fast stop]	<i>F S L</i>	Fast stop

[Underload T.B.Rest.] *F L U* ★

Minimum time permitted between an underload being detected and any automatic restart.

To allow an automatic restart, the value of **[Fault Reset Time]** *L R r* must exceed this parameter by at least 1 minute.

This parameter can be accessed if **[Underload Mangmt.]** *u d L* is not set to **[Ignore]** *n o*.

Setting ()	Description
0...6 min	Setting range Factory setting: 0 min

[Process overload] \square L d - Menu

Access

[Complete settings] \rightarrow [Generic monitoring] \rightarrow [Process overload]

About This Menu

A process overload error is detected when the next event occurs and remains pending for a minimum time [Ovld Time Detect.] t_{OL} , which is configurable:

- The drive is in [Current limitation] \llcorner L mode during acceleration, deceleration, or,
- The motor is in steady state and the [Motor Current] L \llcorner r is above the set overload threshold [Ovld Detection Thr.] L \square \llcorner .

The motor is in steady state when the offset difference between [Pre-Ramp Ref Freq] F r H and [Motor Frequency] r F r is less than the configurable threshold [Hysteresis Freq] S r b .

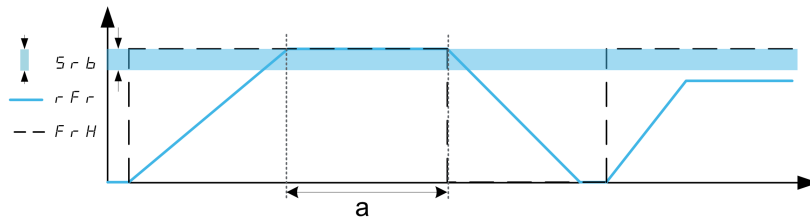

NOTE: Process overload monitoring is always active in [Current limitation] \llcorner L state.

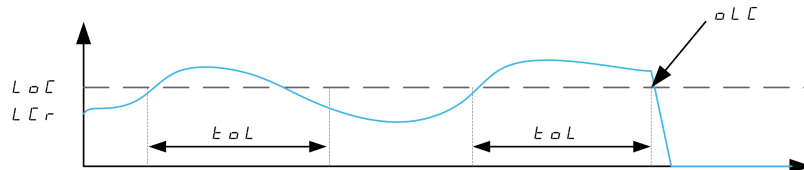

[Ovld Time Detect.] t_{OL}

Overload reaction time.

A value of 0 deactivates the function and makes the other parameters inaccessible.

Setting	Description
0...100 s	Setting range Factory setting: 0 s

[Ovld Detection Thr.] L \square \llcorner ★

Overload threshold.

Overload detection threshold, as a % of the rated motor current [Nom Motor Current] n \llcorner r . This value must be less than the limit current in order for the function to work.

This parameter can be accessed if [Ovld Time Detect.] t_{OL} is not set to 0.

Setting ()	Description
70...150%	Setting range Factory setting: 110%

[Hysteresis Freq] *S r b* ★

Hysteresis for steady state.

Maximum deviation between the frequency reference and the motor frequency, which defines a steady state operation.

This parameter can be accessed if **[Ovld Time Detect.] *U o L*** or **[Unld T. Del. Detect.] *U L L*** is not set to 0.

Setting ()	Description
0.3...500.0 Hz	Setting range Factory setting: 0.3 Hz

[Ovld.Proces.Mngmt] *o d L* ★

Behavior on switching to overload detection.

This parameter can be accessed if **[Ovld Time Detect.] *U o L*** is not set to 0.

Setting	Code / Value	Description
[Ignore]	<i>n o</i>	Detected error ignored
[Freewheel stop]	<i>Y E S</i>	Freewheel stop Factory setting
[Ramp stop]	<i>r P P</i>	Stop on ramp
[Fast stop]	<i>F S L</i>	Fast stop

[Overload T.B.Rest.] *F t o* ★

Minimum time permitted between an overload being detected and any automatic restart.

In order to allow an automatic restart, the value of **[Fault Reset Time] *L R r*** must exceed this parameter by at least 1 minute.

This parameter can be accessed if **[Ovld Time Detect.] *U o L*** or **[Ovld.Process.Mngmt] *o d L*** is not set to 0.

Setting ()	Description
0...6 min	Setting range Factory setting: 0 min

[Stall monitoring] 5 5 P 1 - Menu

Access

[Complete settings] → [Generic monitoring] → [Stall monitoring]

About This Menu

This function helps to prevent a motor overload by monitoring the motor current and the speed rise time.

A stalling condition is when:

- An output frequency is smaller than the stalling frequency [**Stall Frequency**] 5 5 P 3
- And an output current is higher than the stalling current [**Stall Current**] 5 5 P 2
- During a time longer than the stalling time [**Stall Max Time**] 5 5 P 1

When a stalling condition occurs, a [**Motor Stall Error**] 5 5 F error is triggered.

[Stall Monitoring] 5 5 P 1

Stall monitoring activation.

Setting	Code / Value	Description
[No]	n o	Function disabled Factory setting
[Yes]	y e s	Function enabled

[Stall Max Time] 5 5 P 1★

Motor stall maximum time.

This parameter can be accessed if [**Stall Monitoring**] 5 5 P 1 is not set to [**No**] n o.

Setting ()	Description
0.0...200 s	Setting range Factory setting: 60.0 s

[Stall Current] 5 5 P 2★

Stall monitoring current level, as a % of the rated motor current. ([**Nom Motor Current**] n c r or [**Sync Nominal I**] n c r 5, depending on the motor control type.)

This parameter can be accessed if [**Stall Monitoring**] 5 5 P 1 is not set to [**No**] n o.

The factory setting changes to 150.0 % if [**Dual rating**] d r t is set to [**Heavy Duty**] H i G h.

Setting ()	Description
0.0...120.0%	Setting range Factory setting: 150.0%

[Stall Frequency] 5 5 P 3★

Stall monitoring frequency level.

This parameter can be accessed if **[Stall Monitoring] 5 5 P 1** is not set to **[No]** *n o*.

Setting ()	Description
0.0... [Max Frequency] 5 5 F r	Setting range Factory setting: 2.0 Hz

[Thermal monitoring] 5 - Menu

Access

[Complete settings] → [Generic monitoring] → [Thermal monitoring]

About This Menu

Identical to [Thermal monitoring] 5 - Menu , page 165.

[Input/Output] - [I/O assignment]

[DI1 assignment] L I R - to [DI6 assignment] L E R - Menus

Access

[Complete settings] → [Input/Output] → [I/O assignment] → [DI6 assignment]

[DI1 Low Assignment] L I L to [DI6 Low Assignment] L E L

DI1 low assignment to DI6 low assignment.

Read-only parameter, cannot be configured. It displays all the functions associated with digital input in order to verify, for example, for compatibility problems.

If no functions have been assigned, **[No]** n o is displayed.

[DI1 High Assignment] L I H to [DI6 High Assignment] L E H

DI1 high assignment to DI6 high assignment.

Read-only parameter, cannot be configured. It displays all the functions associated with digital input in order to verify, for example, for compatibility problems.

If no functions have been assigned, **[No]** n o is displayed.

[DI11 assignment] L I I R - to [DI16 assignment] L I E R - Menus

Access

[Complete settings] → [Input/Output] → [I/O assignment] → [DI11 assignment] to [DI16 assignment]

About These Menus

Identical to [DI1 assignment] L I R - menu , page 487.

These menus can be accessed if VW3A3203 I/O extension module has been inserted.

[DI11 Low Assignment] L I I L to [DI16 Low Assignment] L I E L ★

DI11 to DI16 low assignment.

Read-only parameters, cannot be configured. It displays all the functions associated with the digital input in order to verify, for example, for compatibility problems.

If no functions have been assigned, [No] n o is displayed.

[DI11 High Assignment] L I I H to [DI16 High Assignment] L I E H ★

DI11 to DI16 high assignment.

Read-only parameters, cannot be configured. It displays all the functions associated with the digital input in order to verify, for example, for compatibility problems. If no functions have been assigned, [No] n o is displayed.

[DI5 Pulse Input Assign] P , 5 R - Menu

Access

[Complete settings] → [Input/Output] → [I/O assignment] → [DI5 Pulse Input Assign]

About This Menu

Following parameters can be accessed on the Graphic Display Terminal by pressing the OK key on the [DI5 Frequency Measured] $P F \llcorner 5$ parameter.

[DI5 Pulse Input Assign] P , 5 R

DI5 pulse input assignment.

It displays all the functions associated with the pulse input in order to verify, for example, for compatibility problems.

If no functions have been assigned, [No] $n \square$ is displayed.

[DI6 Pulse Input Assign] P , 6 R - Menu

Access

[Complete settings] → [Input/Output] → [I/O assignment] → [Pulse Input DI6 Assign]

About This Menu

Identical to [DI5 Pulse Input Assign] P , 5 R - .

Following parameters can be accessed on the Graphic Display Terminal by pressing the OK key on the [DI6 Frequency Measured] $P F \llcorner 6$ parameter.

[Pulse Input DI6 Assign] P , 6 R

Pulse Input DI6 Assignment.

[AI1 assignment] $\text{A} \text{I} \text{1}$ - to [AI5 assignment] $\text{A} \text{I} \text{5}$ - Menus

Access

[Complete settings] \rightarrow [Input/Output] \rightarrow [I/O assignment] \rightarrow [AI1 assignment] to [AI5 assignment]

About These Menus

AI4 and AI5 can be accessed if VW3A3203 I/O extension module has been inserted.

[AI1 Assignment] $\text{A} \text{I} \text{1}$ to [AI5 Assignment] $\text{A} \text{I} \text{5}$

Analog input AI1 functions assignment to Analog input AI5 functions assignment.

Read-only parameter, cannot be configured. It displays all the functions associated the related analog input in order to verify, for example, for compatibility problems.

If no functions have been assigned, [No] $\text{n} \text{o}$ is displayed.

[AIV1 assignment] $\text{A} \text{V} \text{1}$ - to [AIV3 assignment] $\text{A} \text{V} \text{3}$ - Menus

Access

[Complete settings] \rightarrow [Input/Output] \rightarrow [I/O assignment] \rightarrow [AIV1 assignment]

[AIV1 assignment] $\text{A} \text{V} \text{1}$ - to [AIV3 assignment] $\text{A} \text{V} \text{3}$ -

Virtual analog input function assignment.

Read-only parameter, cannot be configured. It displays all the functions associated with the related virtual analog input in order to verify, for example, for compatibility problems. If no functions have been assigned, [No] $\text{n} \text{o}$ is displayed.

[DI50 Assignment] $\mathcal{d} \mathcal{S} \mathcal{D} \mathcal{A}$ - to [DI59 Assignment] $\mathcal{d} \mathcal{S} \mathcal{9} \mathcal{A}$ - Menus

Access

[Complete settings] \rightarrow [Input/Output] \rightarrow [I/O assignment] \rightarrow [DI50 Assignment] to [DI59 Assignment]

About These Menus

These menus can be accessed on ATV●30●●●F, ATV●50●●●F, ATV●60, ATV●80, and ATV●L0, equipped with cabinet IO, and if [Access Level] $\mathcal{L} \mathcal{A} \mathcal{C}$ is set to [Expert] $\mathcal{E} \mathcal{P} \mathcal{r}$.

[DI50 Low Assignment] $\mathcal{d} \mathcal{S} \mathcal{D} \mathcal{L}$ to [DI59 Low Assignment] $\mathcal{d} \mathcal{S} \mathcal{9} \mathcal{L}$

DI50 to DI59 low assignment.

NOTE: The factory setting value of D51L is modified to [Cabinet Overheat] $\mathcal{L} \mathcal{C} \mathcal{O}$ on ATV●30●●●F, ATV●50●●●F, ATV●60, ATV●80, and ATV●L0.

[DI50 High Assignment] $\mathcal{d} \mathcal{S} \mathcal{D} \mathcal{H}$ to [DI59 High Assignment] $\mathcal{d} \mathcal{S} \mathcal{9} \mathcal{H}$

DI50 to DI59 high assignment.

[Input/Output] - [DI/DQ]

[DI1 Configuration] d , 1 - to [DI6 Configuration] d , 6 - Menus

Access

[Complete settings] → [Input/Output] → [DI/DQ] → [DI1 Configuration] to [DI6 Configuration]

[DI1 Low Assignment] L 1 L to [DI6 Low Assignment] L 6 L

DI1 to DI6 low assignment.

Read-only parameter, cannot be configured. It displays all the functions associated with the related digital input in order to verify, for example, for compatibility problems.

If no functions have been assigned, **[No]** n o is displayed.

[DI1 High Assignment] L 1 H to [DI6 High Assignment] L 6 H

DI1 to DI6 high assignment.

Read-only parameter, cannot be configured. It displays all the functions associated with the related digital input in order to verify, for example, for compatibility problems.

If no functions have been assigned, **[No]** n o is displayed.

The digital input DI1 is assigned to:

- **[Forward]** F r d in 2-wire control
- **[Run]** r u n in 3-wire control.

[Run] r u n and **[Forward]** F r d settings cannot be modified manually.

NOTE: In IO profile, the assignment of **[Run]** r u n (respectively **[Forward]** F r d) switches to **[CD00]** C d 0 0 in 2-wire control (respectively 3-wire control).

The digital input DI2 is assigned to **[Forward]** F r d in 3-wire control. **[Forward]** F r d setting cannot be modified manually.

NOTE: In IO profile, the assignment of **[Forward]** F r d switches to **[CD01]** C d 0 1 in 3-wire control.

[DI1 Delay] L 1 d to [DI6 Delay] L 6 d

DI1 to DI6 delay.

NOTE: Commands received via this digital input are processed once the delay time set via this parameter has elapsed.

Setting	Description
0...200 ms	Setting range Factory setting: 5 ms

[DI11 Configuration] d , / / - to [DI16 Configuration] Menus

Access

[Complete settings] → [Input/Output] → [DI/DQ] → [DI11 Configuration] to [DI16 Configuration]

About These Menus

Identical to [DI1 Configuration] d , / / - menu , page 492.

These menus can be accessed if VW3A3203 I/O extension module has been inserted.

[DI11 Low Assignment] L / / L to [DI16 Low Assignment] L / B L ★

DI11 to DI16 low assignment.

[DI11 High Assignment] L / / H to [DI16 High Assignment] L / B H ★

DI11 to DI16 high assignment.

[DI11 Delay] L / / d to [DI16 Delay] L / B d ★

DI11 to DI16 delay.

[DI5 Pulse Config] $P A$, 5 - Menu

Access

[Complete settings] \rightarrow [Input/Output] \rightarrow [DI/DQ] \rightarrow [DI5 Pulse Config]

About This Menu

Following parameters can be accessed on the Graphic Display Terminal by pressing the **OK** key on the [DI5 Frequency Measured] $P F \llcorner 5$ parameter.

[DI5 Pulse Input Assign] P , $5 A$

DI5 pulse input assignment.

It displays all the functions associated with the pulse input in order to verify, for example, for compatibility problems.

If no functions have been assigned, **[No]** $n o$ is displayed.

[DI5 PulseInput Low Freq] P , $L 5$

DI5 pulse input low frequency.

Pulse input scaling parameter of 0% in Hz x 10 unit.

Setting	Description
0.00...30000.00 Hz	Setting range Factory setting: 0.00 Hz

[DI5 PulseInput High Freq] P , $H 5$

DI5 pulse input high frequency.

Pulse input scaling parameter of 100% in Hz x 10 unit.

Setting	Description
0.00...30.00 kHz	Setting range Factory setting: 30.00 kHz

[DI5 Frequency Filter] $P F$, 5

Interference filtering pulse input cut-off time of the low-filter.

Setting	Description
0...1,000 ms	Setting range Factory setting: 0 ms

[DI6 Pulse Config] $P R$, \llcorner - Menu

Access

[Complete settings] \rightarrow [Input/Output] \rightarrow [DI/DQ] \rightarrow [DI6 Pulse Config]

About This Menu

Following parameters can be accessed on the Graphic Display Terminal by pressing the **OK** key on the **[DI6 Frequency Measured]** $P F \llcorner \llcorner$ parameter.

[DI6 Pulse Input Assign] P , $\llcorner R$

Filtered customer pulse input frequency reference.

Identical to **[DI5 Pulse Input Assign]** P , $5 R$.

[DI6 PulseInput Low Freq] P , $L \llcorner$

DI6 pulse input low frequency.

Identical to **[DI5 PulseInput Low Freq]** P , $L 5$.

[DI6 PulseInput High Freq] P , $H \llcorner$

DI6 pulse input high frequency.

Identical to **[DI5 PulseInput High Freq]** P , $H 5$.

[DI6 Frequency Filter] $P F$, \llcorner

Interference filtering pulse input cut-off time of the low-filter.

Identical to **[DI5 Frequency Filter]** $P F$, 5 .

[DQxx Configuration] d o X X - Menu

Access

[Complete settings] → [Input/Output] → [DI/DQ] → [DQxx Configuration]

About This Menu

These menus are used to configure the digital outputs of the drive:

- **[DQ11 Configuration] d o 1 1 -** and **[DQ12 Configuration] d o 1 2 -**: the digital output DQ11 and DQ12 if the VW3A3203 Extended I/O option module is inserted.

Use the touch wheel to scroll through the digital outputs. Click OK to access the configuration of the digital output.

On Graphic Display Terminal, if an output is assigned then a check mark is displayed.

For a given digital output (DQxx), the configuration is composed by:

- **[DQxx Assignment] d o X X**: the assignment of the digital output DQxx,
- **[DQxx Delay time] d X X d**: the delay time of the digital output DQxx. It represents the delay before modifying the state of the output when the assigned event becomes true,
- **[DQxx Active at] d X X S**: the active level of the digital output DQxx. It defines the state 1 or 0 of the output to the "True" state of the assigned event.
- **[DQxx Holding time] d X X H**: the holding time of the digital output DQxx. It represents the delay before modifying the state of the output when the assigned event becomes false.
- **[Enable DQxx fallback] d X X F / L o X F**: parameter used to enable/disable the fallback mode triggered in case of communication interruption (if the output is controlled by fieldbus communication).

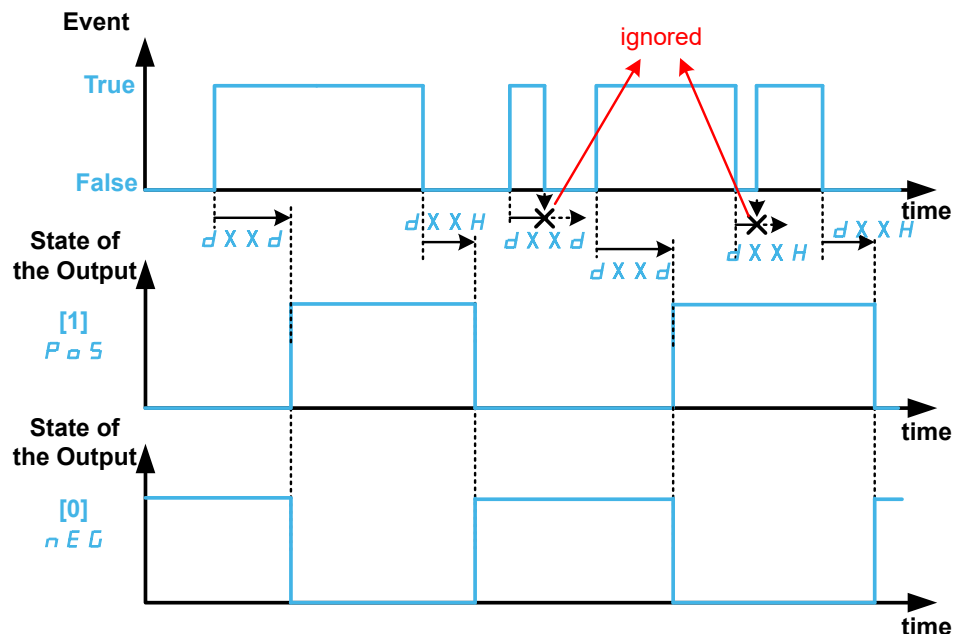

[DQxx Assignment] d o X X ★

[DQ11 Assignment] d o 1 1, **[DQ12 Assignment] d o 1 2**

Digital output xx assignment.

It is used to assign an output to an event or a function.

Possible settings: Identical to [Rx Assignment] r X Menus, page 520.

If the output is set to [CDxx] CDxx or [Cxxx] Cxxx and has been enabled, transition to operating state Fault such as, but not limited to, communication interruption, will not disable the output.

▲ WARNING
<p>LOSS OF CONTROL</p> <p>Only set the output to [CDxx] CDxx or [Cxxx] Cxxx after having verified that this setting cannot result in unsafe conditions including communication interruption.</p> <p>Failure to follow these instructions can result in death, serious injury, or equipment damage.</p>

[DQxx Delay time] d X X d★

DQxx activation delay time.

[DQ11 Delay time] d 1 1 d, [DQ12 Delay time] d 1 2 d

It represents the delay before modifying the state of the output when the assigned event becomes true.

If the corresponding output is assigned to one of the following assignments, the delay is forced to 0 ms and it cannot be modified:

- [Operating State “Fault”] F L E ,
- [Mains Contactor] L L C ,
- [Output Cont] o C C ,
- [Priming] P r , П ,
- [Jockey] J o K Y ,
- [Pump 1 Cmd] П P o 1...[Pump 6 Cmd] П P o 6 ,
- [M/P Master Activated] П P П A .

Setting	Description
0...60,000 ms (step: 1 ms)	Setting range: 0...9,999 ms then 10.00...60.00 s on the Graphic Display Terminal . Factory setting: 0 ms

[DQxx Active at] d X X 5★

[DQ11 Active at] d 1 1 5, [DQ12 Active at] d 1 2 5

DQxx status (output active level)

It defines the state 1 or 0 of the output to the “True” state of the assigned event.

If the output is assigned to one of the following assignments, the delay is forced to [1] Pos:

- [Operating State “Fault”] F L E ,
- [Mains Contactor] L L C ,
- [Output Cont] o C C ,
- [Priming] P r , П ,
- [Jockey] J o K Y ,
- [Pump 1 Cmd] П P o 1...[Pump 6 Cmd] П P o 6 ,
- [M/P Master Activated] П P П A .

Setting	Code / Value	Description
[1]	<i>P o S</i>	State 1 if the event is true. Factory Setting
[0]	<i>n E G</i>	State 0 if the event is true.

[DQxx Holding time] *d X X H*★

[DQ11 Holding time] *d 1 1 H*, [DQ12 Holding time] *d 1 2 H*

DQxx holding delay time.

It represents the delay before modifying the state of the output when the assigned event becomes false.

If the corresponding output is assigned to one of the following assignments, the delay is forced to 0 ms and it cannot be modified:

- **[Operating State "Fault"]** *F L E*,
- **[Mains Contactor]** *L L C*,
- **[Output Cont]** *o C C*,
- **[Priming]** *P r i n*,
- **[Jockey]** *J o c k y*,
- **[Pump 1 Cmd]** *Π P o 1*...**[Pump 6 Cmd]** *Π P o 6*,
- **[M/P Master Activated]** *Π P Π R*.

Setting	Description
0...9,999 ms (step: 1 ms)	Setting range Factory setting: 0 ms

[Enable DQxx fallback] *L o X F / d X X F*

[Enable DQ11 fallback] *d 1 1 F*, [Enable DQ12 fallback] *d 1 2 F*

Enable DQxx fallback.

[Enable DQ11 fallback] *d 1 1 F* (respectively [Enable DQ12 fallback] *d 1 2 F*) is forced to **[No]** *n o* if **[DQ11 Assignment]** *d o 1 1* (respectively **[DQ12 Assignment]** *d o 1 2*) is assigned.

If the output is controlled by fieldbus and has been enabled, transition to operating state Fault such as, but not limited to, communication interruption, will not disable the output if this parameter is set to **[No]** *n o*.

⚠ WARNING

LOSS OF CONTROL

- Verify that using this default setting does not result in unsafe conditions including communication interruption.
- Set this parameter to **[Yes]** *y e s* to disable the output if an error is triggered.

Failure to follow these instructions can result in death, serious injury, or equipment damage.

Setting	Code / Value	Description
[No]	00	<p>Fallback feature disabled.</p> <p>When the output is assigned, the output value is defined according to its assignment, page 496.</p> <p>When the output is not assigned, the state of the output can be controlled via a bit of <code>OL1r</code>. If an error is triggered, the output remains unchanged.</p> <p>Factory setting</p>
[Yes]	55	<p>Fallback feature enabled.</p> <p>The state of the output is controlled via a bit of <code>OL1r</code> (refer to the communication parameter addresses file). If an error is detected, the output is disabled.</p> <p>NOTE: If an error is detected, the process applied on the output (e.g. delays, active level) remains applied.</p>

[DI50 Configuration] *d 5 0 -* to [DI59 Configuration] *d 5 9 -* Menus

Access

[Complete settings] → [Input/Output] → [DI/DQ] → [DI50 Configuration] to [DI59 Configuration]

About These Menus

Following parameters can be accessed on ATV660 or ATV680, equipped with cabinet IO, and if [Access Level] *L A C* is set to [Expert] *E P r*.

NOTE: DI50 up to DI59 Inputs are used inside the Drive Systems enclosure for control and monitoring circuits.

[DI50 Low Assignment] *d 5 0 L* to [DI59 Low Assignment] *d 5 9 L*

DI50 to DI59 low assignment.

Read-only parameters, cannot be configured. It displays all the functions associated with the cabinet digital input in order to verify, for example, for compatibility problems.

If no functions have been assigned, [No] *n o* is displayed.

[DI50 High Assignment] *d 5 0 H* to [DI59 High Assignment] *d 5 9 H*

DI50 to DI59 high assignment.

Read-only parameters, cannot be configured. It displays all the functions associated with the cabinet digital input in order to verify, for example, for compatibility problems.

If no functions have been assigned, [No] *n o* is displayed.

[DI50 delay] *d 5 0 d* to [DI59 delay] *d 5 9 d*

DI50 to DI59 delay.

NOTE: Commands received via this digital input are processed once the delay time set via this parameter has elapsed.

Setting	Description
0...200 ms	Setting range Factory setting: 2 ms

[Input/Output] - [Analog I/O]

[AI1 configuration] R , I - Menu

Access

[Complete settings] → [Input/Output] → [AI/AQ] → [AI1 configuration]

About This Menu

The input can be delinearized by configuring an intermediate point on the input/output curve of this input:

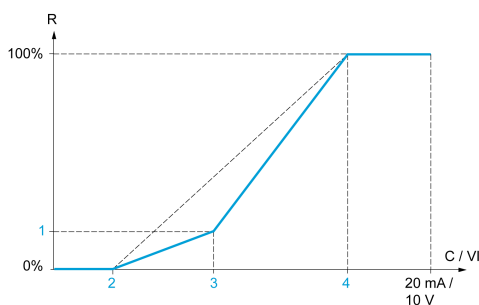

R Reference

C / VI Current or Voltage Input

1 [Y Interm. point]

2 [Min value] (0%)

3 [X Interm. point]

4 [Max value] (100%)

NOTE: For [X Interm. point], 0% corresponds to [Min value] and 100% to [Max value].

[AI1 Assignment] R , I R

Analog input AI1 functions assignment.

Read-only parameter, cannot be configured. It displays all the functions associated with input AI1 in order to verify, for example, for compatibility problems.

If no functions have been assigned, [No] is displayed.

[AI1 Type] R , I E

Configuration of analog input AI1.

Setting	Code / Value	Description
[Voltage]	I D u	0-10 Vdc Factory setting
[Current]	D R	0-20 mA
[PTC Management]	P E C	1 to 6 PTC (in serial)
[KTY]	K E Y	1 KTY84

Setting	Code / Value	Description
[PT100]	IP E 2	1 PT100 connected with 2 wires
[PT1000]	IP E 3	1 PT1000 connected with 2 wires

[AI1 Min. value] U , L I★

AI1 voltage scaling parameter of 0%.

This parameter can be accessed if [AI1 Type] R , I E is set to [Voltage] I D U .

Setting	Description
0.0...10.0 Vdc	Setting range Factory setting: 0.0 Vdc

[AI1 Max. value] U , H I★

AI1 voltage scaling parameter of 100%.

This parameter can be accessed if [AI1 Type] R , I E is set to [Voltage] I D U .

Setting	Description
0.0...10.0 Vdc	Setting range Factory setting: 10.0 Vdc

[AI1 Min. value] C r L I★

AI1 current scaling parameter of 0%.

This parameter can be accessed if [AI1 Type] R , I E is set to [Current] D R .

Setting	Description
0.0...20.0 mA	Setting range Factory setting: 0.0 mA

[AI1 Max. value] C r H I★

AI1 current scaling parameter of 100%.

This parameter can be accessed if [AI1 Type] R , I E is set to [Current] D R .

Setting	Description
0.0...20.0 mA	Setting range Factory setting: 20.0 mA

[AI1 filter] R , I F

AI1 cutoff time of the low filter.

Setting ()	Description
0.00...10.00 s	Setting range Factory setting: 0.00 s

[AI1 Interm. point X] R , IE

Input delinearization point coordinate. Percentage of the physical input signal.

0% corresponds to [AI1 min value] (\llcorner IL)

100% corresponds to [AI1 max value] (\llcorner IH)

Setting 	Description
0...100%	Setting range Factory setting: 0%

[AI1 Interm. point Y] R , IS

Input delinearization point coordinate (frequency reference).

Percentage of the internal frequency reference corresponding to the [AI1 Interm. point X] (R , IE) percentage of physical input signal.

Setting 	Description
0...100%	Setting range Factory setting: 0%

[AI1 Range] R , IL

AI1 scaling selection.

This parameter can be accessed if [AI1 Type] R , IE is set to [Current] DR .

This parameter is forced to [0-100%] POS if:

- [AI1 Type] R , IE is not set to [Current] DR , or
- [AI1 min. value] CLL is lower than 3.0 mA

Setting	Code / Value	Description
[0-100%]	POS	Unidirectional: AI1 current scaling is 0% up to 100%. Factory Setting
[+/-100%]	$POSNEG$	Bidirectional: AI1 current scaling is -100% up to 100%. [AI1 min. value] CLL corresponds to -100%. [AI1 max. value] CHL corresponds to 100%.

[AI2 configuration] *A , 2* - Menu

Access

[Complete settings] → [Input/Output] → [AI/AQ] → [AI2 configuration]

[AI2 Assignment] *A , 2 A*

AI2 functions assignment.

Identical to [AI1 Assignment] *A , 1 A*, page 501.

[AI2 Type] *A , 2 E*

Configuration of analog input AI2.

Setting	Code / Value	Description
[Voltage]	<i>1 0 U</i>	0-10 Vdc Factory setting
[Current]	<i>0 A</i>	0-20 mA
[PTC Management]	<i>P E C</i>	1 to 6 PTC (in serial)
[KTY]	<i>K E Y</i>	1 KTY84
[PT1000]	<i>1 P E 3</i>	1 PT1000 connected with 2 wires
[PT100]	<i>1 P E 2</i>	1 PT100 connected with 2 wires
[Water Prob]	<i>L E U E L</i>	Water level
[3PT1000]	<i>3 P E 3</i>	3 PT1000 connected with 2 wires
[3PT100]	<i>3 P E 2</i>	3 PT100 connected with 2 wires

[AI2 min value] *U , L 2*★

AI2 voltage scaling parameter of 0%.

This parameter can be accessed if [AI2 Type] *A , 2 E* is set to [Voltage] *1 0 U*.

Identical to [AI1 min value] *U , L 1*, page 502.

[AI2 Max .value] *U , H 2*★

AI2 voltage scaling parameter of 100%.

This parameter can be accessed if [AI2 Type] *A , 2 E* is set to [Voltage] *1 0 U*.

Identical to [AI1 Max. value] *U , H 1*, page 502.

[AI2 Min. value] *C r L 2*★

AI2 current scaling parameter of 0%.

This parameter can be accessed if [AI2 Type] *A , 2 E* is set to [Current] *0 A*.

Identical to [AI1 Min. value] *C r L 1*, page 502.

[AI2 Max. value] C r H 2★

AI2 current scaling parameter of 100%.

This parameter can be accessed if [AI2 Type] R , 2 E is set to [Current] 0 R.

Identical to [AI1 Max. value] C r H 1 , page 502.

[AI2 filter] R , 2 F

AI2 filter.

Identical to [AI1 filter] R , 1 F , page 502.

[AI2 Interm. point X] R , 2 E

AI2 delinearization input level.

Identical to [AI1 Interm. point X] R , 1 E , page 503.

[AI2 Interm. point Y] R , 2 S

AI2 delinearization output level.

Identical to [AI1 Interm. point Y] R , 1 S , page 503.

[AI2 Range] R , 2 L

AI2 scaling selection.

This parameter can be accessed if [AI2 Type] R , 2 E is set to [Current] 0 R.

Identical to [AI1 Type] R , 1 E , page 505

[AI3 configuration] R , 3 - Menu

Access

[Complete settings] → [Input/Output] → [AI/AQ] → [AI3 configuration]

[AI3 Assignment] R , 3 R

AI3 functions assignment.

Identical to [AI1 Assignment] R , 1 R , page 501.

[AI3 Type] R , 3 E

Configuration of analog input AI3.

Identical to [AI2 Type] R , 2 E , page 504 with factory setting: [Current] 0 R .

[AI3 Min. value] U , L 3 ★

AI3 voltage scaling parameter of 0%.

Identical to [AI1 Min. value] U , L 1 , page 502.

This parameter can be accessed if [AI3 Type] R , 3 E is set to [Voltage] 1 0 U .

[AI3 Max. value] U , H 3 ★

AI3 voltage scaling parameter of 100%.

Identical to [AI1 Max. value] U , H 1 , page 502.

This parameter can be accessed if [AI3 Type] R , 3 E is set to [Voltage] 1 0 U .

[AI3 Min. value] C r L 3 ★

AI3 current scaling parameter of 0%.

Identical to [AI1 Min. value] C r L 1 , page 502.

This parameter can be accessed if [AI3 Type] R , 3 E is set to [Current] 0 R .

[AI3 Max. value] C r H 3 ★

AI3 current scaling parameter of 100%.

Identical to [AI1 Max. value] C r H 1 , page 502.

This parameter can be accessed if [AI3 Type] R , 3 E is set to [Current] 0 R .

[AI3 filter] R , 3 F

AI3 cutoff time of the low filter.

Identical to [AI1 filter] R , 1 F , page 502.

[AI3 X Interm. point] R , 3 E

AI3 delinearization input level.

Identical to [AI1 Interm. point X] R , 1 E , page 503.

[AI3 Y Interm. point] R , 3 S

AI3 delinearization output level.

Identical to [AI1 Interm. point Y] R , 1 S , page 503.

[AI3 Range] R , 3 L

AI3 scaling selection.

This parameter can be accessed if [AI3 Type] R , 3 E is set to [Current] 0 R.

Identical to [AI1 Type] R , 1 E , page 507

[AI4 configuration] R , 4 - Menu

Access

[Complete settings] → [Input/Output] → [AI/AQ] → [AI4 configuration]

[AI4 Assignment] R , 4 R★

AI4 functions assignment.

This parameter can be accessed if VW3A3203 I/O extension module has been inserted.

Identical to [AI1 Assignment] R , 1 R , page 501.

[AI4 Type] R , 4 E★

Configuration of analog input AI4.

This parameter can be accessed if VW3A3203 I/O extension module has been inserted.

Setting	Code / Value	Description
[Voltage]	1 0 u	0-10 Vdc
[Current]	0 R	0-20 mA
[Voltage +/-]	n 1 0 u	-10/+10 Vdc Factory setting

[AI4 Min value] u , L 4★

AI4 voltage scaling parameter of 0%.

Identical to [AI1 Min value] u , L 1 , page 502.

[AI4 Max. value] u , H 4★

AI4 voltage scaling parameter of 100%.

Identical to [AI1 Max. value] u , H 1 , page 502.

[AI4 Min. value] C r L 4★

AI4 current scaling parameter of 0%.

Identical to [AI1 Min. value] C r L 1 , page 502.

[AI4 Max. value] C r H 4★

AI4 current scaling parameter of 100%.

Identical to [AI1 Max. value] C r H 1 , page 502.

[AI4 filter] R , 4 F★

AI4 cutoff time of the low filter.

This parameter can be accessed if VW3A3203 I/O extension module has been inserted.

Identical to **[AI1 filter] R , 1 F** , page 502.

[AI4 X Interm. point] R , 4 E ★

AI4 delinearization input level.

This parameter can be accessed if VW3A3203 I/O extension module has been inserted.

Identical to **[AI1 Interm. point X] R , 1 E** , page 503.

[AI4 Y Interm. point] R , 4 S ★

AI4 delinearization output level.

This parameter can be accessed if VW3A3203 I/O extension module has been inserted.

Identical to **[AI1 Interm. point Y] R , 1 S** , page 503.

[AI4 Range] R , 4 L

AI4 scaling selection.

This parameter can be accessed if **[AI4 Type] R , 4 E** is set to **[Current] 0 R**.

Identical to **[AI1 Type] R , 1 E** , page 509

[AI5 configuration] R , 5 - Menu

Access

[Complete settings] → [Input/Output] → [AI/AQ] → [AI5 configuration]

[AI5 Assignment] R , 5 R★

AI5 functions assignment.

This parameter can be accessed if VW3A3203 I/O extension module has been inserted.

Identical to [AI1 Assignment] R , 1 R , page 501.

[AI5 Type] R , 5 E★

Configuration of analog input AI5.

This parameter can be accessed if VW3A3203 I/O extension module has been inserted.

Identical to [AI4 Type] R , 4 E , , page 508

[AI5 Min. value] U , L 5★

AI5 voltage scaling parameter of 0%.

Identical to [AI1 Min. value] U , L 1 , page 502.

[AI5 Max. value] U , H 5★

AI5 voltage scaling parameter of 100%.

Identical to [AI1 Max. value] U , H 1 , page 502.

[AI5 Min. value] C r L 5★

AI5 current scaling parameter of 0%.

Identical to [AI1 Min. value] C r L 1 , page 502.

[AI5 Max. value] C r H 5★

AI5 current scaling parameter of 100%.

Identical to [AI1 Max. value] C r H 1 , page 502.

[AI5 filter] R , 5 F★

AI5 cutoff time of the low filter.

This parameter can be accessed if VW3A3203 I/O extension module has been inserted.

Identical to [AI1 filter] R , 1 F , page 502.

[AI5 X Interm. point] 5 5 ★

AI5 delinearization input level.

This parameter can be accessed if VW3A3203 I/O extension module has been inserted.

Identical to **[AI1 Interm. point X] 5 5**, page 503.

[AI5 Y Interm. point] 5 5 ★

AI5 delinearization output level.

This parameter can be accessed if VW3A3203 I/O extension module has been inserted.

Identical to **[AI1 Interm. point Y] 5 5**, page 503.

[AI5 Range] 5 5

AI5 scaling selection.

This parameter can be accessed if **[AI5 Type] 5 5** is set to **[Current] 0 5**.

Identical to **[AI1 Type] 5 5**, page 511

[AQ1 configuration] *A 0 1* - Menu

Access

[Complete settings] → [Input/Output] → [AI/AQ] → [AQ1 configuration]

Minimum and Maximum Output Values

The minimum output value, in volts, corresponds to the lower limit of the assigned parameter and the maximum value corresponds to its upper limit. The minimum value may be greater than the maximum value.

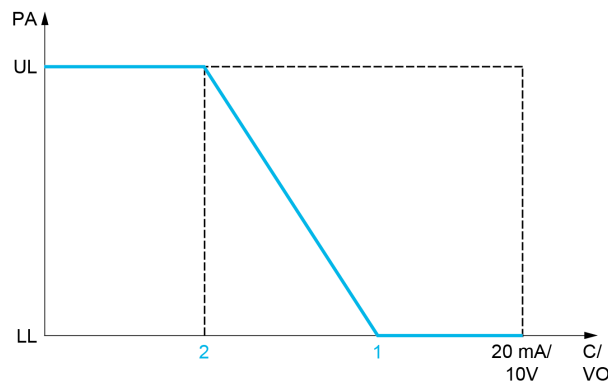
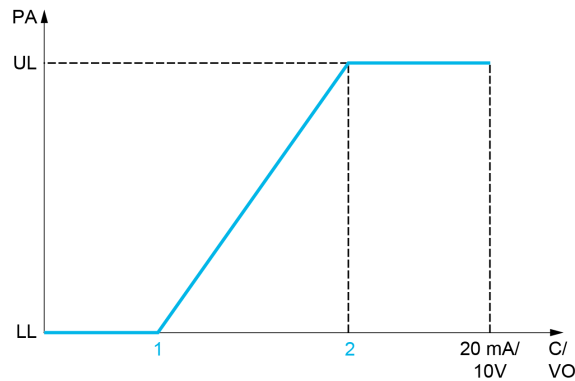

PA Parameter assigned

C / VO Current or voltage output

UL Upper limit

LL Lower limit

1 [Min Output] *A 0 L X* or *u 0 L X*

2 [Max Output] *A 0 H X* or *u 0 H X*

Scaling of the Assigned Parameter

The scale of the assigned parameter can be adapted in accordance with the requirements by modifying the values of the lower and upper limits with two parameters for each analog output (**[Scaling AQx min]** *A 5 L X* and **[Scaling AQx max]** *A 5 H X*).

These parameters are given in %. 100 % corresponds to the total variation range of the configured parameter, so: 100% = upper limit - lower limit.

For example, **[Sign. torque]** *5 5 9* which varies between -3 and +3 times the rated torque, 100% corresponds to 6 times the rated torque.

- The **[Scaling AQx min] R 5 L X** parameter modifies the lower limit: new value = lower limit + (range x R 5 L X). The value 0% (factory setting) does not modify the lower limit.
- The **[Scaling AQx max] R 5 H X** parameter modifies the upper limit: new value = lower limit + (range x R 5 H X). The value 100% (factory setting) does not modify the upper limit.
- **[Scaling AQx min] R 5 L X** must always be lower than **[Scaling AQx max] R 5 H X**.

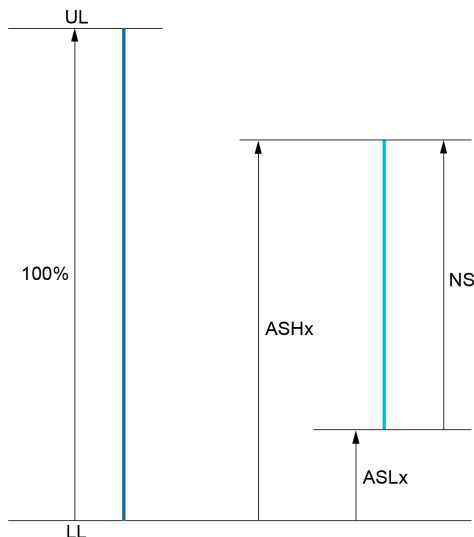

UL Upper limit of the assigned parameter

LL Lower limit of the assigned parameter

NS New scale

1 R 5 H X

2 R 5 L X

Application Example

In an application, it is requested to read on the analog output AQ1 the value of the motor current. The value must in current (0...20 mA) and the full range must correspond to 0 up to 2 x nominal motor current (2 x In motor).

In this example, In motor corresponds to 0.8 x In drive.

Consequently, the analog output AQ1 must be configured as following:

- Set **[AQ1 Assignment] R 0 I** to **[Motor Current] 0 C r**. By default, the total variation range is 0 to 2 times the nominal drive current (2 x In drive).
- Set **[AQ1 Type] R 0 I t** to **[Current] 0 R**. Then, set **[AQ1 min output] R 0 L I** and **[AQ1 max output] R 0 H I**. By default, they are equal to 0.0 mA and 20.0 mA, that is corresponding to the requirements.
- The requested minimum value is 0 A (0 x In motor = 0 x In drive): **[Scaling AQ1 min] R 5 L I** does not need to be modified (its factory setting is 0 %).
- The requested total variation range is 2 x In motor (= 1.6 x In drive). By default, the full range for **[Motor Current] 0 C r** is 2 x In drive. It means that the requested total variation range must be reduced to 80 % (1.6/2 = 0.8). Consequently, **[Scaling AQ1 max] R 5 H I** must be set to 80 %.

[AQ1 Assignment] R 0 I

AQ1 assignment.

Setting	Code / Value	Description
[Not Configured]	n o	Not assigned NOTE: In this case, the output can be controlled via the internal parameter $R o I r$ (refer to the communication parameter addresses file). By default, if an error (such as a communication interruption) is detected, the output remains unchanged. Use the parameter [Enable AQ1 fallback] $R o F I$ to disable the output in case of error detection.
[Installation Flow]	F S I u	Installation flow value
[Mixing Valve]	n V C o	External mixing valve command signal determined according to the cooling liquid temperature. Value given in percentage. 0% means the liquid will be bypassed, 100 % means the liquid is going through the cabinet cooling module and the drive power module. NOTE: The selection can only be accessed with APM Liquid Cooled (ATV·L0).
[Motor Current]	o C r	Current in the motor, from 0 to 2 In (In = rated drive current indicated in the Installation manual and on the drive nameplate)
[Motor Frequency]	o F r	Output frequency, from 0 to [Max Frequency] $E F r$ Factory Setting
[Sig. o/p frq.]	o F S	Signed output frequency, between –[Max Frequency] $E F r$ and +[Max Frequency] $E F r$
[PID error]	o P E	PID controller detected error between –5% and +5% of [Max PID feedback] $P , F 2$ – [Min PID feedback] $P , F 1$
[PID feedbk]	o P F	PID controller feedback between [Min PID feedback] $P , F 1$ and [Max PID feedback] $P , F 2$
[PID output]	o P ,	PID controller output between [Low speed] $L S P$ and [High speed] $H S P$
[Motor power]	o P r	Motor power, between 0 and 2.5 times [Nominal Motor Power] $n P r$
[PID ref.]	o P S	PID controller reference between [Min PID reference] $P , P 1$ and [Max PID reference] $P , P 2$
[Ramp out.]	o r P	From 0 to [Max Frequency] $E F r$
[sign ramp]	o r S	Signed ramp output, between –[Max Frequency] $E F r$ and +[Max Frequency] $E F r$
[Inlet Pressure Value]	P S I u	Inlet pressure value
[Outlet Pressure Value]	P S 2 u	Outlet pressure value
[Sign. torque]	S t 9	Signed motor torque, between –3 and +3 times the rated motor torque. The + sign corresponds to the motor mode and the – sign to the generator mode (braking).
[Drv thermal]	t H d	Drive thermal state, from 0 to 200% of the rated thermal state
[Mot thermal]	t H r	Motor thermal state, from 0 to 200% of the rated thermal state
[Motor torq.]	t r 9	Motor torque, from 0 to 3 times the rated motor torque
[Motor volt.]	u o P	Voltage applied to the motor, between 0 and [Nom Motor Voltage] $u n 5$

[AQ1 Type] $R o I t$

AQ1 type.

Select according to the requirements the type of output.

Setting	Code / Value	Description
[Voltage]	100	0-10 Vdc If necessary, adjust [AQ1 min Output] 100 L I and [AQ1 max Output] 100 H I.
[Current]	00	0-20 mA If necessary, adjust [AQ1 min output] 00 L I and [AQ1 max output] 00 H I. Factory setting

[AQ1 min output] 00 L I★

AQ1 min output value.

This parameter can be accessed if [AQ1 Type] 00 I E is set to [Current] 00.

Setting	Description
0.0...20.0 mA (step: 0.1 mA)	Setting range Factory setting: 0.0 mA

[AQ1 max output] 00 H I★

AQ1 max output value.

This parameter can be accessed if [AQ1 Type] 00 I E is set to [Current] 00.

Setting	Description
0.0...20.0 mA (step: 0.1 mA)	Setting range Factory setting: 20.0 mA

[AQ1 min Output] 100 L I★

AQ1 minimum output.

This parameter can be accessed if [AQ1 Type] 00 I E is set to [Voltage] 100.

Setting	Description
0.0...10.0 Vdc (step: 0.1 Vdc)	Setting range Factory setting: 0.0 Vdc

[AQ1 max Output] 100 H I★

AQ2 minimum output.

This parameter can be accessed if [AQ1 Type] 00 I E is set to [Voltage] 100.

Setting	Description
0.0...10.0 Vdc (step: 0.1 Vdc)	Setting range Factory setting: 10.0 Vdc

[Scaling AQ1 min] R 5 L 1

Scaling AQ1 min.

Scaling of the lower limit of the assigned parameter, as a % of the maximum possible variation.

Setting	Description
0.0...[Scaling AQ1 max] R 5 H 1 (step: 0.1 %)	Setting range Factory setting: 0.0%

[Scaling AQ1 max] R 5 H 1

Scaling AQ1 max.

Scaling of the upper limit of the assigned parameter, as a % of the maximum possible variation.

Setting	Description
[Scaling AQ1 min] R 5 L 1...100.0% (step: 0.1 %)	Setting range Factory setting: 100.0%

[AQ1 Filter] R 0 1 F

AQ1 filter.

Enable/disable the low pass-filter and configure its time constant.

Setting	Description
0.00...10.00 s (step: 0.01 s)	Setting range. If this parameter is set to 0.00 s, the filter is deactivated. Factory setting: 0.00 s

[Enable AQ1 fallback] R 0 F 1

Enable AQ1 fallback.

This parameter is forced to **[No]** n o if **[AQ1 Assignment]** R 0 1 is set to a value different from **[No]** n o.

If the output is controlled by fieldbus and has been enabled, transition to operating state Fault such as, but not limited to, communication interruption, will not disable the output if this parameter is set to **[No]** n o.

▲ WARNING**LOSS OF CONTROL**

- Verify that using this default setting does not result in unsafe conditions including communication interruption.
- Set this parameter to **[Yes]** Y E 5 to disable the output if an error is triggered.

Failure to follow these instructions can result in death, serious injury, or equipment damage.

Setting	Code / Value	Description
[No]	<i>no</i>	<p>Fallback feature disabled.</p> <p>When the output is assigned, the output value is defined according to its assignment, page 513.</p> <p>When the output is not assigned, the output value can be controlled via the internal parameter <i>R01r</i> (refer to the communication parameter addresses file). If an error is detected, the output remains unchanged.</p> <p>Factory setting</p>
[Yes]	<i>yes</i>	<p>Fallback feature enabled.</p> <p>The output value can be controlled via the internal parameter <i>R01r</i> (refer to the communication parameter addresses file). If an error is detected, the output is disabled.</p> <p>NOTE: If an error is detected, the process applied on the output (e.g. min, max, filter) remains applied.</p>

[AQ2 configuration] *R02* - Menu

Access

[Complete settings] → [Input/Output] → [AI/AQ] → [AQ1 configuration]

About This Menu

This menu is used to configure the analog output AQ2.

In this menu, the following parameters can be accessed:

- [AQ2 assignment] *R02*
- [AQ2 Type] *R02t*
- [AQ2 min output] *R02L*
- [AQ2 max output] *R02H*
- [AQ2 min Output] *u02L*
- [AQ2 max Output] *u02H*
- [Scaling AQ2 min] *R52L*
- [Scaling AQ2 max] *R52H*
- [AQ2 Filter] *R02F*
- [Enable AQ2 fallback] *R02F*

Refer to [AQ1 configuration] *R01* for more information about analog output configuration and the possible settings.

NOTE: In factory setting, the analog input AQ2 is set to [Motor Current] *02r* and is configured in [Current] *02r*.

[Virtual AI1] *A V I* - Menu to [Virtual AI3] *A V 3* - Menus

Access

[Complete settings] → [Input/Output] → [AI/AQ] → [Virtual AI1] to [Virtual AI3]

[AIV1 Assignment] *A V I A* to [AIV3 Assignment] *A V 3 A*

Virtual analog input function assignment. Read-only parameter.

Setting	Code / Value	Description
[No]	<i>n o</i>	Not assigned
[Ref Frequency 2 Summing]	<i>S A 2</i>	Reference frequency 2 summing
[PID Feedback]	<i>P , F</i>	PI controller feedback
[Subtract Ref Freq 2]	<i>d A 2</i>	Subtract reference frequency 2
[Ref Frequency 3 Summing]	<i>S A 3</i>	Reference frequency 3 summing
[Subtract Ref Freq 3]	<i>d A 3</i>	Subtract reference frequency 3
[Ref Frequency 2 multiplier]	<i>π A 2</i>	Reference frequency 2 multiplier
[Ref Frequency 3 multiplier]	<i>π A 3</i>	Reference frequency 3 multiplier
[InletPres Assign]	<i>P 5 I A</i>	Select the source of inlet pressure sensor
[OutletPres Assign]	<i>P 5 2 A</i>	Select the source of outlet pressure sensor
[Inst Flow Assign]	<i>F 5 I A</i>	Select the source of installation flow sensor
[Pump Flow Assign]	<i>F 5 2 A</i>	Select the source of pump flow sensor

[AIV1 Channel Assignment] *A , C I* to [AIV3 Channel Assignment] *A , C 3*

Channel assignment for virtual analog input AIV1, AIV2 and AIV3.

Setting	Code / Value	Description
[Not Configured]	<i>n o</i>	Not assigned Factory setting
[Ref. Freq-Modbus]	<i>π d b</i>	Reference frequency via Modbus
[Ref. Freq-CANopen]	<i>C A n</i>	Reference frequency via CANopen if a CANopen module has been inserted
[Ref. Freq-Com. Module]	<i>n E t</i>	Reference frequency via fieldbus module if a fieldbus module has been inserted
[Embedded Ethernet]	<i>E t H</i>	Embedded Ethernet

[AIV1 Type] AV 1E to [AIV3 Type] AV 3E

Configuration of virtual analog input AIV1, AIV2 and AIV3.

Setting	Code / Value	Description
[+/-8192]	1 n E G	-8192/+8192 Factory setting
[+/-100%]	P n E G	-100.00/+100.00 %

[Input/Output] - [Relay]

[Relay] \llcorner \llcorner \llcorner - Menu

Access

[Complete settings] \rightarrow [Input/Output] \rightarrow [Relay]

About This Menu

This menu is used to configure the relays of the drive:

- **[R1 configuration]** \llcorner \llcorner to **[R3 configuration]** \llcorner \llcorner : the relays R1 to R3 embedded to the drive.
- **[R4 configuration]** \llcorner \llcorner to **[R6 configuration]** \llcorner \llcorner : the relays R4 to R6 if the VW3A3204 relay output option module is inserted,
- **[R60 configuration]** \llcorner \llcorner to **[R66 configuration]** \llcorner \llcorner : the relays R60 to R66 inside Drive Systems enclosure for control and monitoring circuits. It can only be accessed on ATV●60, ATV●80 and ATV●L0 equipped with cabinet IO, and if **[Access Level]** \llcorner \llcorner is set to **[Expert]** \llcorner \llcorner .

On Graphic Display Terminal (VW3A1111), **[Relay]** \llcorner \llcorner - menu is the fourth tab displayed in the menu **[Input/Output]** \llcorner \llcorner - (the tab is named "Relay").

Use the touch wheel to scroll through the relays. Click OK to access the configuration of the relay.

On Graphic Display Terminal, if a relay is assigned then a check mark is displayed.

For a given relay (Rx), the configuration is composed by:

- **[Rx Assignment]** \llcorner \llcorner : the assignment of the relay Rx,
- **[Rx Delay time]** \llcorner \llcorner : the delay time of the relay Rx. It represents the delay before modifying the state of the relay when the assigned event becomes true,
- **[Rx Active at]** \llcorner \llcorner : the active level of the relay Rx. It defines the state 1 or 0 of the relay to the true state of the assigned event.
- **[Rx Holding Time]** \llcorner \llcorner : the holding time of the relay Rx. It represents the delay before modifying the state of the relay when the assigned event becomes false.
- **[Enable Rx fallback]** \llcorner \llcorner : parameter used to enable/disable the fallback mode triggered in case of communication interruption (if the relay is controlled by fieldbus communication).

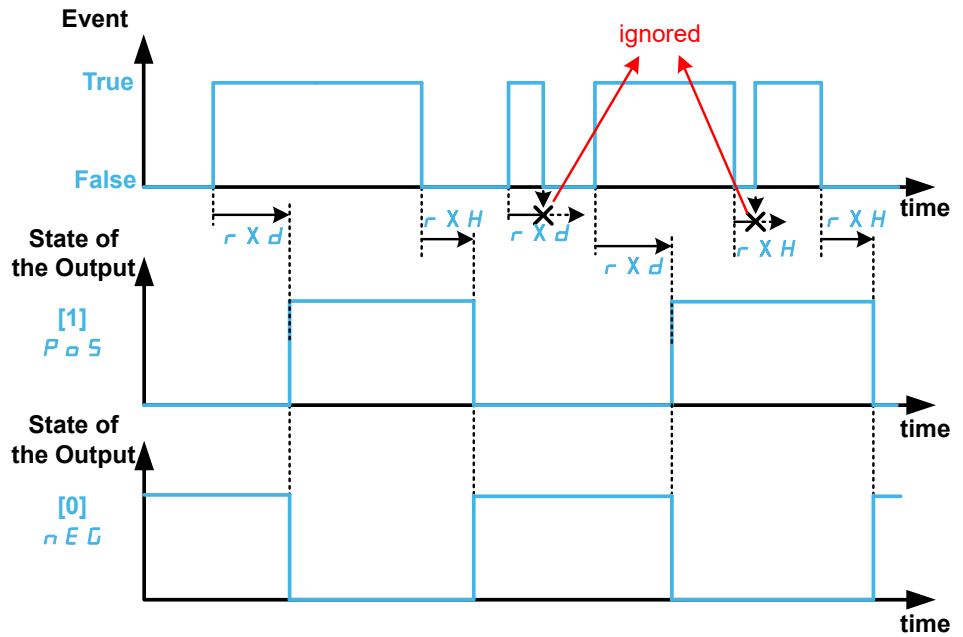

[Rx Assignment] r X

[R1 Assignment] r 1, [R2 Assignment] r 2, [R3 Assignment] r 3, [R4 Assignment] r 4, [R5 Assignment] r 5, [R6 Assignment] r 6, [R60 Assignment] r 60, [R61 Assignment] r 61, [R62 Assignment] r 62, [R63 Assignment] r 63, [R64 Assignment] r 64, [R65 Assignment] r 65, [R66 Assignment] r 66

Rx assignment.

It is used to assign the relay to an event or a function. The following table gives the possible settings:

If the output is set to [CDxx] CDxx or [Cxxx] Cxxx and has been enabled, transition to operating state Fault such as, but not limited to, communication interruption, will not disable the output.

⚠ WARNING

LOSS OF CONTROL

Only set the output to [CDxx] CDxx or [Cxxx] Cxxx after having verified that this setting cannot result in unsafe conditions including communication interruption.

Failure to follow these instructions can result in death, serious injury, or equipment damage.

Setting	Code / Value	Description
[No]	n o	Not assigned. NOTE: In this case, the output can be controlled via the internal parameter o L 1 r (refer to the communication parameter addresses file). By default, if an error (such as a communication interruption is detected), the output remains unchanged. Use the parameter [Enable Rx Fallback] r X F to disable the output in case of error detection. Factory setting ⁽¹⁾
[Warning Grp 1]... [Warning Grp 5]	R G 1...R G 5	Warning group 1 to Warning group 5.
[AI1 4-20 Loss Warning]...[AI5 4-20 Loss Warning]	R P 1...R P 5	4-20 mA loss warning on AI

Setting	Code / Value	Description
[Neg Torque]	R E S	Actual torque sign
[HMI Cmd]	b P P	Control via the Graphic Display Terminal is active. (only active with Local/Remote button)
[CB Stop Pulse]	C b d P	Circuit Breaker stop pulse ⁽²⁾ The output is automatically configured to this function by setting the parameter [CB Start Pulse Activated] C b E P.
[CB Start Pulse]	C b E P	Circuit Breaker start pulse ⁽²⁾ The output is automatically configured to this function by setting the parameter [CB Stop Pulse Activated] C b d P.
[CD00]...[CD15]	C d 0 0 .. C d 1 5 .	Bit x digital input ctrl word (e.g. virtual digital input CMD.0...CMD.15). The state of the output is modified accordingly with the bit of the control word. If an error is triggered (such as a communication error), the output remains unchanged. NOTE: CD00...CD10 are only accessible with [Control Mode] CHCF set to [I/O Profile] 1 0 .
[C100]...[C115]	C 1 0 0 ... C 1 1 5	Bit x Modbus ctrl word (e.g. Virtual digital input CMD1.00...CMD1.15 with integrated Modbus Serial). The state of the output is modified accordingly with the bit of the Modbus control word. If an error is triggered (such as a communication error), the output remains unchanged. NOTE: C100...C110 are only accessible with [Control Mode] CHCF set to [I/O Profile] 1 0 .
[C200]...[C215]	C 2 0 0 ... C 2 1 5	Bit x CANopen ctrl word (e.g. Virtual digital input CMD2.00...CMD2.15 with CANopen® fieldbus module). The state of the output is modified accordingly with the bit of the CANopen control word. If an error is triggered (such as a communication error), the output remains unchanged. NOTE: C200...C210 are only accessible with [Control Mode] CHCF set to [I/O Profile] 1 0 .
[C300]...[C315]	C 3 0 0 ... C 3 1 5	Bit x Com module ctrl word (e.g. Virtual digital input CMD3.00...CMD3.15 with fieldbus module). The state of the output is modified accordingly with the bit of the fieldbus module control word. If an error is triggered (such as a communication error), the output remains unchanged. NOTE: C300...C310 are only accessible with [Control Mode] CHCF set to [I/O Profile] 1 0 .
[C500]...[C515]	C 5 0 0 ... C 5 1 5	Bit x Ethernet ctrl word (e.g. Virtual digital input CMD3.00...CMD3.15 with Ethernet embedded). The state of the output is modified accordingly with the bit of the Ethernet embedded control word. If an error is triggered (such as a communication error), the output remains unchanged. NOTE: C500...C510 are only accessible with [Control Mode] CHCF set to [I/O Profile] 1 0 .
[set 1 active]...[set 2active]	C F P 1 ... C F P 3	Parameter set 1, 2 or 3 is active.
[Cnfg.0 act.]	C n F 0	Configuration 0 is active
[Current Thd Reached]	C E R	Motor current threshold ([High Current Thd] C E d) reached
[Low Current Reached]	C E R L	Current low threshold ([Low I Threshold] C E d L) reached
[DC Bus Charged]	d b L	DC bus charged
[External Error Warning]	E F R	External error warning
[Forced Run]	E r n	Emergency Run
[Mot Freq High Thd 2]	F 2 R	Second frequency threshold ([Freq. threshold 2] F 2 d) reached

Setting	Code / Value	Description
[Motor Freq Low Thd 2]	<i>F 2 R L</i>	Second frequency low threshold ([2 Freq. Threshold] <i>F 2 d L</i>) reached
[High Speed Reached]	<i>F L R</i>	High speed reached
[Operating State Fault]	<i>F L t</i>	Operating state fault
[Fallback speed]	<i>F r F</i>	Reaction on event / fallback speed
[Mot Freq High Thd]	<i>F t R</i>	Motor frequency threshold ([Motor Freq Thd] <i>F t d</i>) reached
[Mot Freq Low Thd]	<i>F t R L</i>	Frequency low threshold ([Low Freq. Threshold] <i>F t d L</i>) reached
[Idle State]	<i>i d L E</i>	Device in energy saving state
[Idle Rdy Or Run State]	<i>i d r r</i>	Device in energy saving or ready or running state.
[Idle Or Rdy State]	<i>i d r Y</i>	Device in energy saving or ready state.
[Internal Error 22]	<i>i n F n</i>	Internal error 22 (Embedded Ethernet)
[Jockey]	<i>J o k Y</i>	Jockey ⁽²⁾ The output is automatically configured to this function by setting the parameter [Jockey Selection] <i>J P</i> .
[Mains Contactor]	<i>L L C</i>	Mains contactor ⁽²⁾ The output is automatically configured to this function by setting the parameter [Mains Contactor] <i>L L C</i> .
[I present]	<i>n C P</i>	Motor current present
[Forward]	<i>n F r d</i>	Run forward
[M/P Device Warn]	<i>n P d R</i>	MultiPump Device Warning ⁽²⁾
[M/P Master Activated]	<i>n P n R</i>	Multipump Master Activated ⁽²⁾ The output is automatically configured to this function by setting the parameter [Master Active Assign] <i>n P n R</i> .
[Pump 1 Cmd]...[Pump 6 Cmd]	<i>n P o 1... n P o 6</i>	Pump command ⁽²⁾ The output is automatically configured to this function by setting the parameter [Pump X Cmd Assign] <i>n P o X</i> .
[Reverse]	<i>n r r S</i>	Run reverse
[Output cont]	<i>o C C</i>	Output contactor control ⁽²⁾ The output is automatically configured to this function by setting the parameter [Out. Contactor Assign] <i>o C C</i> .
[Process Overload Warning]	<i>o L R</i>	Overload warning
[PID Error Warning]	<i>P E E</i>	PID error warning
[PID Feedback Warning]	<i>P F R</i>	PID feedback warning
[PID High Fdbck Warning]	<i>P F R H</i>	PID feedback high threshold (PAH) reached
[PID Low Fdbck Warning]	<i>P F R L</i>	PID feedback low threshold (PAL) reached
[Regulation Warning]	<i>P , S H</i>	PID regulation unable to reach the set point
[Priming]	<i>P r , n</i>	Priming ⁽²⁾ The output is automatically configured to this function by setting the parameter [Priming Pump Assign] <i>P P o R</i> .
[Power Removal State]	<i>P r n</i>	Power removal state.

Setting	Code / Value	Description
		Without power supply, the information cannot be delivered. With this setting value, the power supply must be not external.
[Ready]	<i>r d Y</i>	Ready to start
[Speed Maintained]	<i>r L 5</i>	Reaction on event / maintain speed
[Ramp switching]	<i>r P 2</i>	Ramp switching state
[Ref Freq High Thd Reached]	<i>r E R H</i>	Frequency reference high threshold reached
[Ref Freq Low Thd Reached]	<i>r E R L</i>	Frequency reference low threshold reached
[Drive Running]	<i>r u n</i>	Drive running
[Rdy Or Run State]	<i>r Y r n</i>	Device in ready or running state.
[Ref Freq Reached]	<i>S r R</i>	Frequency reference reached
[Modbus Com Inter.]	<i>S L F I</i>	Modbus communication interruption warning
[Per Type of Stop]	<i>S E E</i>	Reaction on event / stop on STT without an error triggered after stop.
[Drv Therm Thd Reached]	<i>E R d</i>	Drive thermal threshold reached
[Drive Thermal Warning]	<i>E H R</i>	Drive thermal state warning
[IGBT Thermal Warning]	<i>E J R</i>	Thermal junction warning
[AI1 Th Warning]...[AI5 Th Warning]	<i>E P I R...</i> <i>E P 5 R</i>	Thermal warning on AI ⁽³⁾
[Temp Sens AI1 Warn]...[Temp Sens AI5 Warn]	<i>E S I R...</i> <i>E S 5 R</i>	Temperature sensor AI warning (open circuit) ⁽³⁾
[Motor Therm Thd Reached]	<i>E S R</i>	Motor thermal threshold ([Motor Therm Thd] <i>E E d</i>) reached
[High Torque Warning]	<i>E E H R</i>	High torque threshold
[Low Torque Warning]	<i>E E L R</i>	Low torque threshold
[Process Undld Warning]	<i>u L R</i>	Underload warning
[Preventive UnderV Active]	<i>u P R</i>	Undervoltage prevention warning
[Undervoltage Warning]	<i>u S R</i>	Undervoltage warning
[VxCtrl Running]	<i>V C C</i>	Vortex control is active
[VxCtrl Warning]	<i>V C R</i>	Vortex control warning
<p>(1): On relay R1, the factory setting is [Operating State Fault] <i>F L E</i>. On ATV●60 and ATV●80, the factory setting of R60 is [Cabinet Fan Command] <i>F C C</i>. R60 can only be assigned to No or FCC.</p> <p>(2): This setting cannot be accessed with R1.</p> <p>(3): Event on AI1 is not available on ATV600</p>		

[Rx Delay time] *r X d*

[R1 Delay time] *r 1 d*, [R2 Delay time] *r 2 d*, [R3 Delay time] *r 3 d*, [R4 Delay time] *r 4 d*, [R5 Delay time] *r 5 d*, [R6 Delay time] *r 6 d*, [R60 Delay time] *r 6 0 d*, [R61 Delay time] *r 6 1 d*, [R62 Delay time] *r 6 2 d*, [R63 Delay time] *r 6 3 d*, [R64 Delay time] *r 6 4 d*, [R65 Delay time] *r 6 5 d*, [R66 Delay time] *r 6 6 d*

Rx activation delay time.

It represents the delay before modifying the state of the relay when the assigned event becomes true.

If the corresponding relay is assigned to one of the following assignments, the delay is forced to 0 ms and it cannot be modified:

- **[Operating State “Fault”]** F L E ,
- **[Mains Contactor]** L L C ,
- **[Output Cont]** O C C ,
- **[Priming]** P r i Π ,
- **[Jockey]** J o K Y ,
- **[Pump 1 Cmd]** Π P o I...**[Pump 6 Cmd]** Π P o B ,
- **[M/P Master Activated]** Π P Π A .

Setting	Description
0...60,000 ms (step: 1 ms)	Setting range Factory setting: 0 ms

[Rx Active at] r X 5

[R1 Active at] r 1 5, **[R2 Active at]** r 2 5, **[R3 Active at]** r 3 5, **[R4 Active at]** r 4 5, **[R5 Active at]** r 5 5, **[R6 Active at]** r 6 5, **[R60 Active at]** r 6 0 5, **[R61 Active at]** r 6 1 5, **[R62 Active at]** r 6 2 5, **[R63 Active at]** r 6 3 5, **[R64 Active at]** r 6 4 5, **[R65 Active at]** r 6 5 5, **[R66 Active at]** r 6 6 5

Rx status (output active level).

It defines the state 1 or 0 of the relay to the true state of the assigned event.

If the relay R1...R6 is assigned to one of the following assignments, the delay is forced to **[1] Pos**:

- **[Operating State “Fault”]** F L E ,
- **[Mains Contactor]** L L C ,
- **[Output Cont]** O C C ,
- **[Priming]** P r i Π ,
- **[Jockey]** J o K Y ,
- **[Pump 1 Cmd]** Π P o I...**[Pump 6 Cmd]** Π P o B ,
- **[M/P Master Activated]** Π P Π A .

Setting	Code / Value	Description
1	P o 5	State 1 if the event is true. Factory setting
0	n E G	State 0 if the event is true.

[Rx Holding Time] r X H

[R1 Holding time] r 1 H, **[R2 Holding time]** r 2 H, **[R3 Holding time]** r 3 H, **[R4 Holding time]** r 4 H, **[R5 Holding time]** r 5 H, **[R6 Holding time]** r 6 H, **[R60 Holding time]** r 6 0 H, **[R61 Holding time]** r 6 1 H, **[R62 Holding time]** r 6 2 H, **[R63 Holding time]** r 6 3 H, **[R64 Holding time]** r 6 4 H, **[R65 Holding time]** r 6 5 H, **[R66 Holding time]** r 6 6 H

Rx holding delay time.

It represents the delay before modifying the state of the relay when the assigned event becomes false.

If the corresponding relay is assigned to one of the following assignments, the delay is forced to 0 ms and it cannot be modified:

- [Operating State “Fault”] *F L E*,
- [Mains Contactor] *L L C*,
- [Output Cont] *o C C*,
- [Priming] *P r i n*,
- [Jockey] *J o k y*,
- [Pump 1 Cmd] *Π P o 1*...[Pump 6 Cmd] *Π P o 6*,
- [M/P Master Activated] *Π P Π A*.

Setting	Description
0...9,999 ms (step: 1 ms)	Setting range Factory setting: 0 ms

[Enable Rx fallback] *r X F*

[Enable R1 fallback] *r 1 F*, [Enable R2 fallback] *r 2 F*, [Enable R3 fallback] *r 3 F*, [Enable R4 fallback] *r 4 F*, [Enable R5 fallback] *r 5 F*, [Enable R6 fallback] *r 6 F*

Enable relayX fallback.

This parameter is forced to [No] *n o* if [Rx Assignment] *r X* is set to a value different from [No] *n o*.

If the output is controlled by fieldbus and has been enabled, transition to operating state Fault such as, but not limited to, communication interruption, will not disable the output if this parameter is set to [No] *n o*.

⚠ WARNING
<p>LOSS OF CONTROL</p> <ul style="list-style-type: none"> • Verify that using this default setting does not result in unsafe conditions including communication interruption. • Set this parameter to [Yes] <i>y e s</i> to disable the output if an error is triggered. <p>Failure to follow these instructions can result in death, serious injury, or equipment damage.</p>

Setting	Code / Value	Description
[No]	<i>n o</i>	Fallback feature disabled. When the output is assigned, the state of the output is defined according to its assignment, page 521 When the corresponding output is not assigned, the state of the output can be controlled via a bit of <i>o L I r</i> (refer to the communication parameter addresses file). If an error is detected, the output remains unchanged. Factory setting
[Yes]	<i>y e s</i>	Fallback feature enabled. The state of the relay can be controlled via a bit of <i>o L I r</i> (refer to the communication parameter addresses file). If an error is detected, the output is disabled. NOTE: If an error is detected, the process applied on the output (e.g. delays, active level) remains applied.

[Input/Output] *I O -* Menu

Access

[Complete settings] → [Input/Output]

About This Menu

This parameter can be accessed with the Plain Text Remote Terminal or via the commissioning software.

[Ref Freq Template] *b S P*

Reference frequency template selection.

This parameter defines how the speed reference is taken into account, for analog inputs and pulse input. In the case of the PID controller, this is the PID output reference.

The limits are set by the [Low speed] *L S P* and [High speed] *H S P* parameters

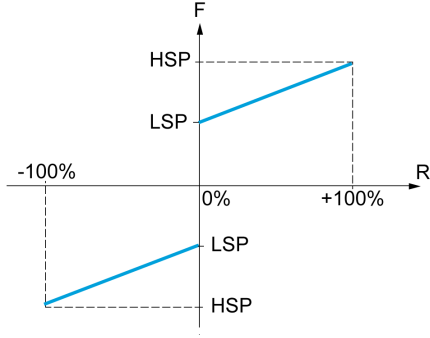
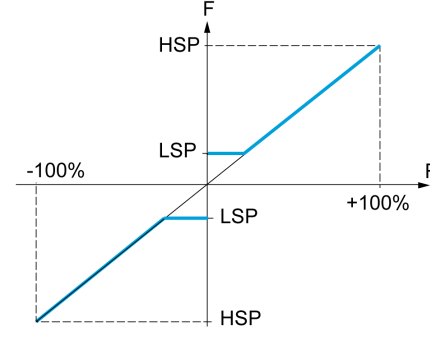
Setting 	Code / Value	Description
[Standard]	<i>b S d</i>	 <p>F Frequency</p> <p>R Reference At reference = 0, the frequency = [Low speed] <i>L S P</i></p> <p>Factory setting</p>
[Pedestal]	<i>b L S</i>	 <p>F Frequency</p> <p>R Reference At reference = 0 to [Low speed] <i>L S P</i>, the frequency = [Low speed] <i>L S P</i></p>

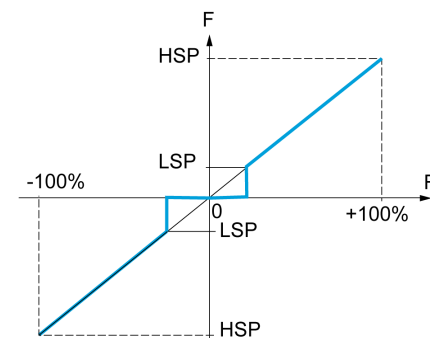
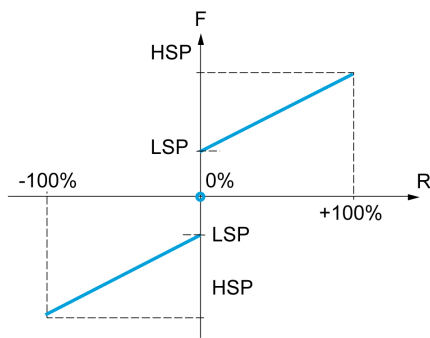
Setting ()	Code / Value	Description
[Deadband]	b n 5	 <p>F Frequency</p> <p>R Reference At reference = 0 to [Low speed] L S P the frequency = 0</p>
[Deadband at 0%]	b n 5 0	 <p>F Frequency</p> <p>R Reference This operation is the same as [Standard] b 5 d, except that in the following cases at zero reference, the frequency = 0: The signal is less than [Min nvalue], which is greater than 0 (example: 1 Vdc on a 2–10 Vdc input) The signal is greater than [Min nvalue], which is greater than [Max value] (example: 11 Vdc on a 10–0 Vdc input).</p> <p>If the input range is configured as “bidirectional”, operation remains identical to [Standard] b 5 d.</p>

[Error/Warning handling]

[Auto fault reset] *A E r* - Menu

Access

[Complete settings] → [Error/Warning handling] → [Auto fault reset]

[Auto Fault Reset] *A E r*

Automatic fault reset.

This function can be used to automatically perform individual or multiple Fault Resets. If the cause of the error that has triggered the transition to the operating state Fault disappears while this function is active, the drive resumes normal operation. While the Fault Reset attempts are performed automatically, the output signal **[Operating state Fault]** is not available. If the attempts to perform the Fault Reset are not successful, the drive remains in the operating state Fault and the output signal **[Operating state Fault]** becomes active.

▲ WARNING
UNANTICIPATED EQUIPMENT OPERATION
<ul style="list-style-type: none"> • Verify that activating this function does not result in unsafe conditions. • Verify that the fact that the output signal "Operating state Fault" is not available while this function is active does not result in unsafe conditions.
Failure to follow these instructions can result in death, serious injury, or equipment damage.

The drive fault relay remains activated if this function is active. The speed reference and the operating direction must be maintained.

It is recommended to use 2-wire control (**[2/3-wire control]** *E C C* is set to **[2 wire]** *2 C* and **[2-wire type]** *E C E* is set to **[Level]** *L E L*, refer to **[2/3-wire control]** *E C C*.

If the restart has not taken place once the configurable time **[Fault Reset Time]** *E A r* has elapsed, the procedure is aborted and the response to external error remains locked until it is turned off and then on again.

The detected error codes, which permit this function, are listed in the Diagnostics part of the manual.

Setting	Code / Value	Description
[No]	<i>n o</i>	Function inactive Factory setting
[Yes]	<i>y e s</i>	Automatic restart, after locking in error state, if the detected error has disappeared and the other operating conditions permit the restart. The restart is performed by a series of automatic attempts separated by increasingly longer waiting periods: 1 s, 5 s, 10 s, then 1 minute for the following attempts.

[Fault Reset Time] *E A r* ★

Maximum time for automatic restart function.

This parameter appears if **[Auto Fault Reset]** *A E r* is set to **[Yes]** *y e s*. It can be used to limit the number of consecutive restarts on a recurrent detected error.

Setting	Code / Value	Description
[5 minutes]	5	5 minutes Factory setting
[10 minutes]	10	10 minutes
[30 minutes]	30	30 minutes
[1 hour]	1h	1 hour
[2 hours]	2h	2 hours
[3 hours]	3h	3 hours
[Unlimited]	C E	Continuous

[Fault reset] r 5 E - Menu

Access

[Complete settings] → [Error/Warning handling] → [Fault reset]

[Fault Reset Assign] r 5 F

Fault reset input assignment.

Detected errors are cleared manually when the assigned input or bit changes to 1 if the cause of the detected error has been removed.

All errors cannot be cleared via a Fault Reset. Refer to the table in the part Diagnostics and Troubleshooting to have the full list, page 625.

The **STOP/RESET** key on the Graphic Display Terminal performs the same function.

Setting	Code / Value	Description
[Not Assigned]	n o	Not assigned
[DI1]...[DI6]	L , 1...L , 6	Digital input DI1...DI6 used at high level Factory setting: [DI4] L , 4
[DI11]...[DI16]	L , 11... L , 16	Digital input DI11...DI16 if VW3A3203 extended I/O module has been inserted.
[DI52 (High level)]...[DI59 (High level)]	d 5 2 H... d 5 9 H	Cabinet Digital input DI52...DI59 used at high level in case of ATV•60, ATV•80 equipped with cabinet IO.
[CD00]... [CD15]	C d 0 0... C d 1 5	Virtual digital input CMD.0...CMD.10 in [I/O profile] , o configuration.
[C101]... [C115]	C 1 0 1... C 1 1 5	Virtual digital input CMD1.01...CMD1.15 with integrated Modbus Serial in [I/O profile] , o configuration.
[C201]... [C215]	C 2 0 1... C 2 1 5	Virtual digital input CMD2.01...CMD2.10 with CANopen® fieldbus module in [I/O profile] , o configuration.
[C301]... [C315]	C 3 0 1... C 3 1 5	Virtual digital input CMD3.01...CMD3.15 with a fieldbus module in [I/O profile] , o configuration.
[C501]... [C515]	C 5 0 1... C 5 1 5	Virtual digital input CMD5.01...CMD5.150 with embedded Ethernet in [I/O profile] , o configuration.

[Product Restart] r P★

The Restart function performs a Fault Reset and then restarts the drive. During this Restart procedure, the drive goes through the same steps as if it had been switched off and on again. Depending on the wiring and the configuration of the drive, this may result in immediate and unanticipated operation.

▲ WARNING

UNANTICIPATED EQUIPMENT OPERATION

The Restart function performs a Fault Reset and restarts the drive.

- Verify that activating this function does not result in unsafe conditions.

Failure to follow these instructions can result in death, serious injury, or equipment damage.

Product restart.

This parameter can be accessed if **[Access Level] L R C** is set to **[Expert] E P r** mode.

This parameter can be used to reset all detected errors without having to disconnect the drive from the supply mains.

Setting	Code / Value	Description
[No]	n o	Function inactive Factory setting
[Yes]	y e s	Reinitialization. Press and hold down the OK key for 2 s. The parameter changes back to [No] n o automatically as soon as the operation is complete. The drive can only be reinitialized when locked.

[Prod Restart Assign] r P R ★

Product restart assignment.

The Restart function performs a Fault Reset and then restarts the drive. During this Restart procedure, the drive goes through the same steps as if it had been switched off and on again. Depending on the wiring and the configuration of the drive, this may result in immediate and unanticipated operation.

⚠ WARNING	
UNANTICIPATED EQUIPMENT OPERATION	
The Restart function performs a Fault Reset and restarts the drive.	
<ul style="list-style-type: none"> Verify that activating this function does not result in unsafe conditions. 	
Failure to follow these instructions can result in death, serious injury, or equipment damage.	

This parameter can be accessed if **[Access Level] L R C** is set to **[Expert] E P r** mode.

Setting	Code / Value	Description
[Not Assigned]	n o	Not assigned Factory setting
[DI1]...[DI6]	L , I ... L , I 6	Digital input DI1...DI6 used at high level
[DI11 (High level)]...[DI16 (high level)]	L , I I ... L , I 6	Digital input DI11...DI16 if VW3A3203 extended I/O module has been inserted.
[DI52 (High level)]...[DI59 (high level)]	d 5 2 H ... d 5 9 H	Cabinet Digital input DI52...DI59 used at high level in case of ATV*60, ATV*80 equipped with cabinet IO.

[Extended Fault Reset] H r F C ★

Hardware detected error configuration.

When **H r F C** is set to **y e s**, it allows you to reset hardware type error with the Fault Reset function (see above **[Fault Reset Assign] r 5 F**).

All hardware type errors cannot be cleared via a this feature. Refer to the table in the part Diagnostics and Troubleshooting to have the full list , page 625.

This feature allows to clear these hardware type errors without disconnection the drive from the power supply.

NOTICE
<p>INOPERATIVE DRIVE</p> <ul style="list-style-type: none"> • Verify that enabling this parameter does not result in equipment damage. • Before resetting the detected error, identify and correct the cause of the error. <p>Failure to follow these instructions can result in equipment damage.</p>

This parameter can be accessed if **[Access Level] L R C** is set to **[Expert] E P r** mode.

Setting	Code / Value	Description
[No]	n o	Not enable Factory setting⁽¹⁾
[Yes]	y e s	Enable, some hardware type errors can be reset via Fault Reset function.
<small>(1): The factory setting value switches to [Yes] y e s for ATV●30●●●●●F, ATV●50●●●●●F, ATV●60, ATV●80, ATV●A0, ATV●B0 and ATV●L0.</small>		

[Catch on the fly] F L r - Menu

Access

[Complete settings] → [Error/Warning handling] → [Catch on the fly]

[Catch On Fly] F L r

Catch on the fly.

Used to enable a smooth restart if the run command is maintained after the following events:

- Loss of line supply or disconnection.
- Clearing clearance of current detected error or automatic restart.
- Freewheel stop.

The speed given by the drive resumes from the estimated or measured speed of the motor at the time of the restart, then follows the ramp to the reference speed.

This function requires 2-wire level control.

When the function is operational, it activates at each run command, resulting in a slight delay of the current (0.5 s max).

[Catch On Fly] F L r is forced to [No] n o if [Auto DC Injection] A d C is set to [Continuous] C E .

Setting	Code / Value	Description
[Not Configured]	n o	Function inactive. Factory setting
[Yes On Freewheel]	Y E S	Function active only after freewheel stop.
[Yes Always]	A L L	Function active after all stop type

NOTE: For synchronous reluctance motor, it is recommended to set [Angle Setting Type] A S E to [Rotational Current Injection] r C i .

[Catch on Fly Sensitivity] V C b ★

Catch on fly sensitivity.

This parameter can only be accessed if [Access Level] L A C is set to [Expert] E P r .

Setting the value of parameter [Catch on Fly Sensitivity] V C b too low may cause a wrong estimation of the speed of the motor.

⚠ WARNING

LOSS OF CONTROL

- Only reduce gradually the value of parameter [Catch on Fly Sensitivity] V C b .
- During commissioning, verify that the drive and the system operate as intended by performing tests and simulations in a controlled environment under controlled conditions

Failure to follow these instructions can result in death, serious injury, or equipment damage.

Setting	Description
0.10...100.00 V	Setting range Factory setting: 0.20 V

[Catch On Fly Mode] C o F n

Velocity detection method for the Catch on Fly function.

[Catch On Fly Mode] C o F n is forced to **[Measured] Hw C o F** for synchronous motors.

Setting	Code / Value	Description
[Measured]	<i>Hw C o F</i>	Hardware catch on the fly The motor voltage signal should be greater than [Catch on Fly Sensitivity] V C b to be able to estimate the speed. Factory setting
[Computed]	<i>Sw C o F</i>	Software catch on the fly A signal is injected to estimate the speed and the position of the rotor. [Computed] Sw C o F method is not effective for a motor velocity range exceeding -HSP or +HSP.

[Error detect disabling] I n H - Menu

Access

[Complete settings] → [Error/Warning handling] → [Error detect disabling]

[Disable Error Detect] I n H★

Disable error detection.

In rare cases, the monitoring functions of the device may be unwanted because they impede the purpose of the application. A typical example is a smoke extractor fan operating as a part of a fire protection system. If a fire occurs, the smoke extractor fan should operate as long as possible, even if, for example, the permissible ambient temperature of the device is exceeded. In such applications, damage to or destruction of the device may be acceptable as collateral damage, for example, to keep other damage from occurring whose hazard potential is assessed to be more severe.

A parameter is provided to disable certain monitoring functions in such applications so that automatic error detection and automatic error responses of the device are no longer active. You must implement alternative monitoring functions for disabled monitoring functions that allow operators and/or master control systems to adequately respond to conditions which correspond to detected errors. For example, if overtemperature monitoring of the device is disabled, the device of a smoke extractor fan may itself cause a fire if errors go undetected. An overtemperature condition can be, for example, signaled in a control room without the device being stopped immediately and automatically by its internal monitoring functions.

⚠ DANGER

ERROR DETECTION FUNCTIONS DISABLED, NO ERROR DETECTION

- Only use this parameter after a thorough risk assessment in compliance with all regulations and standards that apply to the device and to the application.
- Implement alternative monitoring functions for disabled monitoring functions that do not trigger automatic error responses of the device, but allow for adequate, equivalent responses by other means in compliance with all applicable regulations and standards as well as the risk assessment.
- Commission and test the system with the monitoring functions enabled.
- During commissioning, verify that the device and the system operate as intended by performing tests and simulations in a controlled environment under controlled conditions.

Failure to follow these instructions will result in death or serious injury.

This parameter can be accessed if [Access Level] L A C is set to [Expert] E P r .

If the assigned input or bit state is:

- 0: error detection is enabled.
- 1: error detection is disabled.

Current errors are cleared on a rising edge from 0 to 1 of the assigned input or bit.

Detection of following errors can be disabled: ACF1, ACF2, CFA, CFB, CFC, CHF, CNF, COF, COPF, DRYF, EPF1, EPF2, ETHF, FCF1, FCF2, FDR1, FDR2, FFDF, FWER, HFPF, IFA, IFB, IFC, IFD, INFB, INFV, IPPF, JAMF, LCHF, LCLF, LFF1, LFF2, LFF3, LFF4, LFF5, LKON, MDLF, MFF, MOF, MPDF, MPLF, OBF, OHF, OLC, OLF, OPF1, OPF2, OPHF, OPLF, OSF, P24C, PCPF, PFMF, PGLF, PHF, PLFF, SLF1, SLF2, SLF3, SOF, STF, T2CF, T3CF, T4CF, T5CF, TFA, TFB, TFC, TFD, TH2F, TH3F, TH4F, TH5F, TJF, TJF2, TNF, ULF, URF, USF.

Setting	Code / Value	Description
[Not Assigned]	n o	Not assigned Factory setting
[DI1]...[DI6]	L , 1...L , 6	Digital input DI1...DI6
[DI11]...[DI16]	L , 11... L , 16	Digital input DI11...DI16 if VW3A3203 I/O extension module has been inserted
[CD00]... [CD10]	C d 0 0... C d 1 0	Virtual digital input CMD.0...CMD.10 in [I/O profile] , o configuration
[CD11]... [CD15]	C d 1 1... C d 1 5	Virtual digital input CMD.11...CMD.15 regardless of configuration
[C101]... [C110]	C 1 0 1... C 1 1 0	Virtual digital input CMD1.01...CMD1.10 with integrated Modbus Serial in [I/O profile] , o configuration
[C111]... [C115]	C 1 1 1... C 1 1 5	Virtual digital input CMD1.11...CMD1.15 with integrated Modbus Serial regardless of configuration
[C201]... [C210]	C 2 0 1... C 2 1 0	Virtual digital input CMD2.01...CMD2.10 with CANopen® fieldbus module in [I/O profile] , o configuration
[C211]... [C215]	C 2 1 1... C 2 1 5	Virtual digital input CMD2.11...CMD2.15 with CANopen® fieldbus module regardless of configuration
[C301]... [C310]	C 3 0 1... C 3 1 0	Virtual digital input CMD3.01...CMD3.10 with a fieldbus module in [I/O profile] , o configuration
[C311]... [C315]	C 3 1 1... C 3 1 5	Virtual digital input CMD3.11...CMD3.15 with a fieldbus module regardless of configuration
[C501]... [C510]	C 5 0 1... C 5 1 0	Virtual digital input CMD5.01...CMD5.10 with integrated Ethernet in [I/O profile] , o configuration
[C511]... [C515]	C 5 1 1... C 5 1 5	Virtual digital input CMD5.11...CMD5.15 with integrated Ethernet regardless of configuration

[Forced Run] , n H 5 ★

Disable error detection on run order.

In rare cases, the monitoring functions of the drive may be unwanted because they impede the purpose of the application. In addition, the Run command is to be forced via a digital input. A typical example is a smoke extractor fan operating as a part of a fire protection system. If a fire occurs, the smoke extractor fan should operate as long as possible, even if, for example, the permissible ambient temperature of the drive is exceeded or the wiring is destroyed. In such applications, damage to or destruction of the device may be acceptable as collateral damage, for example, to keep other damage from occurring whose hazard potential is assessed to be more severe.

A parameter is provided to disable certain monitoring functions in such applications so that automatic error detection and automatic error responses of the device are no longer active. You must implement alternative monitoring functions for disabled monitoring functions that allow operators and/or master control systems to adequately respond to conditions which correspond to detected errors. For example, if overtemperature monitoring of the drive is disabled, the drive of a smoke extractor fan may itself cause a fire if errors go undetected. An overtemperature condition can be, for example, signaled in a control room without the drive being stopped immediately and automatically by its internal monitoring functions. In addition, it may not be possible to stop the drive.

⚠ DANGER

MONITORING FUNCTIONS DISABLED, NO ERROR DETECTION, UNANTICIPATED EQUIPMENT OPERATION

- Only use this parameter after a thorough risk assessment in compliance with all regulations and standards that apply to the device and to the application.
- Implement alternative monitoring functions for disabled monitoring functions that do not trigger automatic error responses of the drive, but allow for adequate, equivalent responses by other means in compliance with all applicable regulations and standards as well as the risk assessment.
- Verify that permanently forcing the Run command via a digital input does not result in unsafe conditions.
- Commission and test the system with the monitoring functions enabled.
- During commissioning, verify that the drive and the system operate as intended by performing tests and simulations in a controlled environment under controlled conditions.

Failure to follow these instructions will result in death or serious injury.

Setting	Code / Value	Description
[Disabled]	n o	Function inactive Factory setting
[Forced Run FW]	F r d	Forced forward run.
[Forced Run RV]	r r 5	Forced reverse run.

[Forced Run Ref] 1 n H r ★

Forced Run Reference Frequency.

This parameter can be accessed if [Forced Run] 1 n H 5 is not set to [Disabled] n o.

This parameter causes the reference to be forced to the configured value when the input or bit for error detection disabled is at 1, with priority over all other references. Value 0 = function inactive. The factory setting changes to 60 Hz if [Motor Standard] b F r = [60 Hz NEMA] 6 0.

Setting	Description
0...[Max Frequency] 1 F r	Factory setting: 50 Hz

[External error] E 5 F - Menu

Access

[Complete settings] → [Error/Warning handling] → [External error]

[Ext Error Assign] E 5 F

External error assignment.

If the assigned bit state is:

- 0: there is no external error.
- 1: there is an external error

Setting	Code / Value	Description
[Not Assigned]	n o	Not assigned Factory setting
[DI1]...[DI6]	L , 1...L , 6	Digital input DI1...DI6
[DI11]...[DI16]	L , 11... L , 16	Digital input DI11...DI16 if VW3A3203 I/O extension module has been inserted
[CD00]... [CD10]	C d 0 0... C d 1 0	Virtual digital input CMD.0...CMD.10 in [I/O profile] , o configuration
[CD11]... [CD15]	C d 1 1... C d 1 5	Virtual digital input CMD.11...CMD.15 regardless of configuration
[C101]... [C110]	C 1 0 1... C 1 1 0	Virtual digital input CMD1.01...CMD1.10 with integrated Modbus Serial in [I/O profile] , o configuration
[C111]... [C115]	C 1 1 1... C 1 1 5	Virtual digital input CMD1.11...CMD1.15 with integrated Modbus Serial regardless of configuration
[C201]... [C210]	C 2 0 1... C 2 1 0	Virtual digital input CMD2.01...CMD2.10 with CANopen® fieldbus module in [I/O profile] , o configuration
[C211]... [C215]	C 2 1 1... C 2 1 5	Virtual digital input CMD2.11...CMD2.15 with CANopen® fieldbus module regardless of configuration
[C301]... [C310]	C 3 0 1... C 3 1 0	Virtual digital input CMD3.01...CMD3.10 with a fieldbus module in [I/O profile] , o configuration
[C311]... [C315]	C 3 1 1... C 3 1 5	Virtual digital input CMD3.11...CMD3.15 with a fieldbus module regardless of configuration
[C501]... [C510]	C 5 0 1... C 5 1 0	Virtual digital input CMD5.01...CMD5.10 with integrated Ethernet Modbus TCP in [I/O profile] , o configuration
[C511]... [C515]	C 5 1 1... C 5 1 5	Virtual digital input CMD5.11...CMD5.15 with integrated Ethernet Modbus TCP regardless of configuration
[DI1 (Low level)]...[DI6 (Low level)]	L 1 L ...L 6 L	Digital input DI1...DI6 used at low level
[DI52 (High level)]... [DI59 (High level)]	d 5 2 H... d 5 9 H	Cabinet high level digital inputs NOTE: This selection can be accessed on ATV660 and ATV680 equipped with Cabinet IO.
[DI52 (Low level)]... [DI59 (Low level)]	d 5 2 L... d 5 9 L	Cabinet low level digital inputs NOTE: This selection can be accessed on ATV660 and ATV680 equipped with Cabinet IO.

[Ext Error Resp] E 5 P L

Drive response to external error.

Type of stop in the event of an external detected error.

Setting	Code / Value	Description
[Ignore]	n o	External detected error ignored
[Freewheel Stop]	4 E 5	Freewheel stop Factory setting
[Per STT]	5 E 5	Stop according to configuration of [Type of stop] 5 E 5 , page 439, without tripping. In this case, the detected error relay does not open and the drive is ready to restart as soon as the detected error disappears, according to the restart conditions of the active command channel (for example, according to [2/3-wire control] 5 5 5 and [2-wire type] 5 5 5 , page 241 if control is via the terminals). Configuring a warning for this detected error is recommended (assigned to a digital output, for example) in order to indicate the cause of the stop.
[Fallback speed]	L F F	Change to fallback speed, maintained as long as the detected error persists and the run command has not been removed ⁽¹⁾
[Speed maintained]	r L 5	The drive maintains the speed being applied when the detected error occurred, as long as the detected error is active and the run command has not been removed ⁽¹⁾
[Ramp stop]	r P P	Stop on ramp
[Fast stop]	F 5 5	Fast stop
[DC Injection]	d C i	DC injection stop. This type of stop cannot be used with some other functions.
(1) Because, in this case, the detected error does not trigger a stop, it is advisable to assign a relay or digital output to its indication.		

[External error] — [Monitoring circuit A] C n C A - to [Monitoring circuit D] C n C d - Menus

Access

[Complete settings] → [Error/Warning handling] → [External error] → [Monitoring circuit A] to [Monitoring circuit D]

About These Menus

These menus are used to assign external “Monitoring Circuits” events to drive inputs in order to trigger an error or a warning.

The Monitoring Circuits, wired to these assigned inputs (using [MonitorCircuit X Assign] , F A X), give the possibility to manage 2 levels of monitoring according to [MonitorCircuit ErrorResp] , F r X configuration:

- A Warning level: the drive triggers a warning [MonitorCircuit Warn] , w X without stopping the application. Because, in this case, the detected error does not trigger a stop, it is recommended to assign a relay or logic output to its indication.
- An Error level: the drive triggers an error [MonitorCircuit Error] , F X and stops the application.

Additionally, it is possible to define:

- [MonitorCircuit X Monitor] , F n X: The required drive state conditions to have the monitoring active.
- [MonitorCircuit X Delay] , F d X: The delay before triggering the error or the warning.

[MonitorCircuit X Assign] , F A X

[MonitorCircuit A Assign] , F A A, [MonitorCircuit B Assign] , F A B, [MonitorCircuit C Assign] , F A C, [MonitorCircuit D Assign] , F A d

Monitoring circuit X assignment (with X = A, B, C or D)

This parameter is used to assign an digital input or a bit to the Monitoring Circuit X.

Monitoring event active when the assigned digital input (high level) or bit switches to 1. With low level, it is when the digital input switches to 0.

Setting	Code / Value	Description
[Not Assigned]	n o	Not assigned Factory setting
[DI1]...[DI6]	L , 1...L , 6	Digital input DI1...DI6
[DI11]...[DI16]	L , 11... L , 16	Digital input DI11...DI16 if VW3A3203 Extended I/O module has been inserted
[DI1 (Low level)]...[DI6 (Low level)]	L 1 L ...L 6 L	Digital input DI1...DI6 used at low level
[DI11 (Low level)]...[DI16 (Low level)]	L 11 L ... L 16 L	Digital input DI11...DI16 used at low level if VW3A3203 Extended I/O module has been inserted
[CD00]... [CD15]	C d 0 0... C d 1 5	Bit x digital input ctrl word (e.g. virtual digital input CMD.00...CMD.15). NOTE: CD00...CD10 are only accessible with [Control Mode] C H C F set to [I/O Profile] , o .
[C101]... [C115]	C 1 0 1... C 1 1 5	Bit x Modbus ctrl word (e.g. Virtual digital input CMD1.01...CMD1.15 with integrated Modbus Serial)

Setting	Code / Value	Description
		NOTE: C101...C110 are only accessible with [Control Mode] C H C F set to [I/O Profile] , o .
[C201]... [C215]	C 2 0 1 ... C 2 1 5	Bit x CANopen ctrl word (e.g. Virtual digital input CMD2.01...CMD2.15 with CANopen® fieldbus module) NOTE: C201...C210 are only accessible with [Control Mode] C H C F set to [I/O Profile] , o .
[C301]... [C315]	C 3 0 1 ... C 3 1 5	Bit x Com module ctrl word (e.g. Virtual digital input CMD3.01...CMD3.15 with fieldbus module) NOTE: C301...C310 are only accessible with [Control Mode] C H C F set to [I/O Profile] , o .
[C501]... [C515]	C 5 0 1 ... C 5 1 5	Bit x Ethernet ctrl word (e.g. Virtual digital input CMD3.01...CMD3.15 with Ethernet embedded) NOTE: C501...C510 are only accessible with [Control Mode] C H C F set to [I/O Profile] , o .
[DI52 (High level)]... [DI59 (High level)]	d 5 2 h ... d 5 9 h	Cabinet high level digital inputs NOTE: This selection can be accessed on ATV•60, ATV•80 equipped with Cabinet IO.
[DI52 (Low level)]... [DI59 (Low level)]	d 5 2 L ... d 5 9 L	Cabinet low level assignment digital inputs NOTE: This selection can be accessed on ATV•60, ATV•80 equipped with Cabinet IO.

[MonitorCircuit X Monitor] , F M X ★

[MonitorCircuit A Monitor] , F M A , **[MonitorCircuit B Monitor]** , F M B ,
[MonitorCircuit C Monitor] , F M C , **[MonitorCircuit D Monitor]** , F M D

Monitoring circuit X error monitoring type (with X = A, B, C or D)

This parameter defines the required drive state conditions to have the monitoring of “monitoring circuit x” active.

This parameter can be accessed if Monitoring circuit X is assigned (i.e. **[MonitorCircuit X Assign]** , F A X is set to a value different from **[No]** n o).

Setting	Code / Value	Description
[Always Active]	A L L	Always active: monitoring is active irrespective of the drive state. Factory setting
[Ready & Run State]	r r Y	Ready and Run state: monitoring is active only if the drive is in RDY or RUN.
[Run State]	r u n	Run state: monitoring is active only if the drive is in RUN.

[MonitorCircuit X Delay] , F d X ★

[MonitorCircuit A Delay] , F d A , **[MonitorCircuit B Delay]** , F d B ,
[MonitorCircuit C Delay] , F d C , **[MonitorCircuit D Delay]** , F d D

Monitoring circuit X delay (with X = A, B, C or D)

This parameter defines a delay before triggering the error or warning. This delay starts when the drive meets the condition defined by **[MonitorCircuit X Monitor]** , F M X and the input assigned to **[MonitorCircuit X Assign]** , F A X switches in the correct state.

This parameter can be accessed if Monitoring circuit X is assigned (i.e. **[MonitorCircuit X Assign]** , F A X is set to a value different from **[No]** n o).

Setting	Description
0...300 s (step: 1 s)	Setting range Factory setting: 0 s

[MonitorCircuit X ErrorResp] , F r X ★

[MonitorCircuit A ErrorResp] , F r A, [MonitorCircuit B ErrorResp] , F r b,
[MonitorCircuit C ErrorResp] , F r C, [MonitorCircuit D ErrorResp] , F r d

Response to monitoring circuit X error (with X = A, B, C or D)

This parameter defines the drive response to the “monitoring circuit X” related event that occurs at the end of the delay [MonitorCircuit X Delay] , F d X .

Concerned warnings: [MonitorCircuit X Warn] , W X

Concerned errors: [MonitorCircuit X Error] , F X

This parameter can be accessed if Monitoring circuit X is assigned (i.e. [MonitorCircuit X Assign] , F A X is set to a value different from [No] n o).

Setting	Code / Value	Description
[Ignore]	n o	Detected error ignored: A warning is triggered. ⁽¹⁾
[Freewheel Stop]	Y E S	Freewheel stop: the drive stops in freewheel and an error is triggered. Factory setting
[Per STT]	S t t	Stop according to [Type of stop] S t t parameter but without error or warning triggered after stop.
[Fallback Speed]	L F F	Change to fallback speed (defined with [Fallback Speed] L F F), maintained as long as the detected event persists and the run command has not been removed ⁽¹⁾
[Spd maintained]	r L S	Speed maintained as long as the detected event persists and the run command has not been removed ⁽¹⁾
[Ramp stop]	r n P	Stop on ramp: the drive stops on ramp and an error is triggered.
[Fast stop]	F S t	Fast stop: the drive stops on fast stop and an error is triggered.
[DC injection]	d C ,	DC injection: the drive stops on DC injection and an error is triggered.
⁽¹⁾ : Because, in this case, the detected error does not trigger a stop, it is recommended to assign a relay or logic output to its indication.		

[Output phase loss] $\square P L$ - Menu

Access

[Complete settings] → [Error/Warning handling] → [Output phase loss]

[OutPhaseLoss Assign] $\square P L$

Output phase loss assignment.

⚡ ⚠ DANGER

HAZARD OF ELECTRIC SHOCK, EXPLOSION OR ARC FLASH

If output phase monitoring is disabled, phase loss and, by implication, accidental disconnection of cables, are not detected.

- Verify that the setting of this parameter does not result in unsafe conditions.

Failure to follow these instructions will result in death or serious injury.

NOTE: [OutPhaseLoss Assign] $\square P L$ is forced to [Function Inactive] $n \square$ when [Motor control type] C E E is set to [SYN_U VC] $\square Y n u$ or [Reluctance Motor] $\square r v c$.

Setting	Code / Value	Description
[Function Inactive]	$n \square$	Function inactive
[OPF Error Triggered]	$\square Y E S$	Tripping on [OutPhaseLoss Assign] $\square P L$ with freewheel stop Factory setting
[No Error Triggered]	$\square R C$	No detected error triggered, but management of the output voltage in order to avoid an overcurrent when the link with the motor is re-established and catch on the fly performed (even if this function has not been configured). The drive switches to [Output cut] $\square \square c$ state after [OutPhL Time] $\square d t$ time. Catch on fly is possible as soon as the drive is in stand by output cut [Output cut] $\square \square c$ state.

[OutPhaseLoss Delay] $\square d t$

Output (motor) phase loss detection time.

Time delay for taking the [OutPhaseLoss Assign] $\square P L$ detected error into account.

Setting 	Description
0.5...10 s	Setting range Factory setting: 0.5 s

[Input phase loss] , P L - Menu

Access

[Complete settings] → [Error/Warning handling] → [Input phase loss]

[InPhaseLoss Assign] , P L ★

Loss of input phase error response.

If one supply mains phase is missing and if this leads to performance decrease, an **[Input phase loss] P H F** error is triggered.

If 2 or 3 supply mains phases are missing, the drive operate until an **[Supply Mains UnderV] μ 5 F** error is triggered.

This parameter can only be accessed on ATV630 and ATV650.

This parameter is forced to **[Freewheel] 5 E 5** on drives different from ATV630 and ATV650.

Setting	Code / Value	Description
[Ignore]	n o	The input phase loss monitoring function is disabled to be used when the drive is supplied via a single-phase supply or by the DC bus
[Freewheel]	5 E 5	The drive stops in freewheel in case of a supply mains phase loss has been detected Factory setting

[4-20mA loss] L F L - Menu

Access

[Complete settings] → [Error/Warning handling] → [4-20mA loss]

[AI1 4-20mA Loss] L F L 1

Response to 4-20mA loss on AI1.

Drive behavior on AI1 4-20 event.

Setting	Code / Value	Description
[Ignore]	n o	Detected error ignored. This is the only possible configuration if [AI1 min. value] L r L 1 is not greater than 3 mA Factory setting
[Freewheel]	y e s	Freewheel stop
[Per STT]	s t t	Stop according to configuration of [Type of stop] s t t, without tripping. In this case, the error relay does not open and the drive is ready to restart as soon as the detected error disappears, according to the restart conditions of the active command channel (for example, according to [2/3-wire control] t c t and [2-wire type] t c t if control is via the terminals). Configuring a warning for this detected error is recommended (assigned to a digital output, for example) in order to indicate the cause of the stop
[fallback spd]	L F F	Change to fallback speed, maintained as long as the detected error persists and the run command has not been removed ⁽¹⁾
[Spd maint.]	r L S	The drive maintains the speed being applied when the detected error occurred, as long as the detected error is active and the run command has not been removed ⁽¹⁾ . If the run order is removed and a new run order is given while the error is still active, the speed setpoint is defined by [Spd Maint Behavior] r L S: <ul style="list-style-type: none"> • [Spd Maint Behavior] RLS=0, then the speed setpoint is 0 Hz • [Spd Maint Behavior] RLS=LSp, then the speed setpoint is the value of the [Low Speed] L 5 P parameter.
[Ramp stop]	r n p	Stop on ramp
[Fast stop]	F S t	Fast stop
[DC injection]	d c i	DC injection stop. This type of stop cannot be used with some other functions

(1) Because, in this case, the detected error does not trigger a stop, it is advisable to assign a relay or digital output to its indication.

[AI2 4-20mA loss] L F L 2

Response to 4-20mA loss on AI2.

Drive behavior on AI2 4-20 event.

Identical to [AI1 4-20mA Loss] L F L 1

[AI3 4-20mA loss] L F L 3

Response to 4-20mA loss on AI3.

Drive behavior on AI3 4-20 event.

Identical to [AI1 4-20mA Loss] L F L 1

[AI4 4-20mA loss] L F L 4★

Response to 4-20mA loss on AI4.

Drive behavior on AI4 4-20 event.

Identical to **[AI1 4-20mA Loss] L F L 1**

This parameter can be accessed if VW3A3203 I/O extension module has been inserted.

[AI5 4-20mA loss] L F L 5★

Response to 4-20mA loss on AI5.

Drive behavior on AI5 4-20 event.

Identical to **[AI1 4-20mA Loss] L F L 1**

This parameter can be accessed if VW3A3203 I/O extension module has been inserted.

[Fallback Speed] L F F ★

Fall back speed.

Setting	Description
0.0...500.0 Hz	Setting range Factory setting: 0.0 Hz

[AI Loss Inhibition] n L F

Drive behavior on AI 4-20 event inhibition.

Setting	Code / Value	Description
[No]	n o	The drive behaves according to the selection of the AI 4-20 mA Loss Factory setting
[Yes]	y e 5	When the lost AI is assigned to [Ref Freq 1 Config] F r 1 , [Ref.1B channel] F r 1 b or [Ref Freq 2 Config] F r 2 , the drive ignores the response to the 4-20 mA loss event when set to [Speed maintained] r L 5 or [fallback Speed] L F F , and prioritizes the channels switching by applying the reference frequency given through the reference channels [Ref Freq 1 Config] F r 1 or [Ref.1B channel] F r 1 b or [Ref Freq 2 Config] F r 2 or [Forced Local Freq] F L o C (according to [Freq Switch Assign] r F C , [Ref 1B switching] r C b and [Forced Local Assign] F L o parameters). Note: When the lost AI is assigned to [Forced Local Freq] F L o C , the reference channel switching is possible only after deactivating [Forced Local Assign] F L o .

[Fallback speed] L F F - Menu

Access

[Complete settings] → [Error/Warning handling] → [Fallback speed]

[Fallback Speed] L F F

Fall back speed.

Setting	Description
0.0...500.0 Hz	Setting range Factory setting: 0.0 Hz

[Spd Maint Behavior] r L 5 - Menu

Access

[Complete settings] → [Error/Warning handling] → [Spd Maint Behavior]

[Spd Maint Behavior] r L 5

⚠ WARNING

LOSS OF CONTROL

- Only modify this parameter after a thorough risk assessment in compliance with all regulations and standards that apply to the device and to the application.
- Only modify this parameter from the default value if you can positively exclude that this can result in unsafe condition.
- Always consider to limit the duration of this usage by identifying and clearing, as soon as possible, the cause of the detected error

Failure to follow these instructions can result in death, serious injury, or equipment damage.

[Spd maint.] r L 5 behavior on ramp output 0.

This parameter defines the speed setpoint when the response to the [4-20mA Loss] L F L event is [Spd maint.] r L 5.

Setting	Code / Value	Description
[0]	0	The speed setpoint is 0 Factory setting
[Low speed]	r L 5	The speed setpoint equals the value of the [Low Speed] L 5 P when the speed reference is 0 Hz before the [4-20mA] L F L , event

[Fieldbus monitoring] 5 5 5 - Menu

Access

[Complete settings] → [Error/Warning handling] → [Fieldbus monitoring]

[Modbus Error Resp] 5 5 5

Response to Modbus interruption.

⚠ WARNING
<p>LOSS OF CONTROL</p> <p>If this parameter is set to [Ignore] NO, Modbus communication monitoring is disabled.</p> <ul style="list-style-type: none"> • Only use this setting after a thorough risk assessment in compliance with all regulations and standards that apply to the device and to the application. • Only use this setting for tests during commissioning. • Verify that communication monitoring has been re-enabled before completing the commissioning procedure and performing the final commissioning test. <p>Failure to follow these instructions can result in death, serious injury, or equipment damage.</p>

Behavior of the drive in the event of a communication interruption with integrated Modbus.

Setting	Code / Value	Description
[Ignore]	NO	Detected error ignored
[Freewheel]	YES	Freewheel stop Factory setting
[Per STT]	5 5 5	Stop according to configuration of [Type of stop] 5 5 5 , without tripping. In this case, the error relay does not open and the drive is ready to restart as soon as the detected error disappears, according to the restart conditions of the active command channel (for example, according to [2/3-wire control] 5 5 5 and [2-wire type] 5 5 5 if control is via the terminals) ⁽¹⁾
[fallback spd]	LF F	Change to fallback speed, maintained as long as the detected error persists and the run command has not been removed ⁽¹⁾
[Spd maint.]	RL S	The drive maintains the speed being applied when the detected error occurred, as long as the detected error is active and the run command has not been removed ⁽¹⁾ . If the run order is removed and a new run order is given while the error is still active, the speed setpoint is defined by [Spd Maint Behavior] RL S : <ul style="list-style-type: none"> • [Spd Maint Behavior] RLS=0, then the speed setpoint is 0 Hz • [Spd Maint Behavior] RLS=LSp, then the speed setpoint is the value of the [Low Speed] L 5 P parameter.
[Ramp stop]	RP P	Stop on ramp
[Fast stop]	F 5 5	Fast stop
[DC injection]	DC I	DC injection stop. This type of stop cannot be used with some other functions

(1) Because, in this case, the detected error does not trigger a stop, it is advisable to assign a relay or digital output to its indication.

[Fallback Speed] *L F F*

Fall back speed.

Setting	Description
0.0...500.0 Hz	Setting range Factory setting: 0.0 Hz

[Fallback Channel] *R F F L*

Fieldbus communication loss fallback channel.

Automatic fallback behavior in case of fieldbus communication interruption.

For more information about this parameter refer to **[Fallback Channel] *R F F L***, page 556.

[Embedded Modbus TCP] E 7 E C - Menu

Access

[Complete settings] → [Error/Warning handling] → [Embedded Modbus TCP]

[Eth Error Response] E 4 H L

Ethernet error response.

▲ WARNING	
LOSS OF CONTROL	
If this parameter is set to [Ignore] NO, Ethernet communication monitoring is disabled.	
<ul style="list-style-type: none"> • Only use this setting after a thorough risk assessment in compliance with all regulations and standards that apply to the device and to the application. • Only use this setting for tests during commissioning. • Verify that communication monitoring has been re-enabled before completing the commissioning procedure and performing the final commissioning test. 	
Failure to follow these instructions can result in death, serious injury, or equipment damage.	

The error response to a communication interruption is effective if the communication channel is involved in the active command channel.

Setting	Code / Value	Description
[Ignore]	n o	Detected error ignored
[Freewheel]	4 E 5	Freewheel stop Factory setting
[Per STT]	5 E E	Stop according to configuration of [Type of stop] 5 E E, without tripping. In this case, the error relay does not open and the drive is ready to restart as soon as the detected error disappears, according to the restart conditions of the active command channel (for example, according to [2/3-wire control] E C C and [2-wire type] E C E if control is via the terminals) ⁽¹⁾
[fallback spd]	L F F	Change to fallback speed, maintained as long as the detected error persists and the run command has not been removed ⁽¹⁾
[Spd maint.]	r L 5	The drive maintains the speed being applied when the detected error occurred, as long as the detected error is active and the run command has not been removed ⁽¹⁾ . If the run order is removed and a new run order is given while the error is still active, the speed setpoint is defined by [Spd Maint Behavior] r L 5: <ul style="list-style-type: none"> • [Spd Maint Behavior] RLS=0, then the speed setpoint is 0 Hz • [Spd Maint Behavior] RLS=LSp, then the speed setpoint is the value of the [Low Speed] L 5 P parameter.
[Ramp stop]	r 7 P	Stop on ramp
[Fast stop]	F 5 E	Fast stop
[DC injection]	d C ,	DC injection stop. This type of stop cannot be used with some other functions
<p>(1) Because, in this case, the detected error does not trigger a stop, it is advisable to assign a relay or digital output to its indication.</p>		

[Fallback Speed] *L F F ★*

Fall back speed.

Setting	Description
0.0...500.0 Hz	Setting range Factory setting: 0.0 Hz

[Fallback Channel] *R F F L*

Fieldbus communication loss fallback channel.

Automatic fallback behavior in case of fieldbus communication interruption.

For more information about this parameter refer to **[Fallback Channel]** *R F F L*, page 556.

[Communication module] 5 5 5 - Menu

Access

[Complete settings] → [Error/Warning handling] → [Communication module]

[Fieldbus Interrupt Resp] 5 5 5

⚠ WARNING

LOSS OF CONTROL

If this parameter is set to **[Ignore] NO**, fieldbus module communication monitoring is disabled.

- Only use this setting after a thorough risk assessment in compliance with all regulations and standards that apply to the device and to the application.
- Only use this setting for tests during commissioning.
- Verify that communication monitoring has been re-enabled before completing the commissioning procedure and performing the final commissioning test.

Failure to follow these instructions can result in death, serious injury, or equipment damage.

Response to fieldbus module communication interruption.

Setting	Code / Value	Description
[Ignore]	n o	Detected error ignored
[Freewheel]	y e s	Freewheel stop Factory setting
[Per STT]	5 5 5	Stop according to configuration of [Type of stop] 5 5 5 , without tripping. In this case, the error relay does not open and the drive is ready to restart as soon as the detected error disappears, according to the restart conditions of the active command channel (for example, according to [2/3-wire control] 5 5 5 and [2-wire type] 5 5 5 if control is via the terminals) ⁽¹⁾
[fallback spd]	L F F	Change to fallback speed, maintained as long as the detected error persists and the run command has not been removed ⁽¹⁾
[Spd maint.]	r L S	The drive maintains the speed being applied when the detected error occurred, as long as the detected error is active and the run command has not been removed ⁽¹⁾ . If the run order is removed and a new run order is given while the error is still active, the speed setpoint is defined by [Spd Maint Behavior] r L S : <ul style="list-style-type: none"> • [Spd Maint Behavior] RLS=0, then the speed setpoint is 0 Hz • [Spd Maint Behavior] RLS=LSp, then the speed setpoint is the value of the [Low Speed] L S P parameter.
[Ramp stop]	r n p	Stop on ramp
[Fast stop]	F S 5	Fast stop
[DC injection]	d c i	DC injection stop. This type of stop cannot be used with some other functions

(1) Because, in this case, the detected error does not trigger a stop, it is advisable to assign a relay or digital output to its indication.

[CANopen Error Resp] C 5 L

▲ WARNING
<p>LOSS OF CONTROL</p> <p>If this parameter is set to [Ignore] NO, CANopen communication monitoring is disabled.</p> <ul style="list-style-type: none"> • Only use this setting after a thorough risk assessment in compliance with all regulations and standards that apply to the device and to the application. • Only use this setting for tests during commissioning. • Verify that communication monitoring has been re-enabled before completing the commissioning procedure and performing the final commissioning test. <p>Failure to follow these instructions can result in death, serious injury, or equipment damage.</p>

Response to CANopen error.

Behavior of the drive in the event of a communication interruption with CANopen®.

Possible settings: Identical to **[Fieldbus Interrupt Resp] C L L**.

Factory setting: **[Freewheel Stop] 4 E 5**

[Eth Error Response] E 4 H L

▲ WARNING
<p>LOSS OF CONTROL</p> <p>If this parameter is set to [Ignore] NO, Ethernet communication monitoring is disabled.</p> <ul style="list-style-type: none"> • Only use this setting after a thorough risk assessment in compliance with all regulations and standards that apply to the device and to the application. • Only use this setting for tests during commissioning. • Verify that communication monitoring has been re-enabled before completing the commissioning procedure and performing the final commissioning test. <p>Failure to follow these instructions can result in death, serious injury, or equipment damage.</p>

Response to Ethernet error.

The error response to a communication interruption is effective if the communication channel is involved in the active command channel.

Possible settings: Identical to **[Fieldbus Interrupt Resp] C L L**.

Factory setting: **[Freewheel Stop] 4 E 5**

[Fallback Speed] L F F ★

Fall back speed.

Setting	Description
0.0...500.0 Hz	Setting range Factory setting: 0.0 Hz

[Fallback Channel] *R F F L*

Fieldbus communication loss fallback channel.

Automatic fallback behavior in case of fieldbus communication interruption.

If this feature is enabled, in case of communication interruption, **[Freq Switch Assign]** *r F C* and **[Command Switching]** *C C S* are both forced to channel 1 or channel 2 (depending on **[Fallback Channel]** *R F F L* configuration) while the communication interruption is active. During this fallback behavior **[Fallback Channel]** *R F F L* warning remains active.

It is required to not use continuously the fallback mode. The cause of the communication interruption must be analyzed and cleared to switch back to normal operation using fieldbus.

▲ WARNING

WRONG BEHAVIOR

- Only modify this parameter from the default value after a thorough risk assessment in compliance with all regulations and standards that apply to the device and to the application.
- Only modify this parameter from the default value if you can positively exclude that this can result in unsafe conditions.
- Perform a comprehensive commissioning test to verify correct operation of the application when fallback mode is active.

Failure to follow these instructions can result in death, serious injury, or equipment damage.

This parameter can be accessed if **[Access Level]** *L R C* is set to **[Expert]** *E P r*.

This feature is incompatible with 2-wire control on level (i.e. this parameter is forced to **[Not Active]** *n o* if **[2-wire Type]** *t C t* is set to **[Level]** *L E L* or **[Level With Fwd Priority]** *P F o*).

Setting	Code / Value	Description
[Not Active]	<i>n o</i>	Feature disabled. ⁽¹⁾ Factory setting
[Fallback To CH1]	<i>C H 1</i>	Fallback to channel 1. ⁽²⁾
[Fallback To CH2]	<i>C H 2</i>	Fallback to channel 2. ⁽²⁾

(1): If this parameter is switched back to **[Not Active]** *n o*, verify that the settings of the parameters listed below are configured accordingly with the application requirements.

(2): According to the channel switched on in case of communication interruption, the related communication monitoring parameters must be disabled manually.

List of parameters:

- **[Modbus Error Resp]** *S L L*,
- **[Fieldbus Interrupt Resp]** *C L L*,
- **[CANopen Error Resp]** *C o L*,
- **[Eth Error Response]** *E t H F*.

[Undervoltage handling] *U5B* - Menu

Access

[Complete settings] → [Error/Warning handling] → [Undervoltage handling]

[Undervoltage Resp] *U5B*

Response to undervoltage.

Setting	Code / Value	Description
[Error Triggered]	0	The drive triggers an error (the detected error relay assigned to [Operating State Fault] <i>FLE</i> will be opened) Factory setting
[Error Triggered w/o Relay]	1	The drive triggers an error (the detected error relay assigned to [Operating State Fault] <i>FLE</i> remains closed)
[Warning Triggered]	2	The warning and detected error relay remain closed. The warning can be assigned to a digital output or a relay

[Mains Voltage] *U r E5*

Rated voltage of the mains supply in Vac.

The factory setting value of this parameter depends of drive rating.

Settings	Code / Value	Description
[200 Vac]	200	200 Vac
[220 Vac]	220	220 Vac
[230 Vac]	230	230 Vac
[240 Vac]	240	240 Vac
[380 Vac]	380	380 Vac
[400 Vac]	400	400 Vac
[415 Vac]	415	415 Vac
[440 Vac]	440	440 Vac
[460 Vac]	460	460 Vac
[480 Vac]	480	480 Vac
[525 Vac]	525	525 Vac
[575 Vac]	575	575 Vac
[600 Vac]	600	600 Vac
[690 Vac]	690	690 Vac

[Undervoltage Level] *U5L*

Undervoltage level.

The factory setting is determined by the drive voltage rating.

Setting	Description
100...354 Vac	Setting range, according to drive rating Factory setting: According to drive rating

[UnderVolt Timeout] 5 5 5

Undervoltage timeout.

Setting	Description
0.2...999.9 s	Setting range Factory setting: 0.2 s

[Stop Type PLoss] 5 5 5

Controlled stop on power loss.

Behavior in the event of the undervoltage prevention level being reached.

Setting	Code / Value	Description
[No]	n o	No action Factory setting
[DC Maintain]	n n 5	This stop mode uses the inertia of the application to maintain the control block powered, and thus to keep operational I/O state and fieldbus link as long as possible.
[Ramp stop]	r n P	Stop following an adjustable deceleration ramp [Max stop time] 5 5 n in order to help to prevent from uncontrolled stop of the application.
[Freewheel Stop]	L n F	Lock (freewheel stop) without triggering an error

[UnderV. Restart Tm] 5 5 n★

Undervoltage restart time.

This parameter can be accessed if **[CtrlStopPLoss] 5 5 5** is set to **[Ramp stop] r n P**.

The time delay before authorizing the restart after a complete stop for **[CtrlStopPLoss] 5 5 5** is set to **[Ramp stop] r n P** if the voltage has returned to normal.

Setting ()	Description
1.0...999.9 s	Setting range Factory setting: 1.0 s

[Prevention Level] 5 5 5★

Undervoltage prevention level.

This parameter can be accessed if **[CtrlStopPLoss] 5 5 5** is set to **[No] n o**.

The adjustment range and factory setting are determined by the drive voltage rating and the **[Mains Voltage] 5 5 5** value.

Setting	Description
141...414 V	Setting range Factory setting: According to drive rating

[Max Stop Time] 5 5 5★

Maximum stop time.

This parameter can be accessed if **[CtrlStopPLoss] 5 5 P** is set to **[Ramp stop] 5 5 P**.

This parameter defines the deceleration ramp time in case of mains loss. During this controlled stop, the drive is powered thanks to the inertia of the application, the motor is in generator mode. It is recommended to verify that the deceleration set is compatible with the application inertia.

Setting ()	Description
0.01...60.00 s	Setting range Factory setting: 1.00 s

[DC Bus Maintain Time] 5 5 5★

DC bus maintain time.

This parameter can be accessed if **[CtrlStopPLoss] 5 5 P** is set to **[DC Maintain] 5 5 5**.

Setting ()	Description
1...9999 s	Setting range Factory setting: 9999 s

[Ground Fault] \llcorner \llcorner \llcorner - Menu

Access

[Complete settings] → [Error/Warning handling] → [Ground Fault]

About This Menu

This menu can be accessed if [Access Level] is set to [Expert] \llcorner \llcorner \llcorner

If the internal ground fault detection [Ground Fault Activation] \llcorner \llcorner \llcorner causes unwanted results in your application, it is possible to substitute the internal ground fault detection by an appropriate external ground fault monitoring system. Setting the parameter [Ground Fault Activation] \llcorner \llcorner \llcorner to [Disable Error Detect] \llcorner \llcorner \llcorner or to a percentage value of the nominal current of the drive disables the internal ground fault detection of the drive or reduces its effectiveness. Therefore, you must install an external ground fault detection system that is able to reliably detect ground faults.

DANGER

GROUND FAULT MONITORING DISABLED

- Only set the parameter [Ground Fault Activation] \llcorner \llcorner \llcorner to [Disable Error Detect] \llcorner \llcorner \llcorner or to a percentage value of the nominal current of the drive after a thorough risk assessment in compliance with all regulations and standards that apply to the device and to the application.
- Implement an alternative, external ground fault monitoring function that allows for an adequate, equivalent response to a ground fault of the drive in compliance with all applicable regulations and standards as well as the risk assessment.
- Commission and test the system with all monitoring functions enabled.
- During commissioning, verify that the alternative, external ground fault detection system properly detects any type of ground faults by performing tests and simulations in a controlled environment under controlled conditions.

Failure to follow these instructions will result in death or serious injury.

[Ground Fault Activation] \llcorner \llcorner \llcorner

Ground fault error response.

NOTE: The setting of this parameter is taken into account after a product restart.

Setting	Code / Value	Description
[ErrorDetect Disable]	\llcorner \llcorner \llcorner	Disables error detection
[Yes]	\llcorner \llcorner \llcorner	Use product internal value. Around 25% of the drive nominal current. Factory setting
0.0...100.0%	_	Setting range, in % of the drive nominal current

[Motor thermal monit] ⌂ H ⌂ - Menu

Access

[Complete settings] → [Error/Warning handling] → [Motor thermal monit]

About this Menu

Motor thermal protection by calculating the I^2t .

NOTE: The motor thermal state is memorized when the drive is switched off. The power-off time is used to calculate the motor thermal state at the next startup.

- Self-cooled motors: The trigger curves depend on the motor frequency.
- Forced-cooled motors: Only the 50 Hz trigger curves needs to be considered, regardless of the motor frequency.

Below a curve for 50Hz motor.

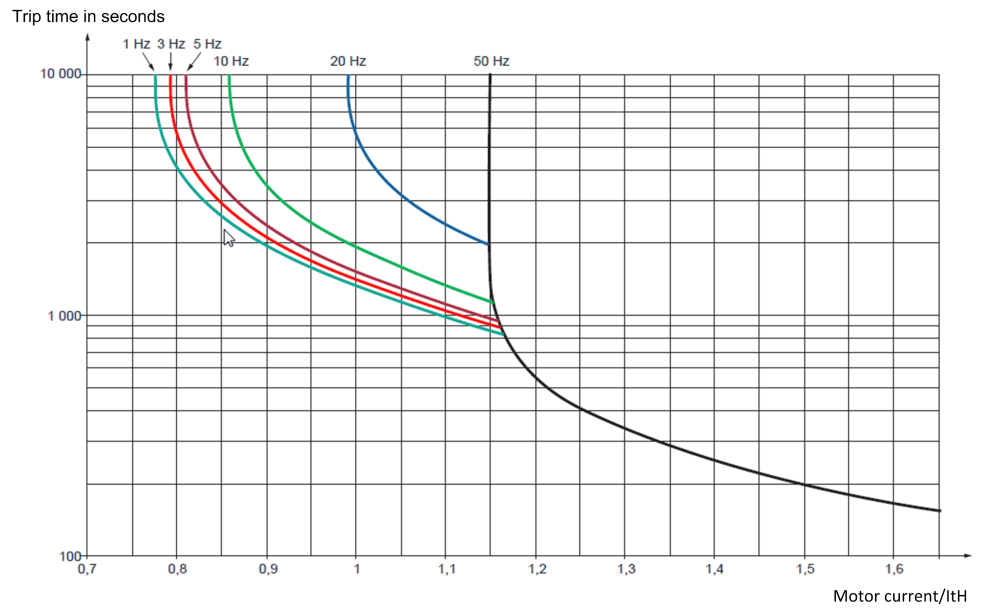

Below a curve for 60Hz motor.

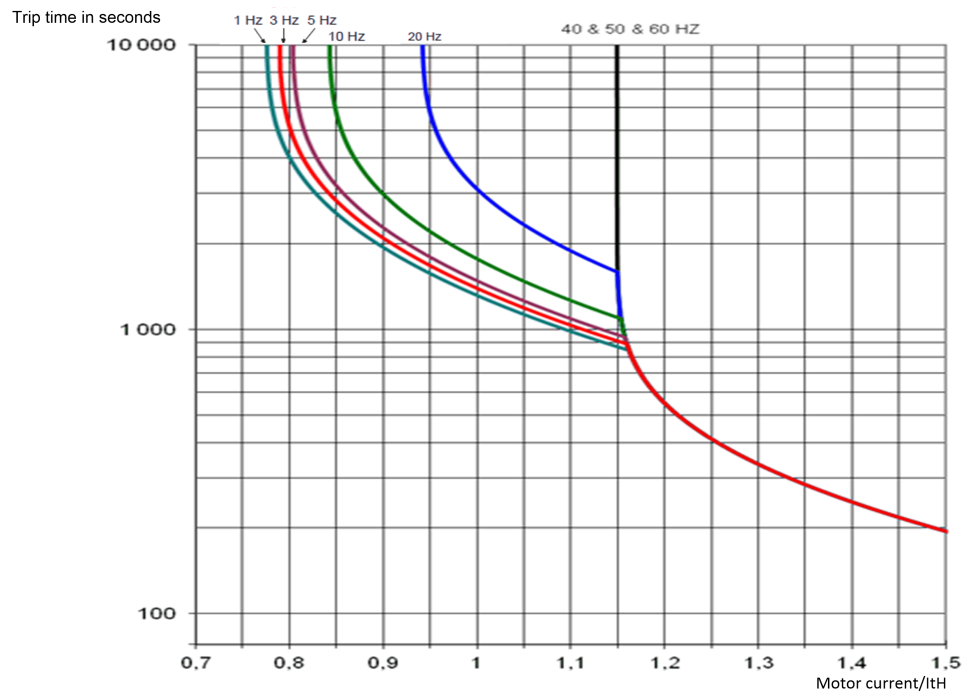

[Motor Th Current] , L H

Motor thermal monitoring current to be set to the rated current indicated on the nameplate.

Setting ()	Description
0.12...1.1_In ⁽¹⁾	Setting range Factory setting: According to drive rating
(1) Corresponding to the rated drive current indicated in the installation manual and on the drive nameplate.	

[Motor Thermal Mode] L H L

Motor thermal monitoring mode.

NOTE: An error is detected when the thermal state reaches 118% of the rated state and reactivation occurs when the state falls back below 100%.

Setting	Code / Value	Description
[No]	n o	No thermal monitoring
[Self cooled]	R C L	Self ventilated motor Factory setting
[Force-cool]	F C L	Fan-cooled motor

[Drive overload monit] 0 b r - Menu

Access

[Complete settings] → [Error/Warning handling] → [Drive overload monit]

[DriveTemp ErrorResp] 0 H L

Drive overtemperature error response.

Setting	Code / Value	Description
[Ignore]	n 0	Detected error ignored
[Freewheel]	y E 5	Freewheel stop Factory setting
[Per STT]	5 5 5	Stop according to configuration of [Type of stop] 5 5 5, without tripping. In this case, the error relay does not open and the drive is ready to restart as soon as the detected error disappears, according to the restart conditions of the active command channel (for example, according to [2/3-wire control] 5 5 5 and [2-wire type] 5 5 5 if control is via the terminals) ⁽¹⁾
[fallback spd]	L F F	Change to fallback speed, maintained as long as the detected error persists and the run command has not been removed ⁽¹⁾
[Spd maint.]	r L 5	The drive maintains the speed being applied when the detected error occurred, as long as the detected error is active and the run command has not been removed ⁽¹⁾ . If the run order is removed and a new run order is given while the error is still active, the speed setpoint is defined by [Spd Maint Behavior] r L 5: <ul style="list-style-type: none"> • [Spd Maint Behavior] RLS=0, then the speed setpoint is 0 Hz • [Spd Maint Behavior] RLS=LSp, then the speed setpoint is the value of the [Low Speed] L 5 P parameter.
[Ramp stop]	r P P	Stop on ramp
[Fast stop]	F 5 5	Fast stop
[DC injection]	d C ,	DC injection stop. This type of stop cannot be used with some other functions
<p>(1) Because, in this case, the detected error does not trigger a stop, it is advisable to assign a relay or digital output to its indication.</p>		

[Drv Thermal Warning] 5 H A

Drive thermal state warning (for [Drv Therm Thd reached] 5 A d warning).

Setting ()	Description
0...118%	Setting range Factory setting: 100%

[Warn grp 1 definition] A I Ⓛ - to [Warn grp 5 definition] A 5 Ⓛ - Menus

Access

[Complete settings] → [Error/Warning handling] → [Warning groups config]
→ [Warn grp 1 definition] to [Warn grp 5 definition]

About This Menu

The following submenus group the warnings into 1 to 5 groups, each of which can be assigned to a relay or a digital output for remote signaling.

When one or a number of warnings selected in a group occur, this warning group is activated.

List of Warnings

The list of warning codes is available in the chapter "Diagnostics and Troubleshooting".

[Error/Warning Handling] *Ⓛ 5 W Ⓝ - menu*

Access

[Complete Settings] → [Error/Warning Handling]

About This Menu

Following parameters can be accessed on ATV●60, ATV●80, ATV●A0, ATV●B0, or ATV●L0, equipped with cabinet IO, and if [Access Level] *Ⓛ Ⓜ Ⓛ* is set to [Expert] *Ⓔ Ⓟ Ⓡ*.

[Cabinet I/O 24V Timeout] *Ⓟ 2 4 Ⓛ*

Cabinet I/O 24V missing error timeout

Settings	Description
[Warning] <i>Ⓝ Ⓟ</i>	Detected error ignored. [Cab I/O 24V Warn] <i>Ⓟ 2 4 Ⓛ</i> warning is triggered.
0...3,000 s (step: 1 s)	Delay before triggering a [Cab I/O 24V Error] <i>Ⓟ 2 4 Ⓛ</i> error after [Cab I/O 24V Warn] <i>Ⓟ 2 4 Ⓛ</i> warning has been triggered. Factory setting: 3 s

[Cabinet Overheat Resp] *Ⓛ H Ⓡ*

Cabinet Overheating Response.

This parameter is used to configure the response to [Cabinet Overheat Error] *Ⓛ H Ⓡ* error.

Setting	Code / Value	Description
[No]	<i>Ⓝ Ⓟ</i>	Ignored.
[Warning]	<i>Ⓜ Ⓛ Ⓡ Ⓝ</i>	[Cabinet Overheat Warn] <i>Ⓛ H Ⓡ</i> warning is triggered and the drive remains in operation enable.
[Error]	<i>Ⓡ Ⓛ Ⓛ</i>	The drive stops the application and [Cabinet Overheat Error] <i>Ⓛ H Ⓡ</i> error is triggered. Factory setting ⁽¹⁾
[Warning Then Error]	<i>Ⓜ Ⓛ Ⓡ Ⓛ Ⓛ</i>	The drive remains in operation enable for 10 minutes (with [Cabinet Overheat Warn] <i>Ⓛ H Ⓡ</i> warning active) then [Cabinet Overheat Error] <i>Ⓛ H Ⓡ</i> error is triggered and the drive stops the application.

⁽¹⁾: The factory setting switches to [Warning Then Error] *Ⓜ Ⓛ Ⓡ Ⓛ Ⓛ* with ATV●L0.

[ON lock settings] L K 0 n - Menu

Access

[Complete settings] → [Error/Warning Handling] → [ON lock settings]

About This Menu

The “On lock” function helps to prevent the drive to start if the system is not ready to switch-on by meanings of the monitoring of drive-related devices (such as external auxiliary contacts, control voltages, cubicle fans, door contacts).

All auxiliary contacts of the external devices, which need to be monitored, are connected in series to the digital input assigned to the "ON lock" function (using the parameter [ON Lock Assignment] L K 0 5).

If the drive is not running, the drive remains locked in [Freewheel] n 5 E and [ON Lock Warning] L K 0 n is active until the locking event is resolved (i.e. until all monitored contacts connected to the digital input allows the drive to be ready).

If the drive is running and locking is triggered, an error and/or a warning is triggered according to the configuration of [ON Lock Response] L K 0 r.

Below an example with “ON lock” assigned to a digital input (low level):

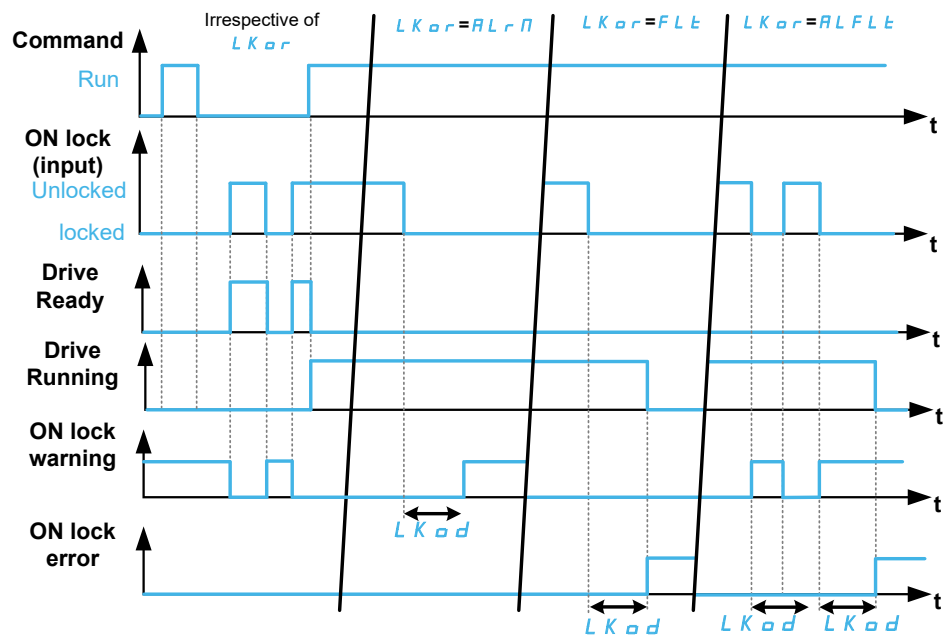

[ON Lock Assignment] L K 0 5

On lock assignment.

On locking of the drive when the assigned digital input (high level) or bit switches to 1. With low level, on locking when the digital input switches to 0.

Setting	Code / Value	Description
[Not Assigned]	n 0	Not assigned Factory setting
[DI1]...[DI6]	L , 1...L , 6	Digital input DI1...DI6
[DI11]...[DI16]	L , 11...L , 16	Digital input DI11...DI16 if VW3A3203 Extended I/O module has been inserted

Setting	Code / Value	Description
[DI1 (Low level)]...[DI6 (Low level)]	L 1 L ... L 6 L	Digital input DI1...DI6 used at low level
[DI11 (Low level)]...[DI16 (Low level)]	L 1 1 L ... L 1 6 L	Digital input DI11...DI16 used at low level if VW3A3203 Extended I/O module has been inserted
[CD00]... [CD15]	C d 0 0 ... C d 1 5	Bit x digital input ctrl word (e.g. virtual digital input CMD.00... CMD.15). NOTE: CD00...CD10 are only accessible with [Control Mode] L H C F set to [I/O Profile] 1 0 .
[C101]... [C115]	C 1 0 1 ... C 1 1 5	Bit x Modbus ctrl word (e.g. Virtual digital input CMD1.01... CMD1.15 with integrated Modbus Serial) NOTE: C101...C110 are only accessible with [Control Mode] L H C F set to [I/O Profile] 1 0 .
[C201]... [C215]	C 2 0 1 ... C 2 1 5	Bit x CANopen ctrl word (e.g. Virtual digital input CMD2.01... CMD2.15 with CANopen® fieldbus module) NOTE: C201...C210 are only accessible with [Control Mode] L H C F set to [I/O Profile] 1 0 .
[C301]... [C315]	C 3 0 1 ... C 3 1 5	Bit x Com module ctrl word (e.g. Virtual digital input CMD3.01... CMD3.15 with fieldbus module) NOTE: C301...C310 are only accessible with [Control Mode] L H C F set to [I/O Profile] 1 0 .
[C501]... [C515]	C 5 0 1 ... C 5 1 5	Bit x Ethernet ctrl word (e.g. Virtual digital input CMD3.01... CMD3.15 with Ethernet embedded) NOTE: C501...C510 are only accessible with [Control Mode] L H C F set to [I/O Profile] 1 0 .
[DI52 (High level)]...[DI59 (High level)]	d 5 2 H ... d 5 9 H	Cabinet high level digital inputs NOTE: This selection can be accessed on ATV•60, ATV•80 equipped with Cabinet IO.
[DI52 (Low level)]...[DI59 (Low level)]	d 5 2 L ... d 5 9 L	Cabinet low level assignment digital inputs NOTE: This selection can be accessed on ATV•60, ATV•80 equipped with Cabinet IO.

[ON Lock Response] L K 0 r

On lock response.

This parameter is used to set the type of ON locking event response.

This parameter can be accessed if [ON Lock Assignment] L K 0 5 is assigned.

Setting ()	Code / Value	Description
[Warning]	R L r 0	Warning: if a locking event is detected while the drive is running, [ON Lock Warning] L K 0 n is triggered after the configured time [ON Lock Time Delay] L K 0 d. It is advisable to assign a relay or digital output to its indication. NOTE: The warning is cleared as soon as the locking event is resolved. Factory setting
[Error]	F L L	Error: if the locking event is detected while the drive is running, [ON Lock Error] L K 0 n is triggered after the configured time [ON Lock Time Delay] L K 0 d.
[Warning Then Error]	R L F L L	Warning then error with time delay: if the locking event is detected while the drive is running, [ON Lock Warning] L K 0 n is triggered and, after the configured time [ON Lock Time Delay] L K 0 d, [ON Lock Error] L K 0 n is triggered. NOTE: The warning is cleared as soon as the locking event is resolved.

[ON Lock Time Delay] L K 0 d

On lock time delay.

This parameter can be accessed if [\[ON Lock Assignment\] L K 0 5](#) is assigned.

Setting 	Description
0.0...300.0 s (step: 0.1 s)	setting range Factory setting: 0.0 s

[Maintenance]

[Diagnostics] \llcorner \llcorner - Menu

Access

[Complete settings] \rightarrow [Maintenance] \rightarrow [Diagnostics]

About This Menu

This menu allows you to make simple test sequences for diagnostics.

[FAN Diagnostics] F \llcorner \llcorner

Diagnostics of internal fan(s).

This starts a test sequence.

NOTE: Fan diagnostics of internal fan(s) will be not-successful if the DC bus is not fully charged. This will be the case:

- on separate control (e.g. the control block is only supplied on 24V), or
- if the drive is in **[Energy saving]** \llcorner \llcorner \llcorner mode (e.g. Stop and go function is active).

[LED Diagnostics] H \llcorner \llcorner

Diagnostics of product LED(s).

This starts a test sequence.

[IGBT Diag w motor] \llcorner \llcorner \llcorner

Diagnostics of product IGBT(s).

This will start a test sequence with the connected motor (open circuit/short-circuit).

[IGBT Diag w/o motor] \llcorner \llcorner \llcorner

Diagnostics of product IGBT(s).

This starts a test sequence without the motor (short-circuit).

[Pump diagnostics] \llcorner \llcorner \llcorner

Diagnostics of the cooling pump. This diagnostic can only be accessed with ATV•L0.

This will start a test sequence of the cooling pump. It cannot be performed if the drive is running.

[Drive warranty mgnt] ɔW ɒ ʌ - Menu

Access

[Complete settings] → [Maintenance] → [Drive warranty mgnt]

About This Menu

The product life cycle date is initialized during product manufacturing.

A [Life Cycle Warn 1] L C ʌ 1 is triggered 2 months before the end of the warranty period. At the end of the warranty period a [Life Cycle Warn 2] L C ʌ 2 is triggered. This function requires date and time data coming from Graphic Display Terminal or a time server configured through Ethernet.

[LifeCycle Warning] L C ʌ C

Life cycle warning configuration.

Setting ()	Code / Value	Description
[No]	n o	No
[YES]	y e s	Yes Factory setting

[Warranty Expired] L C ʌ ɔ

Life cycle date.

End of warranty date (YYYY/MM/DD).

It can also be read via fieldbus communication. To convert the read value process as the following example.

Read value: 11679 → Binary conversion: **0010 1101 1001 1111** → Date: 2000 +22/12/31=2022/12/31

For more information such as its logic address, refer to the communication parameters file, page 15.

Setting	Description
YYYY/MM/DD	Setting range Factory setting: Read only.

[Customer event 1] C E I - Menu

Access

[Complete settings] → [Maintenance] → [Customer events] → [Customer event 1]

About This Menu

This menu allows you to define customized customer events based on the time.

[Config Warning 1] C C R I

Configuration of customer warning 1.

Setting	Code / Value	Description
[Not Configured]	n o	Not configured Factory setting
[Counter]	C P t	Counter
[Date And Time]	d t	Date and time

[Counter Limit 1] C C L I

Configuration counter limit 1.

Setting	Description
0...4294967295 s	Setting range Factory setting: 0 s

[Counter Source 1] C C S I

Configuration counter source 1.

Setting	Code / Value	Description
[Mains/ Control ON]	0	Mains or control supply on
[Mains Supply ON]	1	Mains supply on
[Drv In Run State]	2	Drive in running state Factory setting

[Current Counter 1] C C I

Current counter 1.

Setting	Description
0...4294967295 s	Setting range Factory setting: 0 s

[Date Time Warn 1] C d E I★

Date time warning 1.

This parameter can be accessed with the Graphic Display Terminal only.

Setting 	Description
hh:mm DD/MM/YYYY	Setting range Factory setting: 00:00 01/01/2000

[Customer event 2] C E 2 - to [Customer event 5] C E 5 - Menus**Access**

[Complete settings] → [Maintenance] → [Customer events] → [Customer event 2] to [Customer event 5]

About This Menu

Identical to [Customer event 1] C E 1 - menu , page 571.

[Config Warning 2] C C R 2 to [Config Warning 5] C C R 5

Configuration of customer warning 2 to 5.

[Counter Limit 2] C C L 2 to [Counter Limit 5] C C L 5

Configuration counter limit 2 to 5.

[Counter Source 2] C C S 2 to [Counter Source 5] C C S 5

Configuration counter source 2 to 5.

[Current Counter 2] C C 2 to [Current Counter 5] C C 5

Current counter 2 to 5.

[Date Time Warn 2] C d E 2 to [Date Time Warn 5] C d E 5★

Date time warning 2 to 5.

This parameter can be accessed with the Graphic Display Terminal only.

[Customer events] C 5 E V - Menu

Access

[Complete settings] → [Maintenance] → [Customer events]

[Warning Clearing] C A r

Customer warning clearing.

Setting ()	Code / Value	Description
[No Warning Clearing]	n o	No warning clearing Factory setting
[Clear Event 1 Warning]	r A 1	Clear event 1 warning
[Clear Event 2 Warning]	r A 2	Clear event 2 warning
[Clear Event 3 Warning]	r A 3	Clear event 3 warning
[Clear Event 4 Warning]	r A 4	Clear event 4 warning
[Clear Event 5 Warning]	r A 5	Clear event 5 warning

[Fan management] F P P P - Menu

Access

[Complete settings] → [Maintenance] → [Fan management]

About This Menu

Fan speed and [Fan Operation Time] F P b E are monitored values.

An abnormal low speed or the fan trigger a warning [Fan Feedback Warning] F F d P. As soon as [Fan Operation Time] F P b E reach the predefined value of 45,000 hours, a warning [Fan Counter Warning] F C E P is triggered.

[Fan Operation Time] F P b E counter can be set to 0 by using the [Counter Reset] r P r parameter.

Additional fan management on ATV660 and ATV680:

- If any of the cabinet fan is running at an abnormal low speed a warning [Cabinet Fan Fdbck Warn] F F C P is triggered.
- If [Cabinet Fan Oper Time] F C E has reached the predefined value of 30,000 hours, a warning [Cabinet Fan Counter Warn] F C C P is triggered.

Additional fan management on ATV680 and ATV6B0 only:

- If any of the AFE fan bricks is running at an abnormal low speed the [AFE Fan Fdbck Warn] F F b P is triggered.
- If [AFE Fan Operation Time] F b P E has reached the predefined value of 45,000 hours, a warning [AFE Fan Counter Warn] F C b P is triggered.

[Fan Mode] F F P

Fan activation mode.

NOTE: For ATV660 and ATV6A0 and ATV680 and ATV6B0, this parameter is forced to [Standard] 5 E d.

Setting ()	Code / Value	Description
[Standard]	5 E d	The operation of the fan is enabled when the motor is running. According to the drive rating, this could be the only available setting Factory setting
[Always]	r u n	The fan is always activated
[Economy]	E c o	The fan is activated only if necessary, according to the internal thermal state of the drive

[Maintenance] C 5 P A - Menu

Access

[Complete settings] → [Maintenance]

[Time Counter Reset] r P r

Time counter reset.

NOTE: The list of possible values depends on the product size.

Setting 	Code / Value	Description
[No]	n o	No Factory setting
[Run Time Reset]	r t H	Run time reset
[Power ON Time Reset]	P t H	Power ON time reset
[Reset Fan Counter]	F t H	Reset fan counter
[Clear NSM]	n S n	Clear number of motor starts
[Efficiency MAX]	E F Y K	Efficiency max
[Efficiency MIN]	E F Y J	Efficiency min
[Flow Rate MAX]	F S I K	Flow rate max
[Flow Rate MIN]	F S I J	Flow rate min
[Reset Total Quantity]	F S I C	Reset total quantity
[AFE Fan Operation Time]	F b A t	Fan operation time ⁽¹⁾
[Clear Cabinet Fan]	F C t	Clear cabinet fan operation time NOTE: This selection can be accessed on ATV660 and ATV680.
[Clear AFE Power ON Time]	b P t h	Clear AFE power ON time ⁽¹⁾
[Clear BRTH]	b r t h	Clear AFE run time ⁽¹⁾
[Clear AFE Nb. start]	b n S A	Clear AFE brick number of start ⁽¹⁾
1 This selection can be accessed on ATV680.		

[Cabinet I/O Function] C A B F -

[Monitoring circuit A] C P C A - to [Monitoring circuit D] C P C d - Menus

Access

[Complete settings] → [Cabinet I/O Function] → [Monitoring circuit A] to [Monitoring circuit D]

About These Menus

Identical to [Monitoring circuit A] C P C A - to [Monitoring circuit D] C P C d - Menus, page 541.

[Cabinet circuit A] C C P A - Menu

Access

[Complete settings] → [Cabinet I/O functions] → [Cabinet circuit A]

About This Menu

These functions can be used to manage warnings or detected errors inside the cabinet enclosure.

The cabinet circuits give the possibility to manage 2 levels of monitoring:

- A Warning level: the drive triggers an event without stopping the application.
If [CabinetCircuit ErrorResp] C F r X is set to [Ignore] n d the [CabinetCircuit Warn] C W X will be triggered.
- An Error level: the drive triggers an event and stops the application.
If [CabinetCircuit ErrorResp] C F r X is set to a different value [CabinetCircuit Error] C F X will be triggered.

Identical to [Monitoring circuit A] C P C A - menu

[CabinetCircuit A Assign] C F A A

Cabinet circuit A assignment

[CabinetCircuit A Monitor] C F P A★

Cabinet circuit A error monitoring type

[CabinetCircuit A Delay] C F d A★

Cabinet circuit A delay after Run

[CabinetCircuit A ErrorResp] C F r A★

Response to Cabinet circuit A error

[Cabinet circuit B] \llcorner \llcorner Π \llcorner - Menu

Access

[Complete settings] \rightarrow [Cabinet I/O functions] \rightarrow [Cabinet circuit B]

About This Menu

Identical to [Cabinet circuit A] \llcorner \llcorner Π \llcorner - menu

[CabinetCircuit B Assign] \llcorner \llcorner Π \llcorner

Cabinet circuit B assignment

[CabinetCircuit B Monitor] \llcorner \llcorner Π \llcorner ★

Cabinet circuit B error monitoring type

[CabinetCircuit B Delay] \llcorner \llcorner Π \llcorner ★

Cabinet circuit B delay after Run

[CabinetCircuit B ErrorResp] \llcorner \llcorner Π \llcorner ★

Response to Cabinet circuit B error

[Cabinet circuit C] \llcorner \llcorner Π \llcorner - Menu

Access

[Complete settings] \rightarrow [Cabinet I/O functions] \rightarrow [Cabinet circuit C]

About This Menu

Identical to [Cabinet circuit A] \llcorner \llcorner Π \llcorner - menu

[CabinetCircuit C Assign] \llcorner \llcorner Π \llcorner

Cabinet circuit C assignment

[CabinetCircuit C Monitor] \llcorner \llcorner Π \llcorner ★

Cabinet circuit C error monitoring type

[CabinetCircuit C Delay] \llcorner \llcorner Π \llcorner ★

Cabinet circuit C delay after Run

[CabinetCircuit C ErrorResp] ⌂ F ⌂ ⌂ ★

Response to Cabinet circuit C error

[Motor winding A] ⌂ ⌂ , ⌂ - Menu

Access

[Complete settings] → [Cabinet I/O functions] → [Motor winding A]

About This Menu

These functions will be mainly used with additional thermal relays to monitor the motor winding temperature.

These functions give the possibility to manage 2 levels of monitoring:

- A Warning level: the drive triggers an event without stopping the application.
If [MotorWinding/Bearing ErrorResp] ⌂ F r X is set to [Ignore] n ⌂ the [MotorWinding/Bearing Warn] ⌂ W X will be triggered.
- An Error level: the drive triggers an event and stops the application.
If [MotorWinding/Bearing ErrorResp] ⌂ F r X is set to a different value [MotorWinding/Bearing Error] ⌂ F X will be triggered.

Identical to [Monitoring circuit A] ⌂ ⌂ ⌂ ⌂ - menu

[MotorWinding A Assign] ⌂ F ⌂ ⌂

Motor winding A assignment

[MotorWinding A Monitor] ⌂ F ⌂ ⌂★

Motor winding A monitoring

[MotorWinding A Delay] ⌂ F ⌂ ⌂★

Motor winding A delay after Run

[MotorWinding A ErrorResp] ⌂ F r ⌂★

Response to Motor winding A error

[Motor winding B] C E , b - Menu

Access

[Complete settings] → [Cabinet I/O functions] → [Motor winding B]

About This Menu

Identical to [Motor winding A] C E , A - menu , page 579

[MotorWinding B Assign] E F A b

Motor winding B assignment

[MotorWinding B Monitor] E F A b★

Motor winding B monitoring

[MotorWinding B Delay] E F d b★

Motor winding B delay after Run

[MotorWinding B ErrorResp] E F r b★

Response to Motor winding B error

[Motor bearing A] C E , C - Menu

Access

[Complete settings] → [Cabinet I/O functions] → [Motor bearing A]

About This Menu

Identical to [Motor winding A] C E , A - menu , page 579

[MotorBearing A Assign] E F A C

Motor bearing A assignment

[MotorBearing A Monitor] E F A C★

Motor winding A monitoring

[MotorBearing A Delay] E F d C★

Motor bearing A delay after Run

[MotorBearing A ErrorResp] [L F r L](#) ★

Response to Motor bearing A error

[Motor bearing B] C E , d - Menu

Access

[Complete settings] → [Cabinet I/O functions] → [Motor bearing B]

About This Menu

Identical to [Motor winding A] C E , R - menu , page 579

[MotorBearing B Assign] E F R d

Motor bearing B assignment

[MotorBearing B Monitor] E F R d★

Motor winding B monitoring

[MotorBearing B Delay] E F d d★

Motor bearing B delay after Run

[MotorBearing B ErrorResp] E F r d★

Response to Motor bearing B error

[Circuit breaker] *C C B K - Menu*

Access

[Complete settings] → [Cabinet I/O functions] → [Circuit breaker]

About This Menu

This menu is used to control the circuit breaker behavior

This menu can be accessed on ATV660 or ATV680, equipped with Cabinet IO, and if [Access Level] *L R C* is set to [Expert] *E P r*.

[CB start pulse activated] *C B E P*

Circuit breaker start pulse assignment

Setting	Code / Value	Description
[R61 Assignment]...[R66 Assignment]	<i>r B 1...r B 6</i>	Cabinet I/O relays outputs

[CB stop pulse activated] *C B d P*

Circuit breakers stop pulse assignment

Setting	Code / Value	Description
[R61 Assignment]...[R66 Assignment]	<i>r B 1...r B 6</i>	Cabinet I/O relays outputs

[Drive Lock] *L E S*

Drive lock assignment.

This parameter can be accessed if:

- [Mains Contactor] *L L C* is assigned, or
- [CB start pulse activated] *C B E P* is assigned, or
- [CB stop pulse activated] *C B d P* is assigned.

The drive locks when the assigned input or bit changes to 0.

Setting	Code / Value	Description
[Not Assigned]	<i>n o</i>	Not assigned Factory setting
[CD00]... [CD10]	<i>C d 0 0... C d 1 0</i>	Virtual digital input CMD.0...CMD.10 in [I/O profile] <i>i o</i> configuration
[CD11]... [CD15]	<i>C d 1 1... C d 1 5</i>	Virtual digital input CMD.11...CMD.15 regardless of configuration
[C101]... [C110]	<i>C 1 0 1... C 1 1 0</i>	Virtual digital input CMD1.01...CMD1.10 with integrated Modbus Serial in [I/O profile] <i>i o</i> configuration
[C111]... [C115]	<i>C 1 1 1... C 1 1 5</i>	Virtual digital input CMD1.11...CMD1.15 with integrated Modbus Serial regardless of configuration

Setting	Code / Value	Description
[C201]... [C210]	C 2 0 1... C 2 1 0	Virtual digital input CMD2.01...CMD2.10 with CANopen® fieldbus module in [I/O profile] , 0 configuration
[C211]... [C215]	C 2 1 1... C 2 1 5	Virtual digital input CMD2.11...CMD2.15 with CANopen® fieldbus module regardless of configuration
[C301]... [C310]	C 3 0 1... C 3 1 0	Virtual digital input CMD3.01...CMD3.10 with a fieldbus module in [I/O profile] , 0 configuration
[C311]... [C315]	C 3 1 1... C 3 1 5	Virtual digital input CMD3.11...CMD3.15 with a fieldbus module regardless of configuration
[C501]... [C510]	C 5 0 1... C 5 1 0	Virtual digital input CMD5.01...CMD5.10 with integrated Ethernet Modbus TCP in [I/O profile] , 0 configuration
[C511]... [C515]	C 5 1 1... C 5 1 5	Virtual digital input CMD5.11...CMD5.15 with integrated Ethernet Modbus TCP regardless of configuration
[DI1 (Low level)]...[DI6 (Low level)]	L 1 L ... L 6 L	Digital input DI1...DI6 used at low level
[DI11 (Low level)]...[DI16 (Low level)]	L 1 1 L ... L 1 6 L	Digital input DI11...DI16 used at low level if VW3A3203 I/O extension module has been inserted
[DI52 (Low level)]...[DI59 (Low level)]	d 5 2 L ... d 5 9 L	Digital input DI52...DI59 (low level) NOTE: This selection can be accessed on ATV660 and ATV680 equipped with Cabinet IO.
[DI52 (High level)]... [DI59 (High level)]	d 5 2 H... d 5 9 H	Cabinet high level digital inputs NOTE: This selection can be accessed on ATV660 and ATV680 equipped with Cabinet IO.

[CB status] C b 5

Circuit breaker status

If [CB start pulse activated] C b E P and [CB stop pulse activated] C b d P are not configured the [CB Invalid Config] C b C , status is displayed. Both values must be set in order to configure the circuit breaker.

The [CB stop disable] C b 5 d status is displayed until [CB Disable stop delay] C b t 5 is reached.

Setting	Code / Value	Description
[CB Not Configured]	n 0	Circuit breaker not configured
[CB Invalid Config]	C b C ,	Circuit breaker invalid configuration
[CB In Start Pulse]	C b 5 t	Circuit breaker in start pulse
[CB Not Closed]	C b n C	Circuit breaker not closed
[CB Open]	C b o 5	Circuit breaker in open
[CB In Stop Pulse]	C b 5 P	Circuit breaker in stop pulse
[CB Not Open]	C b n o	Circuit breaker not open
[CB Closed]	C b C 5	Circuit breaker closed
[CB stop disable]	C b 5 d	Circuit breaker stop is disable

[CB start pulse time] C B E 1

Circuit Breaker start pulse time.

Setting	Description
0.1...60.0 s	Setting range Factory setting: 0.5 s

[CB stop pulse time] C B E 2

Circuit Breaker stop pulse time.

Identical to **[CB start pulse time] C B E 1**

[CB Switch-on delay] C B E 3

Circuit Breaker Switch-on delay.

This parameter is used to set a minimal delay between a star pulse and a stop pulse.

Identical to **[CB start pulse time] C B E 1**

[CB Switch-off delay] C B E 4

Circuit Breaker Switch-off delay.

This parameter is used to set a minimal delay between a stop pulse and a start pulse.

Identical to **[CB start pulse time] C B E 1**

[CB Disable stop delay] C B E 5

Circuit Breaker Disable stop delay.

Setting	Description
0.0...360.0 s	Setting range Factory setting: 60.0 s

[Mains V. time out] L C E

Monitoring time for closing of line contactor.

Setting	Description
1...999 s	Setting range Factory setting: 5 s

[CB Error Resp] C B S r

The Circuit breaker gives the possibility to manage 2 levels of monitoring:

- A Warning level: the drive triggers an event without stopping the application.

- An Error level: the drive triggers an event and stops the application.

If after a start command, no voltage is detected after the **[Mains V. time out]** *L L t*, the **[CB Error Resp]** *C b S r* is triggered and the **[CB Not Closed]** *C b n C* status is displayed.

If after a stop command, the voltage is still detected after **[Mains V. time out]** *L L t*, the **[CB Error Resp]** *C b S r* is triggered and the **[CB Not Open]** *C b n o* status is displayed.

Setting	Code / Value	Description
[Error]	<i>F L t</i>	The drive stops the application Factory setting
[Warning]	<i>w R r</i>	A warning is triggered and the drive remains in operation enable.

[Cabinet I/O functions] *ℓ R B F - menu*

Access

[Complete Settings] → [Cabinet I/O functions]

About This Menu

This parameter can be accessed on ATV●60, ATV●80, ATV●A0, ATV●B0, or ATV●L0, equipped with cabinet IO, and if [Access Level] *ℓ R ℓ* is set to [Expert] *ℓ P r*.

[Cabinet I/O 24V Timeout] *P 2 4 d*

Cabinet I/O 24V missing error timeout

Settings	Description
[Warning] <i>n o</i>	Detected error ignored. [Cab I/O 24V Warn] <i>P 2 4 ℓ</i> warning is triggered.
0...3,000 s	Delay before triggering a [Cab I/O 24V Error] <i>P 2 4 ℓ</i> error after [Cab I/O 24V Warn] <i>P 2 4 ℓ</i> warning has been triggered. Factory setting: 3 s

[Cabinet Overheat Resp] *ℓ H r*

Cabinet Overheating Response.

This parameter is used to configure the response to [Cabinet Overheat Error] *ℓ H F* error.

Setting	Code / Value	Description
[No]	<i>n o</i>	Ignored.
[Warning]	<i>R L r n</i>	[Cabinet Overheat Warn] <i>ℓ H R</i> warning is triggered and the drive remains in operation enable.
[Error]	<i>F L ℓ</i>	The drive stops the application and [Cabinet Overheat Error] <i>ℓ H F</i> error is triggered. Factory setting ⁽¹⁾
[Warning Then Error]	<i>R L F L ℓ</i>	The drive remains in operation enable for 10 minutes (with [Cabinet Overheat Warn] <i>ℓ H R</i> warning active) then [Cabinet Overheat Error] <i>ℓ H F</i> error is triggered and the drive stops the application.
⁽¹⁾ : The factory setting switches to [Warning Then Error] <i>R L F L ℓ</i> with ATV●L0.		

Communication

What's in This Chapter

[Communication] *C o Π* - 588

[Communication] *C o Π* -

Introduction



[Communication] *C o Π* - menu presents the fieldbus submenus.

What is in This Chapter?

This chapter contains the following topics inside [Comm parameters] *C Π P* - submenu:

Menu	Description	Related manual
[Modbus SL] <i>Π S L</i> - → [Modbus fieldbus] <i>Π d 1</i> -	This menu is related to the Modbus serial communication port at the bottom of the control block. NOTE: [Modbus add Com.C.] <i>R Π o C</i> is a parameter similar to [Modbus Address] <i>R d d</i> for Ethernet-IP Modbus TCP fieldbus.	EAV64325
[Modbus SL] <i>Π S L</i> - → [Modbus HMI] <i>Π d 2</i> -	This menu is related to the Modbus serial communication port on the front of the control block. It is used by default for the Graphic Display Terminal . The Graphic Display Terminal is only compliant with the following settings (factory settings): [HMI Baud Rate] tbr2 equal to [19200 bps] 19k2 , [Term 2 word order] tWO2 equal to [HIGH] On and [HMI Format] tFO2 equal to [8-E-1] B E I .	-
[Embd Eth Config] <i>E E E</i> -	This menu is related to the Ethernet Embedded communication.	EAV64327
[Eth Module Config] <i>E E o</i> -	This menu is related to the Ethernet-IP Modbus TCP fieldbus module (VW3A3720, VW3A3721).	EAV64328
[CANopen] <i>C n o</i> -	This menu is related to the CANopen module (VW3A3608, VW3A3618, VW3A3628).	EAV64333
[DeviceNet] <i>d n C</i> -	This menu is related to the DeviceNet fieldbus module (VW3A3609).	EAV64330
[BACnet MS/TP] <i>b A C Π</i> -	This menu is related to the BACnet MS/TP fieldbus module (VW3A3725).	QGH66984
[Profibus] <i>P b C</i> -	This menu is related to the Profibus DP fieldbus module (VW3A3607).	EAV64329

[Profinet] P n C -	This menu is related to the Profinet fieldbus module (VW3A3627).	EAV64331
[Powerlink] E P L -	This menu is related to the POWERLINK fieldbus module (VW3A3619).	PHA99690

NOTE:

- These menus can be accessed if the corresponding option has been inserted and if the firmware of the option module and the drive are compatible. In addition to the fieldbus manuals, refer to the Instruction Sheet of the option modules (S1A45591) and the installation manual of the drive for more information.
- Access to the communication parameters to carry out searches (example: parameter address and format) and sort operations (EAV64332).
- The drive needs to be restarted to apply the modification of a communication parameter.

[File management] F Π Ε -

What's in This Chapter

[Transfer config file] Ε Λ F - Menu.....	591
[Factory settings] F Λ S - Menu.....	592
[Parameter group list] F ρ Υ - Menu	593
[Factory settings] F Λ S - Menu.....	594
[Pre-settings] Ρ ρ Ε S - Menu	595
[Firmware update] F W U P - Menu.....	596

Introduction



[File management] F Π Ε - menu presents the management of drive configuration files.

[Transfer config file] E C F - Menu

Access

[File management] → [Transfer config file]

[Copy to the drive] □ P F

This allows to select a previously saved drive configuration from the Graphic Display Terminal memory and transfer it to the drive.

The drive needs to be restarted after a configuration file transfer.

[Copy from the drive] S R F

This allows to save the actual drive configuration into the Graphic Display Terminal memory.

NOTE: The Graphic Display Terminal can store up to 16 configuration files.

[Factory settings] F C 5 - Menu

Access

[File management] → [Factory settings]

About This Menu

This parameter allows to select the configuration to restore in case of factory setting operation.

[Config. Source] F C 5 , ★

Setting	Code / Value	Description
[Macro-Conf]	000	Factory setting parameter set Factory setting
[Config 1]	CFG 1	Customer parameter set 1
[Config 2]	CFG 2	Customer parameter set 2
[Config 3]	CFG 3	Customer parameter set 3

[Parameter group list] F r Y - Menu

Access

[File management] → [Factory settings] → [Parameter group list]

About This Menu

Selection of menus to be loaded.

NOTE: In factory configuration and after a return to "factory settings", [Parameter group list] F r Y will be empty.

[All] R L L

All parameters in all menus.

[Drive Configuration] d r P

Load [Complete settings] C S E - menu.

[Motor Param] P o t

Load [Motor parameters] P P R - menu.

[Comm. Menu] C o P★

Load [Communication] C o P - menu.

This parameter can be accessed if [Config. Source] F C 5 , is set to [Macro-Conf] i n i .

[Display Config.] d , S★

Load [Display screen type] P S E - menu.

This parameter can be accessed if [Config. Source] F C 5 , is set to [Macro-Conf] i n i .

[Factory settings] F [5 - Menu

Access

[File management] → [Factory settings]

[Go to Factory settings] [F 5

⚠ WARNING

UNANTICIPATED EQUIPMENT OPERATION

Verify that restoring the factory settings is compatible with the type of wiring used.

Failure to follow these instructions can result in death, serious injury, or equipment damage.

It is only possible to revert to the factory settings if at least one group of parameters has previously been selected.

[Save Configuration] S [5 , ★

Save configuration.

The active configuration to be saved does not appear for selection. For example, if it is [Config 0] S E r 0, only [Config 1] S E r 1, [Config 2] S E r 2 and [Config 3] S E r 3 appear. The parameter changes back to [No] n o as soon as the operation is complete.

Setting	Code / Value	Description
[No]	n o	No Factory setting
[Config 0]	S E r 0	Store customer parameter set 0
[Config 1]	S E r 1	Store customer parameter set 1
[Config 2]	S E r 2	Store customer parameter set 2
[Config 3]	S E r 3	Store customer parameter set 3

[Pre-settings] P r E S - Menu

Access

[File management] → [Factory settings] → [Pre-settings]

About This Menu

ATV660 and ATV680 give possibility to defined pre-settings for drive parameters.

It allows pre configuration and protection from modifications of:

- Drive functions
- Cabinet I/O functions

This pre-setting is done during the manufacturing of the drive system.

[Pre-settings Status] P S S

Drive Systems pre-settings status.

Setting	Code / Value	Description
[Not locked]	n P L E	Pre-setting configuration is not locked. Parameters defined in the pre-setting list can be modified
[Locked]	P c E	Pre-setting configuration is locked. Parameters defined in the pre-setting list cannot be modified

[Pre-settings Unlock] P S r E

Drive Systems pre-settings unlock.

This parameter can be used, by a Schneider Electric representative, to unlock the pre-setting configuration.

Setting	Description
0...65535	Setting range Factory setting: 0

[Firmware update] F W U P - Menu

Access

[File management] → [Firmware update]

About This Menu

This function is used to update the software of the drive and can only be used by Schneider Electric Services.

For more information contact your local Schneider Electric Services.

[My preferences] ПУР -

What's in This Chapter

[Language]	597
[Password]	598
[Parameter access]	600
[Customization]	602
[Date & Time settings]	605
[Access level] L A C - Menu	606
[Webserver]	607
[Functions key mgnt]	609
[LCD settings]	610
[Stop and go]	611
[QR code]	615
[Pairing password]	616

Introduction



[My preferences] ПУР - menu presents the possible settings for the user-defined HMI and parameter access.

[Language]

[Language] L A C - Menu

Access

[My preferences] → [Language]

About This Menu

This menu allows to select the Graphic Display Terminal language.

[Password]

[Password] C o d - Menu

Access

[My preferences] → [Password]

About This Menu

Enables the configuration to be protected with an access code or a password to be entered in order to access a protected configuration:

- The drive is unlocked when the password is set to **[No password defined]** n o or when the correct password has been entered. All menus can be accessed.
- Before protecting the configuration with a password, you must:
 - Define the **[Upload rights]** u L r and **[Download rights]** d L r .
 - Make a careful note of the password and keep it in a place where you are able to find it.

Locking the drive modifies the menu access. If the password is locked:

- **[My Menu]** П У П n - menu (in **[Simply Start]** S У S - menu) remains visible if not empty,
- **[Dashboard]** d S H - , **[Diagnostics]** d , R - and **[Display]** П o n - menus remain visible with the read-only parameters. Sub-menus with settable parameters are not visible.
- **[Complete Settings]** C S t - and **[Communication]** C o П - menus are not visible,
- **[Transfer config file]** t C F - menu (in **[File Management]** F П t - menu) remains visible.
- in the **[My preferences]** П У Р - menu, remains visible:
 - **[Language]** L n G ,
 - **[Password]** C o d - menu,
 - **[Display screen Type]** П S C - menu (in **[Customization]** C u S - menu),
 - **[Date & Time settings]** r t C ,
 - **[Access Level]** L R C , and
 - **[LCD settings]** C n L - menu.

[Password status] P S S t

Password status.

Read only parameter.

Setting	Code / Value	Description
[No password defined]	n o	No password defined Factory setting
[Password is unlocked]	u L	Password is unlocked
[Password is locked]	L o C	Password is locked

[Password] Pw d

6-characters password. To lock the drive, define and enter your password.
[Password status] P 5 5 E value switches to **[Password is locked] L o C**.

To unlock the drive, the password must be entered. Once the correct code has been entered, the drive is unlocked and **[Password status] P 5 5 E** value switches to **[Password is unlocked] u L**. Access will be locked again the next time the drive is switched on.

To modify the password, unlock the drive then enter the new password. Entering a new password locks the drive.

To remove the password, the drive must be unlocked and the password 000000 must be entered. **[Password status] P 5 5 E** value switches to **[No password defined] n o**. At next switch-on, the drive remains unlocked.

[Upload rights] u L r

Upload rights.

Setting 	Code / Value	Description
[Permitted]	u L r D	Commissioning tools or the Graphic Display Terminal can save the whole configuration (password, monitoring, configuration) Factory setting
[Not allowed]	u L r I	Commissioning tools or the Graphic Display Terminal cannot save the configuration if the drive is not protected by a password or if the in-correct password has been entered

[Download rights] d L r

Download rights.

Setting 	Code / Value	Description
[Locked drv]	d L r D	Lock drive: the configuration can be downloaded to the drive only if the drive is protected by a password, which is the same as the password of the configuration to be downloaded
[Unlock. drv]	d L r I	Unlock drive: the configuration can be downloaded to the drive or a configuration can be modified if the drive is unlocked or is not protected by a password Factory setting
[Not allowed]	d L r 2	The configuration cannot be downloaded
[Lock/unlock]	d L r 3	Combination of [Locked drv] d L r D and [Unlock. drv] d L r I

[Parameter access]

[Restricted channels] P C d - Menu

Access

[My preferences] → [Parameter access] → [Restricted access] → [Restricted channels]

About This Menu

Following channels can be selected to disable the accessibility to the related parameters.

[HMI] C o n

Graphic Display Terminal.

[PC Tool] P W S

DTM-based commissioning software.

[Modbus] П d b

Embedded Modbus serial.

[CANopen] C A n

CANopen fieldbus module.

[Com. Module] n E t

Fieldbus option module.

[Restricted param] P P R - Menu

Access

[My preferences] → [Parameter access] → [Restricted access] → [Restricted param]

About This Menu

In these screens, all parameters in the **[Complete settings] C S E** - menu can be protected and are displayed for selection, except for the Expert parameters.

Press the **All** key to select all the parameters. Press the **None** key again to deselect all the parameters.

Content of the **[Complete settings] C S E** - menu. No selections can be made in this screen if there are no parameters.

[Visibility] V , S - Menu

Access

[My preferences] → [Parameter access] → [Visibility]

About This Menu

Selection to display all parameters or only the active parameters.

[Parameters] P V , S

Parameters.

Setting	Code / Value	Description
[Active]	<i>A C L</i>	Only active parameters can be accessed Factory setting
[All]	<i>A L L</i>	All parameters can be accessed

[Customization]

[My menu config.] ПУС - Menu

Access

[My preferences] → [Customization] → [My menu config.]

About This Menu

This menu allows to customize the [My menu] ПУПН - Menu, page 56.

[Parameter Selection] ППР

This menu shows the content of [Complete settings] ССЛ - menu and it allows to:

- Select the parameters visible in [My Menu] ПУПН -, and
- Remove the selected visible parameters from [My Menu] ПУПН - .

No selection can be made if there are no parameters in the displayed current screen.

[Display Selection] ПДР

This menu shows the content of [Display] ПОН - menu and it allows to:

- Select the parameters visible in [My Menu] ПУПН -, and
- Remove the selected visible parameters from [My Menu] ПУПН - .

No selection can be made if there are no parameters in the displayed current screen.

[Selected List] ППЛ

This menu displays the parameters selected via [Parameter Selection] ППР and [Display Selection] ПДР .

With the Graphic Display Terminal, this menu allows to sort and remove the selected parameters using the function keys (F1, F2 and F3).

NOTE: Up to 25 parameters can be selected to be displayed in the customized menu..

[My Menu] ПУПН

Used to define the name of the customized menu.

[Display screen type] П5С - Menu

Access

[My preferences] → [Customization] → [Display screen type]

About This Menu

This parameter allows to select the type of display for the default screen.

[Display value type] ПДТ

Type of screen display.

Setting (↻)	Code / Value	Description
[Digital]	дЕС	Digital values Factory setting
[Bar graph]	бар	Bar graph
[List]	Л, СТ	List of values
[Vu Meter]	ВУМЕТ	Vu meter

[Parameter Selection] ПРС

Customized selection.

This view allows to select the parameters to display on the default screen.

[Param. Bar Select] РБС - Menu

Access

[My preferences] → [Customization] → [Param. Bar Select]

About This Menu

This view allows to select the parameters to display on the top line of the Graphic Display Terminal screen.

[Customer parameters] C Y P - Menu

Access

[My preferences] → [Customization] → [Customer parameters]

About This Menu

This menu allows to rename up to 15 parameters.

[Parameter Selection] S C P

Parameter selection.

This view allows to select up to 15 parameters.

[Custom Selection] C P П

Customized selection.

This view allows to set for each selected parameter:

- The name
- The unit if relevant (a custom unit is available)
- A multiplier (1...1000) if relevant
- A divisor (1...1000) if relevant
- An offset (-99.00...99.00) if relevant

[Service message] S E P - Menu

Access

[My preferences] → [Customization] → [Service message]

About This Menu

This menu allows to define a user-defined service message (5 lines, 23 digits per line).

This defined message is displayed in [Diagnostics] d , P - → [Diag. data] d d t - → [Service message] S E P - submenu , page 74.

[LINE 1] S П L O 1 to [LINE 5] S П L O 5

Line 1 to line 5.

These elements are used to define line-by-line the content of the service message.

[Date & Time settings]

[Date/time settings] r t [- Menu

Access

[My preferences] → [Date/time settings]

About This Menu

This view allows to set date and time. This information is used for the time stamping of all logged data.

If a time server is connected over Ethernet and configured in the webserver, date and time data are updated automatically according to the configuration.

Date and time information shall be available (time server available and configured, or Graphic Display Terminal plugged) at drive power up to enable the time stamping of the logged data.

Modifying these settings will modify previously logged data value in case of average data based on time.

[Access level] L R C - Menu

Access

[My preferences] → [Access level]

[Access Level] L R C

Access level: to define the level of access control.

Setting ()	Code / Value	Description
[Basic]	<i>b R S</i>	Access to the [Simply start] <i>S Y S</i> -, [Dashboard] <i>d S H</i> -, [Diagnostics] <i>d i A</i> -, and [My preferences] ПУР - menus only.
[Standard]	<i>S E d</i>	Access to all menus including [Display] <i>П о н</i> -, [Complete settings] <i>С S E</i> -, [Communication] <i>С о П</i> -, [My preferences] ПУР - and [File management] <i>F П E</i> -. Factory setting
[Expert]	<i>E P r</i>	Access to all menus and to additional parameters.

[Webserver]

[Webserver] WBS - Menu

Access

[My preferences] → [Webserver]

About This Menu

This menu allows to manage Web services.

For more information refer to the Ethernet fieldbus manuals, page 15.

[EnableEmbWeb] EWEE

Enable Embedded Webserver.

Enable Web services for the embedded Ethernet adapter.

Setting	Code / Value	Description
[No]	no	Webserver disabled
[Yes]	YES	Webserver enabled Factory setting

[EnableOptWeb] EWEE★

Enable Option Webserver.

Enable Web services for the Ethernet option module.

This parameter can be accessed if W3A3720–21 Ethernet-IP Modbus TCP fieldbus module has been inserted.

Setting	Code / Value	Description
[No]	no	Webserver disabled
[Yes]	YES	Webserver enabled Factory setting

[Reset Eth Embd Pwd] RWPE

Reset ethernet embedded password.

For embedded ethernet, it resets the user authentication password and the administrator access (ADMIN) webserver password to the default value. Once reset, the default password can be read using [Default Pwd Eth Embd] WdPE.

Setting ()	Code / Value	Description
[No]	no	Password reset is not requested. Factory setting
[Yes]	YES	Password reset is requested. NOTE: The parameter switches to [No] no when the operation is done.

[Reset Eth Opt Pwd] P W P O ★

Reset ethernet option password.

For ethernet option, it resets the user authentication password and the administrator access (ADMIN) webserver password to the default value. Once reset, the default password can be read using [Default Pwd Eth Opt] P W P O .

This parameter can be accessed if W3A3720–21 Ethernet-IP Modbus TCP fieldbus module has been inserted.

Setting ()	Code / Value	Description
[No]	n o	Password reset is not requested. Factory setting
[Yes]	y e s	Password reset is requested. NOTE: The parameter switches to [No] n o when the operation is done.

[Default Pwd Eth Embd] P W D P E

8-characters default password.

It shows the ethernet embedded default password used for both webserver connection (Administrator access) and user authentication.

The default password is displayed on the Graphic Display Terminal. The Graphic Display Terminal is an accessory for cabinet integration product (ATV●30●●●N4Z).

NOTE: The user authentication is a feature provided to help prevent unauthorized and malicious connection to the device. The access to the connected device via a software tool provided by Schneider Electric (such as SoMove) is restricted to authenticated users. For more information, refer to the DTM online help.

The default password must not be used. A new password must be defined after a password reset or at the first connection to the drive.

[Default Pwd Eth Opt] P W D P O

8-characters default password.

It shows the ethernet option default password used for both webserver connection (Administrator access) and user authentication.

The default password is displayed on the Graphic Display Terminal. The Graphic Display Terminal is an accessory for cabinet integration product (ATV●30●●●N4Z).

NOTE: The user authentication is a feature provided to help prevent unauthorized and malicious connection to the device. The access to the connected device via a software tool provided by Schneider Electric (such as SoMove) is restricted to authenticated users. For more information, refer to the DTM online help.

The default password must not be used. A new password must be defined after a password reset or at the first connection to the drive.

[Functions key mgnt]

[Functions key mgnt] *FKG* - Menu

Access

[My preferences] → [Functions key mgnt]

About This Menu

This menu allows to assign functions to the Graphic Display Terminal function keys.

[F1 key assignment] *F n 1* to [F4 key assignment] *F n 4*

Function key 1 to function key 4.

Following possible assignments cannot be accessed in [I/O profile] *IO* configuration.

Setting	Code / Value	Description
[Not assigned]	<i>na</i>	Not assigned Factory setting
[Preset Speed 1]	<i>F P S 1</i>	Function key preset speed 1 assignment
[Preset Speed 2]	<i>F P S 2</i>	Function key preset speed 2 assignment
[PID Ref Frequency 1]	<i>F P r 1</i>	Function key preset PID 1 assignment
[PID Ref Frequency 2]	<i>F P r 2</i>	Function key preset PID 2 assignment
[+Speed]	<i>F u S P</i>	Function key faster assignment
[-Speed]	<i>F d S P</i>	Function key slower assignment

[LCD settings]

[LCD settings] [n L - Menu

Access

[My preferences] → [LCD settings]

About This Menu

This menu allows to set the Graphic Display Terminal related parameters.

[Screen Contrast] [5 E

Screen contrast setting.

Setting	Description
0...100%	Setting range Factory setting: 50%

[Standby] 5 b Y

Stand-by delay.

NOTE: Disabling the automatic standby function of the display terminal backlight will reduce the backlight service time.

Setting	Description
n o ...10 min	Automatic backlight OFF time Factory setting: 10 min

[Display Terminal locked] K L [K

Graphic Display Terminal key locked. Press **ESC** and **Home** keys to Lock manually & unlock the Graphic Display Terminal keys. The **Stop** key remains active when the Graphic Display Terminal is locked.

Setting ()	Description
n o ...10 min	Setting range Factory setting: 5 min

[Red Backlight] b [K L ★

Graphic Display Terminal red backlight function disabled in case or an error triggered.

Setting ()	Code / Value	Description
[No]	n o	Red backlight disabled
[Yes]	Y E 5	Red backlight enabled Factory setting

[Stop and go]

[Stop and go] S E G - Menu

Access

[My preferences] → [Stop and go]

About This Menu

This function is available for all drives excepted frame size 1 to 3.

This function can be used to save energy by managing the DC bus voltage. When this function is active, [Drive State] H П, S is in [Energy Saving] , d L E mode and the DC bus voltage is no longer maintained at operational level.

A run command has priority on energy saving mode: if this function is active when a run command is requested, the drive leaves the energy saving state, the DC bus charges then the motor runs.

The DC bus charges introduces a delay on the run of the motor. If the DC bus is not charged after [Egy Saving Timeout] , d L E has elapsed, [Egy Saving Exit Error] , d L F is triggered.

There are three different modes to activate the energy saving:

- **Automatic mode:** [Energy Saving Delay] , d L П configured,
 - At drive power on, the function is active: DC bus is not charged.
 - After the motor is stopped, the energy saving mode is active after [Energy Saving Delay] , d L П.

NOTE: if a run command is requested during [Energy Saving Delay] , d L П, the DC bus is still charged: there is no delay applied on the run command.

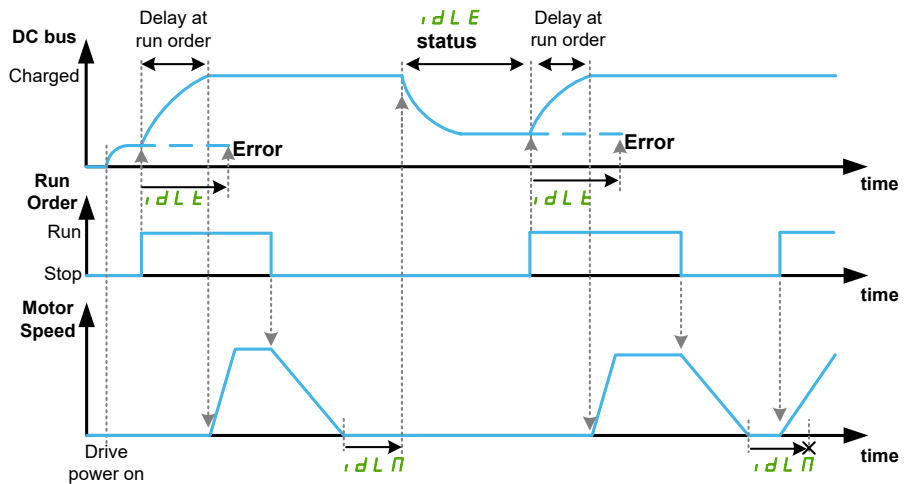

- **Manual mode: [Energy Saving Assign] IDLE** assigned,
 - At drive power on, the function is not active: the DC bus charges.
 - At rising edge of the assigned input, the energy saving mode is active if the motor is stopped and if there is no run command active,
 - At falling edge, the energy saving is deactivated, the drive switches to normal operation. If a run command is requested long enough after the energy saving deactivation, the DC bus is charged: there is no delay applied on the run command. It can be used to anticipate a run command.

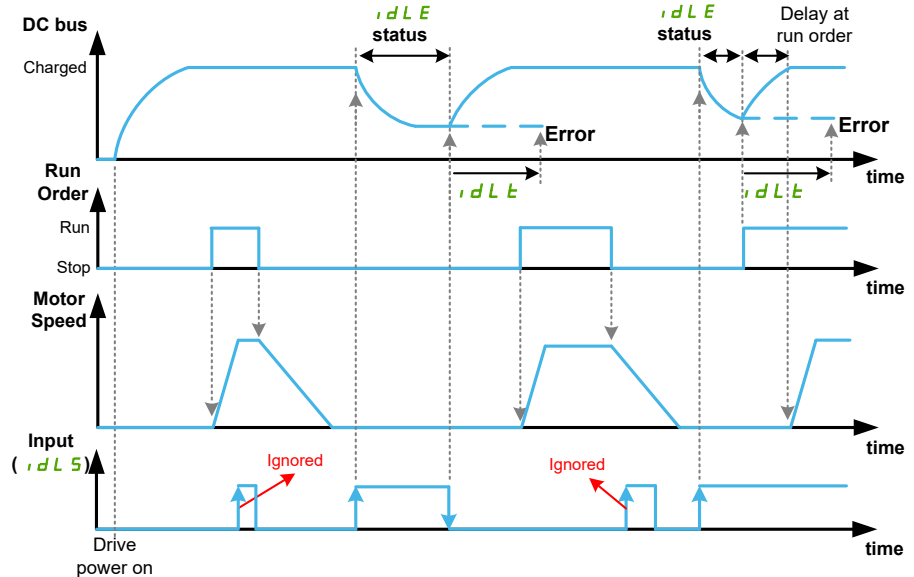

- **Semi-automatic mode: [Energy Saving Delay] IDLE** configured and **[Energy Saving Assign] IDLE** assigned,
 - At drive power on, the function is active: DC bus is not charged.
 - After the motor is stopped, the energy saving mode is active after **[Energy Saving Delay] IDLE**
 - NOTE: if a run command is requested during **[Energy Saving Delay] IDLE**, the DC bus is still charged: there is no delay applied on the run command.
 - During **[Energy Saving Delay] IDLE**, a rising edge of the assigned input activates precociously the energy saving mode,
 - When the energy saving mode is active, a falling edge of the assigned input deactivates the energy saving mode: the drive switches to normal operation.
 - NOTE: During **[Energy Saving Delay] IDLE**, the drive is not in energy saving mode: a falling edge has no impact. The drive still switches in energy saving mode at the end of the delay.

[Energy Saving Delay] IDLE

Delay before Energy Saving.

Wait time before going to energy saving mode after motor is stopped.

At drive power on, if **[Energy Saving Delay] IDLE** is configured, the DC bus is not charged: the drive goes directly to **[Energy Saving] IDLE**.

This parameter is forced to **[No] NO** if **[Mains contactor command] L L C** - function is enabled (i.e. **[Mains Contactor] L L C** is assigned to an output).

Setting	Code / Value	Description
[No]	no	Function deactivated. Factory setting (1)
0...32,400 s		Setting range
(1): On ATV•80 and ATV•B0, the factory setting value is 60 s.		

[Energy Saving Assign] , d L 5

Energy saving input assignment.

At rising edge, the drive switches to energy saving state if the motor is stopped without run command active.

A falling edge switch the drive to normal operation.

This parameter is forced to **[Not assigned] NO** if **[Mains contactor command] L L C** - function is enabled (i.e. **[Mains Contactor] L L C** is assigned to an output).

Setting	Code / Value	Description
[Not Assigned]	no	Not assigned Factory setting
[DI1]...[DIx]	L , I...L , X	Digital input DI1...DIx used at high level.
[DI11]...[DI16]	L , I I... L , I 6	Digital input DI11...DI16 on high level if Extended I/O module VW3A3203 has been inserted.
[CD01]... [CD15]	C d 0 1... C d 1 5	Virtual digital input CMD.01...CMD.15 (command bit 1 to 15). NOTE: CD01...CD10 are only available in [I/O Profile] , o configuration.
[C101]... [C115]	C 1 0 1... C 1 1 5	Virtual digital input CMD1.01...CMD1.15 with integrated Modbus Serial (command bit 1 to 15). NOTE: C101...C110 are only available in [I/O Profile] , o configuration.
[C201]... [C215]	C 2 0 1... C 2 1 5	Virtual digital input CMD2.01...CMD2.15 with CANopen® fieldbus module (command bit 1 to 15). NOTE: C201...C210 are only available in [I/O profile] , o configuration.
[C301]... [C315]	C 3 0 1... C 3 1 5	Virtual digital input CMD3.01...CMD3.15 with fieldbus module such as PROFIBUS dp V1 or Ethernet Option Module (command bit 1 to 15). NOTE: C301...C310 are only available in [I/O profile] , o configuration
[C501]... [C515]	C 5 0 1... C 5 1 5	Virtual digital input CMD5.01...CMD5.15 with embedded Ethernet (command bit 1 to 15) NOTE: C501...C510 are only available in [I/O profile] , o configuration

[Egy Saving Timeout] , d L E

Energy Saving Timeout.

If the value of the parameter **[Egy Saving Timeout] , d L E** is increased, the run command can be delayed for the amount of time set by the parameter **[Egy Saving Timeout] , d L E** as long as the condition to leave **[Energy Saving] , d L E** state is not fulfilled (for example, but not limited to, undervoltage or overvoltage of the supply mains).

▲ WARNING**UNANTICIPATED EQUIPMENT OPERATION**

Verify that the modification of the setting of this parameter does not result in unsafe conditions.

Failure to follow these instructions can result in death, serious injury, or equipment damage.

After **[Egy Saving Timeout] , d L E** time, if the drive is still in **[Energy Saving] , d L E** mode, the error **[Egy Saving Exit Error] , d L F** is triggered

Setting	Description
1...999 s	Setting range Factory setting: 5 s ⁽¹⁾
(1): On ATV•80 and ATV•B0, the factory setting value is 8 s.	

[QR code]

[QR code] ПУР - Menu

Access

[My preferences] → [QR code]

About This Menu

This menu can only be accessed with the Graphic Display Terminal.

It gives access to 5 QR Codes:

- **[QR Code] ПУР** : scanning this QR code brings to a landing page on Internet with the information on the Technical product datasheet and a link for Schneider Electric App available for services.
- **[My link 1] ПУР 1 -** to **[My link 4] ПУР 4 -** : 4 QR codes customized with the commissioning software. By default, scanning these QR codes brings to the same landing page as **[QR Code] ПУР** . To customize these QR codes with SoMove, go to “**Device > HMI Personalization > QR codes**”.

NOTE: The name “My link x” can also be changed during the customization.

[Pairing password]

[Pairing password] P P ,

Access

[My preferences] → [Pairing password]

About This Menu

This function can only be accessed in Expert mode. This function is used to detect whenever an option module has been replaced or the software has been modified in any way. When a pairing password is entered, the parameters of the option modules currently inserted are stored. On every subsequent power-up, these parameters are verified and, in the event of a discrepancy, the drive locks in **[Boards Compatibility] H C F**. Before the drive can be restarted, it is necessary to revert to the original situation or reenter the pairing password.

The following parameters are verified:

- The type of option modules.
- The software version of the drive and the option modules.
- The serial number for the control block boards.

[Pairing password] P P ,

Operation as a pair password.

Setting	Description
[OFF] 0 F F ...9,999	Setting range Factory setting: 0 F F

The **[OFF] 0 F F** value signifies that the pairing password function is inactive.

The **[ON] 0 n** value signifies that the pairing password function is active and that a password is required to start the drive in the event of a **[Boards Compatibility] H C F** detected error.

As soon as the password has been entered, the drive is unlocked and the code changes to **[ON] 0 n**.

Maintenance

Limitation of Warranty

The warranty does not apply if the product has been opened, except by Schneider Electric services.

Servicing

⚡⚠ DANGER

HAZARD OF ELECTRIC SHOCK, EXPLOSION OR ARC FLASH

Read and understand the instructions in **Safety Information** chapter before performing any procedure in this chapter.

Failure to follow these instructions will result in death or serious injury.

The temperature of the products described in this manual may exceed 80 °C (176 °F) during operation.

⚠ WARNING

HOT SURFACES

- Ensure that any contact with hot surfaces is avoided.
- Do not allow flammable or heat-sensitive parts in the immediate vicinity of hot surfaces.
- Verify that the product has sufficiently cooled down before handling it.
- Verify that the heat dissipation is sufficient by performing a test run under maximum load conditions.

Failure to follow these instructions can result in death, serious injury, or equipment damage.

⚠ WARNING

INSUFFICIENT MAINTENANCE

Verify that the maintenance activities described below are performed at the specified intervals.

Failure to follow these instructions can result in death, serious injury, or equipment damage.

Adherence to the environmental conditions must be ensured during operation of the drive. In addition, during maintenance, verify and, if appropriate, correct all factors that may have an impact on the environmental conditions.

	Part concerned	Activity	Interval (1)
Overall condition	All parts such as housing, HMI, control block, connections, etc.	Perform a visual inspection	At least every year
Corrosion	Terminals, connectors, screws, EMC plate	Inspect and clean if required	
Dust	Terminals, fans, enclosures air inlets and air outlets, air filters of cabinet	Inspect and clean if required	
	Floor standing drives filter mats	Inspect	At least every year
		Change	At least every 4 years
Cooling	Wall mounting drives fan	Verify the fan operation	At least every year

	Part concerned	Activity	Interval (1)
		Replace the fan, see catalog and the instructions sheets on www.schneider-electric.com .	After 3 to 5 years, depending on the operating conditions
	Floor standing drives fan for power part and enclosure door fan	Replace the fans, see catalog and the instructions sheets on www.schneider-electric.com .	Every 35000 operating hours or every 6 years
Fastening	All screws for electrical and mechanical connections	Verify tightening torques	At least every year

(1) Maximum maintenance intervals from the date of commissioning. Reduce the intervals between maintenance to adapt maintenance to the environmental conditions, the operating conditions of the drive, and to any other factor that may influence the operation and/ or maintenance requirements of the drive.

Spares and Repairs

Serviceable product. Please contact your Customer Care Center on:

www.se.com/CCC.

Long Time Storage

If the drive was not connected to mains for an extended period of time, the capacitors must be restored to their full performance before the motor is started.

NOTICE

REDUCED CAPACITOR PERFORMANCE

- Apply mains voltage to the drive for one hour before starting the motor if the drive has not been connected to mains for the specified periods of time.(1)
- Verify that no Run command can be applied before the period of one hour has elapsed.
- Verify the date of manufacture if the drive is commissioned for the first time and run the specified procedure if the date of manufacture is more than 12 months in the past.

Failure to follow these instructions can result in equipment damage.

(1) Period of time:

- 12 months at a maximum storage temperature of +50°C (+122°F)
- 24 months at a maximum storage temperature of +45°C (+113°F)
- 36 months at a maximum storage temperature of +40°C (+104°F)

If the specified procedure cannot be performed without a Run command because of internal mains contactor control, perform this procedure with the power stage enabled, but the motor being at a standstill so that there is no appreciable mains current in the capacitors.

Fan Replacement

It is possible to order a new fan for the drive maintenance, see the catalog numbers on www.se.com.

Customer Care Center

For additional support, you can contact our Customer Care Center on:

www.se.com/CCC.

Diagnostics and Troubleshooting

What's in This Part

Warning Codes	620
Error Codes	623

Overview

This chapter describes the various types of diagnostics and provides troubleshooting assistance.

DANGER

HAZARD OF ELECTRIC SHOCK, EXPLOSION OR ARC FLASH

Read and understand the instructions in **Safety Information** chapter before performing any procedure in this chapter.

Failure to follow these instructions will result in death or serious injury.

Warning Codes

List of Available Warnings Messages

Setting	Code	Description
[No Warning stored]	<i>n o R</i>	No warning stored
[Fallback Frequency]	<i>F r F</i>	Reaction on event: Fallback frequency
[Speed Maintained]	<i>r L S</i>	Reaction on event: Speed maintained
[Type of stop]	<i>S t t</i>	Reaction on event: Stop following [Type of stop] <i>S t t</i> without triggering an error
[Ref Frequency Warning]	<i>S r R</i>	Frequency reference reached
[Life Cycle Warn 1]	<i>L C R 1</i>	Life cycle warning 1
[Life Cycle Warn 2]	<i>L C R 2</i>	Life cycle warning 2
[Dry Run Warning]	<i>d r Y R</i>	Dry run warning , page 399
[LowFlow Warning]	<i>L F R</i>	Low flow warning , page 403
[High Flow Warning]	<i>H F P R</i>	High flow warning , page 420
[InPres Warning]	<i>, P P R</i>	Inlet pressure monitoring warning , page 410
[Low OutPres Warn]	<i>o P L R</i>	Low outlet pressure warning , page 415
[High OutPres Warn]	<i>o P H R</i>	High outlet pressure warning , page 415
[PumpCycle warning]	<i>P C P R</i>	Pumpcycle monitoring warning , page 389
[Anti-Jam Warning]	<i>J A N R</i>	Anti-jam warning , page 392
[Pump Low Flow]	<i>P L F R</i>	Pump low flow warning , page 403
[LowPres Warning]	<i>L P R</i>	Low pressure warning
[Flow Limit activated]	<i>F S R</i>	Flow limitation function is active , page 379
[PID error Warning]	<i>P E E</i>	PID error warning , page 325
[PID Feedback Warn]	<i>P F R</i>	PID feedback warning , page 317
[PID High Fdbck Warn]	<i>P F R H</i>	PID feedback high threshold reached , page 317
[PID Low Fdbck Warn]	<i>P F R L</i>	PID feedback low threshold reached , page 317
[Regulation Warning]	<i>P , S H</i>	PID feedback monitoring warning , page 343
[AI2 Th Warning]	<i>t P 2 R</i>	AI2 Thermal warning , page 165
[AI3 Th Warning]	<i>t P 3 R</i>	AI3 Thermal warning , page 165
[AI4 Th Warning]	<i>t P 4 R</i>	AI4 Thermal warning , page 165
[AI5 Th Warning]	<i>t P 5 R</i>	AI5 Thermal warning , page 165
[AI1 4-20 Loss Warning]	<i>R P 1</i>	AI1 4-20 mA loss warning
[AI2 4-20 Loss Warning]	<i>R P 2</i>	AI2 4-20 mA loss warning
[AI3 4-20 Loss Warning]	<i>R P 3</i>	AI3 4-20 mA loss warning
[AI4 4-20 Loss Warning]	<i>R P 4</i>	AI4 4-20 mA loss warning
[AI5 4-20 Loss Warning]	<i>R P 5</i>	AI5 4-20 mA loss warning
[Drive Thermal Warning]	<i>t H R</i>	Drive overheating warning
[IGBT Thermal Warning]	<i>t J R</i>	IGBT thermal state warning
[Fan Counter Warning]	<i>F C t R</i>	Fan counter speed warning , page 574
[Fan Feedback Warning]	<i>F F d R</i>	Fan feedback warning , page 574
[Ext. Error Warning]	<i>E F R</i>	External error warning , page 539
[Undervoltage Warning]	<i>u S R</i>	Undervoltage warning

Setting	Code	Description
[Preventive UnderV Active]	<i>u P R</i>	Controlled stop threshold is reached
[Forced Run]	<i>E r n</i>	Drive in forced run
[Mot Freq High Thd]	<i>F t R</i>	Motor frequency high threshold 1 reached , page 457
[Mot Freq Low Thd]	<i>F t R L</i>	Motor frequency low threshold 1 reached , page 457
[Mot Freq Low Thd 2]	<i>F t R L 2</i>	Motor frequency low threshold 2 reached , page 457
[High Speed Reached]	<i>F L R</i>	High speed reached warning
[Ref Freq High Thd reached]	<i>r t R H</i>	Reference frequency high threshold reached , page 458
[Ref Freq Low Thd reached]	<i>r t R L</i>	Reference frequency low threshold reached , page 458
[2nd Freq Thd Reached]	<i>F t R 2</i>	Motor frequency high threshold 2 reached , page 458
[Current Thd Reached]	<i>C t R</i>	Motor current high threshold reached , page 457
[Low Current Reached]	<i>C t R L</i>	Motor current low threshold reached , page 457
[High Torque Warning]	<i>t t H R</i>	High torque threshold reached , page 458
[Low Torque Warning]	<i>t t L R</i>	Low torque threshold reached , page 459
[Process Undld Warn]	<i>u L R</i>	Process underload warning , page 479
[Process Overload Warning]	<i>o L R</i>	Overload warning , page 482
[Drv Therm Thd reached]	<i>t R d</i>	Drive thermal threshold reached
[Motor Therm Thd reached]	<i>t S R</i>	Motor thermal threshold reached , page 458
[Power High Threshold]	<i>P t H R</i>	Power high threshold reached , page 84
[Power Low Threshold]	<i>P t H L</i>	Power low threshold reached , page 84
[Cust Warning 1]	<i>C R S 1</i>	Customer warning 1 active , page 571
[Cust Warning 2]	<i>C R S 2</i>	Customer warning 2 active , page 572
[Cust Warning 3]	<i>C R S 3</i>	Customer warning 3 active
[Cust Warning 4]	<i>C R S 4</i>	Customer warning 4 active
[Cust Warning 5]	<i>C R S 5</i>	Customer warning 5 active
[AFE Mains Undervoltage]	<i>u r R</i>	AFE mains undervoltage
[Power Cons Warning]	<i>P o W d</i>	Power consumption warning
[Switch OutPres Warn]	<i>o P S R</i>	Outlet pressure high switch warning , page 415
[MP Capacity Warn]	<i>MP C R</i>	Multipump available capacity warning , page 254
[Lead Pump Warn]	<i>MP L R</i>	Lead pump not available warning , page 254
[High Level Warning]	<i>L L H R</i>	High level warning , page 289
[Low Level Warning]	<i>L L L R</i>	Low level warning , page 289
[Level Switch Warning]	<i>L L W R</i>	Level switch warning , page 289
[MonitorCircuit A Warn]	<i>i W R</i>	Monitoring circuit A warning
[MonitorCircuit B Warn]	<i>i W b</i>	Monitoring circuit B warning
[MonitorCircuit C Warn]	<i>i W C</i>	Monitoring circuit C warning
[MonitorCircuit D Warn]	<i>i W d</i>	Monitoring circuit D warning
[CabinetCircuit A Warn]	<i>C W R</i>	Cabinet circuit A warning , page 576
[CabinetCircuit B Warn]	<i>C W b</i>	Cabinet circuit B warning , page 577
[CabinetCircuit C Warn]	<i>C W C</i>	Cabinet circuit C warning , page 577
[MotorWinding A Warn]	<i>t W R</i>	Motor winding A warning , page 579
[MotorWinding B Warn]	<i>t W b</i>	Motor winding B warning , page 580
[MotorBearing A Warn]	<i>t W C</i>	Motor bearing A warning , page 580

Setting	Code	Description
[MotorBearing B Warn]	<i>t W d</i>	Motor bearing B warning , page 582
[Circuit Breaker Warn]	<i>C b W</i>	Circuit breaker warning , page 583
[Cab I/O 24V Warn]	<i>P 2 4 C</i>	Cabinet I/O 24V missing warning
[AFE Motor Limitation]	<i>C L , n</i>	AFE motor limitation , page 478
[AFE Generator Limitation]	<i>C L , G</i>	AFE regen limitation , page 478
[AFE Sensor thermal state]	<i>t H S R</i>	AFE thermal state warning
[AFE IGBT thermal state]	<i>t H J R</i>	AFE IGBT thermal warning
[Cabinet Fan Fdbck Warn]	<i>F F C R</i>	Cabinet fan feedback warning , page 574
[Cabinet Fan Counter Warn]	<i>F C C R</i>	Cabinet fan counter warning , page 574
[Cabinet Overheat Warn]	<i>C H R</i>	Cabinet overheat warning , page 565
[CMI Jumper Warn]	<i>C n , J</i>	CMI jumper warning
[AFE Fan Counter Warn]	<i>F C b R</i>	AFE fan counter warning , page 574
[AFE Fan Fdbck Warn]	<i>F F b R</i>	AFE fan feedback warning , page 574
[M/P Device Warn]	<i>n P d R</i>	Multipump device warning , page 254
[Temp Sens AI2 Warn]	<i>t S 2 R</i>	Temperature sensor AI2 warning (open circuit)
[Temp Sens AI3 Warn]	<i>t S 3 R</i>	Temperature sensor AI3 warning (open circuit)
[Temp Sens AI4 Warn]	<i>t S 4 R</i>	Temperature sensor AI4 warning (open circuit)
[Temp Sens AI5 Warn]	<i>t S 5 R</i>	Temperature sensor AI5 warning (open circuit)
[DC Bus Ripple Warn]	<i>d C r W</i>	DC Bus Ripple Warning
[Ethernet Internal Warning]	<i>i n W n</i>	Ethernet Internal Warning
[VxCtrl Warning]	<i>V C R</i>	Vortex control warning
[Cooling Pump Warn]	<i>C o P R</i>	Cooling pump warning resulting from the detection of an error during pump operation or resulting from [Pump diagnostics] C P E (related to ATV9L0).
[Module Overheat]	<i>n o R</i>	Module overheating warning resulting from the ambient temperature monitoring
[Fallback Channel]	<i>R F F L</i>	Automatic fallback behavior activated after a fieldbus communication interruption , page 556
[ON Lock Warning]	<i>L K o n</i>	ON lock warning resulting from an external device not ready.
[Internal Error 22]	<i>i n F n</i>	Internal error 22 (Embedded Ethernet)
[Modbus Com Inter.]	<i>S L F I</i>	Modbus communication interruption warning

Error Codes

What's in This Chapter

Overview	625
[AFE DC-Caps Error] <i>R C F 1</i>	627
[AFE Current Control Error] <i>R C F 2</i>	627
[AFE Line Filter Error] <i>R C F 3</i>	628
[Adv. Function Lock] <i>R F L F</i>	628
[Angle error] <i>R 5 F</i>	629
[Circuit Breaker Error] <i>C b F</i>	629
[CabinetCircuit A Error] <i>C F A</i>	630
[CabinetCircuit B Error] <i>C F b</i>	630
[CabinetCircuit C Error] <i>C F C</i>	631
[Incorrect Configuration] <i>C F F</i>	631
[Invalid Configuration] <i>C F ,</i>	632
[Conf Transfer Error] <i>C F , 2</i>	632
[Pre-settings Transfer Error] <i>C F , 3</i>	633
[Cabinet Overheat Error] <i>C H F</i>	633
[Fieldbus Com Interrupt] <i>C n F</i>	634
[CANopen Com Interrupt] <i>C o F</i>	634
[Cooling Pump Error] <i>C o P F</i>	635
[Precharge Capacitor] <i>C r F 1</i>	635
[AFE contactor fdbk error] <i>C r F 3</i>	636
[Channel Switch Error] <i>C 5 F</i>	637
[DC Bus Ripple Error] <i>d C r E</i>	637
[Dry Run Error] <i>d r Y F</i>	638
[EEPROM Control] <i>E E F 1</i>	638
[EEPROM Power] <i>E E F 2</i>	639
[External Error] <i>E P F 1</i>	639
[Fieldbus Error] <i>E P F 2</i>	640
[Embd Eth Com Interrupt] <i>E t H F</i>	640
[Out Contact Closed Error] <i>F C F 1</i>	641
[Out Contact Opened Error] <i>F C F 2</i>	641
[FDR 1 Error] <i>F d r 1</i>	642
[FDR 2 Error] <i>F d r 2</i>	643
[Fan Feedback Error] <i>F F d F</i>	644
[Firmware Update Error] <i>F w E r</i>	644
[Boards Compatibility] <i>H C F</i>	645
[High Flow Error] <i>H F P F</i>	645
[Egy Saving Exit Error] <i>, d L F</i>	646
[MonitorCircuit A Error] <i>, F A</i>	646
[MonitorCircuit B Error] <i>, F b</i>	647
[MonitorCircuit C Error] <i>, F C</i>	647
[MonitorCircuit D Error] <i>, F d</i>	648
[Input Overheating] <i>, H F</i>	648
[Internal Link Error] <i>, L F</i>	649
[Internal Error 0] <i>, n F 0</i>	649
[Internal Error 1] <i>, n F 1</i>	650
[Internal Error 2] <i>, n F 2</i>	650
[Internal Error 3] <i>, n F 3</i>	651
[Internal Error 4] <i>, n F 4</i>	651
[Internal Error 6] <i>, n F 6</i>	652
[Internal Error 7] <i>, n F 7</i>	652
[Internal Error 8] <i>, n F 8</i>	653
[Internal Error 9] <i>, n F 9</i>	653
[Internal Error 10] <i>, n F A</i>	654
[Internal Error 11] <i>, n F b</i>	654
[Internal Error 12] <i>, n F C</i>	655
[Internal Error 13] <i>, n F d</i>	655
[Internal Error 14] <i>, n F E</i>	656
[Internal Error 15] <i>, n F F</i>	656
[Internal Error 16] <i>, n F G</i>	657
[Internal Error 17] <i>, n F H</i>	657
[Internal Error 20] <i>, n F K</i>	658
[Internal Error 21] <i>, n F L</i>	658
[Internal Error 22] <i>, n F n</i>	659

[Internal Error 23]	<i>i n F n</i>	659
[Internal Error 25]	<i>i n F P</i>	660
[Internal Error 27]	<i>i n F r</i>	660
[Internal Error 28]	<i>i n F S</i>	661
[Internal Error 29]	<i>i n F t</i>	661
[Internal Error 30]	<i>i n F u</i>	662
[Internal Error 31]	<i>i n F V</i>	662
[Inlet Pressure Error]	<i>i P P F</i>	663
[Anti Jam Error]	<i>J A n F</i>	663
[Input Contactor]	<i>L C F</i>	664
[High Level Error]	<i>L C H F</i>	664
[Low Level Error]	<i>L C L F</i>	665
[AI1 4-20mA loss]	<i>L F F 1</i>	665
[AI2 4-20mA loss]	<i>L F F 2</i>	666
[AI3 4-20mA loss]	<i>L F F 3</i>	666
[AI4 4-20mA loss]	<i>L F F 4</i>	667
[AI5 4-20mA loss]	<i>L F F 5</i>	667
[ON Lock Error]	<i>L K o n</i>	668
[MultiDrive Link Error]	<i>n d L F</i>	668
[Mains Freq Out Of Range]	<i>n F F</i>	669
[Module Overheat]	<i>n o F</i>	669
[M/P Device Error]	<i>n P d F</i>	670
[Lead Pump Error]	<i>n P L F</i>	671
[DC Bus Overvoltage]	<i>o b F</i>	671
[AFE Bus unbalancing]	<i>o b F 2</i>	672
[Overcurrent]	<i>o C F</i>	672
[Drive Overheating]	<i>o H F</i>	673
[Process Overload]	<i>o L C</i>	673
[Motor Overload]	<i>o L F</i>	674
[Single Output Phase Loss]	<i>o P F 1</i>	674
[Output Phase Loss]	<i>o P F 2</i>	675
[Out Pressure High]	<i>o P H F</i>	676
[Out Pressure Low]	<i>o P L F</i>	677
[Supply Mains Overvoltage]	<i>o S F</i>	677
[Cab I/O 24V Error]	<i>P 2 4 C</i>	678
[PumpCycle Start Error]	<i>P C P F</i>	678
[PID Feedback Error]	<i>P F n F</i>	679
[Program Loading Error]	<i>P G L F</i>	679
[Program Running Error]	<i>P G r F</i>	680
[Input phase loss]	<i>P H F</i>	680
[Pump Low Flow Error]	<i>P L F F</i>	681
[Safety Function Error]	<i>S A F F</i>	681
[Motor short circuit]	<i>S C F 1</i>	682
[Ground Short Circuit]	<i>S C F 3</i>	682
[IGBT Short Circuit]	<i>S C F 4</i>	683
[Motor Short Circuit]	<i>S C F 5</i>	683
[AFE ShortCircuit error]	<i>S C F 6</i>	684
[Modbus Com Interruption]	<i>S L F 1</i>	684
[PC Com Interruption]	<i>S L F 2</i>	685
[HMI Com Interruption]	<i>S L F 3</i>	685
[Motor Overspeed]	<i>S o F</i>	686
[Security Files Corrupt]	<i>S P F C</i>	686
[Motor Stall Error]	<i>S t F</i>	687
[AI2 Thermal Sensor Error]	<i>t 2 C F</i>	688
[AI3 Thermal Sensor Error]	<i>t 3 C F</i>	689
[AI4 Thermal Sensor Error]	<i>t 4 C F</i>	690
[AI5 Thermal Sensor Error]	<i>t 5 C F</i>	691
[MotorWinding A Error]	<i>t F A</i>	691
[MotorWinding B Error]	<i>t F b</i>	692
[MotorBearing A Error]	<i>t F C</i>	692
[MotorBearing B Error]	<i>t F d</i>	693
[AI2 Th Level Error]	<i>t H 2 F</i>	693
[AI3 Th Level Error]	<i>t H 3 F</i>	694
[AI4 Th Level Error]	<i>t H 4 F</i>	694
[AI5 Th Level Error]	<i>t H 5 F</i>	695
[IGBT Overheating]	<i>t J F</i>	695
[AFE IGBT over-heat error]	<i>t J F 2</i>	696
[Autotuning Error]	<i>t n F</i>	696

[Process Underload] $\mu L F$	697
[AFE Mains Undervoltage] $\mu r F$	697
[Supply Mains UnderV] $\mu 5 F$	698
[VxCtrl Error] $V c F$	698

Overview

Clearing the Detected Error

This table presents the steps to follow if intervention on the drive system is required:

Step	Action
1	Disconnect all power, including external control power that may be present.
2	Lock all power disconnects in the open position.
3	Wait 15 minutes to allow the DC bus capacitors to discharge (the drive LEDs are not indicators of the absence of DC bus voltage).
4	Measure the voltage of the DC bus between the PA/+ and PC/- terminals to ensure that the voltage is less than 42 Vdc.
5	If the DC bus capacitors do not discharge completely, contact your local Schneider Electric representative. Do not repair or operate the drive.
6	Find and correct the cause of the detected error.
7	Restore power to the drive to confirm that the detected error has been rectified.

After the cause has been removed, the detected error can be cleared by:

- Switching off the drive.
- Using the **[Product Restart]** $r P$ parameter.
- Using the digital input or the control bit assigned to **[Prod Restart Assign]** $r P R$.
- Using the **[Auto Fault Reset]** $R E r$ - function.
- A digital input or control bit set to the **[Fault reset]** $r 5 E$ - function.
 - For **[Fault Reset Assign]** $r 5 F$ and **[Extended Fault Reset]** $H r C F$ refer to **[Fault reset]** $r 5 E$ - Menu.
- Pressing the **STOP/RESET** key on the Graphic Display Terminal depending on the setting of **[Stop Key Enable]** $P 5 E$.

How To Clear the Error Code?

The following table summarizes the possibilities to clear a detected error after the cause has been removed:

How to clear the error code after the cause has been removed	List of the cleared error
<ul style="list-style-type: none"> • Switch off the drive. • Use the [Product Restart] $r P$ parameter. • Use the digital input or the control bit assigned to [Prod Restart Assign] $r P R$. 	All detected error.
<ul style="list-style-type: none"> • As soon as its cause has been removed. 	CFF, CFI, CF12, CF13, CSF, FWER, HCF, PGLF, PHF, URF, USF
<ul style="list-style-type: none"> • Use the digital input or the control bit assigned to [Fault Reset Assign] $r 5 F$. 	ACF1, ACF2, ACF3, ASF, MFF, SOF, TNF

How to clear the error code after the cause has been removed	List of the cleared error
<ul style="list-style-type: none"> Pressing the RESET button on the HMI panel 	
<ul style="list-style-type: none"> Use the digital input or the control bit assigned to [Fault Reset Assign] <i>r 5 F</i>. Pressing the RESET button on the HMI panel Use the [Auto Fault Reset] <i>A E r -</i> function. 	CFA, CFB, CFC, CHF, CNF, COF, COPF, DRYF, EPF1, EPF2, ETHF, FCF2, FDR1, FDR2, FFDF, HFPF, IDLF, IFA, IFB, IFC, IFD, IHF, INF9, INFB, INFV, IPPF, JAMF, LCF, LCHF, LCLF, LFF1, LFF2, LFF3, LFF4, LFF5, LKON, MDLF, MOF, MPDF, MPLF, OBF, OBF2, OHF, OLC, OLF, OPF1, OPF2, OPHF, OPLF, OSF, P24C, PCPF, PFMF, PLFF, SCF4, SCF5, SLF1, SLF2, SLF3, STF, T2CF, T3CF, T4CF, T5CF, TFA, TFB, TFC, TFD, TH2F, TH3F, TH4F, TH5F, TJF, TJF2, ULF
If [Fault Reset Assign] <i>H r F L</i> is set to <i>Y E S</i> : <ul style="list-style-type: none"> Use the digital input or the control bit assigned to [Fault Reset Assign] <i>r 5 F</i>, Press the STOP/RESET key on the Graphic Display Terminal depending on the setting of [Stop Key Enable] <i>P 5 E</i>. 	CRF1, INFD, SCF1

[AFE DC-Caps Error] *A C F 1*



Probable Cause

AFE DC-capacitors error: DC-capacitors overcurrent.

- Low mains voltage for too long.
- Mains voltage is on a low limit, the modulation rate of the AFE increases to help protect the DC link capacitors the **[AFE DC-Caps Error] *A C F 1*** is triggered.



Remedy

- Verify mains voltage.
- Verify parameter setting for mains voltage.



Clearing the Error Code

This detected error can be cleared manually with the **[Fault Reset Assign] *r 5 F*** parameter after its cause has been removed.

[AFE Current Control Error] *A C F 2*



Probable Cause

Mains voltage interruption.



Remedy

- Verify mains voltage.
- Reduce number of voltage drop-downs.



Clearing the Error Code

This detected error can be cleared manually with the **[Fault Reset Assign] *r 5 F*** parameter after its cause has been removed.

[AFE Line Filter Error] *A L F 3*



Probable Cause

Mains voltage drops during generator operation.



Remedy

Verify mains voltage.



Clearing the Error Code

This detected error can be cleared manually with the **[Fault Reset Assign]** *r 5 F* parameter after its cause has been removed.

[Adv. Function Lock] *A F L F*



Probable Cause

[LevelCtrl Strategy] *L C S L* is set to **[Energy Optimized]** *A d V* and a run order is given.



Remedy

Contact your local Schneider Electric representative.



Clearing the Error Code

This detected error can be cleared manually with the **[Fault Reset Assign]** *r 5 F* parameter after its cause has been removed.

[Angle error] *A S F*



Probable Cause

This error is triggered during the phase-shift angle measurement if the motor phase is disconnected or if the motor inductance is too high.



Remedy

- Verify the motor phases and the maximum current allowed by the drive.



Clearing the Error Code

This detected error can be cleared manually with the **[Fault Reset Assign] *r 5 F*** parameter after its cause has been removed.

[Circuit Breaker Error] *L b F*



Probable Cause

The DC bus voltage level is not correct compared to the circuit breaker logic control (start or stop pulse) after the configured timeout **[Mains V. time out] *L C E***.



Remedy

- Verify the circuit breaker logic control (pulse time for start and stop).
- Verify the mechanical state of the circuit breaker.



Clearing the Error Code

This detected error requires a power reset.

[CabinetCircuit A Error] *C F A*



Probable Cause

The monitoring function has detected an error. The digital input assigned to **[CabinetCircuit A Assign] *C F A A*** is active when the detected error duration is longer than **[CabinetCircuit A Delay] *F d A***.



Remedy

- Identify the cause of detection.
- Verify the connected device (door switch, thermal switch,...) and its wiring.
- Verify the **[CabinetCircuit A Assign] *C F A A*** parameter assignment.



Clearing the Error Code

This detected error can be cleared with the **[Auto Fault Reset] *A E r*** or manually with the **[Fault Reset Assign] *r S F*** parameter after its cause has been removed.

[CabinetCircuit B Error] *C F B*



Probable Cause

The monitoring function has detected an error. The digital input assigned to **[CabinetCircuit B Assign] *C F B B*** is active when the detected error duration is longer than **[CabinetCircuit B Delay] *F d B***.



Remedy

- Identify the cause of detection.
- Verify the connected device (door switch, thermal switch,...) and its wiring.
- Verify the **[CabinetCircuit B Assign] *C F B B*** parameter assignment.



Clearing the Error Code

This detected error can be cleared with the **[Auto Fault Reset] *A E r*** or manually with the **[Fault Reset Assign] *r S F*** parameter after its cause has been removed.

[CabinetCircuit C Error] *L F L*



Probable Cause

The monitoring function has detected an error. The digital input assigned to **[CabinetCircuit C Assign] *L F H L*** is active when the detected error duration is longer than **[CabinetCircuit C Delay] *F d L***.



Remedy

- Identify the cause of detection.
- Verify the connected device (door switch, thermal switch,...) and its wiring.
- Verify the **[CabinetCircuit C Assign] *L F H L*** parameter assignment.



Clearing the Error Code

This detected error can be cleared with the **[Auto Fault Reset] *H L r*** or manually with the **[Fault Reset Assign] *r 5 F*** parameter after its cause has been removed.

[Incorrect Configuration] *L F F*



Probable Cause

- Option module changed or removed .
- Control board replaced by a control board configured on a drive with a different rating.
- The current configuration is inconsistent.



Remedy

- Verify that there is no detected error on the option module.
- In the event of the control block being changed deliberately, see the remarks below.
- Return to factory settings or retrieve the backup configuration if it is valid.



Clearing the Error Code

This detected error is cleared as soon as its cause has been removed.

[Invalid Configuration] [F ,]



Probable Cause

Invalid configuration.

The configuration loaded in the drive via the commissioning tool or fieldbus is inconsistent.



Remedy

- Verify the loaded configuration.
- Load a valid configuration.



Clearing the Error Code

This detected error is cleared as soon as its cause has been removed.

[Conf Transfer Error] [F , 2]



Probable Cause

- The configuration transfer to the drive was not successful or interrupted.
- The configuration loaded is not compatible with the drive.



Remedy

- Verify the configuration loaded previously.
- Load a compatible configuration.
- Use PC software commissioning tool to transfer a compatible configuration
- Perform a factory setting



Clearing the Error Code

This detected error is cleared as soon as its cause has been removed.

[Pre-settings Transfer Error] $\llcorner F \ , \exists$



Probable Cause

The configuration transfer to the drive was not successful or interrupted.



Remedy

Contact your local Schneider Electric representative.



Clearing the Error Code

This detected error is cleared as soon as its cause has been removed.

[Cabinet Overheat Error] $\llcorner H F$



Probable Cause

The cabinet thermal switch is at active state, the cabinet fan(s) has been switched on but there is no fan feedback.

The digital inputs DI50 and DI51 of drives equipped with Cabinet IO are configured as cabinet temperature monitoring. If the enclosure thermo switch opens in case of over temperature, the **[Cabinet Overheat Error]** $\llcorner H F$ is triggered.

This error can be triggered only in RUN state. On other state, the **[Cabinet Overheat Warn]** $\llcorner H A$ is active.



Remedy

- Verify cabinet fan(s) and its wiring.
- Verify the temperature in the enclosure is not too high.
- Verify the setting of the thermoswitch (must be 60°C (140°F))



Clearing the Error Code

This detected error can be cleared with the **[Auto Fault Reset]** $\# E r$ or manually with the **[Fault Reset Assign]** $r 5 F$ parameter after its cause has been removed.

[Fieldbus Com Interrupt] $\square \square F$



Probable Cause

Communication interruption on fieldbus module.

This error is triggered when the communication between the fieldbus module and the master (PLC) is interrupted.



Remedy

- Verify the environment (electromagnetic compatibility).
- Verify the wiring.
- Verify the timeout.
- Replace the option module.
- Contact your local Schneider Electric representative.



Clearing the Error Code

This detected error can be cleared with the **[Auto Fault Reset]** $F E r$ or manually with the **[Fault Reset Assign]** $r S F$ parameter after its cause has been removed.

[CANopen Com Interrupt] $\square \square F$



Probable Cause

Communication interruption on the CANopen® fieldbus.



Remedy

- Verify the communication fieldbus.
- Verify the timeout.
- Refer to the CANopen® manual (EAV64333).



Clearing the Error Code

This detected error can be cleared with the **[Auto Fault Reset]** $F E r$ or manually with the **[Fault Reset Assign]** $r S F$ parameter after its cause has been removed.

[Cooling Pump Error] C_{OPF}



Probable Cause

Cooling pump is not working.



Remedy

Contact your local Schneider Electric representative.



Clearing the Error Code

This detected error can be cleared with the **[Auto Fault Reset]** R_{Lr} or manually with the **[Fault Reset Assign]** r_{5F} parameter after its cause has been removed.

[Precharge Capacitor] C_{rFi}



Probable Cause

- Charging circuit control detected error or charging resistor damaged.
- Supply mains too low.



Remedy

- Turn off the drive and then turn on again.
- Verify the internal connections.
- Verify the voltage and the parameters of **[Undervoltage handling]** u_{5b} .
- Contact your local Schneider Electric representative.



Clearing the Error Code

This detected error can be cleared manually with the **[Extended Fault Reset]** H_{rFL} parameter after the cause has been removed.

[AFE contactor fdbk error] [r F 3]



Probable Cause

This error occurs in different conditions (on start / on stop / during operation).

This error is analysed inside each AFE brick independent from each other. If the AFE mains contactor feedback signal does not match with the internal AFE mains contactor command, the error **[AFE contactor fdbk error] [r F 3]** will be triggered."

On RUN command:

- After the AFE brick internal control has sent the "Main contactor ON-command" it must receive the "Main contactor ON-feedback" within 400ms.

On stop command:

- After the AFE brick internal control has sent the "Main contactor OFF-command" it must receive the "Main contactor OFF-feedback" within 500ms.



Remedy

- Verify the environment (electromagnetic compatibility) related to:
 - Cable routing (control & power not mixed).
 - Ground cabling.
 - Ground Shielding.
- Verify the cables connecting the drive to the motor.
- Verify which AFE brick detected an **[AFE contactor fdbk error] [r F 3]** error, by connecting the Graphic Display Terminal to the AFE brick HMI port and checking the fault history.
- Contact your local Schneider Electric representative.



Clearing the Error Code

This detected error requires a power reset.

[Channel Switch Error] *C S F*



Probable Cause

Switch to an invalid channel.



Remedy

Verify the function parameters.



Clearing the Error Code

This detected error is cleared as soon as its cause has been removed.

[DC Bus Ripple Error] *d C r E*



Probable Cause

Persistent ripple observed on the DC bus or DC bus capacitors damaged.



Remedy

- Turn off the drive and then turn on again.
- Verify correct behavior of the input filter.
- Verify the mains wirings.
- Verify the internal connections.
- Contact your local Schneider Electric representative.



Clearing the Error Code

This detected error requires a power reset.

[Dry Run Error] *d r Y F*



Probable Cause

The dry run monitoring function has detected an error.

NOTE: After the error has been triggered, even if the detected error has been cleared, it is not possible to restart the pump before the end of the **[DryRun Restart Delay]** *d r Y r*.



Remedy

- Verify that the pump is well primed.
- Verify that there is no air leak in the suction line.
- Verify the settings of the monitoring function.



Clearing the Error Code

This detected error can be cleared with the **[Auto Fault Reset]** *A F r* or manually with the **[Fault Reset Assign]** *r S F* parameter after its cause has been removed.

[EEPROM Control] *E E F I*



Probable Cause

An error of the internal memory of the control block has been detected.



Remedy

- Verify the environment (electromagnetic compatibility).
- Switch off the product.
- Return to factory settings.
- Contact your local Schneider Electric representative.



Clearing the Error Code

This detected error requires a power reset.

[EEPROM Power] *E E F 2*



Probable Cause

An error of the internal memory of the power board has been detected.



Remedy

- Verify the environment (electromagnetic compatibility).
- Switch off the product.
- Return to factory settings.
- Contact your local Schneider Electric representative.



Clearing the Error Code

This detected error requires a power reset.

[External Error] *E P F 1*



Probable Cause

- Event triggered by an external device, depending on user.
- An external error has been triggered via Embedded Ethernet.
- The error is caused by an external circuit.
- Ethernet configuration file is corrupted.



Remedy

- Remove the cause of the external error.
- Perform a factory setting of the Ethernet configuration or modify the **IP Mode**.



Clearing the Error Code

This detected error can be cleared with the **[Auto Fault Reset] *R E r*** or manually with the **[Fault Reset Assign] *r 5 F*** parameter after its cause has been removed.

[Fieldbus Error] *E P F 2*



Probable Cause

Event triggered by an external device, depending on user.



Remedy

Remove the cause of the external error.



Clearing the Error Code

This detected error can be cleared with the **[Auto Fault Reset]** *A F R* or manually with the **[Fault Reset Assign]** *r 5 F* parameter after its cause has been removed.

[Embd Eth Com Interrupt] *E E H F*



Probable Cause

Communication interruption on the Ethernet IP ModbusTCP bus.



Remedy

- Verify the communication bus.
- Refer to the Ethernet manual (Embedded(EAV64327); Option(EAV64328)).



Clearing the Error Code

This detected error can be cleared with the **[Auto Fault Reset]** *A F R* or manually with the **[Fault Reset Assign]** *r 5 F* parameter after its cause has been removed.

[Out Contact Closed Error] F C F 1



Probable Cause

The output contactor remains closed although the opening conditions have been met.



Remedy

- Verify the output contactor and its wiring.
- Verify the contactor feedback wiring.



Clearing the Error Code

This detected error requires a power reset.

[Out Contact Opened Error] F C F 2



Probable Cause

The output contactor remains opened although the closing conditions have been met.



Remedy

- Verify the output contactor and its wiring.
- Verify the contactor feedback wiring.



Clearing the Error Code

This detected error can be cleared with the **[Auto Fault Reset] F E r** or manually with the **[Fault Reset Assign] r 5 F** parameter after its cause has been removed.

[FDR 1 Error] *F d r 1*



Probable Cause

- Embedded Ethernet FDR error
- Communication interruption between the drive and the PLC
- Configuration file incompatible, empty or invalid
- Drive rating not consistent with the configuration file



Remedy

- Verify the drive and PLC connection
- Verify the communication workload
- Restart the transfer of configuration file from drive to PLC



Clearing the Error Code

This detected error can be cleared with the **[Auto Fault Reset]** *A F R* or manually with the **[Fault Reset Assign]** *r 5 F* parameter after its cause has been removed.

[FDR 2 Error] *F d r 2*



Probable Cause

- Ethernet fieldbus module FDR error
- Communication interruption between the drive and the PLC
- Configuration file incompatible, empty or corrupted
- Drive rating not consistent with the configuration file



Remedy

- Verify the drive and PLC connection
- Verify the communication workload
- Restart the transfer of configuration file from drive to PLC



Clearing the Error Code

This detected error can be cleared with the **[Auto Fault Reset]** *A F R* or manually with the **[Fault Reset Assign]** *r 5 F* parameter after its cause has been removed.

[Fan Feedback Error] *F F d F*



Probable Cause

Fan speed too low.

[Fan Feedback Warning] *F F d R* warning has been active for a time longer than 10 minutes.



Remedy

Replace the fan.



Clearing the Error Code

This detected error can be cleared with the **[Auto Fault Reset] *R E r*** or manually with the **[Fault Reset Assign] *r S F*** parameter after its cause has been removed.

[Firmware Update Error] *F W E r*



Probable Cause

Firmware update function has detected an error.



Remedy

- Contact your local Schneider Electric representative.



Clearing the Error Code

This detected error is cleared as soon as its cause has been removed.

[Boards Compatibility] H C F



Probable Cause

Hardware configuration error.

The **[Pairing password] P P** , parameter has been enabled and an option module has been changed.



Remedy

- Refit the original option module.
- Confirm the configuration by entering the **[Pairing password] P P** , if the module was changed deliberately.



Clearing the Error Code

This detected error is cleared as soon as its cause has been removed.

[High Flow Error] H F P F



Probable Cause

The high flow monitoring function has detected an error.



Remedy

- Verify that the system works in its flow capabilities.
- Verify that there is no pipe burst at the outlet of the system.
- Verify the settings of the monitoring function.



Clearing the Error Code

This detected error can be cleared with the **[Auto Fault Reset] R L r** or manually with the **[Fault Reset Assign] r 5 F** parameter after its cause has been removed.

[Egy Saving Exit Error] , d L F



Probable Cause

The drive is not turned on even though **[Egy Saving Timeout]** , d L E has elapsed.



Remedy

- Verify the Supply Mains/contactor/drive wiring.
- Verify the timeout.



Clearing the Error Code

This detected error can be cleared with the **[Auto Fault Reset]** R E r or manually with the **[Fault Reset Assign]** r 5 F parameter after its cause has been removed.

[MonitorCircuit A Error] , F R



Probable Cause

The digital input assigned to **[MonitorCircuit A Assign]** , F R R is active for longer than **[MonitorCircuit A Delay]** , F d R.



Remedy

- Verify the connected device and its wiring.
- Verify the **[MonitorCircuit A Assign]** , F R R parameter assignment.



Clearing the Error Code

This detected error can be cleared with the **[Auto Fault Reset]** R E r or manually with the **[Fault Reset Assign]** r 5 F parameter after its cause has been removed.

[MonitorCircuit B Error] , F b



Probable Cause

The digital input assigned to **[MonitorCircuit B Assign]** , F R b is active for longer than **[MonitorCircuit B Delay]** , F d b.



Remedy

- Verify the connected device and its wiring.
- Verify the **[MonitorCircuit B Assign]** , F R b parameter assignment.



Clearing the Error Code

This detected error can be cleared with the **[Auto Fault Reset]** R E r or manually with the **[Fault Reset Assign]** r 5 F parameter after its cause has been removed.

[MonitorCircuit C Error] , F c



Probable Cause

The digital input assigned to **[MonitorCircuit C Assign]** , F R c is active for longer than **[MonitorCircuit C Delay]** , F d c.



Remedy

- Verify the connected device and its wiring.
- Verify the **[MonitorCircuit C Assign]** , F R c parameter assignment.



Clearing the Error Code

This detected error can be cleared with the **[Auto Fault Reset]** R E r or manually with the **[Fault Reset Assign]** r 5 F parameter after its cause has been removed.

[MonitorCircuit D Error] , F d



Probable Cause

The digital input assigned to **[MonitorCircuit D Assign]** , F R d is active for longer than **[MonitorCircuit D Delay]** , F d d.



Remedy

- Verify the connected device and its wiring.
- Verify the **[MonitorCircuit D Assign]** , F R d parameter assignment.



Clearing the Error Code

This detected error can be cleared with the **[Auto Fault Reset]** R E r or manually with the **[Fault Reset Assign]** r S F parameter after its cause has been removed.

[Input Overheating] , H F



Probable Cause

The AFE brick temperature is too high.



Remedy

Verify the drive ventilation and the ambient temperature. Wait for the drive to cool down before restarting.



Clearing the Error Code

This detected error can be cleared with the **[Auto Fault Reset]** R E r or manually with the **[Fault Reset Assign]** r S F parameter after its cause has been removed.

[Internal Link Error] *ILF*



Probable Cause

Communication interruption between option module and the drive.



Remedy

- Verify the environment (electromagnetic compatibility).
- Verify the connections.
- Replace the option module.
- Contact your local Schneider Electric representative.



Clearing the Error Code

This detected error requires a power reset.

[Internal Error 0] *INF0*



Probable Cause

- Communication interruption between microprocessors of the control board.
- The power board rating is not valid.



Remedy

Contact your local Schneider Electric representative.



Clearing the Error Code

This detected error requires a power reset.

[Internal Error 1] *INF 1*



Probable Cause

The power board rating is not valid.



Remedy

Contact your local Schneider Electric representative.



Clearing the Error Code

This detected error requires a power reset.

[Internal Error 2] *INF 2*



Probable Cause

The power board is incompatible with the control block software.



Remedy

Contact your local Schneider Electric representative.



Clearing the Error Code

This detected error requires a power reset.

[Internal Error 3] *INF3*



Probable Cause

Internal communication detected error.



Remedy

- Verify the wiring on drive control terminals (internal 10V supply for analog inputs overloaded).
- Contact your local Schneider Electric representative.



Clearing the Error Code

This detected error requires a power reset.

[Internal Error 4] *INF4*



Probable Cause

Internal data inconsistent.



Remedy

Contact your local Schneider Electric representative.



Clearing the Error Code

This detected error requires a power reset.

[Internal Error 6] *INF 6*



Probable Cause

- The option module installed in the drive is not recognized.
- The removable control terminal modules (if existing) are not present or not recognized.
- The embedded Ethernet adapter is not recognized.



Remedy

- Verify the catalog number and compatibility of the option module.
- Plug the removable control terminal modules after the drive has been switched off.
- Contact your local Schneider Electric representative.



Clearing the Error Code

This detected error requires a power reset.

[Internal Error 7] *INF 7*



Probable Cause

Communication interruption with CPLD component of Control board.



Remedy

Contact your local Schneider Electric representative.



Clearing the Error Code

This detected error requires a power reset.

[Internal Error 8] *INFB*



Probable Cause

The internal power switching supply is not correct.



Remedy

Contact your local Schneider Electric representative.



Clearing the Error Code

This detected error requires a power reset.

[Internal Error 9] *INF9*



Probable Cause

An error on the current circuit measurement has been detected.



Remedy

Contact your local Schneider Electric representative.



Clearing the Error Code

This detected error can be cleared with the **[Auto Fault Reset]** *FLR* or manually with the **[Fault Reset Assign]** *r5F* parameter after its cause has been removed.

[Internal Error 10] *i n F R*



Probable Cause

The input stage is not operating correctly.



Remedy

Contact your local Schneider Electric representative.



Clearing the Error Code

This detected error requires a power reset.

[Internal Error 11] *i n F b*



Probable Cause

The internal drive thermal sensor is not operating correctly.



Remedy

Contact your local Schneider Electric representative.



Clearing the Error Code

This detected error can be cleared with the **[Auto Fault Reset]** *R E r* or manually with the **[Fault Reset Assign]** *r 5 F* parameter after its cause has been removed.

[Internal Error 12] *INFL*



Probable Cause

Internal current supply error.



Remedy

Contact your local Schneider Electric representative.



Clearing the Error Code

This detected error requires a power reset.

[Internal Error 13] *INFD*



Probable Cause

Differential current deviation.



Remedy

Verify connection of DigiLink cable (GG45).

Contact your local Schneider Electric representative.



Clearing the Error Code

This detected error can be cleared manually with the **[Extended Fault Reset]** *HRFL* parameter after the cause has been removed.

[Internal Error 14] *INFE*



Probable Cause

Internal microprocessor detected error.



Remedy

- Verify that the error code can be cleared.
- Contact your local Schneider Electric representative.



Clearing the Error Code

This detected error requires a power reset.

[Internal Error 15] *INFF*



Probable Cause

Serial memory flash format error.



Remedy

Contact your local Schneider Electric representative.



Clearing the Error Code

This detected error requires a power reset.

[Internal Error 16] *INF G*



Probable Cause

Communication interruption or internal error of output relays option module



Remedy

- Verify that the option module is correctly connected to the slot
- Replace the option module.
- Contact your local Schneider Electric representative.



Clearing the Error Code

This detected error requires a power reset.

[Internal Error 17] *INF H*



Probable Cause

Communication interruption with the Extension module of digital & analog I/O or internal error of the Extension module of digital & analog I/O.



Remedy

- Verify that the option module is correctly connected to the slot
- Replace the option module.
- Contact your local Schneider Electric representative.



Clearing the Error Code

This detected error requires a power reset.

[Internal Error 20] *INFK*



Probable Cause

Option module interface board error.



Remedy

Contact your local Schneider Electric representative.



Clearing the Error Code

This detected error requires a power reset.

[Internal Error 21] *INFL*



Probable Cause

Internal Real Time Clock error. It could be a communication error between the keypad and the drive or a clock oscillator start error.



Remedy

Contact your local Schneider Electric representative.



Clearing the Error Code

This detected error requires a power reset.

[Internal Error 22] *inFn*



Probable Cause

An error on the embedded Ethernet adapter has been detected.



Remedy

Verify the connection to the Ethernet port.

Contact your local Schneider Electric representative.



Clearing the Error Code

This detected error requires a power reset.

[Internal Error 23] *inFn*



Probable Cause

A communication interruption between the control block and AFE or BU bricks has been detected.



Remedy

Contact your local Schneider Electric representative.



Clearing the Error Code

This detected error requires a power reset.

[Internal Error 25] *INFP*



Probable Cause

Incompatibility between Control Board hardware version and firmware version.



Remedy

- Update the firmware package.
- Contact your local Schneider Electric representative.



Clearing the Error Code

This detected error requires a power reset.

[Internal Error 27] *INFR*



Probable Cause

Diagnostics in CPLD have detected an error.



Remedy

Contact your local Schneider Electric representative.



Clearing the Error Code

This detected error requires a power reset.

[Internal Error 28] *INF5*



Probable Cause

An error on the AFE brick has been detected.



Remedy

Contact your local Schneider Electric representative.



Clearing the Error Code

This detected error requires a power reset.

[Internal Error 29] *INF6*



Probable Cause

An error on the power unit / inverter brick has been detected.



Remedy

Contact your local Schneider Electric representative.



Clearing the Error Code

This detected error requires a power reset.

[Internal Error 30] *i n F u*



Probable Cause

An error on the rectifier brick has been detected or an **[Input phase loss] P H F** error has been triggered when the DC bus is charged.



Remedy

Turn off the drive and then turn on again.

If **[Input phase loss] P H F** error code replaces **[Internal Error 30] *i n F u***, refer to the instructions of **[Input phase loss] P H F** error otherwise contact your local Schneider Electric representative.



Clearing the Error Code

This detected error requires a power reset.

[Internal Error 31] *i n F V*



Probable Cause

An error on the brick architecture has been detected (brick unavailable).



Remedy

Contact your local Schneider Electric representative.



Clearing the Error Code

This detected error can be cleared with the **[Auto Fault Reset] R E r** or manually with the **[Fault Reset Assign] r 5 F** parameter after its cause has been removed.

[Inlet Pressure Error] *IPPF*



Probable Cause

The inlet pressure monitoring function has detected an error.



Remedy

- Search for a possible cause of low pressure at the inlet of system.
- Verify the settings of the monitoring function.



Clearing the Error Code

This detected error can be cleared with the **[Auto Fault Reset]** *AR* or manually with the **[Fault Reset Assign]** *r5F* parameter after its cause has been removed.

[Anti Jam Error] *JANF*



Probable Cause

The Anti-Jam monitoring function has exceeded the maximum number of sequences allowed in the time window.



Remedy

- Search for a clogging substance in the impeller.
- Verify the settings of the monitoring function.



Clearing the Error Code

This detected error can be cleared with the **[Auto Fault Reset]** *AR* or manually with the **[Fault Reset Assign]** *r5F* parameter after its cause has been removed.

[Input Contactor] L C F



Probable Cause

The drive is not switched on even though **[Mains V. time out] L C E** timeout has elapsed.



Remedy

- Verify the input contactor and its wiring.
- Verify the **[Mains V. time out] L C E** timeout.
- Verify the supply mains/contactor/drive wiring.



Clearing the Error Code

This detected error can be cleared with the **[Auto Fault Reset] H E r** or manually with the **[Fault Reset Assign] r 5 F** parameter after its cause has been removed.

[High Level Error] L C H F



Probable Cause

The maximum level switch is active during filling process.



Remedy

- Verify the parameter **[Max Level Switch Assign] L C W H**.
- Verify the state of the corresponding drive digital input and its wiring.



Clearing the Error Code

This detected error can be cleared with the **[Auto Fault Reset] H E r** or manually with the **[Fault Reset Assign] r 5 F** parameter after its cause has been removed.

[Low Level Error] L L L F



Probable Cause

The minimum level switch is active during emptying process.



Remedy

- Verify the parameter **[Min Level Switch Assign] L L W L**.
- Verify the state of the corresponding drive digital input and its wiring.



Clearing the Error Code

This detected error can be cleared with the **[Auto Fault Reset] R L r** or manually with the **[Fault Reset Assign] r 5 F** parameter after its cause has been removed.

[AI1 4-20mA loss] L F F I



Probable Cause

Loss of the 4-20 mA on analog input AI1.

This error is triggered when the measured current is below 2 mA.



Remedy

- Verify the connection on the analog inputs.
- Verify the setting of **[AI1 4-20mA loss] L F L I** parameter.



Clearing the Error Code

This detected error can be cleared with the **[Auto Fault Reset] R L r** or manually with the **[Fault Reset Assign] r 5 F** parameter after its cause has been removed.

[AI2 4-20mA loss] L F F 2



Probable Cause

Loss of the 4-20 mA on analog input AI2.

This error is triggered when the measured current is below 2 mA.



Remedy

- Verify the connection on the analog inputs.
- Verify the setting of **[AI2 4-20mA loss] L F L 2** parameter.



Clearing the Error Code

This detected error can be cleared with the **[Auto Fault Reset] F L r** or manually with the **[Fault Reset Assign] r 5 F** parameter after its cause has been removed.

[AI3 4-20mA loss] L F F 3



Probable Cause

Loss of the 4-20 mA on analog input AI3.

This error is triggered when the measured current is below 2 mA.



Remedy

- Verify the connection on the analog inputs.
- Verify the setting of **[AI3 4-20mA loss] L F L 3** parameter.



Clearing the Error Code

This detected error can be cleared with the **[Auto Fault Reset] F L r** or manually with the **[Fault Reset Assign] r 5 F** parameter after its cause has been removed.

[AI4 4-20mA loss] L F F 4



Probable Cause

Loss of the 4-20 mA on analog input AI4.

This error is triggered when the measured current is below 2mA.



Remedy

- Verify the connection on the analog inputs.
- Verify the setting of **[AI4 4-20mA loss] L F L 4** parameter.



Clearing the Error Code

This detected error can be cleared with the **[Auto Fault Reset] R L r** or manually with the **[Fault Reset Assign] r 5 F** parameter after its cause has been removed.

[AI5 4-20mA loss] L F F 5



Probable Cause

Loss of the 4-20 mA on analog input AI5.

This error is triggered when the measured current is below 2 mA.



Remedy

- Verify the connection on the analog inputs.
- Verify the setting of **[AI5 4-20mA loss] L F L 5** parameter.



Clearing the Error Code

This detected error can be cleared with the **[Auto Fault Reset] R L r** or manually with the **[Fault Reset Assign] r 5 F** parameter after its cause has been removed.

[ON Lock Error] *L K 0 n*



Probable Cause

External device not ready.



Remedy

Verify external device assigned to ON lock input.



Clearing the Error Code

This detected error can be cleared with the **[Auto Fault Reset]** *A E r* or manually with the **[Fault Reset Assign]** *r 5 F* parameter after its cause has been removed.

[MultiDrive Link Error] *n d L F*



Probable Cause

- The communication has been interrupted while running.
- The function has detected an inconsistency in the system configuration.



Remedy

- Check the communication network.
- Check the configuration of the multi-drive link function.



Clearing the Error Code

This detected error can be cleared with the **[Auto Fault Reset]** *A E r* or manually with the **[Fault Reset Assign]** *r 5 F* parameter after its cause has been removed.

[Mains Freq Out Of Range] $\Pi F F$



Probable Cause

[Mains Frequency] $F R L$ on the AFE brick is out of range.



Remedy

Verify the mains frequency.



Clearing the Error Code

This detected error can be cleared manually with the [Fault Reset Assign] $r 5 F$ parameter after its cause has been removed.

[Module Overheat] $\Pi O F$



Probable Cause

Cabinet temperature too high.

[Module Overheat] $\Pi O R$ warning has been active for a time longer than 10 minutes.



Remedy

Verify the cooling of the cabinet.



Clearing the Error Code

This detected error can be cleared with the [Auto Fault Reset] $R L r$ or manually with the [Fault Reset Assign] $r 5 F$ parameter after its cause has been removed.

[M/P Device Error] $\Pi P d F$



Probable Cause

A device on the MultiDrive Link architecture is missing.



Remedy

Check the communication network.



Clearing the Error Code

This detected error can be cleared with the **[Auto Fault Reset]** $r E r$ or manually with the **[Fault Reset Assign]** $r 5 F$ parameter after its cause has been removed.

[Lead Pump Error] $\Pi P L F$



Probable Cause

The selected lead pump is not available while in run.



Remedy

Verify the state of the corresponding drive digital input for the pump availability information (for example **[Pump 1 Ready Assign]** $\Pi P \cdot I$ for the pump 1).



Clearing the Error Code

This detected error can be cleared with the **[Auto Fault Reset]** $R E r$ or manually with the **[Fault Reset Assign]** $r 5 F$ parameter after its cause has been removed.

[DC Bus Overvoltage] $\square b F$



Probable Cause

- Deceleration time too short or driving load too high.
- Supply mains voltage too high.



Remedy

- Increase the deceleration time.
- Configure the **[Dec ramp adapt.]** $b r R$ function if it is compatible with the application.
- Verify the supply mains voltage.



Clearing the Error Code

This detected error can be cleared with the **[Auto Fault Reset]** $R E r$ or manually with the **[Fault Reset Assign]** $r 5 F$ parameter after its cause has been removed.

[AFE Bus unbalancing] $\alpha b F 2$



Probable Cause

- AFE DC bus unbalancing.
- Supply mains voltage too high.
- Total generative power too high



Remedy

- Verify the supply mains voltage.
- Contact your local Schneider Electric representative



Clearing the Error Code

This detected error can be cleared with the **[Auto Fault Reset]** $F E r$ or manually with the **[Fault Reset Assign]** $r 5 F$ parameter after its cause has been removed.

[Overcurrent] $\alpha C F$



Probable Cause

- Parameters in the **[Motor data]** $\Pi \alpha R$ - menu are not correct.
- Inertia or load too high.
- Mechanical locking.



Remedy

- Verify the motor parameters.
- Verify the size of the motor/drive/load.
- Verify the state of the mechanism.
- Decrease **[Current limitation]** $C L r$.
- Increase the switching frequency.



Clearing the Error Code

This detected error requires a power reset.

[Drive Overheating] □ H F



Probable Cause

Drive temperature too high.



Remedy

Verify the motor load, the drive ventilation, and the ambient temperature. Wait for the drive to cool down before restarting.



Clearing the Error Code

This detected error can be cleared with the **[Auto Fault Reset]** *R L r* or manually with the **[Fault Reset Assign]** *r 5 F* parameter after its cause has been removed.

[Process Overload] □ L C



Probable Cause

Process overload.



Remedy

- Verify and remove the cause of the overload.
- Verify the parameters of the **[Process overload]** □ L d - function.



Clearing the Error Code

This detected error can be cleared with the **[Auto Fault Reset]** *R L r* or manually with the **[Fault Reset Assign]** *r 5 F* parameter after its cause has been removed.

[Motor Overload] \square L F



Probable Cause

Triggered by excessive motor current.



Remedy

- Verify the setting of the motor thermal monitoring
- Verify the motor load. Wait for the motor to cool down before restarting
- Verify the setting of the following parameters:
 - **[Motor Th Current]** r L H
 - **[Motor Thermal Mode]** r H L
 - **[Motor Therm Thd]** r L d
 - **[MotorTemp ErrorResp]** \square L L



Clearing the Error Code

This detected error can be cleared with the **[Auto Fault Reset]** r L r or manually with the **[Fault Reset Assign]** r 5 F parameter after its cause has been removed.

[Single Output Phase Loss] \square P F I



Probable Cause

Loss of one phase at drive output.



Remedy

Verify the wiring from the drive to the motor.



Clearing the Error Code

This detected error can be cleared with the **[Auto Fault Reset]** r L r or manually with the **[Fault Reset Assign]** r 5 F parameter after its cause has been removed.

[Output Phase Loss] $\square P F \varrho$



Probable Cause

- Motor not connected or motor power too low.
- Output contactor opened.
- Instantaneous instability in the motor current.



Remedy

- Verify the wiring from the drive to the motor.
- If an output contactor is being used, set **[OutPhaseLoss Assign]** OPL to **[No Error Triggered]** OAC.
- If the drive is connected to a low-power motor or not connected to a motor: In factory settings mode, motor phase loss detection is active **[Output Phase Loss] $\square P L =$ [OPF Error Triggered] $\varphi E 5$** . Deactivate motor phase loss detection **[Output Phase Loss] $\square P L =$ [Function Inactive] $\square \square$** .
- Verify and optimize the following parameters: **[IR compensation] $\mu F r$** , **[Nom Motor Voltage] $\mu n 5$** and **[Rated mot. current] $n C r$** and perform **[Autotuning] $t \mu n$** .



Clearing the Error Code

This detected error can be cleared with the **[Auto Fault Reset] $R E r$** or manually with the **[Fault Reset Assign] $r 5 F$** parameter after its cause has been removed.

[Out Pressure High] \square P H F



Probable Cause

The outlet pressure monitoring function has detected a high-pressure error.



Remedy

- Search for a possible cause of high pressure at the outlet of system.
- Verify the settings of the monitoring function.



Clearing the Error Code

This detected error can be cleared with the **[Auto Fault Reset]** $P L r$ or manually with the **[Fault Reset Assign]** $r 5 F$ parameter after its cause has been removed.

[Out Pressure Low] □ P L F



Probable Cause

The outlet pressure monitoring function has detected a low-pressure error.



Remedy

- Verify that there is no pipe broken at the outlet of the system.
- Search for a possible cause of low pressure at the outlet of system.
- Verify the settings of the monitoring function.



Clearing the Error Code

This detected error can be cleared with the **[Auto Fault Reset]** *A L r* or manually with the **[Fault Reset Assign]** *r 5 F* parameter after its cause has been removed.

[Supply Mains Overvoltage] □ 5 F



Probable Cause

- Supply mains voltage too high.
- Disturbed supply mains.



Remedy

Verify the supply mains voltage.



Clearing the Error Code

This detected error can be cleared with the **[Auto Fault Reset]** *A L r* or manually with the **[Fault Reset Assign]** *r 5 F* parameter after its cause has been removed.

[Cab I/O 24V Error] P 2 4 C



Probable Cause

The input DI58 is used to monitor the 24V on input terminal. If it breaks down, all inputs are suppressed to avoid unintended error messages (from software version V1.6V1.3).

- DI58 cabinet I/O input is not wired to the internal terminal X231.
- DI58 is used by another cabinet I/O function.



Remedy

- Verify if the terminal X231 is wired to the cabinet I/O input DI58.
- If the DI58 is used by another cabinet function, it is needed to change the function to another free cabinet I/O input on the X220 terminals. Additionally, it is needed to adapt the parameter setting of the new selected input.



Clearing the Error Code

This detected error can be cleared with the **[Auto Fault Reset]** *r E r* or manually with the **[Fault Reset Assign]** *r 5 F* parameter after its cause has been removed.

[PumpCycle Start Error] P C P F



Probable Cause

The Pumpcycle monitoring function has exceeded the maximum number of start sequences allowed in the time window.



Remedy

- Search for a possible cause of repetitive start of system.
- Verify the settings of the monitoring function.



Clearing the Error Code

This detected error can be cleared with the **[Auto Fault Reset]** *r E r* or manually with the **[Fault Reset Assign]** *r 5 F* parameter after its cause has been removed.

[PID Feedback Error] P F Π F



Probable Cause

The PID feedback error was out of the allowed range around the set point during the time window.



Remedy

- Check for mechanical breakdown of pipes.
- Check for water leakage.
- Check for open discharge valve.
- Check for fire hydrant opened.
- Verify the settings of the monitoring function.



Clearing the Error Code

This detected error can be cleared with the **[Auto Fault Reset]** *R L r* or manually with the **[Fault Reset Assign]** *r 5 F* parameter after its cause has been removed.

[Program Loading Error] P G L F



Probable Cause

Verify that the error code can be cleared.



Remedy

Contact your local Schneider Electric representative.



Clearing the Error Code

This detected error is cleared as soon as its cause has been removed.

[Program Running Error] *P G r F*



Probable Cause

Verify that the error code can be cleared.



Remedy

Contact your local Schneider Electric representative.



Clearing the Error Code

This detected error requires a power reset.

[Input phase loss] *P H F*



Probable Cause

- Drive incorrectly supplied or a tripped fused.
- One phase is unavailable.
- 3-phase Drive used on a single-phase supply mains.
- Unbalanced load.



Remedy

- Verify the power connection and the fuses.
- Use a 3-phase supply mains.
- Disable the detected error by **[Input phase loss]** *i P L = [No]* *n o* if single phase supply mains or DC bus supply is used.



Clearing the Error Code

This detected error is cleared as soon as its cause has been removed.

[Pump Low Flow Error] *PLFF*



Probable Cause

The pump low flow monitoring function has detected an error.



Remedy

- Verify valve is closed on discharge.
- Pipes are damaged on the discharge.
- Search for a possible cause of low flow at the outlet of system.
- Verify the settings of the monitoring function.



Clearing the Error Code

This detected error can be cleared with the **[Auto Fault Reset]** *RLr* or manually with the **[Fault Reset Assign]** *r5F* parameter after its cause has been removed.

[Safety Function Error] *SFFF*



Probable Cause

- Debounce time exceeded.
- Internal hardware error.
- STOA and STOB have a different status (high/low) for more than 1 second.



Remedy

- Verify the wiring of the digital inputs STOA and STOB.
- Contact your local Schneider Electric representative.



Clearing the Error Code

This detected error requires a power reset.

[Motor short circuit] 5 C F 1



Probable Cause

Short-circuit or grounding at the drive output.



Remedy

- Verify the cables connecting the drive to the motor, and the motor insulation.
- Adjust the switching frequency.
- Connect chokes in series with the motor.



Clearing the Error Code

This detected error can be cleared manually with the **[Extended Fault Reset]** $H r F C$ parameter after the cause has been removed.

[Ground Short Circuit] 5 C F 3



Probable Cause

Significant ground leakage current at the drive output if several motors are connected in parallel.



Remedy

- Verify the cables connecting the drive to the motor, and the motor insulation.
- Adjust the switching frequency.
- Connect chokes in series with the motor.
- If you have long cables, verify the setting of **[Ground Fault Activation]** $G r F L$.



Clearing the Error Code

This detected error requires a power reset.

[IGBT Short Circuit] 5 C F 4



Probable Cause

Power component detected error.

At product power-on, the IGBTs are tested for short circuit. Thereby an error (short circuit or interruption) has been detected on at least one IGBT. The time to check each transistor is between 1 and 10 μ s.



Remedy

Verify the setting of **[Output Short Circuit Test] 5 E r E** parameter.

Contact your local Schneider Electric representative.



Clearing the Error Code

This detected error can be cleared with the **[Auto Fault Reset] R E r** or manually with the **[Fault Reset Assign] r 5 F** parameter after its cause has been removed.

[Motor Short Circuit] 5 C F 5



Probable Cause

Short-circuit at drive output.



Remedy

- Verify the cables connecting the drive to the motor, and the motor's insulation.
- Contact your local Schneider Electric representative.



Clearing the Error Code

This detected error can be cleared with the **[Auto Fault Reset] R E r** or manually with the **[Fault Reset Assign] r 5 F** parameter after its cause has been removed.

[AFE ShortCircuit error] 5 C F 6



Probable Cause

AFE rectifier IGBT short-circuit.

AFE over current due to power factor correction systems in the grid. Each switch of the capacitor produces over voltage in the mains which can lead an over current in the AFE.



Remedy

- Verify the mains voltage when the power factor correction system is changing the capacitive load. Install only power factor correction systems with integrated reactors
- Verify the cables connecting the AFE brick to the mains.
- Contact your local Schneider Electric representative.



Clearing the Error Code

This detected error requires a power reset.

[Modbus Com Interruption] 5 L F 1



Probable Cause

Communication interruption on the Modbus port.



Remedy

- Verify the communication bus.
- Verify the timeout.
- Refer to the Modbus user manual.



Clearing the Error Code

This detected error can be cleared with the **[Auto Fault Reset]** *FEr* or manually with the **[Fault Reset Assign]** *r5F* parameter after its cause has been removed.

[PC Com Interruption] 5 L F 2



Probable Cause

Communication interruption with the commissioning software.



Remedy

- Verify the commissioning software connecting cable.
- Verify the timeout.



Clearing the Error Code

This detected error can be cleared with the **[Auto Fault Reset] R L r** or manually with the **[Fault Reset Assign] r 5 F** parameter after its cause has been removed.

[HMI Com Interruption] 5 L F 3



Probable Cause

Communication interruption with the Graphic display terminal.

This error is triggered when the command or reference value are given using the Graphic Display Terminal and if the communication is interrupted during more than 2 seconds.



Remedy

- Verify the Graphic display terminal connection.
- Verify the timeout.



Clearing the Error Code

This detected error can be cleared with the **[Auto Fault Reset] R L r** or manually with the **[Fault Reset Assign] r 5 F** parameter after its cause has been removed.

[Motor Overspeed] 5 0 F



Probable Cause

- Instability or driving load too high.
- If a downstream contactor is used, the contacts between the motor and the drive have not been closed before applying a Run command.
- The overspeed threshold (corresponding to 110 % of **[Max frequency]** f_r) has been reached.



Remedy

- Verify the motor parameter settings.
- Verify the size of the motor/drive/load.
- Verify and close the contacts between the motor and the drive before applying a Run command.
- Verify the consistency between **[Max frequency]** f_r and **[High Speed]** HSP . It is recommended to have at least **[Max frequency]** $f_r \geq 110\% * \text{[High Speed]} HSP$.



Clearing the Error Code

This detected error can be cleared manually with the **[Fault Reset Assign]** r_{5F} parameter after its cause has been removed.

[Security Files Corrupt] 5 P F C



Probable Cause

Security files corrupted or missing.



Remedy

Switch off the product. At next switch-on, the security file will be created again, and the information related to cybersecurity (such as channel policy and password) are set back to the default value.



Clearing the Error Code

This detected error requires a power reset.

[Motor Stall Error] 5 L F



Probable Cause

The stall monitoring function has detected an error.

The **[Motor Stall Error] 5 L F** is triggered on the following conditions:

- The output frequency is smaller than the stalling frequency **[Stall Frequency] 5 L P 3**
- The output current is higher than the stalling current **[Stall Current] 5 L P 2**
- For a duration longer than the stalling time **S[Stall Max Time] 5 L P 1**.



Remedy

- Search for a mechanical blocking of the motor.
- Search for a possible cause of motor overload.
- Verify the settings of the monitoring function.



Clearing the Error Code

This detected error can be cleared with the **[Auto Fault Reset] R L r** or manually with the **[Fault Reset Assign] r 5 F** parameter after its cause has been removed.

[AI2 Thermal Sensor Error] $\text{E } 2 \text{ C } F$



Probable Cause

The thermal sensor monitoring function has detected a thermal sensor error on analog input AI2:

- Open circuit, or
- Short circuit.



Remedy

- Verify the sensor and its wiring.
- Replace the sensor.
- Verify the setting of **[AI2 Type]** $H \text{ } 1 \text{ } 2 \text{ E}$ parameter.



Clearing the Error Code

This detected error can be cleared with the **[Auto Fault Reset]** $H \text{ E } r$ or manually with the **[Fault Reset Assign]** $r \text{ } 5 \text{ F}$ parameter after its cause has been removed.

[AI3 Thermal Sensor Error] $\text{E} \exists \text{L} \text{F}$



Probable Cause

The thermal monitoring function has detected an error of the thermal sensor connected to the analog input AI3:

- Open circuit, or
- Short circuit



Remedy

- Verify the sensor and its wiring.
- Replace the sensor.
- Verify the setting of **[AI3 Type]** $\text{P} \text{ } \text{ } \text{L}$ parameter.



Clearing the Error Code

This detected error can be cleared with the **[Auto Fault Reset]** $\text{P} \text{L} \text{r}$ or manually with the **[Fault Reset Assign]** $\text{r} \text{ } \text{5} \text{F}$ parameter after its cause has been removed.

[AI4 Thermal Sensor Error] E 4 C F



Probable Cause

The thermal monitoring function has detected an error of the thermal sensor connected to the analog input AI4:

- Open circuit, or
- Short circuit



Remedy

- Verify the sensor and its wiring.
- Replace the sensor.
- Verify the setting of **[AI4 Type] P 1 4 E** parameter



Clearing the Error Code

This detected error can be cleared with the **[Auto Fault Reset] P E r** or manually with the **[Fault Reset Assign] r 5 F** parameter after its cause has been removed.

[AI5 Thermal Sensor Error] E 5 CF



Probable Cause

The thermal monitoring function has detected an error of the thermal sensor connected to the analog input AI5:

- Open circuit, or
- Short circuit



Remedy

- Verify the sensor and its wiring.
- Replace the sensor.
- Verify the setting of **[AI5 Type]** $R 15 E$ parameter.



Clearing the Error Code

This detected error can be cleared with the **[Auto Fault Reset]** $R E r$ or manually with the **[Fault Reset Assign]** $r 5 F$ parameter after its cause has been removed.

[MotorWinding A Error] E F R



Probable Cause

The digital input assigned to **[MotorWinding A Assign]** $E F R R$ is active for longer than **[MotorWinding A Delay]** $E F d R$.



Remedy

- Verify the connected device (motor winding thermal switch) and its wiring.
- Verify the motor load and the ambient temperature. Wait for the motor to cool down before restarting.



Clearing the Error Code

This detected error can be cleared with the **[Auto Fault Reset]** $R E r$ or manually with the **[Fault Reset Assign]** $r 5 F$ parameter after its cause has been removed.

[MotorWinding B Error] $\epsilon F b$



Probable Cause

The digital input assigned to **[MotorWinding B Assign]** $\epsilon F B b$ is active for longer than **[MotorWinding B Delay]** $\epsilon F d b$.



Remedy

- Verify the connected device (motor winding thermal switch) and its wiring.
- Verify the motor load and the ambient temperature. Wait for the motor to cool down before restarting.



Clearing the Error Code

This detected error can be cleared with the **[Auto Fault Reset]** $R \epsilon r$ or manually with the **[Fault Reset Assign]** $r 5 F$ parameter after its cause has been removed.

[MotorBearing A Error] $\epsilon F C$



Probable Cause

The digital input assigned to **[MotorBearing A Assign]** $\epsilon F A C$ is active for longer than **[MotorBearing A Delay]** $\epsilon F d C$.



Remedy

- Verify the connected device (motor winding thermal switch) and its wiring.
- Verify the motor load and the ambient temperature. Wait for the motor to cool down before restarting.



Clearing the Error Code

This detected error can be cleared with the **[Auto Fault Reset]** $R \epsilon r$ or manually with the **[Fault Reset Assign]** $r 5 F$ parameter after its cause has been removed.

[MotorBearing B Error] E F d



Probable Cause

The digital input assigned to **[MotorBearing B Assign]** E F A d is active for longer than **[MotorBearing B Delay]** E F d d .



Remedy

- Verify the connected device (motor winding thermal switch) and its wiring.
- Verify the motor load and the ambient temperature. Wait for the motor to cool down before restarting.



Clearing the Error Code

This detected error can be cleared with the **[Auto Fault Reset]** A E r or manually with the **[Fault Reset Assign]** r 5 F parameter after its cause has been removed.

[AI2 Th Level Error] E H 2 F



Probable Cause

The thermal sensor monitoring function has detected a high temperature error on analog input AI2.



Remedy

- Search for a possible cause of overheating.
- Verify the settings of the monitoring function.



Clearing the Error Code

This detected error can be cleared with the **[Auto Fault Reset]** A E r or manually with the **[Fault Reset Assign]** r 5 F parameter after its cause has been removed.

[AI3 Th Level Error] *EH3F*



Probable Cause

The thermal sensor monitoring function has detected a high temperature on analog input AI3.



Remedy

- Search for a possible cause of overheating.
- Verify the settings of the monitoring function.



Clearing the Error Code

This detected error can be cleared with the **[Auto Fault Reset]** *AEr* or manually with the **[Fault Reset Assign]** *r5F* parameter after its cause has been removed.

[AI4 Th Level Error] *EH4F*



Probable Cause

The thermal sensor monitoring function has detected a high temperature on analog input AI4.



Remedy

- Search for a possible cause of overheating.
- Verify the settings of the monitoring function.



Clearing the Error Code

This detected error can be cleared with the **[Auto Fault Reset]** *AEr* or manually with the **[Fault Reset Assign]** *r5F* parameter after its cause has been removed.

[AI5 Th Level Error] *LEHF*



Probable Cause

The thermal sensor monitoring function has detected a high temperature on analog input AI5.



Remedy

- Search for a possible cause of overheating.
- Verify the settings of the monitoring function.



Clearing the Error Code

This detected error can be cleared with the **[Auto Fault Reset]** *ALr* or manually with the **[Fault Reset Assign]** *r5F* parameter after its cause has been removed.

[IGBT Overheating] *LEJF*



Probable Cause

Drive power stage overheating.



Remedy

- Verify the size of the load/motor/drive according to environment conditions.
- Reduce the switching frequency.
- Increase the ramp time.
- Decrease the current limitation.



Clearing the Error Code

This detected error can be cleared with the **[Auto Fault Reset]** *ALr* or manually with the **[Fault Reset Assign]** *r5F* parameter after its cause has been removed.

[AFE IGBT over-heat error] $E J F 2$



Probable Cause

Rectifier IGBT power stage overheating.



Remedy

- Verify the size of the load/motor/drive according to environment conditions.
- Verify and clean, if necessary, the cooling channel.
- Clean or replace the filter mats on IP54 products.



Clearing the Error Code

This detected error can be cleared with the **[Auto Fault Reset]** $H E r$ or manually with the **[Fault Reset Assign]** $r 5 F$ parameter after its cause has been removed.

[Autotuning Error] $E n F$



Probable Cause

- Special motor or motor whose power is not suitable for the drive.
- Motor not connected to the drive.
- Motor not stopped.



Remedy

- Verify that the motor/drive are compatible.
- Verify that the motor is connected to the drive during autotuning.
- If an output contactor is being used, verify that it is closed during autotuning.
- Verify that the motor is present and stopped during autotuning.
- In case of reluctance motor, reduce **[PSI Align Curr Max]** MCr.



Clearing the Error Code

This detected error can be cleared manually with the **[Fault Reset Assign]** $r 5 F$ parameter after its cause has been removed.

[Process Underload] $\cup L F$



Probable Cause

Process underload.



Remedy

- Verify and remove the cause of the underload.
- Verify the parameters of the **[Process underload]** $\cup L d$ - function



Clearing the Error Code

This detected error can be cleared with the **[Auto Fault Reset]** $R E r$ or manually with the **[Fault Reset Assign]** $r 5 F$ parameter after its cause has been removed.

[AFE Mains Undervoltage] $\cup r F$



Probable Cause

- Too low DC-Bus voltage due to mains undervoltage.
- AFE overload.



Remedy

- Verify mains voltage.
- Verify the size of the load/motor/drive according to environment conditions.



Clearing the Error Code

This detected error is cleared as soon as its cause has been removed.

[Supply Mains UnderV] \cup 5 F



Probable Cause

- Supply mains too low.
- Transient voltage dips.



Remedy

Verify the voltage and the parameters of **[Undervoltage handling]** \cup 5 b.



Clearing the Error Code

This detected error is cleared as soon as its cause has been removed.

[VxCtrl Error] V \subset F



Probable Cause

Invalid power reference curve or warning still present after the error delay **[Error Delay]** V \subset F d.



Remedy

- Verify that the parameters of the Power vs Speed reference curve set in the preset mode **[Preset Curve Mode]** P 5 E are valid.
- Verify the setting of the **[Low Learning speed]** V \subset 5 J and **[High Learning speed]** V \subset 5 K.



Clearing the Error Code

This detected error can be cleared with the **[Auto Fault Reset]** H E r or manually with the **[Fault Reset Assign]** r 5 F parameter after its cause has been removed.

FAQ

Introduction

If the display does not light up, verify the supply mains to the drive.

The assignment of the fast stop or freewheel functions help to prevent the drive starting if the corresponding digital inputs are not switched on. The drive then displays **[Freewheel]** $n\ 5\ E$ in freewheel stop and **[Fast stop]** $F\ 5\ E$ in fast stop. This is a normal behavior since these functions are active at zero so that the drive is stopped if there is a wire break.

Verify that the run command input is activated in accordance with the selected control mode (**[2/3-wire control]** $E\ C\ C$ and **[2-wire type]** $E\ C\ E$ parameters).

If the reference channel or command channel is assigned to a fieldbus, when the supply mains is connected, the drive displays **[Freewheel]** $n\ 5\ E$. It remains in stop mode until the fieldbus gives a command.

Drive lock in blocking state

The drive is locked in a blocking state and displays **[Freewheel Stop]** $n\ 5\ E$, if a Run command such as Run forward, Run reverse, DC injection is still active during:

- A product reset to the factory settings,
- A manual "Fault Reset" using **[Fault Reset Assign]** $r\ 5\ F$,
- A manual "Fault reset" by applying a product switched off and on again,
- A stop command given by a channel that is not the active channel command (such as Stop key of the display terminal in 2/3 wires control),

It will be necessary to deactivate all active Run commands prior to authorizing a new Run command.

Option Module Changed or Removed

When an option module is removed or replaced by another, the drive locks in **[Incorrect configuration]** $C\ F\ F$ error mode at power-on. If the option module has been deliberately changed or removed, the detected error can be cleared by pressing the **OK** key twice, which causes the factory settings to be restored for the parameter groups affected by the option module.

Control Block Changed

When a control block is replaced by a control block configured on a drive with a different rating, the drive locks in **[Incorrect configuration]** $C\ F\ F$ error mode at power-on. If the control block has been deliberately changed, the detected error can be cleared by pressing the **OK** key twice, which **causes all the factory settings to be restored.**

Glossary

D

Display terminal :

The display terminal menus are shown in square brackets.

For example: **[Communication]**

The codes are shown in round brackets.

For example: **(C o P)** -

Parameter names are displayed on the display terminal in square brackets.

For example: **[Fallback Speed]**

Parameter codes are displayed in round brackets.

For example: **(L F F)**

E

Error :

Discrepancy between a detected (computed, measured, or signaled) value or condition and the specified or theoretically correct value or condition.

F

Factory setting:

Factory settings when the product is shipped

Fault Reset:

A function used to restore the drive to an operational state after a detected error is cleared by removing the cause of the error so that the error is no longer active.

Fault:

Fault is an operating state. If the monitoring functions detect an error, a transition to this operating state is triggered, depending on the error class. A "Fault reset" is required to exit this operating state after the cause of the detected error has been removed. Further information can be found in the pertinent standards such as IEC 61800-7, ODVA Common Industrial Protocol (CIP).

M

Monitoring function:

Monitoring functions acquire a value continuously or cyclically (for example, by measuring) in order to check whether it is within permissible limits. Monitoring functions are used for error detection.

P

Parameter:

Device data and values that can be read and set (to a certain extent) by the user.

PELV:

Protective Extra Low Voltage, low voltage with isolation. For more information: IEC 60364-4-41

PLC:

Programmable logic controller

Power stage:

The power stage controls the motor. The power stage generates current for controlling the motor.

W

Warning:

If the term is used outside the context of safety instructions, a warning alerts to a potential error that was detected by a monitoring function. A warning does not cause a transition of the operating state.

Schneider Electric
35 rue Joseph Monier
92500 Rueil Malmaison
France

+ 33 (0) 1 41 29 70 00

www.se.com

As standards, specifications, and design change from time to time,
please ask for confirmation of the information given in this publication.

© 2022 Schneider Electric. All rights reserved.

EAV64318.10