



## Main

Range of Product	Modicon STB distributed I/O solution
Product or Component Type	Standard digital input kit
Kit composition	STBXTS2100, 6-terminal spring clamp connector STBDDI3420 module STBXTS1100, 6-terminal screw type connector STBXBA1000 base
Discrete input number	4
Discrete input voltage	24 V
Discrete input voltage type	DC

## Complementary

Input voltage limits	11...30 V at state 1 -3...5 V at state 0
Acceptable Input Voltage	30 V
Absolute maximum voltage	56 V 1.3 ms
Discrete input current	8 mA
Current state 0 guaranteed	<= 1.2 mA
Current state 1 guaranteed	>= 2.5 mA
Discrete input logic	Positive or negative
Response time	0.925 ms off-to-on 0.5 ms 1.35 ms on-to-off 0.5 ms
Protection type	Power protection integrated fuse on PDM time lag 10 A Input protection resistor-limited Reverse polarity protection
Insulation between channels and logic bus	1500 V for 1 minute
Cold swapping	Yes
Hot swapping	Yes for standard NIMs
Input filtering	1 ms 2 ms 4 ms 8 ms 0.5 ms 16 ms +/- 0.25 ms
Current supplied by sensor	100 mA per channel
Product Compatibility	I/O base STBXBA1000 Power distribution module STBPDT3100/3105
[Us] rated supply voltage	24 V DC
Supply	Power distribution module
Current consumption	45 mA 5 V DC logic bus
Marking	CE
Overvoltage category	II
Status LED	1 LED (Green) module status (RDY) 1 LED per channel (Green) channel status (IN1 to IN4) 1 LED (Red) module error (ERR)
Depth	2.56 in (65.1 mm)
Height	0.72 in (18.4 mm)
Width	4.92 in (125 mm)
Net Weight	0.24 lb(US) (0.111 kg)

The information provided in this documentation contains general descriptions and/or technical characteristics of the performance of the products contained herein. This documentation is not intended as a substitute for and is not to be used for determining suitability or reliability of these products for specific user applications. It is the duty of any such user or integrator to perform the appropriate and complete risk analysis, evaluation and testing of the products with respect to the relevant specific application or use thereof. Neither Schneider Electric Industries SAS nor any of its affiliates or subsidiaries shall be responsible or liable for misuse of the information contained herein.

## Environment

Standards	EN/IEC 61131-2type 1+
Product Certifications	CSA FM Class 1 Division 2 UL
Pollution degree	2 IEC 60664-1
Operating altitude	<= 6561.68 ft (2000 m)
IP degree of protection	IP20 conforming to EN 61131-2 class 1
Ambient air temperature for operation	-13...158 °F (-25...70 °C) without derating)
Ambient air temperature for operation	32...140 °F without derating
Ambient air temperature for storage	-40...185 °F (-40...85 °C) without derating
Ambient air temperature for storage	-40...185 °F without derating
Relative humidity	95 % 140 °F (60 °C) without condensation
Vibration resistance	3 gn 58...150 Hz 35 x 7.5 mm symmetrical DIN rail 5 gn 58...150 Hz 35 x 15 mm symmetrical DIN rail +/-0.35 mm 10...58 Hz
Shock resistance	30 gn 11 ms IEC 88 reference 2-27



## Ordering and shipping details

Category	18215-ADVANTYS STB I/O
Discount Schedule	PC32
GTIN	3595863948905
Returnability	No
Country of origin	ID

## Packing Units

Unit Type of Package 1	PCE
Number of Units in Package 1	1
Package 1 Height	0.98 in (2.5 cm)
Package 1 Width	3.15 in (8.0 cm)
Package 1 Length	5.12 in (13.0 cm)
Package 1 Weight	4.62 oz (131.0 g)
Unit Type of Package 2	S02
Number of Units in Package 2	28
Package 2 Height	5.91 in (15.0 cm)
Package 2 Width	11.81 in (30.0 cm)
Package 2 Length	15.75 in (40.0 cm)
Package 2 Weight	9.03 lb(US) (4.094 kg)
Unit Type of Package 3	PAL
Number of Units in Package 3	448
Package 3 Height	23.62 in (60.0 cm)
Package 3 Width	31.50 in (80.0 cm)
Package 3 Length	176.38 in (448.0 cm)
Package 3 Weight	131.36 lb(US) (59.584 kg)

## Offer Sustainability

Sustainable offer status	Green Premium product
California proposition 65	WARNING: This product can expose you to chemicals including: Lead and lead compounds, which is known to the State of California to cause cancer and birth defects or other reproductive harm. For more information go to <a href="http://www.P65Warnings.ca.gov">www.P65Warnings.ca.gov</a>
REACH Regulation	 <a href="#">REACH Declaration</a>
EU RoHS Directive	Pro-active compliance (Product out of EU RoHS legal scope)  <a href="#">EU RoHS Declaration</a>
Mercury free	Yes

China RoHS Regulation	<a href="#">China RoHS Declaration</a>
RoHS exemption information	<a href="#">Yes</a>
Environmental Disclosure	<a href="#">Product Environmental Profile</a>
Circularity Profile	<a href="#">End Of Life Information</a>
WEEE	The product must be disposed on European Union markets following specific waste collection and never end up in rubbish bins.

### Contractual warranty

Warranty	18 months
----------	-----------

## Dimensions

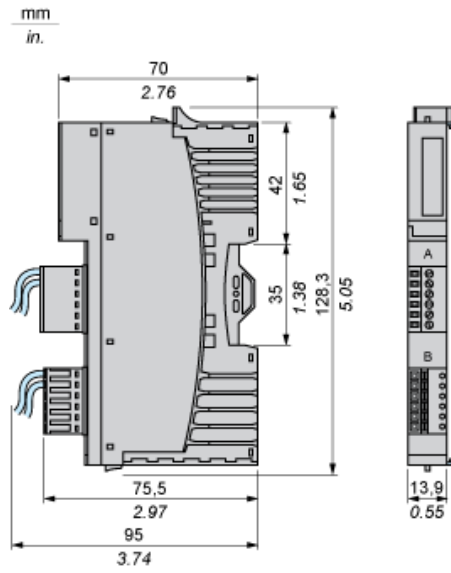

Wiring Diagram

Example

2 three-wire sensor and 2 two-wire sensor

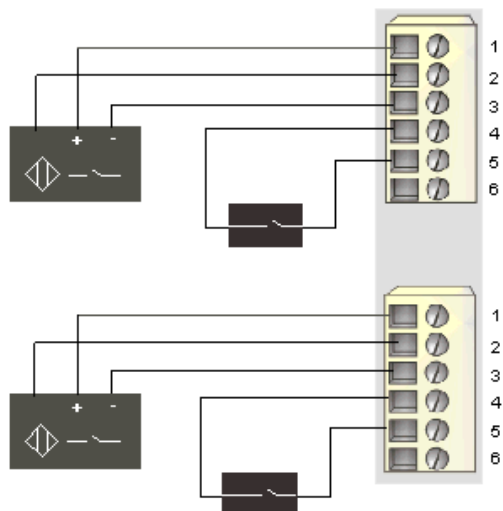

Pin	Top Connector	Bottom Connector
1	+24 VDC from sensor bus for field device accessories	+24 VDC from sensor bus for field device accessories
2	input from sensor 1	input from sensor 3
3	field power return (to the module)	field power return (to the module)
4	+24 VDC from sensor bus for field device accessories	+24 VDC from sensor bus for field device accessories
5	input from sensor 2	input from sensor 4
6	field power return (to the module)	field power return (to the module)