

TeSys DFB Library V2 for Unity Pro

a SoCollaborative library
User Manual



01/2020

The information provided in this documentation contains general descriptions and/or technical characteristics of the performance of the products contained herein. This documentation is not intended as a substitute for and is not to be used for determining suitability or reliability of these products for specific user applications. It is the duty of any such user or integrator to perform the appropriate and complete risk analysis, evaluation and testing of the products with respect to the relevant specific application or use thereof. Neither Schneider Electric nor any of its affiliates or subsidiaries shall be responsible or liable for misuse of the information contained herein. If you have any suggestions for improvements or amendments or have found errors in this publication, please notify us.

You agree not to reproduce, other than for your own personal, noncommercial use, all or part of this document on any medium whatsoever without permission of Schneider Electric, given in writing. You also agree not to establish any hypertext links to this document or its content. Schneider Electric does not grant any right or license for the personal and noncommercial use of the document or its content, except for a non-exclusive license to consult it on an "as is" basis, at your own risk. All other rights are reserved.

All pertinent state, regional, and local safety regulations must be observed when installing and using this product. For reasons of safety and to help ensure compliance with documented system data, only the manufacturer should perform repairs to components.

When devices are used for applications with technical safety requirements, the relevant instructions must be followed.

Failure to use Schneider Electric software or approved software with our hardware products may result in injury, harm, or improper operating results.

Failure to observe this information can result in injury or equipment damage.

© 2020 Schneider Electric. All rights reserved.

Table of Contents



	Safety Information	5
	About the Book	9
Chapter 1	Introduction	11
	Presentation	12
	TeSys DFB Library Overview	13
	TeSys DFB Sequencing	17
Chapter 2	Modbus SL DFB	21
	Ctrl_cmd_mdb_u_****: TeSys U Control/Command for Modbus SL	22
	Comm_manager_u: TeSys U Communication Management for Modbus SL	26
	Ctrl_cmd_mdb_t_****: TeSys T Control/Command for Modbus SL	30
	Comm_manager_t: TeSys T Communication Management for Modbus SL	34
Chapter 3	Modbus SL and Modbus/TCP DFB	39
	Special_mdb_u_****: TeSys U DFB for Modbus SL and Modbus/TCP	40
	Special_mdb_t_****: TeSys T DFB for Modbus SL and Modbus/TCP	46
	Custom_mdb_****: Custom Read DFB for Modbus SL and Modbus/TCP	58
Chapter 4	Modbus/TCP DFB for Quantum PLC	61
	Special_mdb_u_addq: TeSys U DFB for Modbus/TCP for Quantum PLC	62
	Special_mdb_t_addq: TeSys T DFB for Modbus/TCP for Quantum PLC	68
	Custom_mdb_addq: Custom Read DFB for Modbus/TCP for Quantum PLC	78
Chapter 5	Profibus DFB	81
	Ctrl_pfb_u_ms: TeSys U Control/Command for Profibus DP MS	82
	Ctrl_pfb_u_mms: TeSys U Control/Command for Profibus DP MMS	84
	Ctrl_pfb_t_mms: TeSys T Control/Command for Profibus DP MMS	86
Chapter 6	Cyclic Control/Command DFB	89
	Ctrl_cmd_u: TeSys U Cyclic Control/Command	90
	Ctrl_cmd_t: TeSys T Cyclic Control/Command	92
Chapter 7	PKW Exchanges DFB	95
	Special_pkw_u: TeSys U DFB for PKW Exchanges	96
	Special_pkw_t: TeSys T DFB for PKW Exchanges	102
	Custom_pkw: Custom Read DFB for PKW Exchanges	113
Chapter 8	Treatment DFB	117
	Scale: TeSys U DFB for Measurement Unit Conversion	118
	Timestamp_*: TeSys U DFB for Data Time-Stamping	120



Important Information

NOTICE

Read these instructions carefully, and look at the equipment to become familiar with the device before trying to install, operate, service, or maintain it. The following special messages may appear throughout this documentation or on the equipment to warn of potential hazards or to call attention to information that clarifies or simplifies a procedure.



The addition of this symbol to a “Danger” or “Warning” safety label indicates that an electrical hazard exists which will result in personal injury if the instructions are not followed.



This is the safety alert symbol. It is used to alert you to potential personal injury hazards. Obey all safety messages that follow this symbol to avoid possible injury or death.

DANGER

DANGER indicates a hazardous situation which, if not avoided, **will result in** death or serious injury.

WARNING

WARNING indicates a hazardous situation which, if not avoided, **could result in** death or serious injury.

CAUTION

CAUTION indicates a hazardous situation which, if not avoided, **could result in** minor or moderate injury.

NOTICE

NOTICE is used to address practices not related to physical injury.

PLEASE NOTE

Electrical equipment should be installed, operated, serviced, and maintained only by qualified personnel. No responsibility is assumed by Schneider Electric for any consequences arising out of the use of this material.

A qualified person is one who has skills and knowledge related to the construction and operation of electrical equipment and its installation, and has received safety training to recognize and avoid the hazards involved.

BEFORE YOU BEGIN

Do not use this product on machinery lacking effective point-of-operation guarding. Lack of effective point-of-operation guarding on a machine can result in serious injury to the operator of that machine.

WARNING

UNGUARDED EQUIPMENT

- Do not use this software and related automation equipment on equipment which does not have point-of-operation protection.
- Do not reach into machinery during operation.

Failure to follow these instructions can result in death, serious injury, or equipment damage.

This automation equipment and related software is used to control a variety of industrial processes. The type or model of automation equipment suitable for each application will vary depending on factors such as the control function required, degree of protection required, production methods, unusual conditions, government regulations, etc. In some applications, more than one processor may be required, as when backup redundancy is needed.

Only you, the user, machine builder or system integrator can be aware of all the conditions and factors present during setup, operation, and maintenance of the machine and, therefore, can determine the automation equipment and the related safeties and interlocks which can be properly used. When selecting automation and control equipment and related software for a particular application, you should refer to the applicable local and national standards and regulations. The National Safety Council's Accident Prevention Manual (nationally recognized in the United States of America) also provides much useful information.

In some applications, such as packaging machinery, additional operator protection such as point-of-operation guarding must be provided. This is necessary if the operator's hands and other parts of the body are free to enter the pinch points or other hazardous areas and serious injury can occur. Software products alone cannot protect an operator from injury. For this reason the software cannot be substituted for or take the place of point-of-operation protection.

Ensure that appropriate safeties and mechanical/electrical interlocks related to point-of-operation protection have been installed and are operational before placing the equipment into service. All interlocks and safeties related to point-of-operation protection must be coordinated with the related automation equipment and software programming.

NOTE: Coordination of safeties and mechanical/electrical interlocks for point-of-operation protection is outside the scope of the Function Block Library, System User Guide, or other implementation referenced in this documentation.

START-UP AND TEST

Before using electrical control and automation equipment for regular operation after installation, the system should be given a start-up test by qualified personnel to verify correct operation of the equipment. It is important that arrangements for such a check be made and that enough time is allowed to perform complete and satisfactory testing.

WARNING

EQUIPMENT OPERATION HAZARD

- Verify that all installation and set up procedures have been completed.
- Before operational tests are performed, remove all blocks or other temporary holding means used for shipment from all component devices.
- Remove tools, meters, and debris from equipment.

Failure to follow these instructions can result in death, serious injury, or equipment damage.

Follow all start-up tests recommended in the equipment documentation. Store all equipment documentation for future references.

Software testing must be done in both simulated and real environments.

Verify that the completed system is free from all short circuits and temporary grounds that are not installed according to local regulations (according to the National Electrical Code in the U.S.A, for instance). If high-potential voltage testing is necessary, follow recommendations in equipment documentation to prevent accidental equipment damage.

Before energizing equipment:

- Remove tools, meters, and debris from equipment.
- Close the equipment enclosure door.

-
- Remove all temporary grounds from incoming power lines.
 - Perform all start-up tests recommended by the manufacturer.

OPERATION AND ADJUSTMENTS

The following precautions are from the NEMA Standards Publication ICS 7.1-1995 (English version prevails):

- Regardless of the care exercised in the design and manufacture of equipment or in the selection and ratings of components, there are hazards that can be encountered if such equipment is improperly operated.
- It is sometimes possible to misadjust the equipment and thus produce unsatisfactory or unsafe operation. Always use the manufacturer's instructions as a guide for functional adjustments. Personnel who have access to these adjustments should be familiar with the equipment manufacturer's instructions and the machinery used with the electrical equipment.
- Only those operational adjustments actually required by the operator should be accessible to the operator. Access to other controls should be restricted to prevent unauthorized changes in operating characteristics.

About the Book



At a Glance

Document Scope

This manual describes the DFB (Derived Function Block) library dedicated to TeSys U starter-controllers and TeSys T motor management systems.

It is intended for design engineers and system integrators who have a good knowledge of Unity Pro PLC programming platforms.

The purposes of this manual are to

- describe the scope of the DFB library and platform compatibility,
- describe the DFB characteristics and the download procedure from the Schneider Electric website,
- explain how to implement the DFB in the PLC application.

Validity Note

This TeSys library is compatible and usable with the following versions of Unity Pro:

- Unity Pro V2.3 SP2
- Unity Pro V3.0
- Unity Pro V3.1
- Unity Pro V4.0 or later

This manual is valid for all TeSys DFBs. The following table describes the differences between versions 1 and 2 of Unity Pro:

Library Version	Date	Evolution
V1	03/2009	Initial version
V2	09/2009	Addition of 3 new DFBs for Quantum PLC: <ul style="list-style-type: none">• Special_mdb_u_addq• Special_mdb_t_addq• Custom_mdb_addq Evolution of 2 existing DFBs to be compatible with Quantum PLC: <ul style="list-style-type: none">• Ctrl_cmd_u• Ctrl_cmd_t

Related Documents

Title of Documentation	Reference Number
TeSys U LUCM and LUCMT Multifunction Control Unit User Manual	1743237
TeSys U Communication Variables User Manual	1744082
TeSys U LULC032-033 Modbus Communication Module User Manual	1743234
TeSys U LULC15 Advantys STB Communication Module User Manual	1744083
TeSys U LULC08 CANopen Communication Module User Manual	1744084
TeSys U LULC07 Profibus DP Communication Module User Manual	1672610
TeSys T LTMR Motor Management Controller - User Guide	DOCA0127
TeSys T LTMR Ethernet Communication Guide	DOCA0129
TeSys T LTMR Modbus Communication Guide	DOCA0130
TeSys T LTMR PROFIBUS DP Communication Guide	DOCA0131
TeSys T LTMR CANopen Communication Guide	DOCA0132
LAD9AP3•• Quickfit Instruction Sheet	1568984
LUFC00 Parallel Wiring Module Instruction Sheet	1743239
LU9G02 Splitter Box Instruction Sheet	1638822
LU9G03 Splitter Box Instruction Sheet	AAV90641

You can download these technical publications and other technical information from our website at <https://www.se.com/ww/en/download/> .

Chapter 1

Introduction

Introduction

This chapter gives an overview of the TeSys U and TeSys T DFB (Derived Function Block) library, presents the DFB library download procedure from the Schneider Electric website, and describes the sequencing system used to synchronize the treatment between DFBs.

What Is in This Chapter?

This chapter contains the following topics:

Topic	Page
Presentation	12
TeSys DFB Library Overview	13
TeSys DFB Sequencing	17

Presentation

Aim of the TeSys DFB Library

The TeSys DFB library has been developed to simplify and optimize the integration of TeSys U starter-controllers and TeSys T motor management systems in PLC applications, for both PLC programmers and end users.

The TeSys DFB library for Unity Pro can be ordered with part number UNYLTSZFUWB.

Advantages for the PLC Programmer

The TeSys DFB library enables the PLC programmer to

- simplify the program design: the program is split by functions (control, command, data treatment,...),
- optimize the programming time: the DFB is tested and can be re-used for different applications,
- increase the program understanding: the applications are coded in the same way using the common DFB,
- optimize the program size: the same code is used for each DFB instantiation,
- simplify the TeSys U and TeSys T integration: the data mapping management is masked.

Advantages for the End User

The TeSys DFB library enables the end user to

- optimize the communication response time:
 - the Modbus requests management is optimized,
 - the data exchange management is optimized,
 - the product performance is taken into account,
- have a functional view of the motor-starter by providing direct access to common functions (Ready, Alarm, Run, Stop,...),
- group data related to a specific application (diagnostic, maintenance, measurement,...) through a program number,
- facilitate debugging: variables used by the DFB are identified on its interface.

PLC Platform Compatibility

The TeSys DFB library can be integrated in the Unity Pro programming platform with Quantum, Premium and M340 PLC platforms.

TeSys Compatibility

The TeSys DFB library for Unity Pro is compatible with:

- TeSys U starter-controllers (up to 38 A/18.5 kW or 25 hp),
- TeSys T motor management system.

Communication Protocol Compatibility

The following table describes the TeSys DFB library compatibility with communication protocols and the corresponding TeSys U and TeSys T assemblies.

Protocol	TeSys U	TeSys T
Modbus SL (Serial Line)	Starter-controller with LULC033 Modbus communication module	LTMR••M•• Modbus SL controller with or without the LTM E expansion module
Modbus/TCP	Starter-controller with LULC033 Modbus communication module and Ethernet gateway (TeSysPort, TSXETG100, TSXETG1000,...)	LTMR••E•• Modbus/TCP controller with or without the LTM E expansion module
Profibus DP	Starter-controller with LULC07 Profibus DP communication module	LTMR••P•• Profibus DP controller with or without the LTM E expansion module
CANopen	Starter-controller with LULC08 CANopen communication module	LTMR••C•• CANopen controller with or without the LTM E expansion module
Advantys STB with communication module	Starter-controller with LULC15 Advantys STB communication module	–

TeSys DFB Library Overview

TeSys DFB Library Organization

The following table lists the TeSys DFB library according to the communication protocol and service and their availability according to the TeSys model:

Communication Protocol / Service	DFB Name	TeSys U up to 32 A	TeSys U up to 38 A	TeSys T
Modbus SL	Ctrl_cmd_mdb_u_****	√	√	–
	Comm_manager_u	√	√	–
	Ctrl_cmd_mdb_t_****	–	–	√
	Comm_manager_t	–	–	√
Modbus SL and Modbus/TCP	Custom_mdb_****	√	–	√
	Special_mdb_u_****	√	–	–
	Special_mdb_t_****	–	–	√
Modbus/TCP (for Quantum PLC)	Custom_mdb_addq	√	–	√
	Special_mdb_u_addq	√	–	–
	Special_mdb_t_addq	–	–	√
Profibus DP	Ctrl_pfb_u_ms	√	√	–
	Ctrl_pfb_u_mms	√	–	–
	Ctrl_pfb_t_mms	–	–	√
Cyclic control/command (Modbus/TCP (IO scanning), CANopen, and Advantys STB)	Ctrl_cmd_u (Modbus/TCP (IO scanning), CANopen, and Advantys STB)	√	√	–
	Ctrl_cmd_t (Modbus/TCP (IO scanning) and CANopen)	–	–	√
PKW	Special_pkw_u	√	–	–
	Special_pkw_t	–	–	√
	Custom_pkw	√	–	√
Treatment	Timestamp_•	√	–	–
	Scale	√	–	–

Modbus SL DFB Library

The following table describes the Modbus SL (Serial Line) DFB library:

DFB	Description	For More Information
Ctrl_cmd_mdb_u_addr Ctrl_cmd_mdb_u_addm	<p>These DFBs are dedicated to the control and command of a single TeSys U starter-controller with any control unit and a LULC033 Modbus communication module.</p> <ul style="list-style-type: none"> ● Ctrl_cmd_mdb_u_addr is dedicated to Premium PLC. ● Ctrl_cmd_mdb_u_addm is dedicated to M340 PLC. <p>These DFBs enable the user to</p> <ul style="list-style-type: none"> ● read status register 455, ● write command register 704, ● reset communication loss (register 703, bit 3). <p>The program number enables the user to select bit or word control.</p>	<i>Ctrl_cmd_mdb_u_****: TeSys U Control/Command for Modbus SL, page 22</i>
Comm_manager_u	<p>This DFB is dedicated to the control and command of up to 31 TeSys U starter-controllers with any control unit and a LULC033 Modbus communication module.</p> <p>It must be associated with the Ctrl_cmd_mdb_u_**** DFBs to manage the Modbus requests sequencing.</p> <p>It enables the user to</p> <ul style="list-style-type: none"> ● optimize the response time by taking into account the response time of the devices, ● send write requests only when necessary, ● manage the disconnection and reconnection of a TeSys U Modbus slave. <p>The program number enables the user to select different Modbus request sequences.</p>	<i>Comm_manager_u: TeSys U Communication Management for Modbus SL, page 26</i>

DFB	Description	For More Information
Ctrl_cmd_mdb_t_addr Ctrl_cmd_mdb_t_addm	<p>These DFBs are dedicated to the control and command of a single TeSys T LTMR••M•• Modbus SL controller with or without the LTM E expansion module.</p> <ul style="list-style-type: none"> ● Ctrl_cmd_mdb_t_addr is dedicated to Premium PLC. ● Ctrl_cmd_mdb_t_addm is dedicated to M340 PLC. <p>These DFBs enable the user to</p> <ul style="list-style-type: none"> ● read status registers 455 and 456, ● write command register 704. <p>The program number enables the user to select bit or word control.</p>	<i>Ctrl_cmd_mdb_t_****: TeSys T Control/Command for Modbus SL, page 30</i>
Comm_manager_t	<p>This DFB is dedicated to the control and command of several TeSys T LTMR••M•• Modbus SL controllers with or without the LTM E expansion module. It must be associated with the Ctrl_cmd_mdb_t_**** DFBs to manage the Modbus requests sequencing.</p> <p>It enables the user to</p> <ul style="list-style-type: none"> ● optimize the response time by taking into account the response time of the devices, ● send write requests only when necessary, ● manage the disconnection and reconnection of a TeSys U Modbus slave. <p>The program number enables the user to select different Modbus requests sequences.</p>	<i>Comm_manager_t: TeSys T Communication Management for Modbus SL, page 34</i>

Modbus SL and Modbus/TCP Library

The following table describes the Modbus SL and Modbus/TCP library:

DFB	Description	For More Information
Special_mdb_u_addr Special_mdb_u_addm	<p>These DFBs are dedicated to the reading of up to 16 predefined registers (diagnostic, maintenance, measurement,...) of a TeSys U starter-controller (up to 32 A/15 kW or 20 hp) with a LUCM multifunction control unit and a LULC033 Modbus communication module.</p> <p>The program number enables the user to select the predefined registers.</p> <ul style="list-style-type: none"> ● Special_mdb_u_addr is dedicated to Premium PLC and can be used with a TeSys U starter-controller connected on Modbus Serial Line or through a Modbus/TCP gateway. ● Special_mdb_u_addm is dedicated to M340 PLC and can be used with a TeSys U starter-controller connected on Modbus Serial Line or through a Modbus/TCP gateway. 	<i>Special_mdb_u_****: TeSys U DFB for Modbus SL and Modbus/TCP, page 40</i>
Special_mdb_t_addr Special_mdb_t_addm	<p>These DFBs are dedicated to the reading of up to 16 predefined registers (diagnostic, maintenance, measurement,...) of a TeSys T Modbus SL controller or TeSys T Modbus/TCP controller with or without the LTM E expansion module.</p> <p>The program number enables the user to select the predefined registers.</p> <ul style="list-style-type: none"> ● Special_mdb_t_addr is dedicated to Premium PLC and can be used with a TeSys T controller LTMR••M•• connected through Modbus Serial Line or a TeSys T controller LTMR••E•• through a Modbus/TCP network. ● Special_mdb_t_addm is dedicated to M340 PLC and can be used with a TeSys T controller LTMR••M•• connected through Modbus Serial Line or a TeSys T controller LTMR••E•• through a Modbus/TCP network. 	<i>Special_mdb_t_****: TeSys T DFB for Modbus SL and Modbus/TCP, page 46</i>
Custom_mdb_addr Custom_mdb_addm	<p>These DFBs are dedicated to the reading of up to 5 sets of registers in one single TeSys device.</p> <p>A set of registers is defined by the address of the first register to read and the length of the set (up to 16 registers per set).</p> <ul style="list-style-type: none"> ● Custom_mdb_addr is dedicated to Premium PLC and can be used with a TeSys connected through Modbus Serial Line or through a Modbus/TCP network. ● Custom_mdb_addm is dedicated to M340 PLC and can be used with a TeSys connected through Modbus Serial Line or through a Modbus/TCP network. 	<i>Custom_mdb_****: Custom Read DFB for Modbus SL and Modbus/TCP, page 58</i>

Modbus/TCP Quantum Library

The following table describes the Modbus/TCP DFB library dedicated to Quantum PLC:

DFB	Description	For More Information
Special_mdb_u_addq	This DFB is dedicated to the reading of up to 16 predefined registers (diagnostic, maintenance, measurement,...) in a TeSys U starter-controller (up to 32 A/15 kW or 20 hp) with a LUCM multifunction control unit and a LULC033 Modbus communication module through a Modbus/TCP gateway connected to a Quantum PLC. The program number enables the user to select the predefined registers.	<i>Special_mdb_u_addq: TeSys U DFB for Modbus/TCP for Quantum PLC, page 62</i>
Special_mdb_t_addq	This DFB is dedicated to the reading of up to 16 predefined registers (diagnostic, maintenance, measurement,...) in a TeSys T Modbus/TCP LTMR**E** controller with or without the LTM E expansion module connected to a Quantum PLC. The program number enables the user to select the predefined registers.	<i>Special_mdb_t_addq: TeSys T DFB for Modbus/TCP for Quantum PLC, page 68</i>
Custom_mdb_addq	This DFB is dedicated to the reading of up to 5 sets of registers in one single TeSys device connected through Modbus/TCP to a Quantum PLC. A set of registers is defined by the address of the first register to read and the length of the set (up to 16 registers per set).	<i>Custom_mdb_addq: Custom Read DFB for Modbus/TCP for Quantum PLC, page 78</i>

Profibus DP DFB Library

The following table describes the Profibus DP DFB library:

DFB	Description	For More Information
Ctrl_pfb_u_ms	This DFB is dedicated to the control and command of a single TeSys U starter-controller with any control unit and a LULC07 Profibus DP communication module using the Motor Starter profile.	<i>Ctrl_pfb_u_ms: TeSys U Control/Command for Profibus DP MS, page 82</i>
Ctrl_pfb_u_mms	This DFB is dedicated to the control and command of a single TeSys U starter-controller (up to 32 A/15 kW or 20 hp) with a LUCM multifunction control unit and a LULC07 Profibus DP communication module using the Motor Management Starter profile.	<i>Ctrl_pfb_u_mms: TeSys U Control/Command for Profibus DP MMS, page 84</i>
Ctrl_pfb_t_ms	This DFB is dedicated to the control and command of a single TeSys T LTMR**P** Profibus controller with or without the LTM E expansion module.	<i>Ctrl_pfb_t_mms: TeSys T Control/Command for Profibus DP MMS, page 86</i>

Cyclic Control/Command DFB Library

The following table describes the cyclic control/command (Modbus/TCP (IO scanning), CANopen, and Advantys STB) DFB library:

DFB	Description	For More Information
Ctrl_cmd_u	This DFB is dedicated to the control and command of a single TeSys U starter-controller with any control unit and a LULC08 CANopen, a LULC15 STB communication module, or a LULC033 Modbus communication module with an Ethernet gateway.	<i>Ctrl_cmd_u: TeSys U Cyclic Control/Command, page 90</i>
Ctrl_cmd_t	This DFB is dedicated to the control and command of a single TeSys T LTMR**C** CANopen controller or a TeSys T LTMR**E** Modbus/TCP controller, with or without the LTM E expansion module.	<i>Ctrl_cmd_t: TeSys T Cyclic Control/Command, page 92</i>

PKW DFB Library

The following table describes the PKW DFB library:

DFB	Description	For More Information
Special_pkw_u	<p>This DFB is dedicated to the reading of up to 16 predefined registers (diagnostic, maintenance, measurement,...) of a single TeSys U starter-controller (up to 32 A/15 kW or 20 hp) with a LUCM multifunction control unit and one of the following communication modules that support PKW exchanges:</p> <ul style="list-style-type: none"> ● LULC07 (Profibus DP) ● LULC08 (CANopen) ● LULC15 (Advantys STB) <p>The program number enables the user to select the predefined registers.</p>	<i>Special_pkw_u: TeSys U DFB for PKW Exchanges, page 96</i>
Special_pkw_t	<p>This DFB is dedicated to the reading of up to 16 predefined registers (diagnostic, maintenance, measurement,...) of a single TeSys T LTMR••P•• Profibus controller or a LTMR••C•• CANopen controller with or without the LTM E expansion module.</p> <p>The program number enables the user to select the predefined registers.</p>	<i>Special_pkw_t: TeSys T DFB for PKW Exchanges, page 102</i>
Custom_pkw	<p>This DFB is dedicated to the reading of up to 5 sets of registers of a single TeSys device supporting PKW exchanges.</p> <p>A set of registers is defined by the address of the first register to read and the length of the set (up to 16 registers per set).</p>	<i>Custom_pkw: Custom Read DFB for PKW Exchanges, page 113</i>

Treatment DFB Library

The following table describes the treatment DFB library:

DFB	Description	For More Information
Scale	<p>This DFB is dedicated to the conversion of current measurement unit from relative value (% FLA) to Amps for a TeSys U starter-controller (up to 32 A/15 kW or 20 hp) with a LUCM multifunction control unit. It also enables the user to select another unit in the A...mA range.</p>	<i>Scale: TeSys U DFB for Measurement Unit Conversion, page 118</i>
Timestamp Timestamp_q	<p>These DFBs are dedicated to the time-stamping of up to 8 input registers of a TeSys U starter-controller (up to 32 A/15 kW or 20 hp) with a LUCM multifunction control unit. It provides an output table of the 8 time-stamped registers and 4 date and time registers.</p> <ul style="list-style-type: none"> ● Timestamp is dedicated to Premium and M340 PLCs ● Timestamp_q is dedicated to Quantum PLC. 	<i>Timestamp_*: TeSys U DFB for Data Time-Stamping, page 120</i>

TeSys DFB Sequencing

Introduction

Some of the TeSys DFBs use a sequencing system using dedicated inputs and outputs that enable the sequencing and the synchronization of the treatment between DFBs.

The following derived function blocks use a sequencing system:

- Ctrl_cmd_mdb_u_....
- Ctrl_cmd_mdb_t_....
- Special_mdb_u_....
- Special_mdb_t_....
- Custom_mdb_....
- Special_pkw_u
- Special_pkw_t
- Custom_pkw
- Timestamp_•

Sequencing System Principle

The sequencer has 2 boolean inputs and 3 boolean outputs:

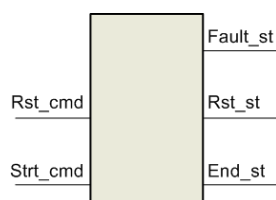

- The **_cmd** suffix indicates a command dedicated to the DFB sequencer function.
- The **_st** suffix indicates a status information concerning the DFB sequencer function.

The following table describes the sequencer inputs and outputs:

Input/Output	Description
Rst_cmd	This command resets the DFB and/or restarts the DFB treatment if Strt_cmd is set to 1.
Strt_cmd	This command starts the DFB treatment.
Fault_st	This status bit indicates <ul style="list-style-type: none"> • a parameterization error (value out of range), • a communication fault. If a fault occurs, the applicative boolean outputs are reset to 0, and the output words are forced to -1.
Rst_st	This status bit indicates <ul style="list-style-type: none"> • a reset in progress, • a treatment in progress.
End_st	This status bit indicates the end of the DFB treatment.

Stand-Alone with Manual Restart

In the stand-alone with manual restart configuration, the DFB is not linked to another DFB and it is activated each time %M0 is set to 1:

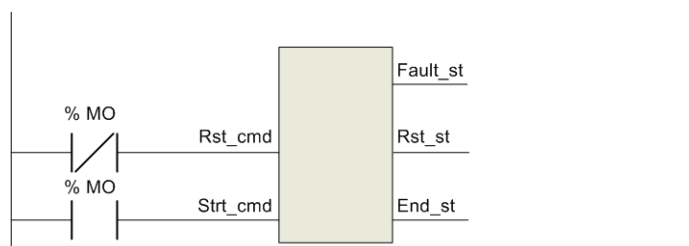

Stand-Alone with Automatic Restart

In the stand-alone with automatic restart configuration, the DFB is not linked to another DFB and it is activated continuously when %M0 is set to 1:

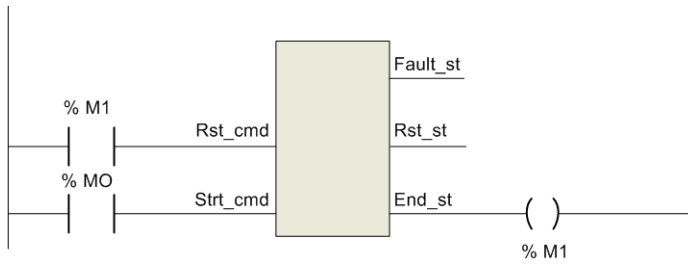

DFB Chaining with Manual Restart

In the DFB chaining with manual restart configuration, the DFB is linked to other DFBs and it is activated each time %M0 is set to 1:

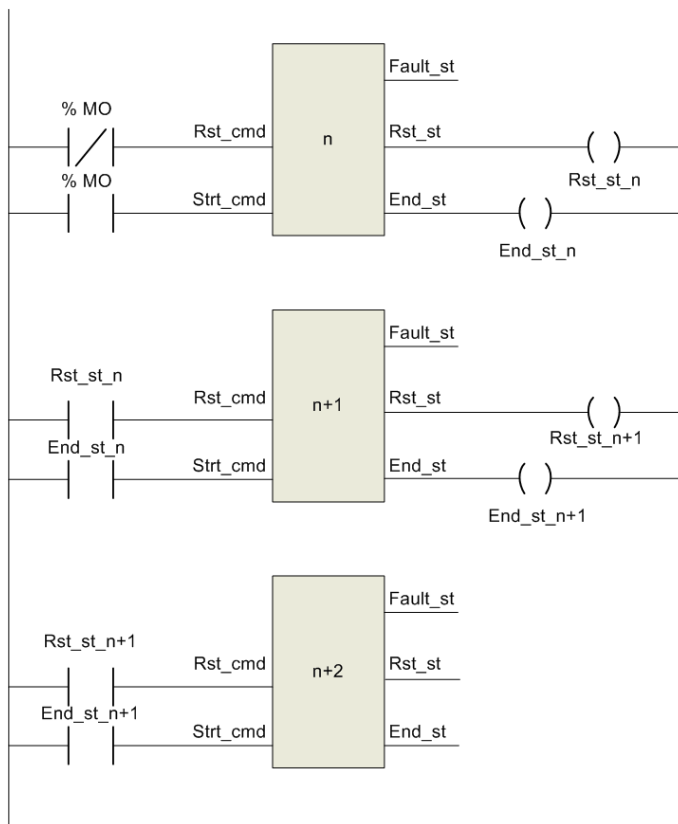

DFB Chaining with Automatic Restart

In the DFB chaining with automatic restart configuration, the DFB is linked to other DFBs and it is activated continuously when %M0 is set to 1:

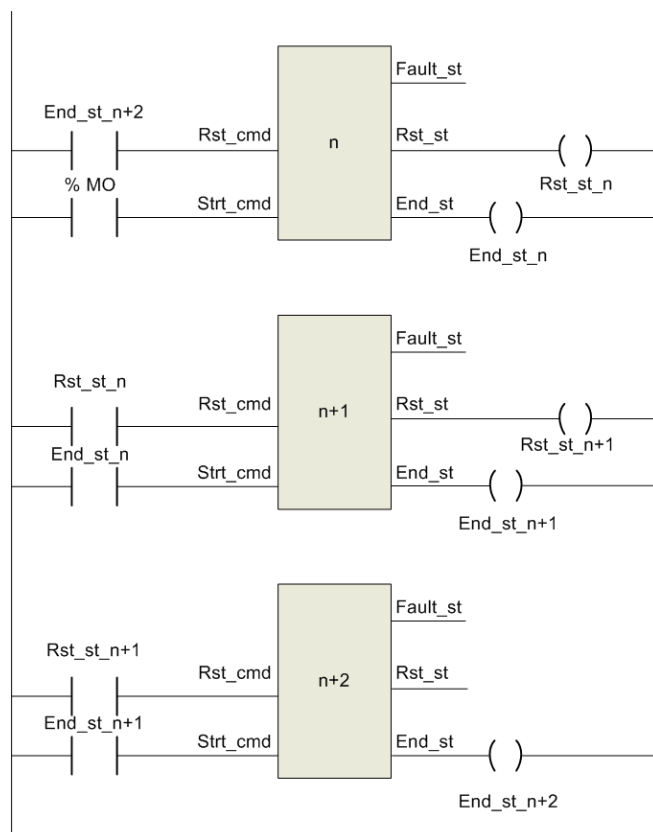

Chapter 2

Modbus SL DFB

Introduction

This chapter describes the TeSys U and TeSys T Modbus SL (Serial Line) DFBs.

What Is in This Chapter?

This chapter contains the following topics:

Topic	Page
Ctrl_cmd_mdb_u_****: TeSys U Control/Command for Modbus SL	22
Comm_manager_u: TeSys U Communication Management for Modbus SL	26
Ctrl_cmd_mdb_t_****: TeSys T Control/Command for Modbus SL	30
Comm_manager_t: TeSys T Communication Management for Modbus SL	34

Ctrl_cmd_mdb_u_****: TeSys U Control/Command for Modbus SL

Presentation

The Ctrl_cmd_mdb_u_**** DFBs are dedicated to the control and command of a single TeSys U starter-controller with any control unit and a LULC033 Modbus communication module through the Modbus SL (Serial Line) network.

- Ctrl_cmd_mdb_u_addr uses XWAY addressing and is dedicated to Premium PLCs.
- Ctrl_cmd_mdb_u_addm uses an addressing method dedicated to M340 PLCs.

For more information, see the *TeSys U LULC032-033 Modbus Communication Module User Manual*.

Characteristics

Characteristic	Value	
Name	Ctrl_cmd_mdb_u_addr	Ctrl_cmd_mdb_u_addm
Version	1.00	1.00
Input	11	11
Output	13	13
Input/Output	0	0
Public Variable	6	8

Graphical Representation

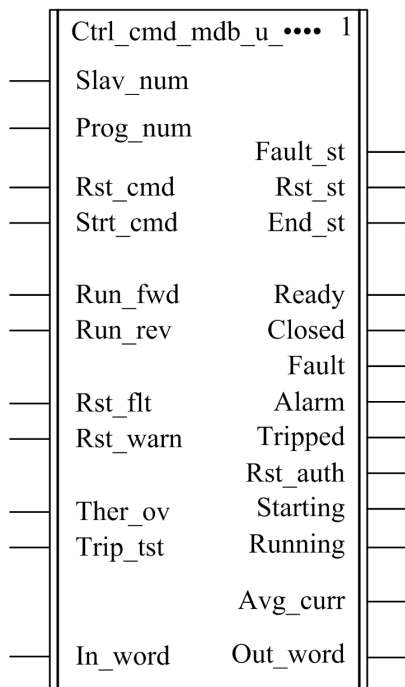

TeSys U Compliance

The Ctrl_cmd_mdb_u_**** DFBs are compliant with the following TeSys U sub-assemblies:

Power base	<ul style="list-style-type: none"> • LUB** non-reversing power base • LU2B** reversing power base
Control unit	<ul style="list-style-type: none"> • LUCA standard control unit • LUCB and LUCD advanced control units • LUCC advanced control unit (up to 32 A/15 kW or 20 hp) • LUCL magnetic control unit • LUCM multifunction control unit (up to 32 A/15 kW or 20 hp)
Communication module	<ul style="list-style-type: none"> • LULC033 Modbus communication module

Software Implementation

- The parameters and the inputs can only be changed if the End_st output variable is set to 1.
- The output data is only valid if the End_st output variable is set to 1 and if there is no fault detected (Fault_st = 0).

Input Characteristics

The following table describes the DFB inputs and their availability according to the control unit:

Input	Type	Range	Default Value	Description	LUCA LUCL	LUCB LUCC LUCD	LUCM
Slav_num	INT	1...31	1	Modbus slave number	√	√	√
Prog_num	INT	1...30	–	See <i>Program Number</i> , page 23	√	√	√
Rst_cmd	EBOOL	0...1	0	Reset command	√	√	√
Strt_cmd	EBOOL	0...1	0	Start command	√	√	√
Run_fwd	EBOOL	0...1	0	Motor run forward command	√	√	√
Run_rev	EBOOL	0...1	0	Motor run reverse command	√	√	√
Rstflt	EBOOL	0...1	0	Reset device (if register 451 = 102 or 104, fault acknowledgment causes a return to communication module factory settings)	√	√	√
Rst_warn	EBOOL	0...1	0	Reset warning (for example, communication loss)	√	√	√
Ther_ov	EBOOL	0...1	0	Automatic thermal overload fault test	–	–	√
Trip_tst	EBOOL	0...1	0	Overcurrent trip test via communication bus	–	–	√
In_word	INT	–	–	This input is only used when program number is 10, 20, or 30. See next table and program number description.	–	–	–

The following table describes the In_word input:

Input	Type	Bit	Description	LUCA LUCL	LUCB LUCC LUCD	LUCM
In_word	INT	0	Motor run forward command	√	√	√
		1	Motor run reverse command	√	√	√
		2	Reserved	–	–	–
		3	Reset device (if register 451 = 102 or 104, fault acknowledgment causes a return to communication module factory settings)	√	√	√
		4	Reserved	–	–	–
		5	Automatic thermal overload fault test	–	–	√
		6	Overcurrent trip test via communication bus	–	–	√
		7	Reserved	–	–	–
		8	Reset warning (for example, communication loss)	√	√	√
		9...15	Reserved	–	–	–

Program Number

The program number enables the user to select bit or word control.

The following table describes the programs of the DFB:

Program Number	Description
1	Read registers 455 and 456, then write register 704 (systematic)
2	Read registers 455 and 456, then write register 704 (conditional)
3	Write register 704
10	Same as program 1 but using the In_word input and the Out_word output
20	Same as program 2 but using the In_word input and the Out_word output
30	Same as program 3 but using the In_word input and the Out_word output

Output Characteristics

The following table describes the DFB outputs and their availability according to the control unit:

Output	Type	Range	Default Value	Description	LUCA LUCL	LUCB LUCC LUCD	LUCM
Fault_st	EBOOL	0...1	0	Fault detected	√	√	√
Rst_st	EBOOL	0...1	0	Reset state	√	√	√
End_st	EBOOL	0...1	0	End state	√	√	√
Ready	EBOOL	0...1	0	System ready: the rotary handle is turned to On position and there is no fault	√	√	√
Closed	EBOOL	0...1	0	Pole status: closed	√	√	√
Fault	EBOOL	0...1	0	All faults	√	√	√
Alarm	EBOOL	0...1	0	All warnings	√	√	√
Tripped	EBOOL	0...1	0	System tripped: the rotary handle is turned to Trip position	√	√	√
Rst_auth	EBOOL	0...1	0	Fault reset authorized	–	√	√
Starting	EBOOL	0...1	0	Start in progress: 0 = descending current is lower than 150% FLA 1 = ascending current is greater than 10% FLA	–	√	√
Running	EBOOL	0...1	0	Motor running with detection of current, if greater than 10% FLA	–	√	√
Avg_curr	INT	0...200	0	Average motor current (x 1% FLA)	–	√	√
Out_word	INT	–	–	This output is only used when program number is 10, 20, or 30. See next table and program number description.	–	–	–

The following table describes the Out_word output:

Output	Type	Bit	Description	LUCA LUCL	LUCB LUCC LUCD	LUCM
Out_word	INT	0	System ready: the rotary handle is turned to On position and there is no fault.	√	√	√
		1	Pole status: closed	√	√	√
		2	All faults	√	√	√
		3	All warnings	√	√	√
		4	System tripped: the rotary handle is turned to Trip position.	√	√	√
		5	Fault reset authorized	–	√	√
		6	Reserved	–	–	–
		7	Motor running with detection of current, if greater than 10% FLA	–	√	√
		8...13	Average motor current (% FLA) 32 = 100% FLA 63 = 200% FLA	–	√	√
		14	Reserved	–	–	–
15	Start in progress: 0 = descending current is lower than 150% FLA 1 = ascending current is greater than 10% FLA	–	√	√		

Public Variables Characteristics

The following table describes the Ctrl_cmd_mdb_u_addr DFB public variables (using XWAY addressing) and their availability according to the control unit:

Public Variable	Type	Range	Default Value	Description	LUCA LUCL	LUCB LUCC LUCD	LUCM
Net_num	INT	0...255	0	Network address	√	√	√
Stat_num	INT	0...255	0	Station address	√	√	√
Rack_num	INT	0...7	0	Destination rack address	√	√	√
Slot_num	INT	0...10	0	Destination slot address	√	√	√
Chan_num	INT	0...1	0	Destination channel address	√	√	√
Sq_princ	INT	0...7	0	Reserved for support	√	√	√

The following table describes the Ctrl_cmd_mdb_u_addm DFB public variables (using M340 addressing) and their availability according to the control unit:

Public Variable	Type	Range	Default Value	Description	LUCA LUCL	LUCB LUCC LUCD	LUCM
Rack_num	INT	0...7	0	Destination rack address	√	√	√
Slot_num	INT	0...10	0	Destination slot address	√	√	√
Chan_num	INT	0...1	0	Destination channel address	√	√	√
IP_addr1	INT	0...255	0	First byte of IP address	√	√	√
IP_addr2	INT	0...255	0	Second byte of IP address	√	√	√
IP_addr3	INT	0...255	0	Third byte of IP address	√	√	√
IP_addr4	INT	0...255	0	Fourth byte of IP address	√	√	√
Sq_princ	INT	0...7	0	Reserved for support	√	√	√

Comm_manager_u: TeSys U Communication Management for Modbus SL

Presentation

The Comm_manager_u DFB is dedicated to the control and command of up to 31 TeSys U starter-controllers with any control unit and a LULC033 Modbus communication module through the Modbus SL (Serial Line) network. It must be associated with the Ctrl_cmd_mdb_u_*** DFBs to manage the Modbus requests sequencing.

The number of TeSys U Modbus slaves is defined in the Slav_num variable (Slav_num = 1...31).

For more information, see the *TeSys U LULC032-033 Modbus Communication Module User Manual*.

Characteristics

Characteristic	Value
Name	Comm_manager_u
Version	1.00
Input	4
Output	4
Input/Output	0
Public Variable	3

Graphical Representation

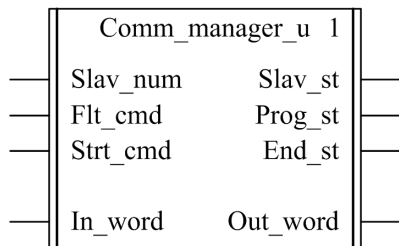

TeSys U Compliance

The Comm_manager_u DFB is compliant with the following TeSys U sub-assemblies:

Power base	<ul style="list-style-type: none"> • LUB** non-reversing power base • LU2B** reversing power base
Control unit	<ul style="list-style-type: none"> • LUCA standard control unit • LUCB and LUCD advanced control units • LUCC advanced control unit (up to 32 A/15 kW or 20 hp) • LUCL magnetic control unit • LUCM multifunction control unit (up to 32 A/15 kW or 20 hp)
Communication module	<ul style="list-style-type: none"> • LULC033 Modbus communication module

Software Implementation

The following figure shows a Unity Pro program extract in FBD language showing how to interconnect the Ctrl_cmd_mdb_u_addr and the Comm_manager_u DFBs:

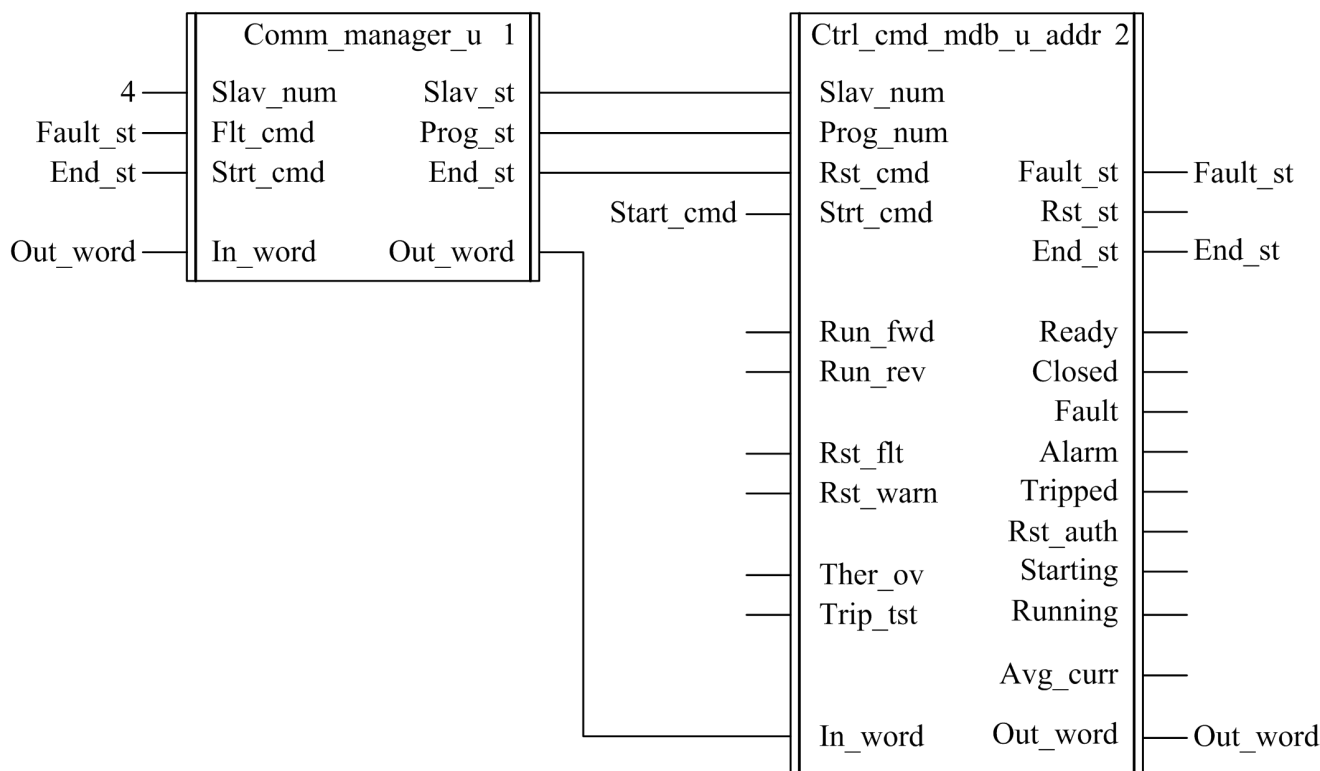

Input Characteristics

The following table describes the DFB inputs:

Input	Type	Range	Default Value	Description
Slav_num	INT	1...31	1	Modbus slave number
Flt_cmd	EBOOL	0...1	0	Reset command
Strt_cmd	EBOOL	0...1	0	Start command
In_word	INT	-	-	To connect to the Out_word output of the Ctrl_cmd_mdb_u_.... DFB

Output Characteristics

The following table describes the DFB outputs:

Output	Type	Range	Default Value	Description
Slav_st	INT	1...31	1	Modbus slave number
Prog_st	INT	20 or 30	-	Program number of the Ctrl_cmd_mdb_u_.... DFB
End_st	EBOOL	0...1	0	End state
Out_word	INT	-	-	To connect to the In_word input of the Ctrl_cmd_mdb_u_.... DFB

Public Variables Characteristics

The following table describes the DFB public variables:

Public Variable	Type	Range	Default Value	Description
In_cmd[0]...[31]	ARRAY [0...31] of INT	–	–	See <i>In_cmd[0]...[31] Public Variable, page 28</i>
Out_urg	INT	–	–	Priority level Bit 0 = Pulling Bit 1 = Writing priority Bit 2 = Reading priority Bit 3 = Fault priority
Out_st[0]...[31]	ARRAY [0...31] of INT	–	–	See <i>Out_st[0]...[31] Public Variable, page 29</i>

In_cmd[0]...[31] Public Variable

The In_cmd[0]...[31] public variable is a table of 32 words corresponding to the TeSys U Modbus slave address. The following table describes the In_cmd[0]...[31] public variable:

Public Variable	Type	Bit	Description Corresponding to the TeSys U Slave 1...31	LUCA LUCL	LUCB LUCC LUCD	LUCM
In_cmd[0]	INT	–	Not significant	–	–	–
In_cmd[1]...[31]	INT	0	Motor run forward command	√	√	√
		1	Motor run reverse command	√	√	√
		2	Reserved	–	–	–
		3	Reset device (if register 451 = 102 or 104, fault acknowledgment causes a return to communication module factory settings)	√	√	√
		4	Reserved	–	–	–
		5	Automatic thermal overload fault test	–	–	√
		6	Overcurrent trip test via communication bus	–	–	√
		7	Reserved	–	–	–
		8	Reset warning (for example, communication loss)	√	√	√
9...15	Reserved	–	–	–		

Out_st[0]...[31] Public Variable

The Out_st[0]...[31] public variable is a table of 32 words corresponding to the TeSys U Modbus slave address. The following table describes the Out_st[0]...[31] public variable:

Public Variable	Type	Bit	Description Corresponding to the TeSys U Slave 1...31	LUCA LUCL	LUCB LUCC LUCD	LUCM
Out_st[0]	INT	–	Not significant	–	–	–
Out_st[1]...[31]	INT	0	System ready: the rotary handle is turned to On position and there is no fault.	√	√	√
		1	Pole status: closed	√	√	√
		2	All faults	√	√	√
		3	All warnings	√	√	√
		4	System tripped: the rotary handle is turned to Trip position.	√	√	√
		5	Fault reset is authorized	–	√	√
		6	Reserved	–	–	–
		7	Motor running with detection of current, if greater than 10% FLA	–	√	√
		8...13	Average motor current (% FLA) 32 = 100% FLA 63 = 200% FLA	–	√	√
		14	Reserved	–	–	–
15	Start in progress: 1 = ascending current is greater than 10% FLA 0 = descending current is lower than 150% FLA	–	√	√		

Ctrl_cmd_mdb_t_****: TeSys T Control/Command for Modbus SL

Presentation

The Ctrl_cmd_mdb_t_**** DFBs are dedicated to the control and command of a single TeSys T LTMR**M** Modbus SL controller with or without the LTM E expansion module through the Modbus SL network.

- Ctrl_cmd_mdb_t_addr uses XWAY addressing and is dedicated to Premium PLCs
- Ctrl_cmd_mdb_t_addm uses an addressing method dedicated to M340 PLCs

For more information, see the *TeSys T LTMR Modbus Communication Guide*.

Characteristics

Characteristic	Value	
Name	Ctrl_cmd_mdb_t_addr	Ctrl_cmd_mdb_t_addm
Version	1.00	1.00
Input	10	10
Output	24	24
Input/Output	0	0
Public Variable	6	8

Graphical Representation

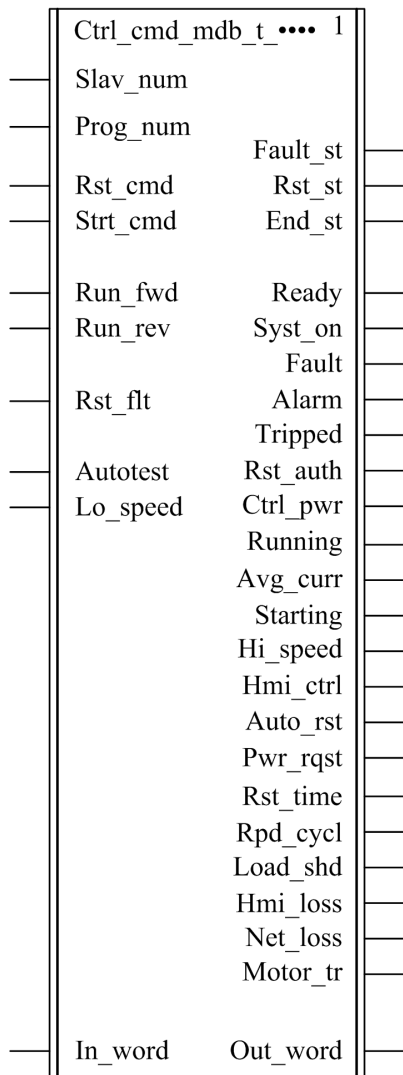

TeSys T Compliance

The Ctrl_cmd_mdb_t_*** DFBs are compliant with all the TeSys T LTM R**M** controller versions, with or without the LTM E expansion module.

Software Implementation

- The parameters and the inputs can only be changed if the End_st output variable is set to 1.
- The output data is only valid if the End_st output variable is set to 1 and if there is no fault detected (Fault_st = 0).

Input Characteristics

The following table describes the DFB inputs:

Input	Type	Range	Default Value	Description
Slav_num	INT	1...31	1	Modbus slave number
Prog_num	INT	1...30	–	See <i>Program Number</i> , page 31
Rst_cmd	EBOOL	0...1	0	Reset command
Strt_cmd	EBOOL	0...1	0	Start command
Run_fwd	EBOOL	0...1	0	Motor run forward command
Run_rev	EBOOL	0...1	0	Motor run reverse command
Rstflt	EBOOL	0...1	0	Fault reset command
Autotest	EBOOL	0...1	0	Self test command
Lo_speed	EBOOL	0...1	0	Motor low speed command
In_word	INT	–	–	This input is only used when program number is 10, 20, or 30. See next table and program number description.

The following table describes the In_word input:

Input	Type	Bit	Description
In_word	INT	0	Motor run forward command
		1	Motor run reverse command
		2	Reserved
		3	Fault reset command
		4	Reserved
		5	Self test command
		6	Motor low speed command
		7...15	Reserved

Program Number

The program number enables the user to select bit or word control.

The following table describes the programs of the DFB:

Program Number	Description
1	Read registers 455 and 456, then write register 704 (systematic)
2	Read registers 455 and 456, then write register 704 (conditional)
3	Write register 704
10	Same as program 1 but using the In_word input and the Out_word output
20	Same as program 2 but using the In_word input and the Out_word output
30	Same as program 3 but using the In_word input and the Out_word output

Output Characteristics

The following table describes the DFB outputs:

Output	Type	Range	Default Value	Description
Fault_st	EBOOL	0...1	0	Fault detected
Rst_st	EBOOL	0...1	0	Reset state
End_st	EBOOL	0...1	0	End state
Ready	EBOOL	0...1	0	System ready
Syst_on	EBOOL	0...1	0	System On
Fault	EBOOL	0...1	0	System fault
Alarm	EBOOL	0...1	0	System warning
Tripped	EBOOL	0...1	0	System tripped
Rst_auth	EBOOL	0...1	0	Fault reset authorized
Ctrl_pwr	EBOOL	0...1	0	Controller power
Running	EBOOL	0...1	0	Motor running (with detection of a current, if greater than 10% FLC)
Avg_curr	INT	0...200	0	Motor average current ratio (x 1% FLC)
Starting	EBOOL	0...1	0	Motor starting (start in progress) 0 = descending current is less than 150% FLC 1 = ascending current is greater than 10% FLC
Hi_speed	EBOOL	0...1	0	Motor high speed
Hmi_ctrl	EBOOL	0...1	0	Control through HMI
Auto_rst	EBOOL	0...1	0	Auto-reset active
Pwr_rqst	EBOOL	0...1	0	Power cycle requested
Rst_Time	EBOOL	0...1	0	Motor restart time undefined
Rpd_cycl	EBOOL	0...1	0	Rapid cycle lockout
Load_shd	EBOOL	0...1	0	Load shedding
Hmi_loss	EBOOL	0...1	0	HMI port communication loss
Net_loss	EBOOL	0...1	0	Network port communication loss
Motor_tr	EBOOL	0...1	0	Motor transition lockout
Out_word	DINT	–	–	This output is only used when program number is 10, 20, or 30. See next table and program number description.

The following table describes the Out_word output:

Output	Type	Bit	Description
Out_word	DINT	0	System ready
		1	System On
		2	System fault
		3	System warning
		4	System tripped
		5	Fault reset authorized
		6	Controller power
		7	Motor running (with detection of a current, if greater than 10% FLC)
		8...13	Motor average current ratio 32 = 100% FLC 63 = 200% FLC
		14	Control through HMI
		15	Motor starting (start in progress) 0 = descending current is less than 150% FLC 1 = ascending current is greater than 10% FLC
		16	Auto-reset active
		17	Not significant
		18	Power cycle requested
		19	Motor restart time undefined
		20	Rapid cycle lockout
		21	Load shedding
		22	Motor speed 0 = FLC1 setting is used 1 = FLC2 setting is used
		23	HMI port communication loss
		24	Network port communication loss
25	Motor transition lockout		
26...31	Not significant		

Public Variables Characteristics

The following table describes the Ctrl_cmd_mdb_t_addr DFB public variables (using XWAY addressing):

Public Variable	Type	Range	Default Value	Description
Net_num	INT	0...255	0	Network address
Stat_num	INT	0...255	0	Station address
Rack_num	INT	0...7	0	Destination rack address
Slot_num	INT	0...10	0	Destination slot address
Chan_num	INT	0...1	0	Destination channel address
Sq_princ	INT	0...7	0	Reserved for support

The following table describes the Ctrl_cmd_mdb_t_addrm DFB public variables (using M340 addressing):

Public Variable	Type	Range	Default Value	Description
Rack_num	INT	0...7	0	Destination rack address
Slot_num	INT	0...10	0	Destination slot address
Chan_num	INT	0...1	0	Destination channel address
IP_addr1	INT	0...255	0	First byte of IP address
IP_addr2	INT	0...255	0	Second byte of IP address
IP_addr3	INT	0...255	0	Third byte of IP address
IP_addr4	INT	0...255	0	Fourth byte of IP address
Sq_princ	INT	0...7	0	Reserved for support

Comm_manager_t: TeSys T Communication Management for Modbus SL

Presentation

The Comm_manager_t DFB is dedicated to the control and command of up to 31 TeSys T LTMR••M•• Modbus SL controllers with or without the LTM E expansion module through the Modbus SL network. It must be associated with the Ctrl_cmd_mdb_t••• DFB to manage the Modbus requests sequencing.

The number of TeSys T Modbus slaves is define din the Slav_num variable (Slav_num = 1...31).

For more information, see the *TeSys T LTMR Modbus Communication Guide*.

Characteristics

Characteristic	Value
Name	Comm_manager_t
Version	1.0
Input	4
Output	4
Input/Output	0
Public Variable	3

Graphical Representation

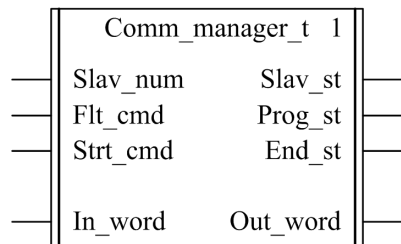

TeSys T Compliance

The Comm_manager_t DFB is compliant with all the TeSys T LTM R••M•• controller versions, with or without the LTM E expansion module.

Software Implementation

The following figure shows a Unity Pro program extract in FBD language showing how to interconnect the Ctrl_cmd_mdb_t and the Comm_manager_t DFBs:

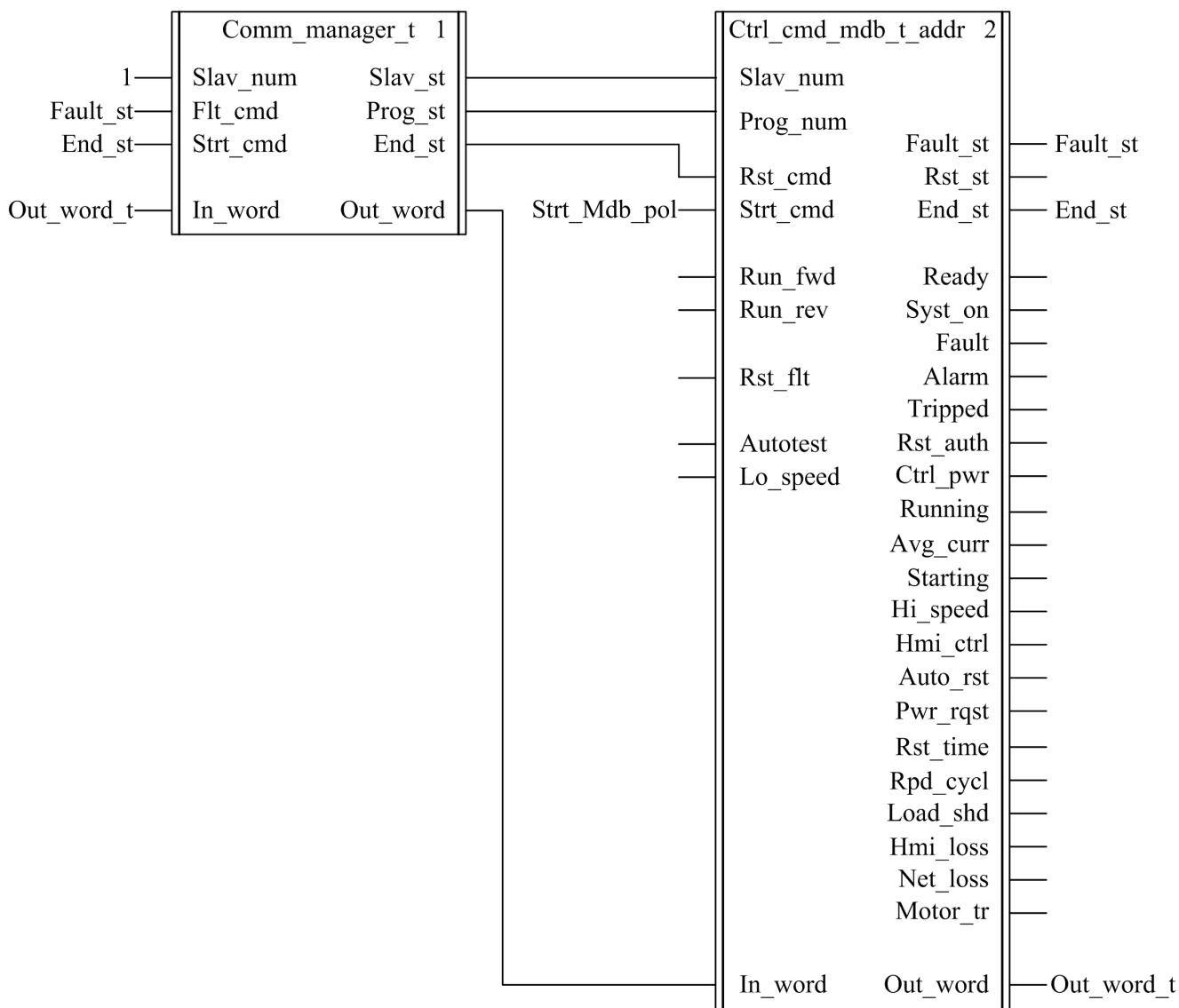

The Comm_manager_t DFB can be used in case both TeSys U starter-controllers and TeSys T motor management systems are present on the same Modbus SL network.

Input Characteristics

The following table describes the DFB inputs:

Input	Type	Range	Default Value	Description
Slav_num	INT	1...31	1	Modbus slave number
Flt_cmd	EBOOL	0...1	0	Reset command
Strt_cmd	EBOOL	0...1	0	Start command
In_word	DINT	-	-	To connect to the Out_word output of the Ctrl_cmd_mdb_t **** DFB

Output Characteristics

The following table describes the DFB outputs:

Output	Type	Range	Default Value	Description
Slav_st	INT	1...31	1	Modbus slave number
Prog_st	INT	20 or 30	–	Program number of the Ctrl_cmd_mdb_t.... DFB
End_st	EBOOL	0...1	0	End state
Out_word	INT	–	–	To connect to the In_word input of the Ctrl_cmd_mdb_t.... DFB

Public Variables Characteristics

The following table describes the DFB public variables:

Public Variable	Type	Range	Default Value	Description
In_cmd[0]...[31]	ARRAY [0...31] of INT	–	–	See <i>In_cmd[0]...[31] Public Variable, page 36</i>
Out_urg	INT	–	–	Priority level Bit 0 = Pulling Bit 1 = Writing priority Bit 2 = Reading priority Bit 3 = Fault priority
Out_st[0]...[31]	ARRAY [0...31] of DINT	–	–	See <i>Out_st[0]...[31] Public Variable, page 37</i>

In_cmd[0]...[31] Public Variable

The In_cmd[0]...[31] public variable is a table of 32 words corresponding to the TeSys T Modbus slave address. The following table describes the In_cmd[0]...[31] public variable:

Public Variable	Type	Bit	Description Corresponding to the TeSys T Slave 1...31
In_cmd[0]	INT	–	Not significant
In_cmd[1]...[31]	INT	0	Motor run forward command
		1	Motor run reverse command
		2	Reserved
		3	Fault reset command
		4	Reserved
		5	Self test command
		6	Motor low speed command
		7...31	Reserved

Out_st[0]...[31] Public Variable

The Out_st[0]...[31] public variable is a table of 32 words corresponding to the TeSys T Modbus slave address. The following table describes the Out_st[0]...[31] public variable:

Public Variable	Type	Bit	Description Corresponding to the TeSys T Slave 1...31
Out_st[0]	DINT	–	Not significant
Out_st[1]...[31]	DINT	0	System ready
		1	System On
		2	System fault
		3	System warning
		4	System tripped
		5	Fault reset authorized
		6	Controller power
		7	Motor running (with detection of a current, if greater than 10% FLC)
		8...13	Motor average current ratio 32 = 100% FLC 63 = 200% FLC
		14	Control through HMI
		15	Motor starting (start in progress) 0 = descending current is less than 150% FLC 1 = ascending current is greater than 10% FLC
		16	Auto-reset active
		17	Not significant
		18	Power cycle requested
		19	Motor restart time undefined
		20	Rapid cycle lockout
		21	Load shedding
		22	Motor speed 0 = FLC1 setting is used 1 = FLC2 setting is used
		23	HMI port communication loss
		24	Network port communication loss
25	Motor transition lockout		
26...31	Not significant		

The Out_st[0]...[31] public variable is a table of 32 words corresponding to the TeSys T Modbus slave address. The following table describes the Out_st[0]...[31] public variable:

Public Variable	Type	Bit	Description Corresponding to the TeSys T Slave 1...31
Out_st[0]	DINT	–	Not significant
Out_st[1]...[31]	DINT	0	System ready
		1	System On
		2	System fault
		3	System warning
		4	System tripped
		5	Fault reset authorized
		6	Controller power
		7	Motor running (with detection of a current, if greater than 10% FLC)
		8...13	Motor average current ratio 32 = 100% FLC 63 = 200% FLC
		14	Control through HMI
		15	Motor starting (start in progress) 0 = descending current is less than 150% FLC 1 = ascending current is greater than 10% FLC
		16	Auto-reset active
		17	Not significant
		18	Power cycle requested
		19	Motor restart time undefined
		20	Rapid cycle lockout
		21	Load shedding
		22	Motor speed 0 = FLC1 setting is used 1 = FLC2 setting is used
		23	HMI port communication loss
		24	Network port communication loss
		25	Motor transition lockout
		26...31	Not significant

Chapter 3

Modbus SL and Modbus/TCP DFB

Introduction

This chapter describes the TeSys U and TeSys T Modbus SL and Modbus/TCP DFBs dedicated to Premium and M340 PLCs.

What Is in This Chapter?

This chapter contains the following topics:

Topic	Page
Special_mdb_u_****: TeSys U DFB for Modbus SL and Modbus/TCP	40
Special_mdb_t_****: TeSys T DFB for Modbus SL and Modbus/TCP	46
Custom_mdb_****: Custom Read DFB for Modbus SL and Modbus/TCP	58

Special_mdb_u_****: TeSys U DFB for Modbus SL and Modbus/TCP

Presentation

The Special_mdb_u_**** DFBs are dedicated to the reading of up to 16 predefined registers of a TeSys U starter-controller (up to 32 A/15 kW or 20 hp) equipped with a LUCM multifunction control unit and a LULC033 Modbus communication module directly through a Modbus SL network or through an Ethernet gateway with a Modbus/TCP network.

- Special_mdb_u_addr uses XWAY addressing and is dedicated to Premium PLCs and can be used with a TeSys U starter-controller connected on Modbus Serial Line or through a Modbus/TCP gateway.
- Special_mdb_u_addm uses an addressing method dedicated to M340 PLCs and can be used with a TeSys U starter-controller connected on Modbus Serial Line or through a Modbus/TCP gateway.

For more information, see the *TeSys U LULC032-033 Modbus Communication Module User Manual*.

Characteristics

Characteristic	Value	
Name	Special_mdb_u_addr	Special_mdb_u_addm
Version	1.00 and 1.10	1.00 and 1.10
Input	4	4
Output	3	3
Input/Output	0	0
Public Variable	7	9

Graphical Representation

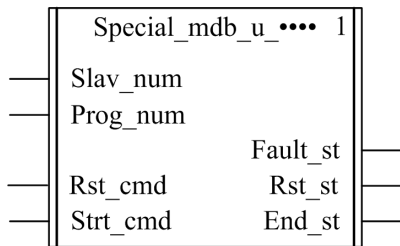

TeSys U Compliance

The Special_mdb_u_**** DFBs are compliant with the following TeSys U sub-assemblies:

Power base	<ul style="list-style-type: none"> • LUB** non-reversing power base (up to 32 A/15 kW or 20 hp) • LU2B** reversing power base (up to 32 A/15 kW or 20 hp)
Control unit	<ul style="list-style-type: none"> • LUCM multifunction control unit
Communication module	<ul style="list-style-type: none"> • LULC033 Modbus communication module

Software Implementation

- The parameters and the inputs can only be changed if the End_st output variable is set to 1.
- With version 1.00:
The output data is only valid if the End_st output variable is set to 1 and if there is no fault detected (Fault_st = 0).
- With version 1.10:
The output data is only valid if there is no fault detected (Fault_st = 0).
Prog_num input can be modified on the fly.

Input Characteristics

The following table describes the DFB inputs:

Input	Type	Range	Default Value	Description
Slav_num	INT	1...31	1	Modbus slave number
Prog_num	INT	0...6	0	Program number See <i>Program Number</i> , page 41
Rst_cmd	EBOOL	0...1	0	Reset command
Strt_cmd	EBOOL	0...1	0	Start command

Output Characteristics

The following table describes the DFB outputs:

Output	Type	Range	Default Value	Description
Fault_st	EBOOL	0...1	0	Fault detected
Rst_st	EBOOL	0...1	0	Reset state
End_st	EBOOL	0...1	0	End state

Program Number

The Prog_num input variable enables the user to define the public variables data depending on the application type. Each program uses variables related to one application (diagnostic, maintenance, measurement,...). The following table describes the programs of the DFB:

Program Number	Description
0	Bypass: no action
1	Diagnostic: faults monitoring variables, warnings monitoring variables, and communication monitoring variables
2	Maintenance: global statistics variables
3	Measurements: measurements monitoring variables
4	Statistics: last trip statistics and trip N-1 statistics
5	Statistics: trip N-2 statistics and trip N-3 statistics
6	Statistics: trip N-4 statistics

Public Variables Characteristics

The following table describes the Special_mdb_u_addr DFBs public variables (using XWAY addressing):

Public Variable	Type	Range	Default Value	Description
Net_num	INT	0...255	0	Network address
Stat_num	INT	0...255	0	Station address
Rack_num	INT	0...7	0	Destination rack address
Slot_num	INT	0...10	0	Destination slot address
Chan_num	INT	0...1	0	Destination channel address
Sq_princ	INT	0...7	0	Reserved for support
Out_data[0]...[15]	ARRAY [0...15] of INT	0...65535	0	The output data depends on the program number. See <i>Out_data[0]...[15] Public Variable (Program 1)</i> , page 42 ... <i>Out_data[0]...[15] Public Variable (Program 6)</i> , page 45

The following table describes the Special_mdb_u_addm DFB public variables (using M340 addressing):

Public Variable	Type	Range	Default Value	Description
Rack_num	INT	0...7	0	Destination rack address
Slot_num	INT	0...10	0	Destination slot address
Chan_num	INT	0...1	0	Destination channel address
IP_addr1	INT	0...255	0	First byte of IP address
IP_addr2	INT	0...255	0	Second byte of IP address
IP_addr3	INT	0...255	0	Third byte of IP address

Public Variable	Type	Range	Default Value	Description
IP_addr4	INT	0...255	0	Fourth byte of IP address
Sq_princ	INT	0...7	0	Reserved for support
Out_data[0]...[15]	ARRAY [0...15] of INT	0...65535	0	The output data depends on the program number. See <i>Out_data[0]...[15] Public Variable (Program 1)</i> , page 42... <i>Out_data[0]...[15] Public Variable (Program 6)</i> , page 45

Out_data[0]...[15] Public Variable (Program 1)

The following table describes the Out_data[0]...[15] public variable in the case of the diagnostic program (program number 1):

Public Variable	Type	Register	Bit	Description
Out_data[0]	INT	452	0	Short-circuit fault
			1	Magnetic fault
			2	Ground fault
			3	Thermal fault
			4	Long start fault
			5	Jam fault
			6	Phase imbalance fault
			7	Underload fault
			8	Shunt trip fault
			9	Test trip fault
			10	Communication loss fault on LUCM Modbus port
			11	Control unit internal fault
			12	Module identification or internal communication fault
			13	Module internal fault
			14	Module trip fault
15	Module drop-out fault			
Out_data[1]	INT	461	0...1	Not significant
			2	Ground fault warning
			3	Thermal warning
			4	Long start warning
			5	Jam warning
			6	Phase imbalance warning
			7	Under-current warning
			8...9	Not significant
			10	Communication loss fault on LUCM Modbus port
			11	Internal temperature warning
			12	Module identification or internal communication warning
			13...14	Not significant
15	Module warning			
Out_data[2]	INT	457	0	Button position On (0 = Off)
			1	Button position Trip (0 = Not tripped)
			2	Contactors state On
			3	24 Vdc power supply present on outputs
			4...15	Not significant
Out_data[3]	INT	450	-	Time to automatic reset on a thermal fault (s)
Out_data[4] ...Out_data[15]	-	-	-	Not significant

Out_data[0]...[15] Public Variable (Program 2)

The following table describes the Out_data[0]...[15] public variable in the case of the maintenance program (program number 2):

Public Variable	Type	Register	Description
Out_data[0]	INT	100	Short-circuit faults count
Out_data[1]	INT	101	Magnetic faults count
Out_data[2]	INT	102	Ground faults count
Out_data[3]	INT	103	Thermal faults count
Out_data[4]	INT	104	Long start faults count
Out_data[5]	INT	105	Jam faults count
Out_data[6]	INT	106	Phase imbalance faults count
Out_data[7]	INT	108	Shunt trip faults count
Out_data[8]	INT	115	Auto-resets count
Out_data[9]	INT	116	Thermal warnings count
Out_data[10]	INT	117	Starts count (LSB)
Out_data[11]	INT	118	Starts count (MSB)
Out_data[12]	INT	119	Operating time (LSB)
Out_data[13]	INT	120	Operating time (MSB)
Out_data[14]	INT	121	Maximum internal temperature (°C)
Out_data[15]	–	–	Not significant

Out_data[0]...[15] Public Variable (Program 3)

The following table describes the Out_data[0]...[15] public variable in the case of the measurements program (program number 3):

Public Variable	Type	Register	Description
Out_data[0]	–	–	Not significant
Out_data[1]	INT	465	Thermal capacity level (%)
Out_data[2]	INT	466	Average motor current (x 0.1 % FLA)
Out_data[3]	INT	467	L1 current (% FLA)
Out_data[4]	INT	468	L2 current (% FLA)
Out_data[5]	INT	469	L3 current (% FLA)
Out_data[6]	INT	470	Ground current (% FLA min)
Out_data[7]	INT	471	Current imbalance coefficient
Out_data[8]	INT	472	Control unit internal temperature (°C)
Out_data[9] ...Out_data[13]	–	–	Not significant
Out_data[14]	INT	79	Control unit sensor maximum current (x 0.1 A): <ul style="list-style-type: none"> ● 6 = adjustment range 0.15–0.6 A ● 14 = adjustment range 0.35–.4 A ● 50 = adjustment range 1.25–5 A ● 120 = adjustment range 3–12 A ● 180 = adjustment range 4.5–18 A ● 320 = adjustment range 8–32 A
Out_data[15]	INT	652	Full load amps setting (% FLA max): <ul style="list-style-type: none"> ● minimum = 25 (default value) ● maximum = 100

Out_data[0]...[15] Public Variable (Program 4)

The following table describes the Out_data[0]...[15] public variable in the case of the statistics program (program number 4):

Public Variable	Type	Register	Description
Out_data[0]	INT	150	Last trip fault number
Out_data[1]	INT	152	Last trip thermal capacity level (% trip level)
Out_data[2]	INT	153	Last trip average current (% FLA)
Out_data[3]	INT	154	Last trip L1 current (% FLA)
Out_data[4]	INT	155	Last trip L2 current (% FLA)
Out_data[5]	INT	156	Last trip L3 current (% FLA)
Out_data[6]	INT	157	Last trip ground current (% FLA min)
Out_data[7]	INT	180	N1 trip fault number
Out_data[8]	INT	182	N-1 trip thermal capacity level (% trip level)
Out_data[9]	INT	183	N-1 trip average current (% FLA)
Out_data[10]	INT	184	N-1 trip L1 current (% FLA)
Out_data[11]	INT	185	N-1 trip L2 current (%FLA)
Out_data[12]	INT	186	N-1 trip L3 current (% FLA)
Out_data[13]	INT	187	N-1 trip ground current (% FLA min)
Out_data[14]	INT	79	Control unit sensor maximum current (x 0.1 A): <ul style="list-style-type: none"> ● 6 = adjustment range 0.15–0.6 A ● 14 = adjustment range 0.35–1.4 A ● 50 = adjustment range 1.25–5 A ● 120 = adjustment range 3–12 A ● 180 = adjustment range 4.5–18 A ● 320 = adjustment range 8–32 A
Out_data[15]	INT	652	Full load amps setting (% FLA max): <ul style="list-style-type: none"> ● minimum = 25 (default value) ● maximum = 100

Out_data[0]...[15] Public Variable (Program 5)

The following table describes the Out_data[0]...[15] public variable in the case of the statistics program (program number 5):

Public Variable	Type	Register	Description
Out_data[0]	INT	210	N-2 trip fault number
Out_data[1]	INT	212	N-2 trip thermal capacity level (% trip level)
Out_data[2]	INT	213	N-2 trip average current (% FLA)
Out_data[3]	INT	214	N-2 trip L1 current (% FLA)
Out_data[4]	INT	215	N-2 trip L2 current (% FLA)
Out_data[5]	INT	216	N-2 trip L3 current (% FLA)
Out_data[6]	INT	217	N-2 trip ground current (% FLA min)
Out_data[7]	INT	240	N-3 trip fault number
Out_data[8]	INT	242	N-3 trip thermal capacity level (% trip level)
Out_data[9]	INT	243	N-3 trip average current (% FLA)
Out_data[10]	INT	244	N-3 trip L1 current (% FLA)
Out_data[11]	INT	245	N-3 trip L2 current (%FLA)
Out_data[12]	INT	246	N-3 trip L3 current (% FLA)
Out_data[13]	INT	247	N-3 trip ground current (% FLA min)
Out_data[14]	INT	79	Control unit sensor maximum current (x 0.1 A): <ul style="list-style-type: none"> ● 6 = adjustment range 0.15–0.6 A ● 14 = adjustment range 0.35–1.4 A ● 50 = adjustment range 1.25–5 A ● 120 = adjustment range 3–12 A ● 180 = adjustment range 4.5–18 A ● 320 = adjustment range 8–32 A
Out_data[15]	INT	652	Full load amps setting (% FLA max): <ul style="list-style-type: none"> ● minimum = 25 (default value) ● maximum = 100

Out_data[0]...[15] Public Variable (Program 6)

The following table describes the Out_data[0]...[15] public variable in the case of the statistics program (program number 6):

Public Variable	Type	Register	Description
Out_data[0]	INT	270	N-4 trip fault number
Out_data[1]	INT	272	N-4 trip thermal capacity level (% trip level)
Out_data[2]	INT	273	N-4 trip average current (% FLA)
Out_data[3]	INT	274	N-4 trip L1 current (% FLA)
Out_data[4]	INT	275	N-4 trip L2 current (% FLA)
Out_data[5]	INT	276	N-4 trip L3 current (% FLA)
Out_data[6]	INT	277	N-4 trip ground current (% FLA min)
Out_data[7] ...Out_data[13]	–	–	Reserved
Out_data[14]	INT	79	Control unit sensor maximum current (x 0.1 A): <ul style="list-style-type: none"> ● 6 = adjustment range 0.15–0.6 A ● 14 = adjustment range 0.35–1.4 A ● 50 = adjustment range 1.25–5 A ● 120 = adjustment range 3–12 A ● 180 = adjustment range 4.5–18 A ● 320 = adjustment range 8–32 A
Out_data[15]	INT	652	Full load amps setting (% FLA max): <ul style="list-style-type: none"> ● minimum = 25 (default value) ● maximum = 100

Special_mdb_t_***: TeSys T DFB for Modbus SL and Modbus/TCP

Presentation

The Special_mdb_t_*** DFBs are dedicated to the reading of up to 16 predefined registers of a TeSys T LTM R**M** controller through the Modbus SL network or a TeSys T LTM R**E** controller through the Modbus/TCP network.

- Special_mdb_t_addr uses XWAY addressing and is dedicated to Premium PLCs.
- Special_mdb_t_addm uses an addressing method dedicated to M340 PLCs.

For more information, see:

- *TeSys T LTM R Modbus Communication Guide*
- *TeSys T LTM R Ethernet Communication Guide*

Characteristics

Characteristic	Value	
Name	Special_mdb_t_addr	Special_mdb_t_addm
Version	1.00 and 1.10	1.00 and 1.10
Input	4	4
Output	3	3
Input/Output	0	0
Public Variable	7	9

Graphical Representation

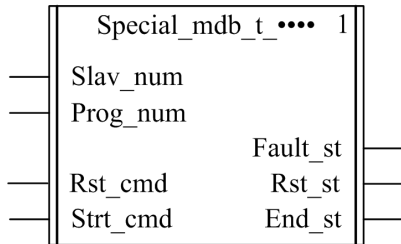

TeSys T Compliance

The Special_mdb_t_*** DFBs are compliant with all the TeSys T LTM R**M** and LTM R**E** controller versions, with or without the LTM E expansion module.

Software Implementation

- The parameters and the inputs can only be changed if the End_st output variable is set to 1.
- With version 1.00:
The output data is only valid if the End_st output variable is set to 1 and if there is no fault detected (Fault_st = 0).
- With version 1.10:
The output data is only valid if there is no fault detected (Fault_st = 0).
Prog_num input can be modified on the fly.

Input Characteristics

The following table describes the DFB inputs:

Input	Type	Range	Default Value	Description
Slav_num	INT	1...31	1	Modbus slave number
Prog_num	INT	0...6	0	Program number See <i>Program Number</i> , page 47
Rst_cmd	EBOOL	0...1	0	Reset command
Strt_cmd	EBOOL	0...1	0	Start command

Output Characteristics

The following table describes the DFB outputs:

Output	Type	Range	Default Value	Description
Fault_st	EBOOL	0...1	0	Fault detected
Rst_st	EBOOL	0...1	0	Reset state
End_st	EBOOL	0...1	0	End state

Program Number

The Prog_num input variable enables the user to define the public variables data depending on the application type. Each program holds variables related to one application (diagnostic, maintenance, measurement,...). The following table describes the programs of the DFB:

Program Number	Description
0	Bypass: no action
10	Diagnostic: faults monitoring variables, warnings monitoring variables, and communication monitoring variables
20	Maintenance: global statistics variables
30	Measurements 1
31	Measurements 2
32	Measurements 3
40	Statistics: last fault statistics (N-0)
41	Statistics: last fault statistics with expansion module (N-0)
50	Statistics: N-1 fault statistics
51	Statistics: N-1 fault statistics (with expansion module)
60	Statistics: N-2 fault statistics
61	Statistics: N-2 fault statistics (with expansion module)
70	Statistics: N-3 fault statistics
71	Statistics: N-3 fault statistics (with expansion module)
80	Statistics: N-4 fault statistics
81	Statistics: N-4 fault statistics (with expansion module)

Public Variables Characteristics

The following table describes the Special_mdb_t_addr DFB public variables (using XWAY addressing):

Public Variable	Type	Range	Default Value	Description
Net_num	INT	0...255	0	Network address
Stat_num	INT	0...255	0	Station address
Rack_num	INT	0...7	0	Destination rack address
Slot_num	INT	0...10	0	Destination slot address
Chan_num	INT	0...1	0	Destination channel address
Sq_princ	INT	0...7	0	Reserved for support
Out_data[0]...[15]	ARRAY [0...15] of INT	0...65535	0	The output data depends on the program number. See <i>Out_data[0]...[15] Public Variable (Program 1)</i> , page 42... <i>Out_data[0]...[15] Public Variable (Program 6)</i> , page 45

The following table describes the Special_mdb_t_addm DFB public variables (using M340 addressing):

Public Variable	Type	Range	Default Value	Description
Rack_num	INT	0...7	0	Destination rack address
Slot_num	INT	0...10	0	Destination slot address
Chan_num	INT	0...1	0	Destination channel address
IP_addr1	INT	0...255	0	First byte of IP address
IP_addr2	INT	0...255	0	Second byte of IP address
IP_addr3	INT	0...255	0	Third byte of IP address

Public Variable	Type	Range	Default Value	Description
IP_addr4	INT	0...255	0	Fourth byte of IP address
Sq_princ	INT	0...7	0	Reserved for support
Out_data[0]...[15]	ARRAY [0...15] of INT	0...65535	0	The output data depends on the program number. See <i>Out_data[0]...[15] Public Variable (Program 1)</i> , page 42... <i>Out_data[0]...[15] Public Variable (Program 6)</i> , page 45

Out_data[0]...[15] Public Variable (Program 10)

The following table describes the Out_data[0]...[15] public variable in the case of the diagnostic program (program number 10):

Public Variable	Type	Register	Bit	Description
Out_data[0]	INT	452	0...1	Reserved
			2	Ground current fault
			3	Thermal overload fault
			4	Long start fault
			5	Jam fault
			6	Current phase imbalance fault
			7	Undercurrent fault
			8	Reserved
			9	Test fault
			10	HMI port fault
			11	Controller internal fault
			12	Internal port fault
			13	Not significant
			14	Network port config fault
			15	Network port fault
Out_data[1]	INT	453	0	External system fault
			1	Diagnostic fault
			2	Wiring fault
			3	Overcurrent fault
			4	Current phase loss fault
			5	Current phase reversal fault
			6	Motor temperature sensor fault (1)
			7	Voltage phase imbalance fault (1)
			8	Voltage phase loss fault (1)
			9	Voltage phase reversal fault (1)
			10	Undervoltage fault (1)
			11	Overvoltage fault (1)
			12	Underpower fault (1)
			13	Overpower fault (1)
			14	Under power factor fault (1)
15	Over power factor fault (1)			

Public Variable	Type	Register	Bit	Description
Out_data[2]	INT	461	0...1	Not significant
			2	Ground current warning
			3	Thermal overload warning
			4	Not significant
			5	Jam warning
			6	Current phase imbalance warning
			7	Undercurrent warning
			8...9	Not significant
			10	HMI port warning
			11	Controller internal temperature warning
			12...14	Not significant
			15	Network port warning
Out_data[3]	INT	462	0	Not significant
			1	Diagnostic warning
			2	Reserved
			3	Overcurrent warning
			4	Current phase loss warning
			5	Current phase reversal warning
			6	Motor temperature sensor warning
			7	Voltage phase imbalance warning (1)
			8	Voltage phase loss warning (1)
			9	Not significant
			10	Undervoltage warning (1)
			11	Overvoltage warning (1)
			12	Underpower warning (1)
			13	Overpower warning (1)
			14	Under power factor warning (1)
			15	Over power factor warning (1)
Out_data[4]	INT	457	0	Logic input 1
			1	Logic input 2
			2	Logic input 3
			3	Logic input 4
			4	Logic input 5
			5	Logic input 6
			6	Logic input 7
			7	Logic input 8 (1)
			8	Logic input 9 (1)
			9	Logic input 10 (1)
			10	Logic input 11 (1)
			11	Logic input 12 (1)
			12	Logic input 13 (1)
			13	Logic input 14 (1)
			14	Logic input 15 (1)
			15	Logic input 16 (1)

Public Variable	Type	Register	Bit	Description
Out_data[5]	INT	458	0	Logic output 1
			1	Logic output 2
			2	Logic output 3
			3	Logic output 4
			4	Logic output 5 (1)
			5	Logic output 6 (1)
			6	Logic output 7 (1)
			7	Logic output 8 (1)
			8...15	Reserved
Out_data[6]	INT	450	–	Minimum wait time (s)
Out_data[7] ...Out_data[15]	–	–	–	Reserved

(1) The variable is available for the LTM R controller and the LTM EV40 expansion module combination.

Out_data[0]...[15] Public Variable (Program 20)

The following table describes the Out_data[0]...[15] public variable in the case of the maintenance program (program number 20):

Public Variable	Type	Register	Description
Out_data[0]	INT	102	Ground current faults count
Out_data[1]	INT	103	Thermal overload faults count
Out_data[2]	INT	104	Long start faults count
Out_data[3]	INT	105	Jam faults count
Out_data[4]	INT	106	Current phase imbalance faults count
Out_data[5]	INT	107	Undercurrent faults count
Out_data[6]	–	–	Reserved
Out_data[7]	INT	114	Network port faults count
Out_data[8]	INT	115	Auto-resets count
Out_data[9]	INT	116	Thermal overload warnings count
Out_data[10]	INT	117	Motor starts count (LSB)
Out_data[11]	INT	118	Motor starts count (MSB)
Out_data[12]	INT	119	Operating time (s) (LSB)
Out_data[13]	INT	120	Operating time (MSB)
Out_data[14]	INT	121	Maximum controller internal temperature (°C)
Out_data[15]	–	–	Reserved

Out_data[0]...[15] Public Variable (Program 30)

The following table describes the Out_data[0]...[15] public variable in the case of the first measurements program (program number 30):

Public Variable	Type	Register	Description
Out_data[0]	–	–	Reserved
Out_data[1]	INT	465	Thermal capacity level (% trip level)
Out_data[2]	INT	466	Average current ratio (% FLC)
Out_data[3]	INT	467	L1 current ratio (% FLC)
Out_data[4]	INT	468	L2 current ratio (% FLC)
Out_data[5]	INT	469	L3 current ratio (% FLC)
Out_data[6]	INT	470	Ground current ratio (x 0.1 % FLC min)
Out_data[7]	INT	471	Current phase imbalance (%)
Out_data[8]	INT	472	Controller internal temperature (°C)
Out_data[9]	INT	474	Frequency (x 0.01 Hz)
Out_data[10]	INT	475	Motor temperature sensor (x 0.1 Ω)
Out_data[11] ...Out_data[13]	–	–	Reserved
Out_data[14]	INT	96	Full load current (FLC) max (x 0.1 A)
Out_data[15]	INT	652	Motor full load current ratio

Out_data[0]...[15] Public Variable (Program 31)

The following table describes the Out_data[0]...[15] public variable in the case of the second measurements program (program number 31):

Public Variable	Type	Register	Description
Out_data[0]	INT	500	Average current (x 0.01 A) MSB
Out_data[1]	INT	501	Average current (x 0.01 A) LSB
Out_data[2]	INT	502	L1 current (x 0.01 A) MSB
Out_data[3]	INT	503	L1 current (x0.01 A) LSB
Out_data[4]	INT	504	L2 current (x 0.01 A) MSB
Out_data[5]	INT	505	L2 current (x0.01 A) LSB
Out_data[6]	INT	506	L3 current (x 0.01 A) MSB
Out_data[7]	INT	507	L3 current (x0.01 A) LSB
Out_data[8]	INT	508	Ground current (x 0.001 A) MSB
Out_data[9]	INT	509	Ground current (x 0.001 A) LSB
Out_data[10]	INT	511	Time to trip (x 1 s)
Out_data[11]	INT	512	Motor last start current ratio (% FLC)
Out_data[12]	INT	513	Motor last start duration (s)
Out_data[13]	INT	514	Motor starts per hour count
Out_data[14] ...Out_data[15]	–	–	–

Out_data[0]...[15] Public Variable (Program 32)

The following table describes the Out_data[0]...[15] public variable in the case of the third measurements program (program number 32):

Public Variable	Type	Register	Description
Out_data[0]	WORD	476	Average voltage (V)
Out_data[1]	WORD	477	L3–L1 voltage (V)
Out_data[2]	WORD	478	L1–L2 voltage (V)
Out_data[3]	WORD	479	L2–L3 voltage (V)
Out_data[4]	WORD	480	Voltage phase imbalance (%)
Out_data[5]	WORD	481	Power factor (x 0.01)
Out_data[6]	WORD	482	Active power (x 0.1 kW)

Public Variable	Type	Register	Description
Out_data[7]	WORD	483	Reactive power (x 0.1 kVAr)
Out_data[8] ...Out_data[15]	–	–	Reserved

Out_data[0]...[15] Public Variable (Program 40)

The following table describes the Out_data[0]...[15] public variable in the case of the last fault statistics program (program number 40):

Public Variable	Type	Register	Description
Out_data[0]	INT	150	Detected fault code N–0
Out_data[1]	INT	151	Motor full load current ratio N–0 (% FLC max)
Out_data[2]	INT	152	Thermal capacity level N–0 (% trip level)
Out_data[3]	INT	153	Average current ratio N–0 (% FLC)
Out_data[4]	INT	154	L1 current ratio N–0 (% FLC)
Out_data[5]	INT	155	L2 current ratio N–0 (% FLC)
Out_data[6]	INT	156	L3 current ratio N–0 (% FLC)
Out_data[7]	INT	157	Ground current ratio N–0 (x 0.1 % FLC min)
Out_data[8]	INT	158	Full load current max N–0 (x 0.1 A)
Out_data[9]	INT	159	Current phase imbalance N–0 (%)
Out_data[10]	INT	160	Frequency N–0 (x 0.1 Hz)
Out_data[11]	INT	161	Motor temperature sensor N–0 (x 0.1 Ω)
Out_data[12]	WORD[4]	162	Date and time N–0
Out_data[13]		163	See <i>DT_DateTime</i> , page 111
Out_data[14]		164	
Out_data[15]		165	

Out_data[0]...[15] Public Variable (Program 41)

The following table describes the Out_data[0]...[15] public variable in the case of the last fault statistics with expansion module program (program number 41):

Public Variable	Type	Register	Description
Out_data[0]	INT	166	Average voltage N–0 (V)
Out_data[1]	INT	167	L3–L1 voltage N–0 (V)
Out_data[2]	INT	168	L1–L2 voltage N–0 (V)
Out_data[3]	INT	169	L2–L3 voltage N–0 (V)
Out_data[4]	INT	170	Voltage phase imbalance N–0 (%)
Out_data[5]	INT	171	Active power N–0 (kW)
Out_data[6]	INT	172	Power factor N–0 (x 0.01)
Out_data[7] ...Out_data[15]	–	–	Reserved

Out_data[0]...[15] Public Variable (Program 50)

The following table describes the Out_data[0]...[15] public variable in the case of the N-1 fault statistics program (program number 50):

Public Variable	Type	Register	Description
Out_data[0]	INT	180	Detected fault code N-1
Out_data[1]	INT	181	Motor full load current ratio N-1 (% FLC max)
Out_data[2]	INT	182	Thermal capacity level N-1 (% trip level)
Out_data[3]	INT	183	Average current ratio N-1 (% FLC)
Out_data[4]	INT	184	L1 current ratio N-1 (% FLC)
Out_data[5]	INT	185	L2 current ratio N-1 (% FLC)
Out_data[6]	INT	186	L3 current ratio N-1 (% FLC)
Out_data[7]	INT	187	Ground current ratio N-1 (x 0.1 % FLC min)
Out_data[8]	INT	188	Full load current max N-1 (x 0.1 A)
Out_data[9]	INT	189	Current phase imbalance N-1 (%)
Out_data[10]	INT	190	Frequency N-1 (x 0.1 Hz)
Out_data[11]	INT	191	Motor temperature sensor N-1 (x 0.1 Ω)
Out_data[12]	WORD[4]	192	Date and time N-1
Out_data[13]		193	See <i>DT_DateTime</i> , page 111
Out_data[14]		194	
Out_data[15]		195	

Out_data[0]...[15] Public Variable (Program 51)

The following table describes the Out_data[0]...[15] public variable in the case of the N-1 fault statistics with expansion module program (program number 51):

Public Variable	Type	Register	Description
Out_data[0]	INT	196	Average voltage N-1 (V)
Out_data[1]	INT	197	L3-L1 voltage N-1 (V)
Out_data[2]	INT	198	L1-L2 voltage N-1 (V)
Out_data[3]	INT	199	L2-L3 voltage N-1 (V)
Out_data[4]	INT	200	Voltage phase imbalance N-1 (%)
Out_data[5]	INT	201	Active power N-1 (kW)
Out_data[6]	INT	202	Power factor N-1 (x 0.01)
Out_data[7] ...Out_data[15]	-	-	Reserved

Out_data[0]...[15] Public Variable (Program 60)

The following table describes the Out_data[0]...[15] public variable in the case of the N-2 fault statistics program (program number 60):

Public Variable	Type	Register	Description
Out_data[0]	INT	210	Detected fault code N-2
Out_data[1]	INT	211	Motor full load current ratio N-2 (% FLC max)
Out_data[2]	INT	212	Thermal capacity level N-2 (% trip level)
Out_data[3]	INT	213	Average current ratio N-2 (% FLC)
Out_data[4]	INT	214	L1 current ratio N-2 (% FLC)
Out_data[5]	INT	215	L2 current ratio N-2 (% FLC)
Out_data[6]	INT	216	L3 current ratio N-2 (% FLC)
Out_data[7]	INT	217	Ground current ratio N-2 (x 0.1 % FLC min)
Out_data[8]	INT	218	Full load current max N-2 (x 0.1 A)
Out_data[9]	INT	219	Current phase imbalance N-2 (%)
Out_data[10]	INT	220	Frequency N-2 (x 0.1 Hz)
Out_data[11]	INT	221	Motor temperature sensor N-2 (x 0.1 Ω)
Out_data[12]	WORD[4]	222	Date and time N-2
Out_data[13]		223	See <i>DT_DateTime</i> , page 111
Out_data[14]		224	
Out_data[15]		225	

Out_data[0]...[15] Public Variable (Program 61)

The following table describes the Out_data[0]...[15] public variable in the case of the N-2 fault statistics with expansion module program (program number 61):

Public Variable	Type	Register	Description
Out_data[0]	INT	226	Average voltage N-2 (V)
Out_data[1]	INT	227	L3-L1 voltage N-2 (V)
Out_data[2]	INT	228	L1-L2 voltage N-2 (V)
Out_data[3]	INT	229	L2-L3 voltage N-2 (V)
Out_data[4]	INT	230	Voltage phase imbalance N-2 (%)
Out_data[5]	INT	231	Active power N-2 (kW)
Out_data[6]	INT	232	Power factor N-2 (x 0.01)
Out_data[7] ...Out_data[15]	-	-	Reserved

Out_data[0]...[15] Public Variable (Program 70)

The following table describes the Out_data[0]...[15] public variable in the case of the N–3 fault statistics program (program number 70):

Public Variable	Type	Register	Description
Out_data[0]	INT	240	Detected fault code N–3
Out_data[1]	INT	241	Motor full load current ratio N–3 (% FLC max)
Out_data[2]	INT	242	Thermal capacity level N–3 (% trip level)
Out_data[3]	INT	243	Average current ratio N–3 (% FLC)
Out_data[4]	INT	244	L1 current ratio N–3 (% FLC)
Out_data[5]	INT	245	L2 current ratio N–3 (% FLC)
Out_data[6]	INT	246	L3 current ratio N–3 (% FLC)
Out_data[7]	INT	247	Ground current ratio N–3 (x 0.1 % FLC min)
Out_data[8]	INT	248	Full load current max N–3 (x 0.1 A)
Out_data[9]	INT	249	Current phase imbalance N–3 (%)
Out_data[10]	INT	250	Frequency N–3 (x 0.1 Hz)
Out_data[11]	INT	251	Motor temperature sensor N–3 (x 0.1 Ω)
Out_data[12]	WORD[4]	252	Date and time N–3
Out_data[13]		253	See <i>DT_DateTime</i> , page 111
Out_data[14]		254	
Out_data[15]		255	

Out_data[0]...[15] Public Variable (Program 71)

The following table describes the Out_data[0]...[15] public variable in the case of the N–3 fault statistics with expansion module program (program number 71):

Public Variable	Type	Register	Description
Out_data[0]	INT	256	Average voltage N–3 (V)
Out_data[1]	INT	257	L3–L1 voltage N–3 (V)
Out_data[2]	INT	258	L1–L2 voltage N–3 (V)
Out_data[3]	INT	259	L2–L3 voltage N–3 (V)
Out_data[4]	INT	260	Voltage phase imbalance N–3 (%)
Out_data[5]	INT	261	Active power N–3 (kW)
Out_data[6]	INT	262	Power factor N–3 (x 0.01)
Out_data[7] ...Out_data[15]	–	–	Reserved

Out_data[0]...[15] Public Variable (Program 80)

The following table describes the Out_data[0]...[15] public variable in the case of the N-4 fault statistics program (program number 80):

Public Variable	Type	Register	Description
Out_data[0]	INT	270	Detected fault code N-4
Out_data[1]	INT	271	Motor full load current ratio N-4 (% FLC max)
Out_data[2]	INT	272	Thermal capacity level N-4 (% trip level)
Out_data[3]	INT	273	Average current ratio N-4 (% FLC)
Out_data[4]	INT	274	L1 current ratio N-4 (% FLC)
Out_data[5]	INT	275	L2 current ratio N-4 (% FLC)
Out_data[6]	INT	276	L3 current ratio N-4 (% FLC)
Out_data[7]	INT	277	Ground current ratio N-4 (x 0.1 % FLC min)
Out_data[8]	INT	278	Full load current max N-4 (x 0.1 A)
Out_data[9]	INT	279	Current phase imbalance N-4 (%)
Out_data[10]	INT	280	Frequency N-4 (x 0.1 Hz)
Out_data[11]	INT	281	Motor temperature sensor N-4 (x 0.1 Ω)
Out_data[12]	WORD[4]	282	Date and time N-4
Out_data[13]		283	See <i>DT_DateTime</i> , page 111
Out_data[14]		284	
Out_data[15]		285	

Out_data[0]...[15] Public Variable (Program 81)

The following table describes the Out_data[0]...[15] public variable in the case of the N–4 fault statistics with expansion module program (program number 81):

Public Variable	Type	Register	Description
Out_data[0]	INT	286	Average voltage N–4 (V)
Out_data[1]	INT	287	L3–L1 voltage N–4 (V)
Out_data[2]	INT	288	L1–L2 voltage N–4 (V)
Out_data[3]	INT	289	L2–L3 voltage N–4 (V)
Out_data[4]	INT	290	Voltage phase imbalance N–4 (%)
Out_data[5]	INT	291	Active power N–4 (kW)
Out_data[6]	INT	292	Power factor N–4 (x 0.01)
Out_data[7] ...Out_data[15]	–	–	Reserved

Custom_mdb_••••: Custom Read DFB for Modbus SL and Modbus/TCP

Presentation

The Custom_mdb_•••• DFBs are dedicated to the reading of up to 5 sets of registers in one single TeSys device through the Modbus SL or Modbus/TCP networks.

- Custom_mdb_addr uses XWAY addressing and is dedicated to Premium PLCs.
- Custom_mdb_addm uses an addressing method dedicated to M340 PLCs.

The Custom_mdb_•••• DFBs complete the Special_mdb_u_•••• and Special_mdb_t_•••• DFBs and enable the user to select the registers to read.

Characteristics

Characteristic	Value	
Name	Custom_mdb_addr	Custom_mdb_addm
Version	1.00 and 1.10	1.00 and 1.10
Input	3	3
Output	3	3
Input/Output	0	0
Public Variable	13	15

Graphical Representation

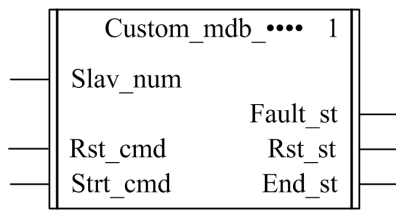

TeSys U and TeSys T Compliance

- TeSys U: The Custom_mdb_•••• DFBs are compliant with the following TeSys U sub-assemblies:
 - LUB•• non-reversing power base and LU2B•• reversing power base (up to 32 A/15 kW or 20 hp)
 - LUCM multifunction control unit
 - LULC033 Modbus communication module
- TeSys T: The Custom_mdb_•••• DFBs are compliant with all the LTM R•M•• and LTM R•E•• controller versions, with or without the LTM E expansion module.

Software Implementation

- The parameters and the inputs can only be changed if the End_st output variable is set to 1.
- With version 1.00:
 - The output data is only valid if the End_st output variable is set to 1 and if there is no fault detected (Fault_st = 0).
- With version 1.10:
 - The output data is only valid if there is no fault detected (Fault_st = 0).
 - Prog_num input can be modified on the fly.
- The public variables enable the user to read up to 5 sets of registers of a maximum length of 16 registers for each set:
 - The user defines the starting point of a set of registers with the In_reg public variable.
 - The user defines the length of the set of registers with the corresponding In_len public variable.
 - The registers content is then returned in the corresponding Out_dat public variable.

Input Characteristics

The following table describes the DFB inputs:

Input	Type	Range	Default Value	Description
Slav_num	INT	1...31	1	Modbus slave number
Rst_cmd	EBOOL	0...1	0	Reset command
Strt_cmd	EBOOL	0...1	0	Start command

Output Characteristics

The following table describes the DFB outputs:

Output	Type	Range	Default Value	Description
Fault_st	EBOOL	0...1	0	Fault detected
Rst_st	EBOOL	0...1	0	Reset state
End_st	EBOOL	0...1	0	End state

Public Variables Characteristics

The following table describes the Custom_mdb_addr DFB public variables (using XWAY addressing):

Public Variable	Type	Range	Default Value	Description
Net_num	INT	0...255	0	Network address
Stat_num	INT	0...255	0	Station address
Rack_num	INT	0...7	0	Destination rack address
Slot_num	INT	0...10	0	Destination slot address
Chan_num	INT	0...1	0	Destination channel address
In_reg	ARRAY[0...4] of INT	0...65535	0	Array of 5 words for the 5 index registers (In_reg[0]...In_reg[4])
In_len	ARRAY[0...4] of INT	0...16	0	Array of 5 words for the length of each set of registers (In_len[0]...In_len[4])
Out_dat[0]	ARRAY[0...15] of INT	0...65535	0	Array of up to 16 words containing the In_len[0] words starting from In_reg[0]
Out_dat[1]	ARRAY[0...15] of INT	0...65535	0	Array of up to 16 words containing the In_len[1] words starting from In_reg[1]
Out_dat[2]	ARRAY[0...15] of INT	0...65535	0	Array of up to 16 words containing the In_len[2] words starting from In_reg[2]
Out_dat[3]	ARRAY[0...15] of INT	0...65535	0	Array of up to 16 words containing the In_len[3] words starting from In_reg[3]
Out_dat[4]	ARRAY[0...15] of INT	0...65535	0	Array of up to 16 words containing the In_len[4] words starting from In_reg[4]
Sq_princ	INT	0...7	0	Reserved for support

The following table describes the Custom_mdb_adm DFB public variables (using M340 addressing):

Public Variable	Type	Range	Default Value	Description
Rack_num	INT	0...7	0	Destination rack address
Slot_num	INT	0...10	0	Destination slot address
Chan_num	INT	0...1	0	Destination channel address
IP_addr1	INT	0...255	0	First byte of IP address
IP_addr2	INT	0...255	0	Second byte of IP address
IP_addr3	INT	0...255	0	Third byte of IP address
IP_addr4	INT	0...255	0	Fourth byte of IP address
In_reg	ARRAY[0...4] of INT	0...65535	0	Array of 5 words for the 5 index registers (In_reg[0]...In_reg[4])

Public Variable	Type	Range	Default Value	Description
In_len	ARRAY[0...4] of INT	0...16	0	Array of 5 words for the length of each set of registers (In_len[0]...In_len[4])
Out_dat[0]	ARRAY[0...15] of INT	0...255	0	Array of up to 16 words containing the In_len[0] words starting from In_reg[0]
Out_dat[1]	ARRAY[0...15] of INT	0...255	0	Array of up to 16 words containing the In_len[1] words starting from In_reg[1]
Out_dat[2]	ARRAY[0...15] of INT	0...255	0	Array of up to 16 words containing the In_len[2] words starting from In_reg[2]
Out_dat[3]	ARRAY[0...15] of INT	0...65535	0	Array of up to 16 words containing the In_len[3] words starting from In_reg[3]
Out_dat[4]	ARRAY[0...15] of INT	0...65535	0	Array of up to 16 words containing the In_len[4] words starting from In_reg[4]
Sq_princ	INT	0...7	0	Reserved for support

Chapter 4

Modbus/TCP DFB for Quantum PLC

Introduction

This chapter describes the TeSys U and TeSys T Modbus/TCP DFBs dedicated to Quantum PLC.

What Is in This Chapter?

This chapter contains the following topics:

Topic	Page
Special_mdb_u_addq: TeSys U DFB for Modbus/TCP for Quantum PLC	62
Special_mdb_t_addq: TeSys T DFB for Modbus/TCP for Quantum PLC	68
Custom_mdb_addq: Custom Read DFB for Modbus/TCP for Quantum PLC	78

Special_mdb_u_addq: TeSys U DFB for Modbus/TCP for Quantum PLC

Presentation

The Special_mdb_u_addq DFBs are dedicated to the reading of up to 16 predefined registers of a TeSys U starter-controller (up to 32 A/15 kW or 20 hp) equipped with a LUCM multifunction control unit and a LULC033 Modbus communication module through an Ethernet gateway with a Modbus/TCP network connected to a Quantum PLC.

For more information, see the *TeSys U LULC032-033 Modbus Communication Module User Manual*.

Characteristics

Characteristic	Value
Name	Special_mdb_u_addq
Version	1.00
Input	4
Output	5
Input/Output	0
Public Variable	7

Graphical Representation

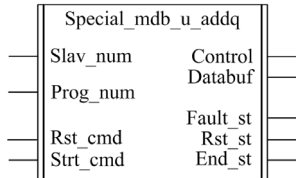

TeSys U Compliance

The Special_mdb_u_addq DFBs are compliant with the following TeSys U sub-assemblies:

Power base	<ul style="list-style-type: none"> ● LUB** non-reversing power base (up to 32 A/15 kW or 20 hp) ● LU2B** reversing power base (up to 32 A/15 kW or 20 hp)
Control unit	<ul style="list-style-type: none"> ● LUCM multifunction control unit
Communication module	<ul style="list-style-type: none"> ● LULC033 Modbus communication module connected through an Ethernet gateway

Software Implementation

- The parameters and the inputs can only be changed if the End_st output variable is set to 1.
- The output data is only valid if there is no fault detected (Fault_st = 0).
- Prog_num input can be modified on the fly.

Input Characteristics

The following table describes the DFB inputs:

Input	Type	Range	Default Value	Description
Slav_num	INT	1...31	1	Modbus address of the slave connected to the gateway
Prog_num	INT	0...6	0	Program number See <i>Program Number</i> , page 41
Rst_cmd	EBOOL	0...1	0	Reset command
Strt_cmd	EBOOL	0...1	0	Start command

Output Characteristics

The following table describes the DFB outputs:

Output	Type	Range	Default Value	Description
Control	ARRAY [1...9] of INT	0...65535	0	For internal use of the DFB. Must be linked to an array of 9 located words (%MW)
Databuf	ANY_ARRAY_INT	0...65535	0	For internal use of the DFB. Must be linked to an array of 38 located words minimum (%MW)
Fault_st	EBOOL	0...1	0	Fault detected
Rst_st	EBOOL	0...1	0	Reset state
End_st	EBOOL	0...1	0	End state

Program Number

The Prog_num input variable enables the user to define the public variables data depending on the application type. Each program uses variables related to one application (diagnostic, maintenance, measurement,...). The following table describes the programs of the DFB:

Program Number	Description
0	Bypass: no action
1	Diagnostic: faults monitoring variables, warnings monitoring variables, and communication monitoring variables
2	Maintenance: global statistics variables
3	Measurements: measurements monitoring variables
4	Statistics: last trip statistics and trip N-1 statistics
5	Statistics: trip N-2 statistics and trip N-3 statistics
6	Statistics: trip N-4 statistics

Public Variables Characteristics

The following table describes the Special_mdb_u_addq DFB public variables (using Quantum addressing):

Public Variable	Type	Range	Default Value	Description
Slot_num	INT	0...254	0	Slot address of the NOE coupler. Must be equal to 254 if using integrated Ethernet port of the CPU.
IP_addr1	INT	0...255	0	First byte of IP address
IP_addr2	INT	0...255	0	Second byte of IP address
IP_addr3	INT	0...255	0	Third byte of IP address
IP_addr4	INT	0...255	0	Fourth byte of IP address
Sq_princ	INT	0...7	0	Reserved for support
Out_data[0]...[15]	ARRAY [0...15] of INT	0...65535	0	The output data depends on the program number. See <i>Out_data[0]...[15] Public Variable (Program 1)</i> , page 42 ... <i>Out_data[0]...[15] Public Variable (Program 6)</i> , page 45

Out_data[0]...[15] Public Variable (Program 1)

The following table describes the Out_data[0]...[15] public variable in the case of the diagnostic program (program number 1):

Public Variable	Type	Register	Bit	Description
Out_data[0]	INT	452	0	Short-circuit fault
			1	Magnetic fault
			2	Ground fault
			3	Thermal fault
			4	Long start fault
			5	Jam fault
			6	Phase imbalance fault
			7	Underload fault
			8	Shunt trip fault
			9	Test trip fault
			10	Communication loss fault on LUCM Modbus port
			11	Control unit internal fault
			12	Module identification or internal communication fault
			13	Module internal fault
			14	Module trip fault
15	Module drop-out fault			
Out_data[1]	INT	461	0...1	Not significant
			2	Ground fault warning
			3	Thermal warning
			4	Long start warning
			5	Jam warning
			6	Phase imbalance warning
			7	Under-current warning
			8...9	Not significant
			10	Communication loss fault on LUCM Modbus port
			11	Internal temperature warning
			12	Module identification or internal communication warning
			13...14	Not significant
15	Module warning			
Out_data[2]	INT	457	0	Button position On (0 = Off)
			1	Button position Trip (0 = Not tripped)
			2	Contactactor state On
			3	24 Vdc power supply present on outputs
			4...15	Not significant
Out_data[3]	INT	450	–	Time to automatic reset on a thermal fault (s)
Out_data[4] ...Out_data[15]	–	–	–	Not significant

Out_data[0]...[15] Public Variable (Program 2)

The following table describes the Out_data[0]...[15] public variable in the case of the maintenance program (program number 2):

Public Variable	Type	Register	Description
Out_data[0]	INT	100	Short-circuit faults count
Out_data[1]	INT	101	Magnetic faults count
Out_data[2]	INT	102	Ground faults count
Out_data[3]	INT	103	Thermal faults count
Out_data[4]	INT	104	Long start faults count
Out_data[5]	INT	105	Jam faults count
Out_data[6]	INT	106	Phase imbalance faults count
Out_data[7]	INT	108	Shunt trip faults count
Out_data[8]	INT	115	Auto-resets count
Out_data[9]	INT	116	Thermal warnings count
Out_data[10]	INT	117	Starts count (LSB)
Out_data[11]	INT	118	Starts count (MSB)
Out_data[12]	INT	119	Operating time (LSB)
Out_data[13]	INT	120	Operating time (MSB)
Out_data[14]	INT	121	Maximum internal temperature (°C)
Out_data[15]	–	–	Not significant

Out_data[0]...[15] Public Variable (Program 3)

The following table describes the Out_data[0]...[15] public variable in the case of the measurements program (program number 3):

Public Variable	Type	Register	Description
Out_data[0]	–	–	Not significant
Out_data[1]	INT	465	Thermal capacity level (%)
Out_data[2]	INT	466	Average motor current (x 0.1 % FLA)
Out_data[3]	INT	467	L1 current (% FLA)
Out_data[4]	INT	468	L2 current (% FLA)
Out_data[5]	INT	469	L3 current (% FLA)
Out_data[6]	INT	470	Ground current (% FLA min)
Out_data[7]	INT	471	Current imbalance coefficient
Out_data[8]	INT	472	Control unit internal temperature (°C)
Out_data[9] ...Out_data[13]	–	–	Not significant
Out_data[14]	INT	79	Control unit sensor maximum current (x 0.1 A): <ul style="list-style-type: none"> ● 6 = adjustment range 0.15–0.6 A ● 14 = adjustment range 0.35–.4 A ● 50 = adjustment range 1.25–5 A ● 120 = adjustment range 3–12 A ● 180 = adjustment range 4.5–18 A ● 320 = adjustment range 8–32 A
Out_data[15]	INT	652	Full load amps setting (% FLA max): <ul style="list-style-type: none"> ● minimum = 25 (default value) ● maximum = 100

Out_data[0]...[15] Public Variable (Program 4)

The following table describes the Out_data[0]...[15] public variable in the case of the statistics program (program number 4):

Public Variable	Type	Register	Description
Out_data[0]	INT	150	Last trip fault number
Out_data[1]	INT	152	Last trip thermal capacity level (% trip level)
Out_data[2]	INT	153	Last trip average current (% FLA)
Out_data[3]	INT	154	Last trip L1 current (% FLA)
Out_data[4]	INT	155	Last trip L2 current (% FLA)
Out_data[5]	INT	156	Last trip L3 current (% FLA)
Out_data[6]	INT	157	Last trip ground current (% FLA min)
Out_data[7]	INT	180	N1 trip fault number
Out_data[8]	INT	182	N-1 trip thermal capacity level (% trip level)
Out_data[9]	INT	183	N-1 trip average current (% FLA)
Out_data[10]	INT	184	N-1 trip L1 current (% FLA)
Out_data[11]	INT	185	N-1 trip L2 current (%FLA)
Out_data[12]	INT	186	N-1 trip L3 current (% FLA)
Out_data[13]	INT	187	N-1 trip ground current (% FLA min)
Out_data[14]	INT	79	Control unit sensor maximum current (x 0.1 A): <ul style="list-style-type: none"> ● 6 = adjustment range 0.15–0.6 A ● 14 = adjustment range 0.35–1.4 A ● 50 = adjustment range 1.25–5 A ● 120 = adjustment range 3–12 A ● 180 = adjustment range 4.5–18 A ● 320 = adjustment range 8–32 A
Out_data[15]	INT	652	Full load amps setting (% FLA max): <ul style="list-style-type: none"> ● minimum = 25 (default value) ● maximum = 100

Out_data[0]...[15] Public Variable (Program 5)

The following table describes the Out_data[0]...[15] public variable in the case of the statistics program (program number 5):

Public Variable	Type	Register	Description
Out_data[0]	INT	210	N-2 trip fault number
Out_data[1]	INT	212	N-2 trip thermal capacity level (% trip level)
Out_data[2]	INT	213	N-2 trip average current (% FLA)
Out_data[3]	INT	214	N-2 trip L1 current (% FLA)
Out_data[4]	INT	215	N-2 trip L2 current (% FLA)
Out_data[5]	INT	216	N-2 trip L3 current (% FLA)
Out_data[6]	INT	217	N-2 trip ground current (% FLA min)
Out_data[7]	INT	240	N-3 trip fault number
Out_data[8]	INT	242	N-3 trip thermal capacity level (% trip level)
Out_data[9]	INT	243	N-3 trip average current (% FLA)
Out_data[10]	INT	244	N-3 trip L1 current (% FLA)
Out_data[11]	INT	245	N-3 trip L2 current (%FLA)
Out_data[12]	INT	246	N-3 trip L3 current (% FLA)
Out_data[13]	INT	247	N-3 trip ground current (% FLA min)
Out_data[14]	INT	79	Control unit sensor maximum current (x 0.1 A): <ul style="list-style-type: none"> ● 6 = adjustment range 0.15–0.6 A ● 14 = adjustment range 0.35–1.4 A ● 50 = adjustment range 1.25–5 A ● 120 = adjustment range 3–12 A ● 180 = adjustment range 4.5–18 A ● 320 = adjustment range 8–32 A
Out_data[15]	INT	652	Full load amps setting (% FLA max): <ul style="list-style-type: none"> ● minimum = 25 (default value) ● maximum = 100

Out_data[0]...[15] Public Variable (Program 6)

The following table describes the Out_data[0]...[15] public variable in the case of the statistics program (program number 6):

Public Variable	Type	Register	Description
Out_data[0]	INT	270	N-4 trip fault number
Out_data[1]	INT	272	N-4 trip thermal capacity level (% trip level)
Out_data[2]	INT	273	N-4 trip average current (% FLA)
Out_data[3]	INT	274	N-4 trip L1 current (% FLA)
Out_data[4]	INT	275	N-4 trip L2 current (% FLA)
Out_data[5]	INT	276	N-4 trip L3 current (% FLA)
Out_data[6]	INT	277	N-4 trip ground current (% FLA min)
Out_data[7] ...Out_data[13]	–	–	Reserved
Out_data[14]	INT	79	Control unit sensor maximum current (x 0.1 A): <ul style="list-style-type: none"> ● 6 = adjustment range 0.15–0.6 A ● 14 = adjustment range 0.35–1.4 A ● 50 = adjustment range 1.25–5 A ● 120 = adjustment range 3–12 A ● 180 = adjustment range 4.5–18 A ● 320 = adjustment range 8–32 A
Out_data[15]	INT	652	Full load amps setting (% FLA max): <ul style="list-style-type: none"> ● minimum = 25 (default value) ● maximum = 100

Special_mdb_t_addq: TeSys T DFB for Modbus/TCP for Quantum PLC

Presentation

The Special_mdb_t_addq DFBs are dedicated to the reading of up to 16 predefined registers of a TeSys T LTM R••E•• controller through the Modbus/TCP network connected to a Quantum PLC.

For more information, see the *TeSys T LTMR Ethernet Communication Guide*.

Characteristics

Characteristic	Value
Name	Special_mdb_t_addq
Version	1.00
Input	3
Output	5
Input/Output	0
Public Variable	7

Graphical Representation

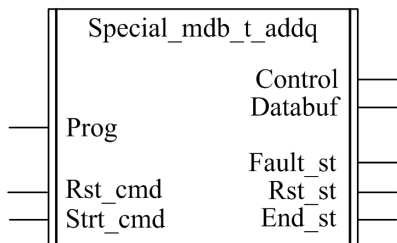

TeSys T Compliance

The Special_mdb_t_addq DFBs are compliant with all the LTM R••E•• controller versions, with or without the LTM E expansion module.

Software Implementation

- The parameters and the inputs can only be changed if the End_st output variable is set to 1.
- The output data is only valid if there is no fault detected (Fault_st = 0).
- Prog_num can be modified on the fly.

Input Characteristics

The following table describes the DFB inputs:

Input	Type	Range	Default Value	Description
Prog_num	INT	0...6	0	Program number See <i>Program Number</i> , page 47
Rst_cmd	EBOOL	0...1	0	Reset command
Strt_cmd	EBOOL	0...1	0	Start command

Output Characteristics

The following table describes the DFB outputs:

Output	Type	Range	Default Value	Description
Control	ARRAY [1...9] of INT	0...65535	0	For internal use of the DFB. Must be linked to an array of 9 located words (%MW)
Databuf	ANY_ARRAY_INT	0...65535	0	For internal use of the DFB. Must be linked to an array of 20 located words minimum (%MW)
Fault_st	EBOOL	0...1	0	Fault detected
Rst_st	EBOOL	0...1	0	Reset state
End_st	EBOOL	0...1	0	End state

Program Number

The Prog_num input variable enables the user to define the public variables data depending on the application type. Each program holds variables related to one application (diagnostic, maintenance, measurement,...). The following table describes the programs of the DFB:

Program Number	Description
0	Bypass: no action
10	Diagnostic: detected faults monitoring variables, detected warnings monitoring variables, and communication monitoring variables
20	Maintenance: global statistics variables
30	Measurements 1
31	Measurements 2
32	Measurements 3
40	Statistics: last detected fault (N-0) statistics
41	Statistics: last detected fault (N-0) statistics (with expansion module)
50	Statistics: N-1 detected fault statistics
51	Statistics: N-1 detected fault statistics (with expansion module)
60	Statistics: N-2 detected fault statistics
61	Statistics: N-2 detected fault statistics (with expansion module)
70	Statistics: N-3 detected fault statistics
71	Statistics: N-3 detected fault statistics (with expansion module)
80	Statistics: N-4 detected fault statistics
81	Statistics: N-4 detected fault statistics (with expansion module)

Public Variables Characteristics

The following table describes the Special_mdb_t_addq DFB public variables (using Quantum addressing):

Public Variable	Type	Range	Default Value	Description
Slot_num	INT	0...254	0	Slot address of the NOE coupler. Must be equal to 254 if using integrated Ethernet port of the CPU.
IP_addr1	INT	0...255	0	First byte of IP address
IP_addr2	INT	0...255	0	Second byte of IP address
IP_addr3	INT	0...255	0	Third byte of IP address
IP_addr4	INT	0...255	0	Fourth byte of IP address
Sq_princ	INT	0...7	0	Reserved for support
Out_data[0]...[15]	ARRAY [0...15] of INT	0...65535	0	The output data depends on the program number. See <i>Out_data[0]...[15] Public Variable (Program 1), page 42...Out_data[0]...[15] Public Variable (Program 6), page 45</i>

Out_data[0]...[15] Public Variable (Program 10)

The following table describes the Out_data[0]...[15] public variable in the case of the diagnostic program (program number 10):

Public Variable	Type	Register	Bit	Description
Out_data[0]	INT	452	0...1	Reserved
			2	Ground current fault
			3	Thermal overload fault
			4	Long start fault
			5	Jam fault
			6	Current phase imbalance fault
			7	Undercurrent fault
			8	Reserved
			9	Test fault (the TeSys T controller has detected a fault during a self test sequence)
			10	HMI port fault
			11	Controller internal fault
			12	Internal port fault
			13	Reserved
			14	Network port config fault
			15	Network port fault
Out_data[1]	INT	453	0	External fault (fault detected by external device and connected to I.3)
			1	Diagnostic fault
			2	Wiring fault
			3	Overcurrent fault
			4	Current phase loss fault
			5	Current phase reversal fault
			6	Motor temperature sensor fault (1)
			7	Voltage phase imbalance fault (1)
			8	Voltage phase loss fault (1)
			9	Voltage phase reversal fault (1)
			10	Undervoltage fault (1)
			11	Overvoltage fault (1)
			12	Underpower fault (1)
			13	Overpower fault (1)
			14	Under power factor fault (1)
15	Over power factor fault (1)			
Out_data[2]	INT	461	0...1	Reserved
			2	Ground current warning
			3	Thermal overload warning
			4	Reserved
			5	Jam warning
			6	Current phase imbalance warning
			7	Undercurrent warning
			8...9	Reserved
			10	HMI port warning
			11	Controller internal temperature warning
			12...14	Reserved
			15	Network port warning

Public Variable	Type	Register	Bit	Description
Out_data[3]	INT	462	0	Reserved
			1	Diagnostic warning
			2	Reserved
			3	Overcurrent warning
			4	Current phase loss warning
			5	Current phase reversal warning
			6	Motor temperature sensor warning
			7	Voltage phase imbalance warning (1)
			8	Voltage phase loss warning (1)
			9	Reserved
			10	Undervoltage warning (1)
			11	Overvoltage warning (1)
			12	Underpower warning (1)
			13	Overpower warning (1)
			14	Under power factor warning (1)
			15	Over power factor warning (1)
Out_data[4]	INT	457	0	Logic input 1
			1	Logic input 2
			2	Logic input 3
			3	Logic input 4
			4	Logic input 5
			5	Logic input 6
			6	Logic input 7
			7	Logic input 8 (1)
			8	Logic input 9 (1)
			9	Logic input 10 (1)
			10	Logic input 11 (1)
			11	Logic input 12 (1)
			12	Logic input 13 (1)
			13	Logic input 14 (1)
			14	Logic input 15 (1)
			15	Logic input 16 (1)
Out_data[5]	INT	458	0	Logic output 1
			1	Logic output 2
			2	Logic output 3
			3	Logic output 4
			4	Logic output 5 (1)
			5	Logic output 6 (1)
			6	Logic output 7 (1)
			7	Logic output 8 (1)
			8...15	Reserved
Out_data[6]	INT	450	–	Minimum wait time (s)
Out_data[7] ...Out_data[15]	–	–	–	Reserved
(1) The variable is available for the LTM R controller and the LTM EV40 expansion module combination.				

Out_data[0]...[15] Public Variable (Program 20)

The following table describes the Out_data[0]...[15] public variable in the case of the maintenance program (program number 20):

Public Variable	Type	Register	Description
Out_data[0]	INT	102	Ground current faults count
Out_data[1]	INT	103	Thermal overload faults count
Out_data[2]	INT	104	Long start faults count
Out_data[3]	INT	105	Jam faults count
Out_data[4]	INT	106	Current phase imbalance faults count
Out_data[5]	INT	107	Undercurrent faults count
Out_data[6]	–	–	Reserved
Out_data[7]	INT	114	Network port faults count
Out_data[8]	INT	115	Auto-resets count
Out_data[9]	INT	116	Thermal overload warnings count
Out_data[10]	INT	117	Motor starts count (LSB)
Out_data[11]	INT	118	Motor starts count (MSB)
Out_data[12]	INT	119	Operating time (s) (LSB)
Out_data[13]	INT	120	Operating time (MSB)
Out_data[14]	INT	121	Maximum controller internal temperature (°C)
Out_data[15]	–	–	Reserved

Out_data[0]...[15] Public Variable (Program 30)

The following table describes the Out_data[0]...[15] public variable in the case of the first measurements program (program number 30):

Public Variable	Type	Register	Description
Out_data[0]	–	–	Reserved
Out_data[1]	INT	465	Thermal capacity level (% trip level)
Out_data[2]	INT	466	Average current ratio (% FLC)
Out_data[3]	INT	467	L1 current ratio (% FLC)
Out_data[4]	INT	468	L2 current ratio (% FLC)
Out_data[5]	INT	469	L3 current ratio (% FLC)
Out_data[6]	INT	470	Ground current ratio (x 0.1% FLC min)
Out_data[7]	INT	471	Current phase imbalance (%)
Out_data[8]	INT	472	Controller internal temperature (°C)
Out_data[9]	INT	474	Frequency (x 0.01 Hz)
Out_data[10]	INT	475	Motor temperature sensor (x 0.1 Ω)
Out_data[11] ...Out_data[13]	–	–	Reserved
Out_data[14]	INT	96	Full load current (FLC) max (x 0.1 A)
Out_data[15]	INT	652	Motor full load current ratio

Out_data[0]...[15] Public Variable (Program 31)

The following table describes the Out_data[0]...[15] public variable in the case of the second measurements program (program number 31):

Public Variable	Type	Register	Description
Out_data[0]	INT	500	Average current (x 0.01 A) MSB
Out_data[1]	INT	501	Average current (x 0.01 A) LSB
Out_data[2]	INT	502	L1 current (x 0.01 A) MSB
Out_data[3]	INT	503	L1 current (x 0.01 A) LSB
Out_data[4]	INT	504	L2 current (x 0.01 A) MSB
Out_data[5]	INT	505	L2 current (x 0.01 A) LSB
Out_data[6]	INT	506	L3 current (x 0.01 A) MSB
Out_data[7]	INT	507	L3 current (x 0.01 A) LSB
Out_data[8]	INT	508	Ground current (x 0.001 A) MSB
Out_data[9]	INT	509	Ground current (x 0.001 A) LSB
Out_data[10]	INT	511	Time to trip (x 1 s)
Out_data[11]	INT	512	Motor last start current ratio (% FLC)
Out_data[12]	INT	513	Motor last start duration (s)
Out_data[13]	INT	514	Motor starts per hour count
Out_data[14] ...Out_data[15]	-	-	-

Out_data[0]...[15] Public Variable (Program 32)

The following table describes the Out_data[0]...[15] public variable in the case of the third measurements program (program number 32):

Public Variable	Type	Register	Description
Out_data[0]	WORD	476	Average voltage (V)
Out_data[1]	WORD	477	L3-L1 voltage (V)
Out_data[2]	WORD	478	L1-L2 voltage (V)
Out_data[3]	WORD	479	L2-L3 voltage (V)
Out_data[4]	WORD	480	Voltage phase imbalance (%)
Out_data[5]	WORD	481	Power factor (x 0.01)
Out_data[6]	WORD	482	Active power (x 0.1 kW)
Out_data[7]	WORD	483	Reactive power (x 0.1 kVAr)
Out_data[8] ...Out_data[15]	-	-	Reserved

Out_data[0]...[15] Public Variable (Program 40)

The following table describes the Out_data[0]...[15] public variable in the case of the last detected fault statistics program (program number 40):

Public Variable	Type	Register	Description
Out_data[0]	INT	150	Detected fault code N-0
Out_data[1]	INT	151	Motor full load current ratio N-0 (% FLC max)
Out_data[2]	INT	152	Thermal capacity level N-0 (% trip level)
Out_data[3]	INT	153	Average current ratio N-0 (% FLC)
Out_data[4]	INT	154	L1 current ratio N-0 (% FLC)
Out_data[5]	INT	155	L2 current ratio N-0 (% FLC)
Out_data[6]	INT	156	L3 current ratio N-0 (% FLC)
Out_data[7]	INT	157	Ground current ratio N-0 (x 0.1% FLC min)
Out_data[8]	INT	158	Full load current max N-0 (x 0.1 A)
Out_data[9]	INT	159	Current phase imbalance N-0 (%)
Out_data[10]	INT	160	Frequency N-0 (x 0.1 Hz)

Public Variable	Type	Register	Description
Out_data[11]	INT	161	Motor temperature sensor N-0 (x 0.1 Ω)
Out_data[12]	WORD[4]	162	Date and time N-0
Out_data[13]		163	See <i>DT_DateTime</i> , page 111
Out_data[14]		164	
Out_data[15]		165	

Out_data[0]...[15] Public Variable (Program 41)

The following table describes the Out_data[0]...[15] public variable in the case of the last detected fault statistics with expansion module program (program number 41):

Public Variable	Type	Register	Description
Out_data[0]	INT	166	Average voltage N-0 (V)
Out_data[1]	INT	167	L3-L1 voltage N-0 (V)
Out_data[2]	INT	168	L1-L2 voltage N-0 (V)
Out_data[3]	INT	169	L2-L3 voltage N-0 (V)
Out_data[4]	INT	170	Voltage phase imbalance N-0 (%)
Out_data[5]	INT	171	Active power N-0 (kW)
Out_data[6]	INT	172	Power factor N-0 (x 0.01)
Out_data[7] ...Out_data[15]	-	-	Reserved

Out_data[0]...[15] Public Variable (Program 50)

The following table describes the Out_data[0]...[15] public variable in the case of the N-1 detected fault statistics program (program number 50):

Public Variable	Type	Register	Description
Out_data[0]	INT	180	Detected fault code N-1
Out_data[1]	INT	181	Motor full load current ratio N-1 (% FLC max)
Out_data[2]	INT	182	Thermal capacity level N-1 (% trip level)
Out_data[3]	INT	183	Average current ratio N-1 (% FLC)
Out_data[4]	INT	184	L1 current ratio N-1 (% FLC)
Out_data[5]	INT	185	L2 current ratio N-1 (% FLC)
Out_data[6]	INT	186	L3 current ratio N-1 (% FLC)
Out_data[7]	INT	187	Ground current ratio N-1 (x 0.1% FLC min)
Out_data[8]	INT	188	Full load current max N-1 (x 0.1 A)
Out_data[9]	INT	189	Current phase imbalance N-1 (%)
Out_data[10]	INT	190	Frequency N-1 (x 0.1 Hz)
Out_data[11]	INT	191	Motor temperature sensor N-1 (x 0.1 Ω)
Out_data[12]	WORD[4]	192	Date and time N-1
Out_data[13]		193	See <i>DT_DateTime</i> , page 111
Out_data[14]		194	
Out_data[15]		195	

Out_data[0]...[15] Public Variable (Program 51)

The following table describes the Out_data[0]...[15] public variable in the case of the N–1 detected fault statistics with expansion module program (program number 51):

Public Variable	Type	Register	Description
Out_data[0]	INT	196	Average voltage N–1 (V)
Out_data[1]	INT	197	L3–L1 voltage N–1 (V)
Out_data[2]	INT	198	L1–L2 voltage N–1 (V)
Out_data[3]	INT	199	L2–L3 voltage N–1 (V)
Out_data[4]	INT	200	Voltage phase imbalance N–1 (%)
Out_data[5]	INT	201	Active power N–1 (kW)
Out_data[6]	INT	202	Power factor N–1 (x 0.01)
Out_data[7] ...Out_data[15]	–	–	Reserved

Out_data[0]...[15] Public Variable (Program 60)

The following table describes the Out_data[0]...[15] public variable in the case of the N–2 detected fault statistics program (program number 60):

Public Variable	Type	Register	Description
Out_data[0]	INT	210	Detected fault code N–2
Out_data[1]	INT	211	Motor full load current ratio N–2 (% FLC max)
Out_data[2]	INT	212	Thermal capacity level N–2 (% trip level)
Out_data[3]	INT	213	Average current ratio N–2 (% FLC)
Out_data[4]	INT	214	L1 current ratio N–2 (% FLC)
Out_data[5]	INT	215	L2 current ratio N–2 (% FLC)
Out_data[6]	INT	216	L3 current ratio N–2 (% FLC)
Out_data[7]	INT	217	Ground current ratio N–2 (x 0.1% FLC min)
Out_data[8]	INT	218	Full load current max N–2 (x 0.1 A)
Out_data[9]	INT	219	Current phase imbalance N–2 (%)
Out_data[10]	INT	220	Frequency N–2 (x 0.1 Hz)
Out_data[11]	INT	221	Motor temperature sensor N–2 (x 0.1 Ω)
Out_data[12]	WORD[4]	222	Date and time N–2 See <i>DT_DateTime</i> , page 111
Out_data[13]		223	
Out_data[14]		224	
Out_data[15]		225	

Out_data[0]...[15] Public Variable (Program 61)

The following table describes the Out_data[0]...[15] public variable in the case of the N–2 detected fault statistics with expansion module program (program number 61):

Public Variable	Type	Register	Description
Out_data[0]	INT	226	Average voltage N–2 (V)
Out_data[1]	INT	227	L3–L1 voltage N–2 (V)
Out_data[2]	INT	228	L1–L2 voltage N–2 (V)
Out_data[3]	INT	229	L2–L3 voltage N–2 (V)
Out_data[4]	INT	230	Voltage phase imbalance N–2 (%)
Out_data[5]	INT	231	Active power N–2 (kW)
Out_data[6]	INT	232	Power factor N–2 (x 0.01)
Out_data[7] ...Out_data[15]	–	–	Reserved

Out_data[0]...[15] Public Variable (Program 70)

The following table describes the Out_data[0]...[15] public variable in the case of the N–3 detected fault statistics program (program number 70):

Public Variable	Type	Register	Description
Out_data[0]	INT	240	Detected fault code N–3
Out_data[1]	INT	241	Motor full load current ratio N–3 (% FLC max)
Out_data[2]	INT	242	Thermal capacity level N–3 (% trip level)
Out_data[3]	INT	243	Average current ratio N–3 (% FLC)
Out_data[4]	INT	244	L1 current ratio N–3 (% FLC)
Out_data[5]	INT	245	L2 current ratio N–3 (% FLC)
Out_data[6]	INT	246	L3 current ratio N–3 (% FLC)
Out_data[7]	INT	247	Ground current ratio N–3 (x 0.1% FLC min)
Out_data[8]	INT	248	Full load current max N–3 (x 0.1 A)
Out_data[9]	INT	249	Current phase imbalance N–3 (%)
Out_data[10]	INT	250	Frequency N–3 (x 0.1 Hz)
Out_data[11]	INT	251	Motor temperature sensor N–3 (x 0.1 Ω)
Out_data[12]	WORD[4]	252	Date and time N–3
Out_data[13]		253	See <i>DT_DateTime</i> , page 111
Out_data[14]		254	
Out_data[15]		255	

Out_data[0]...[15] Public Variable (Program 71)

The following table describes the Out_data[0]...[15] public variable in the case of the N–3 detected fault statistics with expansion module program (program number 71):

Public Variable	Type	Register	Description
Out_data[0]	INT	256	Average voltage N–3 (V)
Out_data[1]	INT	257	L3–L1 voltage N–3 (V)
Out_data[2]	INT	258	L1–L2 voltage N–3 (V)
Out_data[3]	INT	259	L2–L3 voltage N–3 (V)
Out_data[4]	INT	260	Voltage phase imbalance N–3 (%)
Out_data[5]	INT	261	Active power N–3 (kW)
Out_data[6]	INT	262	Power factor N–3 (x 0.01)
Out_data[7] ...Out_data[15]	–	–	Reserved

Out_data[0]...[15] Public Variable (Program 80)

The following table describes the Out_data[0]...[15] public variable in the case of the N-4 detected fault statistics program (program number 80):

Public Variable	Type	Register	Description
Out_data[0]	INT	270	Detected fault code N-4
Out_data[1]	INT	271	Motor full load current ratio N-4 (% FLC max)
Out_data[2]	INT	272	Thermal capacity level N-4 (% trip level)
Out_data[3]	INT	273	Average current ratio N-4 (% FLC)
Out_data[4]	INT	274	L1 current ratio N-4 (% FLC)
Out_data[5]	INT	275	L2 current ratio N-4 (% FLC)
Out_data[6]	INT	276	L3 current ratio N-4 (% FLC)
Out_data[7]	INT	277	Ground current ratio N-4 (x 0.1% FLC min)
Out_data[8]	INT	278	Full load current max N-4 (x 0.1 A)
Out_data[9]	INT	279	Current phase imbalance N-4 (%)
Out_data[10]	INT	280	Frequency N-4 (x 0.1 Hz)
Out_data[11]	INT	281	Motor temperature sensor N-4 (x 0.1 Ω)
Out_data[12]	WORD[4]	282	Date and time N-4
Out_data[13]		283	See <i>DT_DateTime</i> , page 111
Out_data[14]		284	
Out_data[15]		285	

Out_data[0]...[15] Public Variable (Program 81)

The following table describes the Out_data[0]...[15] public variable in the case of the N-4 detected fault statistics with expansion module program (program number 81):

Public Variable	Type	Register	Description
Out_data[0]	INT	286	Average voltage N-4 (V)
Out_data[1]	INT	287	L3-L1 voltage N-4 (V)
Out_data[2]	INT	288	L1-L2 voltage N-4 (V)
Out_data[3]	INT	289	L2-L3 voltage N-4 (V)
Out_data[4]	INT	290	Voltage phase imbalance N-4 (%)
Out_data[5]	INT	291	Active power N-4 (kW)
Out_data[6]	INT	292	Power factor N-4 (x 0.01)
Out_data[7] ...Out_data[15]	-	-	Reserved

Custom_mdb_addq: Custom Read DFB for Modbus/TCP for Quantum PLC

Presentation

The Custom_mdb_addq DFB is dedicated to the reading of up to 5 sets of registers in one single TeSys device through the Modbus/TCP network connected to a Quantum PLC.

The Custom_mdb_addq DFB completes the Special_mdb_u_addq and Special_mdb_t_addq DFBs and enable the user to select the registers to read.

Characteristics

Characteristic	Value
Name	Custom_mdb_addq
Version	1.00
Input	3
Output	5
Input/Output	0
Public Variable	13

Graphical Representation

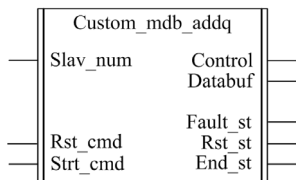

TeSys U and TeSys T Compliance

- TeSys U: The Custom_mdb_addq DFB is compliant with the following TeSys U sub-assemblies:
 - LUB** non-reversing power base and LU2B** reversing power base (up to 32 A/15 kW or 20 hp)
 - LUCM multifunction control unit
 - LULC033 Modbus communication module connected through an Ethernet gateway.
- TeSys T: The Custom_mdb_addq DFB is compliant with all the LTM R**M** (through an Ethernet gateway) and LTM R**E** controller versions, with or without the LTM E expansion module.

Software Implementation

- The parameters and the inputs can only be changed if the End_st output variable is set to 1.
- The output data is only valid if there is no fault detected (Fault_st = 0).
- Prog_num input can be modified on the fly.
- The public variables enable the user to read up to 5 sets of registers of a maximum length of 16 registers for each set:
 - The user defines the starting point of a set of registers with the In_reg public variable.
 - The user defines the length of the set of registers with the corresponding In_len public variable.
 - The registers content is then returned in the corresponding Out_dat public variable.

Input Characteristics

The following table describes the DFB inputs:

Input	Type	Range	Default Value	Description
Slav_num	INT	1...31	1	Modbus slave number
Rst_cmd	EBOOL	0...1	0	Reset command
Strt_cmd	EBOOL	0...1	0	Start command

Output Characteristics

The following table describes the DFB outputs:

Output	Type	Range	Default Value	Description
Control	ARRAY [1...9] of INT	0...65535	0	For internal use of the DFB. Must be linked to an array of 9 located words (%MW)
Databuf	ANY_ARRAY_INT	0...65535	0	For internal use of the DFB. Must be linked to an array of 16 located words minimum (%MW)
Fault_st	EBOOL	0...1	0	Fault detected
Rst_st	EBOOL	0...1	0	Reset state
End_st	EBOOL	0...1	0	End state

Public Variables Characteristics

The following table describes the Custom_mdb_addq DFB public variables (using Quantum addressing):

Public Variable	Type	Range	Default Value	Description
Slot_num	INT	0...254	0	Slot address of the NOE coupler. Must be equal to 254 if using integrated Ethernet port of the CPU.
IP_addr1	INT	0...255	0	First byte of IP address
IP_addr2	INT	0...255	0	Second byte of IP address
IP_addr3	INT	0...255	0	Third byte of IP address
IP_addr4	INT	0...255	0	Fourth byte of IP address
In_reg	ARRAY[0...4] of INT	0...65535	0	Array of 5 words for the 5 index registers (In_reg[0]...In_reg[4])
In_len	ARRAY[0...4] of INT	0...16	0	Array of 5 words for the length of each set of registers (In_len[0]...In_len[4])
Out_dat[0]	ARRAY[0...15] of INT	0...255	0	Array of up to 16 words containing the In_len[0] words starting from In_reg[0]
Out_dat[1]	ARRAY[0...15] of INT	0...255	0	Array of up to 16 words containing the In_len[1] words starting from In_reg[1]
Out_dat[2]	ARRAY[0...15] of INT	0...255	0	Array of up to 16 words containing the In_len[2] words starting from In_reg[2]
Out_dat[3]	ARRAY[0...15] of INT	0...65535	0	Array of up to 16 words containing the In_len[3] words starting from In_reg[3]
Out_dat[4]	ARRAY[0...15] of INT	0...65535	0	Array of up to 16 words containing the In_len[4] words starting from In_reg[4]
Sq_princ	INT	0...7	0	Reserved for support

Chapter 5

Profibus DFB

Introduction

This chapter describes the TeSys U and TeSys T Profibus DP DFBs.

What Is in This Chapter?

This chapter contains the following topics:

Topic	Page
Ctrl_pfb_u_ms: TeSys U Control/Command for Profibus DP MS	82
Ctrl_pfb_u_mms: TeSys U Control/Command for Profibus DP MMS	84
Ctrl_pfb_t_mms: TeSys T Control/Command for Profibus DP MMS	86

Ctrl_pfb_u_ms: TeSys U Control/Command for Profibus DP MS

Presentation

The Ctrl_pfb_u_ms DFB is dedicated to the control and command of a single TeSys U starter-controller through the Profibus DP MS (Motor Starter) network.

With the MS profile, the TeSys U starter-controller commands are managed on bit level. For more information, see the *TeSys U LULC07 Profibus DP Communication Module User Manual*.

Characteristics

Characteristic	Value
Name	Ctrl_pfb_u_ms
Version	1.00
Input	7
Output	10
Input/Output	0
Public Variable	0

Graphical Representation

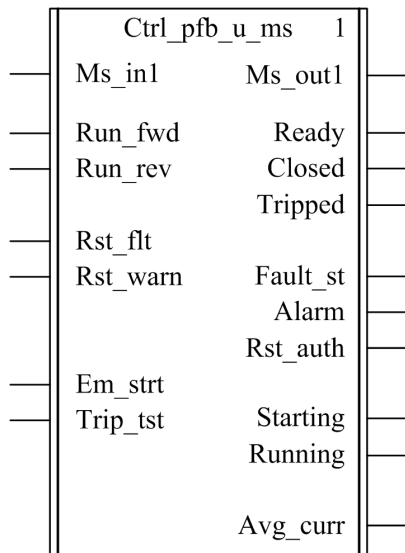

TeSys U Compliance

The Ctrl_pfb_u_ms DFB is compliant with the following TeSys U sub-assemblies:

Power base	<ul style="list-style-type: none"> ● LUB** non-reversing power base ● LU2B** reversing power base
Control unit	<ul style="list-style-type: none"> ● LUCA standard control unit ● LUCB and LUCD advanced control units ● LUCC advanced control unit (up to 32 A/15 kW or 20 hp) ● LUCL magnetic control unit ● LUCM multifunction control unit (up to 32 A/15 kW or 20 hp)
Communication module	<ul style="list-style-type: none"> ● LULC07 Profibus DP communication module
GSD file modules	<ul style="list-style-type: none"> ● Sc St R MS with or without PKW ● Sc Ad R MS with or without PKW ● Sc Mu R MS with or without PKW ● Sc Mu L MS with or without PKW

Software Implementation

- Ms_in1 input word must be linked to the first word of the Profibus slave input cyclic data.
- Ms_out1 output word must be linked to the first word of the Profibus slave output cyclic data.

Input Characteristics

The following table describes the DFB inputs and their availability according to the control unit:

Input	Type	Range	Default Value	Description	LUCA LUCL	LUCB LUCC LUCD	LUCM
Ms_in1	INT	–	0	Must be linked to the first word of the MS Profibus slave input cyclic data	√	√	√
Run_fwd	EBOOL	0...1	0	Motor run forward command	√	√	√
Run_rev	EBOOL	0...1	0	Motor run reverse command	√	√	√
Rst_ftt	EBOOL	0...1	0	Reset device (if register 451 = 102 or 104, fault acknowledgment causes a return to communication module factory settings)	√	√	√
Rst_warn	EBOOL	0...1	0	Reset warning (for example, communication loss)	√	√	√
Em_strt	EBOOL	0...1	0	Emergency start (reset thermal memory)	–	–	√
Trip_tst	EBOOL	0...1	0	Overcurrent trip test via communication bus	–	–	√

Output Characteristics

The following table describes the DFB outputs and their availability according to the control unit:

Output	Type	Range	Default Value	Description	LUCA LUCL	LUCB LUCC LUCD	LUCM
Ms_out1	INT	–	0	Must be linked to the first word of the MS Profibus slave output cyclic data	√	√	√
Ready	EBOOL	0...1	0	System ready: the rotary handle is turned to On position and there is no fault	√	√	√
Closed	EBOOL	0...1	0	Pole status: closed	√	√	√
Tripped	EBOOL	0...1	0	System tripped: the rotary handle is turned to Trip position	√	√	√
Fault	EBOOL	0...1	0	All faults	√	√	√
Alarm	EBOOL	0...1	0	All warnings	√	√	√
Rst_auth	EBOOL	0...1	0	Fault reset authorized	–	√	√
Starting	EBOOL	0...1	0	Start in progress: 1 = ascending current is greater than 10% FLA 0 = descending current is lower than 150% FLA	–	√	√
Running	EBOOL	0...1	0	Motor running with detection of current, if greater than 10% FLA	–	√	√
Avg_curr	INT	0...200	0	Average motor current (x 1% FLA)	–	√	√

Ctrl_pfb_u_mms: TeSys U Control/Command for Profibus DP MMS

Presentation

The Ctrl_pfb_u_mms DFB is dedicated to the control and command of a single TeSys U starter-controller (up to 32 A/15 kW or 20 hp) with a LUCM multifunction control unit and a LULC07 Profibus DP communication module through the Profibus DP MMS (Motor Management Starter) network.

With the MMS profile, the TeSys U starter-controller commands are managed on bit rising edges. For more information, see the *TeSys U LULC07 Profibus DP Communication Module User Manual*.

Characteristics

Characteristic	Value
Name	Ctrl_pfb_u_mms
Version	1.00
Input	10
Output	13
Input/Output	0
Public Variable	0

Graphical Representation

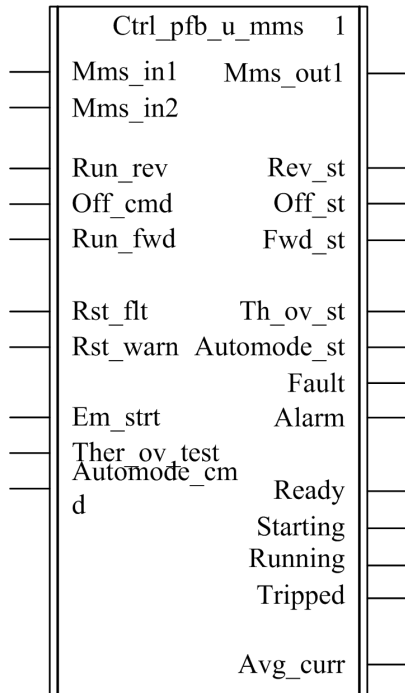

TeSys U Compliance

The Ctrl_pfb_u_mms DFB is compliant with the following TeSys U sub-assemblies:

Power base	<ul style="list-style-type: none"> • LUB** non-reversing power base (up to 32 A/15 kW or 20 hp) • LU2B** reversing power base (up to 32 A/15 kW or 20 hp)
Control unit	<ul style="list-style-type: none"> • LUCM multifunction control unit
Communication module	<ul style="list-style-type: none"> • LULC07 Profibus DP communication module
GSD file modules	<ul style="list-style-type: none"> • Sc Mu R MMS with or without PKW • Sc Mu L MMS with or without PKW

Software Implementation

- Mms_in1 and Mms_in2 input words must be linked to the first 2 words of the Profibus slave input cyclic data.
- Mms_out1 output word must be linked to the first word of the Profibus slave output cyclic data.

Input Characteristics

The following table describes the DFB inputs:

Input	Type	Range	Default Value	Description
Mms_in1	INT	–	0	Must be linked to the first word of the MMS Profibus slave input cyclic data
Mms_in2	INT	–	0	Must be linked to the second word of the MMS Profibus slave input cyclic data
Run_rev	EBOOL	0...1	0	Motor run reverse command
Off_cmd	EBOOL	0...1	0	Off command
Run_fwd	EBOOL	0...1	0	Motor run forward command
Rstflt	EBOOL	0...1	0	Reset device
Rst_warn	EBOOL	0...1	0	Reset warning
Em_strt	EBOOL	0...1	0	Emergency start (reset thermal memory)
Ther_ov_test	EBOOL	0...1	0	Thermal overload test
Automode_cmd	EBOOL	0...1	0	Auto mode command

Output Characteristics

The following table describes the DFB outputs:

Output	Type	Range	Default Value	Description
Ms_out1	INT	–	0	Must be linked to the first word of the Profibus slave output cyclic data
Rev_st	EBOOL	0...1	0	Run reverse
Off_st	EBOOL	0...1	0	System Off
Fwd_st	EBOOL	0...1	0	Run forward
Th_ov_st	EBOOL	0...1	0	Thermal overload
Automode_st	EBOOL	0...1	0	Auto mode
Fault	EBOOL	0...1	0	TeSys U on fault
Alarm	EBOOL	0...1	0	TeSys U on alarm
Ready	EBOOL	0...1	0	TeSys U ready to operate
Starting	EBOOL	0...1	0	Motor starting
Running	EBOOL	0...1	0	Motor running
Tripped	EBOOL	0...1	0	Rotary knob on trip position
Avg_curr	INT	0...2000	0	Average motor current (x 0.1% FLA)

Ctrl_pfb_t_mms: TeSys T Control/Command for Profibus DP MMS

Presentation

The Ctrl_pfb_t_mms DFB is dedicated to the control and command of a single TeSys T LTM R••P•• controller through the Profibus DP MMS (Motor Management Starter) network.

With the MMS profile, the TeSys T LTM R••P•• controller commands are managed on bit rising edges. For more information, see the *TeSys T LTMR Profibus DP Communication Guide*.

Characteristics

Characteristic	Value
Name	Ctrl_pfb_t_mms
Version	1.00
Input	11
Output	22
Input/Output	0
Public Variable	0

Graphical Representation

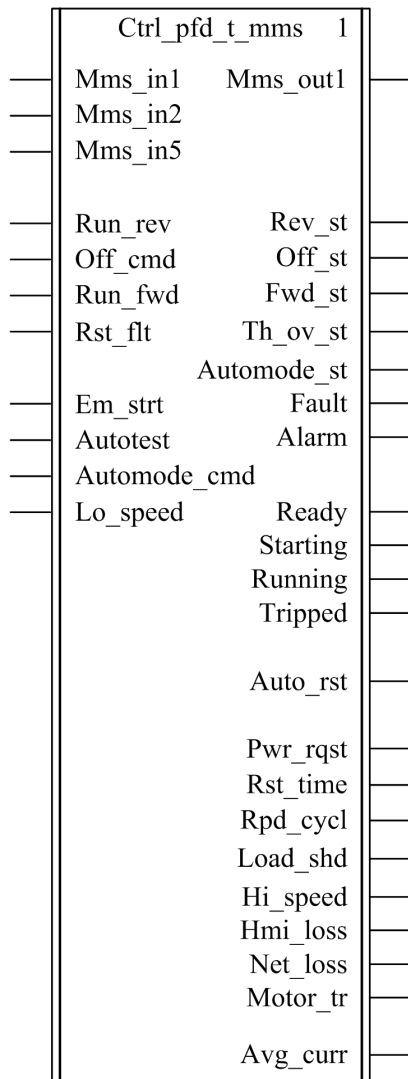

TeSys T Compliance

The Ctrl_pfb_t_mms DFB is compliant with all the TeSys T LTM R••P•• controller versions, with or without the LTM E expansion module.

Software Implementation

- Mms_in1, Mms_in2 and Mms_in5 input words must be linked respectively to the first, second, and fifth word of the Profibus slave input cyclic data.
- Mms_out1 output word must be linked to the first word of the Profibus slave output cyclic data.

Input Characteristics

The following table describes the DFB inputs:

Input	Type	Range	Default Value	Description
Mms_in1	INT	–	0	Must be linked to the first word of the MMS Profibus slave input cyclic data
Mms_in2	INT	–	0	Must be linked to the second word of the MMS Profibus slave input cyclic data
Mms_in5	INT	–	0	Must be linked to the fifth word of the MMS Profibus slave input cyclic data
Run_rev	EBOOL	0...1	0	Motor run reverse command
Off_cmd	EBOOL	0...1	0	Stop command
Run_fwd	EBOOL	0...1	0	Motor run forward command
Rstflt	EBOOL	0...1	0	Fault reset command
Em_strt	EBOOL	0...1	0	Emergency start (reset thermal memory)
Autotest	EBOOL	0...1	0	Self test command
Automode_cmd	EBOOL	0...1	0	Auto mode command
Lo_speed	EBOOL	0...1	0	Motor low speed command

Output Characteristics

The following table describes the DFB outputs and their availability according to the programming platform:

Output	Type	Range	Default Value	Description
Mms_out1	INT	–	0	Must be linked to the first word of the Profibus slave output cyclic data
Rev_st	EBOOL	0...1	0	Run reverse
Off_st	EBOOL	0...1	0	System Off
Fwd_st	EBOOL	0...1	0	Run forward
Th_ov_st	EBOOL	0...1	0	Thermal overload
Automode_st	EBOOL	0...1	0	Auto mode
Fault	EBOOL	0...1	0	System fault
Alarm	EBOOL	0...1	0	System warning
Ready	EBOOL	0...1	0	System ready
Starting	EBOOL	0...1	0	Motor starting
Running	EBOOL	0...1	0	Motor running (with detection of a current, if greater than 10% FLC)
Tripped	EBOOL	0...1	0	System tripped
Auto_rst	EBOOL	0...1	0	Auto-reset active
Pwr_rqst	EBOOL	0...1	0	Fault power cycle requested
Rst_time	EBOOL	0...1	0	Motor restart time undefined
Rpd_cycl	EBOOL	0...1	0	Rapid cycle lockout
Load_shd	EBOOL	0...1	0	Voltage load shedding
Hi_speed	EBOOL	0...1	0	Motor high speed
Hmi_loss	EBOOL	0...1	0	HMI port communication loss
Net_loss	EBOOL	0...1	0	Network port communication loss
Motor_tr	EBOOL	0...1	0	Motor transition lockout
Avg_curr	INT	0...2000	0	Average motor current (x 0.1 % FLA)

Chapter 6

Cyclic Control/Command DFB

Introduction

This chapter describes the TeSys U and TeSys T cyclic control/command DFBs.

What Is in This Chapter?

This chapter contains the following topics:

Topic	Page
Ctrl_cmd_u: TeSys U Cyclic Control/Command	90
Ctrl_cmd_t: TeSys T Cyclic Control/Command	92

Ctrl_cmd_u: TeSys U Cyclic Control/Command

Presentation

The Ctrl_cmd_u DFB is dedicated to the control and command of a single TeSys U starter-controller through cyclic data exchanges on Modbus/TCP (IO scanning), CANopen, and Advantys STB networks.

For more information, see:

- *TeSys U LULC032-033 Modbus Communication Module User Manual*
- *TeSys U LULC08 CANopen Communication Module User Manual*
- *TeSys U LULC15 Advantys STB Communication Module User Manual*

Characteristics

Characteristic	Value
Name	Ctrl_cmd_u
Version	1.00 and 1.10
Input	7
Output	11
Input/Output	0
Public Variable	0

NOTE:

- Version 1.10 is compatible with Quantum, Premium, and M340 PLCs.
- Version 1.00 is compatible only with Premium and M340 PLCs.

Graphical Representation

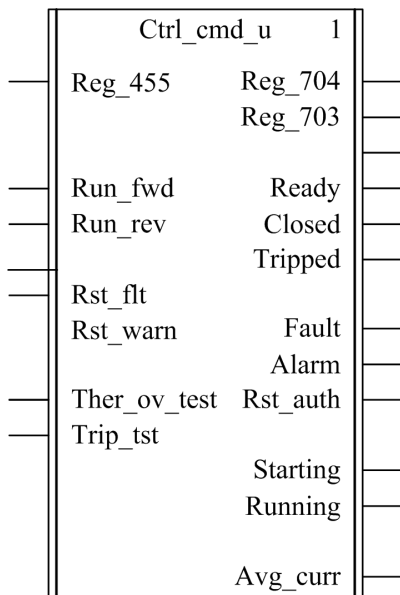

TeSys U Compliance

The Ctrl_cmd_u DFB is compliant with the following TeSys U sub-assemblies:

Power base	<ul style="list-style-type: none"> ● LUB** non-reversing power base ● LU2B** reversing power base
Control unit	<ul style="list-style-type: none"> ● LUCA standard control unit ● LUCB and LUCD advanced control units ● LUCC advanced control unit (up to 32 A/15 kW or 20 hp) ● LUCL magnetic control unit ● LUCM multifunction control unit (up to 32 A/15 kW or 20 hp)
Communication module	<ul style="list-style-type: none"> ● LULC08 CANopen communication module ● LULC15 Advantys STB communication module ● LULC033 Modbus communication module with an Ethernet gateway

Input Characteristics

The following table describes the DFB inputs and their availability according to the control unit:

Input	Type	Range	Default Value	Description	LUCA LUCL	LUCB LUCC LUCD	LUCM
Reg_455	INT	0...65535	0	To link to register 455 of cyclic data inputs	√	√	√
Run_fwd	EBOOL	0...1	0	Motor run forward command	√	√	√
Run_rev	EBOOL	0...1	0	Motor run reverse command	√	√	√
Rst_ft	EBOOL	0...1	0	Reset device (if device 451 = 102 or 104, fault acknowledgment causes a return to communication module factory settings)	√	√	√
Rst_warn	EBOOL	0...1	0	Reset warning (for example, communication loss)	√	√	√
Ther_ov	EBOOL	0...1	0	Automatic thermal overload fault test	–	–	√
Trip_tst	EBOOL	0...1	0	Overcurrent trip test via communication bus	–	–	√

Output Characteristics

The following table describes the DFB outputs and their availability according to the control unit:

Output	Type	Range	Default Value	Description	LUCA LUCL	LUCB LUCC LUCD	LUCM
Reg_704	INT	0...65535	0	To link to register 704 of cyclic data outputs	√	√	√
Reg_703	INT	0...65535	0	To link to register 703 of cyclic data outputs	√	√	√
Ready	EBOOL	0...1	0	System ready: the rotary handle is turned to On position and there is no fault.	√	√	√
Closed	EBOOL	0...1	0	Pole status: closed	√	√	√
Tripped	EBOOL	0...1	0	System tripped: the rotary handle is turned to Trip position.	√	√	√
Fault	EBOOL	0...1	0	All faults	√	√	√
Alarm	EBOOL	0...1	0	All warnings	√	√	√
Rst_auth	EBOOL	0...1	0	Fault reset authorized	–	√	√
Starting	EBOOL	0...1	0	Start in progress: 0 = descending current is lower than 150% FLA 1 = ascending current is greater than 10% FLA	–	√	√
Running	EBOOL	0...1	0	Motor running with detection of current, if greater than 10% FLA	–	√	√
Avg_curr	INT	0...200	0	Average motor current (x 1% FLA)	–	√	√

Ctrl_cmd_t: TeSys T Cyclic Control/Command

Presentation

The Ctrl_cmd_t DFB is dedicated to the control and command of a single TeSys T LTM R••C•• CANopen or a TeSys T LTMR••E•• Modbus/TCP controller through cyclic data exchanges on Modbus/TCP (IO scanning) and CANopen networks.

For more information, see:

- *TeSys T LTMR Ethernet Communication Guide*
- *TeSys T LTMR CANopen Communication Guide*

Characteristics

Characteristic	Value
Name	Ctrl_cmd_t
Version	1.00 and 1.10
Input	7
Output	21
Input/Output	0
Public Variable	0

NOTE:

- Version 1.10 is compatible with Quantum, Premium, and M340 PLCs.
- Version 1.0 is compatible only with Premium and M340 PLCs.

Graphical Representation

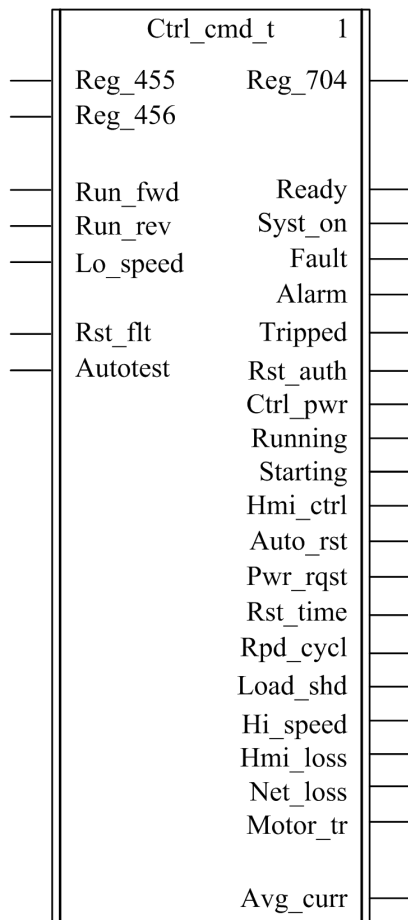

TeSys T Compliance

The Ctrl_cmd_t DFB is compliant with the TeSys T LTM R•C•• CANopen and with the TeSys T LTM R•E•• Modbus/TCP controller versions, with or without the LTM E expansion module.

Input Characteristics

The following table describes the DFB inputs:

Input	Type	Range	Default Value	Description
Reg_455	INT	0...65535	0	To link to register 455 of cyclic data inputs
Reg_456	INT	0...65535	0	To link to register 456 of cyclic data inputs
Run_fwd	EBOOL	0...1	0	Motor run forward command
Run_rev	EBOOL	0...1	0	Motor run reverse command
Lo_speed	EBOOL	0...1	0	Motor low speed command
Rstflt	EBOOL	0...1	0	Fault reset command
Autotest	EBOOL	0...1	0	Self test command

Output Characteristics

The following table describes the DFB outputs:

Output	Type	Range	Default Value	Description
Reg_704	INT	0...65535	0	To link to register 704 of cyclic data outputs
Ready	EBOOL	0...1	0	System ready
Syst_on	EBOOL	0...1	0	System On
Fault	EBOOL	0...1	0	System fault
Alarm	EBOOL	0...1	0	System warning
Tripped	EBOOL	0...1	0	System tripped
Rst_auth	EBOOL	0...1	0	Fault reset authorized
Ctrl_pwr	EBOOL	0...1	0	Controller power
Running	EBOOL	0...1	0	Motor running (with detection of a current, if greater than 10% FLC)
Hmi_ctrl	EBOOL	0...1	0	Control through HMI
Starting	EBOOL	0...1	0	Motor starting (start in progress) 0 = descending current is less than 150% FLC 1 = ascending current is greater than 10% FLC
Auto_rst	EBOOL	0...1	0	Auto-reset active
Pwr_rqst	EBOOL	0...1	0	Power cycle requested
Rst_time	EBOOL	0...1	0	Motor restart time undefined
Rpd_cycl	EBOOL	0...1	0	Rapid cycle lockout
Load_shd	EBOOL	0...1	0	Load shedding
Hi_speed	EBOOL	0...1	0	Motor speed 0 = FLC1 setting is used 1 = FLC2 setting is used
Hmi_loss	EBOOL	0...1	0	HMI port communication loss
Net_loss	EBOOL	0...1	0	Network port communication loss
Motor_tr	EBOOL	0...1	0	Motor transition lockout
Avg_curr	INT	0...200	0	Average motor current (x 1% FLA)

Chapter 7

PKW Exchanges DFB

Introduction

This chapter describes the TeSys U and TeSys T DFBs for PKW exchanges.

What Is in This Chapter?

This chapter contains the following topics:

Topic	Page
Special_pkw_u: TeSys U DFB for PKW Exchanges	96
Special_pkw_t: TeSys T DFB for PKW Exchanges	102
Custom_pkw: Custom Read DFB for PKW Exchanges	113

Special_pkw_u: TeSys U DFB for PKW Exchanges

Presentation

The Special_pkw_u DFB is dedicated to the reading of up to 16 predefined registers of a TeSys U starter-controller (up to 12 A/5.5 kW or 7 hp) with a LUCM multifunction control unit and one of the following communication modules that support PKW (Periodically Kept in Acyclic Words) exchanges:

- LULC07 (Profibus)
- LULC08 (CANopen)
- LULC15 (Advantys STB)

For more information, see:

- *LULC07 Profibus Communication Module User Manual*
- *LULC08 CANopen Communication Module User Manual*
- *LULC15 Advantys STB Communication Module User Manual*

Characteristics

Characteristic	Value
Name	Special_pkw_u
Version	1.00
Input	7
Output	3
Input/Output	2
Public Variable	2

Graphical Representation

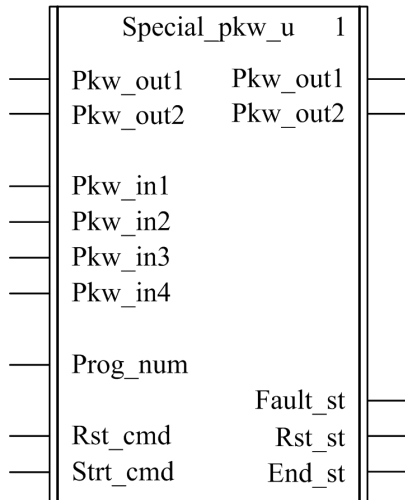

TeSys U Compliance

The Special_pkw_u DFB is compliant with the following TeSys U sub-assemblies:

Power base	<ul style="list-style-type: none"> ● LUB** non-reversing power base (up to 12 A/5.5 kW or 7 hp) ● LU2B** reversing power base (up to 12 A/5.5 kW or 7 hp)
Control unit	<ul style="list-style-type: none"> ● LUCM multifunction control unit
Communication module	<ul style="list-style-type: none"> ● LULC07 Profibus DP communication module ● LULC08 CANopen communication module ● LULC15 Advantys STB communication module
GSD file modules	Profibus: <ul style="list-style-type: none"> ● Sc Mu R MS PKW ● Sc Mu L MS PKW ● Sc Mu R MMS PKW ● Sc Mu L MMS PKW

Software Implementation

- Pkw_in1, Pkw_in2, Pkw_in3, and Pkw_in4 input words must be linked to the first 4 words of the PKW slave input cyclic data.
- Pkw_out1 and Pkw_out2 input/output words must be linked to the first 2 words of the PKW slave output cyclic data.
- The output data is only valid if the End_st output variable is set to 1 and if there is no fault detected (Fault_st = 0).
- When using TSXPBY100 Premium Profibus coupler it is mandatory to set %QWxy.0.242:X0 to 1 to guarantee the data consistency.

Input Characteristics

The following table describes the DFB inputs:

Input	Type	Range	Default Value	Description
Pkw_in1	INT	–	0	Must be linked to the first word of the PKW slave input cyclic data
Pkw_in2	INT	–	0	Must be linked to the second word of the PKW slave input cyclic data
Pkw_in3	INT	–	0	Must be linked to the third word of the PKW slave input cyclic data
Pkw_in4	INT	–	0	Must be linked to the fourth word of the PKW slave input cyclic data
Prog_num	INT	0...6	0	Program number See <i>Program Number</i> , page 97
Rst_cmd	EBOOL	0...1	0	Reset command
Strt_cmd	EBOOL	0...1	0	Start command

Output Characteristics

The following table describes the DFB outputs:

Output	Type	Range	Default Value	Description
Fault_st	EBOOL	0...1	0	Fault detected
Rst_st	EBOOL	0...1	0	Reset state
End_st	EBOOL	0...1	0	End state

Input/Output Characteristics

The following table describes the DFB input/outputs:

Input/Output	Type	Range	Default Value	Description
Pkw_out1	INT	–	0	Must be linked to the first word of the PKW slave output cyclic data
Pkw_out2	INT	–	0	Must be linked to the second word of the PKW slave output cyclic data

Program Number

The Prog_num input variable enables the user to define the public variables data depending on the application type. Each program uses variables related to one application (diagnostic, maintenance, measurement,...). The following table describes the programs of the DFB:

Program Number	Description
0	Bypass: no action
1	Diagnostic: faults monitoring variables, warnings monitoring variables, and communication monitoring variables
2	Maintenance: global statistics variables
3	Measurements: measurements monitoring variables
4	Statistics: last trip statistics and trip N–1 statistics
5	Statistics: N–2 and N–3 trip statistics
6	Statistics: N–4 trip statistics

Public Variables Characteristics

The following table describes the DFB public variables:

Public Variable	Type	Range	Default Value	Description
Sq_princ	INT	0...7	0	Reserved for support
Out_data[0]...[15]	ARRAY[0...15] of INT	0...65535	0	The output data depends on the program number

Out_data[0]...[15] Public Variable (Program 1)

The following table describes the Out_data[0]...[15] public variable in the case of the diagnostic program (program number 1):

Public Variable	Type	Register	Bit	Description
Out_data[0]	INT	452	0	Short-circuit fault
			1	Magnetic fault
			2	Ground fault
			3	Thermal fault
			4	Long start fault
			5	Jam fault
			6	Phase imbalance fault
			7	Underload fault
			8	Shunt trip fault
			9	Test trip fault
			10	Communication loss fault on LUCM Modbus port
			11	Control unit internal fault
			12	Module identification or internal communication fault
			13	Module internal fault
			14	Module trip fault
15	Module drop-out fault			
Out_data[1]	INT	461	0...1	Not significant
			2	Ground fault warning
			3	Thermal warning
			4	Long start warning
			5	Jam warning
			6	Phase imbalance warning
			7	Under-current warning
			8...9	Not significant
			10	Communication loss fault on LUCM Modbus port
			11	Internal temperature warning
			12	Module identification or internal communication warning
			13...14	Not significant
			15	Module warning
Out_data[2]	INT	457	0	Button position On (0 = Off)
			1	Button position Trip (0 = Not tripped)
			2	Contactactor state On
			3	24 Vdc power supply present on outputs
			4...15	Not significant
Out_data[3]	INT	450	-	Time to automatic reset on a thermal fault (s)
Out_data[4] ...Out_data[15]	-	-	-	Not significant

Out_data[0]...[15] Public Variable (Program 2)

The following table describes the Out_data[0]...[15] public variable in the case of the maintenance program (program number 2):

Public Variable	Type	Register	Description
Out_data[0]	INT	100	Short-circuit faults count
Out_data[1]	INT	101	Magnetic faults count
Out_data[2]	INT	102	Ground faults count
Out_data[3]	INT	103	Thermal faults count
Out_data[4]	INT	104	Long start faults count
Out_data[5]	INT	105	Jam faults count
Out_data[6]	INT	106	Phase imbalance faults count
Out_data[7]	INT	108	Shunt trip faults count
Out_data[8]	INT	115	Auto-resets count
Out_data[9]	INT	116	Thermal warnings count
Out_data[10]	INT	117	Starts count (LSB)
Out_data[11]	INT	118	Starts count (MSB)
Out_data[12]	INT	119	Operating time (LSB)
Out_data[13]	INT	120	Operating time (MSB)
Out_data[14]	INT	121	Maximum internal temperature (°C)
Out_data[15]	–	–	Not significant

Out_data[0]...[15] Public Variable (Program 3)

The following table describes the Out_data[0]...[15] public variable in the case of the measurements program (program number 3):

Public Variable	Type	Register	Description
Out_data[0]	–	–	Not significant
Out_data[1]	INT	465	Thermal capacity level (%)
Out_data[2]	INT	466	Average motor current (x 0.1 % FLA)
Out_data[3]	INT	467	L1 current (% FLA)
Out_data[4]	INT	468	L2 current (% FLA)
Out_data[5]	INT	469	L3 current (% FLA)
Out_data[6]	INT	470	Ground current (% FLA min)
Out_data[7]	INT	471	Current imbalance coefficient
Out_data[8]	INT	472	Control unit internal temperature (°C)
Out_data[9] ...Out_data[13]	–	–	Not significant
Out_data[14]	INT	79	Control unit sensor maximum current (x 0.1 A): <ul style="list-style-type: none"> ● 6 = adjustment range 0.15 to 0.6 A ● 14 = adjustment range 0.35 to 1.4 A ● 50 = adjustment range 1.25 to 5 A ● 120 = adjustment range 3 to 12 A ● 180 = adjustment range 4.5 to 18 A ● 320 = adjustment range 8 to 32 A
Out_data[15]	INT	652	Full load amps setting (% FLA max): <ul style="list-style-type: none"> ● minimum = 25 (default value) ● maximum = 100

Out_data[0]...[15] Public Variable (Program 4)

The following table describes the Out_data[0]...[15] public variable in the case of the statistics program (program number 4):

Public Variable	Type	Register	Description
Out_data[0]	INT	150	Last trip fault number
Out_data[1]	INT	152	Last trip thermal capacity level (% trip level)
Out_data[2]	INT	153	Last trip average current (% FLA)
Out_data[3]	INT	154	Last trip L1 current (% FLA)
Out_data[4]	INT	155	Last trip L2 current (% FLA)
Out_data[5]	INT	156	Last trip L3 current (% FLA)
Out_data[6]	INT	157	Last trip ground current (% FLA min)
Out_data[7]	INT	180	N-1 trip fault number
Out_data[8]	INT	182	N-1 trip thermal capacity level (% trip level)
Out_data[9]	INT	183	N-1 trip average current (% FLA)
Out_data[10]	INT	184	N-1 trip L1 current (% FLA)
Out_data[11]	INT	185	N-1 trip L2 current (%FLA)
Out_data[12]	INT	186	N-1 trip L3 current (% FLA)
Out_data[13]	INT	187	N-1 trip ground current (% FLA min)
Out_data[14]	INT	79	Control unit sensor maximum current (x 0.1 A): <ul style="list-style-type: none"> ● 6 = adjustment range 0.15 to 0.6 A ● 14 = adjustment range 0.35 to 1.4 A ● 50 = adjustment range 1.25 to 5 A ● 120 = adjustment range 3 to 12 A ● 180 = adjustment range 4.5 to 18 A ● 320 = adjustment range 8 to 32 A
Out_data[15]	INT	652	Full load amps setting (% FLA max): <ul style="list-style-type: none"> ● minimum = 25 (default value) ● maximum = 100

Out_data[0]...[15] Public Variable (Program 5)

The following table describes the Out_data[0]...[15] public variable in the case of the statistics program (program number 5):

Public Variable	Type	Register	Description
Out_data[0]	INT	210	N-2 trip fault number
Out_data[1]	INT	212	N-2 trip thermal capacity level (% trip level)
Out_data[2]	INT	213	N-2 trip average current (% FLA)
Out_data[3]	INT	214	N-2 trip L1 current (% FLA)
Out_data[4]	INT	215	N-2 trip L2 current (% FLA)
Out_data[5]	INT	216	N-2 trip L3 current (% FLA)
Out_data[6]	INT	217	N-2 trip ground current (% FLA min)
Out_data[7]	INT	240	N-3 trip fault number
Out_data[8]	INT	242	N-3 trip thermal capacity level (% trip level)
Out_data[9]	INT	243	N-3 trip average current (% FLA)
Out_data[10]	INT	244	N-3 trip L1 current (% FLA)
Out_data[11]	INT	245	N-3 trip L2 current (%FLA)
Out_data[12]	INT	246	N-3 trip L3 current (% FLA)
Out_data[13]	INT	247	N-3 trip ground current (% FLA min)
Out_data[14]	INT	79	Control unit sensor maximum current (x 0.1 A): <ul style="list-style-type: none"> ● 6 = adjustment range 0.15 to 0.6 A ● 14 = adjustment range 0.35 to 1.4 A ● 50 = adjustment range 1.25 to 5 A ● 120 = adjustment range 3 to 12 A ● 180 = adjustment range 4.5 to 18 A ● 320 = adjustment range 8 to 32 A

Public Variable	Type	Register	Description
Out_data[15]	INT	652	Full load amps setting (% FLA max): <ul style="list-style-type: none"> ● minimum = 25 (default value) ● maximum = 100

Out_data[0]...[15] Public Variable (Program 6)

The following table describes the Out_data[0]...[15] public variable in the case of the statistics program (program number 6):

Public Variable	Type	Register	Description
Out_data[0]	INT	270	N-4 trip fault number
Out_data[1]	INT	272	N-4 trip thermal capacity level (% trip level)
Out_data[2]	INT	273	N-4 trip average current (% FLA)
Out_data[3]	INT	274	N-4 trip L1 current (% FLA)
Out_data[4]	INT	275	N-4 trip L2 current (% FLA)
Out_data[5]	INT	276	N-4 trip L3 current (% FLA)
Out_data[6]	INT	277	N-4 trip ground current (% FLA min)
Out_data[7] ...Out_data[13]	–	–	Reserved
Out_data[14]	INT	79	Control unit sensor maximum current (x 0.1 A): <ul style="list-style-type: none"> ● 6 = adjustment range 0.15 to 0.6 A ● 14 = adjustment range 0.35 to 1.4 A ● 50 = adjustment range 1.25 to 5 A ● 120 = adjustment range 3 to 12 A ● 180 = adjustment range 4.5 to 18 A ● 320 = adjustment range 8 to 32 A
Out_data[15]	INT	652	Full load amps setting (% FLA max): <ul style="list-style-type: none"> ● minimum = 25 (default value) ● maximum = 100

Special_pkw_t: TeSys T DFB for PKW Exchanges

Presentation

The Special_pkw_t DFB is dedicated to the reading of up to 16 predefined registers of a single TeSys T LTM R••P•• Profibus controller through the Profibus (MS and MMS) network, and a TeSys T LTM R••C•• CANopen controller through the CANopen network, and supporting PKW (Periodically Kept in Acyclic Words) exchanges.

Characteristics

Characteristic	Value
Name	Special_pkw_t
Version	1.00
Input	7
Output	3
Input/Output	2
Public Variable	2

Graphical Representation

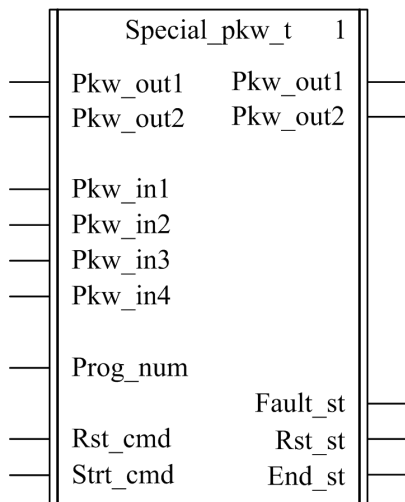

TeSys T Compliance

The Special_pkw_t DFB is compliant with all the TeSys T LTM R••P•• controller versions, with or without the LTM E expansion module.

Software Implementation

- Pkw_in1, Pkw_in2, Pkw_in3, and Pkw_in4 input words must be linked to the first 4 words of the PKW slave input cyclic data.
- Pkw_out1 and Pkw_out2 input/output words must be linked to the first 2 words of the PKW slave output cyclic data.
- The output data is only valid if the End_st output variable is set to 1 and if there is no fault detected (Fault_st = 0).
- When using TSXPBY100 Premium Profibus coupler it is mandatory to set %QWxy.0.242:X0 to 1 to guarantee the data consistency.

Input Characteristics

The following table describes the DFB inputs:

Input	Type	Range	Default Value	Description
Pkw_in1	INT	–	0	Must be linked to the first word of the PKW slave input cyclic data
Pkw_in2	INT	–	0	Must be linked to the second word of the PKW slave input cyclic data
Pkw_in3	INT	–	0	Must be linked to the third word of the PKW slave input cyclic data
Pkw_in4	INT	–	0	Must be linked to the fourth word of the PKW slave input cyclic data
Prog_num	INT	0..81	0	Program number See <i>Program Number, page 103</i>
Rst_cmd	EBOOL	0..1	0	Reset command
Strt_cmd	EBOOL	0..1	0	Start command

Output Characteristics

The following table describes the DFB outputs:

Output	Type	Range	Default Value	Description
Fault_st	EBOOL	0..1	0	Fault detected
Rst_st	EBOOL	0..1	0	Reset state
End_st	EBOOL	0..1	0	End state

Input/Output Characteristics

The following table describes the DFB input/outputs:

Input/Output	Type	Range	Default Value	Description
Pkw_out1	INT	–	0	Must be linked to the first word of the PKW slave output cyclic data
Pkw_out2	INT	–	0	Must be linked to the second word of the PKW slave output cyclic data

Program Number

The Prog_num input variable enables the user to define the public variables data depending on the application type. Each program holds variables related to one application (diagnostic, maintenance, measurement,...). The following table describes the programs of the DFB:

Program Number	Description
0	Bypass: no action
10	Diagnostic: faults monitoring variables, warnings monitoring variables, and communication monitoring variables
20	Maintenance: global statistics variables
30	Measurements 1
31	Measurements 2
32	Measurements 3
40	Statistics: last fault statistics (N–0)
41	Statistics: last fault statistics (with expansion module) (N–0)
50	Statistics: N–1 fault statistics
51	Statistics: N–1 fault statistics (with expansion module)
60	Statistics: N–2 fault statistics
61	Statistics: N–2 fault statistics (with expansion module)
70	Statistics: N–3 fault statistics
71	Statistics: N–3 fault statistics (with expansion module)
80	Statistics: N–4 fault statistics
81	Statistics: N–4 fault statistics (with expansion module)

Public Variables Characteristics

The following table describes the DFB public variables:

Public Variable	Type	Range	Default Value	Description
Sq_princ	INT	0...7	0	Reserved for support
Out_data[0]...[15]	ARRAY[0...15] of INT	0...65535	0	The output data depends on the program number

Out_data[0]...[15] Public Variable (Program 10)

The following table describes the Out_data[0]...[15] public variable in the case of the diagnostic program (program number 10):

Public Variable	Type	Register	Bit	Description
Out_data[0]	INT	452	0...1	Reserved
			2	Ground current fault
			3	Thermal overload fault
			4	Long start fault
			5	Jam fault
			6	Current phase imbalance fault
			7	Undercurrent fault
			8	Reserved
			9	Test fault
			10	HMI port fault
			11	Controller internal fault
			12	Internal port fault
			13	Not significant
			14	Network port config fault
			15	Network port fault
Out_data[1]	INT	453	0	External system fault
			1	Diagnostic fault
			2	Wiring fault
			3	Overcurrent fault
			4	Current phase loss fault
			5	Current phase reversal fault
			6	Motor temperature sensor fault (1)
			7	Voltage phase imbalance fault (1)
			8	Voltage phase loss fault (1)
			9	Voltage phase reversal fault (1)
			10	Undervoltage fault (1)
			11	Overvoltage fault (1)
			12	Underpower fault (1)
			13	Overpower fault (1)
			14	Under power factor fault (1)
15	Over power factor fault (1)			

Public Variable	Type	Register	Bit	Description
Out_data[2]	INT	461	0...1	Not significant
			2	Ground current warning
			3	Thermal overload warning
			4	Not significant
			5	Jam warning
			6	Current phase imbalance warning
			7	Undercurrent warning
			8...9	Not significant
			10	HMI port warning
			11	Controller internal temperature warning
			12...14	Not significant
			15	Network port warning
			Out_data[3]	INT
1	Diagnostic warning			
2	Reserved			
3	Overcurrent warning			
4	Current phase loss warning			
5	Current phase reversal warning			
6	Motor temperature sensor warning			
7	Voltage phase imbalance warning (1)			
8	Voltage phase loss warning (1)			
9	Not significant			
10	Undervoltage warning (1)			
11	Overvoltage warning (1)			
12	Underpower warning (1)			
13	Overpower warning (1)			
14	Under power factor warning (1)			
15	Over power factor warning (1)			
Out_data[4]	INT	457	0	Logic input 1
			1	Logic input 2
			2	Logic input 3
			3	Logic input 4
			4	Logic input 5
			5	Logic input 6
			6	Logic input 7
			7	Logic input 8 (1)
			8	Logic input 9 (1)
			9	Logic input 10 (1)
			10	Logic input 11 (1)
			11	Logic input 12 (1)
			12	Logic input 13 (1)
			13	Logic input 14 (1)
			14	Logic input 15 (1)
			15	Logic input 16 (1)

Public Variable	Type	Register	Bit	Description
Out_data[5]	INT	458	0	Logic output 1
			1	Logic output 2
			2	Logic output 3
			3	Logic output 4
			4	Logic output 5 (1)
			5	Logic output 6 (1)
			6	Logic output 7 (1)
			7	Logic output 8 (1)
			8...15	Reserved
Out_data[6]	INT	450	-	Minimum wait time (s)
Out_data[7] ...Out_data[15]	-	-	-	Reserved

(1) The variable is available for the LTM R controller and the LTM EV40 expansion module combination.

Out_data[0]...[15] Public Variable (Program 20)

The following table describes the Out_data[0]...[15] public variable in the case of the maintenance program (program number 20):

Public Variable	Type	Register	Description
Out_data[0]	INT	102	Ground current faults count
Out_data[1]	INT	103	Thermal overload faults count
Out_data[2]	INT	104	Long start faults count
Out_data[3]	INT	105	Jam faults count
Out_data[4]	INT	106	Current phase imbalance faults count
Out_data[5]	INT	107	Undercurrent faults count
Out_data[6]	-	-	Reserved
Out_data[7]	INT	114	Network port faults count
Out_data[8]	INT	115	Auto-resets count
Out_data[9]	INT	116	Thermal overload warnings count
Out_data[10]	INT	117	Motor starts count (LSB)
Out_data[11]	INT	118	Motor starts count (MSB)
Out_data[12]	INT	119	Operating time (s) (LSB)
Out_data[13]	INT	120	Operating time (MSB)
Out_data[14]	INT	121	Maximum controller internal temperature (°C)
Out_data[15]	-	-	Reserved

Out_data[0]...[15] Public Variable (Program 30)

The following table describes the Out_data[0]...[15] public variable in the case of the first measurements program (program number 30):

Public Variable	Type	Register	Description
Out_data[0]	-	-	Reserved
Out_data[1]	INT	465	Thermal capacity level (% trip level)
Out_data[2]	INT	466	Average current ratio (% FLC)
Out_data[3]	INT	467	L1 current ratio (% FLC)
Out_data[4]	INT	468	L2 current ratio (% FLC)
Out_data[5]	INT	469	L3 current ratio (% FLC)
Out_data[6]	INT	470	Ground current ratio (x 0.1 % FLC min)
Out_data[7]	INT	471	Current phase imbalance (%)
Out_data[8]	INT	472	Controller internal temperature (°C)
Out_data[9]	INT	474	Frequency (x 0.01 Hz)
Out_data[10]	INT	475	Motor temperature sensor (x 0.1 Ω)

Public Variable	Type	Register	Description
Out_data[11] ...Out_data[13]	–	–	Reserved
Out_data[14]	INT	96	Full load current (FLC) max (x 0.1 A)
Out_data[15]	INT	652	Motor full load current (FLC) ratio

Out_data[0]...[15] Public Variable (Program 31)

The following table describes the Out_data[0]...[15] public variable in the case of the second measurements program (program number 31):

Public Variable	Type	Register	Description
Out_data[0]	INT	500	Average current (x 0.01 A) MSB
Out_data[1]	INT	501	Average current (x 0.01 A) LSB
Out_data[2]	INT	502	L1 current (x 0.01 A) MSB
Out_data[3]	INT	503	L1 current (x0.01 A) LSB
Out_data[4]	INT	504	L2 current (x 0.01 A) MSB
Out_data[5]	INT	505	L2 current (x0.01 A) LSB
Out_data[6]	INT	506	L3 current (x 0.01 A) MSB
Out_data[7]	INT	507	L3 current (x0.01 A) LSB
Out_data[8]	INT	508	Ground current (x 0.001 A) MSB
Out_data[9]	INT	509	Ground current (x 0.001 A) LSB
Out_data[10]	INT	511	Time to trip (x 1 s)
Out_data[11]	INT	512	Motor last start current ratio (% FLC)
Out_data[12]	INT	513	Motor last start duration (s)
Out_data[13]	INT	514	Motor starts per hour count
Out_data[14] ...Out_data[15]	–	–	–

Out_data[0]...[15] Public Variable (Program 32)

The following table describes the Out_data[0]...[15] public variable in the case of the third measurements program (program number 32):

Public Variable	Type	Register	Description
Out_data[0]	INT	476	Average voltage (V)
Out_data[1]	INT	477	L3–L1 voltage (V)
Out_data[2]	INT	478	L1–L2 voltage (V)
Out_data[3]	INT	479	L2–L3 voltage (V)
Out_data[4]	INT	480	Voltage phase imbalance (%)
Out_data[5]	INT	481	Power factor (x 0.01)
Out_data[6]	INT	482	Active power (x 0.1 kW)
Out_data[7]	INT	483	Reactive power (x 0.1 kVAr)
Out_data[8] ...Out_data[15]	–	–	Reserved

Out_data[0]...[15] Public Variable (Program 40)

The following table describes the Out_data[0]...[15] public variable in the case of the last fault statistics program (program number 40):

Public Variable	Type	Register	Description
Out_data[0]	INT	150	Detected fault code N–0
Out_data[1]	INT	151	Motor full load current ratio N–0 (% FLC max)
Out_data[2]	INT	152	Thermal capacity level N–0 (% trip level)
Out_data[3]	INT	153	Average current ratio N–0 (% FLC)
Out_data[4]	INT	154	L1 current ratio N–0 (% FLC)
Out_data[5]	INT	155	L2 current ratio N–0 (% FLC)

Public Variable	Type	Register	Description
Out_data[6]	INT	156	L3 current ratio N-0 (% FLC)
Out_data[7]	INT	157	Ground current ratio N-0 (x 0.1 % FLC min)
Out_data[8]	INT	158	Full load current max N-0 (x 0.1 A)
Out_data[9]	INT	159	Current phase imbalance N-0 (%)
Out_data[10]	INT	160	Frequency N-0 (x 0.1 Hz)
Out_data[11]	INT	161	Motor temperature sensor N-0 (x 0.1 Ω)
Out_data[12]	WORD[4]	162	Date and time N-0
Out_data[13]		163	See <i>DT_DateTime</i> , page 111
Out_data[14]		164	
Out_data[15]		165	

Out_data[0]...[15] Public Variable (Program 41)

The following table describes the Out_data[0]...[15] public variable in the case of the last fault statistics with expansion module program (program number 41):

Public Variable	Type	Register	Description
Out_data[0]	INT	166	Average voltage N-0 (V)
Out_data[1]	INT	167	L3-L1 voltage N-0 (V)
Out_data[2]	INT	168	L1-L2 voltage N-0 (V)
Out_data[3]	INT	169	L2-L3 voltage N-0 (V)
Out_data[4]	INT	170	Voltage phase imbalance N-0 (%)
Out_data[5]	INT	171	Active power N-0 (kW)
Out_data[6]	INT	172	Power factor N-0 (x 0.01)
Out_data[7] ...Out_data[15]	-	-	Reserved

Out_data[0]...[15] Public Variable (Program 50)

The following table describes the Out_data[0]...[15] public variable in the case of the N-1 fault statistics program (program number 50):

Public Variable	Type	Register	Description
Out_data[0]	INT	180	Detected fault code N-1
Out_data[1]	INT	181	Motor full load current ratio N-1 (% FLC max)
Out_data[2]	INT	182	Thermal capacity level N-1 (% trip level)
Out_data[3]	INT	183	Average current ratio N-1 (% FLC)
Out_data[4]	INT	184	L1 current ratio N-1 (% FLC)
Out_data[5]	INT	185	L2 current ratio N-1 (% FLC)
Out_data[6]	INT	186	L3 current ratio N-1 (% FLC)
Out_data[7]	INT	187	Ground current ratio N-1 (x 0.1 % FLC min)
Out_data[8]	INT	188	Full load current max N-1 (x 0.1 A)
Out_data[9]	INT	189	Current phase imbalance N-1 (%)
Out_data[10]	INT	190	Frequency N-1 (x 0.1 Hz)
Out_data[11]	INT	191	Motor temperature sensor N-1 (x 0.1 Ω)
Out_data[12]	WORD[4]	192	Date and time N-1
Out_data[13]		193	See <i>DT_DateTime</i> , page 111
Out_data[14]		194	
Out_data[15]		195	

Out_data[0]...[15] Public Variable (Program 51)

The following table describes the Out_data[0]...[15] public variable in the case of the N-1 fault statistics with expansion module program (program number 51):

Public Variable	Type	Register	Description
Out_data[0]	INT	196	Average voltage N-1 (V)
Out_data[1]	INT	197	L3-L1 voltage N-1 (V)
Out_data[2]	INT	198	L1-L2 voltage N-1 (V)
Out_data[3]	INT	199	L2-L3 voltage N-1 (V)
Out_data[4]	INT	200	Voltage phase imbalance N-1 (%)
Out_data[5]	INT	201	Active power N-1 (kW)
Out_data[6]	INT	202	Power factor N-1 (x 0.01)
Out_data[7] ...Out_data[15]	-	-	Reserved

Out_data[0]...[15] Public Variable (Program 60)

The following table describes the Out_data[0]...[15] public variable in the case of the N-2 fault statistics program (program number 60):

Public Variable	Type	Register	Description
Out_data[0]	INT	210	Detected fault code N-2
Out_data[1]	INT	211	Motor full load current ratio N-2 (% FLC max)
Out_data[2]	INT	212	Thermal capacity level N-2 (% trip level)
Out_data[3]	INT	213	Average current ratio N-2 (% FLC)
Out_data[4]	INT	214	L1 current ratio N-2 (% FLC)
Out_data[5]	INT	215	L2 current ratio N-2 (% FLC)
Out_data[6]	INT	216	L3 current ratio N-2 (% FLC)
Out_data[7]	INT	217	Ground current ratio N-2 (x 0.1 % FLC min)
Out_data[8]	INT	218	Full load current max N-2 (x 0.1 A)
Out_data[9]	INT	219	Current phase imbalance N-2 (%)
Out_data[10]	INT	220	Frequency N-2 (x 0.1 Hz)
Out_data[11]	INT	221	Motor temperature sensor N-2 (x 0.1 Ω)
Out_data[12]	WORD[4]	222	Date and time N-2
Out_data[13]		223	See <i>DT_DateTime</i> , page 111
Out_data[14]		224	
Out_data[15]		225	

Out_data[0]...[15] Public Variable (Program 61)

The following table describes the Out_data[0]...[15] public variable in the case of the N-2 fault statistics with expansion module program (program number 61):

Public Variable	Type	Register	Description
Out_data[0]	INT	226	Average voltage N-2 (V)
Out_data[1]	INT	227	L3-L1 voltage N-2 (V)
Out_data[2]	INT	228	L1-L2 voltage N-2 (V)
Out_data[3]	INT	229	L2-L3 voltage N-2 (V)
Out_data[4]	INT	230	Voltage phase imbalance N-2 (%)
Out_data[5]	INT	231	Active power N-2 (kW)
Out_data[6]	INT	232	Power factor N-2 (x 0.01)
Out_data[7] ...Out_data[15]	-	-	Reserved

Out_data[0]...[15] Public Variable (Program 70)

The following table describes the Out_data[0]...[15] public variable in the case of the N-3 fault statistics program (program number 70):

Public Variable	Type	Register	Description
Out_data[0]	INT	240	Detected fault code N-3
Out_data[1]	INT	241	Motor full load current ratio N-3 (% FLC max)
Out_data[2]	INT	242	Thermal capacity level N-3 (% trip level)
Out_data[3]	INT	243	Average current ratio N-3 (% FLC)
Out_data[4]	INT	244	L1 current ratio N-3 (% FLC)
Out_data[5]	INT	245	L2 current ratio N-3 (% FLC)
Out_data[6]	INT	246	L3 current ratio N-3 (% FLC)
Out_data[7]	INT	247	Ground current ratio N-3 (x 0.1 % FLC min)
Out_data[8]	INT	248	Full load current max N-3 (x 0.1 A)
Out_data[9]	INT	249	Current phase imbalance N-3 (%)
Out_data[10]	INT	250	Frequency N-3 (x 0.1 Hz)
Out_data[11]	INT	251	Motor temperature sensor N-3 (x 0.1 Ω)
Out_data[12]	WORD[4]	252	Date and time N-3
Out_data[13]		253	See <i>DT_DateTime</i> , page 111
Out_data[14]		254	
Out_data[15]		255	

Out_data[0]...[15] Public Variable (Program 71)

The following table describes the Out_data[0]...[15] public variable in the case of the N-3 fault statistics with expansion module program (program number 71):

Public Variable	Type	Register	Description
Out_data[0]	INT	256	Average voltage N-3 (V)
Out_data[1]	INT	257	L3-L1 voltage N-3 (V)
Out_data[2]	INT	258	L1-L2 voltage N-3 (V)
Out_data[3]	INT	259	L2-L3 voltage N-3 (V)
Out_data[4]	INT	260	Voltage phase imbalance N-3 (%)
Out_data[5]	INT	261	Active power N-3 (kW)
Out_data[6]	INT	262	Power factor N-3 (x 0.01)
Out_data[7] ...Out_data[15]	-	-	Reserved

Out_data[0]...[15] Public Variable (Program 80)

The following table describes the Out_data[0]...[15] public variable in the case of the N–4 fault statistics program (program number 80):

Public Variable	Type	Register	Description
Out_data[0]	INT	270	Detected fault code N–4
Out_data[1]	INT	271	Motor full load current ratio N–4 (% FLC max)
Out_data[2]	INT	272	Thermal capacity level N–4 (% trip level)
Out_data[3]	INT	273	Average current ratio N–4 (% FLC)
Out_data[4]	INT	274	L1 current ratio N–4 (% FLC)
Out_data[5]	INT	275	L2 current ratio N–4 (% FLC)
Out_data[6]	INT	276	L3 current ratio N–4 (% FLC)
Out_data[7]	INT	277	Ground current ratio N–4 (x 0.1 % FLC min)
Out_data[8]	INT	278	Full load current max N–4 (x 0.1 A)
Out_data[9]	INT	279	Current phase imbalance N–4 (%)
Out_data[10]	INT	280	Frequency N–4 (x 0.1 Hz)
Out_data[11]	INT	281	Motor temperature sensor N–4 (x 0.1 Ω)
Out_data[12]	WORD[4]	282	Date and time N–4
Out_data[13]		283	See <i>DT_DateTime</i> , page 111
Out_data[14]		284	
Out_data[15]		285	

Out_data[0]...[15] Public Variable (Program 81)

The following table describes the Out_data[0]...[15] public variable in the case of the N–4 fault statistics with expansion module program (program number 81):

Public Variable	Type	Register	Description
Out_data[0]	INT	286	Average voltage N–4 (V)
Out_data[1]	INT	287	L3–L1 voltage N–4 (V)
Out_data[2]	INT	288	L1–L2 voltage N–4 (V)
Out_data[3]	INT	289	L2–L3 voltage N–4 (V)
Out_data[4]	INT	290	Voltage phase imbalance N–4 (%)
Out_data[5]	INT	291	Active power N–4 (kW)
Out_data[6]	INT	292	Power factor N–4 (x 0.01)
Out_data[7] ...Out_data[15]	–	–	Reserved

DT_DateTime

DT_DateTime is WORD[4] type and indicates date and time:

Register	Bits 15...12	Bits 11...8	Bits 7...4	Bits 3...0
Register N	s	s	0	0
Register N+1	H	H	m	m
Register N+2	M	M	D	D
Register N+3	Y	Y	Y	Y

Where:

- 0 = unused
- s = second
The format is 2 binary coded decimal (BCD) digits.
The value range is 00...59 in BCD.
- m = minute
The format is 2 binary coded decimal (BCD) digits.
The value range is 00...59 in BCD.
- H = hour
The format is 2 binary coded decimal (BCD) digits.

- The value range is 00...23 in BCD.
- D = day
 - The format is 2 binary coded decimal (BCD) digits.
 - The value range is (in BCD):
 - 01...31 for months 01, 03, 05, 07, 08, 10, 12,
 - 01...30 for months 04, 06, 09, 11,
 - 01...29 for month 02 in a leap year,
 - 01...28 for month 02 in a non-leap year.
- M = month
 - The format is 2 binary coded decimal (BCD) digits.
 - The value range is 01...12 in BCD.
- Y = year
 - The format is 4 binary coded decimal (BCD) digits.
 - The value range is 2006...2099 in BCD.

Data entry format and value range are:

Data entry format	DT#YYYY-MM-DD-HH:mm:ss	
Minimum value	DT#2006-01-01-00:00:00	January 1, 2006
Maximum value	DT#2099-12-31-23:59:59	December 31, 2099

NOTE: If the user enters values outside the defined range, the system will return an error.

Custom_pkw: Custom Read DFB for PKW Exchanges

Presentation

The Custom_pkw DFB is dedicated to the reading of up to 5 sets of registers of a single TeSys device supporting PKW (Periodically Kept in Acyclic Words) exchanges.

A set of registers is defined by the address of the first register to read and the length of the set (up to 16 registers per set).

The Custom_pkw DFB completes the Special_pkw_u and Special_pkw_t DFBs and enables the user to select the registers to read.

Characteristics

Characteristic	Value
Name	Custom_pkw
Version	1.00
Input	6
Output	3
Input/Output	2
Public Variable	7

Graphical Representation

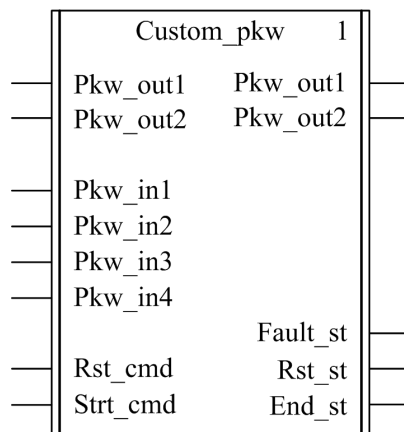

TeSys U and TeSys T Compliance

- TeSys U: The Custom_pkw DFB is compliant with the following TeSys U sub-assemblies:
 - LUB** non-reversing power base and LU2B** reversing power base (up to 12 A/5.5 kW or 7 hp)
 - LUCM multifunction control unit
 - PKW compliant communication module
- TeSys T: The Custom_pkw DFB is compliant with all the LTM R controller versions, with or without the LTM E expansion module.
- When using TSXPBY100 Premium Profibus coupler it is mandatory to set %QWxy.0.242:X0 to 1 to guarantee the data consistency.

Software Implementation

- Pkw_in1, Pkw_in2, Pkw_in3 and Pkw_in4 input words must be linked to the first 4 words of the PKW slave input cyclic data.
- Pkw_out1 and Pkw_out2 output words must be linked to the first word of the first 2 words of the PKW slave output cyclic data.
- The output data is only valid if the End_st output variable is set to 1 and if there is no fault detected (Fault_st = 0).
- The public variables enable the user to read up to 5 sets of registers of a maximum length of 16 registers for each set:

- The user defines the starting point of a set of registers with the In_reg public variable.
- The user defines the length of the set of registers with the corresponding In_len public variable.
- The registers content is then returned in the corresponding Out_dat public variable.

Example with TeSys T

The user wants to read 3 sets of TeSys T registers:

- Global statistics: registers 102...106 (5 registers)
- Measurements: registers 465...470 (6 registers)
- Controller identification: registers 64...74 (11 registers)

The following table describes the values of the corresponding In_reg and In_len public variables:

Public Variable	Value
In_reg[0]	102
In_reg[1]	465
In_reg[2]	64
In_len[0]	5
In_len[1]	6
In_len[2]	11

The following table describes the values of the corresponding Out_dat public variables:

Public Variable	Register	Description
Out_dat0	Out_dat0[0]	102 Ground current faults count
	Out_dat0[1]	103 Thermal overload faults count
	Out_dat0[2]	104 Long start faults count
	Out_dat0[3]	105 Jam faults count
	Out_dat0[4]	106 Current phase imbalance faults count
Out_dat1	Out_dat1[0]	465 Thermal capacity level (% trip level)
	Out_dat1[1]	466 Average current ratio (% FLC)
	Out_dat1[2]	467 L1 current ratio (% FLC)
	Out_dat1[3]	468 L2 current ratio (% FLC)
	Out_dat1[4]	469 L3 current ratio (% FLC)
	Out_dat1[5]	470 Ground current ratio (x 0.1 % FLC min)
Out_dat2	Out_dat2[0]	64 Controller commercial reference MSB = ASCII char 1, LSB = ASCII char 2
	Out_dat2[1]	65 Controller commercial reference MSB = ASCII char 3, LSB = ASCII char 4
	Out_dat2[2]	66 Controller commercial reference MSB = ASCII char 5, LSB = ASCII char 6
	Out_dat2[3]	67 Controller commercial reference MSB = ASCII char 7, LSB = ASCII char 8
	Out_dat2[4]	68 Controller commercial reference MSB = ASCII char 9, LSB = ASCII char 10
	Out_dat2[5]	69 Controller commercial reference MSB = ASCII char 11, LSB = ASCII char 12
	Out_dat2[6]	70 Controller serial number, register 1
	Out_dat2[7]	71 Controller serial number, register 2
	Out_dat2[8]	72 Controller serial number, register 3
	Out_dat2[9]	73 Controller serial number, register 4
	Out_dat2[10]	74 Controller serial number, register 5

Input Characteristics

The following table describes the DFB inputs :

Input	Type	Range	Default Value	Description
Pkw_in1	INT	–	0	Must be linked to the first word of the PKW slave input cyclic data
Pkw_in2	INT	–	0	Must be linked to the second word of the PKW slave input cyclic data
Pkw_in3	INT	–	0	Must be linked to the third word of the PKW slave input cyclic data
Pkw_in4	INT	–	0	Must be linked to the fourth word of the PKW slave input cyclic data
Rst_cmd	EBOOL	0...1	0	Reset command
Strt_cmd	EBOOL	0...1	0	Start command

Output Characteristics

The following table describes the DFB outputs :

Output	Type	Range	Default Value	Description
Fault_st	EBOOL	0...1	0	Fault detected
Rst_st	EBOOL	0...1	0	Reset state
End_st	EBOOL	0...1	0	End state

Input/Output Characteristics

The following table describes the DFB input/outputs :

Input/Output	Type	Range	Default Value	Description
Pkw_out1	INT	–	0	Must be linked to the first word of the PKW slave output cyclic data
Pkw_out2	INT	–	0	Must be linked to the second word of the PKW slave output cyclic data

Public Variables Characteristics

The following table describes the DFB public variables:

Public Variable	Type	Description
In_reg	ARRAY [0...4] of INT	Array of 5 words for the 5 index registers (In_reg[0]...In_reg[4])
In_len	ARRAY [0...4] of INT	Array of 5 words for the length of each set of registers (In_len[0]...In_len[4])
Out_dat[0]	ARRAY [0...15] of INT	Array of up to 16 words containing the In_len[0] words starting from In_reg[0]
Out_dat[1]	ARRAY [0...15] of INT	Array of up to 16 words containing the In_len[1] words starting from In_reg[1]
Out_dat[2]	ARRAY [0...15] of INT	Array of up to 16 words containing the In_len[2] words starting from In_reg[2]
Out_dat[3]	ARRAY [0...15] of INT	Array of up to 16 words containing the In_len[3] words starting from In_reg[3]
Out_dat[4]	ARRAY [0...15] of INT	Array of up to 16 words containing the In_len[4] words starting from In_reg[4]

Chapter 8

Treatment DFB

Introduction

This chapter describes the Scale and Timestamp treatment DFBs.

What Is in This Chapter?

This chapter contains the following topics:

Topic	Page
Scale: TeSys U DFB for Measurement Unit Conversion	118
Timestamp_*: TeSys U DFB for Data Time-Stamping	120

Scale: TeSys U DFB for Measurement Unit Conversion

Presentation

The Scale DFB is dedicated to the conversion of current measurement unit from relative value (% FLC) to Amps for a TeSys U starter-controller (up to 12 A/5.5 kW or 7 hp) with a multifunction control unit. It also enables the user to select another unit in the A...mA range.

The Scale DFB is particularly used with the Special_pkw_u or the Special_mdb_u DFBs.

Characteristics

Characteristic	Value
Name	Scale
Version	1.00
Input	1
Output	1
Input/Output	0
Public Variable	22

Graphical Representation

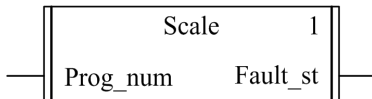

TeSys U Compliance

The Scale DFB is compliant with the following TeSys U sub-assemblies:

Power base	<ul style="list-style-type: none"> • LUB** non-reversing power base (up to 12 A/5.5 kW or 7 hp) • LU2B** reversing power base (up to 12 A/5.5 kW or 7 hp)
Control unit	<ul style="list-style-type: none"> • LUCM multifunction control unit

Software Implementation

See the Special_mdb_u DFB public variables description in *Public Variables Characteristics, page 41*.

The Scale DFB converts the measurements unit from % FLA to A and to any unit in the A...mA range:

- The Out_ri output variables return the current measurements in A.
- The Out_ii output variables return the current measurements in the unit chosen by the user in the A...mA range.

If a fault occurs:

- the Special_mdb_u DFB outputs are set to -1,
- the Scale DFB outputs are set to -1,
- the Scale DFB Fault_st output is set to 1.

Input Characteristics

The following table describes the DFB input:

Input	Type	Description
Prog_num	INT	The program number enables the user to select the measurement unit of the Scale DFB outputs (A...mA): <ul style="list-style-type: none"> • 0 = the unit is 1/1 A (coeff = 1) • 1 = the unit is 1/10 A (coeff = 10) • 2 = the unit is 1/100 A (coeff = 100) • 3 = the unit is 1/1000 A (coeff = 1000)

Output Characteristics

The following table describes the DFB output:

Output	Type	Description
Fault_st	EBOOL	Fault detected

Public Variables Characteristics

The following table describes the DFB public variables:

Public Variable	Type	Description
In_avg	INT	Average motor current (x 0.1 % FLA)
In_L1	INT	L1 current (% FLA)
In_L2	INT	L2 current (% FLA)
In_L3	INT	L3 current (% FLA)
In_gnd	INT	Ground current (% FLA min)
In_phimb	INT	Current imbalance coefficient
In_range	INT	Control unit sensor maximum current (x 0.1 A): <ul style="list-style-type: none"> 6 = adjustment range 0.15–0.6 A 14 = adjustment range 0.35–1.4 A 50 = adjustment range 1.25–5 A 120 = adjustment range 3–12 A 180 = adjustment range 4.5–18 A 320 = adjustment range 8–32 A
In_setup	INT	Full load amps setting (% FLA max): <ul style="list-style-type: none"> minimum = 25 (default value) maximum = 100
Out_ravg	REAL	Average motor current in A Scaling formula: $I_{Avg} \times (\text{adjustment range}) \times (\text{FLA setting}) / 100000$
Out_rl1	REAL	L1 current in A Scaling formula: $IL1 \times (\text{adjustment range}) \times (\text{FLA setting}) / 100000$
Out_rl2	REAL	L2 current in A Scaling formula: $IL2 \times (\text{adjustment range}) \times (\text{FLA setting}) / 100000$
Out_rl3	REAL	L3 current in A Scaling formula: $IL3 \times (\text{adjustment range}) \times (\text{FLA setting}) / 100000$
Out_rgnd	REAL	Ground current in A Scaling formula: $IGnd \times (\text{adjustment range} / 4) \times (\text{FLA setting}) / 100000$
Out_rimb	REAL	Current imbalance in A Scaling formula: $I_{imb} \times I_{Avg} / 100$
Out_rstp	REAL	Full load amps (FLA) in A Scaling formula: $(\text{adjustment range} \times \text{FLA setting}) / 1000$
Out_iavg	INT	Average motor current in unit defined in the Prog_num variable (1) Scaling formula: $Out_ravg \times \text{coeff} (1)$
Out_il1	INT	L1 current in unit defined in the Prog_num variable (1) Scaling formula: $Out_rl1 \times \text{coeff} (1)$
Out_il2	INT	L2 current in unit defined in the Prog_num variable (1) Scaling formula: $Out_rl2 \times \text{coeff} (1)$
Out_il3	INT	L3 current in unit defined in the Prog_num variable (1) Scaling formula: $Out_rl3 \times \text{coeff} (1)$
Out_ignd	INT	Ground current in unit defined in the Prog_num variable (1) Scaling formula: $Out_rgnd \times \text{coeff} (1)$
Out_iimb	INT	Current imbalance in unit defined in the Prog_num variable (1) Scaling formula: $Out_rimb \times \text{coeff} (1)$
Out_istp	INT	Full load amps (FLA) in unit defined in the Prog_num variable (1) Scaling formula: $Out_rstp \times \text{coeff} (1)$

(1) See the Prog_num input description in *Input Characteristics*, page 118. For example, if Prog_num = 3, then the unit is mA and the coeff = 1000.

Timestamp_*: TeSys U DFB for Data Time-Stamping

Presentation

The Timestamp_* DFBs are dedicated to the time-stamping of up to 8 input registers of a TeSys U starter-controller (up to 32 A/15 kW or 20 hp) with a LUCM multifunction control unit. It provides an output table of the 8 time-stamped registers and 4 date and time registers (see *DT_DateTime*, page 111).

- Timestamp is compatible with Premium and M340 PLCs.
- Timestamp_q is compatible with Quantum PLCs.

Characteristics

Characteristic	Value	
Name	Timestamp	Timestamp_q
Version	1.00	1.00
Input	3	3
Output	3	3
Input/Output	0	0
Public Variable	3	3

Graphical Representation

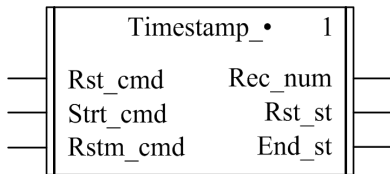

TeSys U Compliance

The Timestamp_* DFBs are compliant with all the TeSys U sub-assemblies.

Input Characteristics

The following table describes the DFB inputs:

Input	Type	Description
Rst_cmd	EBOOL	Reset time-stamping counter
Strt_cmd	EBOOL	Start time-stamping
Rstm_cmd	EBOOL	Reset time-stamping memory

Output Characteristics

The following table describes the DFB outputs:

Output	Type	Description
Rec_num	INT	Number of time-stamping operations since last reset
Rst_st	EBOOL	0 = Time-stamping is reset 1 = Time-stamping is not reset
End_st	EBOOL	0 = Time-stamping is not over 1 = Time-stamping is over

Public Variables Characteristics

The following table describes the DFB public variables:

Public Variable	Type	Description
In_data[0]...[7]	ARRAY[0...7] of INT	8 data registers to be time-stamped
Out_data[0]...[11]	ARRAY[0...11] of INT	<ul style="list-style-type: none"> ● Out_data[0]...Out_data[7]: 8 time-stamped data registers ● Out_data[8]: seconds (1) ● Out_data[9]: hours and minutes (1) ● Out_data[10]: month and day (1) ● Out_data[11]: year (1)
Sq_princ	INT	Reserved for support
(1) For more information regarding the date and time format, see <i>DT_DateTime</i> , page 111 .		



1672609EN-03

Schneider Electric Industries SAS

35, rue Joseph Monier
CS30323
F - 92506 Rueil Malmaison Cedex

www.se.com

As standards, specifications and designs change from time to time, please ask for confirmation of the information given in this publication.

01/2020