



# Control Panel Technical Guide

How to protect a machine  
from malfunctions due to  
electromagnetic disturbance



[schneider-electric.com](https://schneider-electric.com)

Life Is On

**Schneider**  
Electric



# Contents

Introduction p. 4-5



## Panel design in accordance with EMC rules

p. 6-11

Electromagnetic compatibility (EMC) of the electrical control panel

p. 7

Protection of low power signals

p. 8

Filtering

p. 8

Characteristics of an EMC-compliant panel

p. 9

Layout of equipment in a panel

p. 10

Reference regulations and standards

p. 11



## Assembly - panel wiring

p. 12-17

Panel assembly

p. 13

Installation of enclosures receiving polluted lines

p. 13

External routing of cables - entry into the panel

p. 14

Cable running in the panel

p. 16

Earth connection of shielding

p. 17

Earth connection of metal raceways

p. 17



## Guide for selection of "EMC" products

p. 18-21

Enclosures and panels with strengthened EMC

p. 19

Fans and accessories for strengthened EMC

p. 20

Accessories for strengthening EMC

p. 21



# Automatic control

## Their reliability is related

## The electrical control panel

## Severe industrial environment

**Industrial workshops are places in which there is often a high concentration of electromagnetic disturbance:**

- In the metallurgy industry, the electric power required generates very strong magnetic fields in the vicinity of electrolysis tanks and induction furnaces.
- Workshops manufacturing parts in PVC or rubber use high-frequency welding processes to perform assembly.

The propagation of strong magnetic fields and high-frequency waves is not easily controllable.

It creates local pollution in the midst of which the monitoring and control equipment must be able to operate.



**There are numerous ways of ensuring process electromagnetic compatibility (EMC: capability for operating in a disturbed environment).**

To obtain optimal performance, strict rules apply at all levels:

- building earthing system;
- communication cables, sensor cables;
- monitoring and control panels.

# Is: d to the level of disturbance. anel is affected.

## nts: when tight control is essential...

**Electromagnetic disturbances are present everywhere, up to the core of the control panels. Its effects are hard to predict.**

Electromagnetic disturbances are potential sources of malfunctions for all electronic equipment:

- Controllers and measuring devices, processing analogue signals;
- PLCs and communication interfaces, processing digital signals.

It will be hard to identify the presence of these disturbances because they may be transient and appear only in certain process conditions. Compliance with the design code is therefore recommended to avoid such problems.

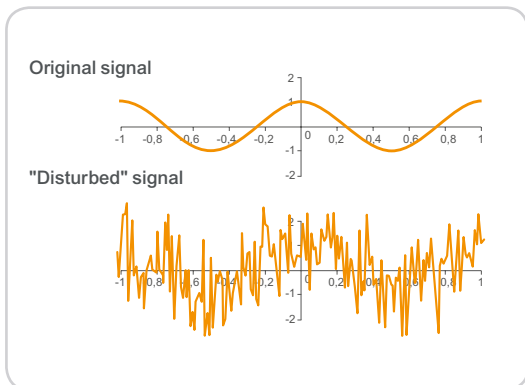

### Interference conducted by sensor cables

Interference of various frequencies is superimposed on the original signal. The signal thus becomes not very "understandable" for the equipment that receives it, and as a consequence its processing will be uncertain or impossible.

Configuration examples:

- runs along another highly disturbing cable (variable speed drive/motor link, for example);
- is not shielded;
- shielding is inappropriately linked (e.g. flow of "stray" currents caused by earthing of the two ends of shielding, especially in case of a TNC system).

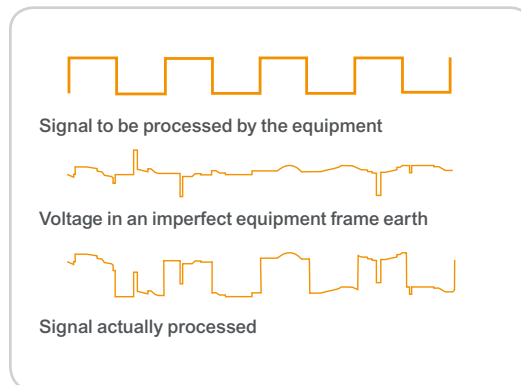

### Interference radiated by a device

A processing device is disturbed by a bundle of high-frequency waves: it stops suddenly, is reinitialized for no apparent reason or generates abnormal results. And yet the input signals are correct.

This type of situation can occur when the controller's earthing is incorrect: excessively thin wire, excessively resistive connection (existence of paint at the point of connection). A controller or electrical control panel cover containing too many "windows" can also be the cause of this.

**Worth knowing**

Some devices (converters, current choppers, etc.) incorporate oscillators whose voltage, frequency or signal shape makes them capable of emitting interference over variable distances, inside or outside the control panel. Covering of the equipment and its connection to the panel's frame earth are essential in order to limit radiation.



# Panel design in accordance with EMC rules

# Electromagnetic compatibility (EMC) of the electrical control panel

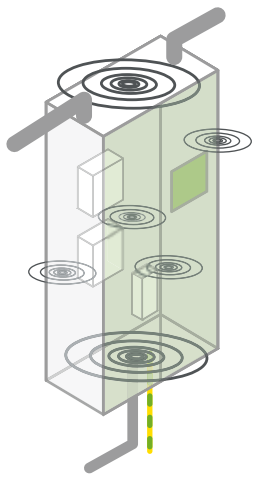

The electromagnetic compatibility (EMC) of a panel represents its capability for operating in a disturbed environment while limiting its own disturbing emissions.

Striving for overall efficiency will involve:

- reducing interference at the source, which may also be external to the panel;
- protection of the information exchanged with the process all along its route, including in the panel;
- panel protection against incoming radiated and conducted interference.

## 3 keys for optimized EMC:

- 1 > **Removal of interference** at source, via a well meshed earthing system.
- 2 > **Protection of low power connecting cables** by a continuous shielding.
- 3 > **Design and construction of the panel** in compliance with fundamental EMC principles.

## Role of the earthing system: safety and equipotential bonding

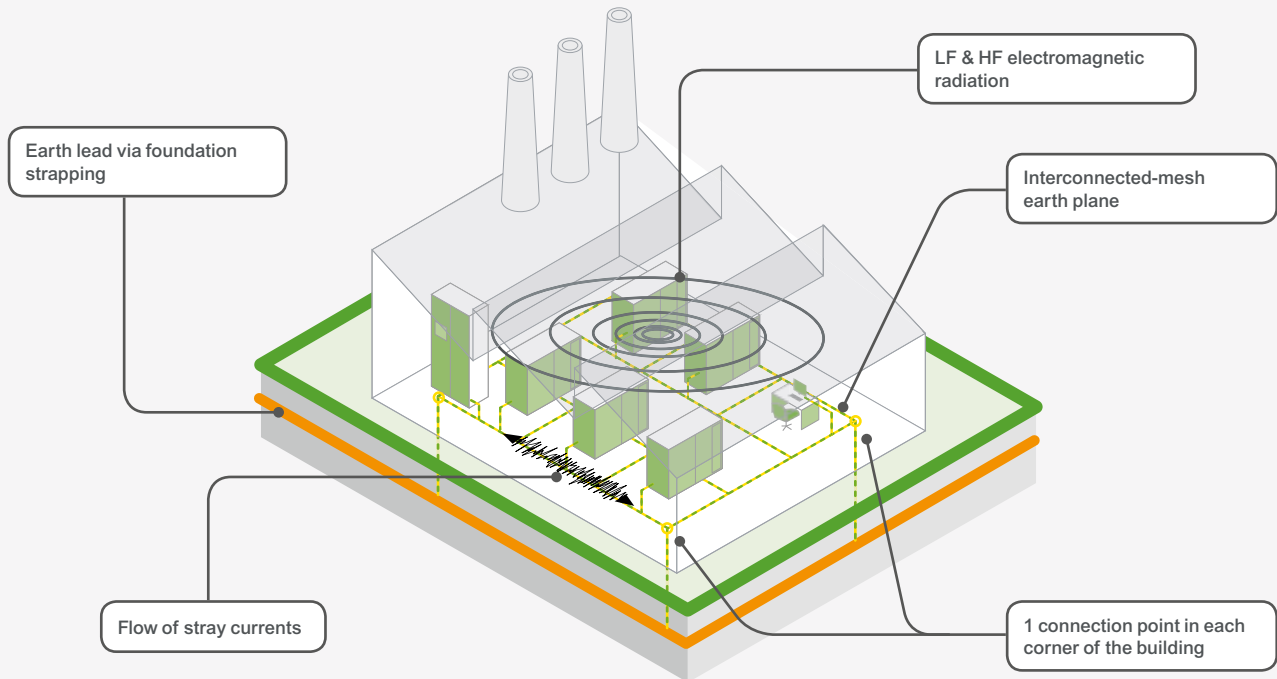

The regulations related to human safety require equipotential bonding of the exposed metallic conductive parts of all a building's equipment. Power and IT systems devices are therefore all connected to the building's single earthing system. Due to its interconnected meshes, this system also shields against pollution by high-frequency (HF) waves. The connection points distributed symmetrically around the building evenly balance the impedance of the earthing system.

However, even on installations in perfect condition, a flow of 50 Hz current can be observed on certain earth conductors (stray current). It can be as much as several amperes at a few millivolts if the conductor is sufficiently long. This current can interfere with low power analogue circuits (0-10 V sensor lines, etc.) if they are wired without taking precautions. Digital links are not greatly affected.

# Protection of low power signals

## Use shielded cables

Analogue sensor signals and data flows are sensitive to interference. Shielded cables are used to convey them. These cables are also used to execute variable speed drive/motor links generating less interference.

### The shielding consists of:

- a braid, which is an effective barrier for frequencies of up to a few megahertz;
- a metal strap, theoretically effective above such frequencies but which can easily be damaged during handling;
- a metal strap + braid for a mechanically strong broad spectrum protection.

Connection	Non-shielded	Shielded	
		End connected to frame earth:	
		1	2
Digital sensors	●	●	
0-10 V analogue output probes		●	
4-20 mA analogue output probes		●	
Communication bus			●
Variable speed drive/Motor link			●

## Connect the shielding to frame earth

This connection can remove interference to earth. The decision to connect one or both ends to earth means priority is given to protection against low or high frequencies (LF or HF):

- at a single end, 50 Hz stray currents cannot flow, moderate HF protection;
- at both ends, possible presence of 50 Hz current, but the barrier against higher frequencies is strengthened.

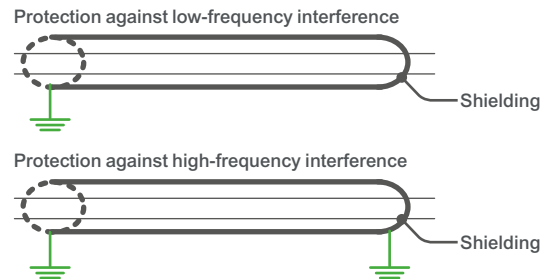

## Filtering

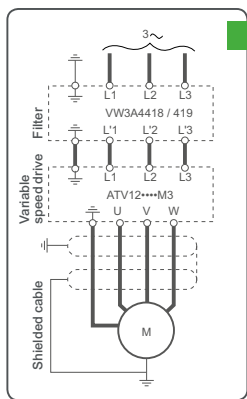

### Reducing the conduction of interference

Some devices generate disturbance on their upstream or downstream circuits: variable speed drives, frequency converters, switch mode power supplies, etc.

The most appropriate treatment is to arrange a filter on the disturbed line, as close as possible to the polluting device.

The appropriate filter characteristics are given by the manufacturers according to the voltage, the current in the line and the frequency of the disturbance to be reduced.

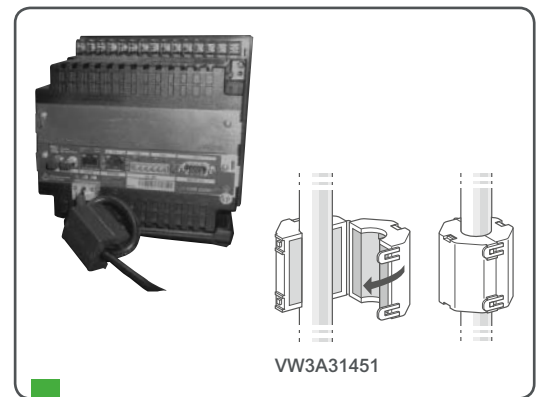

### Filters

They incorporate passive components (inductors, capacitors).

Their steel enclosure is fastened to the earthing plate, at the back of the panel. The contact surface must be free of paint/insulating material and be as large as possible.

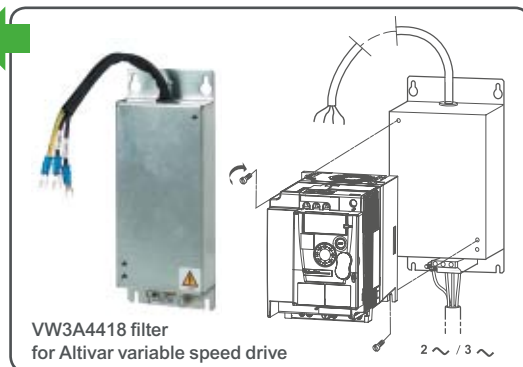

### Filter ferrite

When passed through by the polluted wire, the ferrite ring or tube represents an effective filter against high frequencies; it is often used to attenuate low-level cable disturbance.

Several windings of the wire in loops around the ferrite ring reinforce the attenuation (while preventing the ring from slipping if the wire is thin).



# Characteristics of an EMC-compliant panel

## Interference attenuation characteristics

If an electrical control panel without holes stops radio-frequency waves by "Faraday cage" effect, the magnetic radiation is attenuated by the sheets depending on the nature of the material. The greatest attenuation is obtained with Aluzinc sheets.

It is important to know the required attenuation for both effects (electric and magnetic fields) in order to suitably choose the appropriate panel.

### Comparison of AluZinc/steel attenuation

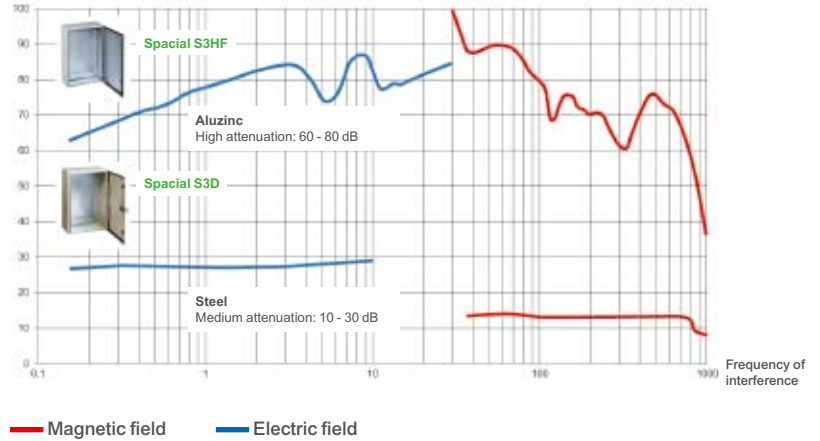

### Composition

Conductive panels, in steel, for example, offer good protection against electromagnetic radiation.

Interior linings and partitions in zinc-coated steel or non-lacquered aluminium strengthen this protection at various points.

### Electrical continuity

Given the assembled structure of the panel, electrical continuity between the various parts must be achieved so as to offer the lowest possible impedance. Contact points shall be free of paint or any other insulating coating to reduce their impedance / resistance.

### "Tightness" to interference

All apertures for cable routing, ventilation, indicator lamps, buttons and other components mounted on the front panel, and spaces around the door, could let in HF interference. They should be stopped up insofar as possible.

"EMC" seals and accessories are available for this purpose. For the largest apertures, provide for tubes and other metal conduits to form "waveguides" which will prevent high frequencies from entering.

# Layout of equipment in a panel

## 1 Importance of the layout

If high-power and low-power devices are juxtaposed without taking precautions and if cables of different kinds are routed in the same raceways, serious malfunctions are likely.

By allowing for the rules described below as of the design stage, one will avoid tedious troubleshooting, the ex-post installation of filters, or even reworking of the layout and wiring.

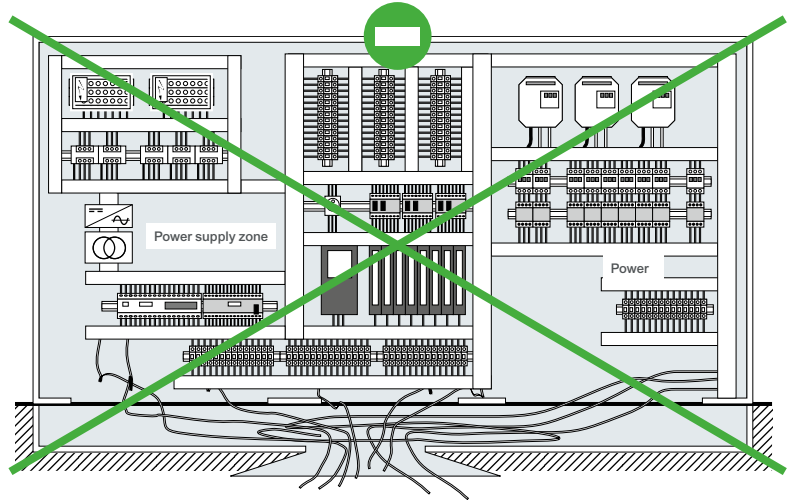

## 2 Separate

The dedication of panels by power class is the most efficient measure to obtain an excellent "EMC" result. Moreover, separate routing of disturbing and sensitive cables ensures minimum coupling.

A metal raceway ensures equipotential bonding of the panels and efficient conduction of LF and HF interference.

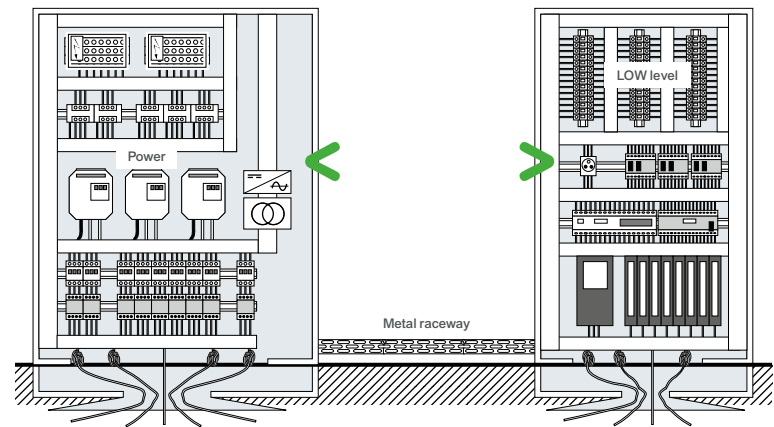

## 3 Partition

Partitioning of the panel into two zones:

- power, and
- low level,

is an alternative. A metal partition will be able to further improve EMC by confining each zone.

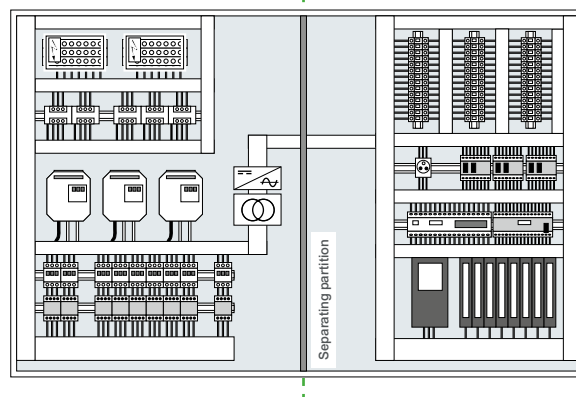

### For tricky situations

**In general, contactors should be kept away from electronic devices.**

it is recommended to provide wave-trap filters to contactors and relays.

A highly disturbing device (variable speed drive, frequency converter, etc.) will have less radiation in the panel if it is "encapsulated" in a small, electromagnetically sealed, unpainted metal enclosure. The enclosure should be carefully connected to the back plate (earth plane).

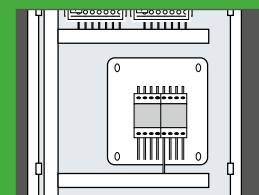

# Reference regulations and standards



## Apparatus: radiation and radiation resistance



### European directive

#### EMC 2014/30/UE

It relates to all electrical and electronic equipment placed on the market or put into service, excluding equipment covered by a specific directive (e.g. medical equipment).

This equipment must be designed so as not to generate electromagnetic disturbance that could disturb the operation of other equipment.

- It must also be capable of operating satisfactorily in the context of the planned application (environment, power supply mode, etc.).

The directive is based on IEC international standards:

- **for industrial environments,**  
IEC 61000-6-2 (immunity),  
IEC 61000-6-4 (emission);
- **for residential, commercial and light industrial environments,**  
IEC 61000-6-1 (immunity),  
IEC 61000-6-3 (emission).

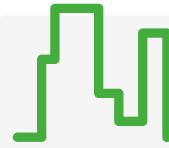

## Installations: main rules



### International

#### IEC 61000-5-2

Electromagnetic compatibility (EMC)  
Part 5: Installation and attenuation guide  
Section 2: Earthing and wiring

#### IEC 61000-5-6

Electromagnetic compatibility (EMC)  
Part 5: Installation and attenuation guide  
Section 6: mitigation of external electromagnetic influences

#### IEC 60364-4-44

Building electrical installations  
Part 4-44: Protection against voltage disturbance and electromagnetic disturbance



### European

#### EN 50174-2

Information technologies - Wiring installation  
Part 2: Planning and practices for installation inside buildings

#### EN 50310

Application of equipotential bonding and earthing in rooms with information technology equipment



### French

#### UTE C 15-900 Guide

Installation of power and communication networks in buildings

#### NF C90-480

Application of equipotential bonding and earthing in rooms with information technology equipment

#### NF C 90-480-2

Information technologies - Wiring installation.



## Assembly - panel wiring



# Assembly and panel wiring

## 1 > Panel assembly

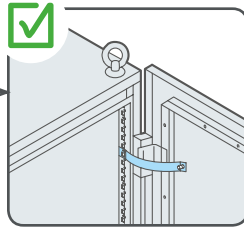
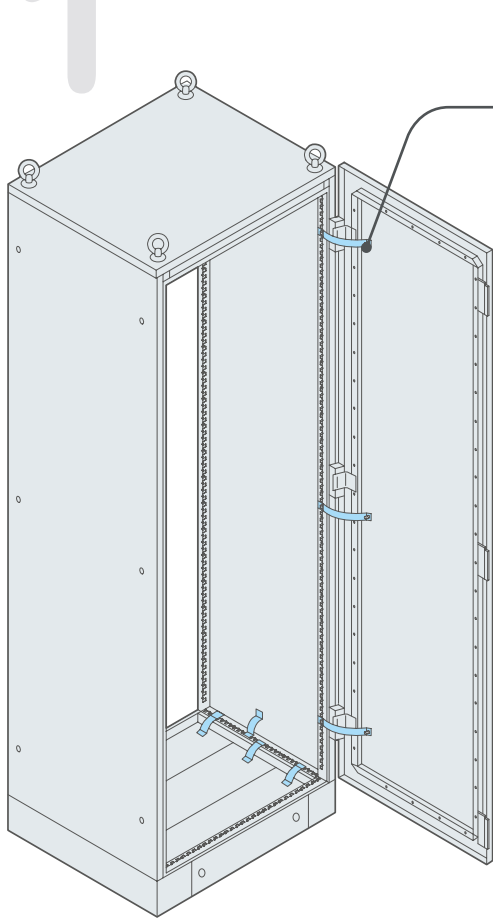

Bonding braid

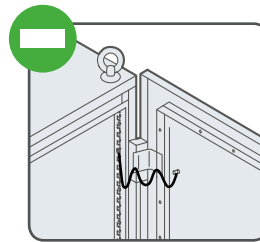

Earthing wire

### Optimization of frame earths

For satisfactory discharge of LF and HF disturbance, the panels are interconnected by braids, including the door. Braids must have a ratio Length/width <10 (maximum value) or <5 (recommended value).

The resistance of contact points is reduced by prior cleaning of any trace of paint or other insulating coating.

NB: A wire can in no case be substituted for a braid.

### Earth plane

An unpainted metal plate is placed at the back of the panel to form an earth plane to which will be connected the various braids, the incoming earth cable, cable shielding, etc.

### Openings

In an electromagnetic environment in conformity with EMC standards(\*), apertures in the panels to receive measuring instruments, displays and screens shall be reduced to what is strictly necessary to limit the entry of high-frequency flows.

(\* ) The maximum disturbance levels acceptable in Residential/Service Sector/Small Industry and Industrial environments are defined by the IEC 61000-6-x standard, series 1, 2, 3 and 4, and EC directives.

## 2 > Installation of enclosures receiving polluted lines

### Positioning of filters and power supplies

These components are installed in the panel. When it is presumed that their external connection will take place via a polluted cable, then the enclosures should be arranged so as to allow only a minimum cable length to enter. The radiation of HF disturbance will thus be reduced.

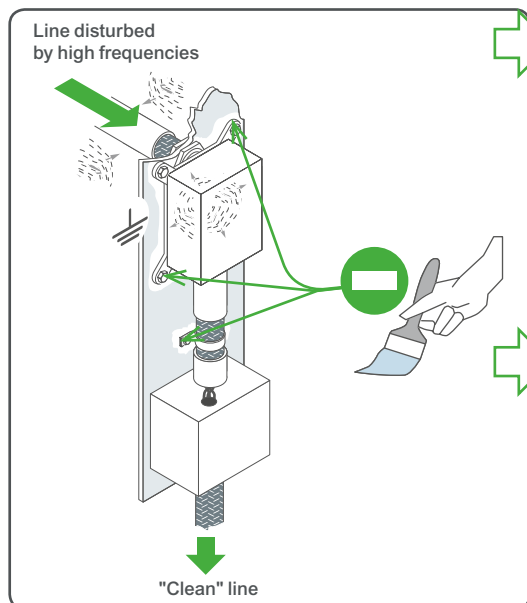
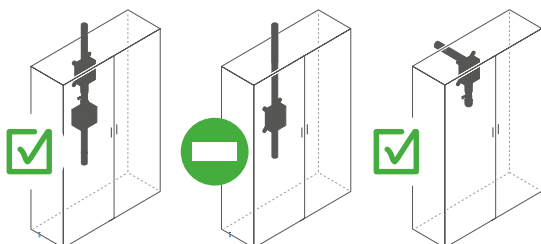

Shielded cables should preferably be used, with the shielding connected to the panel's earthing plate. If the length of the incoming cable exceeds 1 m, connect its shielding to the entry point and at the filter level.

The metallic enclosure shall be fastened to the earthing plate, and contact points should be free of paint and any other resistive or insulating material.

# Panel wiring

## 3 > External routing of cables - entry into the panel

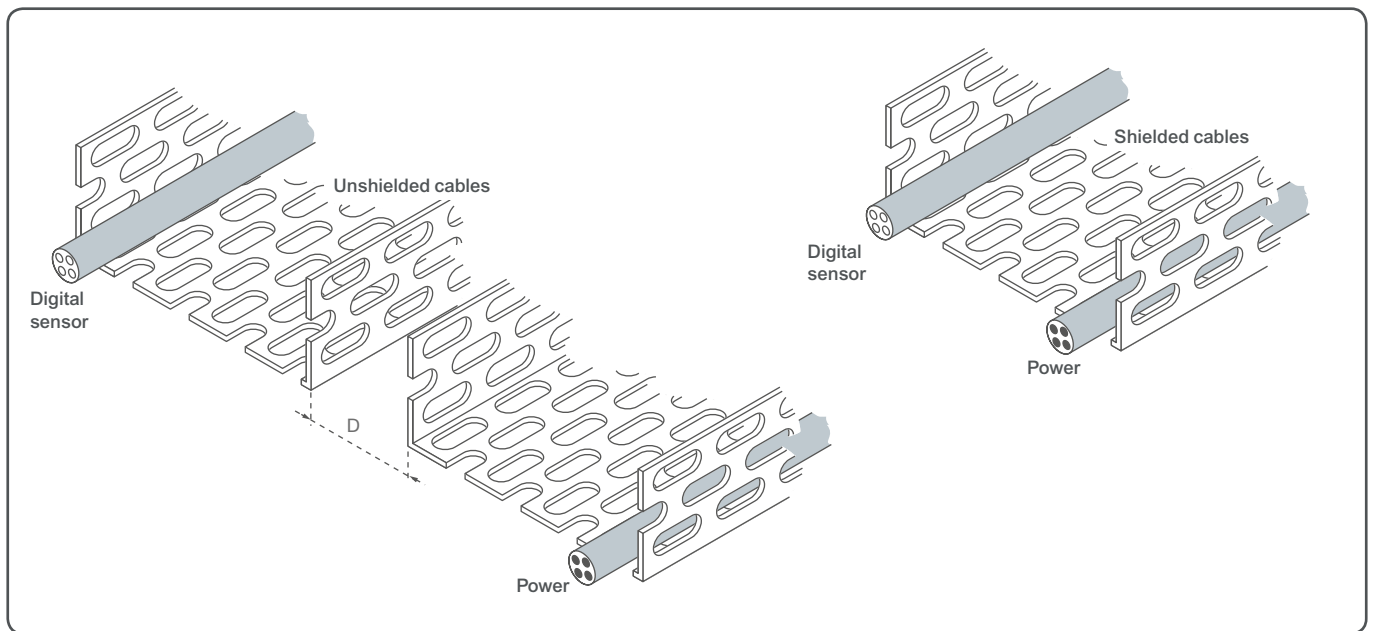

### 1 External routing in metal raceways

Keep high-power cables away from low-power cables:

- separate raceways if the cables are unshielded  $D \geq 5\text{ cm}$ ,
- single raceway possible if the low-power cables are shielded, but maximum spacing.

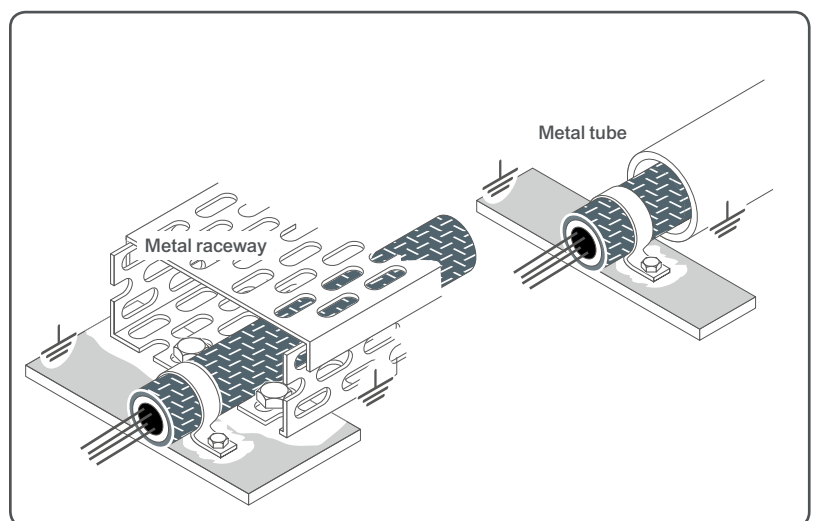

### 2 Increasing the efficiency of the shielding on highly disturbing cables

The radiation from a shielded variable speed drive/motor connecting cable will be further reduced if it runs in a closed metal raceway or, even better, in a metal conduit. The raceway and tube are connected to earth at either end.

# Panel wiring

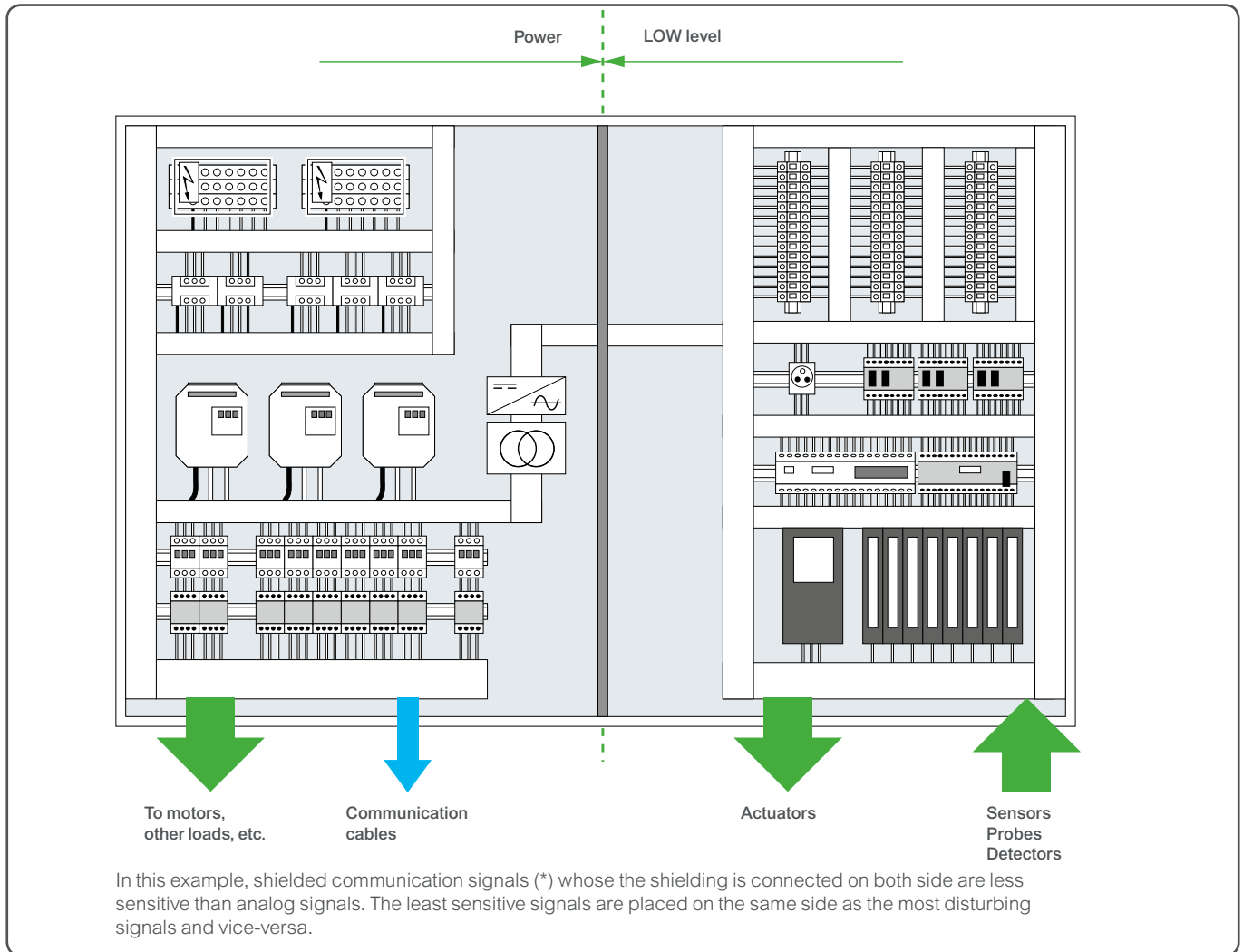

(\*) Classification of conveyed signals (standards IEC 61000-5-2 and IEC 60364-4-44).

Class	Disturber	Sensitive	Example of connected signals or connected devices
1 Sensitive		++	<ul style="list-style-type: none"> <li>Low-level circuits with analog output units, sensors, ...</li> <li>Instrument circuits (probe, sensors, ...)</li> </ul>
2 Not very sensitive		+	<ul style="list-style-type: none"> <li>Control command circuits with resistive load</li> <li>Digitalized low-level circuits (Bus, ...)</li> <li>Low-level circuits with on-off output unit (sensors, ...)</li> <li>Low-level direct power supply</li> </ul>
3 Not very disturber	+		<ul style="list-style-type: none"> <li>Control command circuits with inductive load (relay, contactors, coils, inverter, ...) with adapted protection</li> <li>Alternating power supply</li> <li>Main power supply connected to power devices</li> </ul>
4 Disturber	++		<ul style="list-style-type: none"> <li>Welding machines</li> <li>Power circuit</li> <li>Drive, switch mode power supplies, ...</li> </ul>

### 3 Organization of cable entries

Group the cables by type of current:

- high power: power supply, PEN conductors, etc., actuators;
- low power (< 100 mA): analogue communication.

Create specific entries in the panel, one for each type of current.

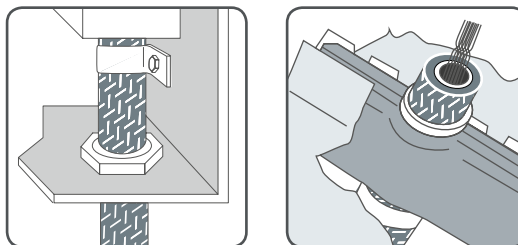

### 4 Shielded cable entries

The use of metal cable glands tightened to 360° ideally protects EMC. The cable shielding is connected to the panel's frame earth over its entire perimeter without being interrupted. It extends over the cable's entire internal route up to the terminal block, the filter or the variable speed drive where it is again connected to frame earth.

The earthing gaskets clamping the shielding at the point of entry are an alternative solution to cable glands.

# Panel wiring

## 4

### > Cable running in the panel



#### To be avoided

##### Capacitive effects

Two cables running alongside one another constitute the armatures of a capacitor. The high-frequency components present in one of them (transient surge, pulses, for example) pass into the other cable by going through the stray capacitance.

##### Inductive loops

An alternating current (50 Hz, harmonics), or pulse current (e.g. lightning) flowing in a panel and forming a loop creates an inductive winding. All the electrical equipment located in this loop will be passed through by a current identical to the original current. Its energy may be significant if the winding is formed by a power cable.

##### Local electromagnetic disturbance

The variable electromagnetic fields generated during switching of a contactor coil or at opening of the power contacts disturb the adjacent conductors by coupling effect. The effect is heightened if the disturbing and/or disturbed conductors form windings.

### Example: control panels

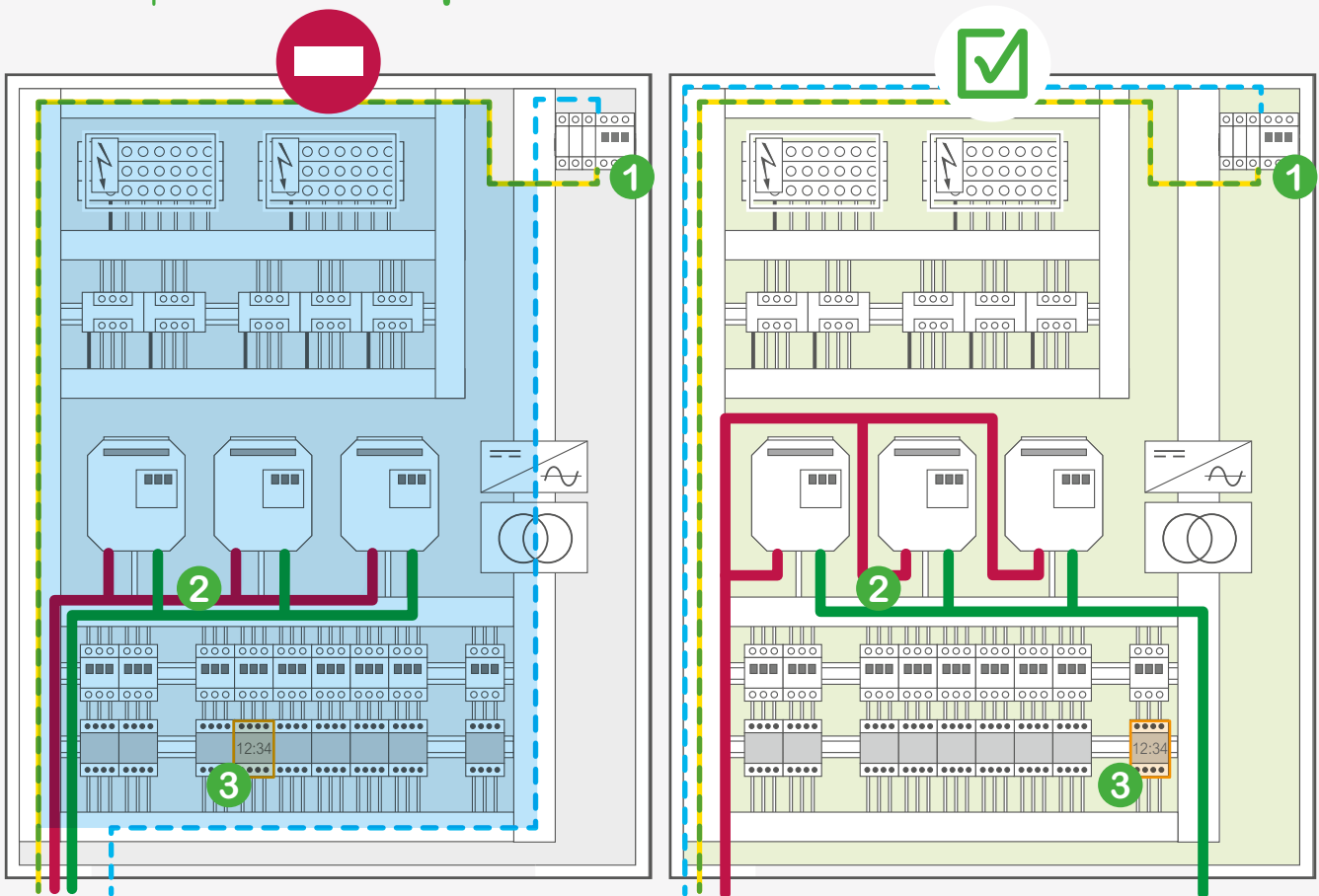

The power and earth cables of the panel form a large loop shown in blue. The presence of a surge protective device will facilitate the flow of a high current in the event of a lightning shock. (\*)

The upstream and downstream power cables of the variable speed drives run alongside one another, creating a transfer of disturbance.

A time switch is installed between two contactors. It risks malfunctions during contactor switching.

- 1 The cables are held against one another to reduce the surface area of the inductive loop.
- 2 The upstream and downstream cables follow separate paths. If necessary, they cross one another at right angles. The disturbing cable is shielded; it is held against the back plate.
- 3 The time switch is remote from the contactors.

(\*) Refer to the surge arrester wiring instructions: Control Panel Technical Guide - "How to protect a machine from malfunctions due to voltage surge" ref.: CPTG002\_EN



# Panel wiring

## 5 > Earth connection of shielding

### 1 Connection of shielding terminations

The shieldings are stopped as close as possible to the equipment to which the cables are connected. Connection is performed carefully, clamping the shielding with a clamp which will be:

- fastened to an earth terminal strip or
- fastened to the panel's earthing plate.

To avoid corrosion problems, the use of galvanised steel on shielding made of tinned copper and aluminum must be avoided. Stainless steel is the recommended material.

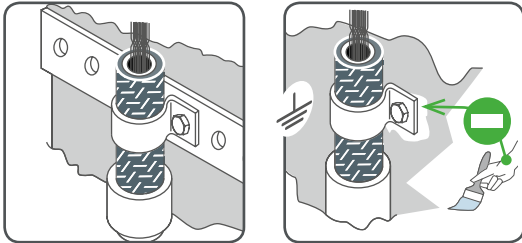

### 2 Connection of cables "on standby"

Wires not connected to a potential difference constitute antennas collecting and radiating high-frequency disturbance. This phenomenon can be cancelled by connecting them to the closest frame earth.

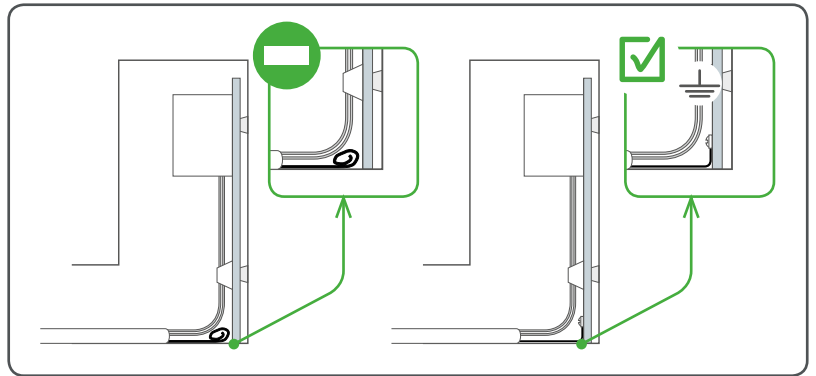

## 6 > Earth connection of metal raceways

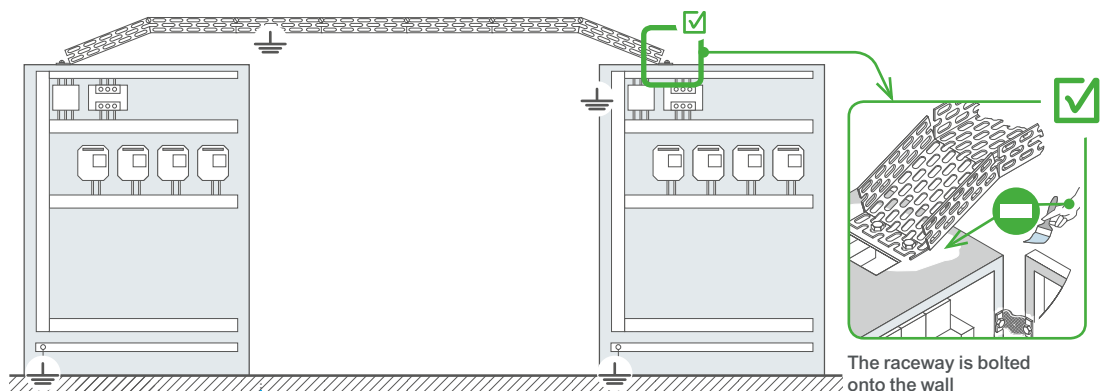
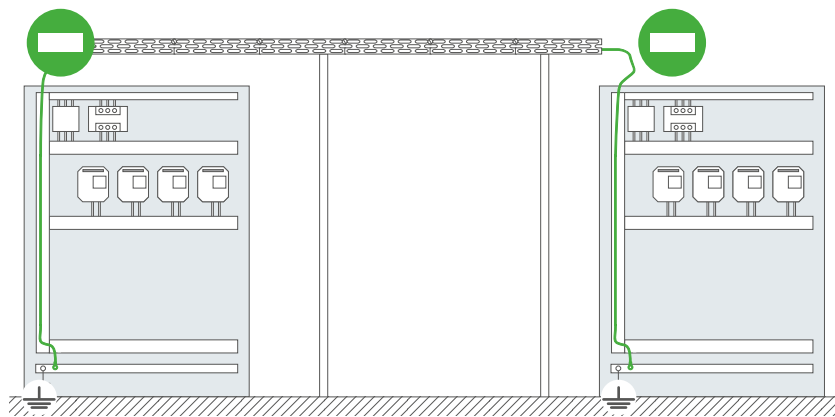



# Guide for selection of "EMC" products

# Enclosures and panels with strengthened EMC

## Spacial product range for hostile environments

### Spacial S3HF

#### Monobloc wall-mounting enclosure

- IP55 - IK10
- from H 400 x W 300 x D 200 mm to H 1200 x W 800 x D 300 mm



### Spacial SMHF

#### Monobloc panel

- IP55 - IK10
- from H 1800 x W 800 x D 400 mm to H 2000 x W 800 x D 600 mm

### Spacial SFHF

#### Composable panel

- IP55 - IK10
- from H 1800 x W 600 x D 600 mm to H 2200 x W 800 x D 800 mm



The Spacial S3HF, SFHF and SMHF enclosures can attenuate EMC electromagnetic disturbance in industrial environments.

#### These enclosures perform two functions:

- 1 Provide shielding by acting as a Faraday cage.
- 2 Provide effective protection for sensitive equipment through galvanized sheet metal frames, in compliance with the installation rules.

### Construction

- **Spacial S3HF:** these enclosures consist of a single folded and welded Aluzinc 150 metal sheet.
- **Spacial SMHF:** these panels are designed based on a sheet metal skirt executed in one piece. To this is added a reinforced, welded back. The metal sheet consists of 55 % aluminium as a surface coating to ensure good reflection of electromagnetic waves. A special metal-sheathed seal ensures the necessary electrical continuity at the level of the panels, doors and associated devices while ensuring overall watertightness.
- **Spacial SFHF:** these panels are designed around a frame consisting of closed galvanized steel sections. This frame receives the doors, panels and a roof, all made of Aluzinc 150 sheet metal.

### Fields of application

#### These enclosures are especially suitable for sensitive equipment:

- programmable logic controllers,
- electronic circuits and cards, etc.

They provide protection from the main disturbing factors: variable speed drives, motors, transformers/rectifiers, power cables, etc.

# Fans and accessories for strengthened EMC



## IP54 EMC Fan

To effectively protect the equipment against electromagnetic disruptions, the EMC fan is equipped with:

- a steel frame covering the plastic elements (self-extinguishing ABS according to standard UL 94 V-0),
- a metal grille attached to the frame,
- a beryllium gasket guaranteeing conductivity between the perimeter of the fan unit and the enclosure.

Dimensions (mm)		Flow rate	Voltage	References
External	Cut-out	(m <sup>3</sup> /h)	(V)	
145 x 145 x 70	126 x 126	61	230	<b>NSY17990</b>
252 x 252 x 97	224 x 224	156	230	<b>NSY17991</b>
320 x 320 x 150	292 x 292	480	230	<b>NSY17992</b>



## IP54 EMC outlet grille

Grille equipped with:

- a steel frame covering the plastic elements (self-extinguishing ABS according to standard UL 94 V-0),
- a metal grille attached to the frame,
- a beryllium gasket guaranteeing conductivity between the perimeter of the grille and the enclosure.

Dimensions (mm)		References
External	Cut-out	
145 x 145 x 70	126 x 126	<b>NSY17996</b>
252 x 252 x 97	224 x 224	<b>NSY17997</b>
320 x 320 x 150	292 x 292	<b>NSY17998</b>



## EMC cover IP55

- This solution guarantees protection against electromagnetic disruptions and guarantees IP55.
- The EMC cover is installed on the fans or standard IP54 outlet grilles.
- The cover, designed in sheet-steel painted for outdoor use, completely covers the fan or outlet grille.
- Conductivity is obtained by means of:
  - a conductive coating (2 Ω),
  - a conductive copper braid.
- Ingress protection rating: IP55.
- Ingress protection rating: IK10.
- RAL 7035 grey.
- Absorption curve according to standard IEE 299 1997 (UNE 50147-1).

Flow rate (m <sup>3</sup> /h)*		Dimensions (mm)		References		Fan	Grille
Free	With 1 outlet grille	External	Cut-out	Cover	Spare filter for cover		
				Sheet-steel painted RAL 7035	Minor pack. 5 p	RAL 7035	RAL 7035
74	53	240 x 180 x 60	125 x 125	<b>NSYCAP125LE</b>	<b>NSYCAF125L55</b>	<b>NSYCVF85M230PF</b>	<b>NSYCAG125L55</b>
110	82	350 x 305 x 80	223 x 223	<b>NSYCAP223LE</b>	<b>NSYCAF223L55</b>	<b>NSYCVF165M230PF</b>	<b>NSYCAG223L55</b>
165	123	350 x 305 x 80	223 x 223	<b>NSYCAP223LE</b>	<b>NSYCAF223L55</b>	<b>NSYCVF300M230PF</b>	<b>NSYCAG223L55</b>
316	265	430 x 373 x 105	291 x 291	<b>NSYCAP291LE</b>	<b>NSYCAF291L55</b>	<b>NSYCVF560M230PF</b>	<b>NSYCAG291L55</b>
502	430	430 x 373 x 105	291 x 291	<b>NSYCAP291LE</b>	<b>NSYCAF291L55</b>	<b>NSYCVF850M230PF</b>	<b>NSYCAG291L55</b>

\*The impact on the flow rates of the fans with different voltages is similar to the impact of the 230 V fans.



# Accessories for strengthening EMC



## Bonding braid

- Tinned copper.
- Nuts and washers not supplied.
- Unit references but to be ordered in multiples of 10.

Length (mm)	Width (mm)	Cross section (mm <sup>2</sup> )	Hole dia. (mm)	References
150	12	6	6.5	<b>NSYEB156D6</b>
150	17	10	6.5	<b>NSYEB1510D6</b>
155	17	16	8.5	<b>NSYEB1516D8</b>
200	27	25	8.5	<b>NSYEB2025D8</b>
200	33	50	8.5	<b>NSYEB2050D8</b>

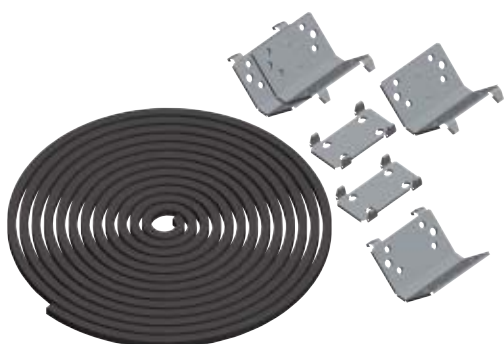

## EMC coupling kit

- Used to join enclosures side-by-side or depthwise.
- Special gasket for EMC solution.
- Attenuation level is decreased by 5 db when enclosures are joined (please consult us).
- Ingress protection rating: IP55.

Panel length (mm)	Panel width (mm)	Kit references
1800	400	<b>NSYSFHFBK184</b>
	600	<b>NSYSFHFBK186</b>
2000	400	<b>NSYSFHFBK204</b>
	600	<b>NSYSFHFBK206</b>
	800	<b>NSYSFHFBK208</b>
	1000	<b>NSYSFHFBK2010</b>
2200	600	<b>NSYSFHFBK226</b>
	800	<b>NSYSFHFBK228</b>



## Other accessories

Our partner company, Jacques Dubois – [www.jacquesdubois.com](http://www.jacquesdubois.com) – is a specialist in the manufacture of products to strengthen EMC:

- sheet gaskets;
- linear gaskets;
- cable shielding;
- aperture shielding, etc.

# Useful documents

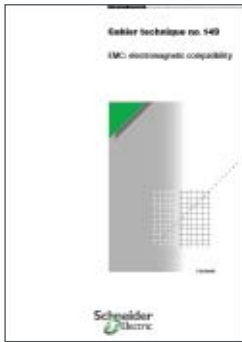

**Cahier technique n°149**  
EMC: electromagnetic compatibility.  
Ref.: CT149.pdf



**Electrical installation guide 2010**  
According to IEC international standards.  
Ref.: EIGED306001EN



**Chapter R of the Electrical Installation Guide**  
EMC guidelines.



**Control Panel Technical Guide**  
How to prevent machine malfunctions and electronic damage due to voltage surges?  
Ref.: CPTG002\_EN

# Useful links



[http://www.electrical-installation.org/enwiki/ElectroMagnetic\\_Compatibility\\_%28EMC%29](http://www.electrical-installation.org/enwiki/ElectroMagnetic_Compatibility_%28EMC%29)





**Schneider Electric Industries SAS**

35, rue Joseph Monier  
CS 30323  
92506 Rueil Malmaison Cedex  
France

RCS Nanterre 954 503 439  
Capital social 896 313 776 €  
[www.schneider-electric.com](http://www.schneider-electric.com)

04-2017  
CPTG003\_EN

© 2017 - Schneider Electric - All rights reserved.  
All trademarks are owned by Schneider Electric Industries SAS or its affiliated companies.

This document has been  
printed on recycled paper.

