

**SIEMENS**

# SINAMICS

## SINAMICS S120

Control Units and supplementary system components

Manual

Edition

04/2015

Answers for industry.



# SIEMENS

## SINAMICS

### S120 Control Units and additional system components



Manual

<u>Preface</u>	
<u>Fundamental safety instructions</u>	<b>1</b>
<u>System overview</u>	<b>2</b>
<u>Control Units and operating elements</u>	<b>3</b>
<u>Option boards</u>	<b>4</b>
<u>Terminal Modules</u>	<b>5</b>
<u>Hub Modules</u>	<b>6</b>
<u>Voltage Sensing Module VSM10</u>	<b>7</b>
<u>Encoder system connection</u>	<b>8</b>
<u>Cabinet design and electromagnetic compatibility (EMC)</u>	<b>9</b>
<u>Appendix</u>	<b>A</b>

## Legal information

### Warning notice system

This manual contains notices you have to observe in order to ensure your personal safety, as well as to prevent damage to property. The notices referring to your personal safety are highlighted in the manual by a safety alert symbol, notices referring only to property damage have no safety alert symbol. These notices shown below are graded according to the degree of danger.

 <b>DANGER</b>
indicates that death or severe personal injury <b>will</b> result if proper precautions are not taken.
 <b>WARNING</b>
indicates that death or severe personal injury <b>may</b> result if proper precautions are not taken.
 <b>CAUTION</b>
indicates that minor personal injury can result if proper precautions are not taken.
<b>NOTICE</b>
indicates that property damage can result if proper precautions are not taken.

If more than one degree of danger is present, the warning notice representing the highest degree of danger will be used. A notice warning of injury to persons with a safety alert symbol may also include a warning relating to property damage.

### Qualified Personnel

The product/system described in this documentation may be operated only by **personnel qualified** for the specific task in accordance with the relevant documentation, in particular its warning notices and safety instructions. Qualified personnel are those who, based on their training and experience, are capable of identifying risks and avoiding potential hazards when working with these products/systems.

### Proper use of Siemens products

Note the following:

 <b>WARNING</b>
Siemens products may only be used for the applications described in the catalog and in the relevant technical documentation. If products and components from other manufacturers are used, these must be recommended or approved by Siemens. Proper transport, storage, installation, assembly, commissioning, operation and maintenance are required to ensure that the products operate safely and without any problems. The permissible ambient conditions must be complied with. The information in the relevant documentation must be observed.

### Trademarks

All names identified by ® are registered trademarks of Siemens AG. The remaining trademarks in this publication may be trademarks whose use by third parties for their own purposes could violate the rights of the owner.

### Disclaimer of Liability

We have reviewed the contents of this publication to ensure consistency with the hardware and software described. Since variance cannot be precluded entirely, we cannot guarantee full consistency. However, the information in this publication is reviewed regularly and any necessary corrections are included in subsequent editions.

# Preface

## SINAMICS documentation

The SINAMICS documentation is organized in the following categories:

- General documentation/catalogs
- User documentation
- Manufacturer/service documentation

## Additional information

You can find information on the following topics at the following address (<http://w3.siemens.com/mcms/mc-solutions/en/motion-control/support/technical-documentation/Pages/technical-documentation.aspx>):

- Ordering documentation/overview of documentation
- Additional links to download documents
- Using documentation online (find and search in manuals/information)

Please send any questions about the technical documentation (e.g. suggestions for improvement, corrections) to the following e-mail address (<mailto:docu.motioncontrol@siemens.com>).

## My Documentation Manager

At the following address (<http://www.siemens.com/mdm>), you can find information on how to create your own individual documentation based on Siemens' content, and adapt it for your own machine documentation.

## Training

At the following address (<http://www.siemens.com/sitrain>), you can find information about SITRAIN (Siemens training on products, systems and solutions for automation and drives).

## FAQs

You can find Frequently Asked Questions in the Service&Support pages under Product Support (<https://support.industry.siemens.com/cs/de/en/ps/faq>).

## SINAMICS

You can find information about SINAMICS at the following address (<http://www.siemens.com/sinamics>).

Usage phases and their documents/tools (as an example)

Table 1 Usage phases and the available documents/tools

Usage phase	Document/tool
Orientation	SINAMICS S Sales Documentation
Planning/configuration	<ul style="list-style-type: none"> <li>• SIZER Engineering Tool</li> <li>• Configuration Manuals, Motors</li> </ul>
Deciding/ordering	SINAMICS S120 catalogs <ul style="list-style-type: none"> <li>• SIMOTION, SINAMICS S120 and Motors for Production Machines (Catalog PM 21)</li> <li>• SINAMICS and Motors for Single-axis Drives (Catalog D 31)</li> <li>• SINUMERIK &amp; SINAMICS Equipment for Machine Tools (Catalog NC 61)</li> <li>• SINUMERIK 840D sl Type 1B Equipment for Machine Tools (Catalog NC 62)</li> </ul>
Installation/assembly	<ul style="list-style-type: none"> <li>• SINAMICS S120 Manual for Control Units and Additional System Components</li> <li>• SINAMICS S120 Manual for Booksize Power Units</li> <li>• SINAMICS S120 Manual for Chassis Power Units</li> <li>• SINAMICS S120 Manual for AC Drives</li> <li>• SINAMICS S120M Manual Distributed Drive Technology</li> <li>• SINAMICS S120 Manual Power Units Booksize C/D Type</li> <li>• SINAMICS HLA System Manual Hydraulic Drive</li> </ul>
Commissioning	<ul style="list-style-type: none"> <li>• STARTER Commissioning Tool</li> <li>• SINAMICS S120 Getting Started</li> <li>• SINAMICS S120 Commissioning Manual</li> <li>• SINAMICS S120 CANopen Commissioning Manual</li> <li>• SINAMICS S120 Function Manual</li> <li>• SINAMICS S120 Safety Integrated Function Manual</li> <li>• SINAMICS S120/S150 List Manual</li> <li>• SINAMICS HLA System Manual Hydraulic Drive</li> </ul>
Usage/operation	<ul style="list-style-type: none"> <li>• SINAMICS S120 Commissioning Manual</li> <li>• SINAMICS S120/S150 List Manual</li> <li>• SINAMICS HLA System Manual Hydraulic Drive</li> </ul>
Maintenance/servicing	<ul style="list-style-type: none"> <li>• SINAMICS S120 Commissioning Manual</li> <li>• SINAMICS S120/S150 List Manual</li> </ul>
References	<ul style="list-style-type: none"> <li>• SINAMICS S120/S150 List Manual</li> </ul>

## Target group

This documentation is intended for machine manufacturers, commissioning engineers, and service personnel who use the SINAMICS drive system.

## Benefits

This manual provides all of the information, procedures and operator actions required for the particular usage phase.

## Standard scope

The scope of the functionality described in this document can differ from that of the drive system that is actually supplied.

- Other functions not described in this documentation might be able to be executed in the drive system. However, no claim can be made regarding the availability of these functions when the equipment is first supplied or in the event of service.
- The documentation can also contain descriptions of functions that are not available in a particular product version of the drive system. The functionality of the supplied drive system should only be taken from the ordering documentation.
- Extensions or changes made by the machine manufacturer must be documented by the machine manufacturer.

For reasons of clarity, this documentation does not contain all of the detailed information on all of the product types, and cannot take into consideration every conceivable type of installation, operation and service/maintenance.

## Technical Support

Country-specific telephone numbers for technical support are provided in the Internet at the following address (<https://support.industry.siemens.com/sc/ww/en/sc/2090>) in the "Contact" area.

## EC Declaration of Conformity, certificates, certifications, manufacturers declarations

You can find the EC Declaration of Conformity for the relevant directives as well as the relevant certificates, prototype test certificates, manufacturers declarations and test certificates for functions relating to functional safety ("Safety Integrated") in the Internet at the following address (<https://support.industry.siemens.com/cs/ww/en/ps/13231/cert>).

You can obtain an up-to-date list of currently certified components on request from your local Siemens office. If you have any questions relating to certifications that have not yet been completed, please ask your Siemens contact person.

---

#### Note

You can find certificates for the North American market on the Internet page of the certifier:

- For products with UL certificate (<http://database.ul.com/cgi-bin/XYV/template/LISEXT/1FRAME/index.html>)
  - For products with TÜV SÜD certificate ([https://www.tuev-sued.de/industry\\_and\\_consumer\\_products/certificates](https://www.tuev-sued.de/industry_and_consumer_products/certificates))
  - For products with CSA certificate (<http://www.csagroup.org/de/en/services/testing-and-certification/certified-product-listing>)
- 

### Low-Voltage Directive

When operated in dry areas, SINAMICS S units conform to the Low-Voltage Directive 2006/95/EC.

### EMC directive

SINAMICS S devices fulfill EMC Directive 89/336/EEC or 2014/130/EEC in the configuration specified in the associated EC Declaration of Conformity for EMC and when the Configuration Manual EMC Installation Guideline, article number 6FC5297-0AD30-0□P□, is implemented.

### EMC limit values in South Korea

<p>이 기기는 업무용(A급) 전자파적합기기로서 판매자 또는 사용자는 이 점을 주의하시기 바라며, 가정외의 지역에서 사용하는 것을 목적으로 합니다.</p> <p>For sellers or other users, please bear in mind that this device is an A-grade electromagnetic wave device. This device is intended to be used in areas other than at home.</p>
---

The EMC limit values to be observed for Korea correspond to the limit values of the EMC product standard for variable-speed electric drives EN 61800-3 of category C2 or the limit value class A, Group 1 to CISPR11. By implementing appropriate additional measures, the limit values according to category C2 or limit value class A, Group 1, are observed. Further, additional measures may be required, such as using an additional radio interference suppression filter (EMC filter).

The measures for EMC-compliant design of the system are described in detail in this manual respectively in the EMC Installation Guideline Configuration Manual.

The final statement regarding compliance with the standard is given by the respective label attached to the individual unit.



## Ensuring reliable operation

The manual describes a desired state which, if maintained, ensures the required level of operational reliability and compliance with EMC limit values.



Should there be any deviation from the requirements in the manual, appropriate actions (e.g. measurements) must be taken to check/prove that the required level of operational reliability and compliance with EMC limit values are ensured.

## Spare parts

Spare parts are available on the Internet at the following address (<https://support.industry.siemens.com/sc/ww/en/sc/2110>).

## Ground symbols

Table 2 Symbols

Symbol	Meaning
	Connection for protective conductor (PE)
	Ground (e.g. M 24 V)
	Connection for function potential bonding



# Table of contents

	<b>Preface</b> .....	<b>5</b>
<b>1</b>	<b>Fundamental safety instructions</b> .....	<b>19</b>
1.1	General safety instructions .....	19
1.2	Safety instructions for electromagnetic fields (EMF) .....	23
1.3	Handling electrostatic sensitive devices (ESD) .....	23
1.4	Industrial security .....	24
1.5	Residual risks of power drive systems .....	25
<b>2</b>	<b>System overview</b> .....	<b>27</b>
2.1	Field of application .....	27
2.2	Platform Concept and Totally Integrated Automation .....	28
2.3	Introduction .....	30
2.4	SINAMICS S120 components .....	32
2.5	Power units .....	34
2.6	System data .....	35
2.7	Recycling and disposal .....	36
<b>3</b>	<b>Control Units and operating elements</b> .....	<b>37</b>
3.1	Introduction .....	37
3.2	Safety instructions for Control Units .....	40
3.3	Control Unit CU320-2 PN (PROFINET) .....	42
3.3.1	Description .....	42
3.3.2	Interface description .....	43
3.3.2.1	Overview .....	43
3.3.2.2	X100-X103 DRIVE-CLiQ interfaces .....	45
3.3.2.3	X122 digital inputs/outputs .....	46
3.3.2.4	X132 digital inputs/outputs .....	48
3.3.2.5	X124 electronics power supply .....	49
3.3.2.6	X127 LAN (Ethernet) .....	50
3.3.2.7	X140 serial interface (RS232) .....	51
3.3.2.8	X150 P1/P2 PROFINET .....	51
3.3.2.9	Measuring socket .....	52
3.3.2.10	Buttons .....	52
3.3.2.11	Slot for memory card .....	53
3.3.3	Connection example .....	55
3.3.4	Meaning of the LEDs .....	56
3.3.4.1	Description of the LED statuses .....	56
3.3.4.2	Behavior of the LEDs during booting .....	56
3.3.4.3	Behavior of the LEDs in the operating state .....	57

3.3.5	Dimension drawing .....	58
3.3.6	Technical data.....	59
3.4	Control Unit CU320-2 DP (PROFIBUS).....	59
3.4.1	Description .....	59
3.4.2	Interface description.....	60
3.4.2.1	Overview .....	60
3.4.2.2	X100-X103 DRIVE-CLiQ interfaces .....	62
3.4.2.3	X122 digital inputs/outputs .....	63
3.4.2.4	X132 digital inputs/outputs .....	65
3.4.2.5	X124 electronics power supply .....	66
3.4.2.6	X126 PROFIBUS .....	67
3.4.2.7	PROFIBUS address switch.....	68
3.4.2.8	X127 LAN (Ethernet).....	69
3.4.2.9	X140 serial interface (RS232).....	70
3.4.2.10	Measuring socket.....	70
3.4.2.11	Buttons .....	71
3.4.2.12	Slot for memory card.....	71
3.4.3	Connection example .....	73
3.4.4	Meaning of the LEDs .....	74
3.4.4.1	Description of the LED statuses.....	74
3.4.4.2	Behavior of the LEDs during booting .....	74
3.4.4.3	Behavior of the LEDs in the operating state .....	75
3.4.5	Dimension drawing .....	76
3.4.6	Technical data.....	77
3.5	Mounting Control Units .....	78
3.5.1	Mounting to a Line Module.....	78
3.5.2	Mounting on the mounting surface.....	80
3.5.3	Opening and removing the cover.....	81
3.6	Basic Operator Panel BOP20 .....	82
3.6.1	Description .....	82
3.6.2	Interface description.....	82
3.6.3	Mounting at the Control Unit .....	84
3.6.4	Removal.....	86
<b>4</b>	<b>Option boards .....</b>	<b>87</b>
4.1	Safety instructions for option boards.....	87
4.2	CAN Communication Board CBC10 .....	88
4.2.1	Description .....	88
4.2.2	Interface description.....	88
4.2.2.1	Overview .....	88
4.2.2.2	X451 CAN bus interface .....	89
4.2.2.3	X452 CAN bus interface .....	89
4.2.2.4	2-pin SMD DIL switch .....	90
4.2.3	Meaning of the LED .....	91
4.2.4	Installation .....	92
4.2.5	Technical data.....	92
4.3	Communication Board Ethernet CBE20 .....	93
4.3.1	Description .....	93
4.3.2	Interface description.....	93
4.3.2.1	Overview .....	93

4.3.2.2	X1400 Ethernet interface .....	94
4.3.3	Meaning of the LEDs .....	94
4.3.4	Installation .....	96
4.3.5	Technical data .....	97
4.4	Terminal Board TB30 .....	98
4.4.1	Description .....	98
4.4.2	Interface description .....	98
4.4.2.1	Overview .....	98
4.4.2.2	X424 power supply, digital outputs .....	99
4.4.2.3	X481 digital inputs/outputs .....	100
4.4.2.4	X482 analog inputs/outputs .....	101
4.4.3	Connection example .....	102
4.4.4	Installation .....	103
4.4.5	Shield support .....	104
4.4.6	Technical data .....	104
<b>5</b>	<b>Terminal Modules .....</b>	<b>105</b>
5.1	Safety instructions for Terminal Modules .....	105
5.2	Terminal Module TM15 .....	106
5.2.1	Description .....	106
5.2.2	Interface description .....	107
5.2.2.1	Overview .....	107
5.2.2.2	X500/X501 DRIVE-CLiQ interfaces .....	108
5.2.2.3	X520 bidirectional digital inputs/outputs .....	109
5.2.2.4	X521 bidirectional digital inputs/outputs .....	110
5.2.2.5	X522 bidirectional digital inputs/outputs .....	111
5.2.2.6	X524 Electronics power supply .....	111
5.2.3	Connection example .....	112
5.2.4	Meaning of the LED .....	113
5.2.5	Dimension drawing .....	114
5.2.6	Installation .....	115
5.2.7	Protective conductor connection and shield support .....	116
5.2.8	Connector coding .....	117
5.2.9	Technical data .....	118
5.3	Terminal Module TM31 .....	119
5.3.1	Description .....	119
5.3.2	Interface description .....	120
5.3.2.1	Overview .....	120
5.3.2.2	X500/X501 DRIVE-CLiQ interfaces .....	121
5.3.2.3	X520 digital inputs .....	121
5.3.2.4	X521 analog inputs .....	122
5.3.2.5	S5 current/voltage changeover switch for analog inputs .....	123
5.3.2.6	X522 analog outputs/temperature sensor .....	124
5.3.2.7	X524 Electronics power supply .....	125
5.3.2.8	X530 digital inputs .....	125
5.3.2.9	X540 auxiliary voltage for the digital inputs .....	126
5.3.2.10	X541 bidirectional digital inputs/outputs .....	127
5.3.2.11	X542 relay outputs .....	128
5.3.3	Connection example .....	129
5.3.4	Meaning of the LED .....	130
5.3.5	Dimension drawing .....	131

5.3.6	Installation .....	132
5.3.7	Protective conductor connection and shield support .....	133
5.3.8	Connector coding .....	134
5.3.9	Technical data .....	135
5.4	Terminal Module TM41 .....	136
5.4.1	Description .....	136
5.4.2	Interface description .....	137
5.4.2.1	Overview .....	137
5.4.2.2	X500/X501 DRIVE-CLiQ interfaces .....	138
5.4.2.3	X524 electronics power supply .....	138
5.4.2.4	X520 encoder interface .....	139
5.4.2.5	X521 bidirectional digital inputs/outputs .....	140
5.4.2.6	X522 isolated digital inputs .....	141
5.4.2.7	X523 analog input .....	142
5.4.3	Connection example .....	143
5.4.4	Meaning of the LEDs .....	144
5.4.5	Dimension drawing .....	145
5.4.6	Installation .....	146
5.4.7	Protective conductor connection and shield support .....	147
5.4.8	Technical data .....	148
5.5	Terminal Module TM54F .....	149
5.5.1	Description .....	149
5.5.2	Interface description .....	150
5.5.2.1	Overview .....	150
5.5.2.2	X500/X501 DRIVE-CLiQ interfaces .....	151
5.5.2.3	X514 power supply for digital outputs and sensors .....	151
5.5.2.4	X520 sensor power supply .....	152
5.5.2.5	X521 fail-safe digital inputs + power supply with forced dormant error detection .....	152
5.5.2.6	X522 fail-safe digital inputs .....	154
5.5.2.7	X523 fail-safe digital output .....	155
5.5.2.8	X524 electronics power supply .....	155
5.5.2.9	X525 fail-safe digital output .....	156
5.5.2.10	X531 fail-safe digital inputs + power supply with forced dormant error detection .....	157
5.5.2.11	X532 fail-safe digital inputs .....	158
5.5.2.12	X533 fail-safe digital output .....	159
5.5.2.13	X535 fail-safe digital output .....	160
5.5.3	Connection example .....	161
5.5.4	Meaning of the LEDs .....	162
5.5.5	Dimension drawing .....	164
5.5.6	Installation .....	165
5.5.7	Protective conductor connection and shield support .....	166
5.5.8	Technical data .....	167
5.6	Terminal Module TM120 .....	168
5.6.1	Description .....	168
5.6.2	Interface description .....	169
5.6.2.1	Overview .....	169
5.6.2.2	X500/X501 DRIVE-CLiQ interfaces .....	170
5.6.2.3	X521 temperature sensor input .....	171
5.6.2.4	X524 Electronics power supply .....	173
5.6.3	Connection examples .....	174
5.6.4	Meaning of the LED .....	175

5.6.5	Dimension drawing .....	176
5.6.6	Installation .....	177
5.6.7	Protective conductor connection and shield support .....	178
5.6.8	Technical data .....	179
5.7	Terminal Module TM150 .....	179
5.7.1	Description .....	179
5.7.2	Interface description .....	180
5.7.2.1	Overview .....	180
5.7.2.2	X500/X501 DRIVE-CLiQ interfaces .....	181
5.7.2.3	X524 Electronics power supply .....	181
5.7.2.4	X531-X536 temperature sensor inputs .....	182
5.7.3	Connection examples .....	184
5.7.4	Meaning of the LED .....	186
5.7.5	Dimension drawing .....	187
5.7.6	Installation .....	188
5.7.7	Protective conductor connection and shield support .....	189
5.7.8	Technical data .....	190
<b>6</b>	<b>Hub Modules.....</b>	<b>191</b>
6.1	Safety instructions for Hub Modules .....	191
6.2	DRIVE-CLiQ Hub Module DMC20 .....	192
6.2.1	Description .....	192
6.2.2	Interface description .....	193
6.2.2.1	Overview .....	193
6.2.2.2	X500-X505 DRIVE-CLiQ interfaces .....	194
6.2.2.3	X524 Electronics power supply .....	194
6.2.3	Meaning of the LED .....	195
6.2.4	Dimension drawing .....	196
6.2.5	Installation .....	197
6.2.6	Protective conductor connection and shield support .....	199
6.2.7	Technical data .....	199
6.3	DRIVE-CLiQ Hub Module External DME20 .....	200
6.3.1	Description .....	200
6.3.2	Interface description .....	201
6.3.2.1	Overview .....	201
6.3.2.2	X500-X505 DRIVE-CLiQ interfaces .....	202
6.3.2.3	X524 Electronics power supply .....	202
6.3.3	Dimension drawing .....	204
6.3.4	Installation .....	205
6.3.5	Technical data .....	205
6.3.6	Specifications for use with UL approval .....	206
<b>7</b>	<b>Voltage Sensing Module VSM10 .....</b>	<b>207</b>
7.1	Description .....	207
7.2	Safety instructions for the Voltage Sensing Module (VSM10) .....	208
7.3	Interface description .....	210
7.3.1	Overview .....	210
7.3.2	X500 DRIVE-CLiQ interface .....	211
7.3.3	X520 analog inputs/temperature sensor .....	212
7.3.4	X521 three-phase voltage sensing up to 100 V 3-ph. AC .....	214

7.3.5	X522 three-phase voltage sensing up to 690 V 3-ph. AC .....	214
7.3.6	X524 Electronics power supply .....	215
7.3.7	X530 neutral point grounding .....	216
7.4	Connection example .....	217
7.5	Meaning of the LED .....	219
7.6	Dimension drawing .....	220
7.7	Installation .....	221
7.8	Protective conductor connection and shield support .....	222
7.9	Operation on an isolated-neutral system (IT system) .....	223
7.10	Technical data .....	223
7.11	Service and maintenance .....	224
<b>8</b>	<b>Encoder system connection .....</b>	<b>225</b>
8.1	Introduction .....	225
8.2	Overview of Sensor Modules .....	226
8.3	Safety instructions for Sensor Modules and encoders .....	228
8.4	Sensor Module Cabinet-Mounted SMC10 .....	230
8.4.1	Description .....	230
8.4.2	Interface description .....	231
8.4.2.1	Overview .....	231
8.4.2.2	X500 DRIVE-CLiQ interface .....	232
8.4.2.3	X520 encoder system interface .....	233
8.4.2.4	X524 Electronics power supply .....	234
8.4.3	Connection example .....	235
8.4.4	Meaning of the LED .....	235
8.4.5	Dimension drawing .....	236
8.4.6	Mounting .....	237
8.4.7	Technical data .....	238
8.5	Sensor Module Cabinet-Mounted SMC20 .....	240
8.5.1	Description .....	240
8.5.2	Interface description .....	241
8.5.2.1	Overview .....	241
8.5.2.2	X500 DRIVE-CLiQ interface .....	242
8.5.2.3	X520 encoder system interface .....	243
8.5.2.4	X524 Electronics power supply .....	244
8.5.3	Connection example .....	245
8.5.4	Meaning of the LED .....	245
8.5.5	Dimension drawing .....	246
8.5.6	Mounting .....	247
8.5.7	Technical data .....	248
8.6	Sensor Module Cabinet-Mounted SMC30 .....	249
8.6.1	Description .....	249
8.6.2	Interface description .....	250
8.6.2.1	Overview .....	250
8.6.2.2	X500 DRIVE-CLiQ interface .....	251
8.6.2.3	X520 encoder system interface .....	252



8.6.2.4	X521 / X531 alternative encoder system interface .....	254
8.6.2.5	X524 Electronics power supply .....	255
8.6.3	Connection examples .....	256
8.6.4	Meaning of the LEDs .....	258
8.6.5	Dimension drawing .....	259
8.6.6	Mounting .....	260
8.6.7	Protective conductor connection and shield support .....	261
8.6.8	Technical data .....	262
8.7	Sensor Module Cabinet-Mounted SMC40 .....	267
8.7.1	Description .....	267
8.7.2	Interface descriptions .....	268
8.7.2.1	Overview .....	268
8.7.2.2	X500/1 and X500/2 DRIVE-CLiQ interfaces .....	269
8.7.2.3	X520/1 and X520/2 encoder system interfaces .....	270
8.7.2.4	X524 Electronics power supply .....	271
8.7.3	Connection example .....	272
8.7.4	Meaning of the LEDs .....	273
8.7.5	Dimension drawing .....	274
8.7.6	Installation .....	275
8.7.7	Technical data .....	276
8.8	Sensor Module External SME20 .....	277
8.8.1	Description .....	277
8.8.2	Interface description .....	277
8.8.2.1	Overview .....	277
8.8.2.2	DRIVE-CLiQ interface .....	278
8.8.2.3	Encoder system interface .....	279
8.8.3	Connection example .....	280
8.8.4	Dimension drawing .....	281
8.8.5	Installation .....	281
8.8.6	Technical data .....	282
8.9	Sensor Module External SME25 .....	284
8.9.1	Description .....	284
8.9.2	Interface description .....	284
8.9.2.1	Overview .....	284
8.9.2.2	DRIVE-CLiQ interface .....	285
8.9.2.3	Encoder system interface .....	286
8.9.3	Connection example .....	286
8.9.4	Dimension drawing .....	287
8.9.5	Installation .....	287
8.9.6	Technical data .....	288
8.10	Sensor Module External SME120 .....	290
8.10.1	Description .....	290
8.10.2	Safety instructions for Sensor Modules External .....	290
8.10.3	Interface description .....	292
8.10.3.1	Overview .....	292
8.10.3.2	X100 encoder system interface .....	292
8.10.3.3	X200 thermistor sensor input .....	293
8.10.3.4	X300 hall sensor input .....	294
8.10.3.5	X500 DRIVE-CLiQ interface .....	294
8.10.4	Connection examples .....	295

8.10.5	Dimension drawing .....	300
8.10.6	Installation .....	300
8.10.7	Technical data .....	301
8.11	Sensor Module External SME125 .....	303
8.11.1	Description .....	303
8.11.2	Safety instructions for Sensor Modules External .....	304
8.11.3	Interface description .....	305
8.11.3.1	Overview .....	305
8.11.3.2	X100 encoder system interface .....	306
8.11.3.3	X200 thermistor sensor input .....	307
8.11.3.4	X500 DRIVE-CLiQ interface .....	308
8.11.4	Connection examples .....	309
8.11.5	Dimension drawing .....	314
8.11.6	Installation .....	314
8.11.7	Technical data .....	315
8.12	DRIVE-CLiQ encoder .....	317
8.12.1	Description .....	317
8.12.2	Interface description .....	317
8.12.2.1	Overview .....	317
8.12.2.2	DRIVE-CLiQ interface .....	318
8.12.3	Dimension drawings .....	318
8.12.4	Installation .....	320
8.12.5	Technical data .....	323
<b>9</b>	<b>Cabinet design and electromagnetic compatibility (EMC) .....</b>	<b>325</b>
9.1	Tightening torques for screws and screw connections .....	325
9.2	Information on control cabinet installation and EMC .....	326
<b>A</b>	<b>Appendix .....</b>	<b>327</b>
A.1	List of abbreviations .....	327
A.2	Terminal description .....	336
A.2.1	Spring-loaded terminals .....	336
A.2.2	Screw terminals .....	336
A.3	Cable lugs .....	338
A.4	Documentation overview .....	339
	<b>Index .....</b>	<b>341</b>

## Fundamental safety instructions

### 1.1 General safety instructions



	<b>DANGER</b>
	<p><b>Danger to life due to live parts and other energy sources</b></p> <p>Death or serious injury can result when live parts are touched.</p> <ul style="list-style-type: none"> <li>• Only work on electrical devices when you are qualified for this job.</li> <li>• Always observe the country-specific safety rules.</li> </ul> <p>Generally, six steps apply when establishing safety:</p> <ol style="list-style-type: none"> <li>1. Prepare for shutdown and notify all those who will be affected by the procedure.</li> <li>2. Disconnect the machine from the supply. <ul style="list-style-type: none"> <li>– Switch off the machine.</li> <li>– Wait until the discharge time specified on the warning labels has elapsed.</li> <li>– Check that it really is in a no-voltage condition, from phase conductor to phase conductor and phase conductor to protective conductor.</li> <li>– Check whether the existing auxiliary supply circuits are de-energized.</li> <li>– Ensure that the motors cannot move.</li> </ul> </li> <li>3. Identify all other dangerous energy sources, e.g. compressed air, hydraulic systems, or water.</li> <li>4. Isolate or neutralize all hazardous energy sources by closing switches, grounding or short-circuiting or closing valves, for example.</li> <li>5. Secure the energy sources against switching on again.</li> <li>6. Ensure that the correct machine is completely interlocked.</li> </ol> <p>After you have completed the work, restore the operational readiness in the inverse sequence.</p>



	<b>WARNING</b>
	<p><b>Danger to life through a hazardous voltage when connecting an unsuitable power supply</b></p> <p>Touching live components can result in death or severe injury.</p> <ul style="list-style-type: none"> <li>• Only use power supplies that provide SELV (Safety Extra Low Voltage) or PELV- (Protective Extra Low Voltage) output voltages for all connections and terminals of the electronics modules.</li> </ul>



**! WARNING**

**Danger to life when live parts are touched on damaged devices**

Improper handling of devices can cause damage.

For damaged devices, hazardous voltages can be present at the enclosure or at exposed components; if touched, this can result in death or severe injury.

- Ensure compliance with the limit values specified in the technical data during transport, storage and operation.
- Do not use any damaged devices.



**! WARNING**

**Danger to life through electric shock due to unconnected cable shields**

Hazardous touch voltages can occur through capacitive cross-coupling due to unconnected cable shields.

- As a minimum, connect cable shields and the conductors of power cables that are not used (e.g. brake cores) at one end at the grounded housing potential.



**! WARNING**

**Danger to life due to electric shock when not grounded**

For missing or incorrectly implemented protective conductor connection for devices with protection class I, high voltages can be present at open, exposed parts, which when touched, can result in death or severe injury.

- Ground the device in compliance with the applicable regulations.



**! WARNING**

**Danger to life due to electric shock when opening plug connections in operation**

When opening plug connections in operation, arcs can result in severe injury or death.

- Only open plug connections when the equipment is in a no-voltage state, unless it has been explicitly stated that they can be opened in operation.

 **WARNING****Danger to life due to fire spreading if housing is inadequate**

Fire and smoke development can cause severe personal injury or material damage.

- Install devices without a protective housing in a metal control cabinet (or protect the device by another equivalent measure) in such a way that contact with fire is prevented.
- Ensure that smoke can only escape via controlled and monitored paths.

 **WARNING****Danger to life through unexpected movement of machines when using mobile wireless devices or mobile phones**

Using mobile wireless devices or mobile phones with a transmit power > 1 W closer than approx. 2 m to the components may cause the devices to malfunction, influence the functional safety of machines therefore putting people at risk or causing material damage.

- Switch the wireless devices or mobile phones off in the immediate vicinity of the components.

 **WARNING****Danger to life due to the motor catching fire in the event of insulation overload**

There is higher stress on the motor insulation through a ground fault in an IT system. If the insulation fails, it is possible that death or severe injury can occur as a result of smoke and fire.

- Use a monitoring device that signals an insulation fault.
- Correct the fault as quickly as possible so the motor insulation is not overloaded.

 **WARNING****Danger to life due to fire if overheating occurs because of insufficient ventilation clearances**

Inadequate ventilation clearances can cause overheating of components with subsequent fire and smoke. This can cause severe injury or even death. This can also result in increased downtime and reduced service lives for devices/systems.

- Ensure compliance with the specified minimum clearance as ventilation clearance for the respective component.

 **WARNING**

**Danger of an accident occurring due to missing or illegible warning labels**

Missing or illegible warning labels can result in accidents involving death or serious injury.

- Check that the warning labels are complete based on the documentation.
- Attach any missing warning labels to the components, in the national language if necessary.
- Replace illegible warning labels.

**NOTICE**

**Device damage caused by incorrect voltage/insulation tests**

Incorrect voltage/insulation tests can damage the device.

- Before carrying out a voltage/insulation check of the system/machine, disconnect the devices as all converters and motors have been subject to a high voltage test by the manufacturer, and therefore it is not necessary to perform an additional test within the system/machine.

 **WARNING**

**Danger to life when safety functions are inactive**

Safety functions that are inactive or that have not been adjusted accordingly can cause operational faults on machines that could lead to serious injury or death.

- Observe the information in the appropriate product documentation before commissioning.
- Carry out a safety inspection for functions relevant to safety on the entire system, including all safety-related components.
- Ensure that the safety functions used in your drives and automation tasks are adjusted and activated through appropriate parameterizing.
- Perform a function test.
- Only put your plant into live operation once you have guaranteed that the functions relevant to safety are running correctly.

**Note**

**Important safety notices for Safety Integrated functions**

If you want to use Safety Integrated functions, you must observe the safety notices in the Safety Integrated manuals.

## 1.2 Safety instructions for electromagnetic fields (EMF)



### ! WARNING

#### Danger to life from electromagnetic fields

Electromagnetic fields (EMF) are generated by the operation of electrical power equipment such as transformers, converters or motors.

People with pacemakers or implants are at a special risk in the immediate vicinity of these devices/systems.

- Ensure that the persons involved are the necessary distance away (minimum 2 m).

## 1.3 Handling electrostatic sensitive devices (ESD)

Electrostatic sensitive devices (ESD) are individual components, integrated circuits, modules or devices that may be damaged by either electric fields or electrostatic discharge.



### NOTICE

#### Damage through electric fields or electrostatic discharge

Electric fields or electrostatic discharge can cause malfunctions through damaged individual components, integrated circuits, modules or devices.

- Only pack, store, transport and send electronic components, modules or devices in their original packaging or in other suitable materials, e.g. conductive foam rubber or aluminum foil.
- Only touch components, modules and devices when you are grounded by one of the following methods:
  - Wearing an ESD wrist strap
  - Wearing ESD shoes or ESD grounding straps in ESD areas with conductive flooring
- Only place electronic components, modules or devices on conductive surfaces (table with ESD surface, conductive ESD foam, ESD packaging, ESD transport container).

## 1.4 Industrial security

### Note

#### Industrial security

Siemens provides products and solutions with industrial security functions that support the secure operation of plants, solutions, machines, equipment and/or networks. They are important components in a holistic industrial security concept. With this in mind, Siemens' products and solutions undergo continuous development. Siemens recommends strongly that you regularly check for product updates.

For the secure operation of Siemens products and solutions, it is necessary to take suitable preventive action (e.g. cell protection concept) and integrate each component into a holistic, state-of-the-art industrial security concept. Third-party products that may be in use should also be considered. For more information about industrial security, visit this address (<http://www.siemens.com/industrialsecurity>).

To stay informed about product updates as they occur, sign up for a product-specific newsletter. For more information, visit this address (<http://support.automation.siemens.com>).

### WARNING

#### **Danger as a result of unsafe operating states resulting from software manipulation**

Software manipulation (e.g. by viruses, Trojan horses, malware, worms) can cause unsafe operating states to develop in your installation which can result in death, severe injuries and/or material damage.

- Keep the software up to date.  
You will find relevant information and newsletters at this address (<http://support.automation.siemens.com>).
- Incorporate the automation and drive components into a holistic, state-of-the-art industrial security concept for the installation or machine.  
You will find further information at this address (<http://www.siemens.com/industrialsecurity>).
- Make sure that you include all installed products into the holistic industrial security concept.



## 1.5 Residual risks of power drive systems

The control and drive components of a drive system are approved for industrial and commercial use in industrial line supplies. Their use in public line supplies requires a different configuration and/or additional measures.

These components may only be operated in closed housings or in higher-level control cabinets with protective covers that are closed, and when all of the protective devices are used.

These components may only be handled by qualified and trained technical personnel who are knowledgeable and observe all of the safety instructions on the components and in the associated technical user documentation.

When assessing the machine's risk in accordance with the respective local regulations (e.g., EC Machinery Directive), the machine manufacturer must take into account the following residual risks emanating from the control and drive components of a drive system:

1. Unintentional movements of driven machine components during commissioning, operation, maintenance, and repairs caused by, for example,
  - Hardware and/or software errors in the sensors, control system, actuators, and cables and connections
  - Response times of the control system and of the drive
  - Operation and/or environmental conditions outside the specification
  - Condensation/conductive contamination
  - Parameterization, programming, cabling, and installation errors
  - Use of wireless devices/mobile phones in the immediate vicinity of the control system
  - External influences/damage
2. In the event of a fault, exceptionally high temperatures, including an open fire, as well as emissions of light, noise, particles, gases, etc. can occur inside and outside the inverter, e.g.:
  - Component failure
  - Software errors
  - Operation and/or environmental conditions outside the specification
  - External influences/damage

Inverters of the Open Type/IP20 degree of protection must be installed in a metal control cabinet (or protected by another equivalent measure) such that contact with fire inside and outside the inverter is not possible.

3. Hazardous shock voltages caused by, for example,
  - Component failure
  - Influence during electrostatic charging
  - Induction of voltages in moving motors
  - Operation and/or environmental conditions outside the specification
  - Condensation/conductive contamination
  - External influences/damage
4. Electrical, magnetic and electromagnetic fields generated in operation that can pose a risk to people with a pacemaker, implants or metal replacement joints, etc., if they are too close
5. Release of environmental pollutants or emissions as a result of improper operation of the system and/or failure to dispose of components safely and correctly

---

**Note**

The components must be protected against conductive contamination (e.g. by installing them in a control cabinet with degree of protection IP54 according to IEC 60529 or NEMA 12).

Assuming that conductive contamination at the installation site can definitely be excluded, a lower degree of cabinet protection may be permitted.

---

For more information about residual risks of the components in a drive system, see the relevant sections in the technical user documentation.

## System overview

### 2.1 Field of application

SINAMICS is the family of drives from Siemens designed for machine and plant engineering applications. SINAMICS offers solutions for all drive tasks:

- Simple pump and fan applications in the process industry.
- Complex single drives in centrifuges, presses, extruders, elevators, as well as conveyor and transport systems
- Drive line-ups in textile, plastic film, and paper machines as well as in rolling mill plants
- High-precision servo drives in the manufacture of wind turbines
- Highly dynamic servo drives for machine tools, as well as packaging and printing machines



Figure 2-1 SINAMICS applications

Depending on the application, the SINAMICS range offers the ideal variant for any drive task.

- SINAMICS G is designed for standard applications with induction motors. These applications have less stringent requirements regarding the dynamic performance of the motor speed.
- SINAMICS S handles complex drive tasks with synchronous/induction motors and fulfills stringent requirements regarding:
  - the dynamic performance and accuracy
  - the integration of extensive technological functions in the drive control system
- SINAMICS DC MASTER is the DC drive belonging to the SINAMICS family. As a result of its standard expandability, it addresses both basic as well as demanding drive applications and in complementary markets.

## 2.2 Platform Concept and Totally Integrated Automation

All SINAMICS versions are based on a platform concept. Joint hardware and software components, as well as standardized tools for design, configuration, and commissioning tasks ensure high-level integration across all components. SINAMICS handles a wide variety of drive tasks with no system gaps. The different SINAMICS versions can be easily combined with each other.

### Totally Integrated Automation (TIA) with SINAMICS S120

Apart from SIMATIC, SIMOTION and SINUMERIK, SINAMICS is one of the core components of TIA. The STARTER commissioning tool is an integral element of the TIA platform. It is thus possible to parameterize, program and commission all components in the automation system using a standardized engineering platform and without any gaps. The system-wide data management functions ensure consistent data and simplify archiving of the entire plant project.

SINAMICS S120 supports communication via PROFINET and PROFIBUS DP.

### Communication via PROFINET

This Ethernet-based bus enables control data to be exchanged at high speed via PROFINET IO with IRT or RT and makes SINAMICS S120 a suitable choice for integration in high-performance multi-axis applications. At the same time, PROFINET also uses standard IT mechanisms (TCP/IP) to transport information, e.g. operating and diagnostic data, to higher-level systems. This makes it easy to integrate into an IT corporate network.

### Communication via PROFIBUS DP

This bus provides a high-performance, system-wide and integrated communication network which links all automation components of the automation solution:

- HMI (operator control and monitoring)
- Control
- Drives and I/O

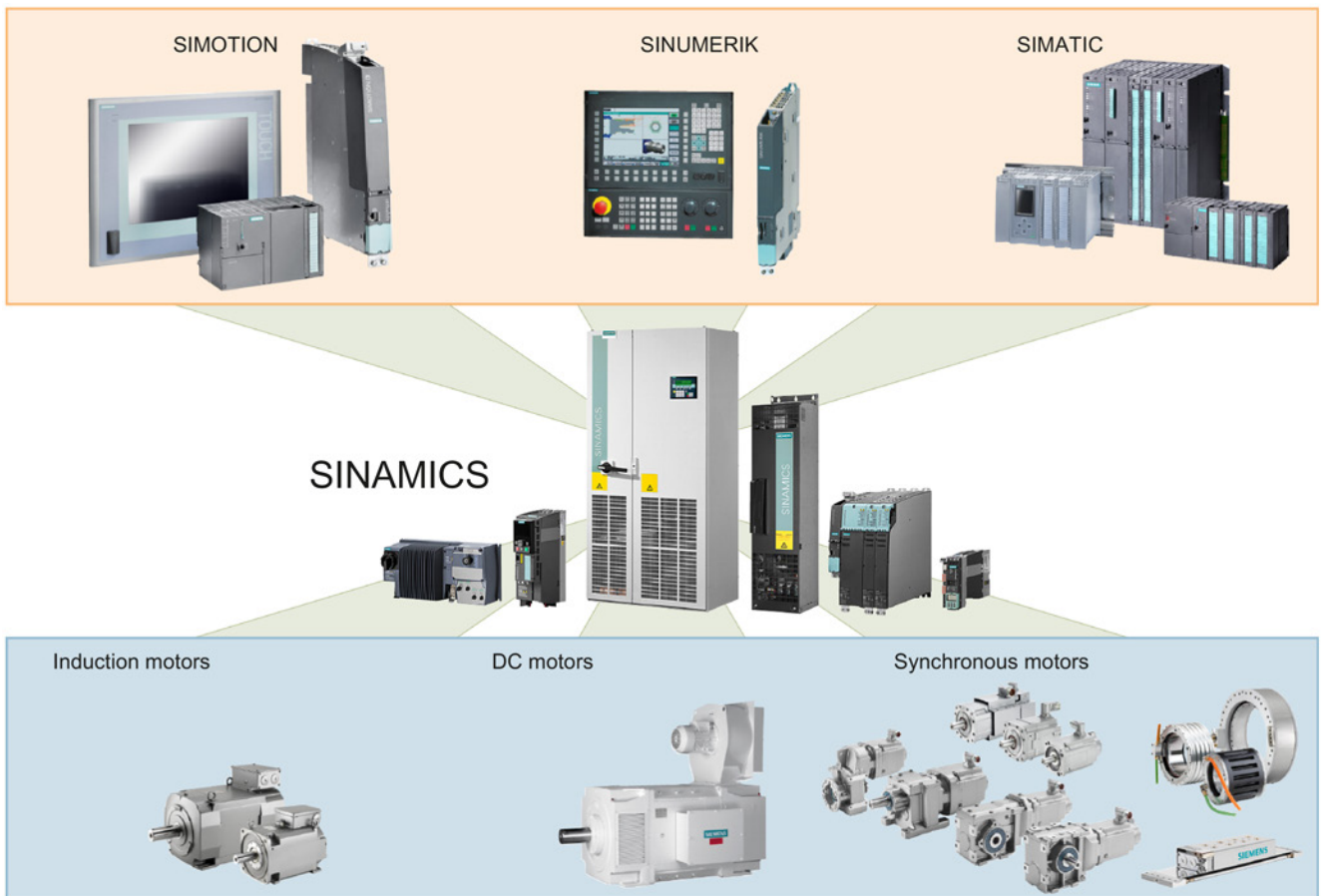

Figure 2-2 SINAMICS as part of the Siemens modular automation system

## 2.3 Introduction

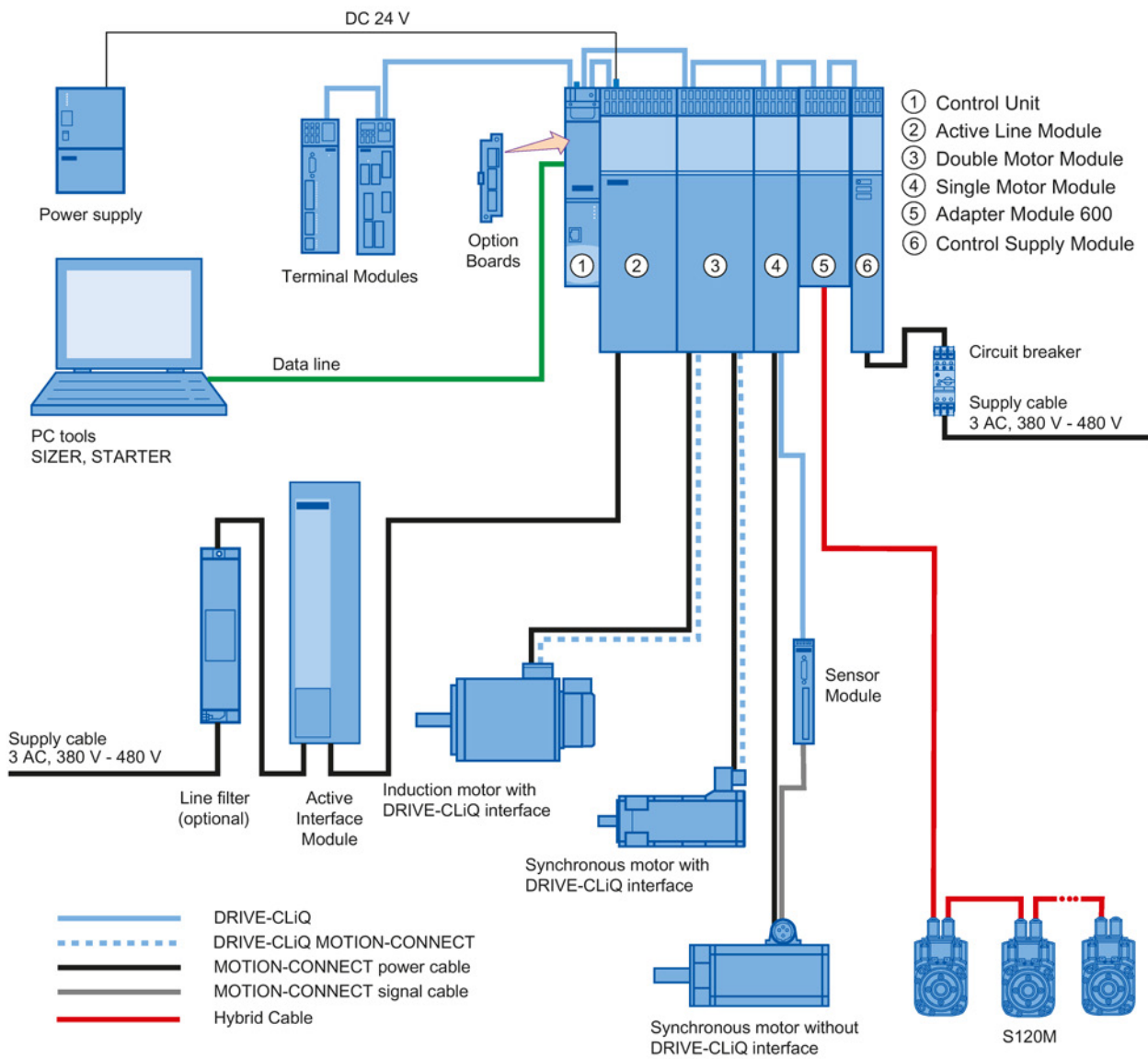

Figure 2-3 SINAMICS S120 system overview

### Modular system for sophisticated drive tasks

SINAMICS S120 solves complex drive tasks for a wide range of industrial applications and is, therefore, designed as a modular system. Users can choose from many different harmonized components and functions to create a solution that best meets their requirements. SIZER, a high-performance engineering tool, makes it easier to choose and determine the optimum drive configuration.

SINAMICS S120 is supplemented by a wide range of motors. Whether torque, synchronous or induction motors, whether rotating or linear motors, all of these motors are optimally supported by SINAMICS S120.

### **System architecture with a central Control Unit**

On the SINAMICS S120, the drive intelligence is combined with closed-loop control functions into Control Units. These units are capable of controlling drives in the vector, servo and V/f modes. They also perform the speed and torque control functions plus other intelligent drive functions for all axes on the drive. Inter-axis connections can be established within a component and easily configured in the STARTER commissioning tool using a mouse.

### **Functions for higher efficiency**

- Basic functions: Speed control, torque control, positioning functions
- Intelligent starting functions for independent restart after power supply interruption
- BICO technology with interconnection of drive-related I/Os for easy adaptation of the drive system to its operating environment
- Integrated safety functions for rational implementation of safety concepts
- Regulated infeed/regenerative feedback functions for preventing undesirable reactions on the supply, allowing recovery of braking energy and ensuring greater stability against line fluctuations.

### **DRIVE-CLiQ – the digital interface between SINAMICS components**

Most of the SINAMICS S120 components, including the motors and encoders, are connected to each other via the common DRIVE-CLiQ serial interface. The standardized cables and connectors reduce the variety of different parts and cut storage costs. Encoder evaluations for converting standard encoder signals to DRIVE-CLiQ are available for third-party motors or retrofit applications.

### **Electronic rating plates in all components**

An important digital linkage element of the SINAMICS S120 drive system are the electronic type plates integrated in every component. They allow all drive components to be detected automatically via a DRIVE-CLiQ link. As a result, data does not have to be entered manually during commissioning or component replacement – helping to ensure that drives are commissioned more reliably.

The rating plate contains all the relevant technical data about that particular component. For motors, these are the parameters of the electrical equivalent circuit diagram and key values of the integrated motor encoder, for example.

In addition to the technical data, the type plate includes logistical data (manufacturer ID, article number and ID). Since this data can be called up electronically on site or remotely, all the components used in a machine can always be individually identified, which helps simplify servicing.

## 2.4 SINAMICS S120 components

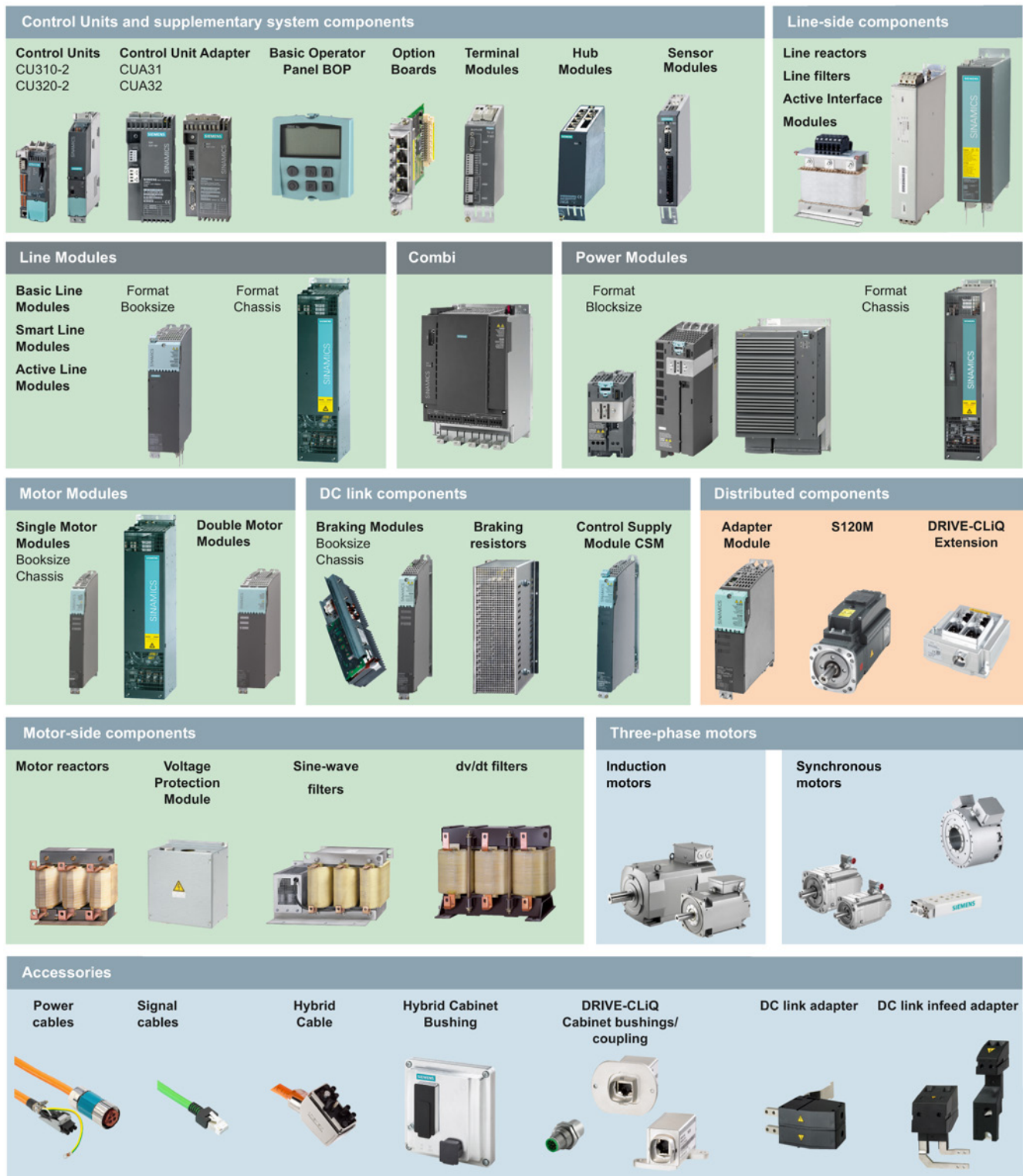

Figure 2-4 Overview of SINAMICS S120 components



### **System components**

- Line-side power components, such as fuses, contactors, reactors, and filters for switching the power supply and meeting EMC requirements.
- Line Modules, which supply power centrally to the DC link
- DC link components (optional), which stabilize the DC link voltage.
- Motor Modules, which act as inverters, receive power from the DC link, and supply the connected motors

To carry out the required functions, SINAMICS S120 is equipped with:

- Control Units that process the drive and technological functions across all axes
- Additional system components to expand the functionality and to handle various interfaces for encoders and process signals

SINAMICS S120 components are intended for installation in cabinets. They have the following features and characteristics:

- Easy to handle, simple installation and wiring
- Practical connection system, cable routing in accordance with EMC requirements
- Standardized design, side-by-side mounting

---

### **Note**

#### **Installation location in the cabinet**

The SINAMICS S120 components must always be mounted vertically in the cabinet. Other permissible installation locations are given in the descriptions for the individual components.

---

### **Booksize format**

Booksize format units are optimized for multi-axis applications and are mounted adjacent to one another. The connection for the shared voltage-source DC link is an integral feature.

The booksize format offers various cooling options:

- Internal air cooling
- External air cooling
- Cold plate cooling
- Liquid Cooled

### Booksized compact format

The booksized compact format combines all benefits of the booksized format and provides the same performance with an even smaller overall height. The booksized compact format is thus particularly well suited for integration into machines with high dynamic requirements and confined installation conditions.

The booksized compact format offers the following cooling options:

- Internal air cooling
- Cold plate cooling

## 2.5 Power units

### Line Modules

Generating a DC voltage for the DC link from the 3-phase line voltage.

- **Basic Line Modules**  
Basic Line Modules generate an uncontrolled DC link voltage and are not capable of energy recovery.
- **Smart Line Modules**  
Smart Line Modules generate an uncontrolled DC link voltage and are capable of energy recovery.
- **Active Line Modules**  
Active Line Modules generate a controlled DC link voltage and are capable of energy recovery.

### Motor Modules

Convert energy from the DC link for the connected motors with variable voltage and variable frequency.

## 2.6 System data

Unless explicitly specified otherwise, the following technical data are valid for components of the SINAMICS S120 booksize drive system.

Table 2- 1 Electrical data

Electronics power supply	24 VDC -15/+20% <sup>1)</sup> , protective extra low voltage PELV or SELV
Line connection voltage	380 ... 480 V 3 AC ±10 % (-15 % < 1 min)
Line frequency	47 ... 63 Hz
Radio interference suppression acc. to EN 61800-3	Category C3 (standard) Category C2 (option) for implementing plants and systems corresponding to the EC Declaration of Conformity for EMC and the Configuration Manual EMC Installation Guideline, Article No.: 6FC5297-xAD30-0APx
Overvoltage category	III acc. to EN 61800-5-1
Pollution degree	2 acc. to EN 61800-5 <sup>2)</sup>

- 1) The supply voltage may not fall below the minimum value of 20.4 V (24 V -15 %) at the last device in the line-up, as otherwise malfunctions can occur. The amplitude of the test current must be set adequately high for this. In order to prevent the maximum 24 V power supply voltage from being exceeded (= 28.8 V), the voltage can be injected at various locations in the line-up.
- 2) The components must be protected against conductive pollution, e.g. by installing them in a control cabinet with degree of protection IP54 according to IEC 60529 or NEMA 12. If conductive pollution can be excluded at the installation site, a lower degree of cabinet protection may be permitted.

Table 2- 2 Environmental conditions

Degree of protection	IPXXB acc. to EN 60529, open type according to UL 508
Degree of protection for SME20/25/120/125 and DME20	IP67, with mounted connectors or protective caps
Protection class, line supply circuits Electronic circuits	I with protective conductor connection according to EN 61800-5-1 protective extra low-voltage PELV / SELV
Permissible ambient temperature in the cabinet during operation	0 °C to +55 °C up to 2000 m above sea level. Above an altitude of 2000 m, the max. ambient temperature decreases by 3.5 °C every 500 m. Installation altitude: max. 4000 m above sea level
<b>Chemically active substances</b>	
Long-term storage in the transport packaging	Class 1C2 according to EN 60721-3-1
Transport in the transport packaging	Class 2C2 according to EN 60721-3-2
Operation	Class 3C2 according to EN 60721-3-3
<b>Biological environmental conditions</b>	
Long-term storage in the transport packaging	Class 1B1 according to EN 60721-3-1
Transport in the transport packaging	Class 2B1 according to EN 60721-3-2
Operation	Class 3B1 according to EN 60721-3-3

2.7 Recycling and disposal

<b>Vibratory load</b>	
Long-term storage in the transport packaging	Class 1M2 according to EN 60721-3-1
Transport in the transport packaging	Class 2M3 according to EN 60721-3-2
Operation (with the exception of SME20/25/120/125, DME20)	Class 3M2 according to EN 60721-3-3
Operation for SME20/25/120/125, DME20	Class 3M3 according to EN 60721-3-3
<b>Shock load</b>	
Long-term storage in the transport packaging	Class 1M2 according to EN 60721-3-1
Transport in the transport packaging	Class 2M3 according to EN 60721-3-2
Operation (with the exception of SME20/25/120/125, DME20)	Test values: 15 g / 11 ms
Operation for SME20/25/120/125, DME20	Test values: 25 g / 6 ms
<b>Climatic environmental conditions</b>	
Long-term storage in the transport packaging	Class 1K4 according to EN 60721-3-1 Temperature: -25°C ... +55°C
Transport in the transport packaging	Class 2K4 according to EN 60721-3-2 Temperature: -40°C ... +70°C
Operation (with the exception of SME20/25/120/125, DME20)	better than Class 3K3 according to EN 60721-3-3 Temperature: 0 ... +55 °C Relative humidity: 5 ... 95 % (no condensation) Oil mist, salt mist, ice formation, condensation, dripping water, spraying water, splashing water and water jets are not permitted
Operation for SME20/25/120/125, DME20	better than Class 3K3 according to EN 60721-3-3 Temperature: 0 ... +55 °C Relative humidity: 5 ... 95 % (no condensation) Formation of ice and condensation not permissible

Table 2- 3 Certificates

Declarations of Conformity	CE
Approvals	cULus

## 2.7 Recycling and disposal

Dispose of the product according to the applicable national regulations.

The products described in this Equipment Manual are extensively recyclable on account of the low-toxic composition of the materials used. To recycle and dispose of your old device in an environmentally friendly way, please contact a company that disposes of electronic waste.

# Control Units and operating elements

## 3.1 Introduction

### Description

Control Units CU320-2 PN and CU320-2 DP of the SINAMICS S system are designed for use with several drives.

The number of variable-speed drives depends on:

- The required performance
- The required additional functions
- The required operating mode (servo, vector or U/f)

The software and the parameters are stored on a plug-in memory card.

The option slot is used to expand the number of terminals or adapt to other communication interfaces (to the higher-level control).

#### **Compatible firmware versions:**

- CU320-2 PN V4.4 or higher
- CU320-2 DP V4.3 or higher

3.1 Introduction

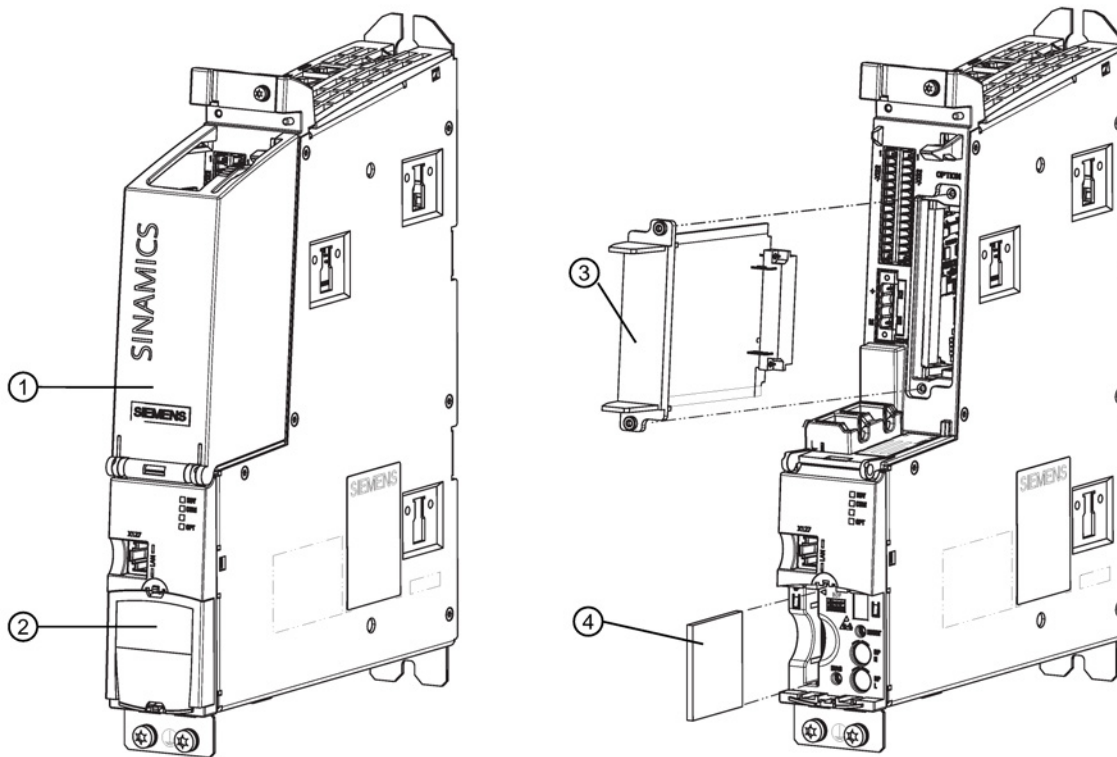

- ① Cover
- ② Blanking cover
- ③ Option Board (optional)
- ④ Memory card

Figure 3-1 Overview, Control Unit CU320-2 PN

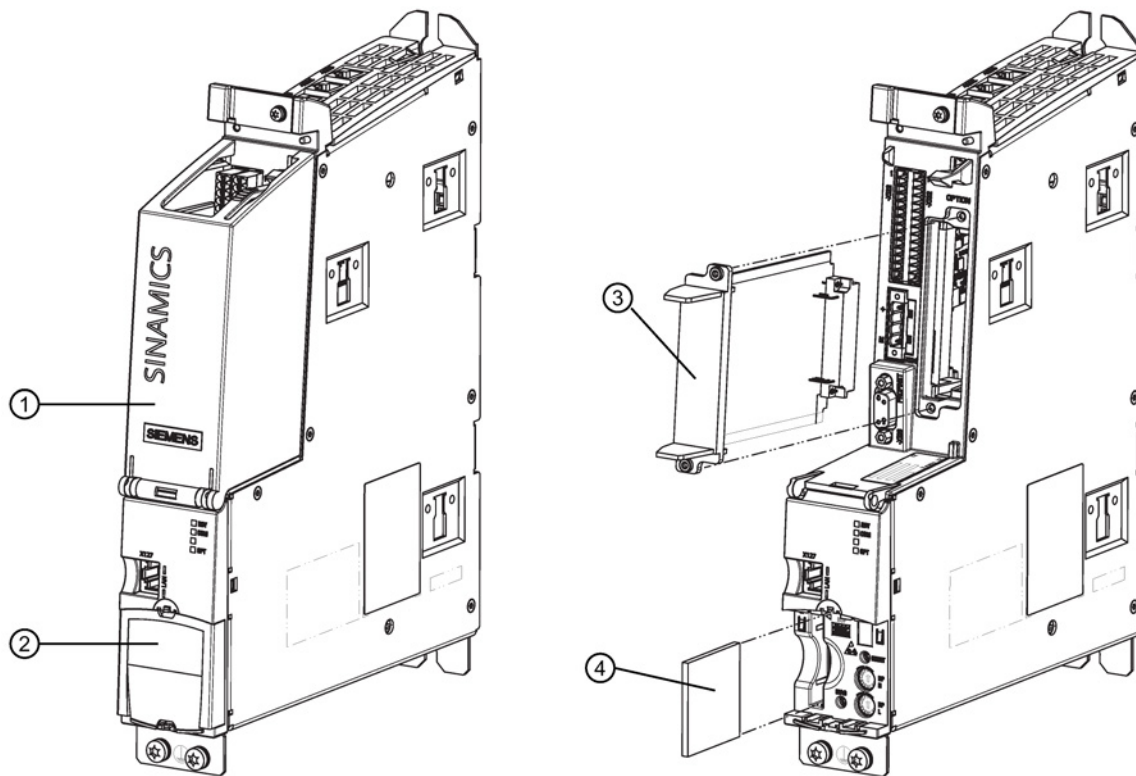

- ① Cover
- ② Blanking cover
- ③ Option Board (optional)
- ④ Memory card

Figure 3-2 Overview, Control Unit CU320-2 DP

### Note

The Control Unit, the option board, and the memory card must be ordered separately.

If your application requires more than one Control Unit, the number can be increased accordingly. The Control Units are then interconnected via PROFIBUS, for example.

A Control Unit communicates with the associated components (Motor Modules, Line Modules, Sensor Modules, Terminal Modules, and so on) via the system-internal DRIVE-CLiQ interface.

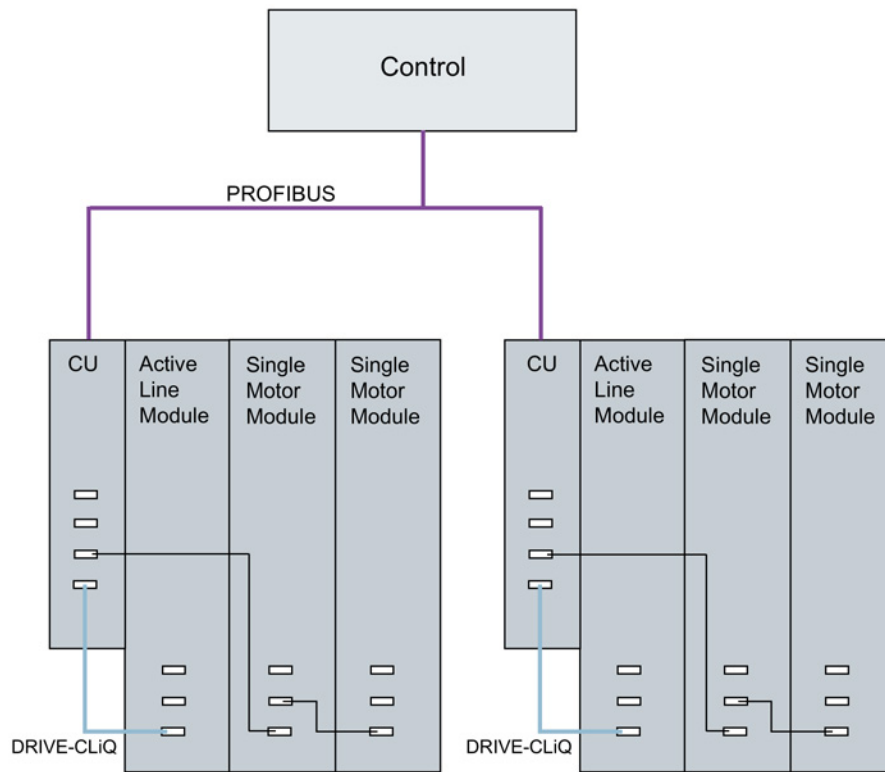

Figure 3-3 Sample configuration

## 3.2 Safety instructions for Control Units

<p><b>⚠ WARNING</b></p> <p><b>Danger to life if the fundamental safety instructions and remaining risks are not carefully observed</b></p> <p>If the fundamental safety instructions and remaining risks in Chapter 1 (Page 19) are not observed, accidents involving severe injuries or death may occur.</p> <ul style="list-style-type: none"> <li>• Adhere to the fundamental safety instructions.</li> <li>• When assessing the risk, take into account remaining risks.</li> </ul>
<p><b>⚠ WARNING</b></p> <p><b>Risk of fire through overheating if there are insufficient ventilation clearances</b></p> <p>Insufficient ventilation clearances lead to overheating with associated risk to persons as a result of smoke and fire. This can also result in more downtimes and a reduced service life for the Control Unit.</p> <ul style="list-style-type: none"> <li>• For this reason, it is imperative that you maintain the 80 mm clearances above and below the Control Unit.</li> </ul>



---

**NOTICE**

**Risk of destroying components resulting from high discharge currents**

The Control Unit or other PROFIBUS and/or PROFINET nodes can be destroyed, if significant discharge currents flow via the PROFIBUS or PROFINET cable.

- A functional equipotential bonding conductor with a cross-section of at least 25 mm<sup>2</sup> must be used between components in a system that are located at a distance from each other.

**NOTICE**

**Malfunctions or damage to the option board by inserting and withdrawing in operation**

Withdrawing and inserting the option board in operation can damage it or cause it to malfunction.

- Only withdraw or insert the Option Board when the Control Unit is current-free.

**NOTICE**

**Damage through use of incorrect DRIVE-CLiQ cables**

Damage or malfunctions can occur on the devices or system when incorrect or unreleased DRIVE-CLiQ cables are used.

- Only use suitable DRIVE-CLiQ cables that have been released by Siemens for the respective application.

---

**Note**

**Malfunctions due to polluted DRIVE-CLiQ interfaces**

Malfunctions can occur in the system through the use of polluted DRIVE-CLiQ interfaces.

- Cover unused DRIVE-CLiQ interfaces with the supplied blanking covers.

---

**Note**

**Function equipotential bonding for distributed DRIVE-CLiQ nodes**

Integrate all of the components that are connected via DRIVE-CLiQ in the functional equipotential bonding concept. The connection should be preferably established by mounting on metallic bare machine and plant components that are connected with one another using an equipotential bonding conductor.

Alternatively, you can establish equipotential bonding using a conductor (min. 6 mm<sup>2</sup>), which as far as possible, is routed in parallel to the DRIVE-CLiQ cable. All distributed DRIVE-CLiQ devices, such as DMx20, SME2x, SME12x etc., are involved.

---

### 3.3 Control Unit CU320-2 PN (PROFINET)

#### 3.3.1 Description

The Control Unit CU320-2 PN is a central control module in which the closed-loop and open-loop functions are implemented for one or more Line Modules and/or Motor Modules. It can be used with firmware version 4.4 or higher.

The CU320-2 PN has the following interfaces (ports):

Table 3- 1 Overview of the CU320-2 PN interfaces

Type	Quantity
Isolated digital inputs	12
Non-isolated digital inputs/outputs	8
DRIVE-CLiQ interfaces	4
PROFINET interfaces	2
LAN (Ethernet)	1
Serial interface (RS232)	1
Option slot	1
Measuring terminals	3

### 3.3.2 Interface description

#### 3.3.2.1 Overview

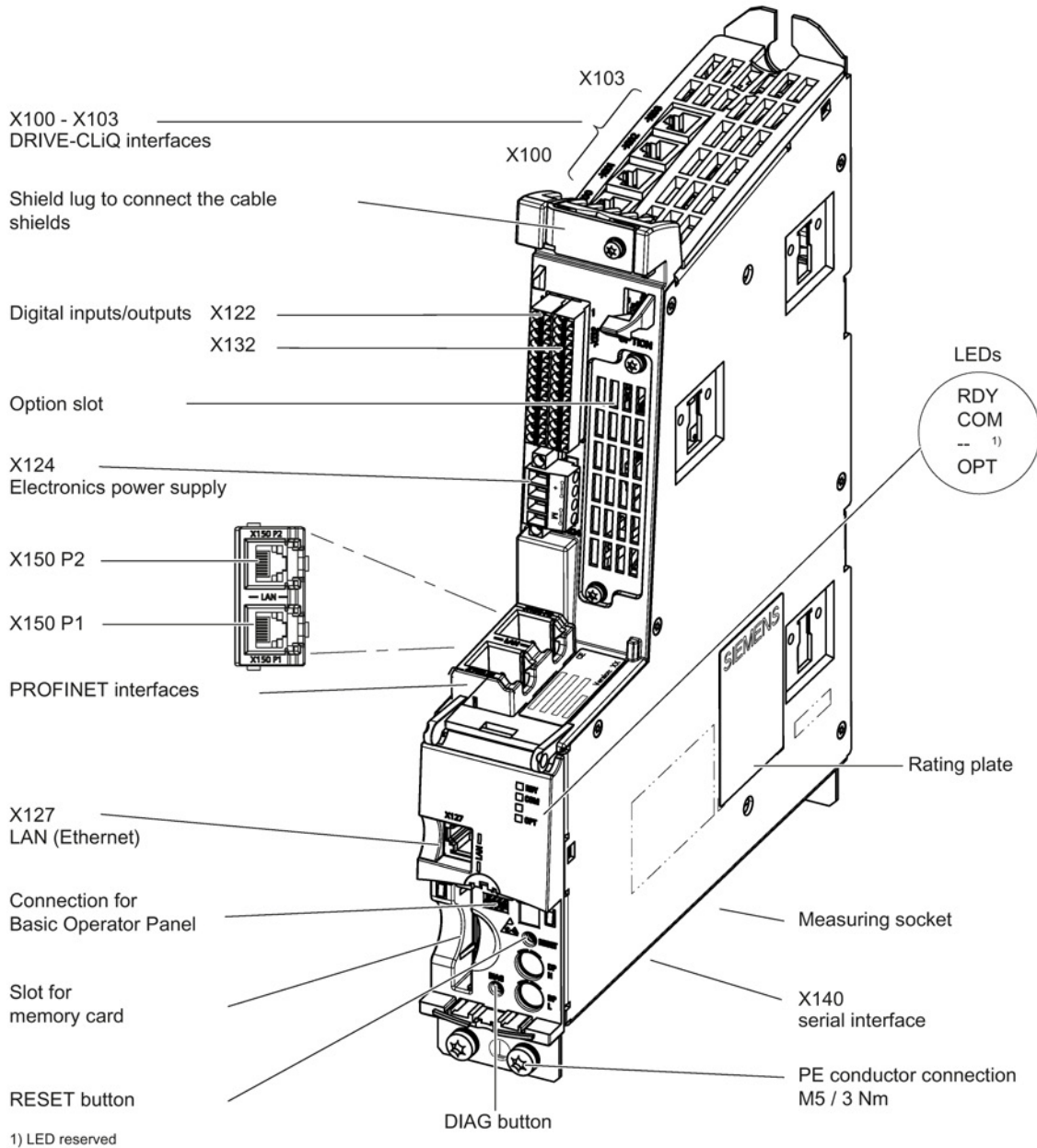

Figure 3-4 Interface overview CU320-2 PN (without cover and blanking cover)

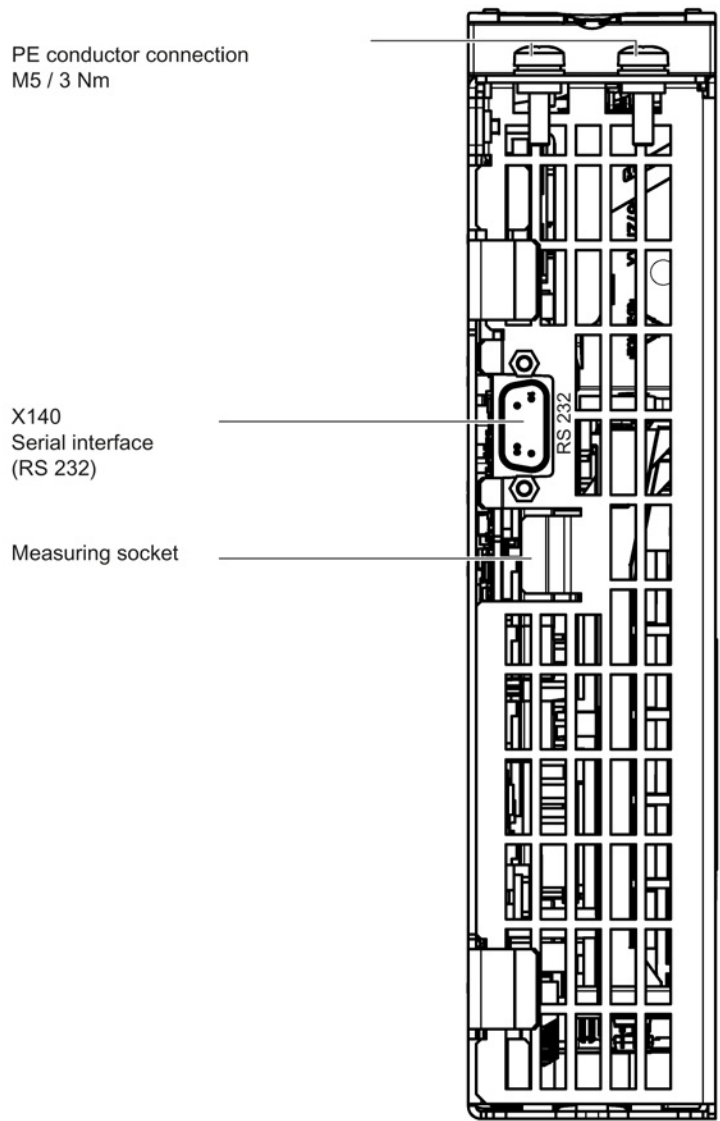

Figure 3-5 Interface X140 and measuring socket - CU320-2 PN (view from below)

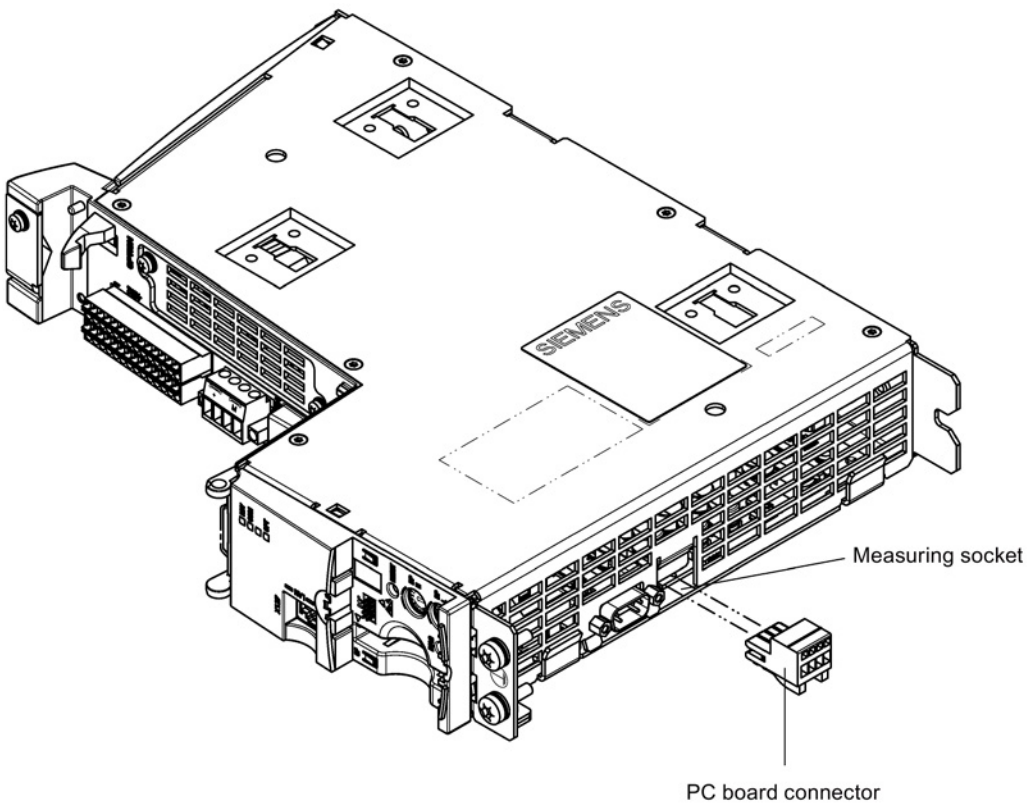

Figure 3-6 Mounting a PC board connector (Phoenix Contact) in the measuring socket

### 3.3.2.2 X100-X103 DRIVE-CLiQ interfaces

Table 3- 2 X100-X103 DRIVE-CLiQ interfaces

	Pin	Signal name	Technical data
	1	TXP	Transmit data +
	2	TXN	Transmit data -
	3	RXP	Receive data +
	4	Reserved, do not use	
	5	Reserved, do not use	
	6	RXN	Receive data -
	7	Reserved, do not use	
	8	Reserved, do not use	
	A	+ (24 V)	Power supply
	B	M (0 V)	Electronics ground
Connector type	DRIVE-CLiQ socket		

The blanking covers for the DRIVE-CLiQ interfaces are included in the scope of delivery.  
 Blanking covers (50 x) Article No.: 6SL3066-4CA00-0AA0

3.3.2.3 X122 digital inputs/outputs

Table 3- 3 X122 digital inputs/outputs

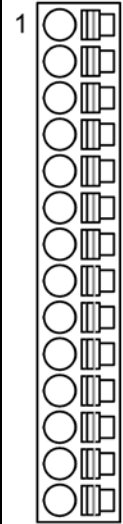
	Terminal	Designation <sup>1)</sup>	Technical data
	1	DI 0	Voltage (max.): -3 ... +30 V DC Current consumption, typical: 9 mA at 24 V Electrical isolation: The reference potential is terminal M1 Signal level (incl. ripple) High level: 15 ... 30 V Low level: -3 ... +5 V Input delay (typ.): For "0" → "1": 50 µs For "1" → "0": 150 µs
	2	DI 1	
	3	DI 2	
	4	DI 3	
	5	DI 16	
	6	DI 17	
	7	M1	Reference potential for terminals 1 ... 6
	8	M	Electronics ground
	9	DI/DO 8	<b>As input:</b> Voltage: -3 ... +30 V DC Current consumption, typical: 9 mA at 24 V Signal level (incl. ripple) High level: 15 ... 30 V Low level: -3 ... +5 V DI/DO 8, 9, 10, and 11 are "rapid inputs" <sup>2)</sup> Input delay (typ.) For "0" → "1": 5 µs For "1" → "0": 50 µs <b>As output:</b> Voltage: 24 V DC Max. load current per output: 500 mA Continuous short-circuit proof Output delay (typ./max): <sup>3)</sup> For "0" → "1": 150 µs / 400 µs For "1" → "0": 75 µs / 100 µs Switching frequency: For resistive load: Max. 100 Hz For inductive load: Max. 0.5 Hz For lamp load: Max. 10 Hz Maximum lamp load: 5 W
	10	DI/DO 9	
	11	M	
	12	DI/DO 10	
	13	DI/DO 11	
	14	M	

Type: Spring-loaded terminal 3 (Page 336)  
 Max. cross-section that can be connected: 1.5 mm<sup>2</sup>

1) DI: digital input; DI/DO: bidirectional digital input/output; M: electronics ground; M1: reference potential  
 2) The rapid inputs can be used as probe inputs or as inputs for the external zero mark.  
 3) Data for: V<sub>cc</sub> = 24 V; load 48 Ω; high ("1") = 90% V<sub>out</sub>; low ("0") = 10% V<sub>out</sub>

The maximum cable length that can be connected is 30 m.

---

**Note**

**Ensuring the function of digital inputs**

An open input is interpreted as "low".

Terminal M1 must be connected so that the digital inputs (DI) can function.

This is achieved by using one of the following measures:

1. Providing the ground reference of the digital inputs
2. A jumper to terminal M

**Note:** This removes isolation for these digital inputs.

---

**Note**

If the 24 V supply is briefly interrupted, then the digital outputs are deactivated during this time.

---

3.3.2.4 X132 digital inputs/outputs

Table 3- 4 X132 digital inputs/outputs

	Terminal	Designation <sup>1)</sup>	Technical data
	1	DI 4	Voltage (max.): -3 ... +30 V DC Current consumption, typical: 9 mA at 24 V Electrical isolation: The reference potential is terminal M2 Signal level (including ripple) High level: 15 ... 30 V Low level: -3 ... +5 V Input delay (typ.): For "0" → "1": 50 µs For "1" → "0": 150 µs
	2	DI 5	
	3	DI 6	
	4	DI 7	
	5	DI 20	
	6	DI 21	
	7	M2	Reference potential for terminals 1 ... 6
	8	M	Electronics ground
	9	DI/DO 12	<b>As input:</b> Voltage: -3 ... +30 V DC Current consumption, typical: 9 mA at 24 V Signal level (including ripple) High level: 15 ... 30 V Low level: -3 ... +5 V DI/DO 12, 13, 14, and 15 are "rapid inputs" <sup>2)</sup> Input delay (typ.): For "0" → "1": 5 µs For "1" → "0": 50 µs <b>As output:</b> Voltage: 24 V DC Max. load current per output: 500 mA Continuous short-circuit proof Output delay (typ./max): <sup>3)</sup> For "0" → "1": 150 µs / 400 µs For "1" → "0": 75 µs / 100 µs Switching frequency: For resistive load: Max. 100 Hz For inductive load: Max. 0.5 Hz For lamp load: Max. 10 Hz Maximum lamp load: 5 W
	10	DI/DO 13	
	11	M	
	12	DI/DO 14	
	13	DI/DO 15	
	14	M	
Type: Spring-loaded terminal 3 (Page 336) Max. cross-section that can be connected: 1.5 mm <sup>2</sup>			

1) DI: digital input; DI/DO: bidirectional digital input/output; M: electronics ground; M2: reference potential

2) The rapid inputs can be used as probe inputs or as inputs for the external zero mark

3) Data for: V<sub>cc</sub> = 24 V; load 48 Ω; high ("1") = 90% V<sub>out</sub>; low ("0") = 10% V<sub>out</sub>

The maximum cable length that can be connected is 30 m.



**Note**

**Ensuring the function of digital inputs**

An open input is interpreted as "low".

To enable the digital inputs (DI) to function, terminal M2 must be connected.

This is achieved by using one of the following measures:

1. Providing the ground reference of the digital inputs
2. A jumper to terminal M

**Note:** This removes isolation for these digital inputs.

**Note**

If the 24 V supply is briefly interrupted, then the digital outputs are deactivated during this time.

**3.3.2.5 X124 electronics power supply**

Table 3- 5 X124 electronics power supply

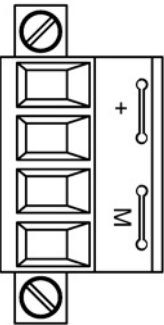
	Terminal	Designation	Technical data
	+	Electronics power supply	Voltage: 24 V DC (20.4 ... 28.8 V) Current consumption: max. 1.0 A (without DRIVE-CLiQ or digital outputs) Max. current through the jumper in the connector: 20 A (15 A according to UL/CSA)
	+	Electronics power supply	
	M	Electronics ground	
	M	Electronics ground	
Type: Screw terminal 2 (Page 336)			

The maximum cable length that can be connected is 30 m.

**Note**

The two "+" or "M" terminals are jumpered in the connector. This ensures that the supply voltage is looped through.

The current consumption increases by the value for the DRIVE-CLiQ node and digital outputs.

**Note**

The terminal block must be screwed on tightly using a flat-bladed screwdriver.

**3.3.2.6 X127 LAN (Ethernet)**

Table 3- 6 X127 LAN (Ethernet)

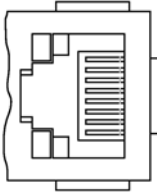
	Pin	Signal name	Technical data
	1	TXP	Ethernet transmit data +
	2	TXN	Ethernet transmit data -
	3	RXP	Ethernet receive data +
	4	Reserved, do not use	
	5	Reserved, do not use	
	6	RXN	Ethernet receive data -
	7	Reserved, do not use	
	8	Reserved, do not use	
Connector type: RJ45 socket			

**Note**

The LAN (Ethernet) interface does not support Auto MDI(X). For this reason, only crossed cables may be used to connect devices.

For diagnostic purposes, the X127 LAN interface features a green and a yellow LED. These LEDs indicate the following status information:

Table 3- 7 LED statuses for the X127 LAN interface

LED	Color	Status	Description
Link port	-	Off	Missing or faulty link
	Green	Continuous light	10 or 100 Mbit link available
Activity port	-	Off	No activity
	Yellow	Flashing light	Sending or receiving

### 3.3.2.7 X140 serial interface (RS232)

An external display and operator device for operator control/parameterization can be connected via the serial interface. The interface is located on the lower side of the Control Unit.

Table 3- 8 X140 serial interface (RS232)

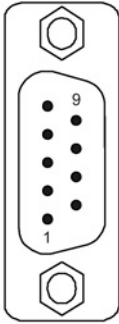
	Pin	Signal name	Technical data
	1	Reserved, do not use	
	2	RxD	Receive data
	3	TxD	Transmit data
	4	Reserved, do not use	
	5	Ground	Ground reference
	6	Reserved, do not use	
	7	Reserved, do not use	
	8	Reserved, do not use	
	9	Reserved, do not use	
Connector type: 9-pin SUB D connector			

### 3.3.2.8 X150 P1/P2 PROFINET

The PROFINET interfaces can be operated isochronously.

Table 3- 9 X150 P1 and X150 P2 PROFINET

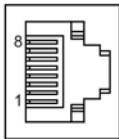
	Pin	Signal name	Technical data
	1	RXP	Receive data +
	2	RXN	Receive data -
	3	TXP	Transmit data +
	4	Reserved, do not use	
	5	Reserved, do not use	
	6	TXN	Transmit data -
	7	Reserved, do not use	
	8	Reserved, do not use	
Connector type: RJ45 socket Cable type: PROFINET			

#### Note

The PROFINET interfaces support Auto MDI(X). It is therefore possible to use both crossed and uncrossed cables to connect the devices.

For diagnostic purposes, the two PROFINET interfaces are equipped with a green and a yellow LED. These LEDs indicate the following status information:

Table 3- 10 LED states at the X150 P1/P2 PROFINET interface

LED	Color	Status	Description
Link port	-	Off	Missing or faulty link
	Green	Continuous light	10 or 100 Mbit link available
Activity port	-	Off	No activity
	Yellow	Flashing light	Data is being received or sent at port x

### 3.3.2.9 Measuring socket

Table 3- 11 Measuring socket with mounted PC board connector

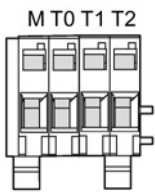
	Socket	Function	Technical data
	M	Ground	Voltage: 0... 5 V Resolution: 8 bits Load current: max. 3 mA Continuous short-circuit proof The reference potential is terminal M
	T0	Measuring terminal 0	
	T1	Measuring terminal 1	
	T2	Measuring terminal 2	
PC board connector, Phoenix Contact, type: ZEC 1.0/ 4-ST-3.5 C1 R1.4, Article number: 1893708			

**Note**

**Cable cross section**

The measuring terminals are only suitable for conductor cross-sections of 0.2 mm<sup>2</sup> up to 1 mm<sup>2</sup>.

**Note**

**Use of the measuring socket**

The measuring socket supports commissioning and diagnostic functions. It must not be connected for normal operation.

### 3.3.2.10 Buttons

**RESET button**

Pressing the RESET button restarts the device, just the same as after connecting the electronics power supply (cold restart).

**DIAG button**

The DIAG pushbutton is reserved for service functions.

### 3.3.2.11 Slot for memory card



Figure 3-7 Slot for memory card

**! WARNING**

**Danger to life due to software manipulation when using exchangeable storage media**

The storage of files on removable storage media involves a high risk of infection, e.g. via viruses or malware. As a result of incorrect parameterization, machines can malfunction, which in turn can lead to injuries or death.

- Protect the files on removable storage media against malware through appropriate protective measures, e.g. virus scanners.

**Note**

**Possible plant standstill by withdrawing or inserting the memory card in operation**

If the memory card is withdrawn or inserted during operation, then data can be lost, possibly resulting in a plant standstill.

- Only withdraw and insert the memory card when the Control Unit is in a no-voltage condition.

---

**Note**

**Insertion direction for the memory card**

Only insert the memory card as shown in the photo above (arrow at top right).

---



**NOTICE**

**Memory card damage caused by electric fields or electrostatic discharge**

Electric fields or electrostatic discharge may result in the memory card being damaged.

- When removing and inserting the memory card, always observe the ESD regulations (Page 23).

---

**Note**

**Possible data loss when returning the Control Unit with memory card**

When returning a defective Control Unit for repair or testing, the data on the memory card (parameters, firmware, licenses, etc.) could be lost.

- Do not return the memory card as well, but keep it in a safe place so that it can be inserted in the replacement unit.
- 

**Note**

Please note that only SIEMENS memory cards can be used to operate the Control Unit.

---

### 3.3.3 Connection example

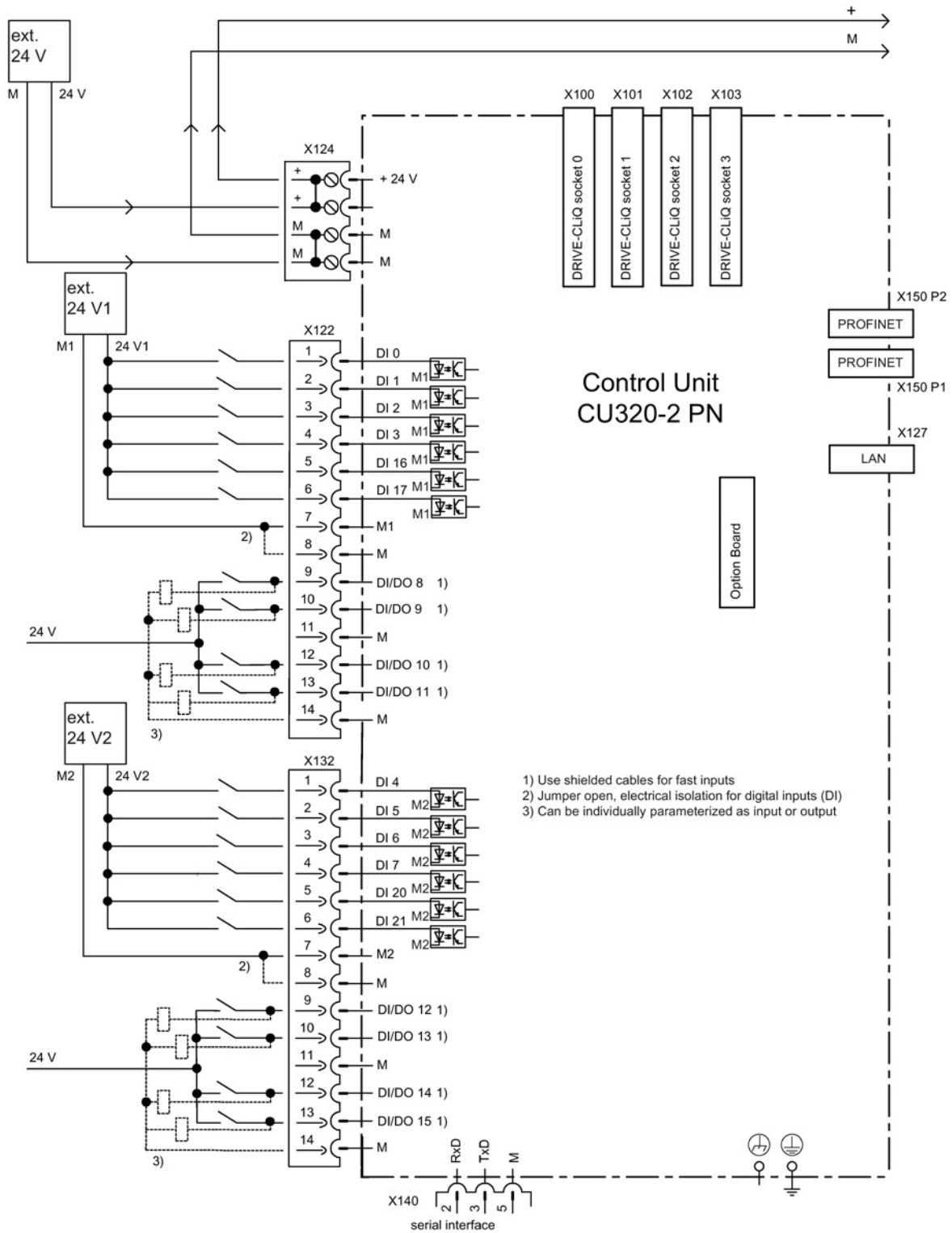

Figure 3-8 Connection example of a Control Unit CU320-2 PN

### 3.3.4 Meaning of the LEDs

#### 3.3.4.1 Description of the LED statuses

The different statuses that arise during the booting procedure are indicated by means of the LEDs on the Control Unit.

- The duration of the individual statuses varies.
- If an error occurs, the booting procedure is terminated and the cause is indicated accordingly via the LEDs.
- Once the unit has successfully booted up, all the LEDs are switched off briefly.
- Once the unit has booted up, the LEDs are controlled via the loaded software.

#### 3.3.4.2 Behavior of the LEDs during booting

Table 3- 12 Load software

LED			Status	Comment
RDY	COM	OPT		
Red	Orange	Orange	Reset	Hardware reset RDY LED lights up red, all other LEDs light up orange
Red	Red	Off	BIOS loaded	–
Red flash- ing light 2 Hz	Red	Off	BIOS error	<ul style="list-style-type: none"> <li>• Error occurred while loading the BIOS</li> </ul>
Red flash- ing light 2 Hz	Red flash- ing light 2 Hz	Off	File error	<ul style="list-style-type: none"> <li>• Memory card not inserted or defective</li> <li>• Software on memory card not present or corrupted</li> </ul>
Red	Orange flashing light	Off	FW loading	RDY LED lights up red, COM LED flashes orange without fixed frequency
Red	Off	Off	FW loaded	–
Off	Red	Off	FW checked (no CRC error)	–
Red flash- ing light 0.5 Hz	Red flash- ing light 0.5 Hz	Off	FW checked (CRC error)	<ul style="list-style-type: none"> <li>• CRC invalid</li> </ul>

Table 3- 13 Firmware

LED			Status	Comment
RDY	COM	OPT		
Orange	Off	Off	Initializing	–
Alternating			Running	See the table below



### 3.3.4.3 Behavior of the LEDs in the operating state

Table 3- 14 Control Unit CU320-2 PN – Description of the LEDs after booting

LED	Color	Status	Description, cause	Remedy
RDY (READY)	–	OFF	Electronics power supply is missing or outside the permissible tolerance range.	Check power supply
	Green	Continuous light	The component is ready for operation and cyclic DRIVE-CLiQ communication is taking place.	–
		Flashing light 0.5 Hz	Commissioning/reset	–
		Flashing light 2 Hz	Writing to the memory card	–
	Red	Flashing light 2 Hz	General error	Check parameterization / configuration
	Red/ green	Flashing light 0.5 Hz	Control Unit is ready for operation. However, there are no software licenses.	Obtain licenses
	Orange	Flashing light 0.5 Hz	Updating the firmware of the DRIVE-CLiQ components	–
		Flashing light 2 Hz	DRIVE-CLiQ component firmware update complete. Wait for POWER ON for the components in question.	Turn POWER ON for the components in question
	Green/ orange or red/ orange	Flashing light 2 Hz	Component recognition via LED is activated. <b>Note:</b> Both options depend on the LED status when component recognition is activated.	–
COM PROFIdrive cyclic operation	–	Off	Cyclic communication has not (yet) taken place. <b>Note:</b> PROFIdrive is ready for communication when the Control Unit is ready (see LED RDY).	–
	Green	Continuous light	Cyclic communication is taking place.	–
		Flashing light 0.5 Hz	Full cyclic communication has not yet taken place. Possible causes: <ul style="list-style-type: none"> <li>• The controller is not transferring any set-points.</li> <li>• During isochronous operation, no global control (GC) or a faulty global control (GC) is transferred by the controller.</li> <li>• "Shared Device" is selected and only one controller connected.</li> </ul>	–
	Red	Flashing light 0.5 Hz	Bus error, incorrect parameter assignment/configuration	Adapt configuration between controller and devices
		Flashing light 2 Hz	Cyclic bus communication has been interrupted or could not be established	Remove fault

3.3 Control Unit CU320-2 PN (PROFINET)

LED	Color	Status	Description, cause	Remedy
OPT (OPTION)	-	Off	Electronics power supply is missing or outside the permissible tolerance range. Component is not ready. Option board not installed or no associated drive object has been created.	Check power supply and/or component
	Green	Continuous light	Option board is ready.	-
		Flashing light 0.5 Hz	Depends on the Option Board used.	-
	Red	Flashing light 2 Hz	This component has at least one fault. The Option Board is not ready (e.g. after switching on).	Remove the fault and acknowledge
RDY and COM	Red	Flashing light 2 Hz	Bus error - communication has been interrupted	Remove fault
RDY and OPT	Orange	Flashing light 0.5 Hz	The firmware of the connected option board is being updated.	-

3.3.5 Dimension drawing

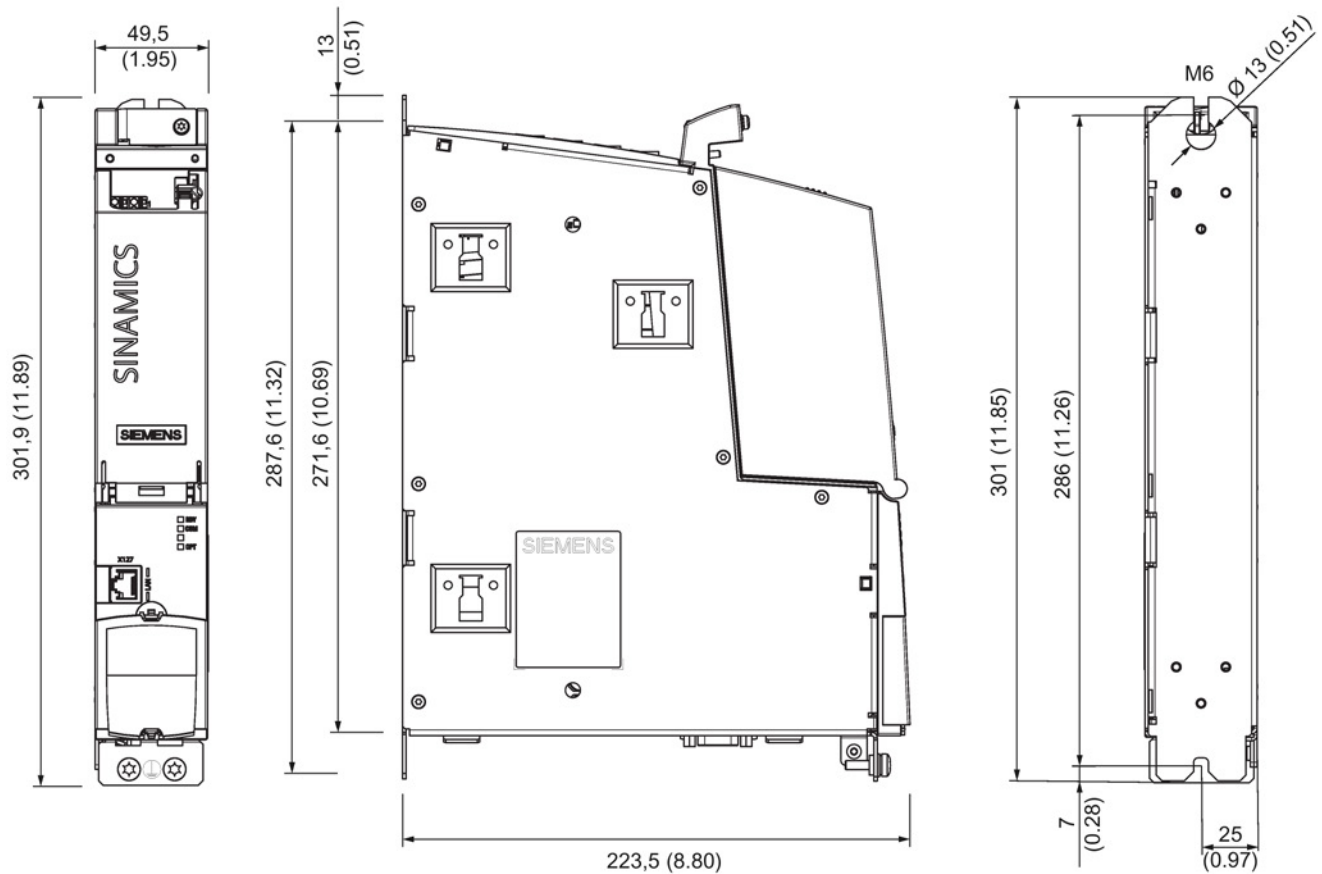

Figure 3-9 Dimension drawing of CU320-2 PN, all data in mm and (inches)

### 3.3.6 Technical data

Table 3- 15 Technical data

6SL3040-1MA01-0AA0	Unit	Value
Electronics power supply		
Voltage	V <sub>DC</sub>	24 (20.4 ... 28.8)
Current (without DRIVE-CLiQ and digital outputs)	A <sub>DC</sub>	1.0
Power loss	W	24
Total maximum permissible output currents	A	5.5
Maximum DRIVE-CLiQ cable length	m	100
PE/ground connection	On the housing with M5/3 Nm screw	
Response time	The response time of digital inputs/outputs depends on the evaluation (refer to the function diagram). Additional information can be taken from the following references: Reference: /LH1/ SINAMICS S120/S150 List Manual, Chapter "Function diagrams/CU320-2 Input/Output terminals"	
Weight	kg	2.3

## 3.4 Control Unit CU320-2 DP (PROFIBUS)

### 3.4.1 Description

The Control Unit CU320-2 DP is a central control module in which the closed-loop and open-loop functions are implemented for one or more Line Modules and/or Motor Modules. It can be used with firmware version 4.3 or higher.

The CU320-2 DP has the following interfaces (ports):

Table 3- 16 Overview of the CU320-2 DP interfaces

Type	Quantity
Isolated digital inputs	12
Non-isolated digital inputs/outputs	8
DRIVE-CLiQ interfaces	4
PROFIBUS interface	1
LAN (Ethernet)	1
Serial interface (RS232)	1
Option slot	1
Measuring terminals	3

### 3.4.2 Interface description

#### 3.4.2.1 Overview

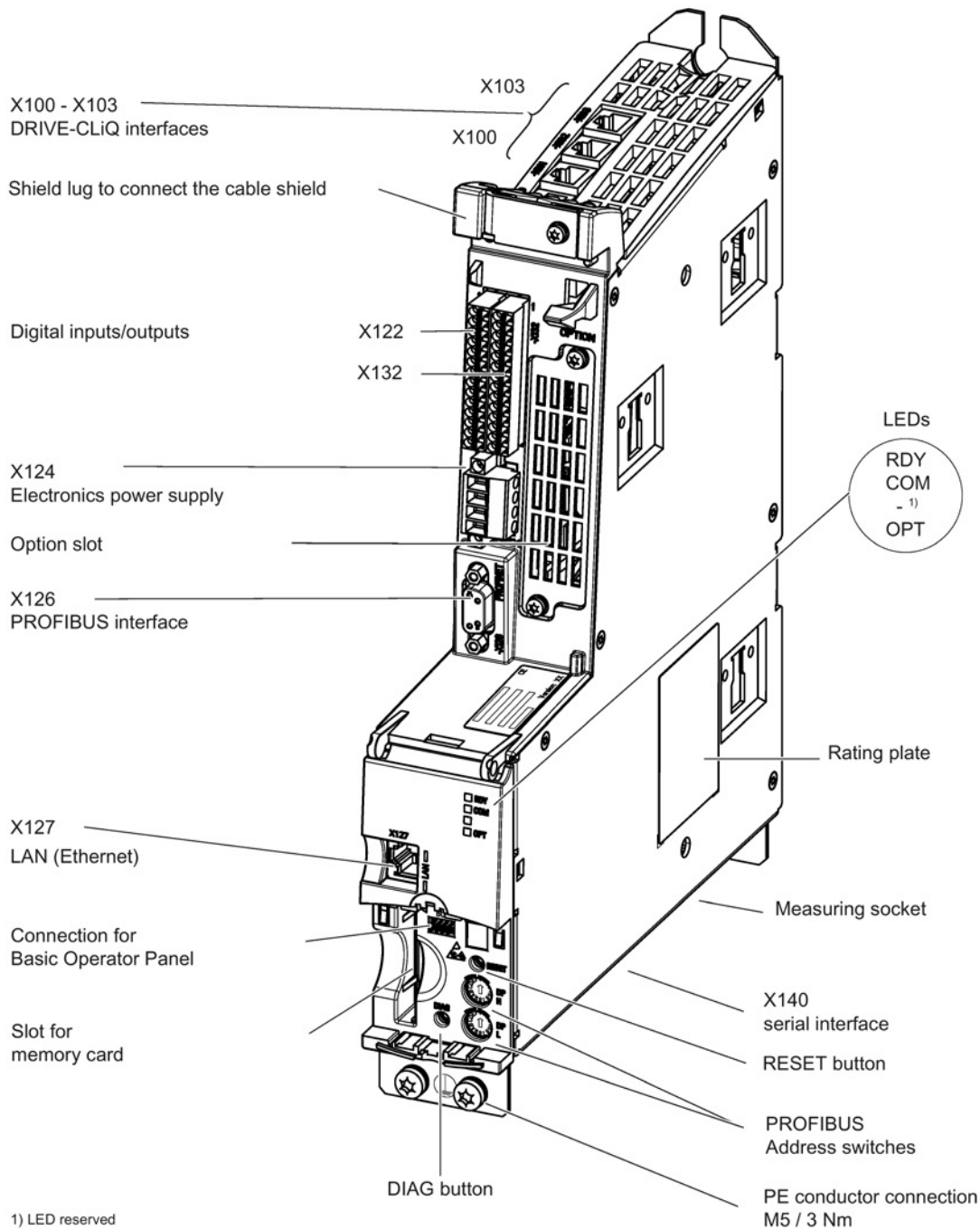

Figure 3-10 Interface overview CU320-2 DP (without cover and blanking cover)

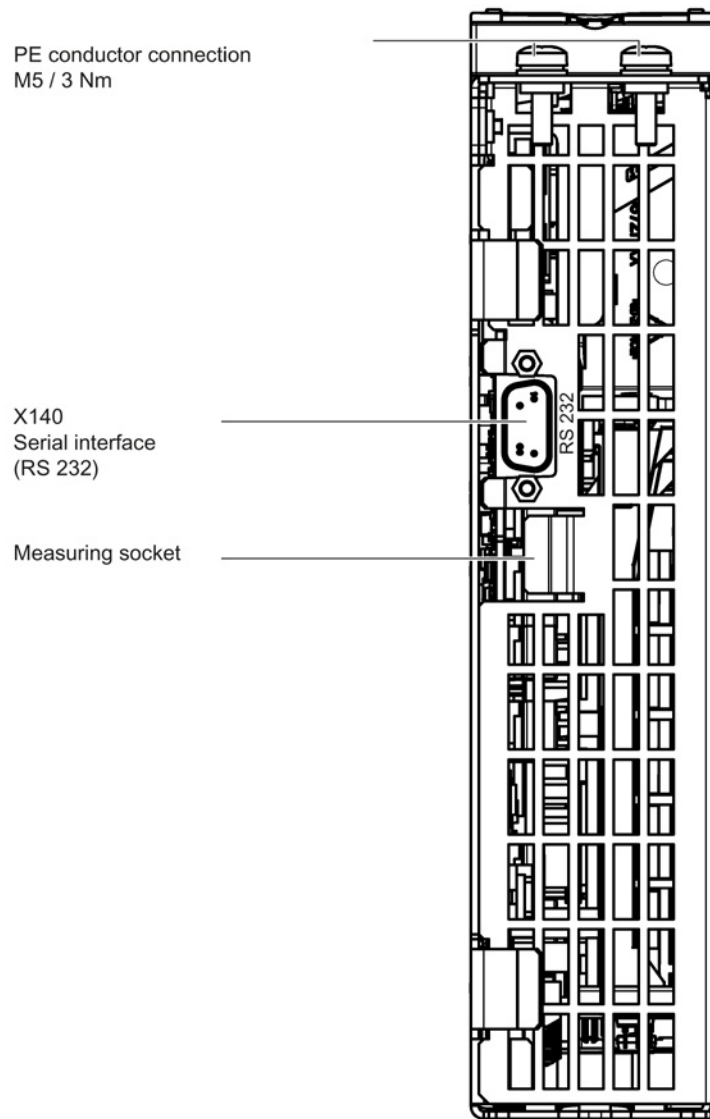

Figure 3-11 Interface X140 and measuring sockets T0 to T2 - CU320-2 DP (view from below)

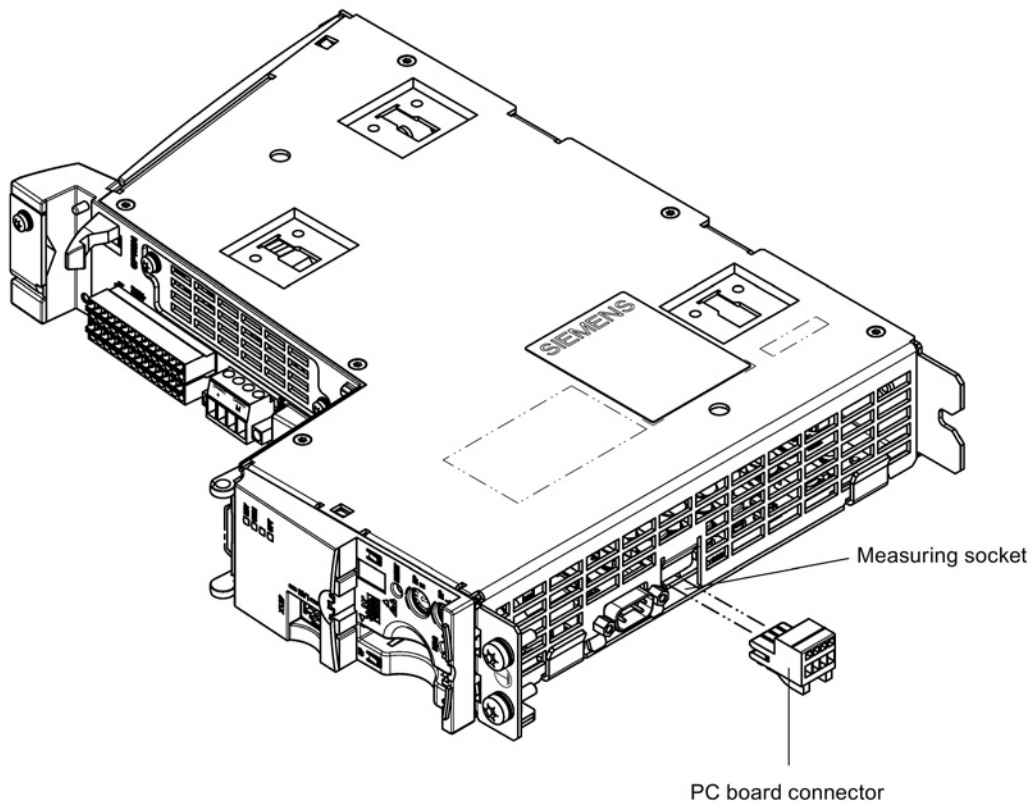

Figure 3-12 Mounting a PC board connector (Phoenix Contact) in the measuring socket

### 3.4.2.2 X100-X103 DRIVE-CLiQ interfaces

Table 3- 17 X100-X103 DRIVE-CLiQ interfaces

	Pin	Signal name	Technical data
	1	TXP	Transmit data +
	2	TXN	Transmit data -
	3	RXP	Receive data +
	4	Reserved, do not use	
	5	Reserved, do not use	
	6	RXN	Receive data -
	7	Reserved, do not use	
	8	Reserved, do not use	
	A	+ (24 V)	Power supply
	B	M (0 V)	Electronics ground
Connector type	DRIVE-CLiQ socket		

The blanking covers for the DRIVE-CLiQ interfaces are included in the scope of delivery.  
 Blanking covers (50 x) Article No.: 6SL3066-4CA00-0AA0

### 3.4.2.3 X122 digital inputs/outputs

Table 3- 18 X122 digital inputs/outputs

	Terminal	Designation <sup>1)</sup>	Technical data
	1	DI 0	Voltage (max.): -3 ... +30 V DC Current consumption, typical: 9 mA at 24 V Electrical isolation: The reference potential is terminal M1 Signal level (incl. ripple) High level: 15 ... 30 V Low level: -3 ... +5 V Input delay (typ.): For "0" → "1": 50 μs For "1" → "0": 150 μs
	2	DI 1	
	3	DI 2	
	4	DI 3	
	5	DI 16	
	6	DI 17	
	7	M1	Reference potential for terminals 1 ... 6
	8	M	Electronics ground
	9	DI/DO 8	<b>As input:</b> Voltage: -3 ... +30 V DC Current consumption, typical: 9 mA at 24 V Signal level (incl. ripple) High level: 15 ... 30 V Low level: -3 ... +5 V DI/DO 8, 9, 10, and 11 are "rapid inputs" <sup>2)</sup> Input delay (typ.) For "0" → "1": 5 μs For "1" → "0": 50 μs <b>As output:</b> Voltage: 24 V DC Max. load current per output: 500 mA Continuous short-circuit proof Output delay (typ./max): <sup>3)</sup> For "0" → "1": 150 μs / 400 μs For "1" → "0": 75 μs / 100 μs Switching frequency: For resistive load: Max. 100 Hz For inductive load: Max. 0.5 Hz For lamp load: Max. 10 Hz Maximum lamp load: 5 W
	10	DI/DO 9	
	11	M	
	12	DI/DO 10	
	13	DI/DO 11	
	14	M	

Type: Spring-loaded terminal 3 (Page 336)  
Max. cross-section that can be connected: 1.5 mm<sup>2</sup>

1) DI: digital input; DI/DO: bidirectional digital input/output; M: electronics ground; M1: reference potential

2) The rapid inputs can be used as probe inputs or as inputs for the external zero mark.

3) Data for:  $V_{cc} = 24 \text{ V}$ ; load  $48 \Omega$ ; high ("1") = 90%  $V_{out}$ ; low ("0") = 10%  $V_{out}$

The maximum cable length that can be connected is 30 m.

---

**Note**

**Ensuring the function of digital inputs**

An open input is interpreted as "low".

Terminal M1 must be connected so that the digital inputs (DI) can function.

This is achieved by using one of the following measures:

1. Providing the ground reference of the digital inputs
2. A jumper to terminal M

**Note:** This removes isolation for these digital inputs.

---

**Note**

If the 24 V supply is briefly interrupted, then the digital outputs are deactivated during this time.

---



### 3.4.2.4 X132 digital inputs/outputs

Table 3- 19 X132 digital inputs/outputs

	Terminal	Designation <sup>1)</sup>	Technical data
	1	DI 4	Voltage (max.): -3 ... +30 V DC Current consumption, typical: 9 mA at 24 V Electrical isolation: The reference potential is terminal M2 Signal level (including ripple) High level: 15 ... 30 V Low level: -3 ... +5 V Input delay (typ.): For "0" → "1": 50 μs For "1" → "0": 150 μs
	2	DI 5	
	3	DI 6	
	4	DI 7	
	5	DI 20	
	6	DI 21	
	7	M2	Reference potential for terminals 1 ... 6
	8	M	Electronics ground
	9	DI/DO 12	<b>As input:</b> Voltage: -3 ... +30 V DC Current consumption, typical: 9 mA at 24 V Signal level (including ripple) High level: 15 ... 30 V Low level: -3 ... +5 V DI/DO 12, 13, 14, and 15 are "rapid inputs" <sup>2)</sup> Input delay (typ.): For "0" → "1": 5 μs For "1" → "0": 50 μs <b>As output:</b> Voltage: 24 V DC Max. load current per output: 500 mA Continuous short-circuit proof Output delay (typ./max): <sup>3)</sup> For "0" → "1": 150 μs / 400 μs For "1" → "0": 75 μs / 100 μs Switching frequency: For resistive load: Max. 100 Hz For inductive load: Max. 0.5 Hz For lamp load: Max. 10 Hz Maximum lamp load: 5 W
	10	DI/DO 13	
	11	M	
	12	DI/DO 14	
	13	DI/DO 15	
	14	M	

Type: Spring-loaded terminal 3 (Page 336)  
Max. cross-section that can be connected: 1.5 mm<sup>2</sup>

1) DI: digital input; DI/DO: bidirectional digital input/output; M: electronics ground; M2: reference potential

2) The rapid inputs can be used as probe inputs or as inputs for the external zero mark

3) Data for:  $V_{cc} = 24 \text{ V}$ ; load  $48 \text{ } \Omega$ ; high ("1") = 90%  $V_{out}$ ; low ("0") = 10%  $V_{out}$

The maximum cable length that can be connected is 30 m.

**Note**

**Ensuring the function of digital inputs**

An open input is interpreted as "low".

To enable the digital inputs (DI) to function, terminal M2 must be connected.

This is achieved by using one of the following measures:

1. Providing the ground reference of the digital inputs
2. A jumper to terminal M

**Note:** This removes isolation for these digital inputs.

**Note**

If the 24 V supply is briefly interrupted, then the digital outputs are deactivated during this time.

**3.4.2.5 X124 electronics power supply**

Table 3- 20 X124 electronics power supply

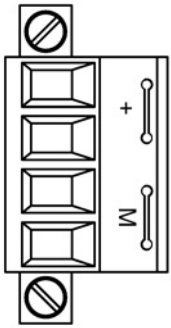
	Terminal	Designation	Technical data
	+	Electronics power supply	Voltage: 24 V DC (20.4 ... 28.8 V) Current consumption: max. 1.0 A (without DRIVE-CLiQ or digital outputs) Max. current through the jumper in the connector: 20 A (15 A according to UL/CSA)
	+	Electronics power supply	
	M	Electronics ground	
	M	Electronics ground	

Type: Screw terminal 2 (Page 336)

The maximum cable length that can be connected is 30 m.

**Note**

The two "+" or "M" terminals are jumpered in the connector. This ensures that the supply voltage is looped through.

The current consumption increases by the value for the DRIVE-CLiQ node and digital outputs.

**Note**

The terminal block must be screwed on tightly using a flat-bladed screwdriver.

**3.4.2.6 X126 PROFIBUS**

The PROFIBUS interface can be operated isochronously.

Table 3- 21 X126 PROFIBUS interface

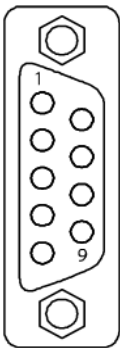
	Pin	Signal name	Meaning	Range
	1	-	Not assigned	
	2	M24_SERV	Teleservice supply, ground	0 V
	3	RxD / TxD-P	Receive/transmit data P (B)	RS485
	4	CNTR-P	Control signal	TTL
	5	DGND	PROFIBUS data reference potential	
	6	VP	Supply voltage plus	5 V ± 10%
	7	P24_SERV	Teleservice supply, + (24 V)	24 V (20.4 ... 28.8 V)
	8	RxD / TxD-N	Receive/transmit data N (A)	RS485
	9	-	Not assigned	

Connector type: 9-pin Sub-D socket

A teleservice adapter can be connected to the PROFIBUS interface for remote diagnostics. The power supply for the teleservice (terminals 2 and 7) can have a load of up to 150 mA.

**NOTICE**

**Damage to the Control Unit or other PROFIBUS nodes as a result of high leakage currents**

If a suitable equipotential bonding conductor is not used, high leakage currents that could destroy the Control Unit or other PROFIBUS nodes can flow through the PROFIBUS cable.

- An equipotential bonding conductor with a cross-section of at least 25 mm<sup>2</sup> must be used between components in a system that are located at a distance from each other.

**NOTICE**

**Damage to the Control Unit or other CAN bus nodes by connecting a CAN bus cable**

If a CAN bus cable is connected to the X126 interface, this can destroy the Control Unit or other CAN bus nodes.

- Do not connect any CAN bus cables to the X126 interface.

**PROFIBUS connectors**

The first and last nodes in a bus must contain terminating resistors. Otherwise, data transmission will not function correctly.



The bus terminating resistors are activated in the connector.

The cable shield must be connected at both ends and over a large surface area.

**3.4.2.7 PROFIBUS address switch**

On the CU320-2 DP, the PROFIBUS address is set as a hexadecimal value via two rotary coding switches. Values between 0<sub>dec</sub> (00<sub>hex</sub>) and 127<sub>dec</sub> (7F<sub>hex</sub>) can be set as the address. The upper rotary coding switch (H) is used to set the hexadecimal value for 16<sup>1</sup> and the lower rotary coding switch (L) is used to set the hexadecimal value for 16<sup>0</sup>.

Table 3- 22 PROFIBUS address switch

Rotary coding switches	Significance	Examples		
		21 <sub>dec</sub>	35 <sub>dec</sub>	126 <sub>dec</sub>
		15 <sub>hex</sub>	23 <sub>hex</sub>	7E <sub>hex</sub>
 DP H	16 <sup>1</sup> = 16	1	2	7
 DP L	16 <sup>0</sup> = 1	5	3	E

**Setting the PROFIBUS address**

The factory setting for the rotary coding switches is 0<sub>dec</sub> (00<sub>hex</sub>).

There are two ways to set the PROFIBUS address:

1. Using a parameter
  - To set the bus address for a PROFIBUS node using STARTER, first set the rotary code switches to 0<sub>dec</sub> (00<sub>hex</sub>) and/or 127<sub>dec</sub> (7F<sub>hex</sub>).
  - Use the parameter to set the address to a value between 1 and 126.

Information can be taken from the following reference:  
 Reference: /LH1/ SINAMICS S120/S150 List Manual

2. Using the PROFIBUS address switches on the Control Unit
  - The address is set manually to values between 1 and 126 using the rotary coding switches. In this case, the parameter is only used to read the address.

**Note**

The rotary coding switches used to set the PROFIBUS address are located beneath the cover.

**More information**

Additional information for setting the PROFIBUS address is available in the SINAMICS S120 Function Manual.

**3.4.2.8 X127 LAN (Ethernet)**

Table 3- 23 X127 LAN (Ethernet)

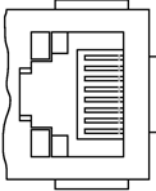
	Pin	Signal name	Technical data
	1	TXP	Ethernet transmit data +
	2	TXN	Ethernet transmit data -
	3	RXP	Ethernet receive data +
	4	Reserved, do not use	
	5	Reserved, do not use	
	6	RXN	Ethernet receive data -
	7	Reserved, do not use	
	8	Reserved, do not use	
Connector type: RJ45 socket			

**Note**

The LAN (Ethernet) interface does not support Auto MDI(X). For this reason, only crossed cables may be used to connect devices.

For diagnostic purposes, the X127 LAN interface features a green and a yellow LED. These LEDs indicate the following status information:

Table 3- 24 LED statuses for the X127 LAN interface

LED	Color	Status	Description
Link port	-	Off	Missing or faulty link
	Green	Continuous light	10 or 100 Mbit link available
Activity port	-	Off	No activity
	Yellow	Flashing light	Sending or receiving

### 3.4.2.9 X140 serial interface (RS232)

An external display and operator device for operator control/parameterization can be connected via the serial interface. The interface is located on the lower side of the Control Unit.

Table 3- 25 X140 serial interface (RS232)

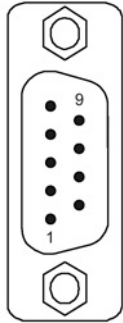
	Pin	Signal name	Technical data
	1	Reserved, do not use	
	2	RxD	Receive data
	3	TxD	Transmit data
	4	Reserved, do not use	
	5	Ground	Ground reference
	6	Reserved, do not use	
	7	Reserved, do not use	
	8	Reserved, do not use	
	9	Reserved, do not use	
Connector type: 9-pin SUB D connector			

### 3.4.2.10 Measuring socket

Table 3- 26 Measuring socket with mounted PC board connector

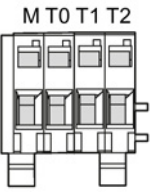
	Socket	Function	Technical data
	M	Ground	Voltage: 0... 5 V Resolution: 8 bits Load current: max. 3 mA Continuous short-circuit proof The reference potential is terminal M
	T0	Measuring terminal 0	
	T1	Measuring terminal 1	
	T2	Measuring terminal 2	
PC board connector, Phoenix Contact, type: ZEC 1.0/ 4-ST-3.5 C1 R1.4, Article number: 1893708			

**Note**

**Cable cross section**

The measuring terminals are only suitable for conductor cross-sections of 0.2 mm<sup>2</sup> up to 1 mm<sup>2</sup>.

**Note**

**Use of the measuring socket**

The measuring socket supports commissioning and diagnostic functions. It must not be connected for normal operation.

### 3.4.2.11 Buttons

#### RESET button

Pressing the RESET button restarts the device, just the same as after connecting the electronics power supply (cold restart).

#### DIAG button

The DIAG pushbutton is reserved for service functions.

### 3.4.2.12 Slot for memory card



Figure 3-13 Slot for memory card

**! WARNING**

**Danger to life due to software manipulation when using exchangeable storage media**

The storage of files on removable storage media involves a high risk of infection, e.g. via viruses or malware. As a result of incorrect parameterization, machines can malfunction, which in turn can lead to injuries or death.

- Protect the files on removable storage media against malware through appropriate protective measures, e.g. virus scanners.

---

**Note**

**Possible plant standstill by withdrawing or inserting the memory card in operation**

If the memory card is withdrawn or inserted during operation, then data can be lost, possibly resulting in a plant standstill.

- Only withdraw and insert the memory card when the Control Unit is in a no-voltage condition.
- 

**Note**

**Insertion direction for the memory card**

Only insert the memory card as shown in the photo above (arrow at top right).

---



**NOTICE**

**Memory card damage caused by electric fields or electrostatic discharge**

Electrical fields or electrostatic discharge may result in the memory card being damaged.

- When removing and inserting the memory card, always observe the ESD regulations (Page 23).
- 

**Note**

**Possible data loss when returning the Control Unit with memory card**

When returning a defective Control Unit for repair or testing, the data on the memory card (parameters, firmware, licenses, etc.) could be lost.

- Do not return the memory card as well, but keep it in a safe place so that it can be inserted in the replacement unit.
- 

**Note**

Please note that only SIEMENS memory cards can be used to operate the Control Unit.

---



### 3.4.3 Connection example

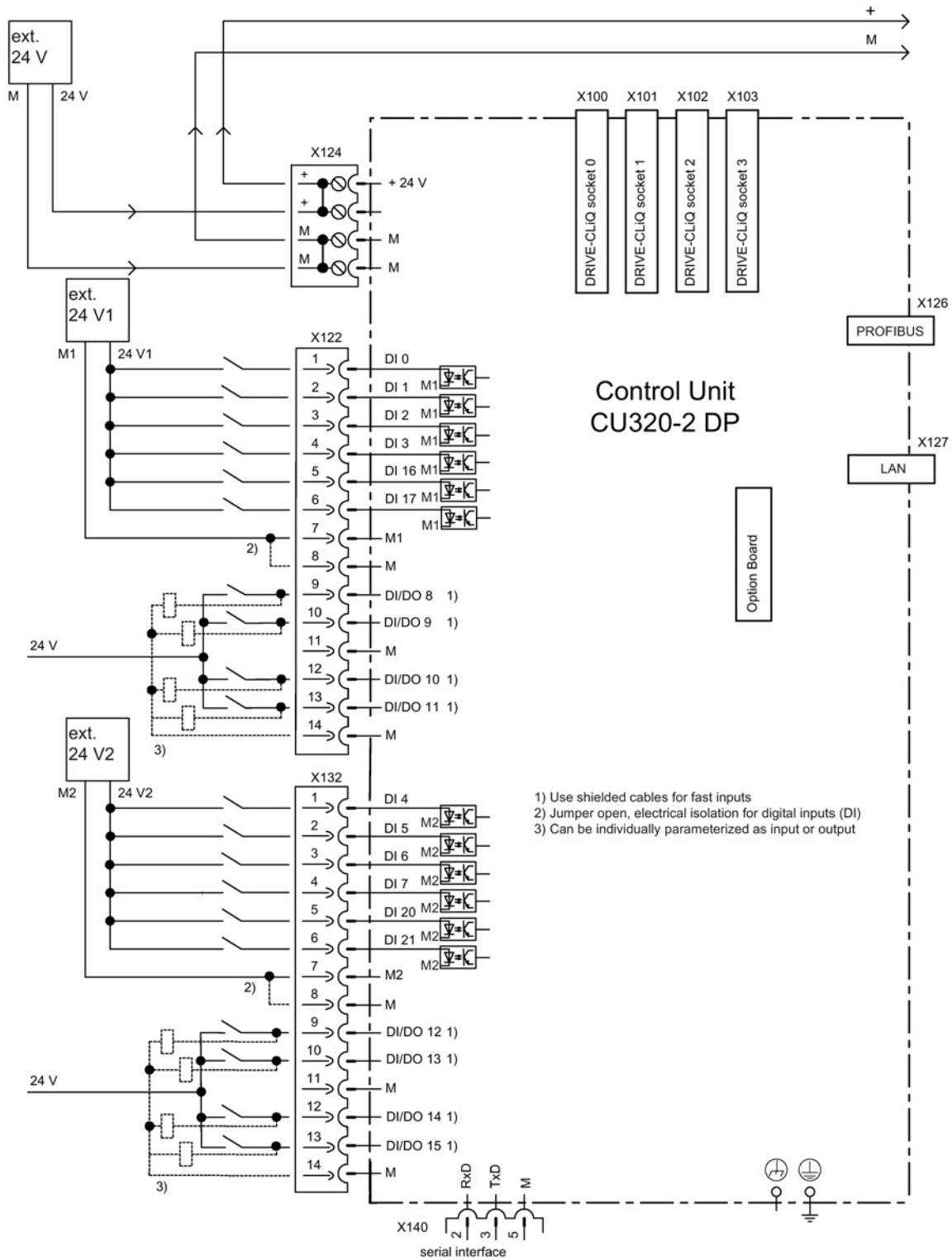

Figure 3-14 Connection example of CU320-2 DP

### 3.4.4 Meaning of the LEDs

#### 3.4.4.1 Description of the LED statuses

The different statuses that arise during the booting procedure are indicated by means of the LEDs on the Control Unit.

- The duration of the individual statuses varies.
- If an error occurs, the booting procedure is terminated and the cause is indicated accordingly via the LEDs.
- Once the unit has successfully booted up, all the LEDs are switched off briefly.
- Once the unit has booted up, the LEDs are controlled via the loaded software.

#### 3.4.4.2 Behavior of the LEDs during booting

Table 3- 27 Load software

LED			Status	Comment
RDY	COM	OPT		
Red	Orange	Orange	Reset	Hardware reset RDY LED lights up red, all other LEDs light up orange
Red	Red	Off	BIOS loaded	–
Red flashing light 2 Hz	Red	Off	BIOS error	• Error occurred while loading the BIOS
Red flashing light 2 Hz	Red flashing light 2 Hz	Off	File error	• Memory card not inserted or defective • Software on memory card not present or corrupted
Red	Orange Flashing light	Off	FW loading	RDY LED lights up red, COM LED flashes orange without fixed frequency
Red	Off	Off	FW loaded	–
Off	Red	Off	FW checked (no CRC error)	–
Red flashing light 0.5 Hz	Red flashing light 0.5 Hz	Off	FW checked (CRC error)	• CRC invalid

Table 3- 28 Firmware

LED			Status	Comment
RDY	COM	OPT		
Orange	Off	Off	Initializing	–
Alternating			Running	See the table below

### 3.4.4.3 Behavior of the LEDs in the operating state

Table 3- 29 Control Unit CU320-2 DP – Description of the LEDs after booting

LED	Color	Status	Description, cause	Remedy
RDY (READY)	-	OFF	Electronics power supply is missing or outside the permissible tolerance range.	Check power supply
	Green	Continuous light	The component is ready for operation and cyclic DRIVE-CLiQ communication is taking place.	-
		Flashing light 0.5 Hz	Commissioning/reset	-
		Flashing light 2 Hz	Writing to the memory card	-
	Red	Flashing light 2 Hz	General error	Check parameterization/configuration data
	Red/green	Flashing light 0.5 Hz	Control Unit is ready for operation. However, there are no software licenses.	Obtain licenses
	Orange	Flashing light 0.5 Hz	Updating the firmware of the DRIVE-CLiQ components	-
		Flashing light 2 Hz	DRIVE-CLiQ component firmware update complete. Wait for POWER ON for the components in question.	Turn POWER ON for the components in question
	Green/orange or red/orange	Flashing light 2 Hz	Component recognition via LED is activated. <b>Note:</b> Both options depend on the LED status when component recognition is activated.	-
COM PROFIdrive cyclic operation	-	Off	Cyclic communication has not (yet) taken place. <b>Note:</b> The PROFIdrive is ready to communicate when the Control Unit is ready to operate (see LED RDY).	-
	Green	Continuous light	Cyclic communication is taking place.	-
		Flashing light 0.5 Hz	Full cyclic communication has not yet taken place. Possible causes: <ul style="list-style-type: none"> <li>• The controller is not transferring any set-points.</li> <li>• During isochronous operation, no global control (GC) or a faulty global control (GC) is transferred by the controller.</li> </ul>	-
	Red	Flashing light 0.5 Hz	PROFIBUS master is sending wrong parameterization/configuration data	Adapt configuration between master/controller and CU
		Flashing light 2 Hz	Cyclic bus communication has been interrupted or could not be established	Remove fault

3.4 Control Unit CU320-2 DP (PROFIBUS)

LED	Color	Status	Description, cause	Remedy
OPT (OPTION)	-	Off	Electronics power supply is missing or outside the permissible tolerance range. Component is not ready. Option board not installed or no associated drive object has been created.	Check power supply and/or component
	Green	Continuous light	Option board is ready.	-
		Flashing light 0.5 Hz	Depends on the Option Board used.	-
	Red	Flashing light 2 Hz	This component has at least one fault. The Option Board is not ready (e.g. after switching on).	Remove the fault and acknowledge
RDY and COM	Red	Flashing light 2 Hz	Bus error - communication has been interrupted	Remove fault
RDY and OPT	Orange	Flashing light 0.5 Hz	The firmware of the connected option board is being updated.	-

3.4.5 Dimension drawing

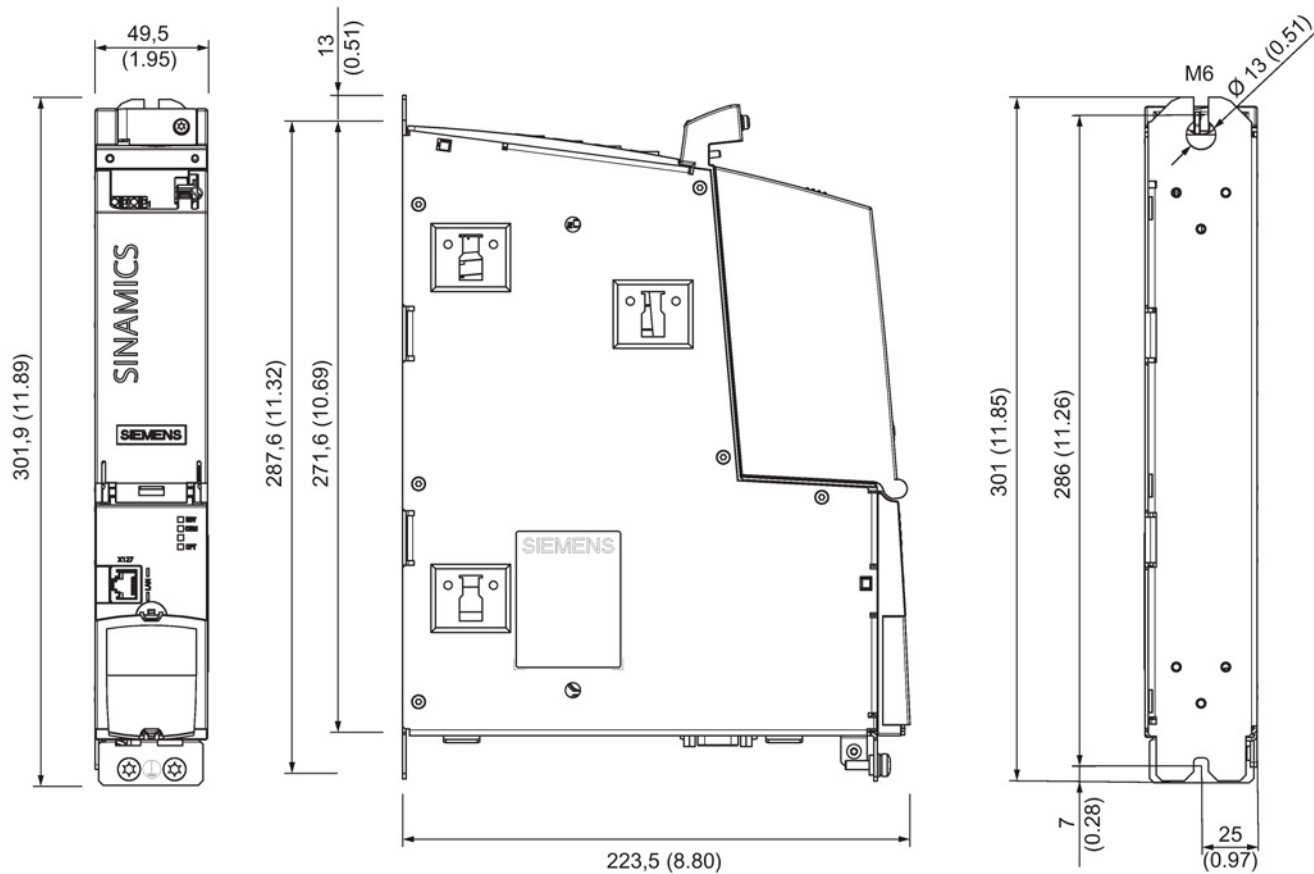

Figure 3-15 Dimension drawing of CU320-2 DP, all data in mm and (inches)

### 3.4.6 Technical data

Table 3- 30 Technical data

<b>6SL3040-1MA00-0AA0</b>	<b>Unit</b>	<b>Value</b>
Electronics power supply		
Voltage	V <sub>DC</sub>	24 (20.4 ... 28.8)
Current (without DRIVE-CLiQ and digital outputs)	A <sub>DC</sub>	1.0
Power loss	W	24
Total maximum permissible output currents	A	5.5
Maximum DRIVE-CLiQ cable length	m	100
PE/ground connection	On the housing with M5/3 Nm screw	
Response time	The response time of digital inputs/outputs depends on the evaluation (refer to the function diagram). Additional information can be taken from the following references: Reference: /LH1/ SINAMICS S120/S150 List Manual, Chapter "Function diagrams/CU320-2 Input/Output terminals"	
Weight	kg	2.3

### 3.5 Mounting Control Units

#### 3.5.1 Mounting to a Line Module

##### Mounting a CU320-2 Control Unit directly on a Line Module, booksize or chassis format

You must attach three support brackets to a Line Module in order to mount a Control Unit directly on it. The support brackets are supplied in the Line Module accessories kit.

Table 3- 31 Mounting support brackets for a Control Unit onto a Line Module

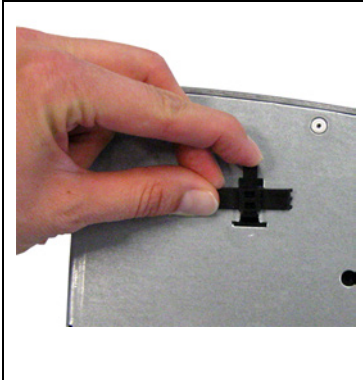
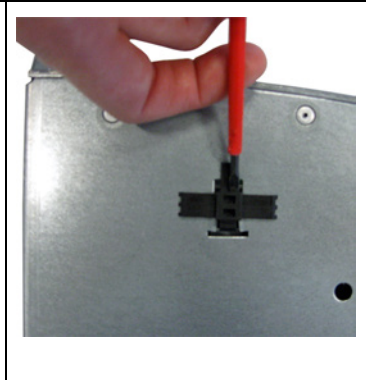
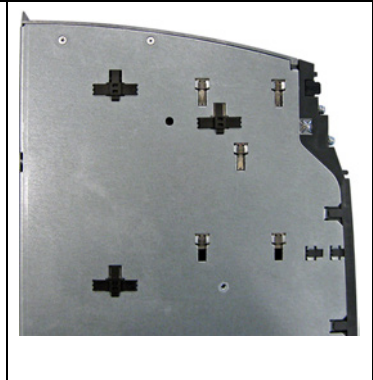
		
<p>1. Insert the first support bracket into the mounting opening provided at the Line Module.</p>	<p>2. Insert the support bracket up to the end stop using a suitable tool (screwdriver).</p>	<p>3. Mount the additional support brackets as described under Points 1 and 2.</p>

Then mount the Control Unit onto the Line Module as shown below.

Table 3- 32 Installing the Control Unit on a Line Module using the CU320-2 DP as an example

<p>1. Mount the Control Unit onto the Line Module using the 3 support brackets.</p>	<p>2. Push down the Control Unit onto the support brackets until it latches into place.</p>	<p>3. The front of the mounted Control Unit must be flush with the Line Module.</p>

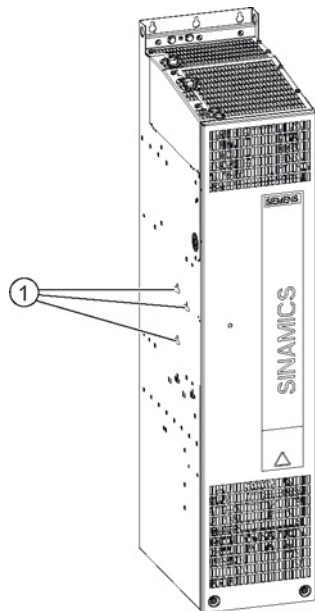

① Opening on the Line Module Chassis for fastening the Control Unit

Figure 3-16 Mounting a Control Unit on a Line Module, chassis format

### 3.5.2 Mounting on the mounting surface

#### Mounting a CU320-2 Control Unit directly onto a mounting surface

Mount the fixing lug of the Control Unit on the mounting surface using M6 screws.

Tightening torque: 6 Nm

#### Mounting a CU320-2 Control Unit to a mounting surface using spacers

To increase the mounting depth of the Control Unit to the 270 mm mounting depth of a Line Module in the booksize format, mount spacers (2 pieces: 6SL3064-1BB00-0AA0) as shown below to the Control Unit.

**Tools required:**

- Torx screwdriver T10 for the screws (M3) of the spacer

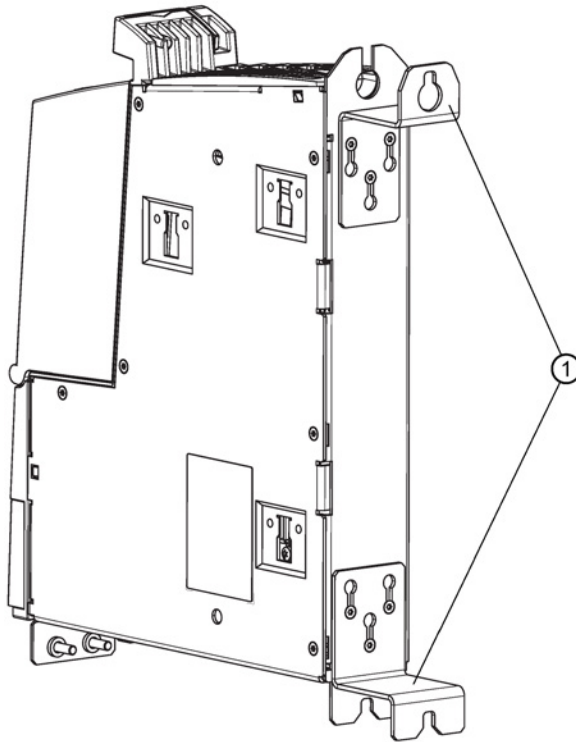

① Spacer

Figure 3-17 CU320-2 with spacers for mounting on a mounting surface



### 3.5.3 Opening and removing the cover

Table 3- 33 Opening and lifting the cover using the CU320-2 DP as an example





		
<p>Release the cover by gently pressing the release lug.</p>	<p>Swivel the cover to the front to open it.</p>	<p>Control Unit with cover open</p>

Table 3- 34 Removing the cover using a CU320-2 DP as an example

	
<p>Release the cover by gently applying lateral pressure at the joint.</p>	<p>Swivel the cover to the side to remove it.</p>

## 3.6 Basic Operator Panel BOP20

### 3.6.1 Description

The Basic Operator Panel BOP20 contains 6 keys and a backlit display unit. The BOP20 can be plugged onto a SINAMICS Control Unit and operated.

**The following functions are possible with the BOP:**

- Input of parameters and activation of functions
- Display of operating modes, parameters, alarms and faults

### 3.6.2 Interface description



Figure 3-18 Basic Operator Panel BOP20

## Overview of displays and keys

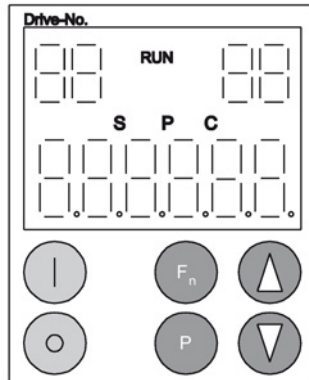







Figure 3-19 Overview of displays and keys

Table 3- 35 Displays

Display	Meaning
Top left 2 positions	The active drive object of the BOP is displayed here. The displays and key operations always refer to this drive object.
RUN	Is lit (bright) if the displayed drive is in the RUN state (in operation).
Top right 2 positions	The following is displayed in this field: <ul style="list-style-type: none"> <li>• More than 6 digits: Characters that are present but cannot be seen (e.g. "r2" → 2 characters to the right are invisible, "L1" → 1 character to the left is invisible)</li> <li>• Faults: Selects/displays other drives with faults</li> <li>• Designation of BICO inputs (bi, ci)</li> <li>• Designation of BICO outputs (bo, co)</li> </ul> Source object of a BICO interconnection to a drive object other than the active one.
S	Is (bright) if at least one parameter was changed and the value was not transferred into the non-volatile memory.
P	Is lit (bright) if, for a parameter, the value only becomes effective after pressing the P key.
C	Is light (bright) if at least one parameter was changed and the calculation for consistent data management has still not been initiated.
Below, 6 position	Displays, e.g. parameters, indices, faults and alarms.

### BOP20 keyboard

Table 3- 36 Assignment of the BOP20 keyboard

Key	Name	Meaning
	ON	Powering-up the drives for which the command "ON/OFF1", "OFF2" or "OFF3" should come from the BOP.
	OFF	Power-down the drives for which the "ON/OFF1," "OFF2," or "OFF3" commands should come from the BOP.
		<p><b>Note:</b></p> <p>The effectiveness of these keys can be defined using the appropriate BICO parameterization (e.g. using these keys, it is possible to simultaneously control all of the axes that have been configured.)</p> <p>The structure of the BOP control word corresponds to the structure of the PROFIBUS control word.</p>
	Functions	<p>The meaning of these keys depends on the actual display.</p> <p><b>Note:</b></p> <p>The effectiveness of this key to acknowledge faults can be defined using the appropriate BICO parameterization.</p>
	Parameter	The meaning of these keys depends on the actual display.
	Raise	The keys are dependent on the actual display and are used to raise or lower values.
	Lower	





### Display and operator controls of the BOP20

For information about display and operator controls of the BOP20, refer the SINAMICS S120 Commissioning Manual.

#### 3.6.3 Mounting at the Control Unit

<p><b>NOTICE</b></p> <p><b>Damage to the interface for the BOP20 at the Control Unit through tilting</b></p> <p>If the BOP20 is skewed when inserting or withdrawing it, this can damage the interface for the BOP20.</p> <ul style="list-style-type: none"> <li>• Make sure that you insert and withdraw the BOP20 straight into/out of the Control Unit and that it is not tilted up or down.</li> </ul>
--

Table 3- 37 Mounting a Basic Operator Panel BOP20 using the CU320-2 DP as an example

	
<p>1. Press the latching cams together and remove the blanking cover.</p>	<p>2. Insert the memory card in the slot provided.</p>
	
<p>3. Press the latching cams on the BOP20 together, and push the BOP20 <b>straight</b> in until you hear it latch into position.</p>	<p>CU320-2 DP with BOP20 installed</p>

### 3.6.4 Removal

Please note the following information when removing the BOP20 from the Control Unit:

1. Simultaneously press the latching cams on the BOP20.
2. Always withdraw the BOP20 straight out (without skewing it). Never withdraw the BOP20 by pulling it at its lower edge, as this could damage the interface at the rear.

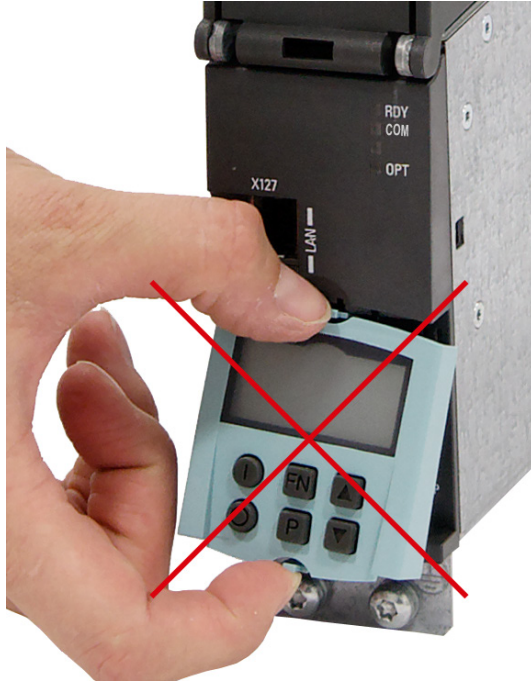



Figure 3-20 **Incorrect removal** of the BOP20 from a CU320-2 DP (example)

## Option boards

### 4.1 Safety instructions for option boards

 <b>WARNING</b>
<b>Danger to life if the fundamental safety instructions and remaining risks are not carefully observed</b>
If the fundamental safety instructions and remaining risks in Chapter 1 (Page 19) are not observed, accidents involving severe injuries or death may occur.
<ul style="list-style-type: none"><li>• Adhere to the fundamental safety instructions.</li><li>• When assessing the risk, take into account remaining risks.</li></ul>

<b>NOTICE</b>
<b>Damage or malfunctions to the Option Board by inserting and withdrawing in operation</b>
Withdrawing and inserting Option Boards during operation can damage them or cause the Option Boards to malfunction.
<ul style="list-style-type: none"><li>• Only withdraw or insert Option Boards when the Control Unit is in a current-free state.</li></ul>

## 4.2 CAN Communication Board CBC10

### 4.2.1 Description

The Communication Board CAN CBC10 is a communication module for linking to the CAN bus. The Communication Board is inserted into the option slot on a Control Unit.

### 4.2.2 Interface description

#### 4.2.2.1 Overview

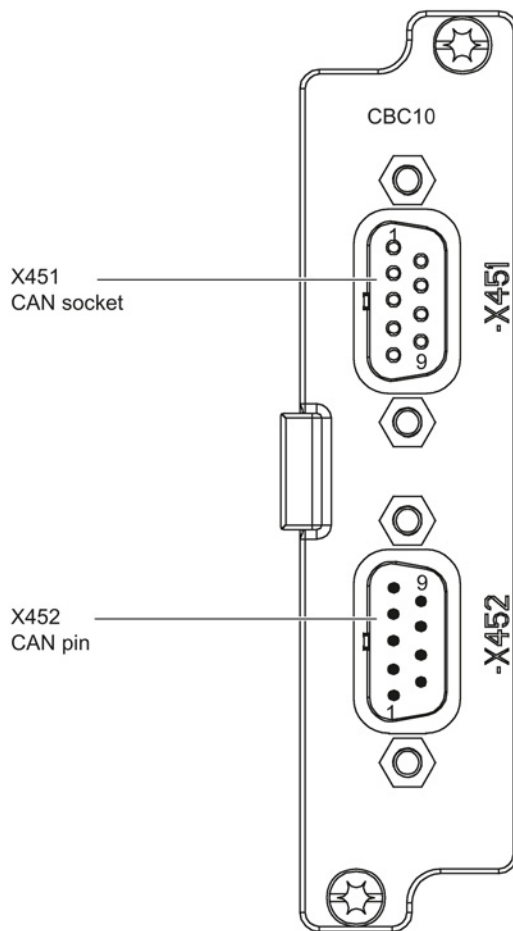
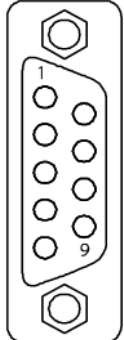

Figure 4-1 Interface overview of the CBC10



### 4.2.2.2 X451 CAN bus interface

Table 4- 1 X451: CAN bus interface

	Pin	Designation	Technical data
	1	Reserved, do not use	
	2	CAN_L	CAN signal (dominant low)
	3	CAN_GND	CAN ground
	4	Reserved, do not use	
	5	CAN_SHLD	Optional shield
	6	GND	CAN ground
	7	CAN_H	CAN signal
	8	Reserved, do not use	
	9	Reserved, do not use	
Type: SUB-D female, 9-pin			

#### NOTICE

##### Destruction of the CAN bus interface as a result of an incorrect connector

If PROFIBUS connectors are connected to CAN bus interfaces during operation, this may lead to the CAN bus interfaces being destroyed.

- Do not connect PROFIBUS connectors to CAN bus interfaces.

### 4.2.2.3 X452 CAN bus interface

Table 4- 2 X452: CAN bus interface

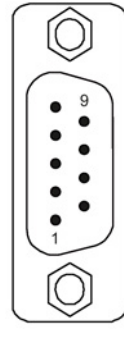
	Pin	Designation	Technical data
	1	Reserved, do not use	
	2	CAN_L	CAN signal (dominant low)
	3	CAN_GND	CAN ground
	4	Reserved, do not use	
	5	CAN_SHLD	Optional shield
	6	GND	CAN ground
	7	CAN_H	CAN signal
	8	Reserved, do not use	
	9	Reserved, do not use	
Type: 9-pin SUB-D male			

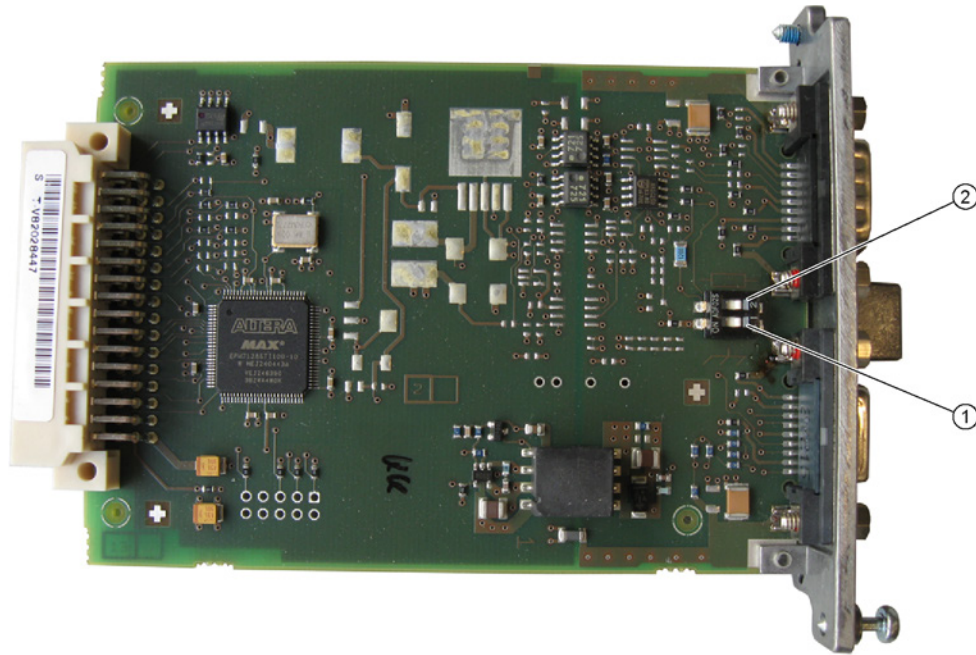

4.2.2.4 2-pin SMD DIL switch



- ① Switch 1
- ② Switch 2

Figure 4-2 2-pin SMD DIL switch 1 and 2 on the CBC10

Table 4-3 2-pin SMD DIL switch

ID on the component	Switch	Function	Switch position		Default
	2	Bus terminating resistor 120 Ω	OFF	Inactive	OFF
			ON	Active	
	1	Operation with/without ground	OFF	Ungrounded oper- ation	OFF
			ON	Operation with ground	

### 4.2.3 Meaning of the LED

Table 4- 4 Meaning of the LED on the Communication Board CAN CBC10

LED	Color	Status	Description, cause	Remedy
OPT on the Con- trol Unit	–	OFF	Electronics power supply is missing or outside the permissible tolerance range. Communication Board either defective or not inserted.	–
	Green	Continuous light	OPERATIONAL	–
		Flashing light	PREOPERATIONAL No PDO communication possible	–
		Single flash	STOPPED Only NMT communication possible	
	Red	Continuous light	BUS OFF	Check baud rate Check cabling
		Single flash	ERROR PASSIVE MODE The error counter for "error passive" has reached the value 127. After the SINAMICS drive system had powered up, no additional active CAN components were connected to the bus	Check baud rate Check cabling
		Double flash	Error Control Event, a Guard Event has occurred	Check connection to CANopen master

### 4.2.4 Installation

1. Release the appropriate screws to remove the cover plate from the option slot.
2. Insert the module into the option slot of the Control Unit and fix it in place using the screws.

**Screws:** M3

**Tool:** Torx T10 screwdriver

**Tightening torque:** 0.8 Nm

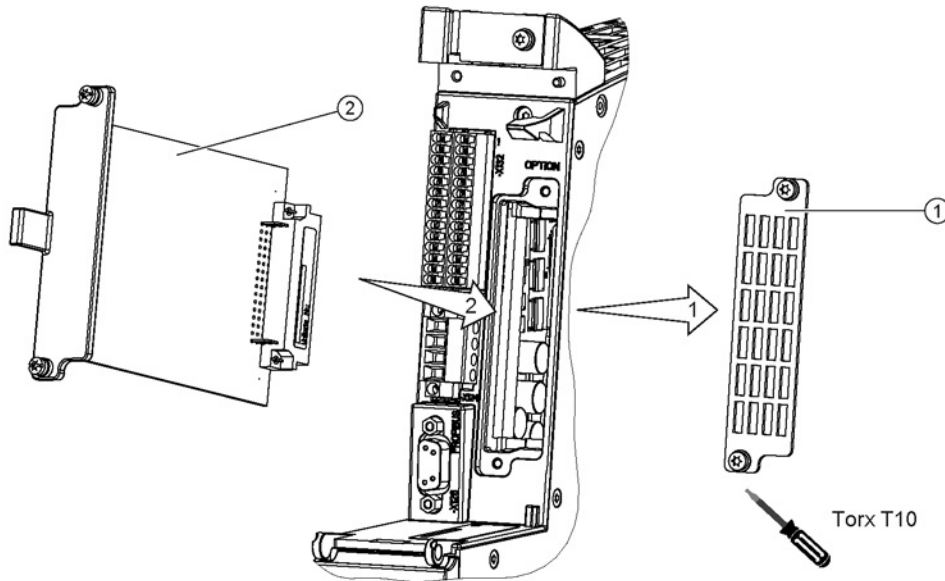

- ① Protective cover
- ② Option Board

Figure 4-3 Installing an Option Board using a CU320-2 DP as an example

### 4.2.5 Technical data

Table 4- 5 Technical data

CAN CBC10 Communication Board 6SL3055-0AA00-2CAx	Unit	Value
Max. current drawn (at 24 V DC)	A <sub>DC</sub>	0.1
Power loss	W	<10
Weight	kg	0.1

## 4.3 Communication Board Ethernet CBE20

### 4.3.1 Description

The SINAMICS S120 system can be connected to PROFINET using the Communication Board Ethernet CBE20 interface board. The module supports PROFINET IO with Isochronous Realtime Ethernet (IRT) and PROFINET IO with RT.

The Communication Board has an Ethernet interface with 4 ports for communication. It is inserted into the option slot on a Control Unit.

---

#### Note

Only one communication interface can be used in isochronous operation when operating the Communication Board CBE20 in a Control Unit CU320-2.

- For the CU320-2 DP, this is either the DP interface of the Control Unit, or the PN interfaces of the CBE20.
  - For the CU320-2 PN, either the internal PN interfaces or the external PN interfaces of the CBE20 are used in isochronous operation.
- 

### 4.3.2 Interface description

#### 4.3.2.1 Overview

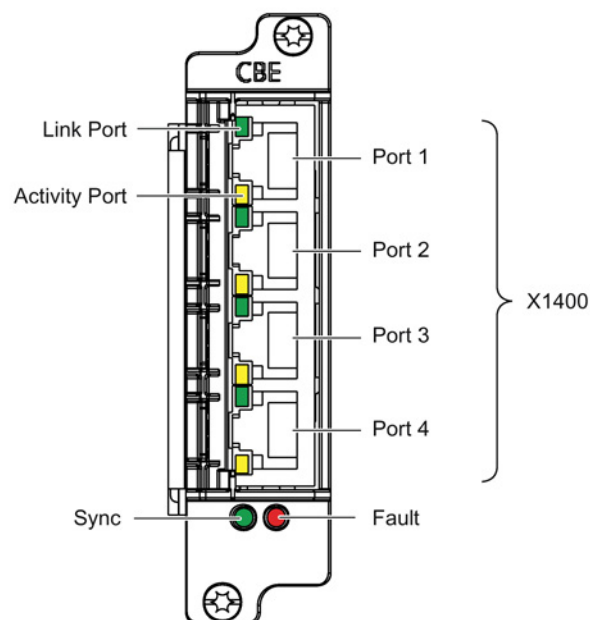
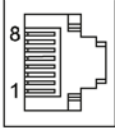

Figure 4-4 Interface overview CBE20

### 4.3.2.2 X1400 Ethernet interface

Table 4- 6 X1400: Ethernet, ports 1-4

	Pin	Signal name	Technical data
	1	RXP	Receive data +
	2	RXN	Receive data -
	3	TXP	Transmit data +
	4	Reserved, do not use	
	5	Reserved, do not use	
	6	TXN	Transmit data -
	7	Reserved, do not use	
	8	Reserved, do not use	
	Screened back-shell	M_EXT	Screen, permanently connected
Connector type	RJ45 socket		

For diagnostic purposes, the ports have one green and one yellow LED (refer to Meaning of the LEDs (Page 94) for descriptions)

Cable type: Industrial Ethernet  
 Max. cable length: 100 m

### 4.3.3 Meaning of the LEDs

#### Meaning of the LEDs on the CBE20 Communication Board Ethernet

Table 4- 7 Meaning of the LEDs at ports 1 to 4 of the X1400 interface

LED	Color	Status	Description
Link port	–	Off	The electronics power supply is missing or outside the permissible tolerance range (link missing or defective).
	Green	Continuous light	A different device is connected to port x and a physical connection exists.
Activity port	–	Off	The electronics power supply is missing or outside the permissible tolerance range (no activity).
	Yellow	Flashing light	Data is being received or sent at port x.

Table 4- 8 Meaning of the Sync and Fault LEDs on the CBE20

LED	Color	Status	Description
Fault	–	Off	If the link port LED is green: The CBE20 is operating normally, data is being exchanged with the configured IO Controller.
	Red	Flashing light	<ul style="list-style-type: none"> <li>The response monitoring interval has elapsed.</li> <li>Communications is interrupted.</li> <li>The IP address is incorrect.</li> <li>Incorrect or no configuration.</li> <li>Incorrect parameter settings.</li> <li>Incorrect or missing device name.</li> <li>IO Controller not connected/switched off, although an Ethernet connection has been established.</li> <li>Other CBE20 faults</li> </ul>
		Continuous light	CBE20 fault error <ul style="list-style-type: none"> <li>No physical connection to a subnet/switch.</li> <li>Incorrect transmission rate</li> <li>Full duplex transmission is not activated.</li> </ul>
Sync	–	Off	If the link port LED is green: The Control Unit task system is not synchronized with the IRT clock. An internal substitute clock is generated.
	Green	Flashing light	The Control Unit task system has synchronized with the IRT clock and data is being exchanged.
		Continuous light	The Task system and the MC-PLL have synchronized with the IRT clock.

Table 4- 9 Meaning of the OPT LED on the Control Unit

LED	Color	Status	Description, cause	Remedy
OPT	–	OFF	The electronics power supply is missing or outside the permissible tolerance range. Communication Board either defective or not inserted.	–
	Green	Continuous light	Communication Board is ready and cyclic communication is taking place.	–
		Flashing light 0.5 Hz	The Communication Board is ready, but cyclic communications is not running. Possible causes: <ul style="list-style-type: none"> <li>At least one fault is present.</li> <li>Communication is being established.</li> </ul>	–
	Red	Continuous light	Cyclic communication via PROFINET has not yet been established. However, non-cyclic communications are possible. SINAMICS waits for a parameterizing/configuring telegram	–

LED	Color	Status	Description, cause	Remedy
		Flashing light 0.5 Hz	The firmware update into the CBE20 has been completed with an error. Possible causes: <ul style="list-style-type: none"> <li>• The CBE20 is defective.</li> <li>• The memory card for the Control Unit is defective.</li> </ul> In this state CBE20 cannot be used.	–
		Flashing light 2 Hz	There is a communications error between the Control Unit and the CBE20. Possible causes: <ul style="list-style-type: none"> <li>• Board was withdrawn after booting.</li> <li>• The board is defective</li> </ul>	Correctly insert the board, if required, replace.
	Orange	Flashing light 0.5 Hz	Firmware is being updated.	–

### 4.3.4 Installation

1. Release the appropriate screws to remove the cover plate from the option slot.
2. Insert the module into the option slot of the Control Unit and fix it in place using the screws.

**Screws:** M3  
**Tool:** Torx T10 screwdriver  
**Tightening torque:** 0.8 Nm

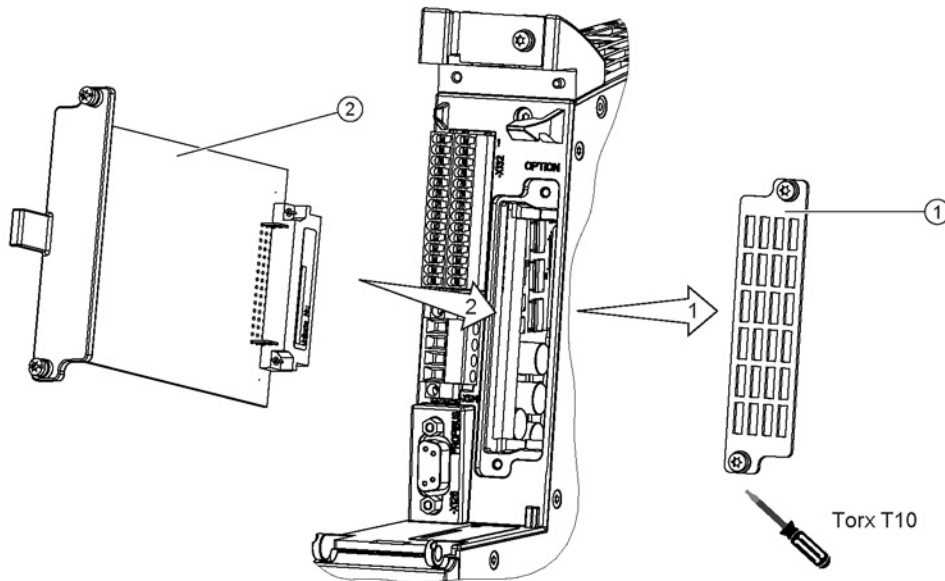

- ① Protective cover
- ② Option Board

Figure 4-5 Installing the Option Board using a CU320-2 DP as an example



### 4.3.5 Technical data

Table 4- 10 Technical data

<b>Communication Board CBE20 6SL3055-0AA00-2EBx</b>	<b>Unit</b>	<b>Value</b>
Max. current requirements (at 24 V DC)	A <sub>DC</sub>	0.1
Power loss	W	2,4
Weight	kg	<0.1

## 4.4 Terminal Board TB30

### 4.4.1 Description

The TB30 Terminal Board is a terminal expansion module that is inserted in the option slot of the Control Unit.

The TB30 Terminal Board has the following terminals:

Table 4- 11 Interface overview

Type	Quantity
Digital inputs	4
Digital outputs	4
Analog inputs	2
Analog outputs	2

### 4.4.2 Interface description

#### 4.4.2.1 Overview

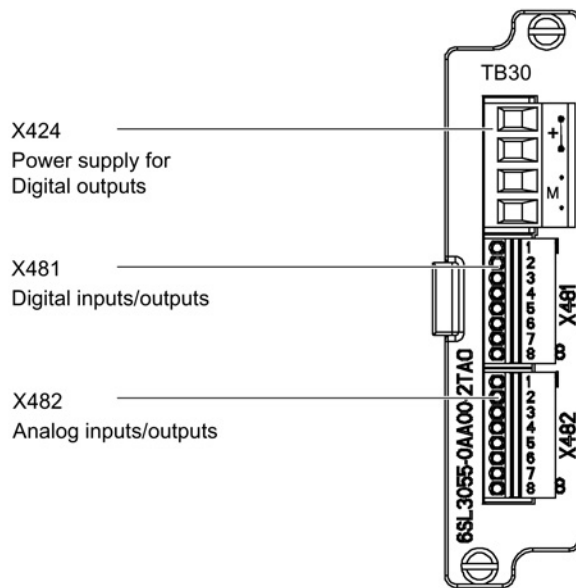
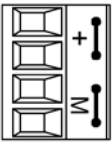

Figure 4-6 Interface overview of the TB30

### 4.4.2.2 X424 power supply, digital outputs

Table 4- 12 X424: Power supply

	Terminal	Designation	Technical data
	+	Power supply	Voltage: 24 V DC (20.4 ... 28.8 V) Current consumption: Max. 4 A (per digital output max. 0.5 A) Max. current through the jumper in the connector: 20 A (15 A according to UL/CSA)
	+	Power supply	
	M	Ground	
	M	Ground	
Type: Screw terminal 2 (Page 336) Max. cross-section that can be connected: 2.5 mm <sup>2</sup>			

The maximum cable length that can be connected is 30 m.

#### Note

The two "+" or "M" terminals are jumpered in the connector. This ensures that the supply voltage is looped through.

This power supply is required for the digital outputs only.

The electronics power supply and the power supply for the analog inputs/outputs are taken from the option slot of the Control Unit.

#### Note

The power supply of the digital outputs and the electronics power supply of the Control Unit are isolated.

#### Note

If the 24 V supply is briefly interrupted, then the digital outputs are deactivated during this time.

4.4.2.3 X481 digital inputs/outputs

Table 4- 13 X481: Digital inputs/outputs

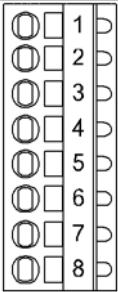
	Terminal	Designation <sup>1)</sup>	Technical data
	1	DI 0	Voltage: - 3 ... 30 V Current consumption, typical: 10 mA at 24 V DC Ground reference: X424.M Input delay: For "0" to "1": 20 µs for "1" to "0": 100 µs Signal level (including ripple) High level: 15 ... 30 V Low level: -3 ... 5 V
	2	DI 1	
	3	DI 2	
	4	DI 3	
	5	DO 0	Voltage: 24 V DC Max. load current per output: 500 mA Ground reference: X424.M Continuous short-circuit proof Output delay: For "0" to "1": typ. 150 µs at 0.5 A resistive load (500 µs maximum) For "1" to "0": Typically 50 µs at 0.5 A resistive load Switching frequency: for ohmic load: Max. 100 Hz For inductive load: Max. 0.5 Hz For lamp load: Max. 10 Hz Maximum lamp load: 5 W
	6	DO 1	
	7	DO 2	
	8	DO 3	
Type: Spring-loaded terminal 1 (Page 336) Max. cross-section that can be connected: 0.5 mm <sup>2</sup>			

<sup>1)</sup> DI: digital input, DO: digital output

**Note**

An open input is interpreted as "low".

The power supply and the digital inputs/outputs are isolated with respect to the Control Unit.

**Note**

If the 24 V supply is briefly interrupted, then the digital outputs are deactivated during this time.

#### 4.4.2.4 X482 analog inputs/outputs

Table 4- 14 X482: Analog inputs/outputs

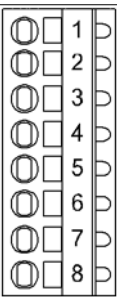
	Terminal	Designation <sup>1)</sup>	Technical data
	1	AI 0+	Analog inputs (AI) <b>Voltage:</b> -10 ... +10 V; R <sub>i</sub> : 65 kΩ <b>Common mode range:</b> ±30 V <b>Resolution:</b> 13 bits + sign
	2	AI 0-	
	3	AI 1+	
	4	AI 1-	
	5	AO 0+	Analog outputs (AO) <b>Voltage range:</b> -10 ... +10 V <b>Load current:</b> max. -3 ... +3 mA <b>Resolution:</b> 11 bit + signed Continuous short-circuit proof
	6	AO 0-	
	7	AO 1+	
	8	AO 1-	
Type: Spring-loaded terminal 1 (Page 336) Max. cross-section that can be connected: 0.5 mm <sup>2</sup>			

<sup>1)</sup> AI: analog input, AO: analog output

#### Note

##### Permissible voltage values

In order to avoid incorrect results of the analog-digital conversion, the analog differential voltage signals can have a maximum offset voltage of ±30 V with respect to ground potential.

#### Note

An open input is interpreted as approximately "0 V".

The power supply of the analog inputs/outputs is taken from the option slot of the Control Unit and not from X424.

The shield is connected to the Control Unit (see Shield support (Page 104)).

#### Connecting the analog inputs

Additional information about the analog inputs can be taken from the following reference:  
 Reference: /IH1/ SINAMICS S120 Commissioning Manual

### 4.4.3 Connection example

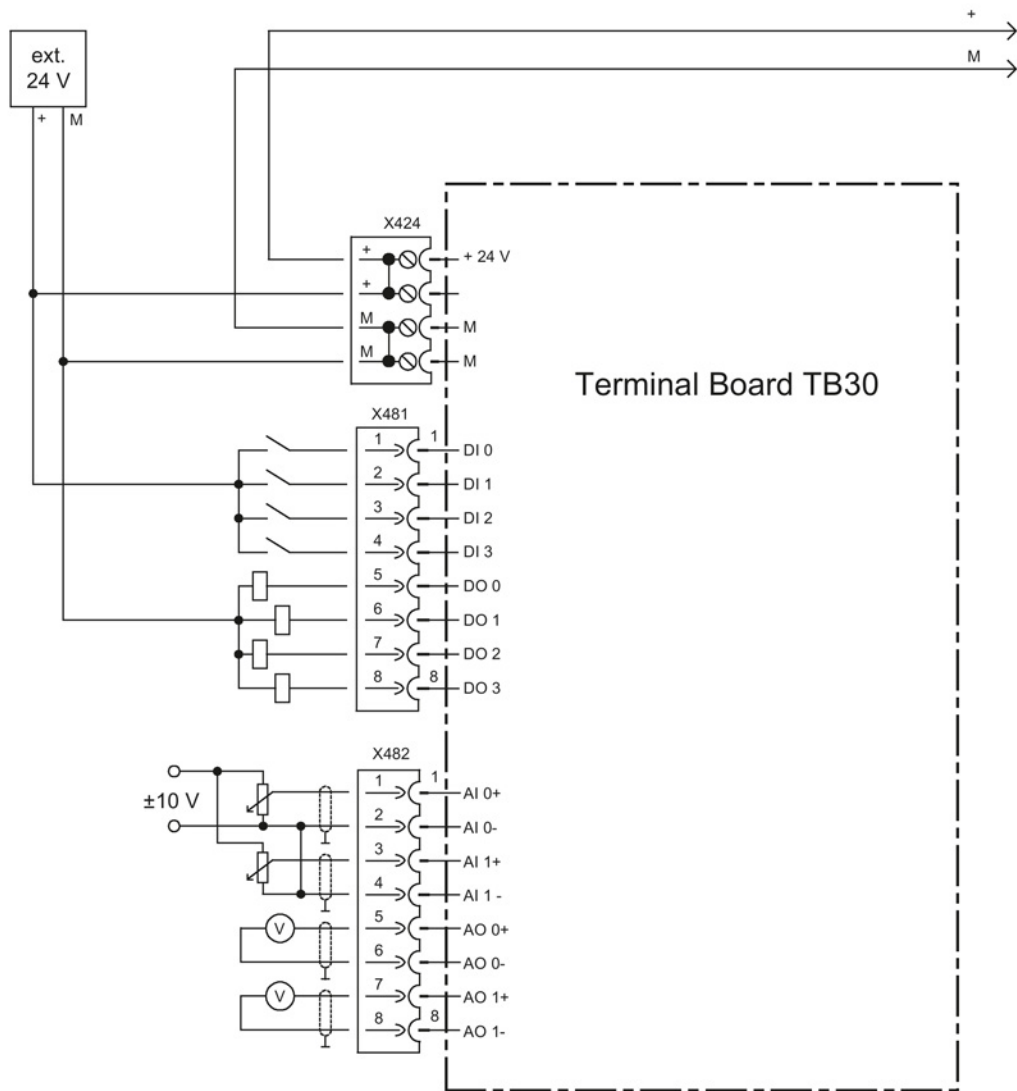

Figure 4-7 Example connection of TB30

#### 4.4.4 Installation

1. Release the screws and remove the protective cover from the Control Unit.
2. Place the Option Board into the slot on the Control Unit and fix it in place using the screws.

**Screws:** M3

**Tool:** Torx T10 screwdriver

**Tightening torque:** 0.8 Nm

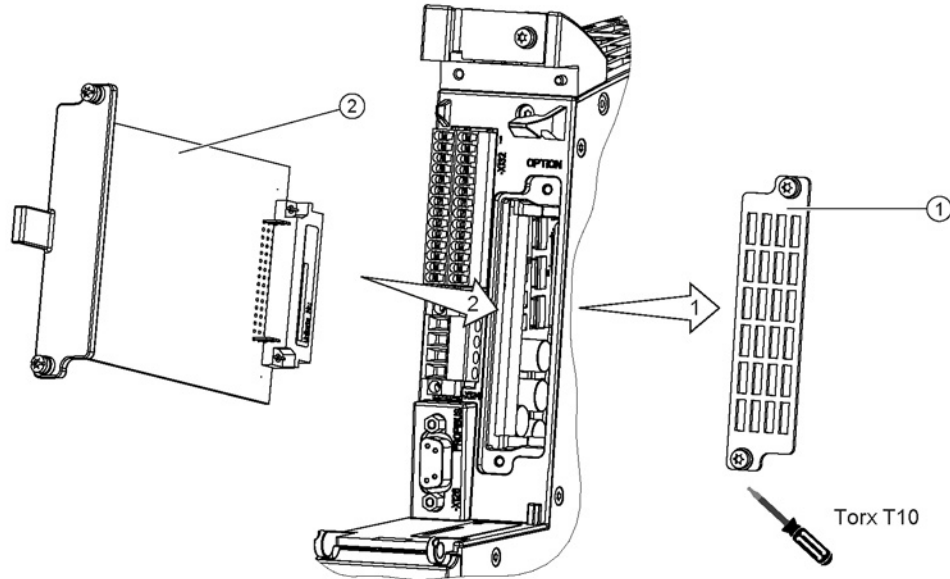

- ① Protective cover
- ② Option Board

Figure 4-8 Installing an Option Board using a CU320-2 DP as an example

### 4.4.5 Shield support

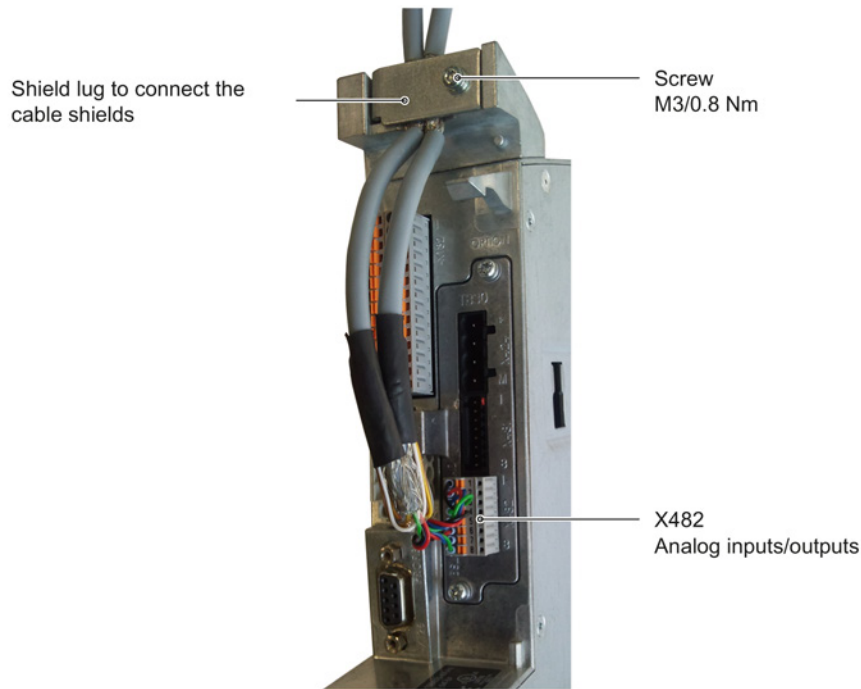

Figure 4-9 Shield support for TB30 on the CU320-2 DP

The permissible bending radii for the cables must not be exceeded when the cables are being installed.

### 4.4.6 Technical data

Table 4- 15 Technical data

Terminal Board TB30 3SL3055-0AA00-2TAx	Unit	Value
<b>Electronics power supply</b>		
Voltage	V <sub>DC</sub>	24 (20.4 ... 28.8)
Current via the option slot of the CU (without digital outputs)	A <sub>DC</sub>	0.05
Power loss	W	<3
Max. cable length	m	30
Response time	The response time of the digital input/outputs and the analog inputs/outputs depends on the evaluation on the Control Unit (see function diagram). Additional information can be taken from the following references: Reference: /LH1/ SINAMICS S120/S150 List Manual, Chapter "Function diagrams/Terminal Board TB30"	
Weight	kg	0.1



# Terminal Modules

## 5.1 Safety instructions for Terminal Modules

 <b>WARNING</b>
<b>Danger to life if the fundamental safety instructions and remaining risks are not carefully observed</b>
If the fundamental safety instructions and remaining risks in Chapter 1 (Page 19) are not observed, accidents involving severe injuries or death may occur.
<ul style="list-style-type: none"><li>• Adhere to the fundamental safety instructions.</li><li>• When assessing the risk, take into account remaining risks.</li></ul>

 <b>WARNING</b>
<b>Risk of fire through overheating if there are insufficient ventilation clearances</b>
Insufficient ventilation clearances lead to overheating with associated risk to persons as a result of smoke and fire. This can also result in more downtimes and reduced service lives of the Terminal Module.
<ul style="list-style-type: none"><li>• For this reason, it is imperative that you maintain the 50 mm clearances above and below the Terminal Module.</li></ul>

<b>NOTICE</b>
<b>Device failure as a result of unshielded or incorrectly routed cables to temperature sensors</b>
Unshielded or incorrectly routed cables to temperature sensors can result in interference being coupled into the signal processing electronics from the power side. This can result in significant disturbance of all signals (fault messages) up to failure of individual components (destruction of the devices).
<ul style="list-style-type: none"><li>• Only use shielded cables as temperature sensor cables.</li><li>• If temperature sensor cables are routed together with the motor cable, use separately shielded cables twisted in pairs.</li><li>• Connect the cable shield at both ends to ground potential through a large surface area.</li><li>• Recommendation: Use suitable Motion Connect cables.</li></ul>

**NOTICE****Damage through use of incorrect DRIVE-CLiQ cables**

Damage or malfunctions can occur on the devices or system when incorrect or unreleased DRIVE-CLiQ cables are used.

- Only use suitable DRIVE-CLiQ cables that have been released by Siemens for the respective application.

**Note****Malfunctions due to polluted DRIVE-CLiQ interfaces**

Malfunctions can occur in the system through the use of polluted DRIVE-CLiQ interfaces.

- Cover unused DRIVE-CLiQ interfaces with the supplied blanking covers.

**Note****Function equipotential bonding for distributed DRIVE-CLiQ nodes**

Integrate all of the components that are connected via DRIVE-CLiQ in the functional equipotential bonding concept. The connection should be preferably established by mounting on metallic bare machine and plant components that are connected with one another using an equipotential bonding conductor.

Alternatively, you can establish equipotential bonding using a conductor (min. 6 mm<sup>2</sup>), which as far as possible, is routed in parallel to the DRIVE-CLiQ cable. All distributed DRIVE-CLiQ nodes are involved, for example DMx20, SME2x, SM12x etc.

## 5.2 Terminal Module TM15

### 5.2.1 Description

The Terminal Module TM15 is a terminal expansion for snapping on to an EN 60715 DIN rail. The TM15 can be used to increase the number of available digital inputs/outputs within a drive system.

Table 5- 1 Interface overview of the TM15

Type	Quantity
DRIVE-CLiQ interfaces	2
Bidirectional digital inputs/outputs	24 (isolation in 3 groups each with 8 DI/DO)

## 5.2.2 Interface description

### 5.2.2.1 Overview

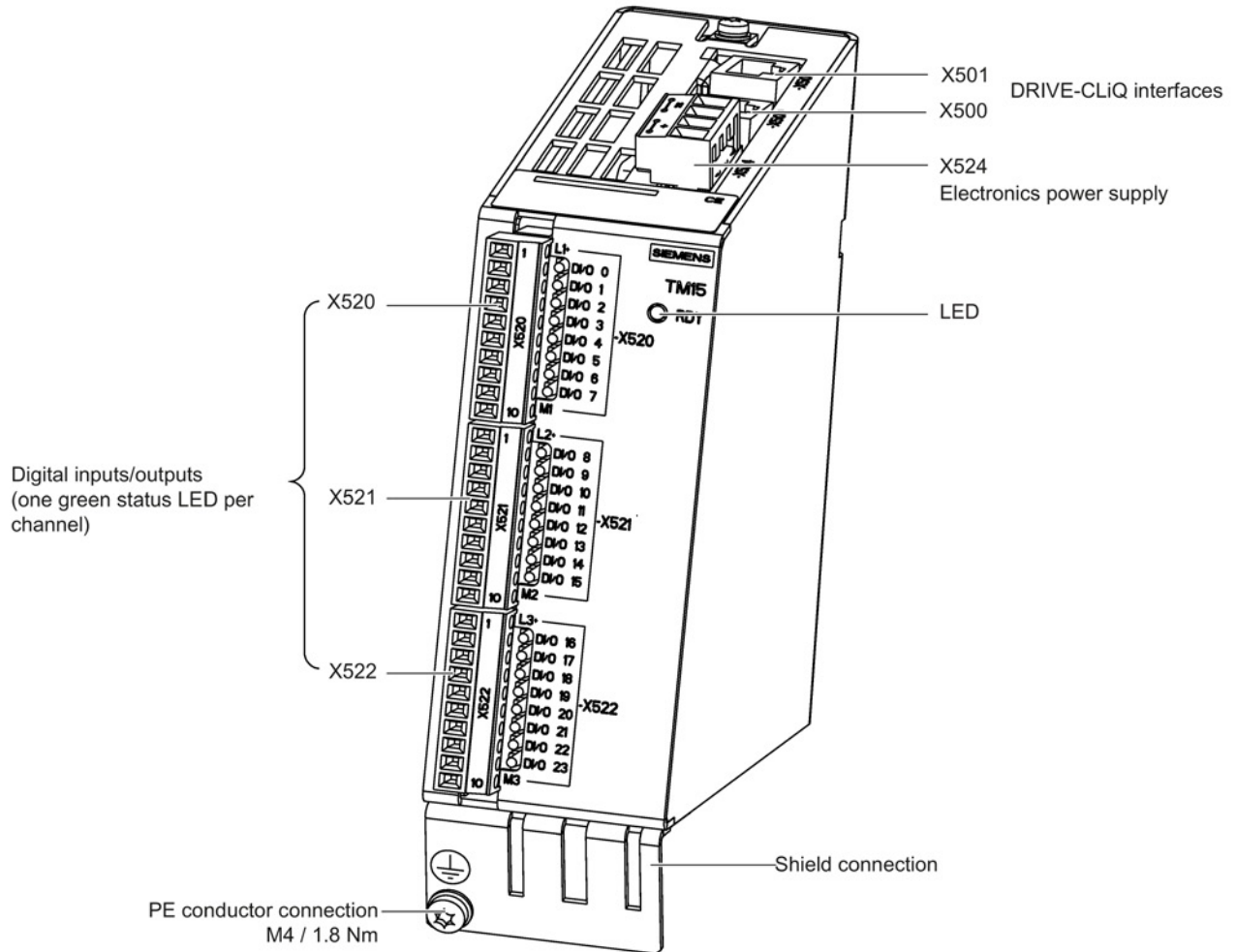
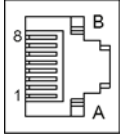

Figure 5-1 TM15 interface overview

5.2.2.2 X500/X501 DRIVE-CLiQ interfaces

Table 5- 2 X500/X501: DRIVE-CLiQ interfaces

	Pin	Signal name	Technical data
	1	TXP	Transmit data +
	2	TXN	Transmit data -
	3	RXP	Receive data +
	4	Reserved, do not use	
	5	Reserved, do not use	
	6	RXN	Receive data -
	7	Reserved, do not use	
	8	Reserved, do not use	
	A	+ (24 V)	Power supply
	B	M (0 V)	Electronics ground

The blanking covers for the DRIVE-CLiQ interfaces are included in the scope of delivery.

Blanking covers (50 x) Article No.: 6SL3066-4CA00-0AA0

**Note**

The maximum DRIVE-CLiQ cable length is 100 m.

### 5.2.2.3 X520 bidirectional digital inputs/outputs

Table 5- 3 X520: Digital inputs/outputs

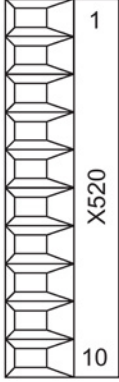
	Terminal	Designation <sup>1)</sup>	Technical data
	1	L1+	See Chapter, Technical data (Page 118).
	2	DI/DO 0	
	3	DI/DO 1	
	4	DI/DO 2	
	5	DI/DO 3	
	6	DI/DO 4	
	7	DI/DO 5	
	8	DI/DO 6	
	9	DI/DO 7	
	10	M1 (GND)	
Type: Screw terminal 1 (Page 336) Max. cross-section that can be connected: 1.5 mm <sup>2</sup>			

- <sup>1)</sup> L1+: A 24 V DC power supply for DI/DO 0 to 7 (first potential group) must always be connected if at least one DI/DO of the potential group is used as output.  
 M1: A ground reference for DI/DO 0 to 7 (first potential group) must always be connected if at least one DI/DO of the potential group is used as either input or output.  
 DI/DO: bidirectional digital input/output

5.2.2.4 X521 bidirectional digital inputs/outputs

Table 5- 4 X521: Digital inputs/outputs

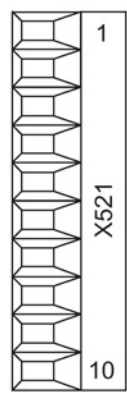
	Terminal	Designation <sup>1)</sup>	Technical data
	1	L2+	See Chapter, Technical data (Page 118).
	2	DI/DO 8	
	3	DI/DO 9	
	4	DI/DO 10	
	5	DI/DO 11	
	6	DI/DO 12	
	7	DI/DO 13	
	8	DI/DO 14	
	9	DI/DO 15	
	10	M2 (GND)	
Type: Screw terminal 1 (Page 336) Max. cross-section that can be connected: 1.5 mm <sup>2</sup>			

- 1) L2+: A 24 V DC power supply for DI/DO 8 to 15 (second potential group) must always be connected if at least one DI/DO of the potential group is used as output.  
 M2: A ground reference for DI/DO 8 to 15 (second potential group) must always be connected if at least one DI/DO of the potential group is used as either input or output.  
 DI/DO: bidirectional digital input/output

### 5.2.2.5 X522 bidirectional digital inputs/outputs

Table 5- 5 X522: Digital inputs/outputs

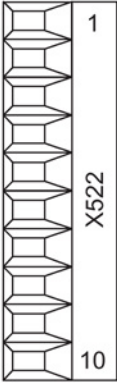
	Terminal	Designation <sup>1)</sup>	Technical data
	1	L3+	See Chapter, Technical data (Page 118).
	2	DI/DO 16	
	3	DI/DO 17	
	4	DI/DO 18	
	5	DI/DO 19	
	6	DI/DO 20	
	7	DI/DO 21	
	8	DI/DO 22	
	9	DI/DO 23	
	10	M3 (GND)	
Type: Screw terminal 1 (Page 336) Max. cross-section that can be connected: 1.5 mm <sup>2</sup>			

- <sup>1)</sup> L3+: A 24 V DC power supply for DI/DO 16 to 23 (third potential group) must always be connected if at least one DI/DO of the potential group is used as output.  
M3: A ground reference for DI/DO 16 to 23 (third potential group) must always be connected if at least one DI/DO of the potential group is used as either input or output.  
DI/DO: Bidirectional digital input/output

### 5.2.2.6 X524 Electronics power supply

Table 5- 6 X524: Electronics power supply

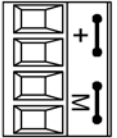
	Terminal	Designation	Technical data
	+	Electronics power supply	Voltage: 24 V DC (20.4 ... 28.8 V) Current consumption: max. 0.6 A <sup>1)</sup> Max. current through the jumper in the connector: 20 A (15 A according to UL/CSA)
	+	Electronics power supply	
	M	Electronics ground	
	M	Electronics ground	
Type: Screw terminal 2 (Page 336)			

- <sup>1)</sup> Including the current consumption for the digital outputs  
The maximum cable length that can be connected is 30 m.

#### Note

The two "+" or "M" terminals are jumpered in the connector. This ensures that the supply voltage is looped through.

The current consumption increases by the value for the DRIVE-CLiQ participants.  
The digital outputs are supplied via terminals X520, X521 and X522.

5.2.3 Connection example

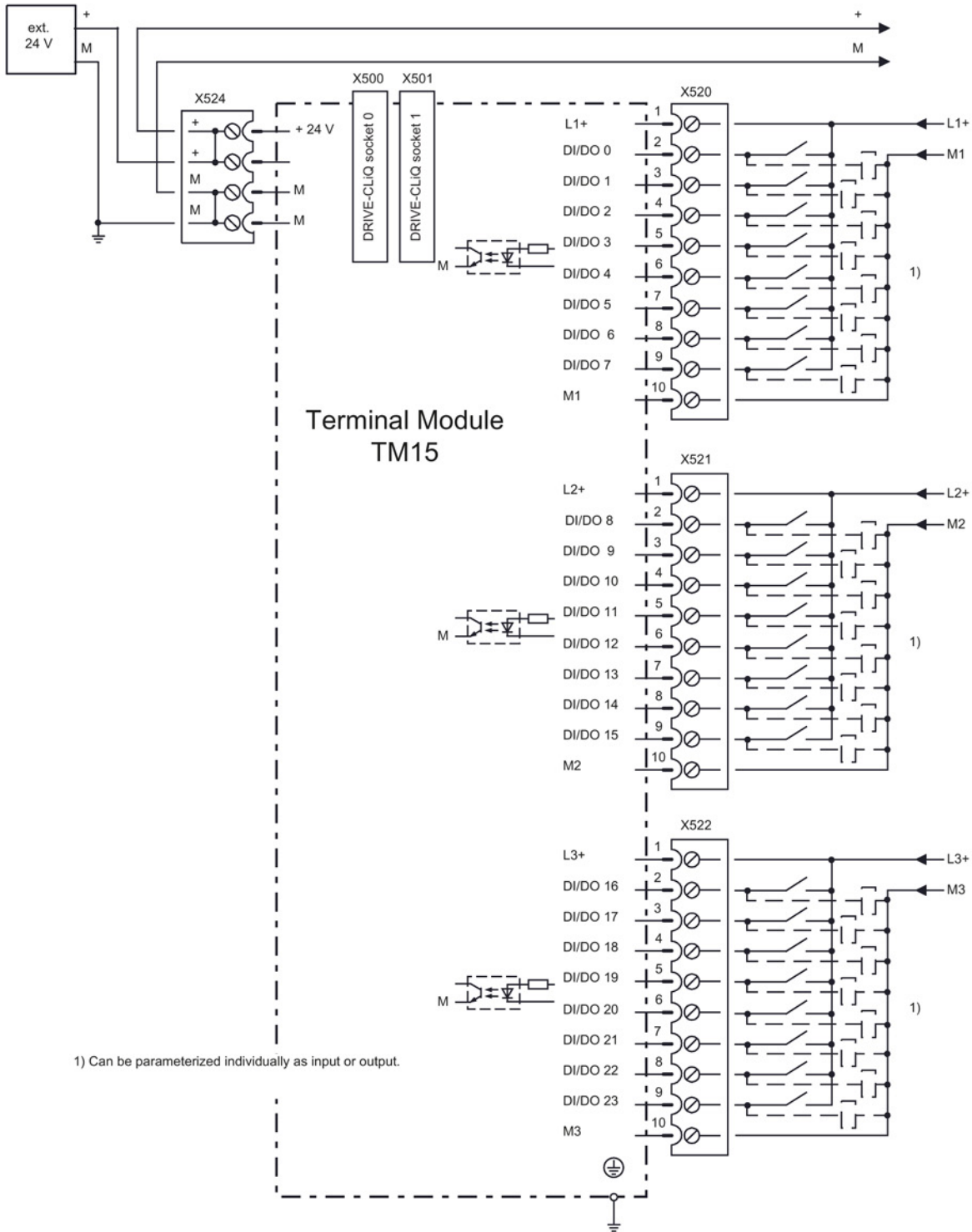

Figure 5-2 Example connection of TM15



## 5.2.4 Meaning of the LED

Table 5- 7 Meanings of the LEDs on the Terminal Module TM15

LED	Color	Status	Description, cause	Remedy	
READY	-	Off	The electronics power supply is missing or outside the permissible tolerance range.	-	
	Green	Continuous light	The component is ready for operation. Cyclic DRIVE-CLiQ communication is taking place.	-	
	Orange	Continuous light	DRIVE-CLiQ communication is being established.	-	
	Red	Continuous light	This component has at least one fault. <b>Note:</b> The LED is activated regardless of whether the corresponding messages have been reconfigured.	Remove and acknowledge the fault.	
	Green/red	Flashing light 0.5 Hz	Flashing light 0.5 Hz	Firmware is being downloaded.	-
			Flashing light 2 Hz	Firmware download is complete. The system waits for POWER ON.	Carry out a POWER ON.
	Green/orange or Red/orange	Flashing light	Component recognition via LED is activated <sup>1)</sup> . <b>Note:</b> Both options depend on the LED status when component recognition is activated.	-	

<sup>1)</sup> The parameters for activating component recognition using LEDs can be taken from the following reference:  
Reference: /LH1/ SINAMICS S120/S150 List Manual

### Cause and rectification of faults

Additional information about the cause and resolving faults can be taken from the following references:

- Reference: /LH1/SINAMICS S120/S150 List Manual
- Reference: /IH1/ SINAMICS S120 Commissioning Manual

### 5.2.5 Dimension drawing

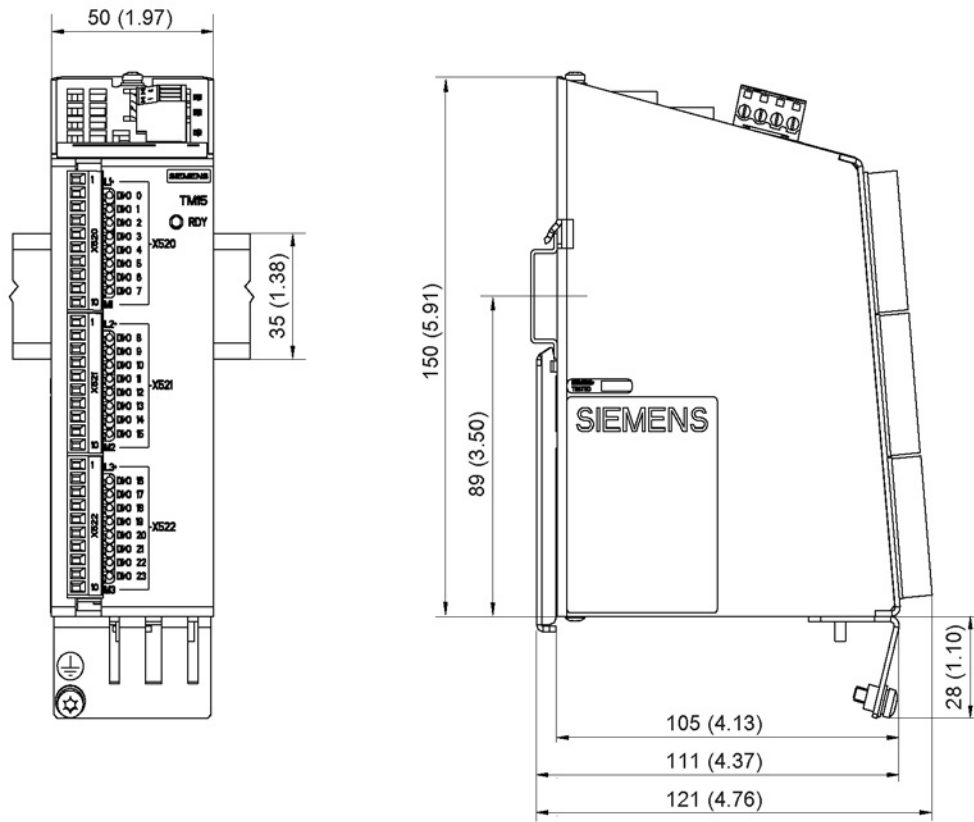

Figure 5-3 Dimension drawing of Terminal Module TM15, all data in mm and (inches)

## 5.2.6 Installation

### Installation

1. Tilt the component backwards slightly and attach it to the DIN rail using the hooks.
2. Swivel the component onto the DIN rail until you hear the mounting slide at the rear latch into position.
3. Slide the component along the mounting rail to either the left or the right into its final position.

### Removal

1. First shift the mounting slide downwards at the lug to release the interlocking with the mounting rail.
2. Swivel the component to the front and withdraw it upwards from the DIN rail.

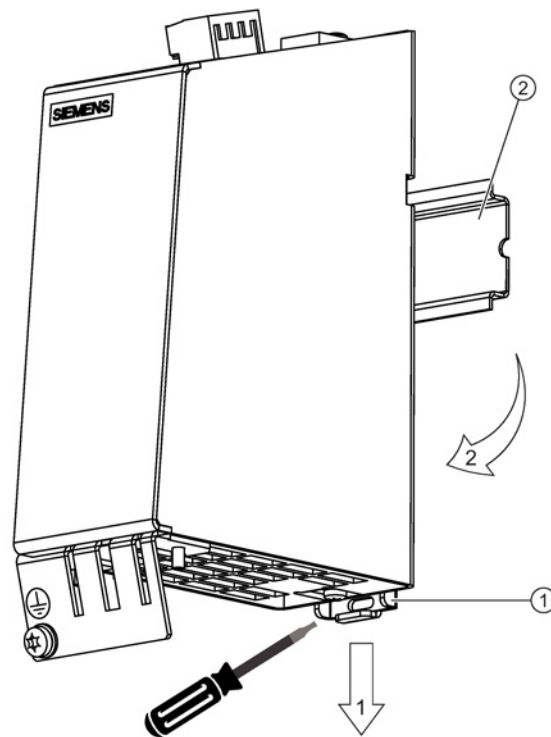

- ① Mounting slide
- ② Mounting rail

Figure 5-4 Removing from a DIN mounting rail

### 5.2.7 Protective conductor connection and shield support

It is always advisable to shield the digital input/output wiring.

The following diagram shows a typical Weidmüller shield connection clamp for the shield supports.

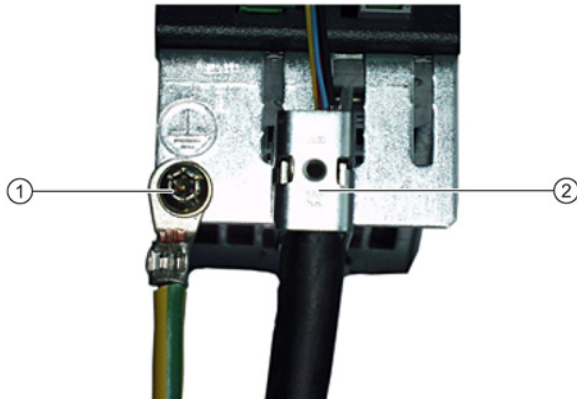

- ① Protective conductor connection M4 / 1.8 Nm
- ② Shield connection terminal, Weidmüller, type: KLBÜ CO1, Article No.: 1753311001

Figure 5-5 Shield support and protective conductor connection

#### NOTICE

##### Damage or faulty operation due to incorrect shielding or inadmissible cable lengths

If the correct shielding procedures or the permissible cable lengths are not observed, it can cause damage or the machine may malfunction.

- Only use shielded cables.
- Do not exceed the cable lengths stated in the technical data.

The TM15 housing is connected to the ground terminal of the module supply (terminal X524). If the ground terminal is actually grounded, then the housing is also grounded. An additional ground connection using the M4 screw is especially necessary if high potential bonding currents can flow (e.g. through the cable shield).

## 5.2.8 Connector coding

A series of coding elements ("coding sliders") are supplied with each Terminal Module TM15.

### Connector coding

1. Insert at least one coding slider at the required position.
2. Remove the associated coding lug at the connector.

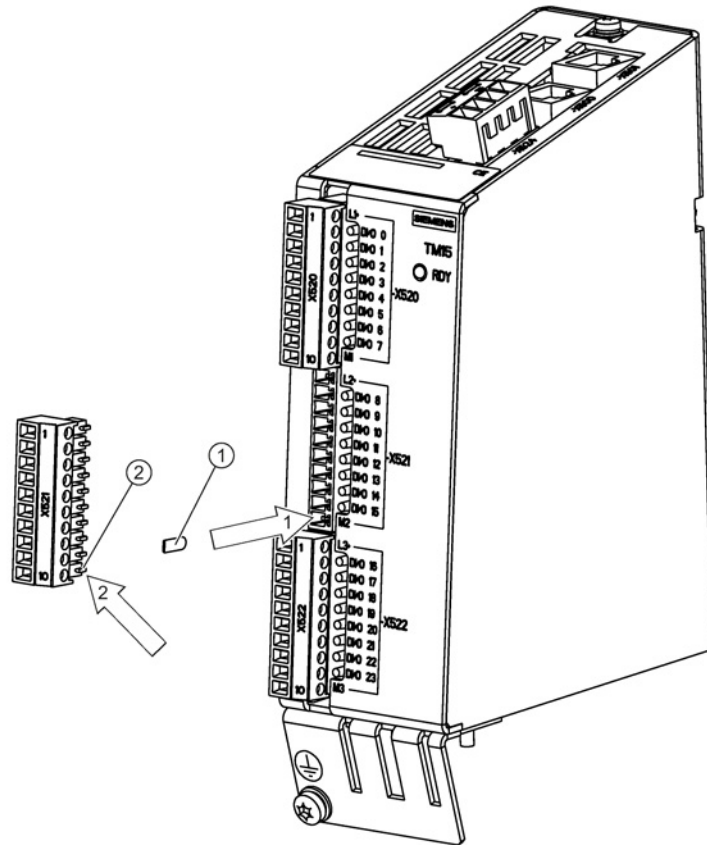

- ① Coding slider
- ② Coding lug at the connector to be removed

Figure 5-6 Connector coding using the example of interface X521

To avoid wiring errors, unique coding patterns must be defined for the connectors X520, X521 and X522.

Possible patterns:

- 3 connectors on one component are encoded differently (i.e. X520, X521 and X522).
- Different component types are encoded differently.
- Identical components on the same machine are encoded differently, e.g. several TM15-type components.

## 5.2.9 Technical data

Table 5- 8 Technical data

6SL3055-0AA00-3FAx	Unit	Value
<b>Electronics power supply</b>		
Voltage	V <sub>DC</sub>	24 (20.4 ... 28.8)
Current (without DRIVE-CLiQ or digital outputs)	A <sub>DC</sub>	0.15
Power loss	W	< 3
Max. cable length	m	30
<b>I/O</b>		
Digital inputs/outputs	Can either be parameterized as DI or DO	
Number of digital inputs/outputs	24	
Electrical isolation	Yes, in groups of 8	
Max. cable length	m	30
<b>Digital inputs</b>		
Voltage	V <sub>DC</sub>	-30 ... +30
Low-level (an open digital input is interpreted as "low")	V <sub>DC</sub>	-30 ... +5
High level	V <sub>DC</sub>	15 ... 30
Input Impedance	kΩ	2.8
Current consumption (at 24 V DC)	mA	11
Max. voltage in the OFF state	V <sub>DC</sub>	5
Current in OFF state	mA	0.0 ... 1.0 (per channel)
Typical input delay of the digital inputs	μs	"0" → "1": 50 "1" → "0": 100
<b>Digital outputs (continued-short-circuit-proof)</b>		
Voltage	V <sub>DC</sub>	24
Max. load current per digital output	A <sub>DC</sub>	0.5
Output delay (resistive load)		
Typical	μs	"0" → "1": 50 "1" → "0": 150
Maximum	μs	"0" → "1": 100 "1" → "0": 225
Min. output pulse (100% amplitude, 0.5 A with resistive load)	μs	125 (typ.) 350 (max.)
Switching frequency		
For resistive load	Hz	Max. 100
For inductive load	Hz	Max. 0.5
For lamp load	Hz	Max. 10
Maximum lamp load	W	5
Max. switching frequency (100 % amplitude, load cycle 50 % / 50 %; for 0.5 A and resistive load)	kHz	1 (typ.)
Voltage drop in ON state	V <sub>DC</sub>	0.75 (max.) for maximum load in all circuits
Leakage current in OFF state	μA	Max. 10 per channel

6SL3055-0AA00-3FAx	Unit	Value
Voltage drop, output (I/O power supply to the output)	V <sub>DC</sub>	0.5
Max. total current of outputs (per group) up to 60°C up to 50°C up to 40°C	A <sub>DC</sub> A <sub>DC</sub> A <sub>DC</sub>	2 3 4
Response time	<p>The response time of the digital inputs/outputs comprises the following:</p> <ul style="list-style-type: none"> <li>• Response time on the component itself (approx. 1/2 DRIVE-CLiQ cycle).</li> <li>• Transfer time via the DRIVE-CLiQ connection (approx. 1 DRIVE-CLiQ cycle).</li> <li>• Evaluation on the Control Unit (see function diagram)</li> </ul> <p>Additional information can be taken from the following references: Reference: /LH1/ SINAMICS S120/S150 List Manual, Chapter "Function diagrams/Terminal Module 15"</p>	
PE/ground connection	At the housing with M4/1.8 Nm screw	
Weight	kg	0.86
Degree of protection	IP20	

## 5.3 Terminal Module TM31

### 5.3.1 Description

The Terminal Module TM31 is a terminal expansion that is snapped onto a EN 60715 standard mounting rail. Terminal Module TM31 can be used to increase the number of available digital inputs/digital outputs and also the number of analog inputs/analog outputs within a drive system.

The TM31 contains the following interfaces:

Table 5- 9 Interface overview of the TM31

Type	Quantity
DRIVE-CLiQ interfaces	2
Digital inputs	8
Bidirectional digital inputs/outputs	4
Analog inputs	2
Analog outputs	2
Relay outputs	2
Temperature sensor input	1

### 5.3.2 Interface description

#### 5.3.2.1 Overview

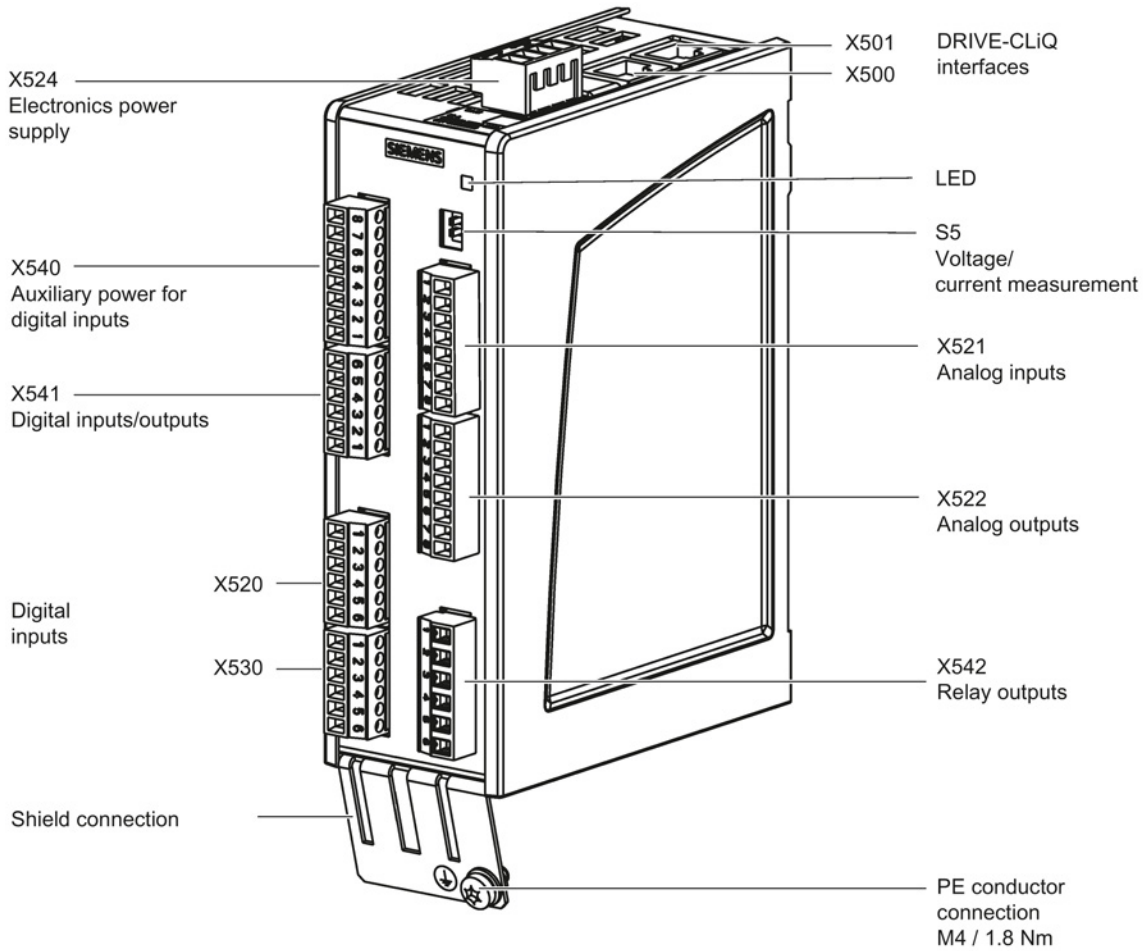
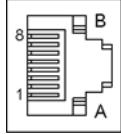

Figure 5-7 Interface overview TM31



### 5.3.2.2 X500/X501 DRIVE-CLiQ interfaces

Table 5- 10 X500/X501: DRIVE-CLiQ interfaces

	Pin	Signal name	Technical data
	1	TXP	Transmit data +
	2	TXN	Transmit data -
	3	RXP	Receive data +
	4	Reserved, do not use	
	5	Reserved, do not use	
	6	RXN	Receive data -
	7	Reserved, do not use	
	8	Reserved, do not use	
	A	+ (24 V)	Power supply
	B	M (0 V)	Electronics ground

The blanking covers for the DRIVE-CLiQ interfaces are included in the scope of delivery.

Blanking covers (50 x) Article No.: 6SL3066-4CA00-0AA0

#### Note

The maximum DRIVE-CLiQ cable length is 100 m.

### 5.3.2.3 X520 digital inputs

Table 5- 11 X520: Digital inputs

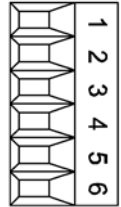
	Terminal	Designation <sup>1)</sup>	Technical data
	1	DI 0	<b>Voltage:</b> - 3 ... +30 V <b>Current consumption</b> typical: 10 mA at 24 V DC <b>Input delay:</b> for "0" to "1": Typ. 50 µs max. 100 µs for "1" to "0": Typ. 130 µs, max. 150 µs <b>Electrical isolation:</b> Reference potential is terminal M1 <b>Signal level</b> (including ripple) High level: 15 ... 30 V Low level: -3 ... +5 V
	2	DI 1	
	3	DI 2	
	4	DI 3	
	5	M1	
	6	M	

Type: Screw terminal 1 (Page 336)  
Max. cross-section that can be connected: 1.5 mm<sup>2</sup>

<sup>1)</sup> DI: Digital input; M: Electronics ground; M1: Ground reference

**Note****Ensuring the function of digital inputs**

An open input is interpreted as "low".

Terminal M1 must be connected so that the digital inputs (DI) can function.

This is achieved by using one of the following measures:

1. Providing the ground reference of the digital inputs
2. A jumper to terminal M

**Note:** This removes isolation for these digital inputs.

### 5.3.2.4 X521 analog inputs

Table 5- 12 X521: Analog inputs

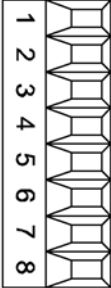
	Terminal	Designation <sup>1)</sup>	Technical data
	1	AI 0+	The analog inputs can be toggled between current and voltage input using switches S5.0 and S5.1.  <b>As voltage input:</b> -10 ... +10 V; R <sub>i</sub> > 100 kΩ Resolution: 11 bits + sign  <b>As current input:</b> -20 ... +20 mA; R <sub>i</sub> = 250 kΩ Resolution: 10 bits + sign
	2	AI 0-	
	3	AI 1+	
	4	AI 1-	
	5	P10	<b>Auxiliary voltage:</b> P10 = 10 V N10 = -10 V Current-carrying capacity: max. 3 mA Continuously short-circuit proof
	6	M	
	7	N10	
	8	M	
Type: Screw terminal 1 (Page 336) Max. cross-section that can be connected: 1.5 mm <sup>2</sup>			

<sup>1)</sup> AI: analog inputs; P10/N10: auxiliary voltage; M or GND: ground reference

**NOTICE**

**Damage or malfunctions through impermissible voltage values**

If a current exceeding  $\pm 35$  mA flows through the analog current input, then the component could be destroyed.

The common mode range must not be violated in order to avoid incorrect analog-digital conversion results.

- The input voltage may only be in the range between -30 V and +30 V (destruction limit).
- The common mode voltage may only be in the range between -10 V and +10 V (error limit).
- The back EMF at the auxiliary voltage connections may only be in the range between -15 V and +15 V.

**Note**

The power supply for the analog inputs can be taken internally or from an external power supply unit

### 5.3.2.5 S5 current/voltage changeover switch for analog inputs

Table 5- 13 Current/voltage selector S5

	Switch	Function
	S5.0	Selector voltage (V)/current (I) AI0
	S5.1	Selector voltage (V)/current (I) AI1

## 5.3.2.6 X522 analog outputs/temperature sensor

Table 5- 14 X522: Analog outputs/temperature sensor

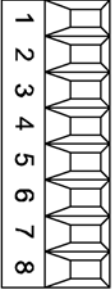
	Terminal	Designation <sup>1)</sup>	Technical data
	1	AO 0V+	You can set the following output signals using parameters: <b>Voltage:</b> -10 ... +10 V (max. 3 mA) <b>Current 1:</b> 4 ... 20 mA (max. load resistance $\leq 500 \Omega$ ) <b>Current 2:</b> -20 ... +20 mA (max. load resistance $\leq 500 \Omega$ ) <b>Current 3:</b> 0 ... 20 mA (max. load resistance $\leq 500 \Omega$ ) Resolution: 11 bits + sign Continuously short-circuit proof
	2	AO 0-	
	3	AO 0C+	
	4	AO 1V+	
	5	AO 1-	
	6	AO 1C+	
	7	+ Temp	Temperature sensor KTY84-1C130/PTC Measuring current via temperature sensor connection: 2 mA
	8	- Temp	

Type: Screw terminal 1 (Page 336)  
 Max. cross-section that can be connected: 1.5 mm<sup>2</sup>

<sup>1)</sup> AO xV: analog output voltage; AO xC: analog output current

**NOTICE****Damage or malfunctions through impermissible voltage values**

If the back EMF is impermissible then damage and malfunctions may occur on the components.

- The back EMF at the outputs may only be in the range between -15 V and +15 V.

**NOTICE****Damage to motor in the event of incorrectly connected KTY temperature sensor**

If a KTY temperature sensor is connected with incorrect polarity, it is not possible to detect when the motor overheats. Overheating can cause damage to the motor.

- Connect a KTY temperature sensor with the correct polarity.

**! WARNING****Danger to life due to electric shock in the event of voltage flashovers at the temperature sensor**

Voltage flashovers in the signal electronics can occur in motors without safe electrical separation of the temperature sensors.

- Use temperature sensors that comply with the specifications regarding safe electrical separation.
- If safe electrical separation cannot be guaranteed (for linear motors or third-party motors, for example), use a Sensor Module External (SME120 or SME125) or Terminal Module TM120.

### 5.3.2.7 X524 Electronics power supply

Table 5- 15 X524: Electronics power supply

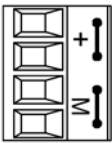
	Terminal	Designation	Technical data
	+	Electronics power supply	Voltage: 24 V DC (20.4 ... 28.8 V) Current consumption: max. 1.7 A <sup>1)</sup>  Max. current through the jumper in the connector: 20 A (15 A according to UL/CSA)
	+	Electronics power supply	
	M	Electronics ground	
	M	Electronics ground	
Type: Screw terminal 2 (Page 336)			

<sup>1)</sup> Including the current consumption for the digital outputs and for supplying the sensor  
The maximum cable length that can be connected is 30 m.

#### Note

The two "+" or "M" terminals are jumpered in the connector. This ensures that the supply voltage is looped through.

The current consumption increases by the value for the DRIVE-CLiQ node and digital outputs.

### 5.3.2.8 X530 digital inputs

Table 5- 16 X530: Digital inputs

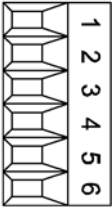
	Terminal	Designation <sup>1)</sup>	Technical data
	1	DI 4	<b>Voltage:</b> -3 ... +30 V <b>Current consumption</b> typical: 10 mA at 24 V DC <b>Input delay:</b> for "0" to "1": Typ. 50 µs max. 100 µs for "1" to "0": typ. 130 µs, max. 150 µs <b>Electrical isolation:</b> Reference potential is terminal M2 <b>Level</b> (including ripple): High level: 15 ... 30 V Low level: -3 ... +5 V
	2	DI 5	
	3	DI 6	
	4	DI 7	
	5	M2	
	6	M	
Type: Screw terminal 1 (Page 336) Max. cross-section that can be connected: 1.5 mm <sup>2</sup>			

<sup>1)</sup> DI: digital input; M: electronics ground; M2: ground reference

**Note****Ensuring the function of digital inputs**

An open input is interpreted as "low".

To enable the digital inputs (DI) to function, terminal M2 must be connected.

This is achieved by using one of the following measures:

1. Providing the ground reference of the digital inputs
2. A jumper to terminal M

**Note:** This removes isolation for these digital inputs.

### 5.3.2.9 X540 auxiliary voltage for the digital inputs

Table 5- 17 X540: Auxiliary voltage for digital inputs

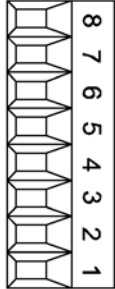
	Terminal	Designation	Technical data
	8	+24 V	Voltage: +24 V DC Max. total load current of +24 V auxiliary voltage for terminals X540 and X541 combined: 150 mA
	7	+24 V	
	6	+24 V	
	5	+24 V	
	4	+24 V	
	3	+24 V	
	2	+24 V	
	1	+24 V	
Type: Screw terminal 1 (Page 336) Max. cross-section that can be connected: 1.5 mm <sup>2</sup>			

**Note**

This voltage supply is only for powering the digital inputs.

**Note**

If the 24 V supply is briefly interrupted, the auxiliary voltage for the digital inputs is deactivated for this time.

### 5.3.2.10 X541 bidirectional digital inputs/outputs

Table 5- 18 X541: Bidirectional digital inputs/outputs

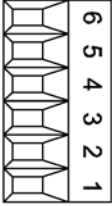
	Terminal	Designation <sup>1)</sup>	Technical data
	6	M	<b>Auxiliary voltage:</b> Voltage: +24 V DC Max. total load current of +24 V auxiliary voltage of terminals X540 and X541 combined: 150 mA  <b>As input:</b> Voltage: -3 ... 30 V Current consumption, typical: 10 mA at 24 V Input delay: for "0" to "1": Typ. 50 µs for "1" to "0": Typ. 100 µs  <b>As output:</b> Voltage: 24 V DC Max. load current per output: 500 mA Max. total current of outputs (including currents to the inputs): 100 mA / 1 A (can be parameterized) Continuously short-circuit proof Output delay: for "0" to "1": typ. 150 µs at 0.5 A resistive load (500 µs maximum) for "1" to "0": Typically 50 µs at 0.5 A resistive load Switching frequency: for ohmic load: Max. 100 Hz For inductive load: Max. 0.5 Hz For lamp load: Max. 10 Hz Maximum lamp load: 5 W
	5	DI/DO 11	
	4	DI/DO 10	
	3	DI/DO 9	
	2	DI/DO 8	
	1	+24 V	
Type: Screw terminal 1 (Page 336) Max. cross-section that can be connected: 1.5 mm <sup>2</sup>			

<sup>1)</sup> DI/DO: Bidirectional digital input/output; M: Electronics ground

---

**Note**

An open input is interpreted as "low".

---

**Note**

If the 24 V supply is briefly interrupted, then the digital outputs are deactivated during this time.

---

## 5.3.2.11 X542 relay outputs

Table 5- 19 X542: Relay outputs

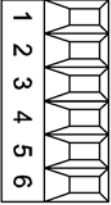
	Terminal	Designation <sup>1)</sup>	Technical data
	1	DO 0.NC	Contact type: Two-way contact max. load current: 8 A Max. switching voltage: 250 V <sub>AC</sub> , 30 V <sub>DC</sub> Max. switching power at 250 V <sub>AC</sub> : 2000 VA (cosφ = 1) Max. switching power at 250 V <sub>AC</sub> : 750 VA (cosφ = 0.4) Max. switching power at 30 V <sub>DC</sub> : 240 W (resistive load) Required minimum current: 100 mA Output delay: ≤ 20 ms <sup>2)</sup> Overvoltage category: Class II acc. to EN 60664-1
	2	DO 0.COM	
	3	DO 0.NO	
	4	DO 1.NC	
	5	DO 1.COM	
	6	DO 1.NO	

Type: Screw terminal 3 (Page 336)

Maximum connectable cross-section: 2.5 mm<sup>2</sup>

Maximum switching frequency at full load: 6 rpm

<sup>1)</sup> DO: digital output, NO: normally-open contact, NC: normally-closed contact, COM: mid-position contact

<sup>2)</sup> Depending on the parameterization and the supply voltage (P24) of the TM31



### 5.3.3 Connection example

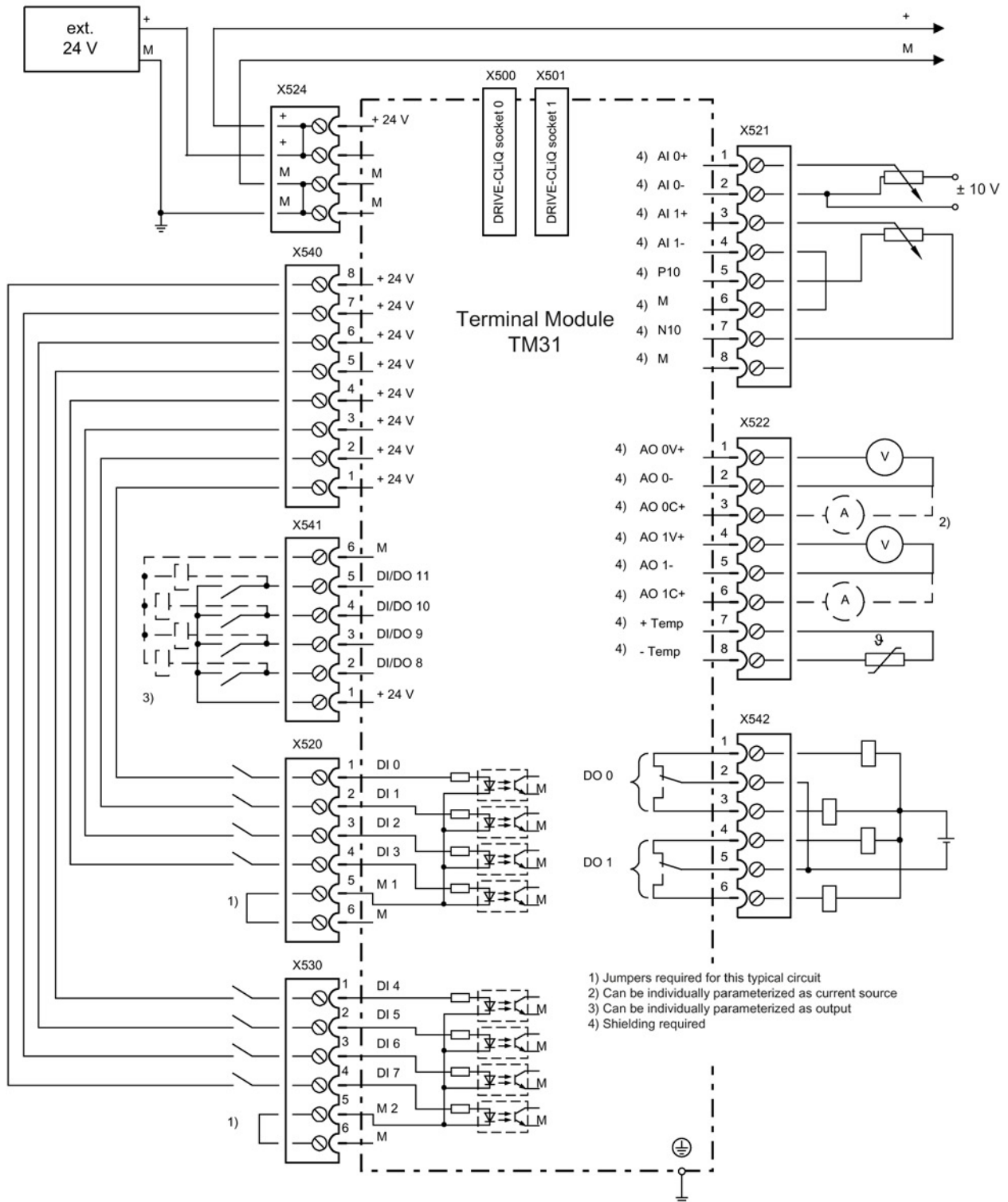

Figure 5-8 Connection example of TM31

### 5.3.4 Meaning of the LED

Table 5- 20 Meanings of the LEDs on the Terminal Module TM31

LED	Color	Status	Description, cause	Remedy
READY	-	Off	The electronics power supply is missing or outside the permissible tolerance range.	-
	Green	Continuous light	The component is ready for operation. Cyclic DRIVE-CLiQ communication is taking place.	-
	Orange	Continuous light	DRIVE-CLiQ communication is being established.	-
	Red	Continuous light	This component has at least one fault. <b>Note:</b> The LED is activated regardless of whether the corresponding messages have been reconfigured.	Remove and acknowledge the fault.
	Green/red	Flashing light 0.5 Hz	Firmware is being downloaded.	-
		Flashing light 2 Hz	Firmware download is complete. The system waits for POWER ON.	Carry out a POWER ON.
	Green/orange or Red/orange	Flashing light	Component recognition via LED is activated <sup>1)</sup> . <b>Note:</b> Both options depend on the LED status when component recognition is activated.	-

<sup>1)</sup> The parameters for activating component recognition using LEDs can be taken from the following reference:  
Reference: /LH1/ SINAMICS S120/S150 List Manual

#### Cause and rectification of faults

Additional information about the cause and resolving faults can be taken from the following references:

- Reference:/LH1/SINAMICS S120/S150 List Manual
- Reference: /IH1/ SINAMICS S120 Commissioning Manual

### 5.3.5 Dimension drawing

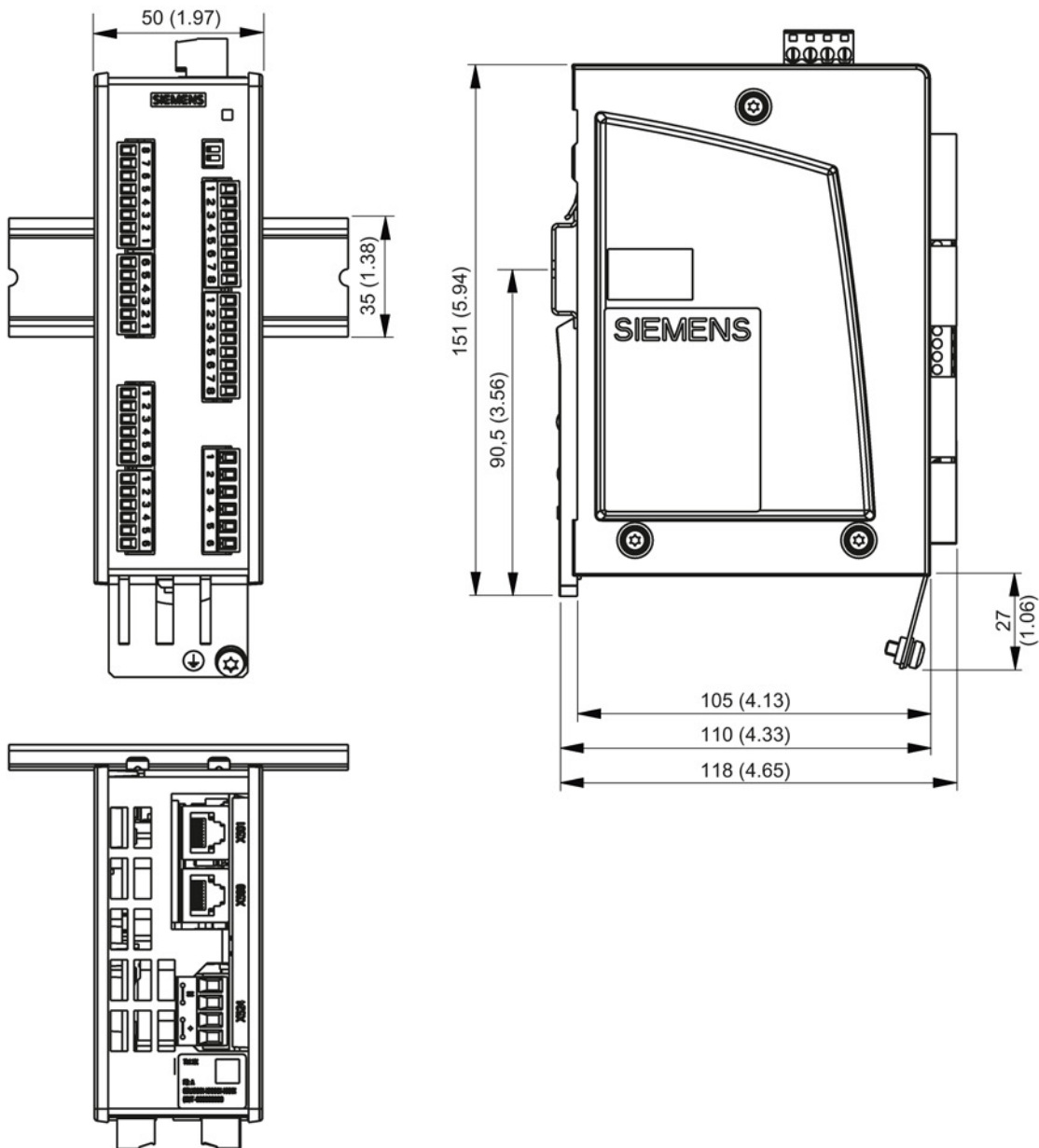

Figure 5-9 Dimension drawing of Terminal Module TM31, all data in mm and (inches)

### 5.3.6 Installation

#### Installation

1. Tilt the component backwards slightly and attach it to the DIN rail using the hooks.
2. Swivel the component onto the DIN rail until you hear the mounting slide at the rear latch into position.
3. Slide the components along the mounting rail to either the left or right up to their final position.

#### Removal

1. First shift the mounting slide downwards at the lug to release the interlocking with the mounting rail.
2. Swivel the component to the front and withdraw it upwards from the DIN rail.

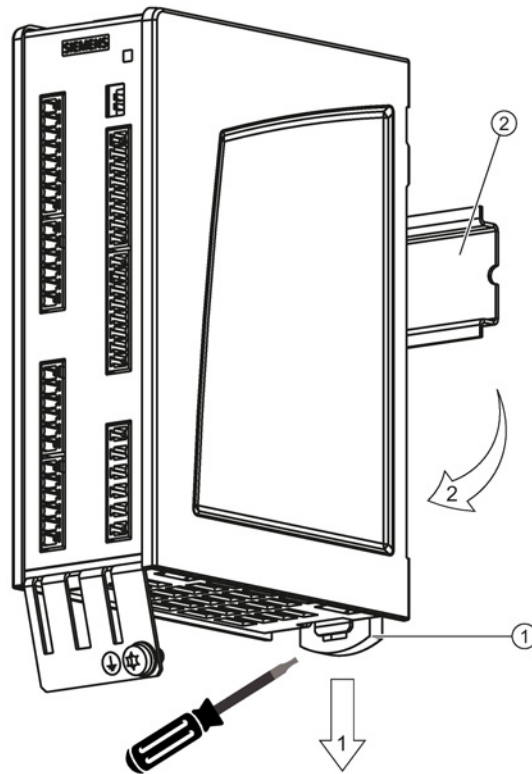

- ① Mounting slide
- ② Mounting rail

Figure 5-10 Removing from a DIN mounting rail

### 5.3.7 Protective conductor connection and shield support

It is always advisable to shield the digital input/output wiring.

The following diagram shows a typical Weidmüller shield connection clamp for the shield supports.

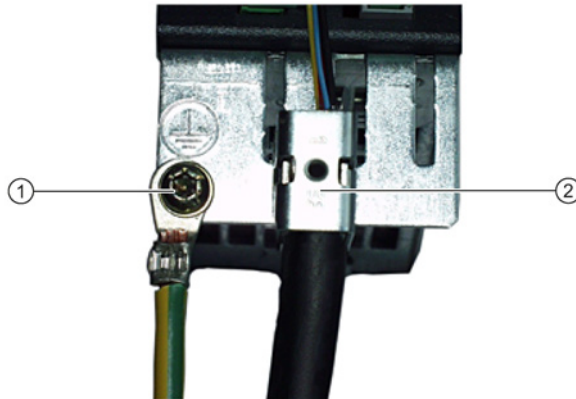

- ① Protective conductor connection M4 / 1.8 Nm
- ② Shield connection terminal, Weidmüller, type: KLBÜ CO1, Article No.: 1753311001

Figure 5-11 Shield support and protective conductor connection

#### NOTICE

##### Damage or faulty operation due to incorrect shielding or inadmissible cable lengths

If the correct shielding procedures or the permissible cable lengths are not observed, it can cause damage or the machine may malfunction.

- Only use shielded cables.
- Do not exceed the cable lengths stated in the technical data.

### 5.3.8 Connector coding

To ensure that identical connectors are assigned correctly on the TM31, the connectors are encoded as shown in the following diagram.

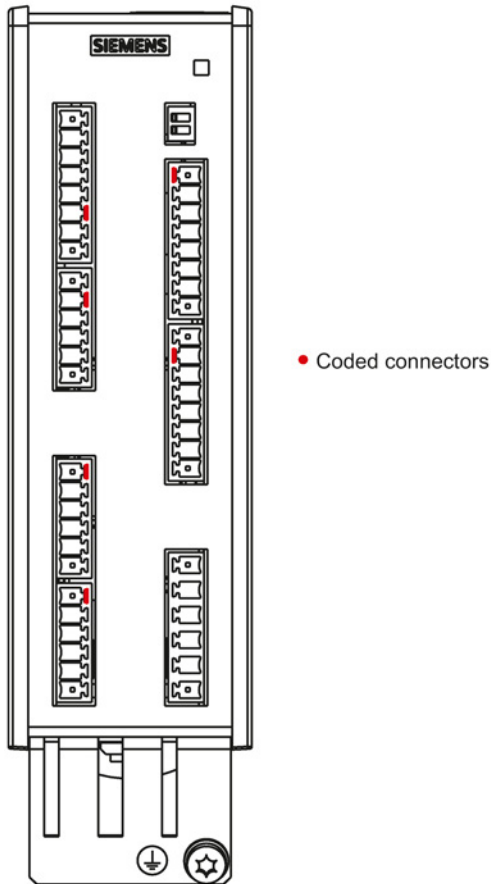

Figure 5-12 Example of connector coding at the TM31

The bending radii of the cables must be taken into account (see description of MOTION-CONNECT).

## 5.3.9 Technical data

Table 5- 21 Technical data

6SL3055-0AA00-3AA1	Unit	Value
<b>Electronics power supply</b>		
Voltage	V <sub>DC</sub>	24 (20.4 ... 28.8)
Current (without DRIVE-CLiQ and digital outputs)	A <sub>DC</sub>	0.5
Power loss	W	< 10
Response time	<p>The response time of the digital inputs/outputs and the analog inputs/outputs comprise the following:</p> <ul style="list-style-type: none"> <li>• Response time on the component itself (approx. 1/2 DRIVE-CLiQ cycle).</li> <li>• Transfer time via the DRIVE-CLiQ connection (approx. 1 DRIVE-CLiQ cycle).</li> <li>• Evaluation on the Control Unit (see function diagram).</li> </ul> <p>Additional information can be taken from the following references: Reference: /LH1/ SINAMICS S120/S150 List Manual, Chapter "Function diagrams/Terminal Module 31"</p>	
PE/ground connection	At the housing with M4/1.8 Nm screw	
Maximum cable lengths:		
electronics power supply	m	30
DRIVE-CLiQ cables	m	100
inputs/outputs	m	30
Weight	kg	0.49
Degree of protection	IP20	

## 5.4 Terminal Module TM41

### 5.4.1 Description

The Terminal Module TM41 is an expansion module that is snapped onto an EN 60715 standard mounting rail.

The encoder interface of the TM41 can be used to emulate an incremental encoder. The TM41 can also be used to connect analog controls to SINAMICS.

The TM41 contains the following interfaces:

Table 5- 22 Interface overview of the TM41

Type	Quantity
DRIVE-CLiQ interfaces	2
Digital inputs, floating	4
Bidirectional digital inputs/outputs	4
Analog inputs	1
TTL encoder output	1



## 5.4.2 Interface description

### 5.4.2.1 Overview

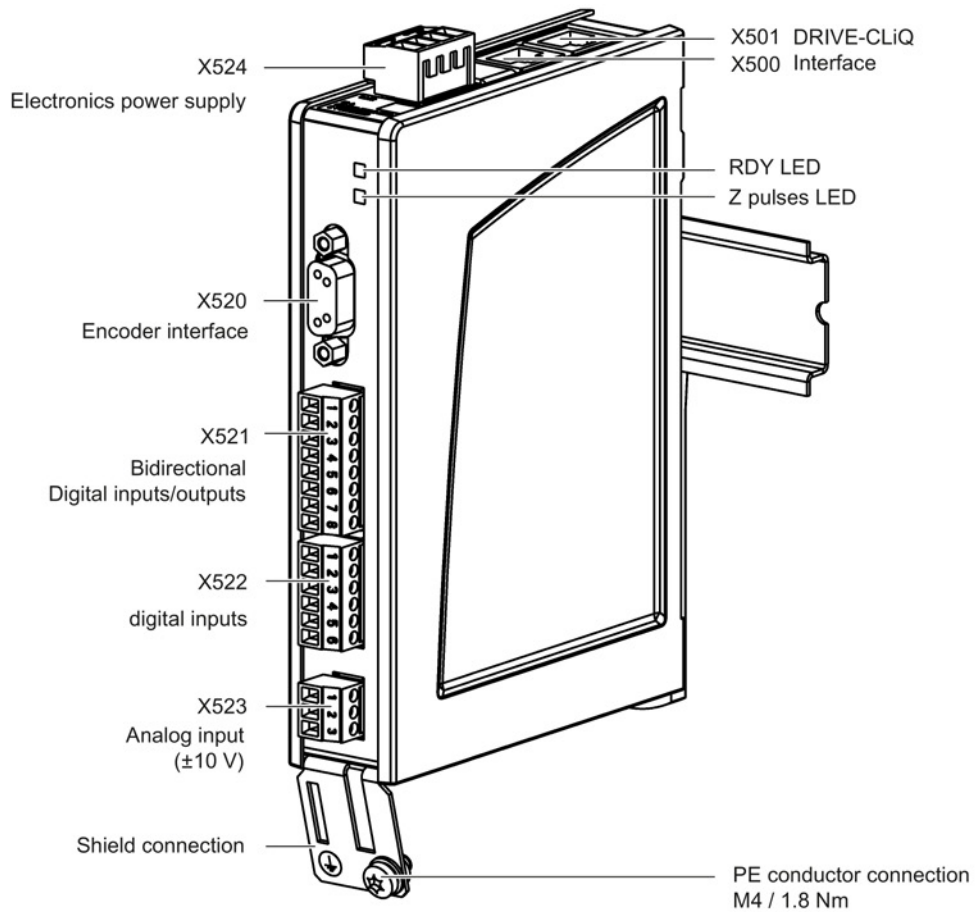
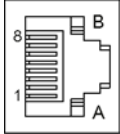

Figure 5-13 TM41 interface overview

## 5.4.2.2 X500/X501 DRIVE-CLiQ interfaces

Table 5- 23 X500/X501: DRIVE-CLiQ interfaces

	Pin	Signal name	Technical data
	1	TXP	Transmit data +
	2	TXN	Transmit data -
	3	RXP	Receive data +
	4	Reserved, do not use	
	5	Reserved, do not use	
	6	RXN	Receive data -
	7	Reserved, do not use	
	8	Reserved, do not use	
	A	+ (24 V)	Power supply
	B	M (0 V)	Electronics ground

The blanking covers for the DRIVE-CLiQ interfaces are included in the scope of delivery.

Blanking covers (50 x) Article No.: 6SL3066-4CA00-0AA0

**Note**

The maximum DRIVE-CLiQ cable length is 100 m.

## 5.4.2.3 X524 electronics power supply

Interface X524 assumes the electronics power supply.

Table 5- 24 X524: Power supply

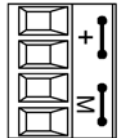
	Terminal	Designation	Technical data
	+	Power supply	Voltage: 24 V DC (20.4 ... 28.8 V) Current consumption: max. 3.1 A <sup>1)</sup>
	+	Power supply	
	M	Electronics ground	Max. current through the jumper in the connector: 20 A (15 A according to UL/CSA)
	M	Electronics ground	
Type: Screw terminal 2 (Page 336)			

<sup>1)</sup> Including the current consumption for the digital outputs and for supplying the sensor

The maximum cable length that can be connected is 30 m.

**Note**

The two "+" or "M" terminals are jumpered in the connector. This ensures that the supply voltage is looped through.

The current consumption of X524 increases by the value for the DRIVE-CLiQ nodes and the digital outputs.

**5.4.2.4 X520 encoder interface**

Table 5- 25 X520: Encoder interface

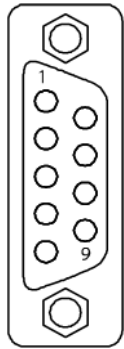
	Pin	Signal name	Technical data
	1	A	Incremental signal A
	2	R	Reference signal R
	3	B	Incremental signal B
	4	Reserved, do not use	
	5	Reserved, do not use	
	6	A*	Inverse incremental signal A
	7	R*	Inverse reference signal R
	8	B*	Inverse incremental signal B
	9	M	Ground
Connector type:	9-pin SUB-D socket; TTL encoder (RS422)		
Max. cable length: 30 m			

**Note**

The X520 encoder interface produces signals acc. to RS422 standard.

## 5.4.2.5 X521 bidirectional digital inputs/outputs

Table 5- 26 X521: Digital inputs/outputs

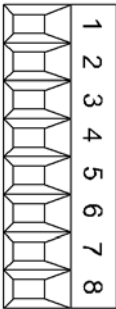
	Terminal	Designation <sup>1)</sup>	Technical data
	1	DI/DO 0	<b>As input:</b> Voltage: -3 ... 30 V DC Current consumption, typical: 10 mA at 24 V Signal level (incl. ripple) High level: 15 ... 30 V Low level: -3 ... +5 V Input delay: for "0" → "1": typ. 50 µs max. 100 µs for "1" → "0": typ. 50 µs, max. 100 µs
	2	DI/DO 1	
	3	DI/DO 2	
	4	DI/DO 3	
	5	+24 V	<b>As output:</b> Voltage: 24 V DC Max. load current per output: 0.5 mA Max. total current of outputs: 2 A Continuously short-circuit proof Output delay: for "0" → "1": typ. 150 µs at 0.5 A resistive load (500 µs maximum) for "1" → "0": Typically 150 µs at 0.5 A resistive load Switching frequency: for ohmic load: Max. 100 Hz For inductive load: Max. 0.5 Hz For lamp load: Max. 10 Hz Maximum lamp load: 5 W
	6	+24 V	
	7	+24 V	
	8	+24 V	
Type: Screw terminal 1 (Page 336) Max. cross-section that can be connected: 1.5 mm <sup>2</sup>			Voltage: 24 V DC Max. total load current of +24 V auxiliary voltage of terminals 5 up to 8 combined: 500 mA

<sup>1)</sup> DI/DO: bidirectional digital input/output

**Note**

This power supply is only for supplying the digital inputs.

**Note**

An open input is interpreted as "low".

**Note**

If the 24 V supply is briefly interrupted, then the digital outputs are deactivated during this time.

### 5.4.2.6 X522 isolated digital inputs

Table 5- 27 X522: Digital inputs

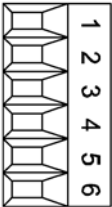
	Terminal	Designation <sup>1)</sup>	Technical data
	1	DI 0	<b>Voltage:</b> -3 ... +30 V DC <b>Current consumption, typical:</b> 6.5 mA at 24 V <b>Electrical isolation:</b> Reference potential is terminal M1 <b>Signal level (including ripple)</b> High level: 15 ... 30 V Low level: -3 ... +5 V <b>Input delay:</b> For "0" → "1": typ. 50 µs max. 100 µs For "1" → "0": typ. 110 µs, max. 150 µs
	2	DI 1	
	3	DI 2	
	4	DI 3	
	5	M1	
	6	M	
Type: Screw terminal 1 (Page 336) Max. cross-section that can be connected: 1.5 mm <sup>2</sup>			

<sup>1)</sup> DI: Digital input; M: Electronics ground; M1: Ground reference

#### Note

#### Ensuring the function of digital inputs

Terminal M1 must be connected so that the digital inputs (DI) can function.

This is achieved by using one of the following measures:

1. Providing the ground reference of the digital inputs
2. A jumper to terminal M

**Note:** This removes isolation for these digital inputs.

## 5.4.2.7 X523 analog input

Table 5- 28 X523: Analog input

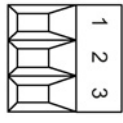
	Terminal	Designation <sup>1)</sup>	Technical data
	1	AI 0-	<b>Voltage:</b> -10 ... +10 V; $R_i > 100 \text{ k}\Omega$ <b>Resolution:</b> 12 bits + sign
	2	AI 0+	
	3	Reserved, do not use	
Type: Screw terminal 1 (Page 336) Max. cross-section that can be connected: 1.5 mm <sup>2</sup>			

<sup>1)</sup> AI: analog input

**Note****Permissible voltage values**

The common mode range must not be violated in order to avoid incorrect analog-digital conversion results. The following voltages are permissible:

- Input voltage:  $\pm 30 \text{ V}$  (destruction limit)
- Common mode voltage:  $\pm 10 \text{ V}$  (increased errors when exceeded)

### 5.4.3 Connection example

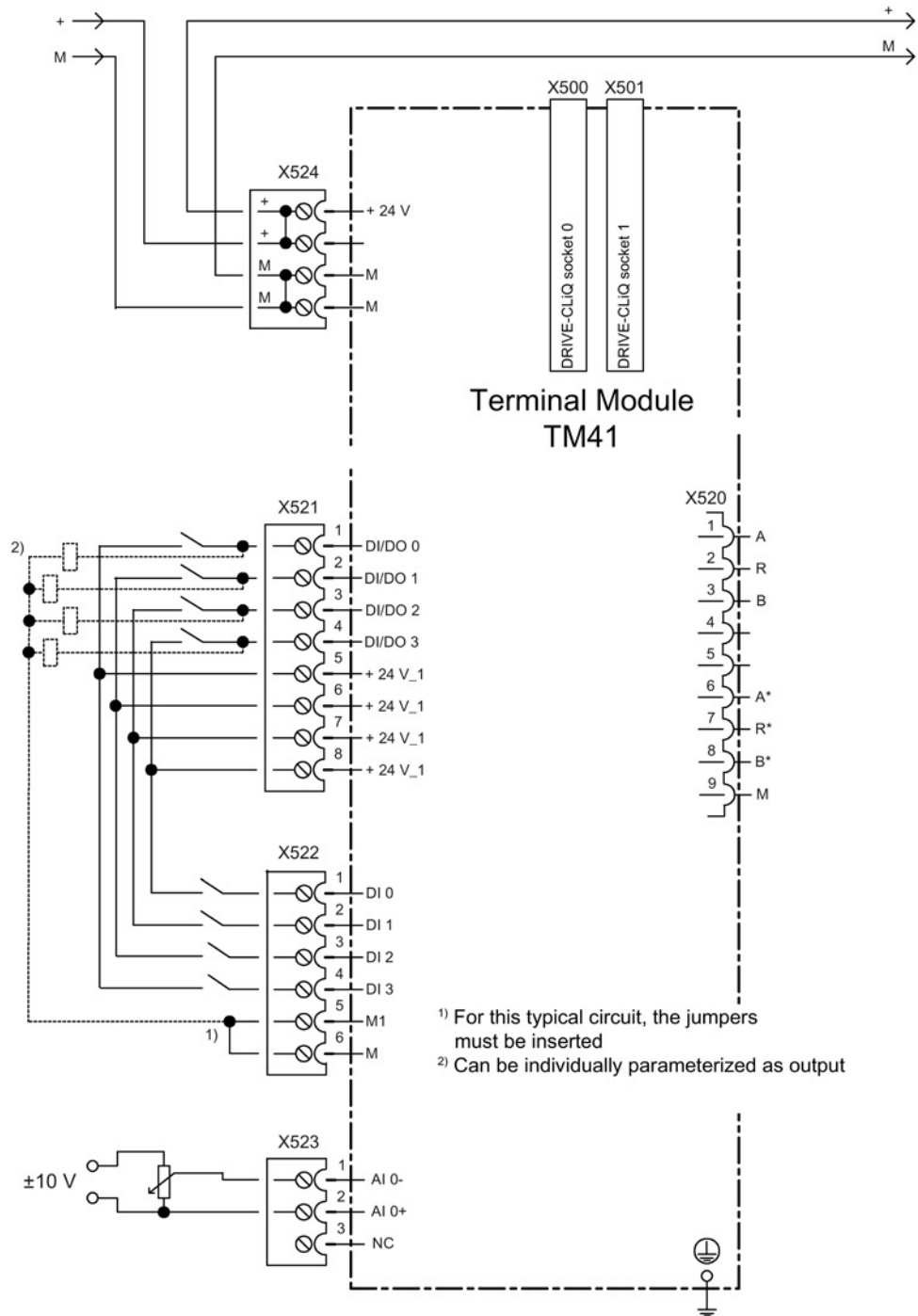

Figure 5-14 Sample connection of TM41

### 5.4.4 Meaning of the LEDs

Table 5- 29 Meaning of the LEDs on the Terminal Module TM41

LED	Color	Status	Description, cause	Remedy	
READY	-	Off	The electronics power supply is missing or outside the permissible tolerance range.	-	
	Green	Continuous light	The component is ready for operation. Cyclic DRIVE-CLiQ communication is taking place.	-	
	Orange	Continuous light	DRIVE-CLiQ communication is being established.	-	
	Red	Continuous light	This component has at least one fault. <b>Note:</b> The LED is activated regardless of whether the corresponding messages have been reconfigured.	Remove and acknowledge the fault.	
	Green/red	Flashing light 0.5 Hz	Flashing light 0.5 Hz	Firmware is being downloaded.	-
			Flashing light 2 Hz	Firmware download is complete. The system waits for POWER ON.	Carry out a POWER ON.
	Green/orange or Red/orange	Flashing light	Component recognition via LED is activated <sup>1)</sup> . <b>Note:</b> Both options depend on the LED status when component recognition is activated.	-	
Z pulses	-	Off	The zero mark was found and the system waits for the zero mark output. OR The component is switched off.	-	
	Red	Continuous light	The zero mark has not been released, or the zero mark search is running.	-	
	Green	Continuous light	The system stops at the zero mark.	-	
		Flashing light	The zero mark is output at each virtual revolution.	-	

<sup>1)</sup> The parameters for activating component recognition using LEDs can be taken from the following reference:  
Reference: /LH1/ SINAMICS S120/S150 List Manual

#### Cause and rectification of faults

Additional information about the cause and resolving faults can be taken from the following references:

- Reference:/LH1/SINAMICS S120/S150 List Manual
- Reference: /IH1/ SINAMICS S120 Commissioning Manual



5.4.5 Dimension drawing

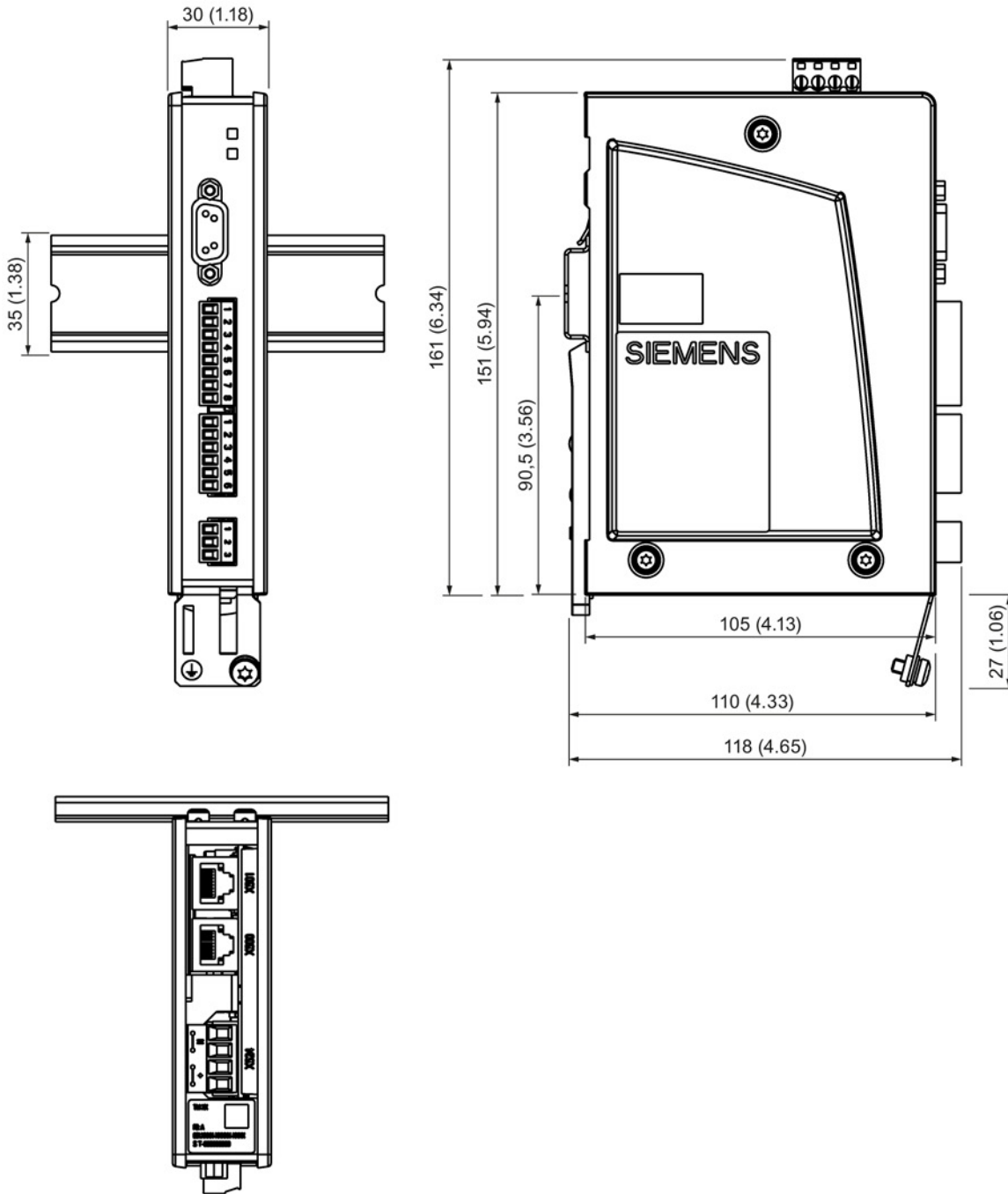

Figure 5-15 Dimension drawing of Terminal Module TM41, all data in mm and (inches)

## 5.4.6 Installation

### Installation

1. Tilt the component backwards slightly and attach it to the DIN rail using the hooks.
2. Swivel the component onto the DIN rail until you hear the mounting slide at the rear latch into position.
3. Slide the components along the mounting rail to either the left or right up to their final position.

### Removal

1. First shift the mounting slide downwards at the lug to release the interlocking with the mounting rail.
2. Swivel the component to the front and withdraw it upwards from the DIN rail.

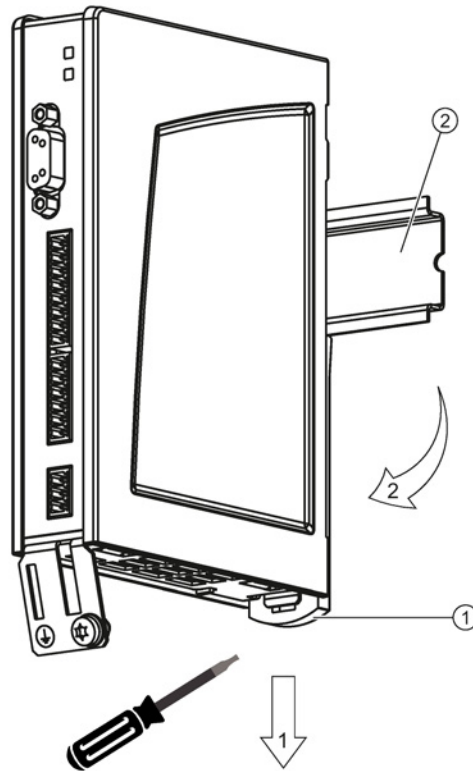

- ① Mounting slide
- ② Mounting rail

Figure 5-16 Removing from a DIN mounting rail

### 5.4.7 Protective conductor connection and shield support

It is always advisable to shield the digital input/output wiring.

The following diagram shows a typical Weidmüller shield connection clamp for the shield supports.

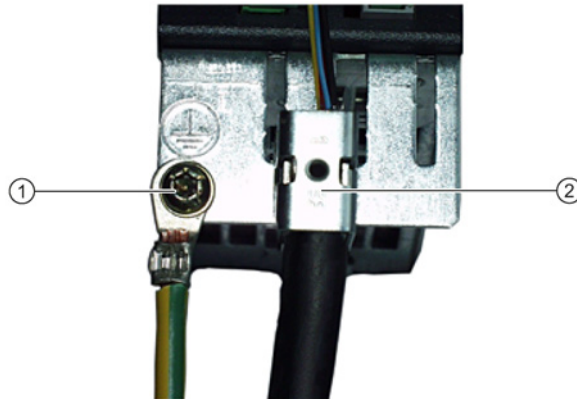

- ① Protective conductor connection M4 / 1.8 Nm
- ② Shield connection terminal, Weidmüller, type: KLBÜ CO1, Article No.: 1753311001

Figure 5-17 Shield support and protective conductor connection

The bending radii of the cables must be taken into account (see description of MOTION-CONNECT).

#### NOTICE

##### Damage or faulty operation due to incorrect shielding or inadmissible cable lengths

If the correct shielding procedures or the permissible cable lengths are not observed, it can cause damage or the machine may malfunction.

- Only use shielded cables.
- Do not exceed the cable lengths stated in the technical data.

## 5.4.8 Technical data

Table 5- 30 Technical data

6SL3055-0AA00-3PA1	Unit	Value
<b>Electronics power supply</b>		
Voltage	V <sub>DC</sub>	24 (20.4 ... 28.8)
Current (without DRIVE-CLiQ and digital outputs)	A <sub>DC</sub>	0.5
Power loss	W	12
Response time	<p>The response time of the digital inputs/outputs and the analog input comprise the following:</p> <ul style="list-style-type: none"> <li>• Response time on the component itself (approx. 1/2 DRIVE-CLiQ cycle).</li> <li>• Transfer time via the DRIVE-CLiQ connection (approx. 1 DRIVE-CLiQ cycle).</li> <li>• Evaluation on the Control Unit (see function diagram).</li> </ul> <p>Additional information can be taken from the following references: Reference: /LH1/ SINAMICS S120/S150 List Manual, Chapter "Function diagrams/Terminal Module 41"</p>	
PE/ground connection	At the housing with M4/1.8 Nm screw	
Maximum cable lengths:		
electronics power supply	m	30
DRIVE-CLiQ cables	m	100
inputs/outputs	m	30
Weight	kg	0.32
Degree of protection	IP20	

## 5.5 Terminal Module TM54F

### 5.5.1 Description

The Terminal Module TM54F is a terminal expansion for snapping on to an EN 60715 standard mounting rail. The TM54F has fail-safe digital inputs and digital outputs for controlling SINAMICS Safety Integrated functions.

The TM54F connection should be established via the DRIVE-CLiQ directly at a Control Unit. Only one TM54F can be assigned to each Control Unit.

Additional DRIVE-CLiQ nodes can be operated at the TM54F, such as Sensor Modules and Terminal Modules (excluding an additional TM54F). Motor Modules and Line Modules should not be connected to a TM54F.

TM54F features the following interfaces:

Table 5- 31 Interface overview of the TM54F

Type	Quantity
DRIVE-CLiQ interfaces	2
Fail-safe digital outputs (F-DO)	4
Fail-safe digital inputs (F-DI)	10
Sensor <sup>1)</sup> power supplies, dynamization supported <sup>2)</sup>	2
Sensor <sup>1)</sup> power supply, no dynamization	1
Digital inputs to check F_DO for a test stop	4

<sup>1)</sup> Sensors: Fail-safe devices to issue commands and sense, for example, Emergency Stop pushbuttons and safety locks, position switches and light arrays/light curtains.

<sup>2)</sup> Dynamic response: The sensor power supply is cycled on and off by the TM54F when the forced checking procedure is active for the sensors, cable routing, and the evaluation electronics.

The TM54F has 4 fail-safe digital outputs and 10 fail-safe digital inputs. A fail-safe digital output consists of a 24 V DC switching output, a ground switching output, and a digital input for checking the switching state. A fail-safe digital input is made up of 2 digital inputs.

---

#### Note

The rated values of the F-DO meet the requirements of EN 61131-2 for digital DC outputs with 0.5 A rated current.

The operating ranges of the F-DI meet the requirements of EN 61131-2 for Type 1 digital inputs.

---

#### Note

For cable lengths > 30 m, shielded cables must be used for the F-DI.

---

## 5.5.2 Interface description

### 5.5.2.1 Overview

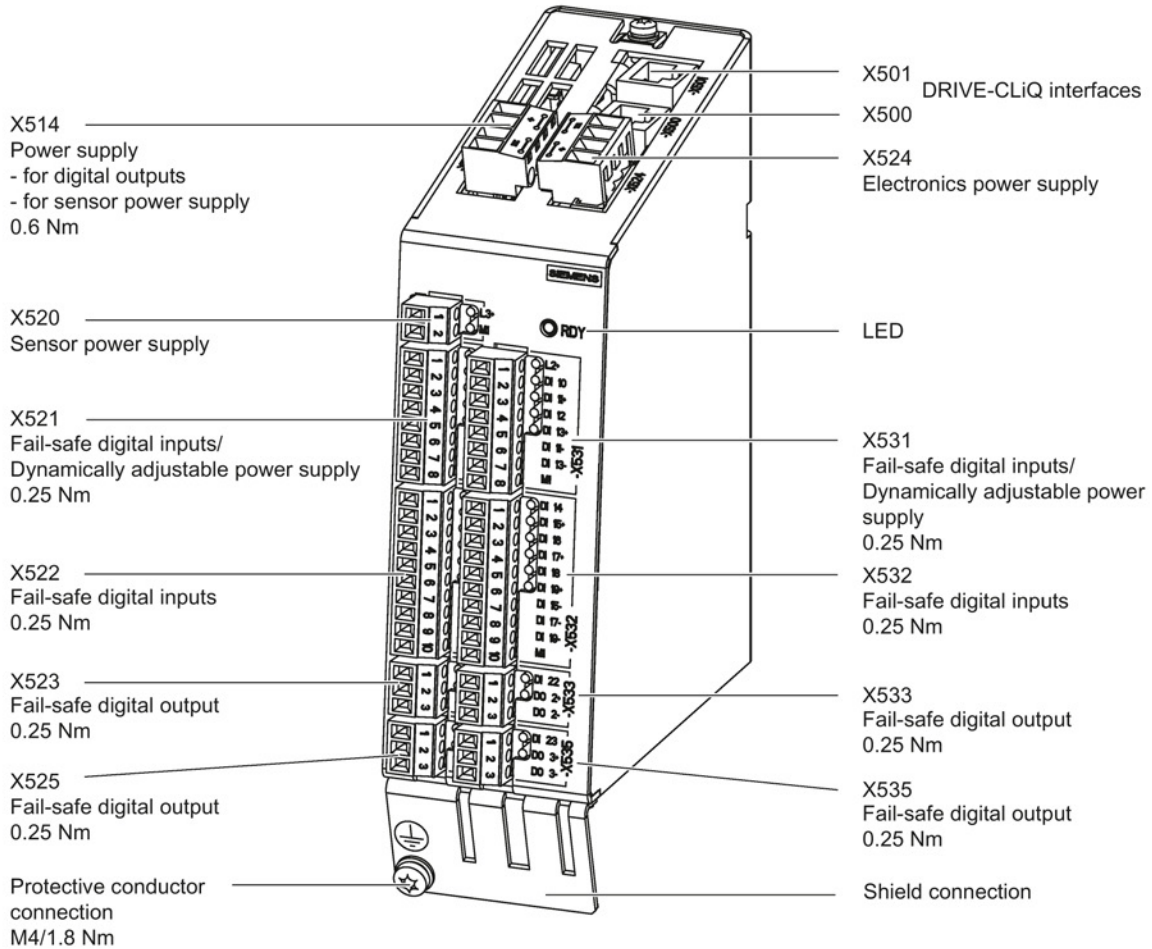
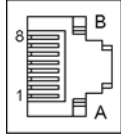

Figure 5-18 TM54 interface overview

### 5.5.2.2 X500/X501 DRIVE-CLiQ interfaces

Table 5- 32 X500/X501: DRIVE-CLiQ interfaces

	Pin	Signal name	Technical data
	1	TXP	Transmit data +
	2	TXN	Transmit data -
	3	RXP	Receive data +
	4	Reserved, do not use	
	5	Reserved, do not use	
	6	RXN	Receive data -
	7	Reserved, do not use	
	8	Reserved, do not use	
	A	+ (24 V)	Power supply
	B	M (0 V)	Electronics ground

The blanking covers for the DRIVE-CLiQ interfaces are included in the scope of delivery.

Blanking covers (50 x) Article No.: 6SL3066-4CA00-0AA0

#### Note

The maximum DRIVE-CLiQ cable length is 100 m.

### 5.5.2.3 X514 power supply for digital outputs and sensors

Table 5- 33 X514: Power supply

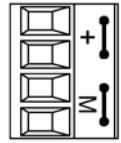
	Terminal	Designation	Technical data
	+	Power supply	Voltage: 24 V DC (20.4 ... 28.8 V) Current consumption: max. 4.0 A <sup>1)</sup> Max. current through the jumper in the connector: 20 A (15 A according to UL/CSA)
	+	Power supply	
	M1	Electronics ground	
	M1	Electronics ground	

Type: Screw terminal 2 (Page 336)  
Max. cross-section that can be connected: 2.5 mm<sup>2</sup>

<sup>1)</sup> Including the current consumption for the digital outputs and to supply the sensor.

The maximum cable length that can be connected is 30 m.

#### Note

The two "+" or "M1" terminals are jumpered in the connector. This ensures that the supply voltage is looped through.

## 5.5.2.4 X520 sensor power supply

Table 5- 34 X520: Sensor power supply

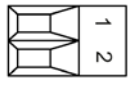
	Terminal	Designation	Technical data
	1	L3	Voltage: +24 V DC Max. total load current: 500 mA
	2	M1	

Without forced dormant error detection

## 5.5.2.5 X521 fail-safe digital inputs + power supply with forced dormant error detection

Table 5- 35 X521: Fail-safe digital inputs

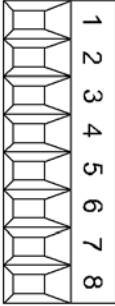
	Terminal	Designation <sup>1)</sup>	Technical data	
	1	L1+	Switched voltage: +24 V DC Max. total load current: 500 mA (voltage is switched for a test stop)	
	2	DI 0	F-DI 0	
	3	DI 1+		
	4	DI 2	F-DI 1	
	5	DI 3+		
	6	DI 1-	F-DI 0	Reference potential for DI 1+
	7	DI 3-	F-DI 1	Reference potential for DI 3+
	8	M1		Reference potential for DI 0, DI 2, L1+
An F-DI consists of a digital input and a 2nd digital input where, in addition, the cathode of the optocoupler is fed-out. F-DI 0 = terminals 2, 3 and 6 F-DI 1 = terminals 4, 5 and 7				
Type: Screw terminal 1 (Page 336) Max. cross-section that can be connected: 1.5 mm <sup>2</sup>				

1) DI: Digital input, F-DI: Fail-safe digital input

2) Pure hardware delay



---

**Note**

**Execution of a test stop**

The test stop of the F-DI 0 to F-DI 4 can only be performed if the F-DI is supplied from L1+.

---

**Note**

**Ensuring the function of digital inputs**

For the digital inputs DIx+ to function, the reference potential must be connected to input DIx- in each case.

This is achieved by using one of the following measures:

1. Providing the ground reference of the digital inputs
  2. A jumper between DIx- and terminal M1
-

## 5.5.2.6 X522 fail-safe digital inputs

Table 5- 36 X522: Fail-safe digital inputs

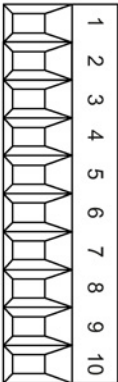
	Terminal	Designation <sup>1)</sup>		Technical data
	1	DI 4	F-DI 2	<b>Voltage:</b> -3 ... +30 V DC <b>Current consumption</b> typical: 3.2 mA at 24 V <b>Electrical isolation:</b> Reference potential, see terminals 7, 8, 9, 10 All digital inputs are isolated. <b>Signal level</b> (including ripple) High level: 15 ... 30 V Low level: -3 ... +5 V <b>Input delay:</b> <sup>2)</sup> for "0" → "1": 30 μs (100 Hz) for "1" → "0": 60 μs (100 Hz)
	2	DI 5+		
	3	DI 6	F-DI 3	
	4	DI 7+		
	5	DI 8	F-DI 4	
	6	DI 9+		
	7	DI 5-		
	8	DI 7-	Reference potential for DI 7+	
	9	DI 9-	Reference potential for DI 9+	
	10	M1	Reference potential for DI 4, DI 6 and DI 8	
An F-DI consists of a digital input and a 2nd digital input where, in addition, the cathode of the optocoupler is fed-out. F-DI 2 = terminals 1, 2 and 7 F-DI 3 = terminals 3, 4 and 8 F-DI 4 = terminals 5, 6 and 9				
Type: Screw terminal 1 (Page 336) Max. cross-section that can be connected: 1.5 mm <sup>2</sup>				

1) DI: Digital input, F-DI: Fail-safe digital input

2) Pure hardware delay

**Note****Execution of a test stop**

The test stop of the F-DI 0 to F-DI 4 can only be performed if the F-DI is supplied from L1+.

**Note****Ensuring the function of digital inputs**

For the digital inputs DIx+ to function, the reference potential must be connected to input DIx- in each case.

This is achieved by using one of the following measures:

1. Providing the ground reference of the digital inputs
2. A jumper between DIx- and terminal M1

### 5.5.2.7 X523 fail-safe digital output

Table 5- 37 X523: Fail-safe digital output

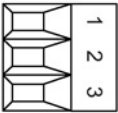
	Terminal	Designation <sup>1)</sup>	Technical data	
	1	DI 20	<b>Voltage:</b> -3 ... +30 V DC <b>Current consumption</b> typical: 3.2 mA at 24 V <b>Electrical isolation:</b> Reference potential is terminal M1. The digital input is electrically isolated. <b>Signal level</b> (including ripple) High level: 15 ... 30 V Low level: -3 ... +5 V <b>Input delay:</b> <sup>2)</sup> for "0" → "1": 30 μs (100 Hz) for "1" → "0": 60 μs (100 Hz)	
	2	DO 0+		F-DO 0 0.5 A (reference potential is terminal M1) 0.5 A (reference potential is terminal L1+, L2+ or L3+) <b>Output delay:</b> <sup>2)</sup> for "0" → "1": 300 μs for "1" → "0": 350 μs <b>Current consumption</b> In total all DOs: 2 A Max. leakage current: < 0.5 mA <b>Switching frequency:</b> for ohmic load: Max. 100 Hz For inductive load: Max. 0.5 Hz For lamp load: Max. 10 Hz Maximum lamp load: 5 W
	3	DO 0-		
An F-DO comprises two digital outputs and one digital input for feedback F-DO 0 = terminals 1, 2, and 3 Type: Screw terminal 1 (Page 336) Max. cross-section that can be connected: 1.5 mm <sup>2</sup>				

1) DI: Digital input; DO: digital output F-DO: Fail-safe digital output

2) Pure hardware delay

### 5.5.2.8 X524 electronics power supply

Table 5- 38 X524: Electronics power supply

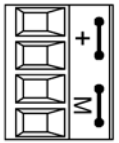
	Terminal	Designation	Technical data
	+	Electronics power supply	<b>Voltage:</b> 24 V DC (20.4 ... 28.8 V) <b>Current consumption:</b> max. 0.7 A Max. current through the jumper in the connector: 20 A (15 A according to UL/CSA)
	+	Electronics power supply	
	M	Electronics ground	
	M	Electronics ground	
Type: Screw terminal 2 (Page 336)			

The maximum cable length that can be connected is 30 m.

**Note**

The two "+" or "M" terminals are jumpered in the connector. This ensures that the supply voltage is looped through.

The current consumption increases by the value for the DRIVE-CLiQ node.

**5.5.2.9 X525 fail-safe digital output**

Table 5- 39 X525: Fail-safe digital output

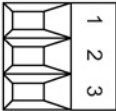
	Terminal	Designation <sup>1)</sup>	Technical data	
	1	DI 21	<b>Voltage:</b> -3 ... +30 V DC <b>Current consumption</b> typical: 3.2 mA at 24 V <b>Electrical isolation:</b> Reference potential is terminal M1. The digital input is electrically isolated. <b>Signal level</b> (including ripple) High level: 15 ... 30 V Low level: -3 ... +5 V <b>Input delay:</b> <sup>2)</sup> for "0" → "1": 30 μs (100 Hz) for "1" → "0": 60 μs (100 Hz)	
	2	DO 1+		0.5 A (reference potential is terminal M1) 0.5 A (reference potential is terminal L1+, L2+ or L3+) <b>Output delay:</b> <sup>2)</sup> for "0" → "1": 300 μs for "1" → "0": 350 μs <b>Current consumption</b> In total all DOs: 2 A Max. leakage current: < 0.5 mA <b>Switching frequency:</b> for ohmic load: Max. 100 Hz for inductive load: Max. 0.5 Hz for lamp load: Max. 10 Hz Maximum lamp load: 5 W
	3	DO 1-		
An F-DO comprises 2 digital outputs and 1 digital input for feedback signal F-DO 1 = terminals 1, 2, and 3 Type: Screw terminal 1 (Page 336) Max. cross-section that can be connected: 1.5 mm <sup>2</sup>				

<sup>1)</sup> DI: Digital input; DO: Digital output F-DO: Fail-safe digital output

<sup>2)</sup> Pure hardware delay

### 5.5.2.10 X531 fail-safe digital inputs + power supply with forced dormant error detection

Table 5- 40 X531: Fail-safe digital inputs

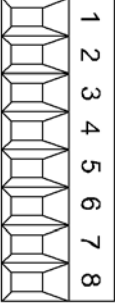
	Terminal	Designation <sup>1)</sup>		Technical data
	1	L2+		Switched voltage: +24 V DC Max. total load current: 500 mA (voltage is switched for a test stop)
	2	DI 10	F-DI 5	<b>Voltage:</b> -3 ... +30 V DC <b>Current consumption</b> typical: 3.2 mA at 24 V <b>Electrical isolation:</b> Reference potential, see terminal 6, 7, 8 All digital inputs are isolated. <b>Signal level</b> (including ripple) High level: 15 ... 30 V Low level: -3 ... +5 V <b>Input delay:</b> <sup>2)</sup> for "0" → "1": 30 μs (100 Hz) for "1" → "0": 60 μs (100 Hz)
	3	DI 11+		
	4	DI 12	F-DI 6	
	5	DI 13+		
	6	DI 11-	F-DI 5	Reference potential to DI 11+
	7	DI 13-	F-DI 6	Reference potential to DI 13+
	8	M1	Reference potential to DI 10, DI 12, L2+	
An F-DI consists of 1 digital input and a 2nd digital input where, in addition, the cathode of the optocoupler is fed-out. F-DI 5 = terminals 2, 3 and 6 F-DI 6 = terminals 4, 5 and 7				
Type: Screw terminal 1 (Page 336) Max. cross-section that can be connected: 1.5 mm <sup>2</sup>				

1) DI: Digital input, F-DI: Fail-safe digital input

2) Pure hardware delay

#### Note

##### Execution of a test stop

The test stop of the F-DI 5 to F-DI 9 can only be performed if the F-DI is supplied from L2+.

#### Note

##### Ensuring the function of digital inputs

For the digital inputs DIx+ to function, the reference potential must be connected to input DIx- in each case.

This is achieved by using one of the following measures:

1. Providing the ground reference of the digital inputs
2. A jumper between DIx- and terminal M1

## 5.5.2.11 X532 fail-safe digital inputs

Table 5- 41 X532: Fail-safe digital inputs

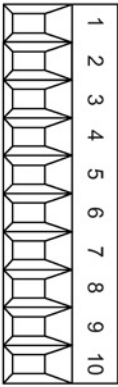
	Terminal	Designation <sup>1)</sup>	Technical data	
	1	DI 14	F-DI 7	
	2	DI 15+		
	3	DI 16	F-DI 8	
	4	DI 17+		
	5	DI 18	F-DI 9	
	6	DI 19+		
	7	DI 15-	F-DI 7	Reference potential for DI 15+
	8	DI 17-	F-DI 8	Reference potential for DI 17+
	9	DI 19-	F-DI 9	Reference potential for DI 19+
	10	M1		Reference potential for DI 14, DI 16 and DI 18
<p>An F-DI consists of 1 digital input and a 2nd digital input where, in addition, the cathode of the optocoupler is fed-out.            F-DI 7 = terminals 1, 2 and 7            F-DI 8 = terminals 3, 4 and 8            F-DI 9 = terminals 5, 6 and 9</p> <p>Type: Screw terminal 1 (Page 336)            Max. cross-section that can be connected: 1.5 mm<sup>2</sup></p>				

1) DI: Digital input, F-DI: Fail-safe digital input

2) Pure hardware delay

**Note****Execution of a test stop**

The test stop of the F-DI 5 to F-DI 9 can only be performed if the F-DI is supplied from L2+.

**Note****Ensuring the function of digital inputs**

For the digital inputs DIx+ to function, the reference potential must be connected to input DIx- in each case.

This is achieved by using one of the following measures:

1. Providing the ground reference of the digital inputs
2. A jumper between DIx- and terminal M1

### 5.5.2.12 X533 fail-safe digital output

Table 5- 42 X533: Fail-safe digital output

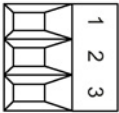
	Terminal	Designation <sup>1)</sup>	Technical data	
	1	DI 22	<b>Voltage:</b> -3 ... +30 V DC <b>Current consumption</b> typical: 3.2 mA at 24 V <b>Electrical isolation:</b> Reference potential is terminal M1. The digital input is electrically isolated. <b>Signal level</b> (including ripple) High level: 15 ... 30 V Low level: -3 ... +5 V <b>Input delay:</b> <sup>2)</sup> for "0" → "1": 30 μs (100 Hz) for "1" → "0": 60 μs (100 Hz)	
	2	DO 2+		0.5 A (reference potential is terminal M1) 0.5 A (reference potential is terminal L1+, L2+ or L3+) <b>Output delay:</b> <sup>2)</sup> for "0" → "1": 300 μs for "1" → "0": 350 μs <b>Current consumption</b> In total all DOs: 2 A Max. leakage current: < 0.5 mA <b>Switching frequency:</b> for ohmic load: Max. 100 Hz For inductive load: Max. 0.5 Hz For lamp load: Max. 10 Hz Maximum lamp load: 5 W
	3	DO 2-		
An F-DO comprises 2 digital outputs and 1 digital input for feedback signal F-DO 2 = terminals 1, 2, and 3 Type: Screw terminal 1 (Page 336) Max. cross-section that can be connected: 1.5 mm <sup>2</sup>				

1) DI: Digital input; DO: Digital output F-DO: Fail-safe digital output

2) Pure hardware delay

## 5.5.2.13 X535 fail-safe digital output

Table 5- 43 X535: Fail-safe digital output

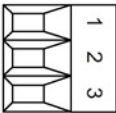
	Terminal	Designation <sup>1)</sup>	Technical data	
	1	DI 23	<b>Voltage:</b> -3 ... +30 V DC <b>Current consumption</b> typical: 3.2 mA at 24 V <b>Electrical isolation:</b> Reference potential is terminal M1. The digital input is electrically isolated. <b>Signal level</b> (including ripple) High level: 15 ... 30 V Low level: -3 ... +5 V <b>Input delay:</b> <sup>2)</sup> for "0" → "1": 30 μs (100 Hz) for "1" → "0": 60 μs (100 Hz)	
	2	DO 3+		F-DO 3 0.5 A (reference potential is terminal M1) 0.5 A (reference potential is terminal L1+, L2+ or L3+) <b>Output delay:</b> <sup>2)</sup> for "0" → "1": 300 μs for "1" → "0": 350 μs <b>Current consumption</b> In total all DOs: 2 A Max. leakage current: < 0.5 mA <b>Switching frequency:</b> for ohmic load: Max. 100 Hz For inductive load: Max. 0.5 Hz For lamp load: Max. 10 Hz Maximum lamp load: 5 W
	3	DO 3-		
An F-DO comprises 2 digital outputs and 1 digital input for feedback signal F-DO 3 = terminals 1, 2, and 3 Type: Screw terminal 1 (see Screw terminals (Page 336)) Max. connectable cross-section: 1.5 mm <sup>2</sup>				

<sup>1)</sup> DI: Digital input; DO: Digital output F-DO: Fail-safe digital output

<sup>2)</sup> Pure hardware delay



### 5.5.3 Connection example

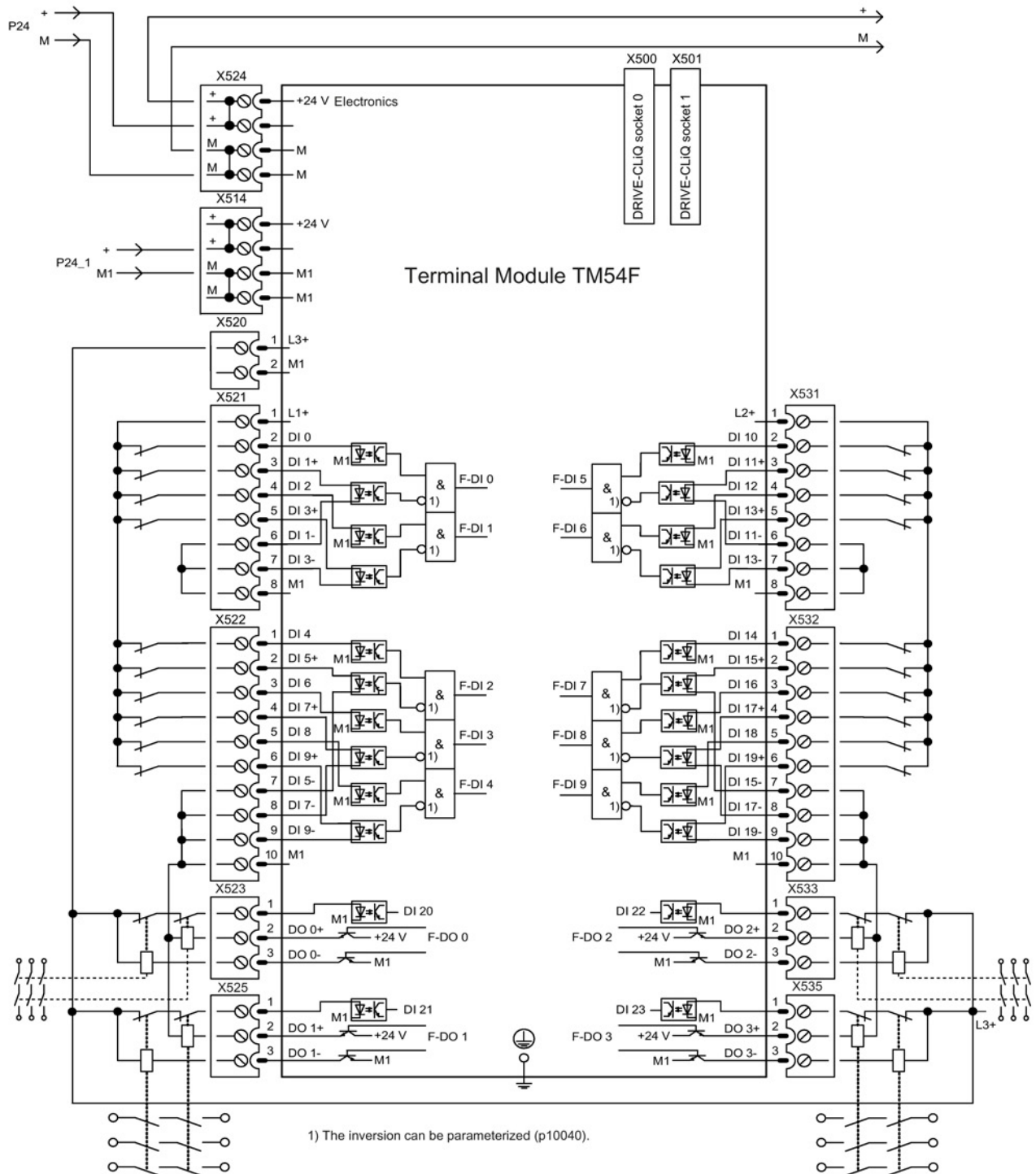

Figure 5-19 Connection example off TM54F

## 5.5.4 Meaning of the LEDs

Table 5- 44 Meaning of the LEDs on the Terminal Module TM54F

LED	Color	Status	Description, cause	Remedy	
READY	-	Off	The electronics power supply is missing or outside the permissible tolerance range.	-	
	Green	Continuous light	The component is ready for operation, cyclic DRIVE-CLiQ communication is taking place.	-	
	Orange	Continuous light	DRIVE-CLiQ communication is being established.	-	
	Red	Continuous light	This component has at least one fault. <b>Note:</b> The LED is activated irrespective of whether the corresponding messages have been reconfigured.	Remedy and acknowledge fault	
	Green/red	Flashing light	0.5 Hz	Firmware is being downloaded.	-
			2 Hz	Firmware download is complete. Wait for POWER ON.	Carry out a POWER ON
	Green / orange or Red / orange	Flashing light	Component recognition via LED is activated. This function can be parameterized Additional information can be taken from the following reference: Reference: /LH1/ SINAMICS S120/S150 List Manual <b>Note:</b> Both options depend on the LED status when component recognition is activated.	-	
L1+, L2+,	-	ON	The controllable sensor power supply is functioning fault-free.	-	
	Red	Continuous light	There is a fault in the controllable sensor power supply.	-	
L3+	-	ON	The sensor power supply is operating fault-free.		
	Red	Continuous light	The sensor power supply has a fault.		

LED	Color		Status	Description, cause	Remedy
<b>Fail-safe inputs / double inputs</b>					
F_DI z (input x, (x+1)+, (x+1)-)	<b>LED</b>	<b>LED</b>			–
	x	x+1		<b>NC contact/NC contact<sup>1)</sup>: (z = 0 ... 9, x = 0, 2, ... 18)</b>	
	–	Red	Continuous light	Different signal states at input x and x+1	
	–	–	–	No signal at input x and no signal at input x+1	
				<b>NC contact/NO contact<sup>1)</sup>: (z = 0 ... 9, x = 0, 2, ... 18)</b>	
	–	Red	Continuous light	Same signal states at input x and x+1	
	–	–	–	No signal at input x and no signal at input x+1	
	<b>LED</b>	<b>LED</b>			
	x	x+1		<b>NC contact/NC contact<sup>1)</sup>: (z = 0 ... 9, x = 0, 2, ... 18)</b>	
	Green	Green	Continuous light	One signal at input x and one signal at input x+1	
			<b>NC contact/NO contact<sup>1)</sup>: (z = 0 ... 9, x = 0, 2, ... 18)</b>		
Green	Green	Continuous light	One signal at input x and no signal at input x+1	–	
<b>Single digital inputs, not fail-safe</b>					
DI x	–		Off	No signal at digital input x (x = 20 ... 23)	–
	Green		Continuous light	Signal at digital input x	–
<b>Fail-safe digital outputs with associated readback channel</b>					
F_DO y (0+...3+, 0-...3-)	Green		Continuous light	Output y (y = 0 ... 3) has an active signal	–
Readback input DI 2y for output F_DO y (y = 0 ... 3) for test stop. The status of the LEDs also depends on the type of external circuit.					
DI 2y	–		Off	One of the two output lines y+ or y- or both lines of output y carry a signal	–
	Green		Continuous light	Both output lines y+ and y- carry no signal	–

<sup>1)</sup> Inputs x+1 (DI 1+, 3+, .. 19+) can be individually set using a parameter  
Additional information can be taken from the following reference:  
Reference: /LH1/ SINAMICS S120/S150 List Manual

### Cause and rectification of faults

Additional information about the cause and resolving faults can be taken from the following references:

- Reference:/LH1/SINAMICS S120/S150 List Manual
- Reference: /IH1/ SINAMICS S120 Commissioning Manual

5.5.5 Dimension drawing

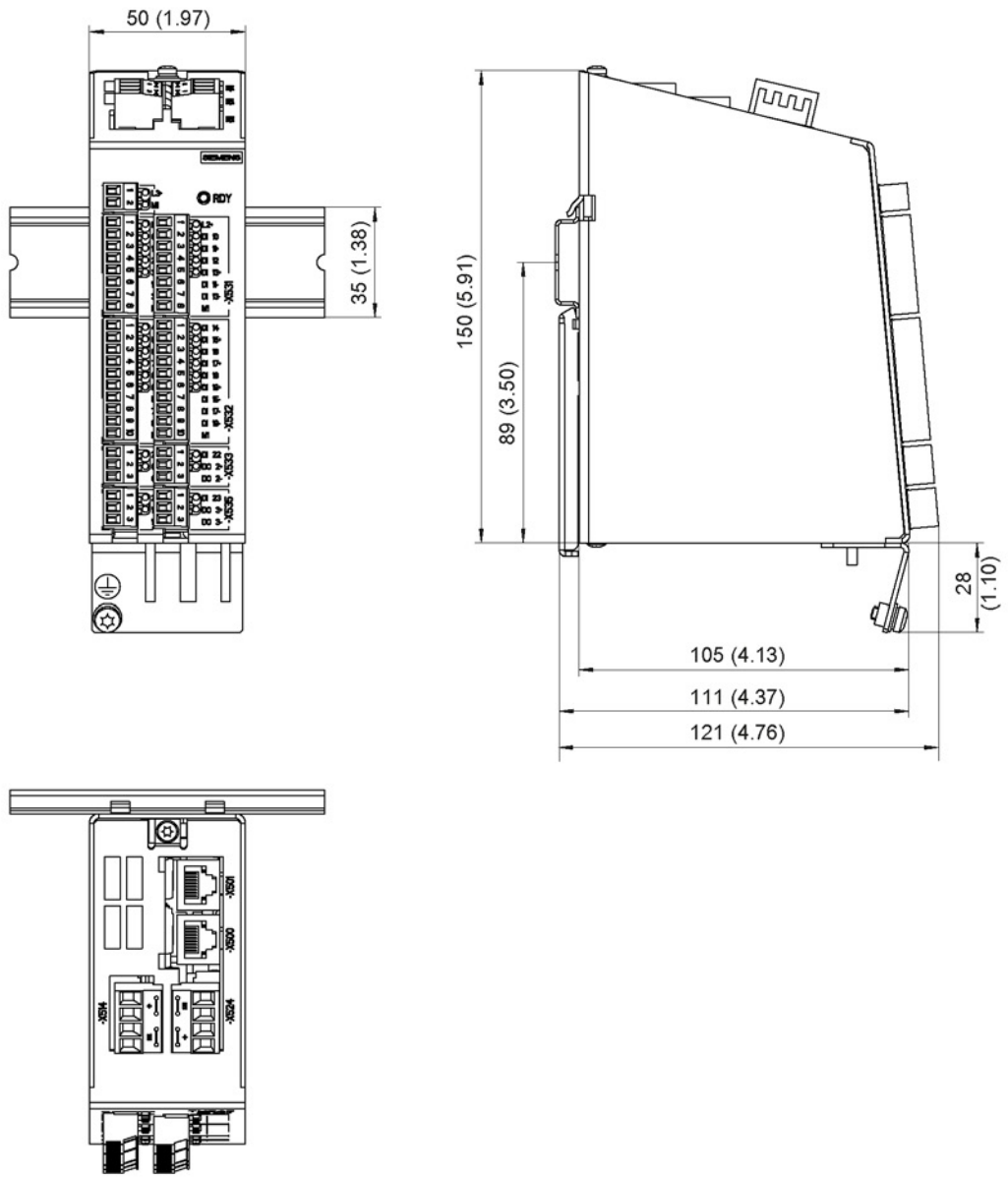

Figure 5-20 Dimension drawing of Terminal Module TM54F, all data in mm and (inches)

## 5.5.6 Installation

### Installation

1. Tilt the component backwards slightly and attach it to the DIN rail using the hooks.
2. Swivel the component onto the DIN rail until you hear the mounting slide at the rear latch into position.
3. Slide the component along the mounting rail to either the left or the right into its final position.

### Removal

1. First shift the mounting slide downwards at the lug to release the interlocking with the mounting rail.
2. Swivel the component to the front and withdraw it upwards from the DIN rail.

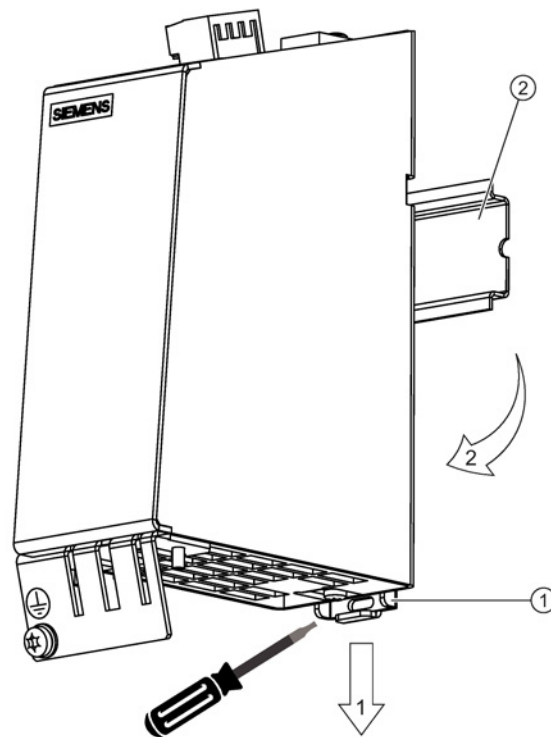

- ① Mounting slide
- ② Mounting rail

Figure 5-21 Removing from a DIN mounting rail

### 5.5.7 Protective conductor connection and shield support

It is always advisable to shield the digital input and output wiring.

The following diagram shows a typical Weidmüller shield connection clamp for the shield supports.

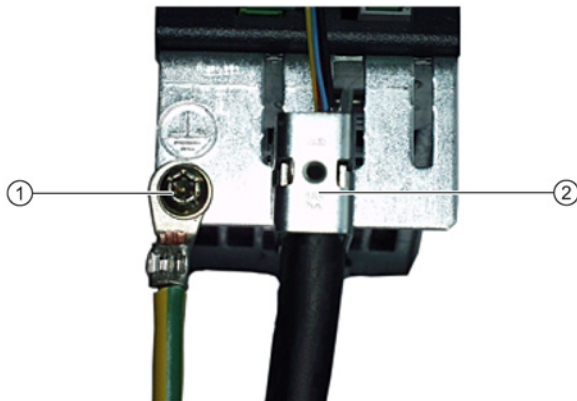

- ① Protective conductor connection M4 / 1.8 Nm
- ② Shield connection terminal, Weidmüller, type: KLBÜ CO1, Article No.: 1753311001

Figure 5-22 Shield support and protective conductor connection

#### NOTICE

##### Damage or faulty operation due to incorrect shielding or inadmissible cable lengths

If the correct shielding procedures or the permissible cable lengths are not observed, it can cause damage or the machine may malfunction.

- Only use shielded cables.
- Do not exceed the cable lengths stated in the technical data.

## 5.5.8 Technical data

Table 5- 45 Technical data

<b>6SL3055-0AA00-3BAx</b>	<b>Unit</b>	<b>Value</b>
<b>Current requirement X524</b> (at 24 V DC) without DRIVE-CLiQ supply	mA	160
<b>Current requirement X514</b> (at 24 V DC) without digital outputs and sensor power supply	mA	38
<b>Sensor power supply with and without forced dormant error detection (L1+, L2+, L3+)</b>		
Voltage	V	24
Max. load current per output	A	0.5
<b>Max. cable length for the 24 V supply:</b> For longer cable lengths, surge protection device "Weidmüller type No. MCZ OVP TAZ DIODE 24 VDC" should be used.	m	30
<b>Fail-safe digital inputs (F-DI) and standard digital inputs</b>		
Voltage	V	0 ... 30
Low level (an open digital input is interpreted as "low")	V	-3 ... +5
High level	V	15 ... 30
Current consumption (at 24 V DC)	mA	> 2
Input delay <sup>1)</sup> - For "0" to "1" - For "1" to "0"	µs µs	Approx. 30 (100 Hz) Approx. 60 (100 Hz)
<b>Fail-safe digital outputs (F-DO), continuous short-circuit proof</b>		
Voltage	V	24
Max. load current per digital output	A	0.5
Output delay <sup>1)</sup> - For "0" to "1" - For "1" to "0"	µs µs	300 350
<b>Power loss</b>	W	4.5 at 24 V
<b>PE/ground connection</b>		At the housing with M4 screw
<b>Weight</b>	kg	Approx. 0.9
<b>Degree of protection</b>	IP20	

<sup>1)</sup> Pure hardware delay

## 5.6 Terminal Module TM120

### 5.6.1 Description

The Terminal Module TM120 is a DRIVE-CLiQ component for safe electrically isolated temperature evaluation. It can be used for 1FN, 1FW6, and third-party motors in which the temperature sensors cannot be installed with safe electrical separation. The TM120 is installed in the control cabinet and can be snapped on to a DIN rail (EN 60715).

When a TM120 is being used, temperature evaluation and encoder evaluation functions are separated off from one another. The TM120 can detect the motor temperature via 4 channels with different temperature sensors. Encoder evaluation functions are performed via Sensor Modules (e.g. SMCxx, SMExx). This means that, when connected to a Sensor Module SMCxx, the TM120 represents a control cabinet alternative to the SME120/SME125.

The TM120 contains the following interfaces:

Table 5- 46 Overview of the TM120 interfaces

Type	Quantity
DRIVE-CLiQ interfaces	2
Temperature sensor inputs	4



## 5.6.2 Interface description

### 5.6.2.1 Overview

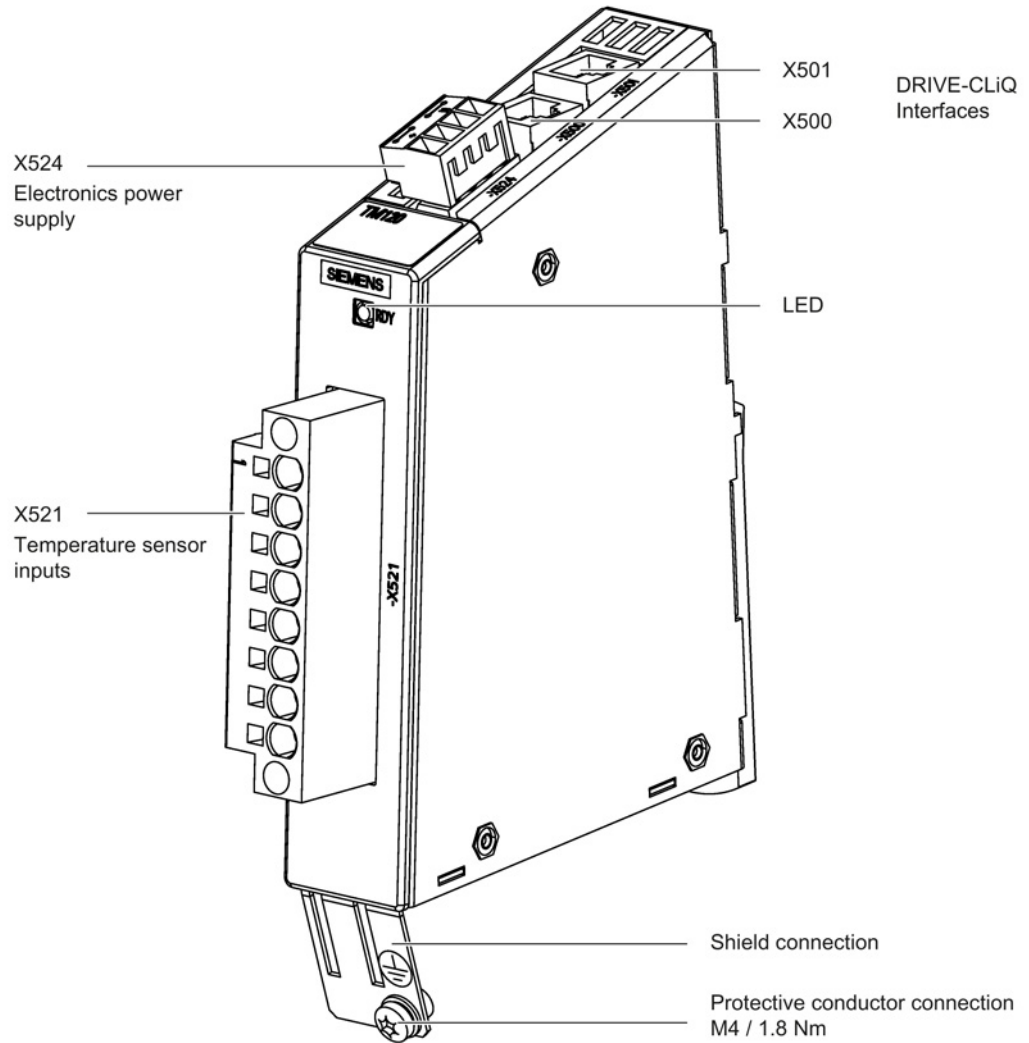
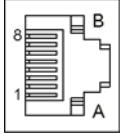

Figure 5-23 Interface overview TM120

5.6.2.2 X500/X501 DRIVE-CLiQ interfaces

Table 5- 47 X500/X501: DRIVE-CLiQ interfaces

	Pin	Signal name	Technical data
	1	TXP	Transmit data +
	2	TXN	Transmit data -
	3	RXP	Receive data +
	4	Reserved, do not use	
	5	Reserved, do not use	
	6	RXN	Receive data -
	7	Reserved, do not use	
	8	Reserved, do not use	
	A	+ (24 V)	Power supply
	B	M (0 V)	Electronics ground
	Connector type	RJ34plus socket	

The blanking covers for the DRIVE-CLiQ interfaces are included in the scope of delivery.

Blanking covers (50 x) Article No.: 6SL3066-4CA00-0AA0

**Note**

The maximum DRIVE-CLiQ cable length is 100 m.

### 5.6.2.3 X521 temperature sensor input

Table 5- 48 X521: Temperature sensor input

	Terminal	Function	Technical data
	1	- Temp	Temperature sensor connection KTY84-1C130/PTC/ bimetallic switch with NC contact In linear motor applications, connect the KTY84-1C130 motor temperature sensor here
	2	+ Temp	
	3	- Temp	Temperature sensor connection KTY84-1C130/PTC/ bimetallic switch with NC contact In linear motor applications, connect the PTC triple element 1 or bimetallic switch here
	4	+ Temp	
	5	- Temp	Temperature sensor connection KTY84-1C130/PTC/ bimetallic switch with NC contact In linear motor applications, connect the PTC triple element 2 here
	6	+ Temp	
	7	- Temp	Temperature sensor connection KTY84-1C130/PTC/ bimetallic switch with NC contact In linear motor applications, connect the PTC triple element 3 here
	8	+ Temp	

Type: Spring-loaded terminal 5 (Page 336)  
 Max. cross-section that can be connected: 6 mm<sup>2</sup>  
 Measuring current via the temperature sensor connection: 2 mA

**NOTICE**

**Damage when using a non-specified temperature sensor**

If sensors other than those specified are connected, this may result in incorrect measured values. Damage can result if overheating is not detected.

- Only connect temperature sensors that have been specified for operation with a TM120 Terminal Module.

**NOTICE**

**Overheating of the motor through jumpering the temperature sensor connections**

Jumpering of the temperature sensor connections "+ Temp" and "- Temp" results in incorrect measurement results. Damage to the motor can result if the overheating is not detected.

- When using several temperature sensors, separately connect the individual sensors to "+ Temp" and "- Temp".

The table below shows the preferable assignment of the connecting terminal for the temperature sensor input:

Table 5- 49 Preferable assignment, X521 temperature sensor input

Terminal	Signal name				Meaning
	1FW6	1FN3 (2x1FN3)	1FN1	Segment motor 4 segments	
1	KTY N	KTY N	KTY N	1 PTC 120 °C	KTY, negative pole
2	KTY P	KTY P	KTY P	1 PTC 120 °C	KTY, positive pole
3	PTC 130 °C	PTC 120 °C	Bimetallic switch with NC contact	2_PTC 120 °C	PTC triple element 1 or bimetallic switch with NC contact
4	PTC 130 °C	PTC 120 °C	Bimetallic switch with NC contact	2_PTC 120 °C	
5	PTC 150 °C	(2_KTY_N)		3_PTC 120 °C	PTC triple element 2
6	PTC 150 °C	(2_KTY_P)		3_PTC 120 °C	
7		(2 PTC 120 °C)		4 PTC 120 °C	PTC triple element 3
8		(2 PTC 120 °C)		4 PTC 120 °C	

The interconnection given is a suggestion (software default setting). Which temperature sensor is connected to which input can be freely configured.

#### NOTICE

##### Damage to motor in the event of incorrectly connected KTY temperature sensor

If a KTY temperature sensor is connected with incorrect polarity, it is not possible to detect when the motor overheats. Overheating can cause damage to the motor.

- Connect a KTY temperature sensor with the correct polarity.

#### Note

A 6FX7008-1BCx1 power cable is recommended for connecting the KTY temperature sensors.

#### Note

The maximum length of the temperature sensor cable is 100 m. The cables must be shielded.

### 5.6.2.4 X524 Electronics power supply

Table 5- 50 X524: Electronics power supply

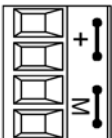
	Terminal	Designation	Technical data
	+	Electronics power supply	Voltage: 24 V DC (20.4 V – 28.8 V) Current consumption (max./typ.): 0.5 A / 0.1 A Max. current through the jumper in the connector: 20 A (15 A according to UL/CSA)
	+	Electronics power supply	
	M	Electronics ground	
	M	Electronics ground	
Type: Screw terminal 2 (Page 336)			

The maximum cable length that can be connected is 30 m.

#### Note

The two "+" or "M" terminals are jumpered in the connector. This ensures that the supply voltage is looped through.

The current consumption increases by the value for the DRIVE-CLiQ node.

### 5.6.3 Connection examples

Each TM120 is directly connected to an encoder evaluation unit (SMCxx or SMExx) by looping the corresponding DRIVE-CLiQ channel via the TM120. This ensures that encoders are automatically assigned to the temperature signals and, consequently, to the correct axis. The assignment can also be performed manually.

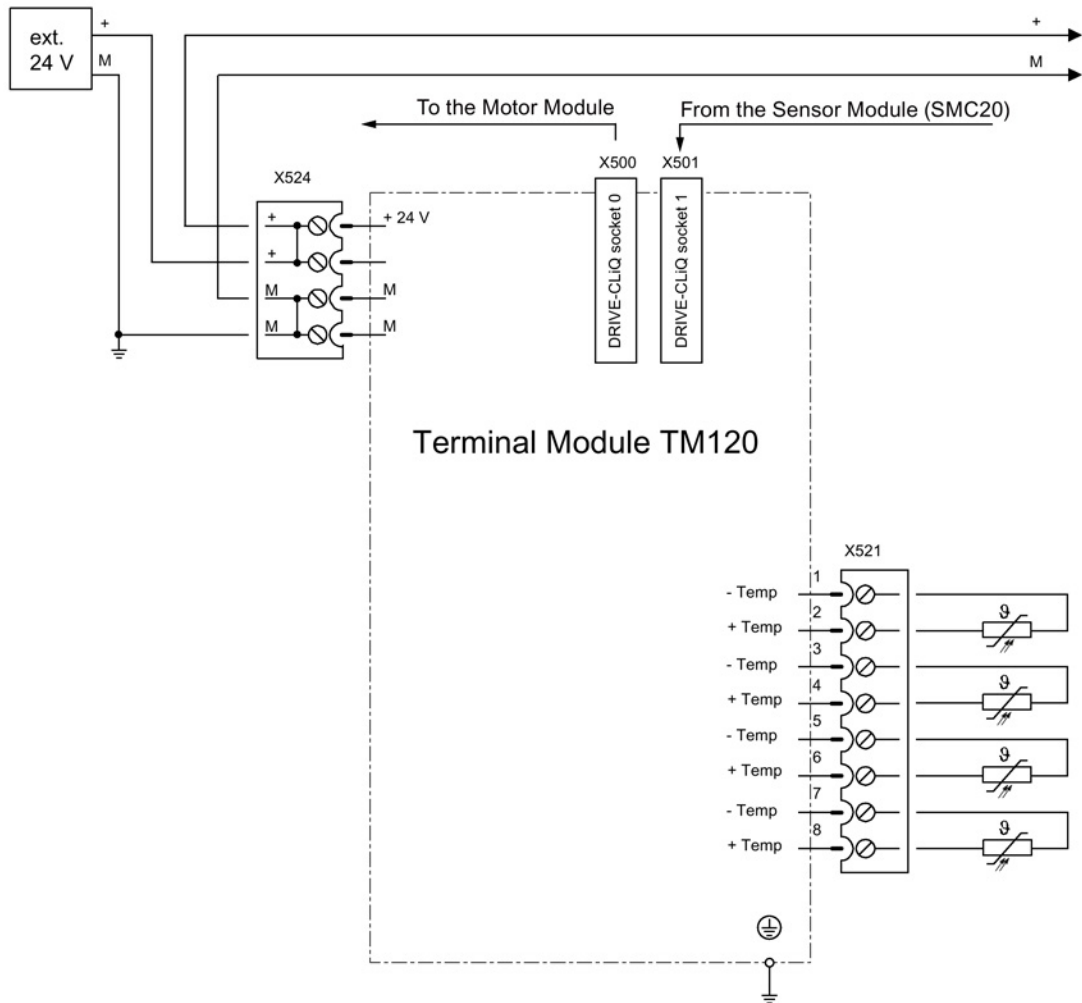

Figure 5-24 Connection example of TM120

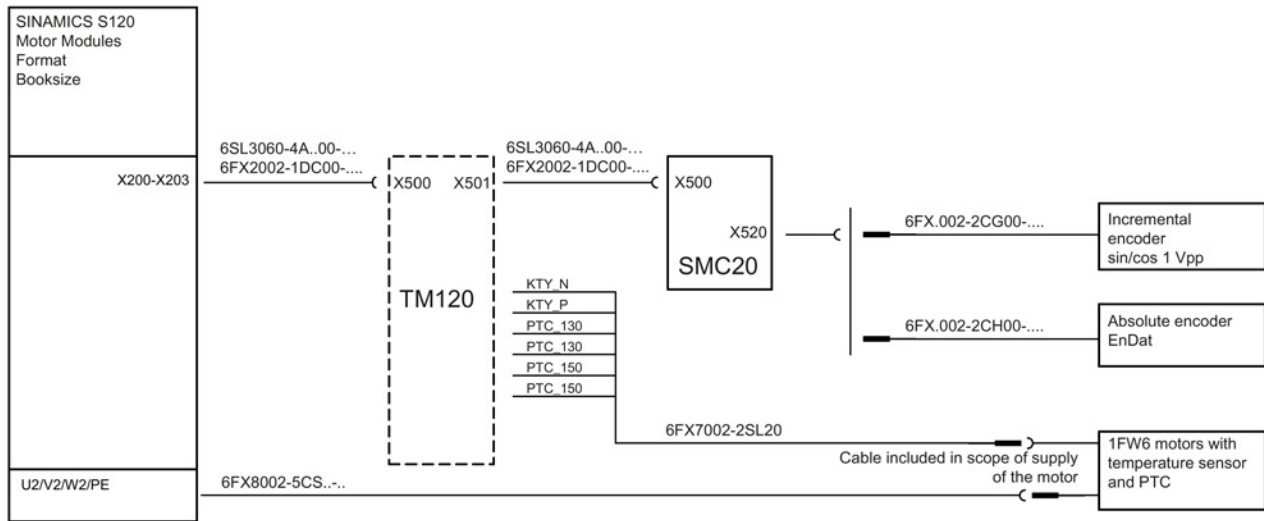

Figure 5-25 Connection example of TM120 with Motor Module and SMC20 (encoder evaluation)

## 5.6.4 Meaning of the LED

Table 5- 51 Meaning of the LEDs on the Terminal Module TM120

LED	Color	Status	Description, cause	Remedy
READY	-	Off	The electronics power supply is missing or outside the permissible tolerance range.	Check the power supply.
	Green	Continuous light	The component is ready for operation. Cyclic DRIVE-CLiQ communication is taking place.	-
	Orange	Continuous light	DRIVE-CLiQ communication is being established.	-
	Red	Continuous light	This component has at least one fault. <b>Note:</b> The LED is activated regardless of whether the corresponding messages have been reconfigured.	Remove and acknowledge the fault.
	Green/ red	Flashing light 0.5 Hz	Firmware is being downloaded.	-
		Flashing light 2 Hz	Firmware download is complete. The system waits for POWER ON.	Carry out a POWER ON.
Green/ orange or red/ orange	Flashing light 2 Hz	Detection of the components via LED is activated <sup>1)</sup> . <b>Note:</b> Both options depend on the LED status when activated.	-	

<sup>1)</sup> The parameters for activating component recognition using LEDs can be taken from the following reference:  
Reference: /LH1/ SINAMICS S120/S150 List Manual

### Cause and rectification of faults

Additional information about the cause and resolving faults can be taken from the following references:

- Reference: /LH1/SINAMICS S120/S150 List Manual
- Reference: /IH1/ SINAMICS S120 Commissioning Manual

### 5.6.5 Dimension drawing

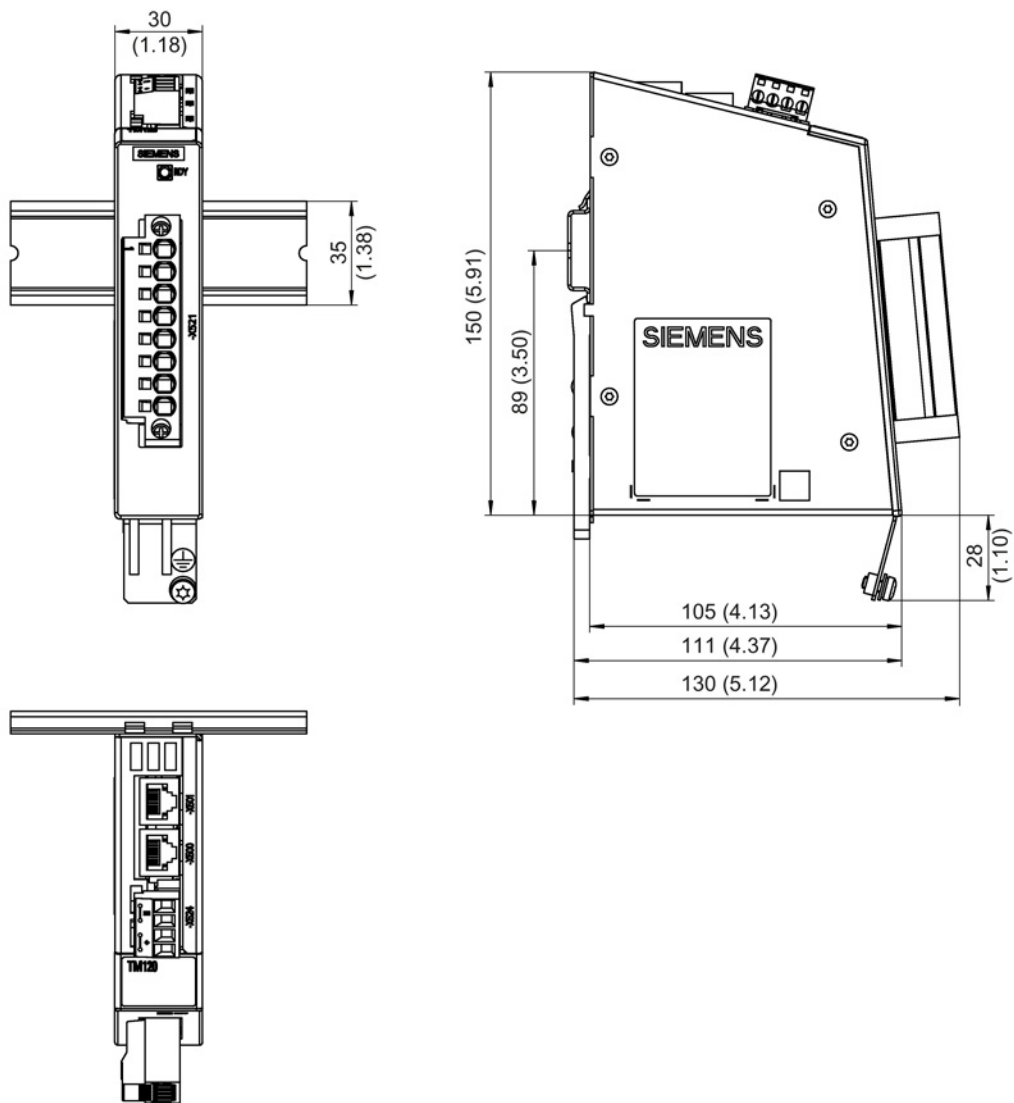

Figure 5-26 Dimension drawing of Terminal Module TM120, all data in mm and (inches)



## 5.6.6 Installation

### Installation

1. Tilt the component backwards slightly and attach it to the DIN rail using the hooks.
2. Swivel the component onto the DIN rail until you hear the mounting slide at the rear latch into position.
3. Slide the components along the mounting rail to either the left or right up to their final position.

### Removal

1. First shift the mounting slide downwards at the lug to release the interlocking with the mounting rail.
2. Swivel the component to the front and withdraw it upwards from the DIN rail.

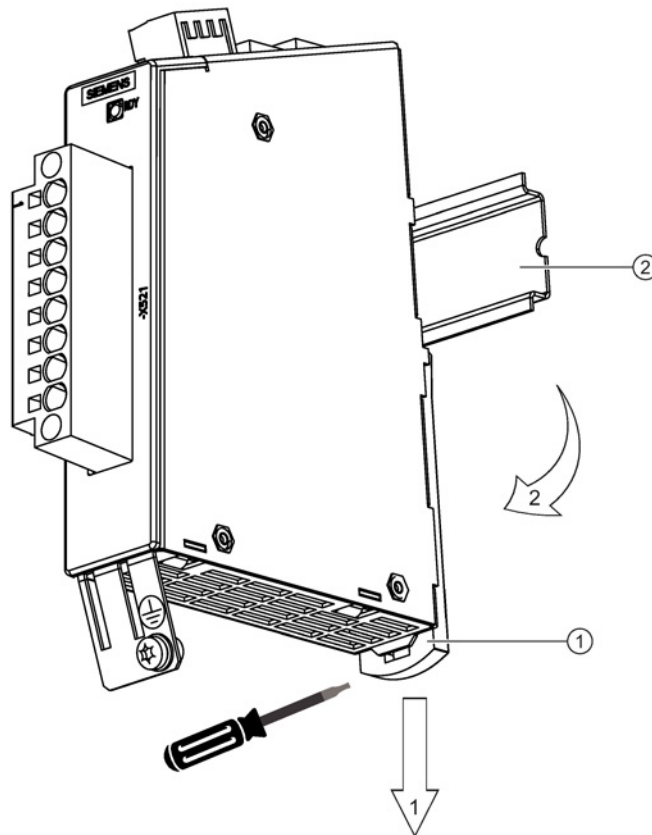

- ① Mounting slide  
② Mounting rail

Figure 5-27 Removal of a TM120 from a DIN rail

### 5.6.7 Protective conductor connection and shield support

The following diagram shows a typical Weidmüller shield connection clamp for the shield supports.

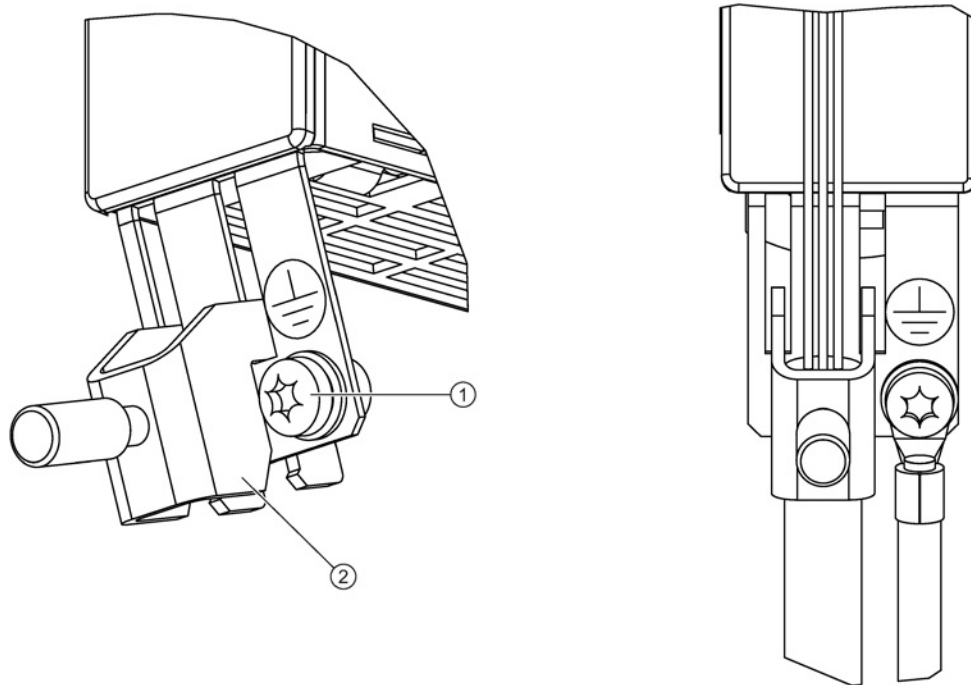

- ① Protective conductor connection M4 / 1.8 Nm
- ② Shield connection terminal, Weidmüller, type: KLBÜ CO1, Article No.: 1753311001

Figure 5-28 Shield support and protective conductor connection of the TM120

#### NOTICE

##### Damage or faulty operation due to incorrect shielding or inadmissible cable lengths

If the correct shielding procedures or the permissible cable lengths are not observed, it can cause damage or the machine may malfunction.

- Only use shielded cables.
- Do not exceed the cable lengths stated in the technical data.

## 5.6.8 Technical data

Table 5- 52 Technical data

6SL3055-0AA00-3KAx	Unit	Value
<b>Electronics power supply</b>		
Voltage	V <sub>DC</sub>	24 (20.4 ... 28.8)
Current (without DRIVE-CLiQ)	A <sub>DC</sub>	0.20 / 0.1 (typ.)
Power loss	W	2.4 (typ.)
Maximum cable length	m	30
PE/ground connection	At the housing with M4/1.8 Nm screw	
Weight	kg	0.41
Degree of protection	IP20	

## 5.7 Terminal Module TM150

### 5.7.1 Description

The terminal module TM150 is a DRIVE-CLiQ component for temperature evaluation. The temperature is measured in a temperature range from -99 °C to +250 °C for the following temperature sensors:

- PT100 (with monitoring for wire breakage and short-circuit)
- PT1000 (with monitoring for wire breakage and short-circuit)
- KTY84 (with monitoring for wire breakage and short-circuit)
- PTC (with short-circuit monitoring)
- Bimetallic NC contact (without monitoring)

For the temperature sensor inputs, for each terminal block the evaluation can be parameterized for 1x2-wire, 2x2-wire, 3-wire or 4-wire. There is no galvanic isolation in the TM150.

The TM150 is mounted in the control cabinet and can be snapped on to a standard mounting rail (EN 60715).

The TM150 contains the following interfaces:

Table 5- 53 Overview of the TM150 interfaces

Type	Quantity
DRIVE-CLiQ interfaces	2
Temperature sensor inputs	12
Electronics power supply	1

### 5.7.2 Interface description

#### 5.7.2.1 Overview

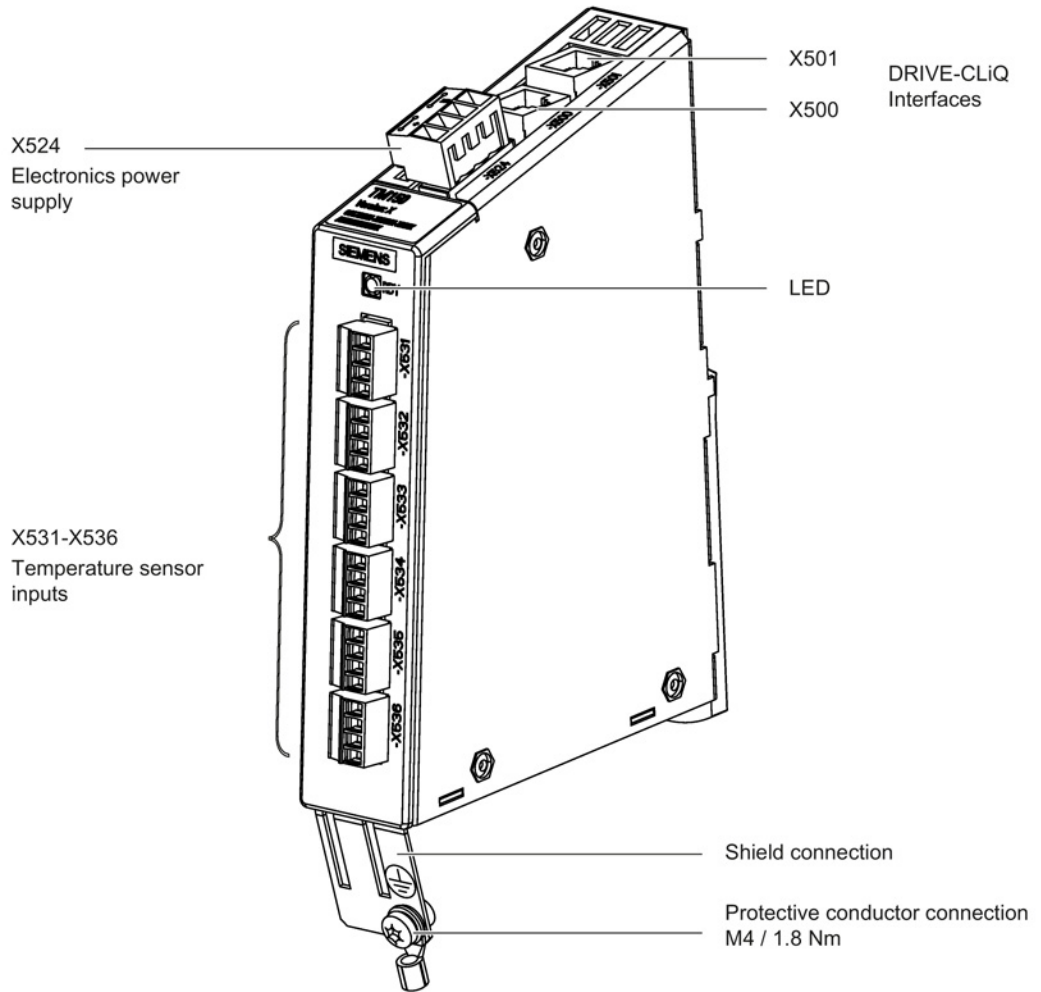
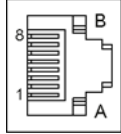

Figure 5-29 Interface overview of Terminal Module TM150

### 5.7.2.2 X500/X501 DRIVE-CLiQ interfaces

Table 5- 54 X500/X501: DRIVE-CLiQ interfaces

	Pin	Signal name	Technical data
	1	TXP	Transmit data +
	2	TXN	Transmit data -
	3	RXP	Receive data +
	4	Reserved, do not use	
	5	Reserved, do not use	
	6	RXN	Receive data -
	7	Reserved, do not use	
	8	Reserved, do not use	
	A	+ (24 V)	Power supply, max. 450 mA
	B	M (0 V)	Electronics ground
Connector type	DRIVE-CLiQ socket		

The blanking covers for the DRIVE-CLiQ interfaces are included in the scope of delivery.

Blanking covers (50 units), article number: 6SL3066-4CA00-0AA0

#### Note

The maximum DRIVE-CLiQ cable length is 100 m.

### 5.7.2.3 X524 Electronics power supply

Table 5- 55 X524: Electronics power supply

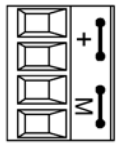
	Terminal	Designation	Technical data
	+	Electronics power supply	Voltage: 24 V DC (20.4 V – 28.8 V) Current consumption (max./typ.): 0.5 A / 0.1 A Max. current through the jumper in the connector: 20 A (15 A according to UL/CSA)
	+	Electronics power supply	
	M	Electronics ground	
	M	Electronics ground	
Type: Screw terminal 2 (Page 336)			

The maximum cable length that can be connected is 30 m.

#### Note

The two "+" or "M" terminals are jumpered in the connector. This ensures that the supply voltage is looped through.

The current consumption increases by the value for the DRIVE-CLiQ node.

## 5.7.2.4 X531-X536 temperature sensor inputs

Table 5- 56 X531-X536: Temperature sensor inputs

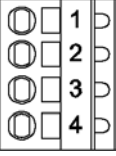
	Terminal	Function 1x2- / 2x2-wire	Function 3 and 4-wire	Technical data
	1	+ Temp (channel x)	+ (Channel x)	Temperature sensor connection for sensors with 1x2 wires Connection of the 2nd measuring cable for sensors with 4 wires.
	2	- Temp (channel x)	- (Channel x)	Temperature sensor connection for sensors with 1x2 wires Connection of the 1st measuring cable for sensors with 3 and 4 wires.
	3	+ Temp (channel y)	+ I <sub>c</sub> (constant current, positive channel x)	Temperature sensor connection for sensors with 2x2, 3 and 4-wires
	4	- Temp (channel y)	- I <sub>c</sub> (constant current, negative channel x)	
Type: Spring-loaded terminal 3 (Page 336) Max. cross-section that can be connected: 1.5 mm <sup>2</sup> Measuring current via temperature sensor connection: approx. 0.83 mA				

When connecting temperature sensors with 3 wires, a jumper must be inserted between X53x.2 and X53x.4.

Table 5- 57 Channel assignment

Terminal	Channel number [x] for 1x2, 3 and 4-wires	Channel number [y] for 2x2 wires
X531	0	6
X532	1	7
X533	2	8
X534	3	9
X535	4	10
X536	5	11

**NOTICE****Damage to motor in the event of incorrectly connected KTY temperature sensor**

If a KTY temperature sensor is connected with incorrect polarity, it is not possible to detect when the motor overheats. Overheating can cause damage to the motor.

- Connect a KTY temperature sensor with the correct polarity.

**NOTICE**

**Overheating of the motor through jumpering the temperature sensor connections**

Jumpering of the temperature sensor connections "+ Temp" and "- Temp" results in incorrect measurement results. Damage to the motor can result if the overheating is not detected.

- When using several temperature sensors, separately connect the individual sensors to "+ Temp" and "- Temp".

**NOTICE**

**Device failure as a result of unshielded or incorrectly routed cables to temperature sensors**

Unshielded or incorrectly routed cables to temperature sensors can result in interference being coupled into the signal processing electronics from the power side. This can result in significant disturbance of all signals (fault messages) up to failure of individual components (destruction of the devices).

- Only use shielded cables as temperature sensor cables.
- If temperature sensor cables are routed together with the motor cable, use separately shielded cables twisted in pairs.
- Connect the cable shield at both ends to ground potential through a large surface area.
- Recommendation: Use suitable Motion Connect cables.

**Note**

**Incorrect temperature measured values as a result of cables with an excessively high resistance**

An excessively long cable length or an excessively small cable cross-section can falsify the temperature measurement (for a PT100, 10  $\Omega$  cable resistance can falsify the measurement result by 10%). As a consequence, excessively high measured values are output, which could lead to the motor being unnecessarily tripped prematurely.

- Use only cable lengths  $\leq$  300 m.
- For cable lengths  $>$ 100 m, use cables with a cross-section of  $\geq$ 1 mm<sup>2</sup>.

### 5.7.3 Connection examples

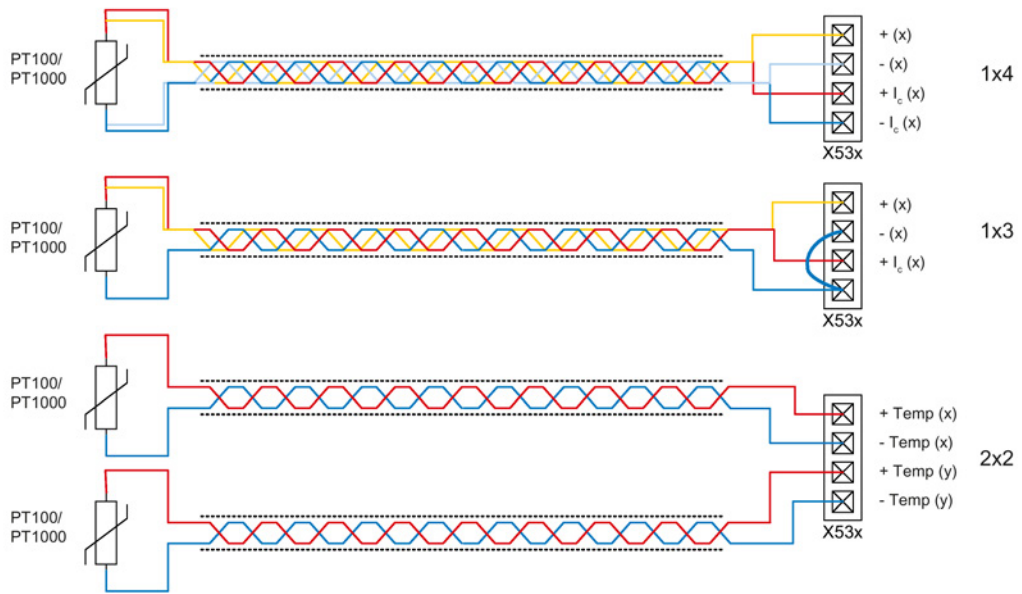

Figure 5-30 Connecting a PT100/PT1000 with 2x2, 3 and 4-wires to the temperature sensor inputs X53x of Terminal Module TM150



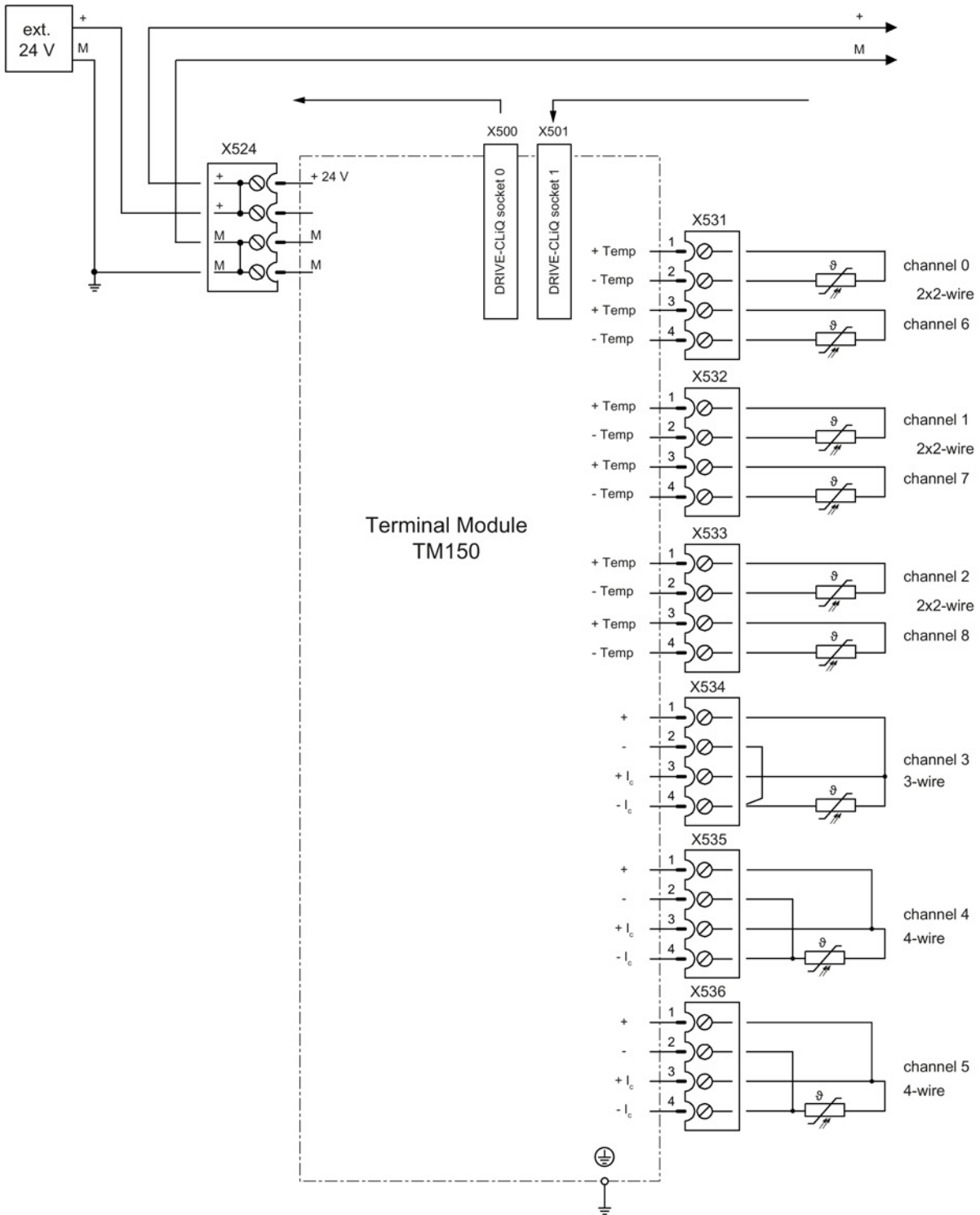

Figure 5-31 Connection example for a Terminal Module TM150

### 5.7.4 Meaning of the LED

Table 5- 58 Meaning of the LEDs at the Terminal Module TM150

LED	Color	Status	Description, cause	Remedy	
READY	–	Off	The electronics power supply is missing or outside the permissible tolerance range.	Check the power supply.	
	Green	Continuous light	The component is ready for operation and cyclic DRIVE-CLiQ communication is taking place.	–	
	Orange	Continuous light	DRIVE-CLiQ communication is being established.	–	
	Red	Continuous light	This component has at least one fault. <b>Note:</b> LED is controlled irrespective of the corresponding messages being reconfigured.	Remove and acknowledge the fault.	
	Green/red	Flashing light 0.5 Hz	Firmware is being downloaded.		–
			Firmware has been downloaded. The system waits for POWER ON.		Carry out a POWER ON
	Green/orange or red/orange	Flashing light 2 Hz	Component recognition via LED is activated <sup>1)</sup> . <b>Note:</b> Both options depend on the LED status when component recognition is activated.	–	

<sup>1)</sup> The parameters for activating component recognition using LEDs can be taken from the following reference:  
Reference: /LH1/ SINAMICS S120/S150 List Manual

#### Cause and rectification of faults

Additional information about the cause and resolving faults can be taken from the following references:

- Reference: /LH1/SINAMICS S120/S150 List Manual
- Reference: /IH1/ SINAMICS S120 Commissioning Manual

### 5.7.5 Dimension drawing

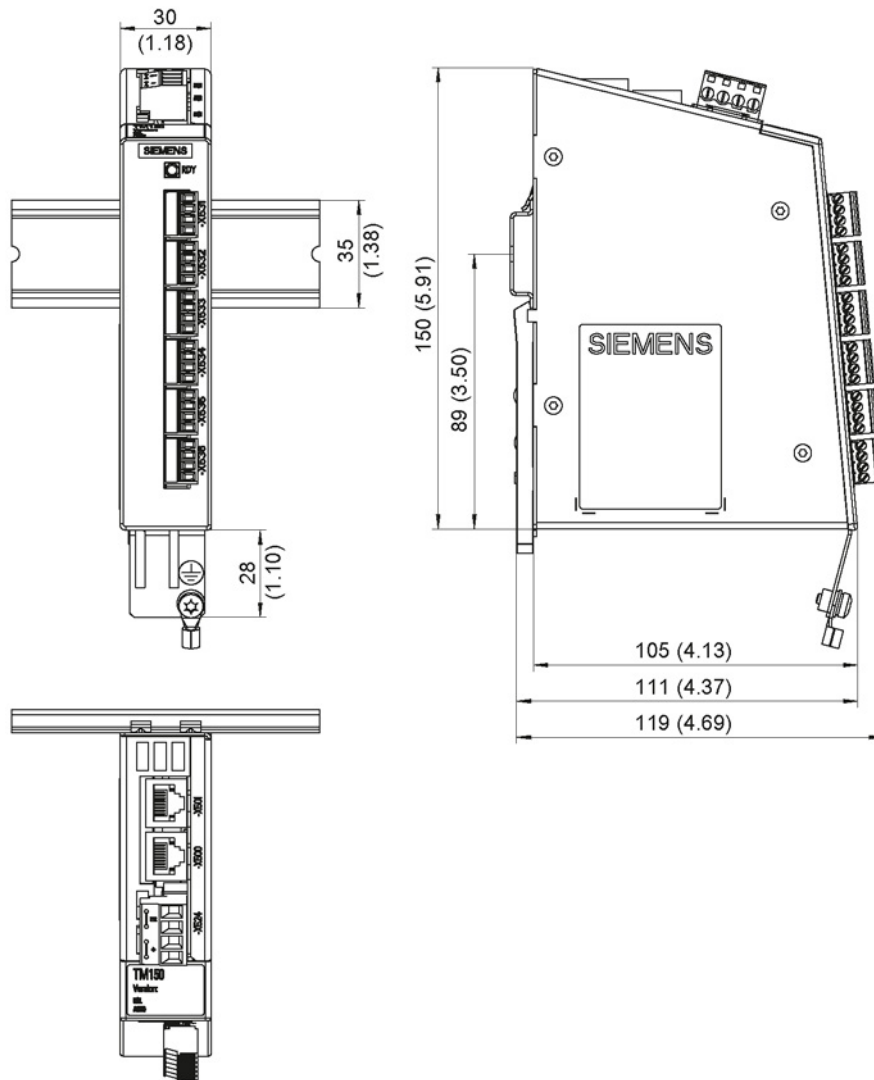

Figure 5-32 Dimension drawing of Terminal Module TM150, all data in mm and (inches)

### 5.7.6 Installation

#### Installation

1. Tilt the component backwards slightly and attach it to the DIN rail using the hooks.
2. Swivel the component onto the DIN rail until you hear the mounting slide at the rear latch into position.
3. Slide the components along the mounting rail to either the left or right up to their final position.

#### Removal

1. First shift the mounting slide downwards at the lug to release the interlocking with the mounting rail.
2. Swivel the component to the front and withdraw it upwards from the DIN rail.

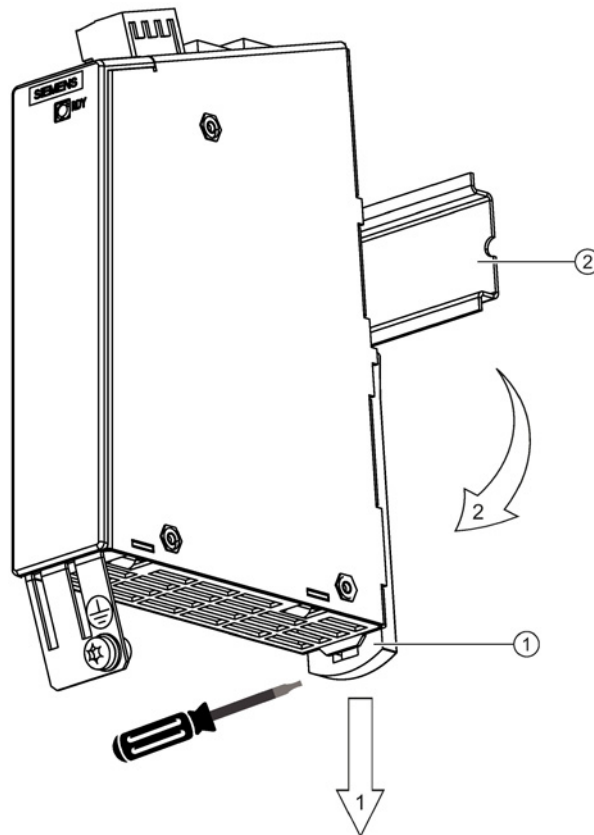

- ① Mounting slide
- ② Mounting rail

Figure 5-33 Removing a TM150 from a mounting rail

### 5.7.7 Protective conductor connection and shield support

The following diagram shows a typical Weidmüller shield connection clamp for the shield supports.

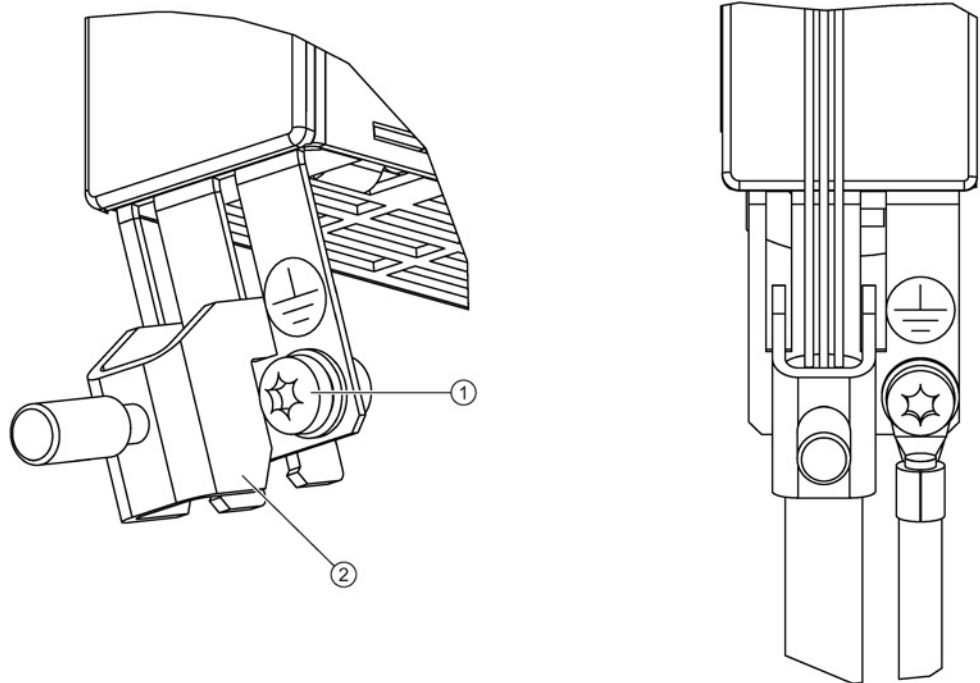

- ① Protective conductor connection M4 / 1.8 Nm
- ② Shield connection terminal, Weidmüller, type: KLBÜ CO1, Article No.: 1753311001

Figure 5-34 Shield support and protective conductor connection of the TM150

#### NOTICE

##### Damage or faulty operation due to incorrect shielding or inadmissible cable lengths

If the correct shielding procedures or the permissible cable lengths are not observed, it can cause damage or the machine may malfunction.

- Only use shielded cables.
- Do not exceed the cable lengths stated in the technical data.

## 5.7.8 Technical data

Table 5- 59 Technical data

6SL3055-0AA00-3LA0	Unit	Value
<b>Electronics power supply</b>		
Voltage	V <sub>DC</sub>	24 (20.4 ... 28.8)
Current (without DRIVE-CLiQ)	A <sub>DC</sub>	0.07
Power loss	W	1.6
Maximum cable length	m	30
PE/ground connection	At the housing with M4/1.8 Nm screw	
Weight	kg	0.4
Degree of protection	IP20	

## Hub Modules

### 6.1 Safety instructions for Hub Modules

 <b>WARNING</b>
<p><b>Danger to life if the fundamental safety instructions and remaining risks are not carefully observed</b></p> <p>If the fundamental safety instructions and remaining risks in Chapter 1 (Page 19) are not observed, accidents involving severe injuries or death may occur.</p> <ul style="list-style-type: none"> <li>• Adhere to the fundamental safety instructions.</li> <li>• When assessing the risk, take into account remaining risks.</li> </ul>

<b>NOTICE</b>
<p><b>Damage through use of incorrect DRIVE-CLiQ cables</b></p> <p>Damage or malfunctions can occur on the devices or system when incorrect or unreleased DRIVE-CLiQ cables are used.</p> <ul style="list-style-type: none"> <li>• Only use suitable DRIVE-CLiQ cables that have been released by Siemens for the respective application.</li> </ul>

---

#### Note

##### Function equipotential bonding for distributed DRIVE-CLiQ nodes

Integrate all of the components that are connected via DRIVE-CLiQ in the functional equipotential bonding concept. The connection should be preferably established by mounting on metallic bare machine and plant components that are connected with one another using an equipotential bonding conductor.

Alternatively, you can establish equipotential bonding using a conductor (min. 6 mm<sup>2</sup>), which as far as possible, is routed in parallel to the DRIVE-CLiQ cable. All distributed DRIVE-CLiQ nodes are involved, for example DMx20, SME2x, SM12x etc.

---

#### Note

##### Malfunctions due to polluted DRIVE-CLiQ interfaces

Malfunctions can occur in the system through the use of polluted DRIVE-CLiQ interfaces.

- Cover unused DRIVE-CLiQ interfaces with the supplied blanking covers.
-

## 6.2 DRIVE-CLiQ Hub Module DMC20

### 6.2.1 Description

The DRIVE-CLiQ Hub Module DMC20 is an expansion module for snapping on to a standard mounting rail acc. to EN 60715. It is used to distribute a DRIVE-CLiQ line with a star-type topology. With the DMC20, an axis grouping can be expanded with 5 DRIVE-CLiQ sockets for additional subgroups.

The component is especially suitable for applications which require DRIVE-CLiQ nodes to be removed in groups, without interrupting the DRIVE-CLiQ line and, therefore, the data exchange process.

 **WARNING**

**Risk of fire through overheating if there are insufficient ventilation clearances**

Insufficient ventilation clearances lead to overheating with associated risk to persons as a result of smoke and fire. This can also result in more downtimes and a reduced service life for the Hub Module.

- For this reason, it is imperative that you maintain the 50 mm clearances above and below the Hub Module.



## 6.2.2 Interface description

### 6.2.2.1 Overview

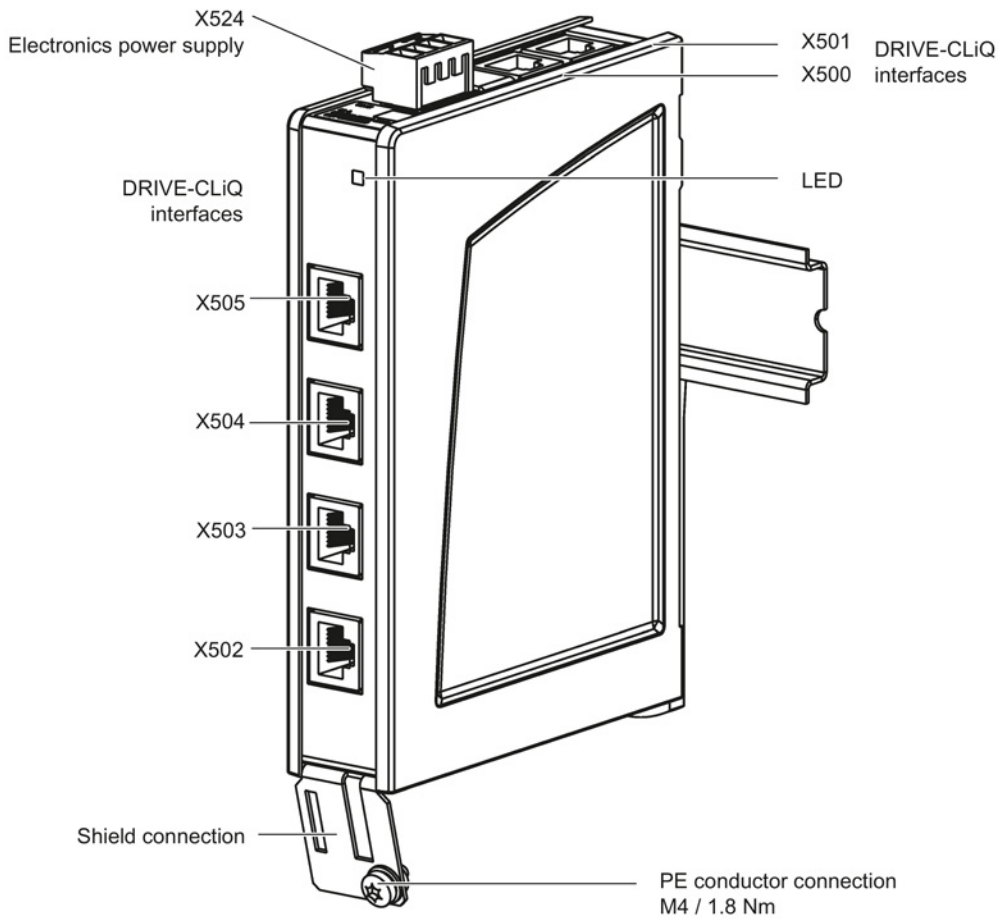
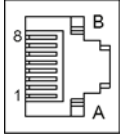

Figure 6-1 Interface overview of the DMC20

6.2.2.2 X500-X505 DRIVE-CLiQ interfaces

Table 6- 1 X500-X505: DRIVE-CLiQ interfaces

	Pin	Signal name	Technical data
	1	TXP	Transmit data +
	2	TXN	Transmit data -
	3	RXP	Receive data +
	4	Reserved, do not use	
	5	Reserved, do not use	
	6	RXN	Receive data -
	7	Reserved, do not use	
	8	Reserved, do not use	
	A	+ (24 V)	Power supply
	B	M (0 V)	Electronics ground
Connector type	DRIVE-CLiQ socket		

The blanking covers for the DRIVE-CLiQ interfaces are included in the scope of delivery.

Blanking covers (50 x) Article No.: 6SL3066-4CA00-0AA0

**Note**

Only MOTION-CONNECT DRIVE-CLiQ cables may be used to establish connections. The maximum length of MOTION-CONNECT 500 is 100 m and for MOTION-CONNECT 800PLUS cables, 75 m.

6.2.2.3 X524 Electronics power supply

Table 6- 2 X524: Electronics power supply

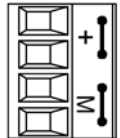
	Terminal	Designation	Technical data
	+	Electronics power supply	Voltage: 24 V DC (20.4 ... 28.8 V) Current consumption: max. 2.4 A Max. current through the jumper in the connector: 20 A (15 A according to UL/CSA)
	+	Electronics power supply	
	M	Electronics ground	
	M	Electronics ground	
Type: Screw terminal 2 (Page 336)			

The maximum cable length that can be connected is 30 m.

**Note**

The two "+" or "M" terminals are jumpered in the connector. This ensures that the supply voltage is looped through.

The current consumption increases by the value for the DRIVE-CLiQ participants.

### 6.2.3 Meaning of the LED

Table 6- 3 Description of the LEDs on the DRIVE-CLiQ Hub Module DMC20

LED	Color	Status	Description, cause	Remedy	
READY	–	Off	The electronics power supply is missing or outside the permissible tolerance range.	–	
	Green	Continuous light	The component is ready for operation. Cyclic DRIVE-CLiQ communication is taking place.	–	
	Orange	Continuous light	DRIVE-CLiQ communication is being established.	–	
	Red	Continuous light	This component has at least one fault. <b>Note:</b> LED is controlled irrespective of the corresponding messages being reconfigured.	Remove and acknowledge the fault.	
	Green/red	Flashing light 0.5 Hz	Firmware is being downloaded.		–
			Firmware download is complete. The system waits for POWER ON.		Carry out a POWER ON.
	Green/orange or Red/orange	Flashing light	Component recognition via LED is activated <sup>1)</sup> . <b>Note:</b> Both options depend on the LED status when component recognition is activated.	–	

<sup>1)</sup> The parameters for activating component recognition using LEDs can be taken from the following reference:  
Reference: /LH1/ SINAMICS S120/S150 List Manual

#### Cause and rectification of faults

Additional information about the cause and resolving faults can be taken from the following references:

- Reference: /LH1/SINAMICS S120/S150 List Manual
- Reference: /IH1/ SINAMICS S120 Commissioning Manual

### 6.2.4 Dimension drawing

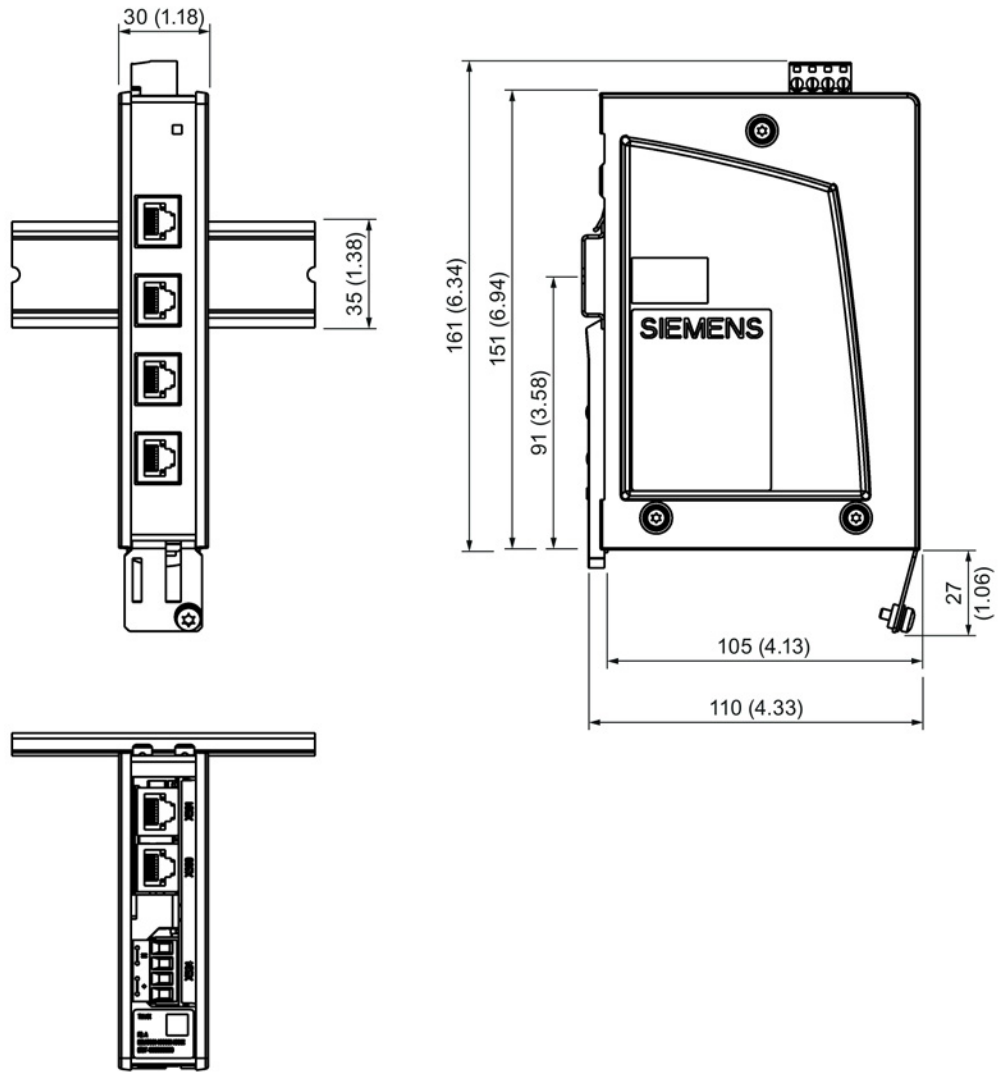

Figure 6-2 Dimension drawing of the DRIVE-CLiQ Hub Module DMC20, all data in mm and (inches)

## 6.2.5 Installation

### Installation

1. Tilt the component backwards slightly and attach it to the DIN rail using the hooks.
2. Swivel the component onto the DIN rail until you hear the mounting slide at the rear latch into position.
3. Slide the components along the mounting rail to either the left or right up to their final position.

## Removal

1. First shift the mounting slide downwards at the lug to release the interlocking with the mounting rail.
2. Swivel the component to the front and withdraw it upwards from the DIN rail.

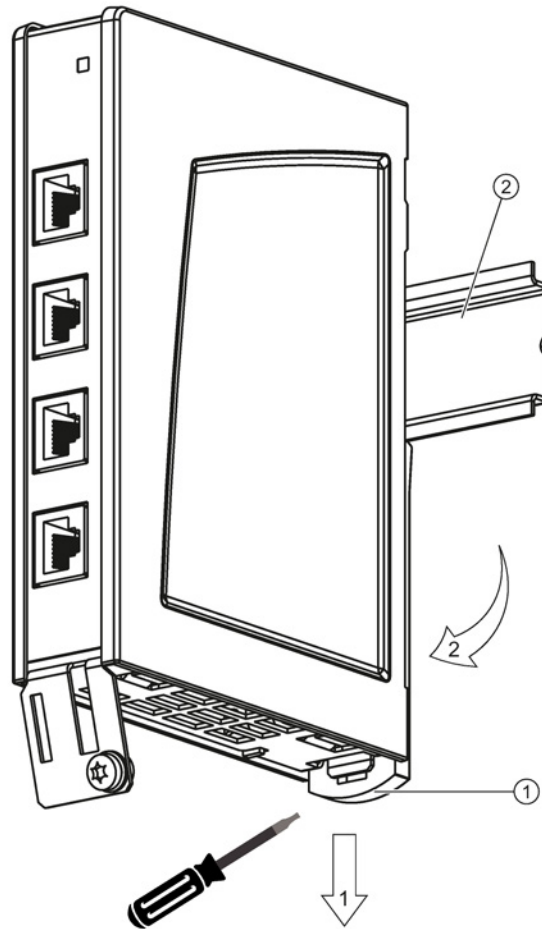

- ① Mounting slide
- ② Mounting rail

Figure 6-3 Removing from a DIN mounting rail

## 6.2.6 Protective conductor connection and shield support

The following diagram shows a typical Weidmüller shield connection clamp for the shield supports.

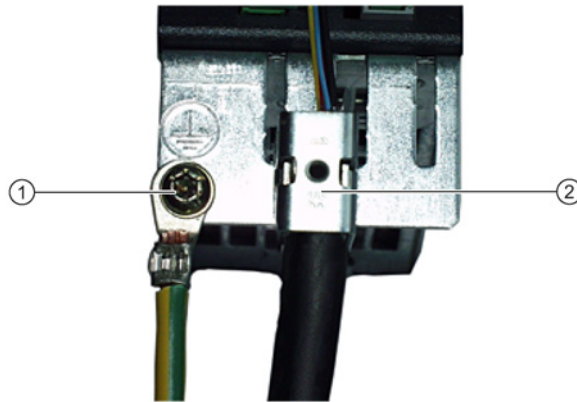

- ① Protective conductor connection M4 / 1.8 Nm
- ② Shield connection terminal, Weidmüller, type: KLBÜ CO1, Article No.: 1753311001

Figure 6-4 Shield support and protective conductor connection

### NOTICE

#### Damage or faulty operation due to incorrect shielding or inadmissible cable lengths

If the correct shielding procedures or the permissible cable lengths are not observed, it can cause damage or the machine may malfunction.

- Only use shielded cables.
- Do not exceed the cable lengths stated in the technical data.

## 6.2.7 Technical data

Table 6- 4 Technical data of the DMC20

6SL3055-0AA00-6AA1	Unit	Value
<b>Electronics power supply</b>		
Voltage	V <sub>DC</sub>	24 V DC (20.4 ... 28.8)
Current (without DRIVE-CLiQ node)	A <sub>DC</sub>	0.15
Maximum cable length	m	30
PE/ground connection	At the housing with M4/1.8 Nm screw	
Weight	kg	0.36

## 6.3 DRIVE-CLiQ Hub Module External DME20

### 6.3.1 Description

The DRIVE-CLiQ Hub Module External DME20 is used to implement star-shaped distribution of a DRIVE-CLiQ line. With the DME20, an axis grouping can be expanded with 5 DRIVE-CLiQ sockets for additional subgroups.

The component has degree of protection IP67 and is especially suitable for applications which require DRIVE-CLiQ nodes to be removed in groups, without interrupting the DRIVE-CLiQ line and therefore the data exchange.

<b>NOTICE</b>
<b>Damage due to leaking plug connections</b>
If IP67 protection is not ensured, water or dirt can enter and lead to damage.
<ul style="list-style-type: none"><li>• Ensure that all connectors are correctly screwed into place and appropriately locked.</li></ul>



6.3.2 Interface description

6.3.2.1 Overview

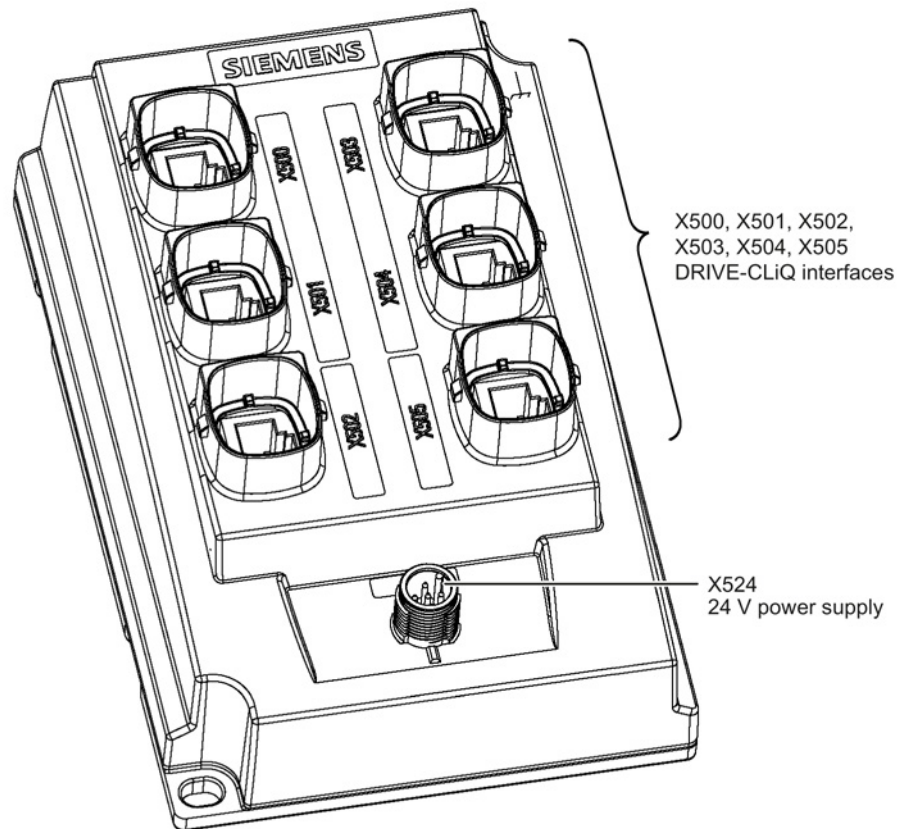
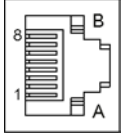

Figure 6-5 Interface overview of the DME20

6.3.2.2 X500-X505 DRIVE-CLiQ interfaces

Table 6- 5 X500-X505: DRIVE-CLiQ interfaces

	Pin	Signal name	Technical data
	1	TXP	Transmit data +
	2	TXN	Transmit data -
	3	RXP	Receive data +
	4	Reserved, do not use	
	5	Reserved, do not use	
	6	RXN	Receive data -
	7	Reserved, do not use	
	8	Reserved, do not use	
	A	+ (24 V)	Power supply
	B	M (0 V)	Electronics ground
Connector type	DRIVE-CLiQ socket		

The blanking covers for the DRIVE-CLiQ interfaces are included in the scope of delivery.

Blanking covers (6 units), article number: 6SL3066-4CA01-0AA0

**Note**

Only MOTION-CONNECT DRIVE-CLiQ cables may be used to establish connections. The maximum length of MOTION-CONNECT 500 is 100 m and for MOTION-CONNECT 800PLUS cables, 75 m.

6.3.2.3 X524 Electronics power supply

Table 6- 6 X524: Electronics power supply

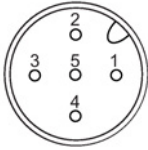
	Pin	Designation	Technical data
	1	Electronics power supply	The connection voltage of 20.4 V to 28.8 V refers to the (terminal) voltage at the DME20. This must be taken into account when selecting the cable cross-section and supply cable lengths. Pins 1 and 2: jumpered internally Pins 3 and 4: jumpered internally
	2	Electronics power supply	
	3	Electronics ground	
	4	Electronics ground	
	5	not connected	
5-pin socket, max. connectable cross-section: 4 x 0.75 mm <sup>2</sup>			

**Note**

The maximum cable length for the 24 V supply of the DME20 is 100 m.

If a UL-compliant design is not required, the use of the following cables and connectors from Siemens is recommended:

**Pre-assembled cables**

Connecting cable for power supply with M12 plug and M12 socket,  
A-coded, 4-pin,  
Article number: 6XV1801-5D..

**Cables to be assembled by the user**

Cable	Connector
24 V DC cable, 2-wire, 2 x 0.75 mm <sup>2</sup> , Article number: 6XV1812-8A	M12 plug connector, 4-pin, A-coded, Article number: 6GK1907-0DC10-6AA3

Table 6- 7 Cable length P24 supply cable

Connected loads <sup>1)</sup> m	1	2	3	4	5
<b>Cross-section</b>					
0.34 mm <sup>2</sup>	75 m	45 m	30 m	25 m	20 m
2 x 0.34 mm <sup>2</sup>	100 m	90 m	65 m	50 m	40 m
0.75 mm <sup>2</sup>	100 m	100 m	75 m	60 m	50 m
2 x 0.75 mm <sup>2</sup>	100 m	100 m	100 m	100 m	100 m
T <sub>a</sub> = 55 °C 100 m DRIVE-CLiQ					

<sup>1)</sup> Connected motors with DRIVE-CLiQ encoder, DRIVE CLiQ mounted encoder SME

### 6.3.3 Dimension drawing

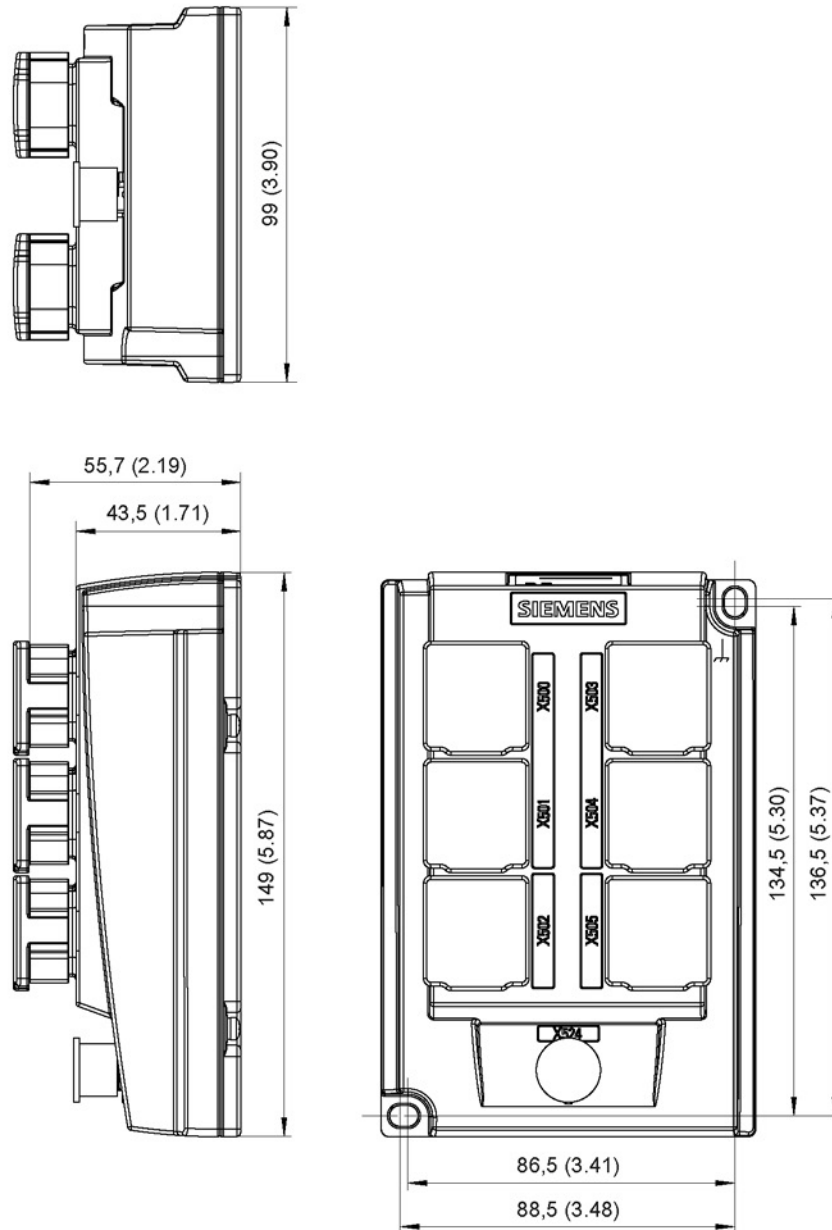
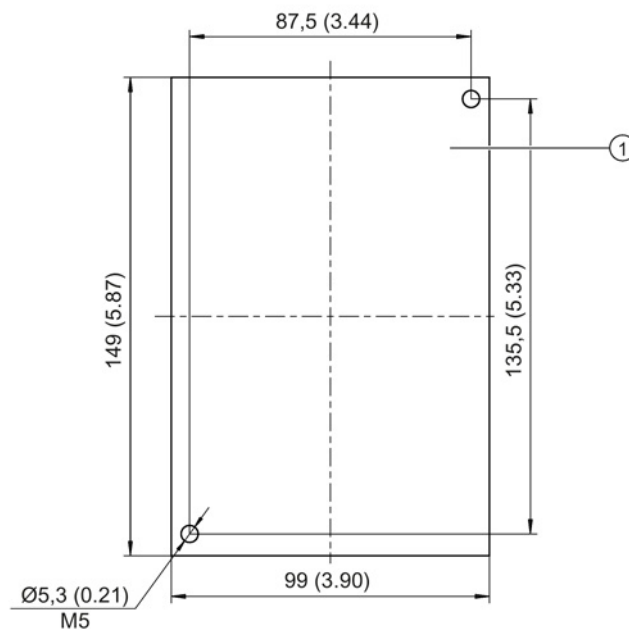

Figure 6-6 Dimension drawing of the DRIVE-CLiQ Hub Module External DME20, all data in mm and (inches)

## 6.3.4 Installation



① Contact surface

Figure 6-7 Mounting dimensions DME20

## Installation

1. Place the drilling pattern on the mounting surface. Make sure that the contact surface is bare, unpainted metal.
2. Drill two holes with  $\varnothing 5.3$  or M5 threaded holes according to the drilling pattern.
3. Mount the DME20 DRIVE-CLiQ Hub Module External on the contact surface. The tightening torque is 6.0 Nm.

## 6.3.5 Technical data

Table 6- 8 Technical data of the DME20

6SL3055-0AA00-6ABx	Unit	Value
Electronics power supply		
Voltage	$V_{DC}$	24 (20.4 ... 28,8)
Current (without DRIVE-CLiQ node)	$A_{DC}$	0.15
PE/ground connection	Screwed to the housing M5 / 6 Nm	
Degree of protection		IP67
Weight	kg	0.8

### 6.3.6 Specifications for use with UL approval

**Pre-assembled cables**

Sensor/actuator cable, 5-pin, variable cable,  
 free cable end at straight socket M12-SPEEDCON,  
 cable length: 2, 5, 10, 15 m  
 SAC-5P-xxx-186/FS SCO  
 Up to 100 m on request

Company Phoenix Contact

**Cables to be assembled by the user**

Cable	Connector
Cable coil, black PUR/PVC, 5-pin Conductor colors: brown/white/blue/black/gray Cable length: 100 m SAC-5P-100.0-186/0.75 Article number: 1535590	Sensor/actuator connector, socket, straight, 5-pin, M12, A-coded Screw connection, metal knurl, cable gland Pg9 SACC-M12FS-5CON-PG9-M Article number: 1681486
Company Phoenix Contact	

**Power supply**

The DME20 must use one of the following 24 V power supplies with voltage limiting:

- SITOP 6EP1x.. or 6ES7307..
- SINAMICS Control Supply Module 6SL3100-1DE22-0Axx

**Pin assignment of the cable**

Table 6- 9 Connection to X524 electronics power supply

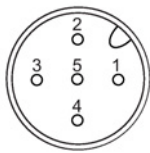
	Pin	Designation	Technical data
	1 (brown) <sup>1)</sup>	Electronics power supply	The supply voltage of 20.4 V ... 28.8 V refers to the (terminal) voltage at the DME20. This must be taken into account when selecting the cable cross-section and supply cable lengths. Pins 1 and 2: jumpered internally Pins 3 and 4: jumpered internally
	2 (white) <sup>1)</sup>	Electronics power supply	
	3 (black) <sup>1)</sup>	Electronics ground	
	4 (blue) <sup>1)</sup>	Electronics ground	
	5 (gray) <sup>1)</sup>	Not connected internally	

<sup>1)</sup> The colors refer to the cable specified above

## Voltage Sensing Module VSM10

### 7.1 Description

The Voltage Sensing Module VSM10 is an expansion module for snapping on to a standard mounting rail acc. to EN 60715. It is used to sense the actual value of a voltage. For example, it can be used to sense the three-phase line supply voltage, which is then provided to the closed-loop control. The phase differential voltage can be measured, either grounded (in the delivery state) or isolated.

The Voltage Sensing Module can be used for the following line types:

- Up to 600 V 3-ph. AC for all line types
- Up to 690 V 3-ph. AC for networks with grounded start point and IT networks

A 100 V 3-ph. AC input is available for transducer transformers. It is not permissible to use both voltage connections simultaneously!

For booksize units, these components can be optionally used to increase the degree of ruggedness against irregularities in the line supply.

A VSM is already integrated for Active Interface Modules Chassis and Smart Line Modules Chassis.

In addition to the voltage sensing, a temperature sensor can be connector to the VSM10 to thermally monitor the line reactor. Further, the functionality of the line filter can checked using two analog inputs. All data recorded are transferred to the higher-level system via DRIVE-CLiQ.

The Voltage Sensing Module achieves radio interference category C2 with limit classes A1 for interference voltage and A for emitted interference.

Table 7- 1 Interface overview of the VSM10

Type	Quantity
Analog inputs	2
Voltage connection (690 V)	1 (3-phase)
Voltage connection (100 V)	1 (3-phase)
Temperature sensor input (KTY/PTC)	1
Neutral point grounding	1
DRIVE-CLiQ interface	1

## 7.2 Safety instructions for the Voltage Sensing Module (VSM10)

### WARNING

#### **Danger to life if the fundamental safety instructions and remaining risks are not carefully observed**

If the fundamental safety instructions and remaining risks in Chapter 1 (Page 19) are not observed, accidents involving severe injuries or death may occur.

- Adhere to the fundamental safety instructions.
- When assessing the risk, take into account remaining risks.

### WARNING

#### **Risk of fire through overheating if there are insufficient ventilation clearances**

Insufficient ventilation clearances lead to overheating with associated risk to persons as a result of smoke and fire. This can also result in more downtimes and reduced service lives of the Voltage Sensing Module.

- For this reason, it is imperative that you maintain the 50 mm clearances above and below the Voltage Sensing Module.

### NOTICE

#### **Destruction of the VSM10 as a result of voltage measurements incorrectly carried out**

If the voltage measurement is carried out incorrectly, the VSM10 can be destroyed as a result of the high voltage stress across the insulating clearance.

- When using long motor cables, it is not permissible that the output voltage of the Motor Module is directly measured at the motor.

### NOTICE

#### **Destruction of the VSM10 as a result of a terminal assignment which is not permissible**

The VSM10 has two terminal strips, X521 and X522, to sense the three-phase line supply voltage. A terminal assignment which is not permissible results in the module being destroyed.

- Use just one of the two terminal strips.
- Only connect voltages to terminal strip X521 up to a maximum 100 V (phase-to-phase) via a transformer.
- Only connect voltages to terminal strip X522 up to a maximum 690 V (phase-to-phase) directly.



**NOTICE****Damage through use of incorrect DRIVE-CLiQ cables**

Damage or malfunctions can occur on the devices or system when incorrect or unreleased DRIVE-CLiQ cables are used.

- Only use suitable DRIVE-CLiQ cables that have been released by Siemens for the respective application.

**Note****Function equipotential bonding for distributed DRIVE-CLiQ nodes**

Integrate all of the components that are connected via DRIVE-CLiQ in the functional equipotential bonding concept. The connection should be preferably established by mounting on metallic bare machine and plant components that are connected with one another using an equipotential bonding conductor.

Alternatively, you can establish equipotential bonding using a conductor (min. 6 mm<sup>2</sup>), which as far as possible, is routed in parallel to the DRIVE-CLiQ cable. All distributed DRIVE-CLiQ nodes are involved, for example DMx20, SME2x, SM12x etc.

**Note****Malfunctions due to polluted DRIVE-CLiQ interfaces**

Malfunctions can occur in the system through the use of polluted DRIVE-CLiQ interfaces.

- Cover unused DRIVE-CLiQ interfaces with the supplied blanking covers.

**Note****Malfunctions when using various generations of the VSM10 with parallel infeed**

When connecting infeeds in parallel, only Voltage Sensing Modules of the same generation may be used (either 6SL3053-0AA00-3AA0 or 6SL3053-0AA00-3AA1), as otherwise malfunctions can occur.

- Especially when replacing a VSM10 (Page 224) it is important that all of the other VSM10 connected in parallel are replaced.

## 7.3 Interface description

### 7.3.1 Overview

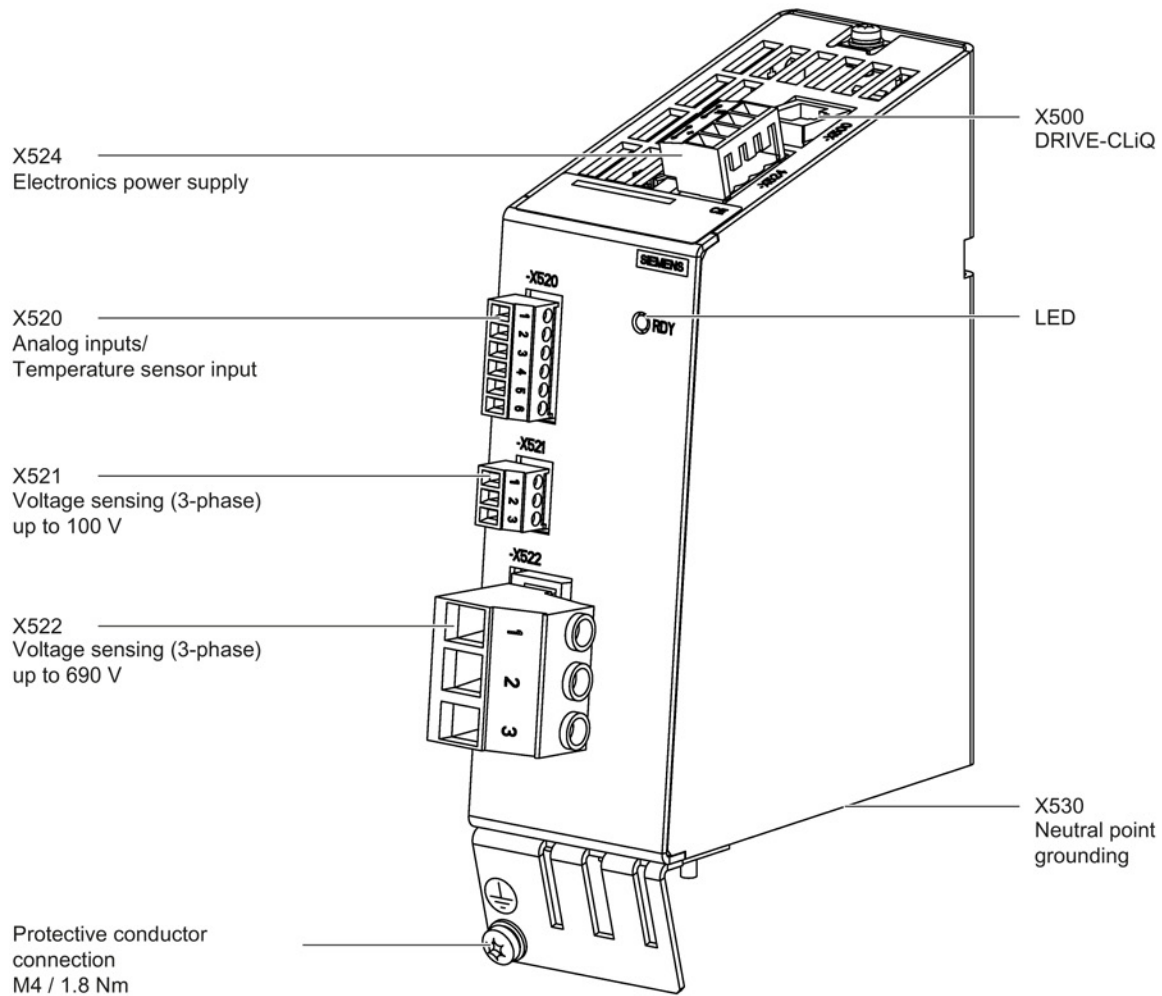

Figure 7-1 Interface overview of the VSM10

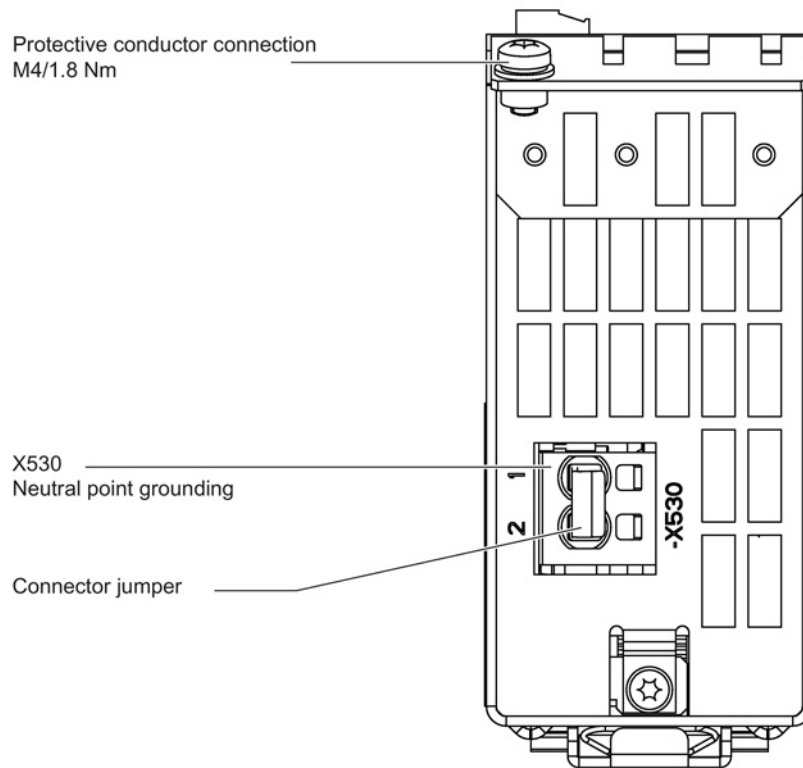
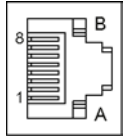

Figure 7-2 X530 interface at the VSM10 (view from below)

## 7.3.2 X500 DRIVE-CLiQ interface

Table 7- 2 X500: DRIVE-CLiQ interface

	Pin	Signal name	Technical data
	1	TXP	Transmit data +
	2	TXN	Transmit data -
	3	RXP	Receive data +
	4	Reserved, do not use	
	5	Reserved, do not use	
	6	RXN	Receive data -
	7	Reserved, do not use	
	8	Reserved, do not use	
	A	+ (24 V)	Power supply
	B	M (0 V)	Electronics ground
Connector type	DRIVE-CLiQ socket		

The blanking cover for the DRIVE-CLiQ port is included in the scope of delivery.

Blanking covers (50 x) Article No.: 6SL3066-4CA00-0AA0

### 7.3.3 X520 analog inputs/temperature sensor

Table 7- 3 X520: Analog inputs/temperature sensor

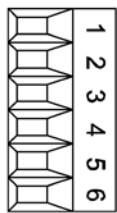
	Terminal	Designation	Technical data
	1	AI 0-	2 analog differential inputs <b>Voltage:</b> -10 ... +10 V; Ri > 100 kΩ <b>Resolution:</b> 12 bits + sign
	2	AI 0+	
	3	AI 1-	
	4	AI 1+	
	5	+ Temp	Temperature sensor KTY84-1C130/PTC
	6	- Temp	Measuring current via temperature sensor connection: 2 mA
Type: Screw terminal 1 (Page 336) Max. cross-section that can be connected: 1.5 mm <sup>2</sup>			

**Note****Permissible voltage values**

The common mode range must not be violated in order to avoid incorrect analog-digital conversion results. The following voltages are permissible:

- Input voltage:  $\pm 30$  V (destruction limit)
- Common mode voltage:  $\pm 10$  V with respect to ground potential (increased errors when exceeded)

**NOTICE****Damage to motor in the event of incorrectly connected KTY temperature sensor**

If a KTY temperature sensor is connected with incorrect polarity, it is not possible to detect when the motor overheats. Overheating can cause damage to the motor.

- Connect a KTY temperature sensor with the correct polarity.

**Note**

In order to minimize noise emission, shielded cables should be used.

**Note**

The maximum cable length for a shielded cable applied on both sides to the temperature sensor and to the analog inputs is 30 m.

**! WARNING****Danger to life due to electric shock in the event of voltage flashovers on the temperature sensor cable**

Voltage flashovers in the signal electronics can occur in motors without safe electrical separation of the temperature sensors.

- Only use temperature sensors that fully comply with the specifications of the safety isolation.
- If safe electrical separation cannot be guaranteed (for linear motors or third-party motors, for example), use a Sensor Module External (SME120 or SME125) or Terminal Module TM120.

### 7.3.4 X521 three-phase voltage sensing up to 100 V 3-ph. AC

Table 7- 4 X521: Voltage sensing 100 V

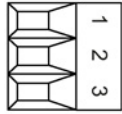
	Terminal	Designation	Technical data
	1	Phase voltage U	Connection to the voltage sensing for medium-voltage networks via a safe electrically isolated transformer Resistance to neutral point: ~500 kΩ Insulation resistance, neutral point - ground when the jumper is not inserted: >10 MΩ
	2	Phase voltage V	
	3	Phase voltage W	
Type: Screw terminal 1 (Page 336) Max. cross-section that can be connected: 1.5 mm <sup>2</sup>			

#### NOTICE

##### Damage to the VSM10 as a result of an impermissible terminal assignment

The VSM10 has two terminal strips, X521 and X522, to sense the three-phase line supply voltage. A terminal assignment which is not permissible results in the module being damaged.

- Use just one of the two terminal strips.
- Only connect voltages to terminal strip X521 up to a maximum 100 V (phase-to-phase) via a transformer.
- Only connect voltages to terminal strip X522 up to a maximum 690 V (phase-to-phase) directly.

### 7.3.5 X522 three-phase voltage sensing up to 690 V 3-ph. AC

Table 7- 5 X522: Voltage sensing 690 V

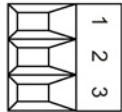
	Terminal	Designation	Technical data
	1	Phase voltage U	Directly connected to the line voltage sensing Resistance to neutral point: ~3500 kΩ Insulation resistance, neutral point - ground when the jumper is not inserted: >10 MΩ
	2	Phase voltage V	
	3	Phase voltage W	
Type: Screw terminal 5 (Page 336) Max. cross-section that can be connected: 6 mm <sup>2</sup>			

**NOTICE****Damage to the VSM10 as a result of an impermissible terminal assignment**

The VSM10 has two terminal strips, X521 and X522, to sense the three-phase line supply voltage. A terminal assignment which is not permissible results in the module being damaged.

- Use just one of the two terminal strips.
- Only connect voltages to terminal strip X521 up to a maximum 100 V (phase-to-phase) via a transformer.
- Only connect voltages to terminal strip X522 up to a maximum 690 V (phase-to-phase) directly.

**NOTICE****Damage to the VSM10 through overcurrent with an incorrect connection sequence**

Enabling the Line Module with an incorrect connection sequence results in overcurrent.

- Connect the line phases to the VSM10 in the same sequence as the one to the Line Module.

**Note****Line voltage tap**

If the configuration has a line filter, then the phase voltages for the VSM (X522) must be taken from in front of the line filter. If the configuration does not have a line filter, then X522 must be connected to the line side of the line reactor (voltages are taken from in front of the line reactor).

### 7.3.6 X524 Electronics power supply

Table 7- 6 X524: Electronics power supply

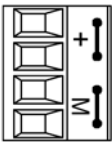
	Terminal	Designation	Technical data
	+	Electronics power supply	Voltage: 24 V DC (20.4 ... 28.8 V) Current consumption: max. 0.2 A
	+	Electronics power supply	
	M	Electronics ground	Max. current through the jumper in the connector: 20 A
	M	Electronics ground	
Type: Screw terminal 3 (Page 336)			

The maximum cable length that can be connected is 30 m.

**Note**

The two "+" or "M" terminals are jumpered in the connector. This ensures that the supply voltage is looped through.

**7.3.7 X530 neutral point grounding**

Table 7- 7 X530: Neutral point grounding

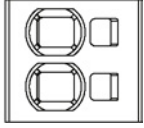
	Terminal	Designation	Technical data
	1	Neutral point of the voltage sensing	Jumper inserted: Grounded measurement
	2	Ground potential	Jumper not inserted: isolated measurement
Type: Spring-loaded terminal 5 (Page 336) Max. cross-section that can be connected: 10 mm <sup>2</sup>			

The Voltage Sensing Module is supplied with inserted jumper. When delivered, the neutral point is connected to the protective conductor via the connector jumper. A current flows to PE as a result of the voltage to be measured. This connection is removed by removing the connector jumper. The measurement is then electrically isolated.

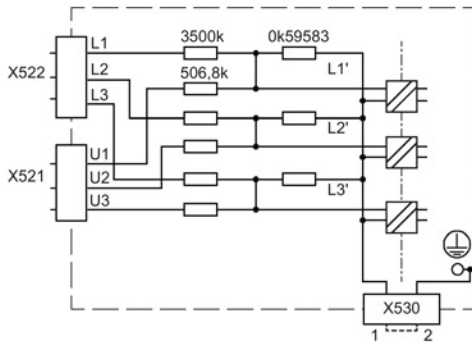
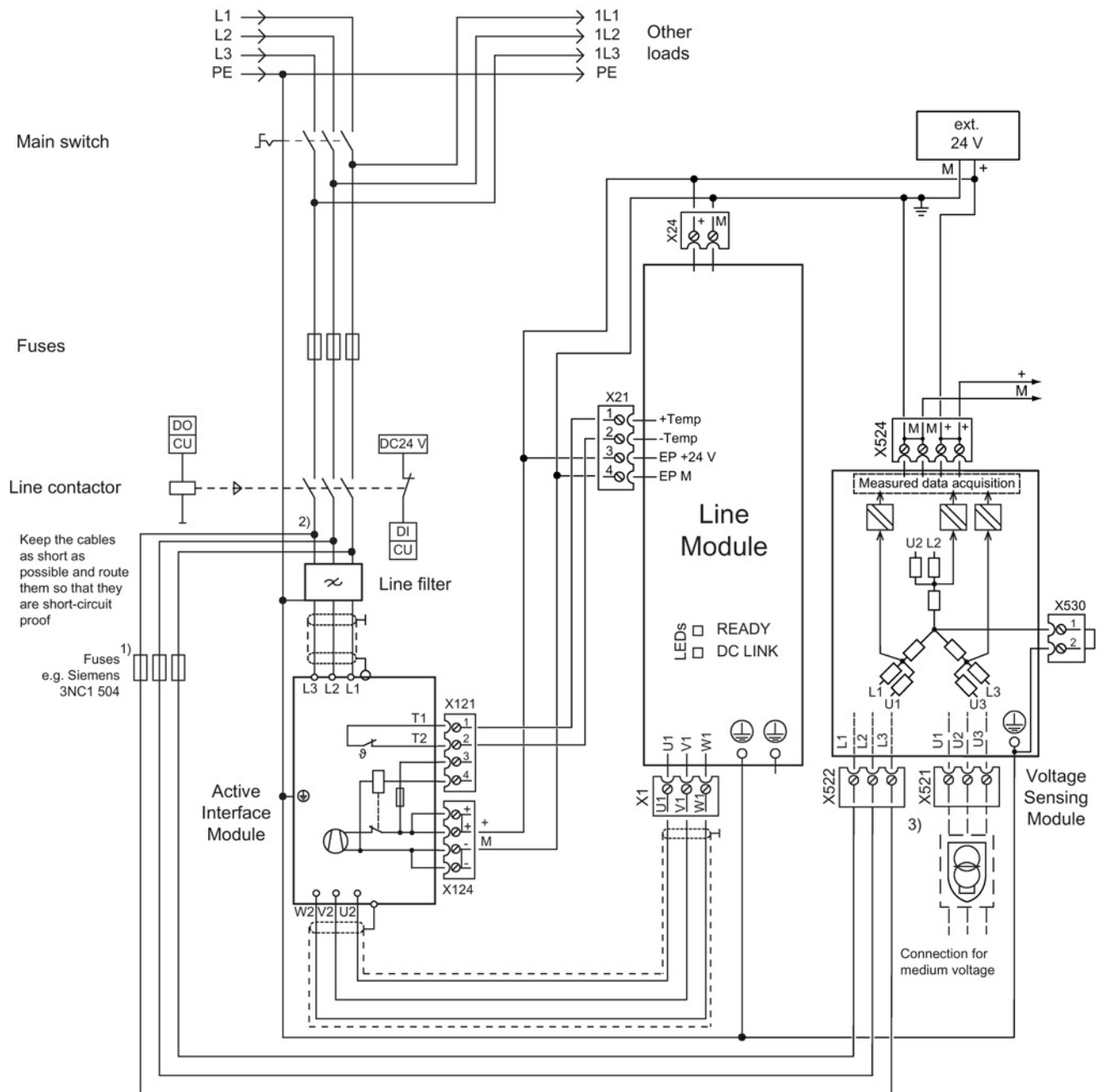

Figure 7-3 Internal circuit of the Voltage Sensing Module VSM10



## 7.4 Connection example



- 1) It is only possible to omit the fuses if the cables to the Voltage Sensing Module are routed so that no short-circuit or ground fault can be expected under normal operating conditions (short-circuit proof routing).
- 2) Tap the line voltage as actual value for the Voltage Sensing Module VSM10 corresponding to the system design, for example refer to the table.
- 3) Only one of the two terminals X521 and X522 may be used at one time!

Figure 7-4 Connection example for the VSM10 to measure the line voltage

7.4 Connection example

Table 7- 8 Suggestions for terminals and cable lugs which can be used to connect a VSM10 to the line

Conductor cross-section	Connection via	For components
Up to 6 mm <sup>2</sup>	Direct connection possible	Smart Line Modules 5 kW and 10 kW
6 mm <sup>2</sup> to 16 mm <sup>2</sup>	ST16-TWIN terminal blocks, if required with a reducing jumper and ST4-TWIN or ST2.5-TWIN (Phoenix Contact company)	Active Line Modules 16 kW Smart Line Modules 16 kW Active Interface Module 16 kW
16 mm <sup>2</sup> to 50 mm <sup>2</sup>	AGK10 UKH tap-off terminals with UKH terminals (Phoenix Contact company)	Active Line Modules 36 kW and 55 kW Smart Line Modules 36 kW and 55 kW Active Interface Module 36 kW and 55 kW
> 50 mm <sup>2</sup>	Ring cable lug without insulation (Page 338) 8 mm/2.5 mm <sup>2</sup>	Components with M8 connection bolts Active Line Modules 55 kW, 80 kW, and 120 kW Active Interface Module 80 kW and 120 kW
	Intermediate high-current connector, type UHV (Phoenix Contact) and ring cable lug without insulation (Page 338) 8 mm/2.5 mm <sup>2</sup>	

## 7.5 Meaning of the LED

Table 7- 9 Meanings of the LEDs on the Voltage Sensing Module VSM10

LED	Color	Status	Description, cause	Remedy	
READY	–	Off	The electronics power supply is missing or outside the permissible tolerance range.	–	
	Green	Continuous light	The component is ready for operation. Cyclic DRIVE-CLiQ communication is taking place.	–	
	Orange	Continuous light	DRIVE-CLiQ communication is being established.	–	
	Red	Continuous light	This component has at least one fault. <b>Note:</b> LED is controlled irrespective of the corresponding messages being reconfigured.	Remove and acknowledge the fault.	
	Green/red	Flashing light 0.5 Hz	Flashing light 0.5 Hz	Firmware is being downloaded.	–
			Flashing light 2 Hz	Firmware download is complete. The system waits for POWER ON.	Carry out a POWER ON.
	Green/orange or Red/orange	Flashing light	Component recognition via LED is activated <sup>1)</sup> . <b>Note:</b> Both options depend on the LED status when component recognition is activated.	–	

<sup>1)</sup> The parameters for activating component recognition using LEDs can be taken from the following reference:  
Reference: /LH1/ SINAMICS S120/S150 List Manual

### Cause and rectification of faults

Additional information about the cause and resolving faults can be taken from the following references:

- Reference: /LH1/SINAMICS S120/S150 List Manual
- Reference: /IH1/ SINAMICS S120 Commissioning Manual

### 7.6 Dimension drawing

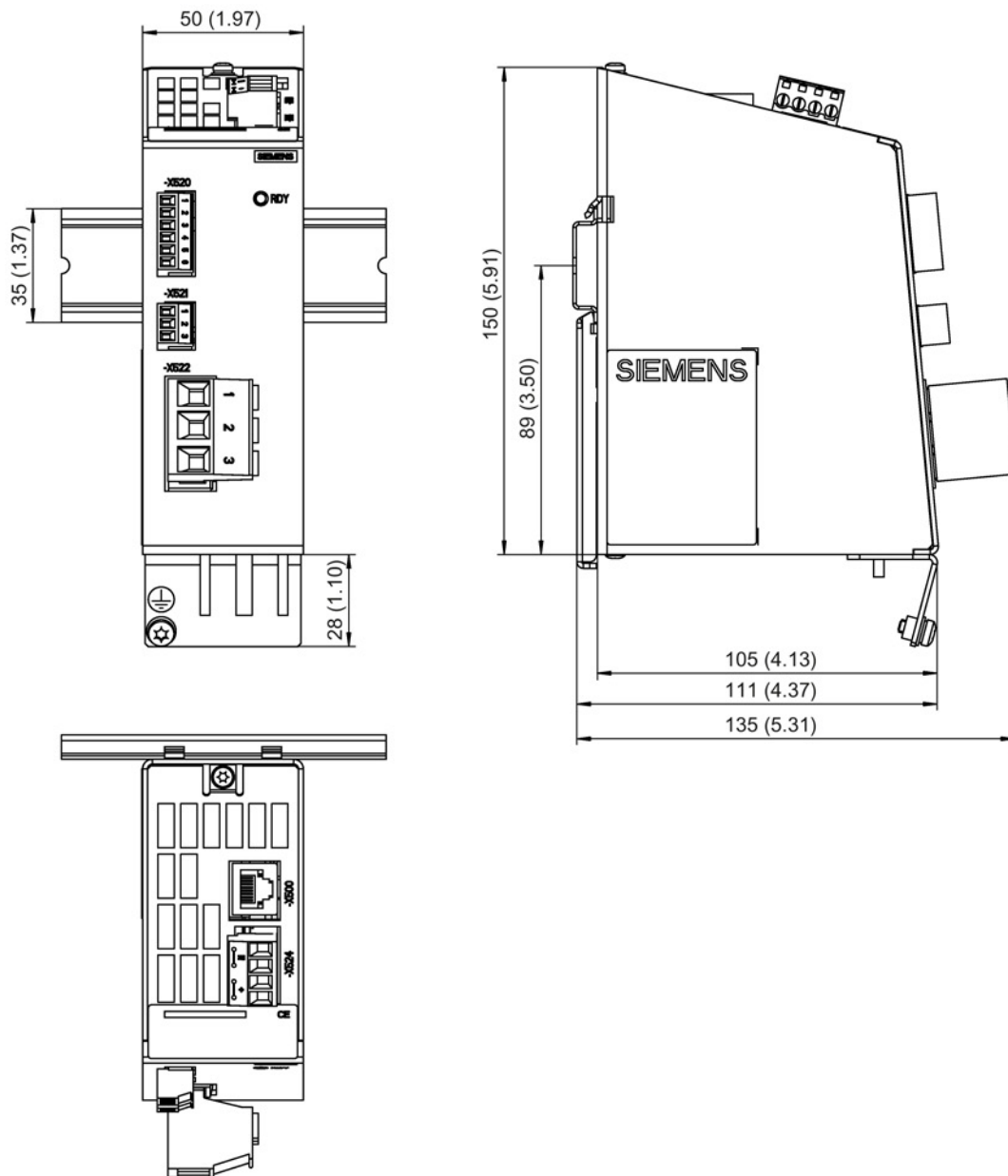

Figure 7-5 Dimension drawing of the Voltage Sensing Module VSM10, all data in mm and (inches)

## 7.7 Installation

### Installation

1. Tilt the component backwards slightly and attach it to the DIN rail using the hooks.
2. Swivel the component onto the DIN rail until you hear the mounting slide at the rear latch into position.
3. Slide the component along the mounting rail to either the left or the right into its final position.

### Removal

1. First shift the mounting slide downwards at the lug to release the interlocking with the mounting rail.
2. Swivel the component to the front and withdraw it upwards from the DIN rail.

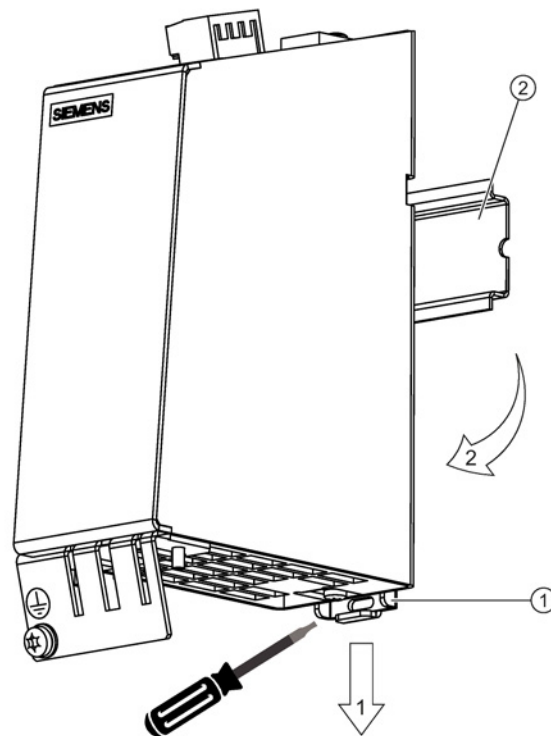

- ① Mounting slide  
② Mounting rail

Figure 7-6 Removing from a DIN mounting rail

## 7.8 Protective conductor connection and shield support

The following shield connection clamps can be used on the bottom part of the component housing for shield connection of the analog inputs:

Shield connection clamp		Article No.
Phoenix Contact	SK8	3025163
Phoenix Contact	SK14	3025176
Phoenix Contact	SK20	3025189
Weidmüller	KLBÜ CO1	1753311001

The following pictures show the shield contacts with a shield connection clamp from Weidmüller.

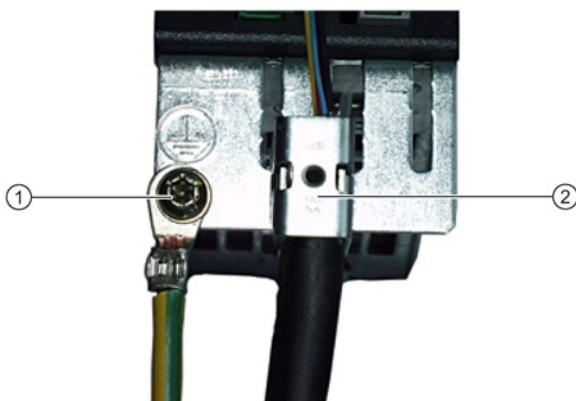

- ① Protective conductor connection M4 / 1.8 Nm
- ② Shield connection terminal, Weidmüller, type: KLBÜ CO1, Article No.: 1753311001

Figure 7-7 Shield support and protective conductor connection at the VSM10

### NOTICE

#### Damage or faulty operation due to incorrect shielding or inadmissible cable lengths

If the correct shielding procedures or the permissible cable lengths are not observed, it can cause damage or the machine may malfunction.

- Only use shielded cables.
- Do not exceed the cable lengths stated in the technical data.

## 7.9 Operation on an isolated-neutral system (IT system)

When using a Voltage Sensing Module on an insulated line supply (IT supply system), remove the connector jumper in terminal X530 at the lower side of the component.

Use two screwdrivers or a suitable tool in order to relieve the holding springs in the terminal and then withdraw the connector jumper.

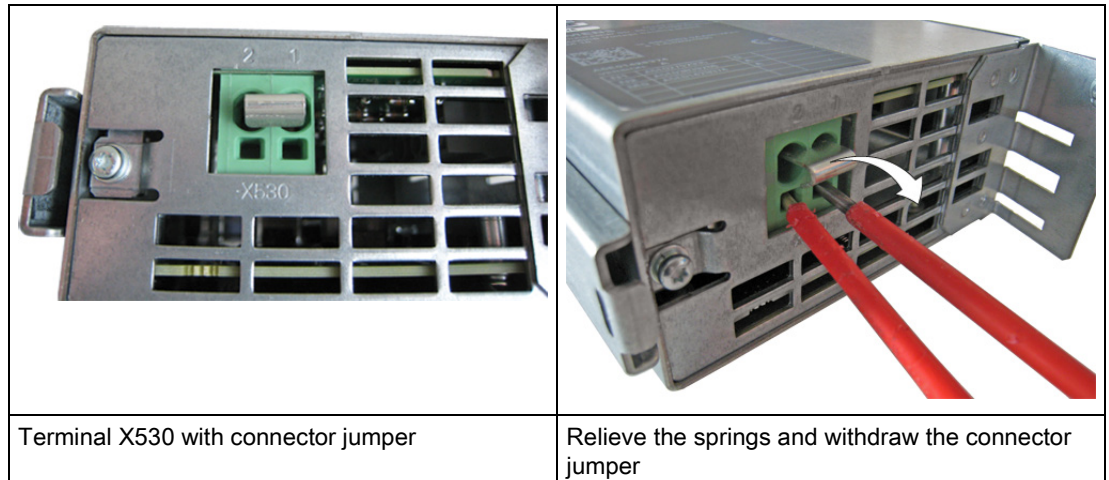

## 7.10 Technical data

Table 7- 10 Technical data

6SL3053-0AA00-3AA1	Unit	Value
Electronics power supply		
Voltage	V <sub>DC</sub>	24 (20.4 ... 28.8)
Current (without DRIVE-CLiQ)	A <sub>DC</sub>	0.3
Maximum cable length	m	30
Power loss	W	< 10
PE/ground connection	At the housing with M4/1.8 Nm screw	
Weight	kg	1
Degree of protection		IP20

## 7.11 Service and maintenance

### Replacing the Voltage Sensing Module VSM10 in Smart Line Modules Chassis and Active Interface Modules Chassis

When using a Voltage Sensing Module VSM10 in an Active Interface Module Chassis or Smart Line Module Chassis, it is essential that you observe the following application cases:

1. Replacing a VSM10 with article number 6SL3053-0AA00-3AA0 by a VSM10 with article number 6SL3053-0AA00-3AA1:

It is NOT permissible that the connector jumper ① at terminal X530 at the lower side of the VSM10 is removed!

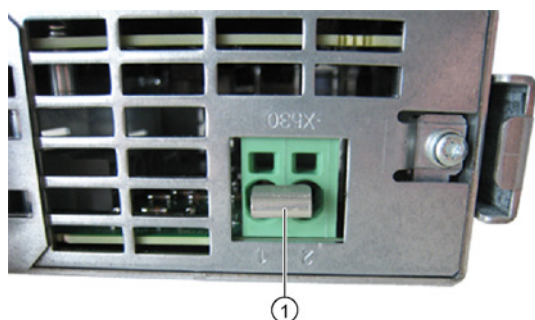

2. Replacing a VSM10 with article number 6SL3053-0AA00-3AA1 by a VSM10 with article number 6SL3053-0AA00-3AA1:

Proceed with the connector jumper ① at terminal X530 of the new VSM10 (spare part) just the same as at the previously installed VSM10.



**! DANGER**

**Danger to life due to electric shock when incorrectly replacing spare parts**

If you remove the connector jumper at terminal X530 when replacing a VSM10 with article number 6SL3053-0AA00-3AA0 by a VSM10 with article number 6SL3053-0AA00-3AA1, then a hazardous voltage is present in the Active Interface Module Chassis or Smart Line Module Chassis. Death or serious injury can result when live parts are touched.

- When replacing the VSM10 proceed as specified above.



# Encoder system connection

## 8.1 Introduction

The encoder system should be connected to SINAMICS S120 via DRIVE-CLiQ.

Motors with DRIVE-CLiQ interfaces (e.g. synchronous motors 1FK7 and 1FT7, and induction motors 1PH7 and 1PH8) are designed for this purpose. These motors simplify commissioning and diagnostics because the motor and encoder type are identified automatically.

### Motors and external encoders without DRIVE-CLiQ interface

Motors without DRIVE-CLiQ interfaces, as well as external encoders without integrated DRIVE-CLiQ interface, must be connected via Sensor Modules to enable the encoder and temperature signals to be evaluated. Sensor Modules Cabinet-Mounted (SMC) are available for installation in control cabinets and Sensor Modules External (SME) for installation outside control cabinets.

If not otherwise specified, only one encoder system can be connected to each Sensor Module.

### Motors and external encoders with DRIVE-CLiQ interface

Motors with DRIVE-CLiQ interfaces can be connected to the associated Motor Module directly via the MOTION-CONNECT DRIVE-CLiQ cables available. The connection of the MOTION-CONNECT DRIVE-CLiQ cable at the motor has degree of protection IP67.

The DRIVE-CLiQ interface supplies the motor encoder via the integrated 24 V DC supply and transfers the motor encoder and temperature signals and the electronic rating plate data, such as a unique identification number, rated data (voltage, current, torque) directly to the Control Unit. Different encoder cables are therefore no longer required for the various encoder types, e.g. resolvers or absolute encoders. Wiring can be effected throughout with a MOTION-CONNECT DRIVE-CLiQ cable.

### DRIVE-CLiQ encoder

A DRIVE-CLiQ encoder is an absolute encoder with integrated DRIVE-CLiQ interface (see Chapter DRIVE-CLiQ encoder (Page 317)).

## 8.2 Overview of Sensor Modules

### Sensor Modules Cabinet-Mounted (SMC)

Sensor Modules Cabinet-Mounted SMC10, SMC20, SMC30 and SMC40 can be ordered and configured separately. They are used when a motor with a DRIVE-CLiQ interface is not available or when external encoders in addition to the motor encoder are required. Only one encoder system may be connected to the Sensor Modules Cabinet-Mounted SMC10, SMC20 and SMC30. The SMC40 supports two encoder systems. The Sensor Modules Cabinet-Mounted evaluate these measuring systems and convert the calculated values to DRIVE-CLiQ. Motor or encoder data are not saved.

---

#### Note

The Sensor Module Cabinet-Mounted supplies the power to the encoder; however, the Sensor Module Cabinet-Mounted must be provided separately with 24 V DC.

---

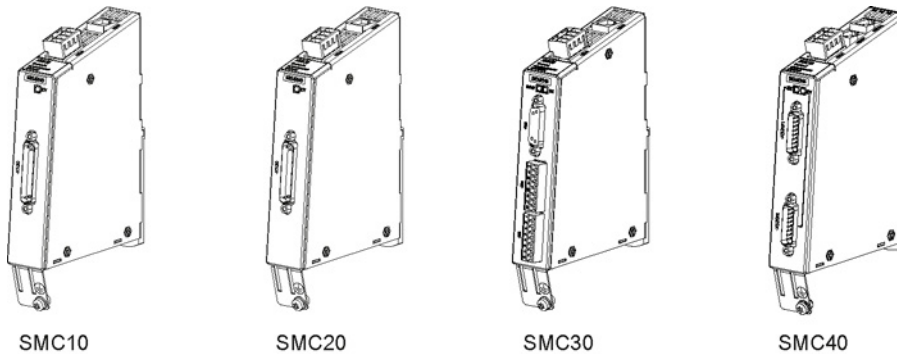

Figure 8-1 Overview of Sensor Modules Cabinet-Mounted (SMC)

### Sensor Modules External (SME)

The Sensor Modules External SME20, SME25, SME120, and SME125 are only intended for use on machines (in North America, in accordance with the NFPA 79 "Electrical Standard for Industrial Machinery"). It is not permissible to connect DRIVE-CLiQ interfaces to other networks, e.g. Ethernet, but only to the DRIVE-CLiQ interfaces of the components.

Direct encoder systems outside the cabinet can be connected to the Sensor Modules External. The Sensor Modules External evaluate these encoder systems and convert the calculated values to DRIVE-CLiQ. No motor or encoder data is stored in the Sensor Modules External.

---

#### Note

The Sensor Module External provides the encoder power supply. The power supply for the Sensor Module External is provided from the connected DRIVE-CLiQ cable. This fact must be taken into consideration when the DRIVE-CLiQ cable is selected.

---

The Sensor Modules External have a higher degree of protection (IP67) and are therefore suitable for installation outside the cabinet.

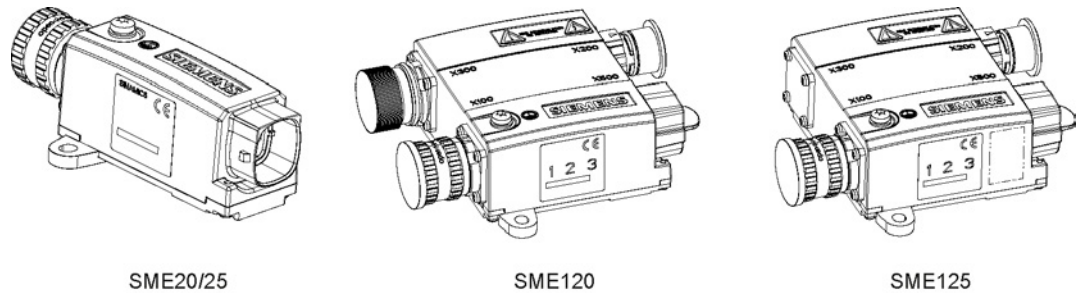

Figure 8-2 Overview of Sensor Modules External (SME)

### Connectable encoder systems

Table 8- 1 Overview of the connectable encoder systems

Encoder systems	SMC				SME			
	SMC10	SMC20	SMC30	SMC40	SME20	SME25	SME120	SME125
Resolver	Yes	-	-	-	-	-	-	-
Incremental encoder sin/cos (1 Vpp) with/without reference signal	-	Yes	-	-	Yes	-	Yes	-
Incremental encoder TTL / HTL	-	-	Yes	-	-	-	-	-
Absolute encoder EnDat 2.1 <sup>1)</sup>	-	Yes	-	-	-	Yes	-	Yes
Absolute encoder EnDat 2.2 <sup>2)</sup>	-	-	-	Yes	-	-	-	-
Absolute encoder SSI	-	Yes <sup>3)</sup>	Yes <sup>4)</sup>	-	-	Yes <sup>3)</sup>	-	Yes <sup>3)</sup>
Temperature evaluation	Yes	Yes	Yes	-	Yes <sup>5)</sup>	-	Yes (protective electrical separation)	Yes (protective electrical separation)

1) Absolute encoders EnDat 2.2 with Article No. 02 can also be connected

2) Absolute encoders EnDat 2.2 with Article No. 22 can be connected, absolute encoders EnDat 2.2 with Article No. 02 cannot be connected

3) Only possible for SSI encoders with 5 V supply

4) Possible for SSI encoders with 5 V or 24 V supply

5) With specified 6FX8002-2CA88 adapter cable

### 8.3 Safety instructions for Sensor Modules and encoders

 <b>WARNING</b>
<b>Danger to life if the fundamental safety instructions and remaining risks are not carefully observed</b>
If the fundamental safety instructions and remaining risks in Chapter 1 (Page 19) are not observed, accidents involving severe injuries or death may occur.
<ul style="list-style-type: none"><li>• Adhere to the fundamental safety instructions.</li><li>• When assessing the risk, take into account remaining risks.</li></ul>

 <b>WARNING</b>
<b>Danger to life due to fire if overheating occurs because of insufficient ventilation clearances</b>
Inadequate ventilation clearances can cause overheating of components with subsequent fire and smoke. This can cause severe injury or even death. This can also result in increased downtime and reduced service lives for devices/systems.
<ul style="list-style-type: none"><li>• For this reason, it is imperative that you maintain the 50 mm clearances above and below the Sensor Module Cabinet-Mounted.</li></ul>

**Note**

**Risk of encoder failures by encoder signal disturbances**

Unfavorable material combinations generate static electricity between the belt pulley and the belt. This electrostatic charge (several kV) can discharge via the motor shaft and the encoder which leads to disturbance of the encoder signals (encoder error).

- Use an antistatic version of the belt (special conductive polyurethane mixture).



 <b>WARNING</b>
<b>Danger to life due to electric shock when disconnecting and connecting encoder cables during operation</b>
When opening plug connections in operation, arcs can result in severe injury or death.
<ul style="list-style-type: none"><li>• Only disconnect or connect the encoder cables to Siemens motors in a voltage-free state if hot-plugging has not been specifically released. When using direct measuring systems (third-party encoders), ask the manufacturer whether it is permissible to disconnect/connect under voltage.</li></ul>

**NOTICE****Damage when connecting an impermissible number of encoder systems**

If more than the maximum permissible number of encoder systems are connected to a Sensor Module, this will cause damage.

- At a Sensor Module only connect the maximum permissible number of encoder systems.
  - Sensor Modules SMC10, SMC20 and SMC30: Single-encoder system
  - Sensor Module SMC40: Two-encoder systems
  - Sensor Modules SME<sub>x</sub>: Single-encoder system

**Note****Diminished level of interference immunity due to equalizing currents via the electronics ground**

Ensure that there are no electrical connections between the encoder system housing and the signal cables, or the encoder system electronics.

If this is not carefully observed, under certain circumstances the system will not be able to reach the required interference immunity level (there is then a danger of equalization currents flowing through the electronics ground).

**NOTICE****Damage through use of incorrect DRIVE-CLiQ cables**

Damage or malfunctions can occur on the devices or system when incorrect or unreleased DRIVE-CLiQ cables are used.

- Only use suitable DRIVE-CLiQ cables that have been released by Siemens for the respective application.

**Note****Function equipotential bonding for distributed DRIVE-CLiQ nodes**

Integrate all of the components that are connected via DRIVE-CLiQ in the functional equipotential bonding concept. The connection should be preferably established by mounting on metallic bare machine and plant components that are connected with one another using an equipotential bonding conductor.

Alternatively, you can establish equipotential bonding using a conductor (min. 6 mm<sup>2</sup>), which as far as possible, is routed in parallel to the DRIVE-CLiQ cable. All distributed DRIVE-CLiQ nodes are involved, for example DMx20, SME2<sub>x</sub>, SM12<sub>x</sub> etc.

**Note****Malfunctions due to polluted DRIVE-CLiQ interfaces**

Malfunctions can occur in the system through the use of polluted DRIVE-CLiQ interfaces.

- Cover unused DRIVE-CLiQ interfaces with the supplied blanking covers.

## **8.4 Sensor Module Cabinet-Mounted SMC10**

### **8.4.1 Description**

The Sensor Module Cabinet-Mounted SMC10 is an expansion module for snapping on to a standard mounting rail acc. to EN 60715. It evaluates encoder signals and transmits the speed, actual position value, rotor position and, if necessary, the motor temperature via DRIVE-CLiQ to the Control Unit.

The SMC10 is used to evaluate sensor signals from resolvers.

## 8.4.2 Interface description

### 8.4.2.1 Overview

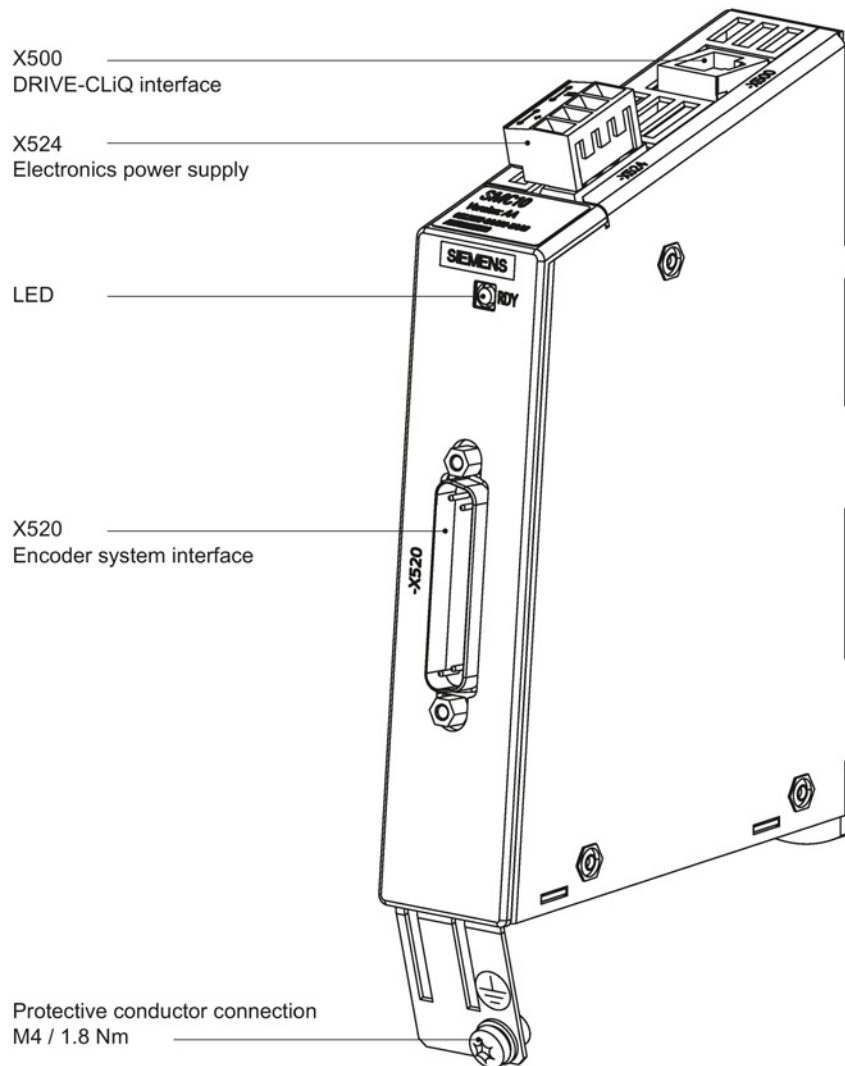
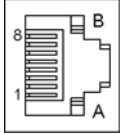

Figure 8-3 Interface overview for the SMC10

8.4.2.2 X500 DRIVE-CLiQ interface

Table 8- 2 X500: DRIVE-CLiQ interface

	Pin	Signal name	Technical data
	1	TXP	Transmit data +
	2	TXN	Transmit data -
	3	RXP	Receive data +
	4	Reserved, do not use	
	5	Reserved, do not use	
	6	RXN	Receive data -
	7	Reserved, do not use	
	8	Reserved, do not use	
	A	Reserved, do not use	
	B	M (0 V)	Electronics ground
	Connector type	DRIVE-CLiQ socket	

The blanking cover for the DRIVE-CLiQ port is included in the scope of delivery.

Blanking covers (50 x) Article No.: 6SL3066-4CA00-0AA0



### 8.4.2.3 X520 encoder system interface

Table 8- 3 X520: Encoder system interface

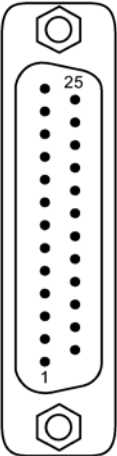
	Pin	Signal name	Technical data
	1	Reserved, do not use	
	2	Reserved, do not use	
	3	S2	Resolver signal A (sin+)
	4	S4	Inverted resolver signal A (sin-)
	5	Ground	Ground (for internal shield)
	6	S1	Resolver signal B (cos+)
	7	S3	Inverted resolver signal B (cos-)
	8	Ground	Ground (for internal shield)
	9	R1	Resolver excitation positive
	10	Reserved, do not use	
	11	R2	Resolver excitation negative
	12	Reserved, do not use	
	13	+ Temp <sup>1)</sup>	Motor temperature sensing KTY84-1C130 (KTY+) Temperature sensor KTY84-1C130 / PTC
	14	Reserved, do not use	
	15	Reserved, do not use	
	16	Reserved, do not use	
	17	Reserved, do not use	
	18	Reserved, do not use	
	19	Reserved, do not use	
	20	Reserved, do not use	
	21	Reserved, do not use	
	22	Reserved, do not use	
	23	Reserved, do not use	
	24	Ground	Ground (for internal shield)
	25	- Temp <sup>1)</sup>	Motor temperature sensing KTY84-1C130 (KTY-) Temperature sensor KTY84-1C130 / PTC
Connector type:	25-pin SUB D connector		
Measuring current via temperature sensor connection: 2 mA			

1) Accuracy of temperature measurement:  
 - KTY:  $\pm 7$  °C (incl. evaluation)  
 - PTC:  $\pm 5$  °C (incl. evaluation)

**NOTICE**

**Damage to motor due to incorrectly connected KTY temperature sensor**

If a KTY temperature sensor is connected with incorrect polarity, it is not possible to detect when the motor overheats. Overheating can cause damage to the motor.

- Connect a KTY temperature sensor with the correct polarity.



**WARNING**

**Danger to life due to electric shock in the event of voltage flashovers at the temperature sensor**

Voltage flashovers in the signal electronics can occur in motors without safe electrical separation of the temperature sensors.

- Use temperature sensors that comply with the specifications regarding safe electrical separation.
- If safe electrical separation cannot be guaranteed (for linear motors or third-party motors, for example), use a Sensor Module External (SME120 or SME125) or Terminal Module TM120.

**8.4.2.4 X524 Electronics power supply**

Table 8- 4 X524: Electronics power supply

	Terminal	Function	Technical data
	+	Electronics power supply	Voltage: 24 V (20.4 ... 28.8 V) Current consumption: max. 0.35 A Max. current through the jumper in the connector: 20 A (15 A according to UL/CSA)
	+	Electronics power supply	
	M	Electronics ground	
	M	Electronics ground	
Type: Screw terminal 2 (Page 336)			

The maximum cable length that can be connected is 30 m.

**Note**

The two "+" or "M" terminals are jumpered in the connector. This ensures that the supply voltage is looped through.

### 8.4.3 Connection example

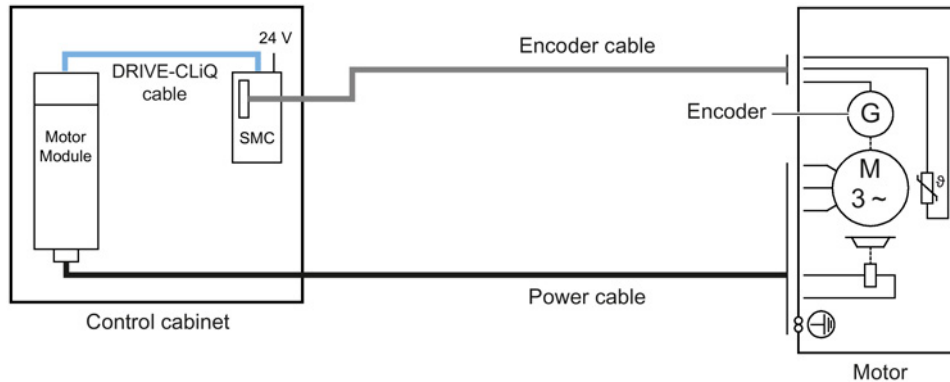

Figure 8-4 Connection of an encoder system via a Sensor Module Cabinet-Mounted (SMC) for a motor without a DRIVE-CLiQ interface

### 8.4.4 Meaning of the LED

Table 8- 5 Meaning of the LEDs on the Sensor Module Cabinet-Mounted SMC10

LED	Color	Status	Description, cause	Remedy
RDY READY	-	Off	The electronics power supply is missing or outside the permissible tolerance range.	-
	Green	Continuous light	The component is ready for operation. Cyclic DRIVE-CLiQ communication is taking place.	-
	Orange	Continuous light	DRIVE-CLiQ communication is being established.	-
	Red	Continuous light	This component has at least one fault. <b>Note:</b> The LED is activated irrespective of whether the corresponding messages have been reconfigured.	Remove and acknowledge the fault.
	Green/red	Flashing light 0.5 Hz	Firmware is being downloaded.	-
		Flashing light 2 Hz	Firmware download is complete. The system waits for POWER ON.	Carry out a POWER ON.
	Green/orange or Red/orange	Flashing light	Component recognition via LED is activated <sup>1)</sup> . <b>Note:</b> Both options depend on the LED status when component recognition is activated.	-

<sup>1)</sup> The parameters for activating component recognition using LEDs can be taken from the following reference:  
Reference: /LH1/ SINAMICS S120/S150 List Manual

### Cause and rectification of faults

Additional information about the cause and resolving faults can be taken from the following references:

- Reference: /LH1/SINAMICS S120/S150 List Manual
- Reference: /IH1/ SINAMICS S120 Commissioning Manual

### 8.4.5 Dimension drawing

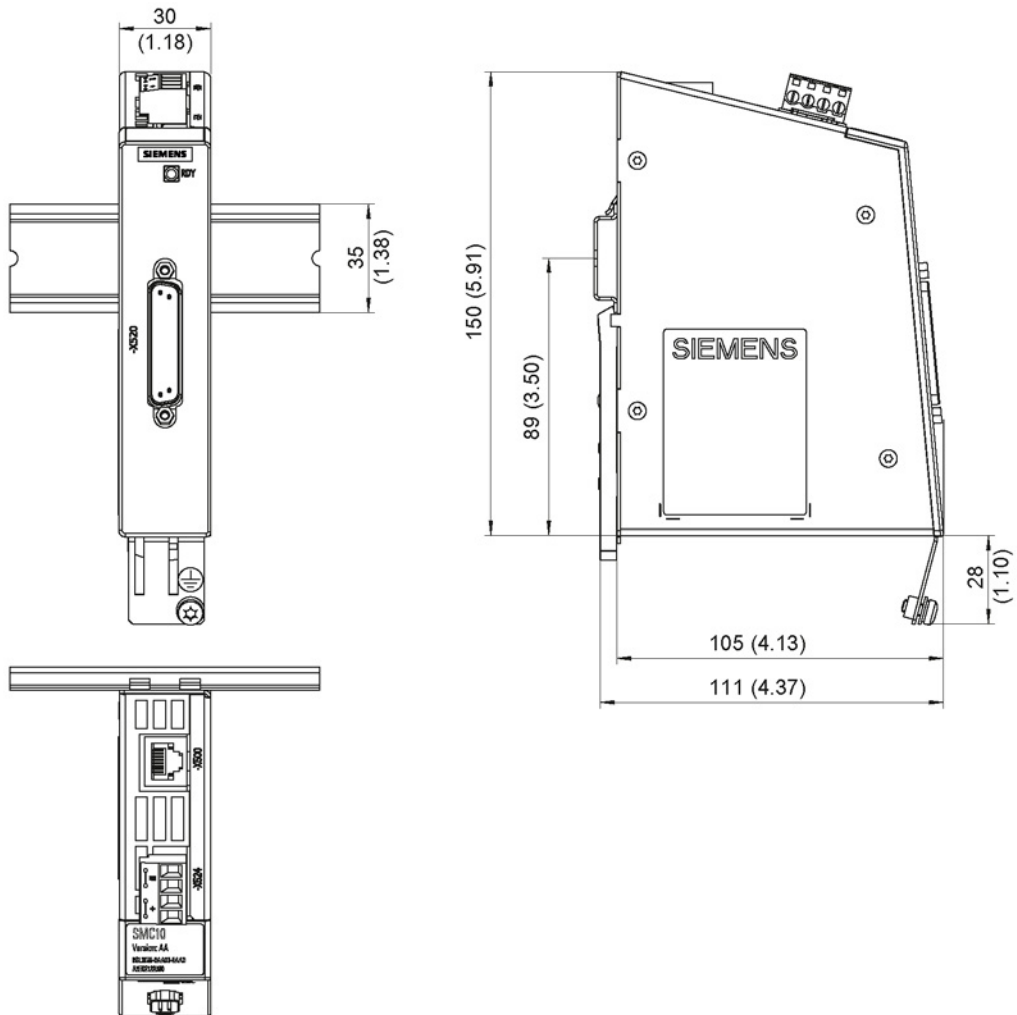

Figure 8-5 Dimension drawing of the Sensor Module Cabinet SMC10, all dimensions in mm and (inches)

## 8.4.6 Mounting

### Installation

1. Tilt the component backwards slightly and attach it to the DIN rail using the hooks.
2. Swivel the component onto the DIN rail until you hear the mounting slide at the rear latch into position.
3. Slide the components along the mounting rail to either the left or right up to their final position.

### Removal

1. First shift the mounting slide downwards at the lug to release the interlocking with the mounting rail.
2. Swivel the component to the front and withdraw it upwards from the DIN rail.

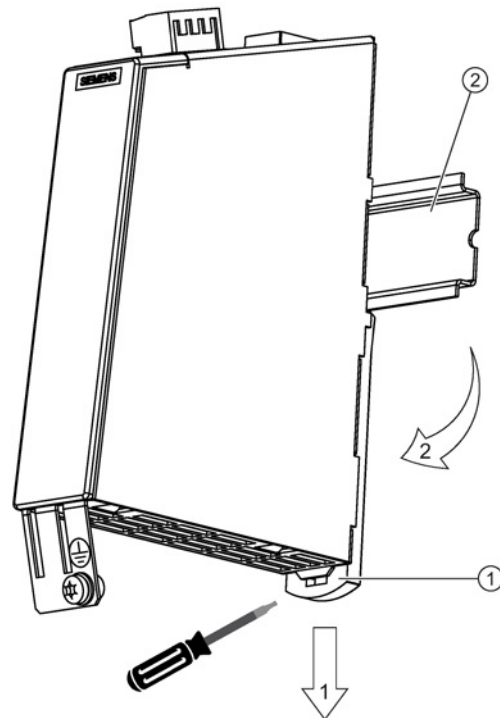

- ① Mounting slide
- ② Mounting rail

Figure 8-6 Removing from a DIN mounting rail

## 8.4.7 Technical data

Table 8- 6 Technical data

6SL3055-0AA00-5AAx	Unit	Value
<b>Electronics power supply</b>		
Voltage	V <sub>DC</sub>	24 (20.4 ... 28.8)
Current (without encoder system)	A <sub>DC</sub>	≤ 0.20
Current (with encoder system)	A <sub>DC</sub>	≤ 0.35
Power loss	W	≤ 10
Max. Cable length	m	30
<b>Specification</b>		
Transformation ratio of the resolver (ü)		0.5
Excitation voltage on the SMC10 when ü=0.5	V <sub>rms</sub>	4.1
Amplitude monitoring threshold (secondary tracks) of the SMC10	V <sub>rms</sub>	1
Excitation voltage (cannot be parameterized)	V <sub>rms</sub>	4.1
Excitation frequency (synchronized to the current controller clock cycle)	kHz	5 to 16
PE/ground connection	At the housing with M4/1.8 Nm screw	
Max. Encoder cable length	m	130
Weight	kg	0.45
Degree of protection		IP20 or IPXXB

Table 8- 7 Max. frequency that can be evaluated (speed)

Resolver		Max. Speed, resolver/motor		
Number of poles	Number of pole pairs	8 kHz / 125 µs	4 kHz / 250 µs	2 kHz / 500 µs
2-pole	1	120000 rpm	60000 rpm	30000 rpm
4-pole	2	60000 rpm	30000 rpm	15000 rpm
6-pole	3	40000 rpm	20000 rpm	10000 rpm
8-pole	4	30000 rpm	15000 rpm	7500 rpm

The ratio between the ohmic resistance R and the inductance L (the primary winding of the resolver) determines whether the resolver can be evaluated with the SMC10. See the following diagram:

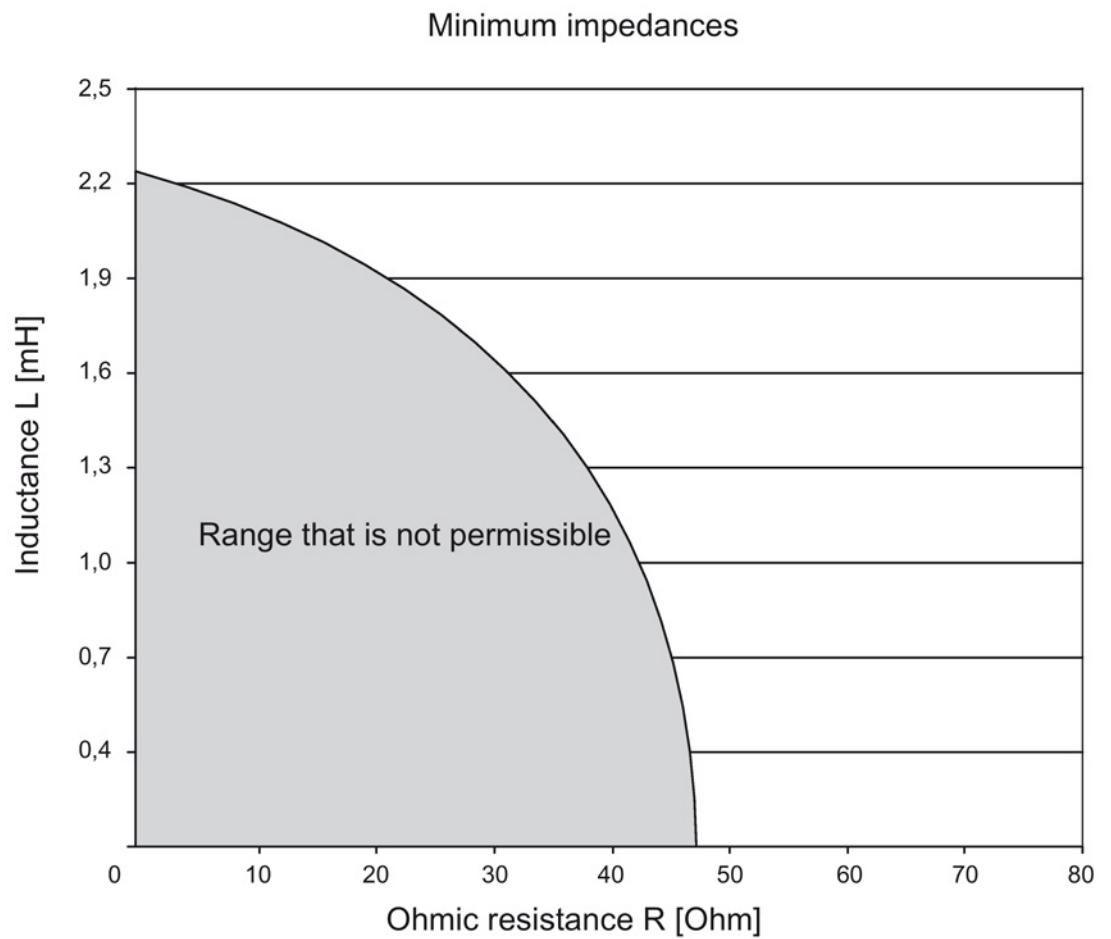

Figure 8-7 Rotor impedances that can be connected with excitation frequency  $f = 5000$  Hz

To check as shown in the figure above, the impedances  $Z_{rs}$  or  $Z_{ro}$  (impedance between R1 and R2 with short-circuited or open outputs) from the encoder manufacturer's data sheet must be used.

## **8.5 Sensor Module Cabinet-Mounted SMC20**

### **8.5.1 Description**

The Sensor Module Cabinet-Mounted SMC20 is an expansion module for snapping on to a standard mounting rail acc. to EN 60715. It evaluates encoder signals and transmits the speed, actual position, rotor position and, if applicable, the motor temperature and reference point via DRIVE-CLiQ to the Control Unit.

The SMC20 is used to evaluate encoder signals from incremental encoders with SIN/COS (1 Vpp) or absolute encoders with EnDat 2.1. EnDat 2.2 order designation 02 or SSI.



## 8.5.2 Interface description

### 8.5.2.1 Overview

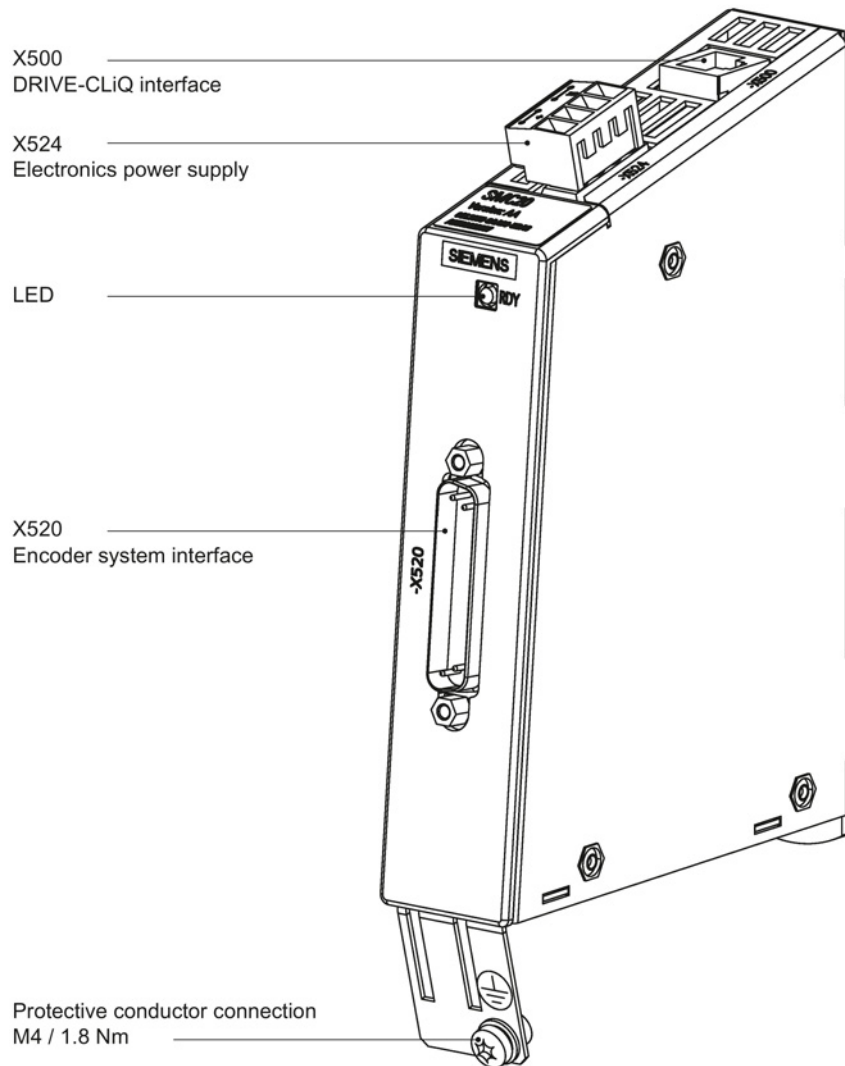
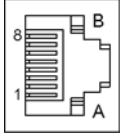

Figure 8-8 Interface description of the SMC20

## 8.5.2.2 X500 DRIVE-CLiQ interface

Table 8- 8 X500: DRIVE-CLiQ interface

	Pin	Signal name	Technical data
	1	TXP	Transmit data +
	2	TXN	Transmit data -
	3	RXP	Receive data +
	4	Reserved, do not use	
	5	Reserved, do not use	
	6	RXN	Receive data -
	7	Reserved, do not use	
	8	Reserved, do not use	
	A	Reserved, do not use	
	B	M (0 V)	Electronics ground
	Connector type	DRIVE-CLiQ socket	

The blanking cover for the DRIVE-CLiQ port is included in the scope of delivery.

Blanking covers (50 x) Article No.: 6SL3066-4CA00-0AA0

### 8.5.2.3 X520 encoder system interface

Table 8- 9 X520: Encoder system interface

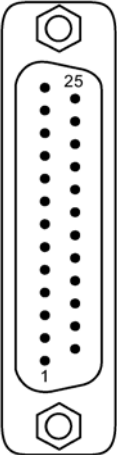
	Pin	Signal name	Technical data
	1	P encoder	Encoder power supply
	2	M encoder	Ground for encoder power supply
	3	A	Incremental signal A
	4	A*	Inverse incremental signal A
	5	Ground	Ground (for internal shield)
	6	B	Incremental signal B
	7	B*	Inverse incremental signal B
	8	Ground	Ground (for internal shield)
	9	Reserved, do not use	
	10	Clock	Clock, EnDat interface, SSI clock
	11	Reserved, do not use	
	12	Clock*	Inverted clock, EnDat interface, inverted SSI clock
	13	+Temp <sup>1)</sup>	Motor temperature sensing KTY84-1C130 (KTY+) Temperature sensor KTY84-1C130 / PTC
	14	P sense	Sense input of encoder power supply
	15	Data	Data, EnDat interface, SSI data
	16	M sense	Ground sense input encoder power supply
	17	R	Reference signal R
	18	R*	Inverse reference signal R
	19	C	Absolute track signal C
	20	C*	Inverse absolute track signal C
	21	D	Absolute track signal D
	22	D*	Inverse absolute track signal D
	23	Data*	Inverse data, EnDat interface, Inverse SSI data
	24	Ground	Ground (for internal shield)
	25	-Temp <sup>1)</sup>	Motor temperature sensing KTY84-1C130 (KTY-) Temperature sensor KTY84-1C130 / PTC
Connector type:	25-pin SUB D connector		
Measuring current via temperature sensor connection: 2 mA			

<sup>1)</sup> Accuracy of temperature measurement:  
 - KTY:  $\pm 7$  °C (incl. evaluation)  
 - PTC:  $\pm 5$  °C (incl. evaluation)

<b>NOTICE</b>
<b>Damage to motor due to incorrectly connected KTY temperature sensor</b>
If a KTY temperature sensor is connected with incorrect polarity, it is not possible to detect when the motor overheats. Overheating can cause damage to the motor.
<ul style="list-style-type: none"> <li>• Connect a KTY temperature sensor with the correct polarity.</li> </ul>



<b>! WARNING</b>
<b>Danger to life due to electric shock in the event of voltage flashovers at the temperature sensor</b>
Voltage flashovers in the signal electronics can occur in motors without safe electrical separation of the temperature sensors.
<ul style="list-style-type: none"> <li>• Use temperature sensors that comply with the specifications regarding safe electrical separation.</li> <li>• If safe electrical separation cannot be guaranteed (for linear motors or third-party motors, for example), use a Sensor Module External (SME120 or SME125) or Terminal Module TM120.</li> </ul>

8.5.2.4 X524 Electronics power supply

Table 8- 10 X524: Electronics power supply

	Terminal	Function	Technical data
	+	Electronics power supply	Voltage: 24 V (20.4 ... 28.8 V) Current consumption: max. 0.35 A Max. current through the jumper in the connector: 20 A (15 A according to UL/CSA)
	+	Electronics power supply	
	M	Electronics ground	
	M	Electronics ground	
Type: Screw terminal 2 (Page 336)			

The maximum cable length that can be connected is 30 m.

**Note**

The two "+" or "M" terminals are jumpered in the connector. This ensures that the supply voltage is looped through.

### 8.5.3 Connection example

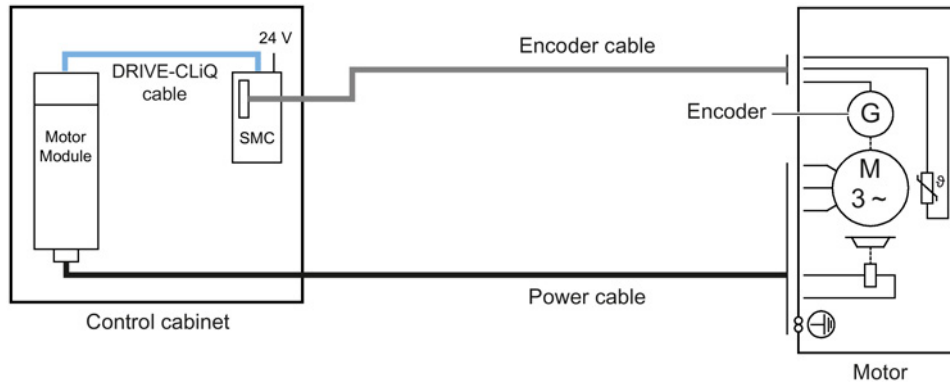

Figure 8-9 Connection of an encoder system via a Sensor Module Cabinet-Mounted (SMC) for a motor without a DRIVE-CLiQ interface

### 8.5.4 Meaning of the LED

Table 8- 11 Meaning of the LEDs on the Sensor Module Cabinet-Mounted SMC20

LED	Color	Status	Description, cause	Remedy	
RDY READY	-	Off	The electronics power supply is missing or outside the permissible tolerance range.	-	
	Green	Continuous light	The component is ready for operation. Cyclic DRIVE-CLiQ communication is taking place.	-	
	Orange	Continuous light	DRIVE-CLiQ communication is being established.	-	
	Red	Continuous light	This component has at least one fault. <b>Note:</b> The LED is activated irrespective of whether the corresponding messages have been reconfigured.	Remove and acknowledge the fault.	
	Green/red	Flashing light 0.5 Hz	Firmware is being downloaded.		-
			Flashing light 2 Hz	Firmware download is complete. The system waits for POWER ON.	Carry out a POWER ON.
	Green / orange or Red / orange	Flashing light	Component recognition via LED is activated <sup>1)</sup> . <b>Note:</b> Both options depend on the LED status when component recognition is activated.	-	

<sup>1)</sup> The parameters for activating component recognition using LEDs can be taken from the following reference:  
Reference: /LH1/ SINAMICS S120/S150 List Manual

### Cause and rectification of faults

Additional information about the cause and resolving faults can be taken from the following references:

- Reference: /LH1/SINAMICS S120/S150 List Manual
- Reference: /IH1/ SINAMICS S120 Commissioning Manual

### 8.5.5 Dimension drawing

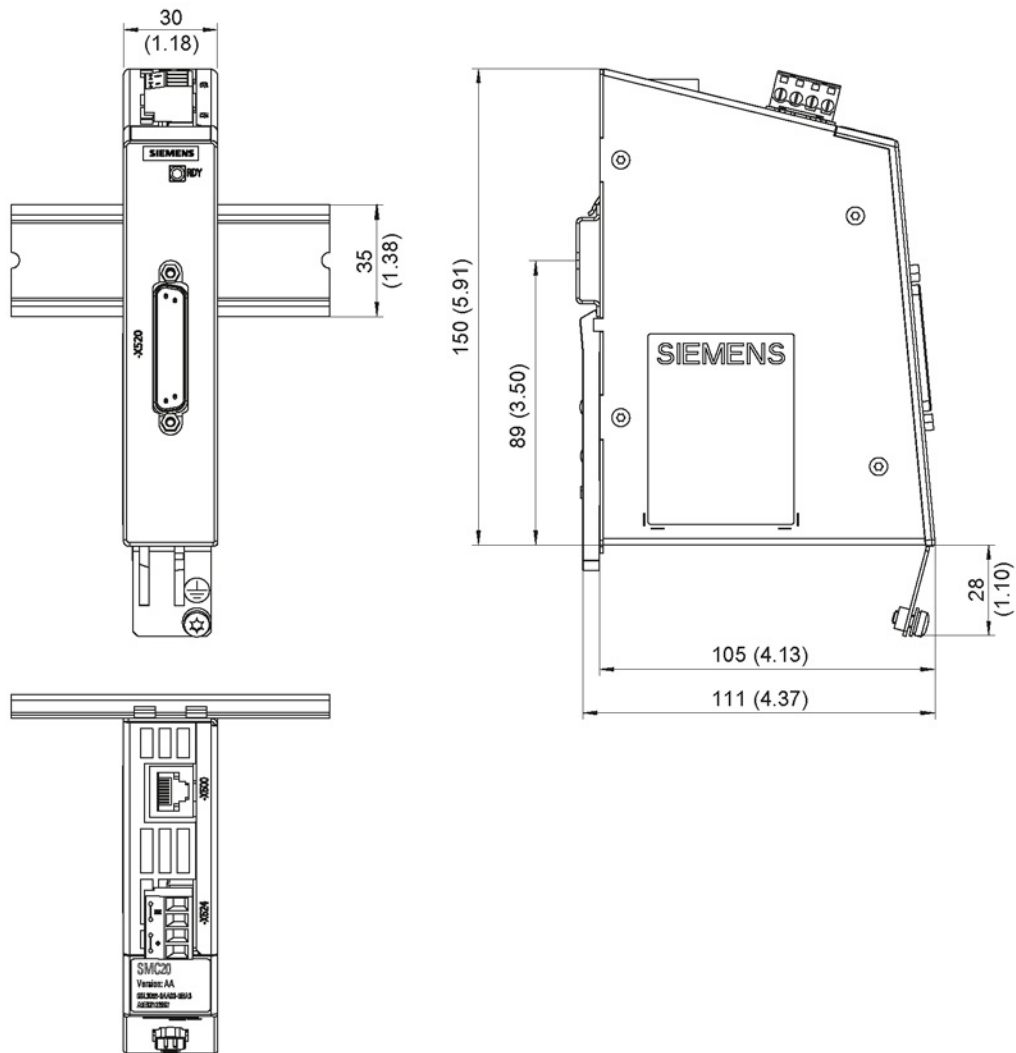

Figure 8-10 Dimension drawing of the Sensor Module Cabinet SMC20, all data in mm and (inches)

## 8.5.6 Mounting

### Installation

1. Tilt the component backwards slightly and attach it to the DIN rail using the hooks.
2. Swivel the component onto the DIN rail until you hear the mounting slide at the rear latch into position.
3. Slide the components along the mounting rail to either the left or right up to their final position.

### Removal

1. First shift the mounting slide downwards at the lug to release the interlocking with the mounting rail.
2. Swivel the component to the front and withdraw it upwards from the DIN rail.

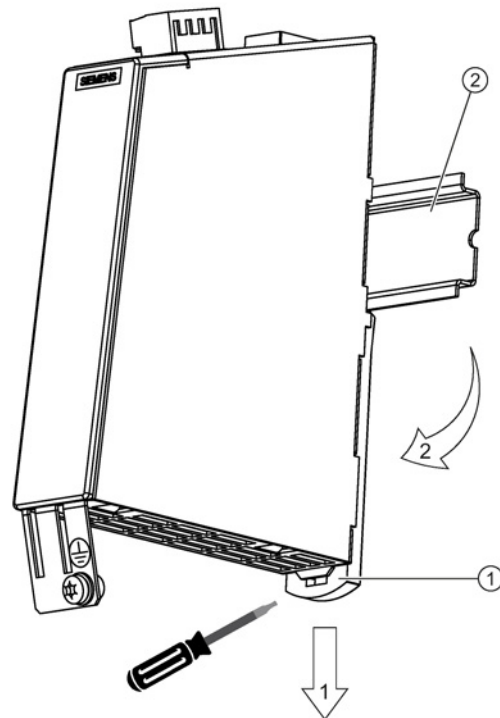

- ① Mounting slide
- ② Mounting rail

Figure 8-11 Removing from a DIN mounting rail

## 8.5.7 Technical data

Table 8- 12 Technical data

6SL3055-0AA00-5BAx	Unit	Value
<b>Electronics power supply</b>		
Voltage	V <sub>DC</sub>	24 (20.4 ... 28.8)
Current (without encoder system)	A <sub>DC</sub>	≤ 0.20
Current (with encoder system)	A <sub>DC</sub>	≤ 0.35
Power loss	W	≤ 10
Max. Cable length	m	30
<b>Encoder system power supply</b>		
Voltage	V <sub>DC</sub>	5 V DC (with remote sense) <sup>1)</sup>
Current	A <sub>DC</sub>	0.35
Encoder frequency that can be evaluated (f <sub>en-coder</sub> )	kHz	≤ 500
SSI baud rate <sup>2)</sup>	kBd	100 - 1000 <sup>3)</sup>
Max. Encoder cable length	m	100
PE/ground connection		At the housing with M4/1.8 Nm screw
Weight	kg	0.45
Degree of protection		IP20 or IPXXB

- 1) A controller compares the encoder system supply voltage - sensed via the Remote Sense cables - with the reference supply voltage of the encoder system, and adjusts the supply voltage for the encoder system at the output of the sensor module until the required supply voltage is obtained directly at the encoder system (only for 5 V encoder system power supply).
- 2) Only possible for SSI encoders with 5 V supply.
- 3) See the diagram "Maximum cable length depending on the SSI baud rate for SSI encoders"

### Note

#### Current controller clock cycle

For a current controller cycle clock of 31.25 μs, use an SMC20 with Article No. 6SL3055-0AA00-5BA3.

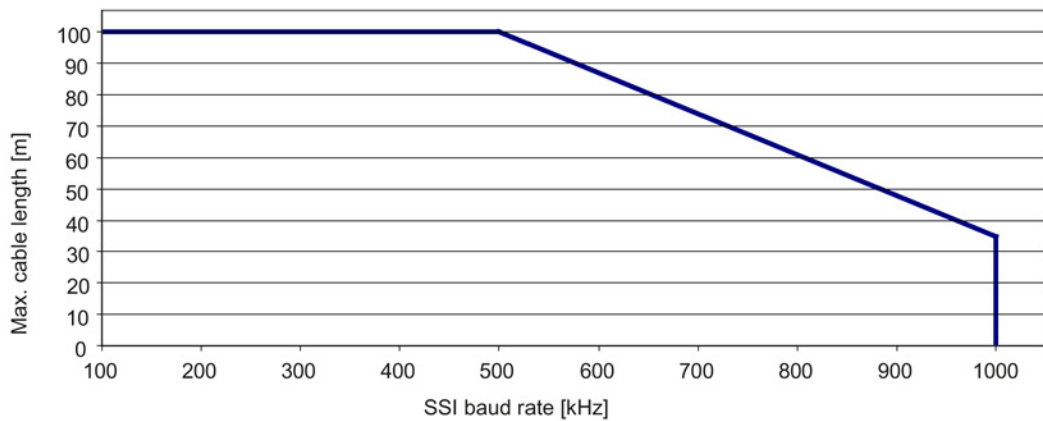

Figure 8-12 Maximum cable lengths depending on the SSI baud rate for SSI encoders



## **8.6 Sensor Module Cabinet-Mounted SMC30**

### **8.6.1 Description**

The Sensor Module Cabinet-Mounted SMC30 is an expansion module for snapping on to a standard mounting rail acc. to EN 60715. It evaluates encoder signals and transmits the speed, actual position, and, if applicable, the motor temperature and reference point via DRIVE-CLiQ to the Control Unit.

The SMC30 is used to evaluate encoder signals from encoders with TTL, HTL, or SSI interfaces.

A combination of TTL/HTL signal and SSI absolute signal is possible at terminals X521/X531, if both signals are derived from the same measured variable.

## 8.6.2 Interface description

### 8.6.2.1 Overview

X500  
DRIVE-CLiQ interface

X524  
Electronics power supply

LEDs

X520  
Encoder system interface  
HTL, TTL with  
Track monitoring,  
SSI

Alternative encoder system  
Interface  
HTL, TTL with  
Track monitoring,  
SSI

Protective conductor connection  
M4 / 1.8 Nm

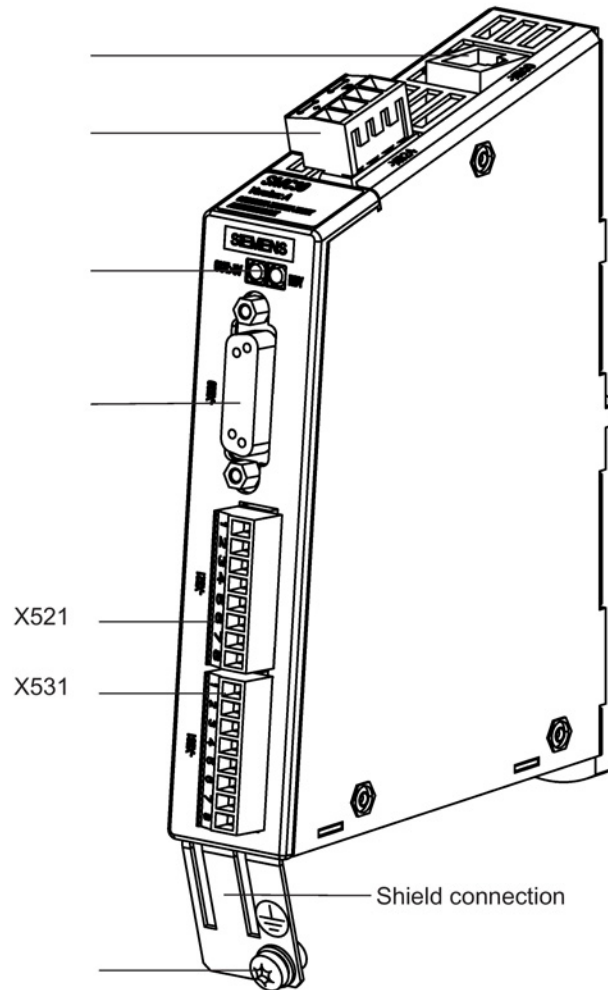
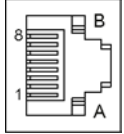

Figure 8-13 Interface description of the SMC30

### 8.6.2.2 X500 DRIVE-CLiQ interface

Table 8- 13 X500: DRIVE-CLiQ interface

	Pin	Signal name	Technical data
	1	TXP	Transmit data +
	2	TXN	Transmit data -
	3	RXP	Receive data +
	4	Reserved, do not use	
	5	Reserved, do not use	
	6	RXN	Receive data -
	7	Reserved, do not use	
	8	Reserved, do not use	
	A	Reserved, do not use	
	B	M (0 V)	Electronics ground
	Connector type	DRIVE-CLiQ socket	

The blanking cover for the DRIVE-CLiQ port is included in the scope of delivery.

Blanking covers (50 x) Article No.: 6SL3066-4CA00-0AA0

## 8.6.2.3 X520 encoder system interface

Table 8- 14 X520: Encoder system interface

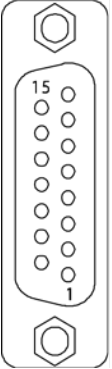
	Pin	Signal name	Technical data
	1	+ Temp <sup>1)</sup>	Motor temperature sensing KTY84-1C130 (KTY+) Temperature sensor KTY84-1C130 / PTC
	2	Clock	SSI clock
	3	Clock*	Inverse SSI clock
	4	P encoder 5 V / 24 V	Encoder power supply
	5	P encoder 5 V / 24 V	
	6	P sense	Sense input encoder power supply
	7	M encoder (M)	Ground, encoder power supply
	8	- Temp <sup>1)</sup>	Motor temperature sensing KTY84-1C130 (KTY-) Temperature sensor KTY84-1C130 / PTC
	9	M sense	Ground sense input
	10	R	Reference signal R
	11	R*	Inverse reference signal R
	12	B*	Inverse incremental signal B
	13	B	Incremental signal B
	14	A* / data*	Inverted incremental signal A/inverted SSI data
	15	A / data	Incremental signal A/SSI data
Connector type:	15-pin Sub-D socket		
Measuring current via temperature sensor connection: 2 mA			

1) Accuracy of temperature measurement:

- KTY:  $\pm 7$  °C (incl. evaluation)
- PTC:  $\pm 5$  °C (incl. evaluation)

**NOTICE****Damage to the encoder due to incorrect supply voltage**

The encoder supply can be parameterized to 5 V or 24 V. Incorrect parameter assignment can cause damage to the encoder.

- Select the appropriate supply voltage.

**NOTICE****Damage to motor in the event of incorrectly connected KTY temperature sensor**

If a KTY temperature sensor is connected with incorrect polarity, it is not possible to detect when the motor overheats. Overheating can cause damage to the motor.

- Connect a KTY temperature sensor with the correct polarity.

Information for parameterizing the KTY temperature sensor can be found in the SINAMICS S120 Function Manual in Chapter "Monitoring and protective functions/thermal monitoring and overload responses".

**! WARNING****Danger to life due to electric shock in the event of voltage flashovers at the temperature sensor**

Voltage flashovers in the signal electronics can occur in motors without safe electrical separation of the temperature sensors.

- Use temperature sensors that comply with the specifications regarding safe electrical separation.
- If safe electrical separation cannot be guaranteed (for linear motors or third-party motors, for example), use a Sensor Module External (SME120 or SME125) or Terminal Module TM120.

## 8.6.2.4 X521 / X531 alternative encoder system interface

Table 8- 15 X521/X531: Alternative encoder system interface

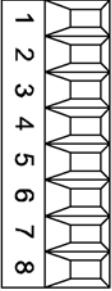
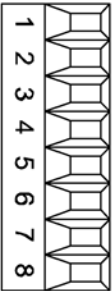
	Pin	Designation	Technical data
X521 	1	A	Incremental signal A
	2	A*	Inverse incremental signal A
	3	B	Incremental signal B
	4	B*	Inverse incremental signal B
	5	R	Reference signal R
	6	R*	Inverse reference signal R
	7	CTRL	Control signal
	8	M	Ground
X531 	1	P_Encoder 5 V / 24 V	Encoder power supply
	2	M_Encoder	Ground, encoder power supply
	3	- Temp <sup>1)</sup>	Motor temperature sensing KTY84-1C130 (KTY-) Temperature sensor KTY84-1C130 / PTC
	4	+ Temp <sup>1)</sup>	Motor temperature sensing KTY84-1C130 (KTY+) Temperature sensor KTY84-1C130 / PTC
	5	Clock	SSI clock
	6	Clock*	Inverse SSI clock
	7	Data	SSI data
	8	Data*	Inverse SSI data
Max. connectable cross-section: 1.5 mm <sup>2</sup> Measuring current via the temperature sensor connection: 2 mA When unipolar HTL encoders are used, A*, B*, and R* on the terminal block must be jumpered with M_Encoder (X531) <sup>2)</sup> .			

1) Accuracy of temperature measurement:

- KTY:  $\pm 7$  °C (incl. evaluation)
- PTC:  $\pm 5$  °C (incl. evaluation)

2) Because the physical transmission media is more robust, the bipolar connection should always be used. The unipolar connection should only be used if the encoder type does not output push-pull signals.



**! WARNING**

**Danger to life through electric shock due to unconnected cable shields**

Hazardous touch voltages can occur through capacitive cross-coupling due to unconnected cable shields.

- Attach the cable shield to the component for the encoder system connection at the terminals.

### Temperature sensor connection

<b>NOTICE</b>
<p><b>Damage to motor in the event of incorrectly connected KTY temperature sensor</b></p> <p>If a KTY temperature sensor is connected with incorrect polarity, it is not possible to detect when the motor overheats. Overheating can cause damage to the motor.</p> <ul style="list-style-type: none"> <li>• Connect a KTY temperature sensor with the correct polarity.</li> </ul>

Information for parameterizing the KTY temperature sensor can be found in the SINAMICS S120 Function Manual in Chapter "Monitoring and protective functions/thermal monitoring and overload responses".

**Note**

The maximum length of the temperature sensor cable is 100 m. The cables must be shielded.



<p> <b>WARNING</b></p> <p><b>Danger to life due to electric shock in the event of voltage flashovers at the temperature sensor</b></p> <p>Voltage flashovers in the signal electronics can occur in motors without safe electrical separation of the temperature sensors.</p> <ul style="list-style-type: none"> <li>• Use temperature sensors that comply with the specifications regarding safe electrical separation.</li> <li>• If safe electrical separation cannot be guaranteed (for linear motors or third-party motors, for example), use a Sensor Module External (SME120 or SME125) or Terminal Module TM120.</li> </ul>
---

### 8.6.2.5 X524 Electronics power supply

Table 8- 16 X524: Electronics power supply

	Terminal	Function	Technical data
	+	Electronics power supply	Voltage: 24 V (20.4 ... 28.8 V) Current consumption: max. 0.55 A Max. current through the jumper in the connector: 20 A (15 A according to UL/CSA)
	+	Electronics power supply	
	M	Electronics ground	
	M	Electronics ground	
Type: Screw terminal 2 (Page 336) <sup>2</sup>			

The maximum cable length that can be connected is 30 m.

**Note**

The two "+" or "M" terminals are jumpered in the connector. This ensures that the supply voltage is looped through.

**8.6.3 Connection examples**

**Connection example 1: HTL encoder, bipolar, with reference signal**

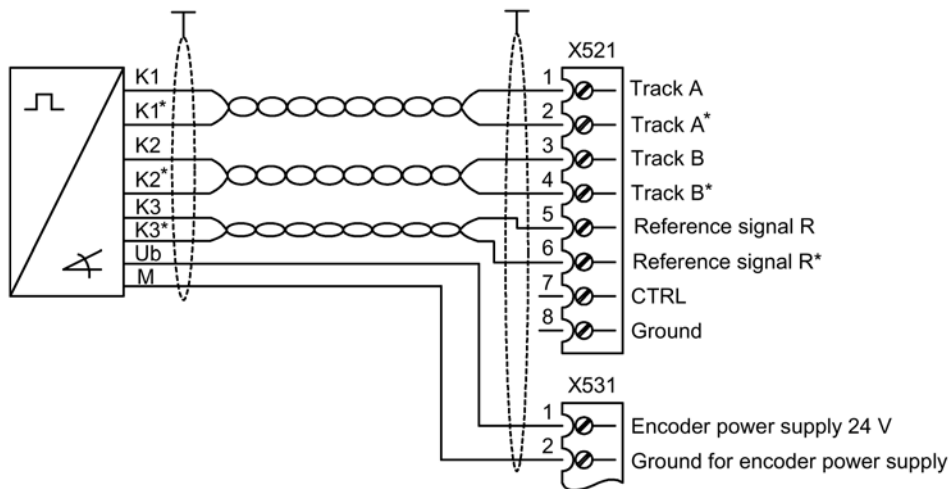

Figure 8-14 Connection example 1: HTL encoder, bipolar, with reference signal

Signal cables must be twisted in pairs to improve immunity to induced noise.



Connection example 2: HTL encoder, unipolar, with reference signal

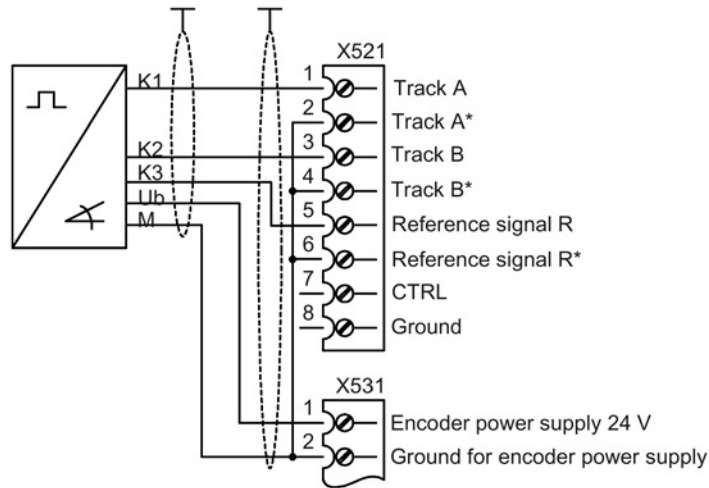

Figure 8-15 Connection example 2: HTL encoder, unipolar, with reference signal<sup>1)</sup>

<sup>1)</sup> Because the physical transmission media is more robust, the bipolar connection should always be used. The unipolar connection should only be used if the encoder type does not output push-pull signals.



Figure 8-16 Photo of connection example 2: SMC30, 30 mm wide

The photo above shows the wire jumpers for connecting unipolar HTL encoders with a reference signal.

## 8.6.4 Meaning of the LEDs

Table 8- 17 Meaning of LEDs on the Sensor Module Cabinet SMC30

LED	Color	Status	Description, cause	Remedy
RDY READY	–	Off	The electronics power supply is missing or outside the permissible tolerance range.	–
	Green	Continuous light	The component is ready for operation. Cyclic DRIVE-CLiQ communication is taking place.	–
	Orange	Continuous light	DRIVE-CLiQ communication is being established.	–
	Red	Continuous light	This component has at least one fault. <b>Note:</b> LED is controlled irrespective of the corresponding messages being reconfigured.	Remedy and acknowledge fault
	Green/red	Flashing light 0.5 Hz	Firmware is being downloaded.	–
	Green/red	Flashing light 2 Hz	Firmware download is complete. The system waits for POWER ON.	Carry out a POWER ON
	Green/orange or Red/orange	Flashing light	Component recognition via LED is activated <sup>1)</sup> . <b>Note:</b> Both options depend on the LED status when component recognition is activated.	–
OUT > 5 V	–	Off	The electronic power supply is missing or outside permissible tolerance range. Power supply $\leq$ 5 V.	–
	Orange	Continuous light	The electronics power supply for the encoder system is available. Power supply > 5 V	–

<sup>1)</sup> The parameters for activating component recognition using LEDs can be taken from the following reference:  
Reference: /LH1/ SINAMICS S120/S150 List Manual

### Cause and rectification of faults

Additional information about the cause and resolving faults can be taken from the following references:

- Reference:/LH1/SINAMICS S120/S150 List Manual
- Reference: /IH1/ SINAMICS S120 Commissioning Manual

### 8.6.5 Dimension drawing

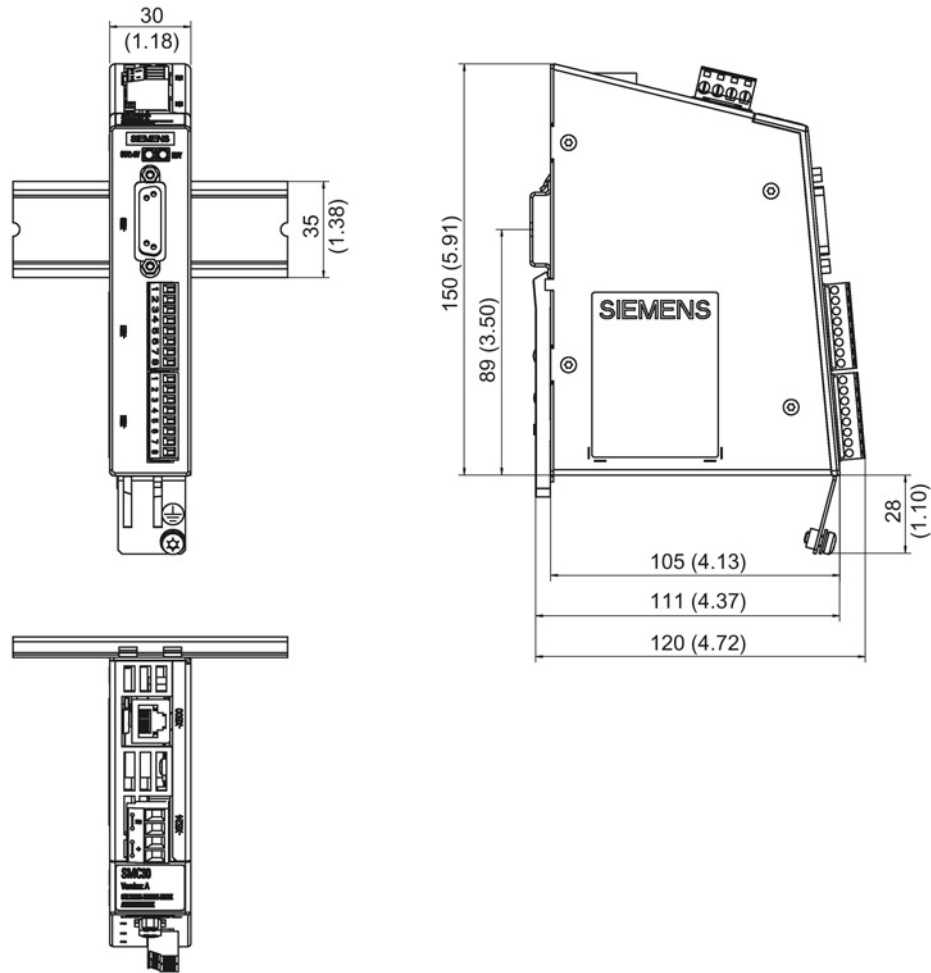

Figure 8-17 Dimension drawing of the Sensor Module Cabinet SMC30, all data in mm and (inches)

## 8.6.6 Mounting

### Installation

1. Tilt the component backwards slightly and attach it to the DIN rail using the hooks.
2. Swivel the component onto the DIN rail until you hear the mounting slide at the rear latch into position.
3. Slide the components along the mounting rail to either the left or right up to their final position.

### Removal

1. First shift the mounting slide downwards at the lug to release the interlocking with the mounting rail.
2. Swivel the component to the front and withdraw it upwards from the DIN rail.

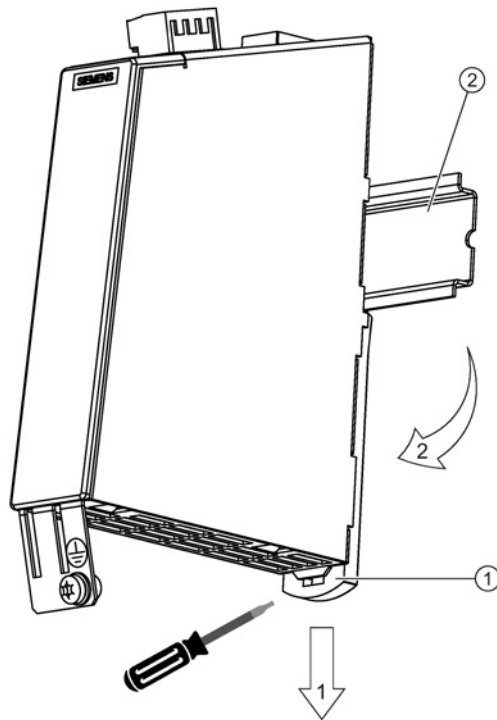

- ① Mounting slide
- ② Mounting rail

Figure 8-18 Removing from a DIN mounting rail

### 8.6.7 Protective conductor connection and shield support

Shield contacts are only required if the system is connected to X521/X531.

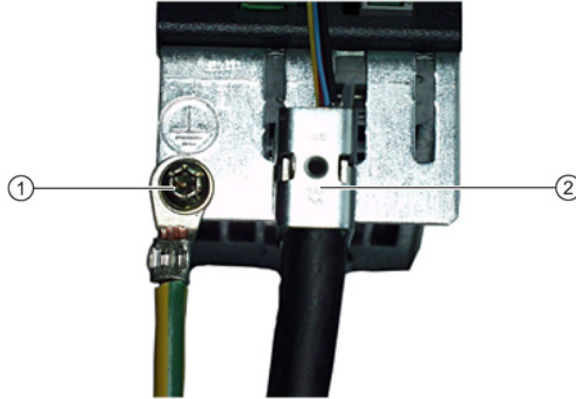

- ① PE conductor connection M4 / 1.8 Nm
- ② Shield connection terminal, Weidmüller company, type: KLBÜ CO1, Article No.: 1753311001

Figure 8-19 Shield support and PE conductor connection

The bending radii of the cables must be observed (see MOTION-CONNECT description).

#### NOTICE

##### Damage or faulty operation due to incorrect shielding or inadmissible cable lengths

If the correct shielding procedures or the permissible cable lengths are not observed, it can cause damage or the machine may malfunction.

- Only use shielded cables.
- Do not exceed the cable lengths stated in the technical data.

## 8.6.8 Technical data

Table 8- 18 Technical data

6SL3055-0AA00-5CA2	Unit	Value
<b>Electronics power supply</b>		
Voltage	V <sub>DC</sub>	24 (20.4 ... 28.8)
Current (without encoder system)	A <sub>DC</sub>	≤ 0.20
Current (with encoder system)	A <sub>DC</sub>	≤ 0.55
Power loss	W	≤ 10
Max. cable length	m	30
<b>Encoder system power supply</b>		
Voltage	V <sub>DC</sub>	5 (with or without remote sense) <sup>1)</sup> or V <sub>DC</sub> - 1 V
Current	A <sub>DC</sub>	0.35
Encoder frequency that can be evaluated (f <sub>encoder</sub> )	kHz	≤ 300
SSI baud rate	kBd	100 - 1000 <sup>2)</sup>
PE/ground connection		At the housing with M4/1.8 Nm screw
Weight	kg	0.45
Degree of protection		IP20 or IPXXB

- 1) A controller compares the encoder system supply voltage - sensed via the Remote Sense cables - with the reference supply voltage of the encoder system, and adjusts the supply voltage for the encoder system at the output of the sensor module until the required supply voltage is obtained directly at the encoder system (only for 5 V encoder system power supply). Remote Sense only to X520.
- 2) See the diagram "Maximum cable length depending on the SSI baud rate for SSI encoders"

## Connectable encoder systems

Table 8- 19 Specification of encoder systems that can be connected

Parameter	Designation	Threshold	Min.	Max.	Unit
High signal level (TTL bipolar at X520 or X521/X531) <sup>1)</sup>	U <sub>Hdiff</sub>		2	5	V
Low signal level (TTL bipolar at X520 or X521/X531) <sup>1)</sup>	U <sub>Ldiff</sub>		-5	-2	V
High signal level (HTL unipolar)	U <sub>H</sub> <sup>3)</sup>	High	17	V <sub>CC</sub>	V
		Low	10	V <sub>CC</sub>	V
Low signal level (HTL unipolar)	U <sub>L</sub> <sup>3)</sup>	High	0	7	V
		Low	0	2	V
High signal level (HTL bipolar) <sup>2)</sup>	U <sub>Hdiff</sub>		3	V <sub>CC</sub>	V
Low signal level (HTL bipolar) <sup>2)</sup>	U <sub>Ldiff</sub>		-V <sub>CC</sub>	-3	V
High signal level (SSI bipolar at X520 or X521/X531) <sup>1)</sup>	U <sub>Hdiff</sub>		2	5	V
Low signal level (SSI bipolar at X520 or X521/X531) <sup>1)</sup>	U <sub>Ldiff</sub>		-5	-2	V

Parameter	Designation	Threshold	Min.	Max.	Unit
Signal frequency	$f_s$		-	300	kHz
Edge clearance	$t_{min}$		100	-	ns
"Zero pulse inactive time" (before and after A=B=high)	$t_{Lo}$		640	$(t_{ALo-BHi} - t_{Hi})/2^4$	ns
"Zero pulse active time" (while A=B=high and beyond) <sup>5)</sup>	$t_{Hi}$		640	$t_{ALo-BHi} - 2*t_{Lo}$ <sup>4)</sup>	ns

- 1) Other signal levels according to the RS 422 standard.
- 2) The absolute level of the individual signals varies between 0 V and  $V_{CC}$  of the encoder system.
- 3) Only with Article No. 6SL3055-0AA00-5CA2 and firmware version 2.5 SP1 or higher can this value be configured using software. For older firmware releases and Article Nos. less than 6SL3055-0AA00-5CA2, the "low" threshold applies.
- 4)  $t_{ALo-BHi}$  is not a specified value, but is the time between the falling edge of track A and the next but one rising edge of track B.
- 5) Additional information on setting the "Zero pulse active time" can be found in the manual: SINAMICS S120, Function Manual, tolerant encoder monitoring for SMC30

Table 8- 20 Encoders that can be connected

	X520 (SUB-D)	X521 (terminal)	X531 (terminal)	Track monitoring	Remote Sense <sup>2)</sup>
HTL bipolar 24 V	Yes	Yes		Yes	no
HTL unipolar 24 V <sup>1)</sup>	Yes	Yes (however, a bipolar connection is recommended) <sup>1)</sup>		no	no
TTL bipolar 24 V	Yes	Yes		Yes	no
TTL bipolar 5 V	Yes	Yes		Yes	At X520
SSI 24 V/5 V	Yes	Yes		no	no
TTL unipolar	no				

- 1) Because the physical transmission media is more robust, the bipolar connection should always be used. The unipolar connection should only be used if the encoder type does not output push-pull signals.
- 2) A controller compares the encoder system supply voltage - sensed via the Remote Sense cables - with the reference supply voltage of the encoder system, and adjusts the supply voltage for the encoder system at the output of the sensor module until the required supply voltage is obtained directly at the encoder system (only for 5 V encoder system power supply).

**Maximum encoder cable lengths**

Table 8- 21 Maximum encoder cable length

Encoder type	Maximum encoder cable length in m
TTL <sup>1)</sup>	100
HTL unipolar <sup>2)</sup>	100
HTL bipolar	300
SSI	100 <sup>3)</sup>

- 1) For TTL encoders at X520 → Remote Sense → 100 m
- 2) Because the physical transmission media is more robust, the bipolar connection should always be used. The unipolar connection should only be used if the encoder type does not output push-pull signals.
- 3) See the diagram "Maximum cable length depending on the SSI baud rate for SSI encoders"

**SSI encoder**

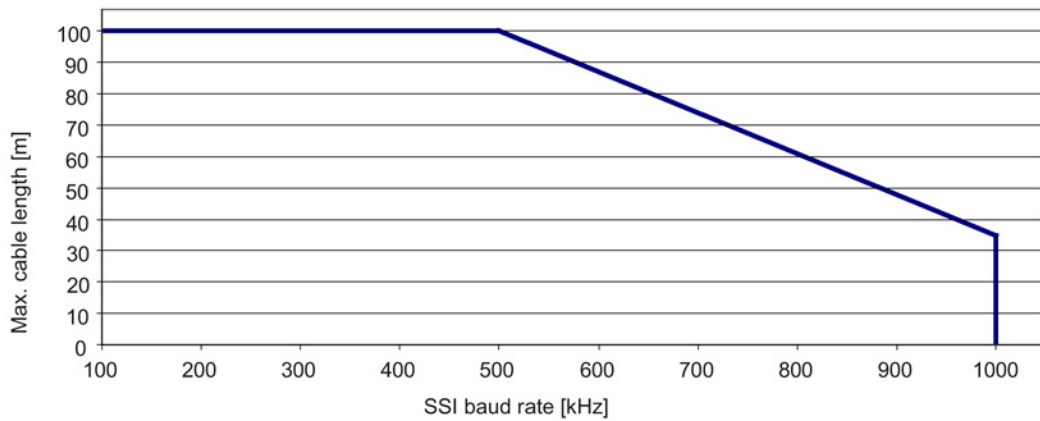

Figure 8-20 Maximum cable lengths depending on the SSI baud rate for SSI encoders

**Encoders with 5 V supply connected to X521/X531**

For encoders with a 5 V supply at X521/X531, the cable length depends on the encoder current (for 0.5 mm<sup>2</sup> cable cross-sections):



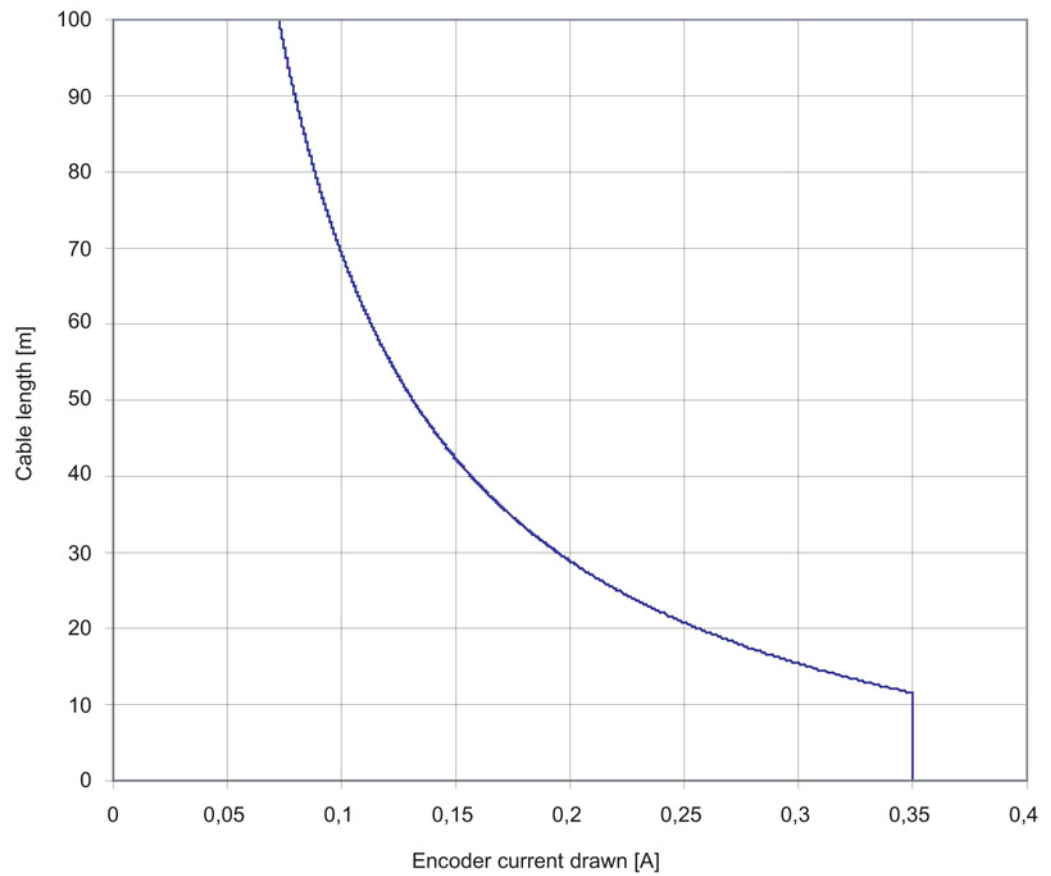

Figure 8-21 Max. cable length as a function of the encoder current drawn

**Encoders without Remote Sense**

When encoders without Remote Sense are used, the permissible cable length is limited to 100 m max. because the voltage drop depends on the cable length and the encoder current.

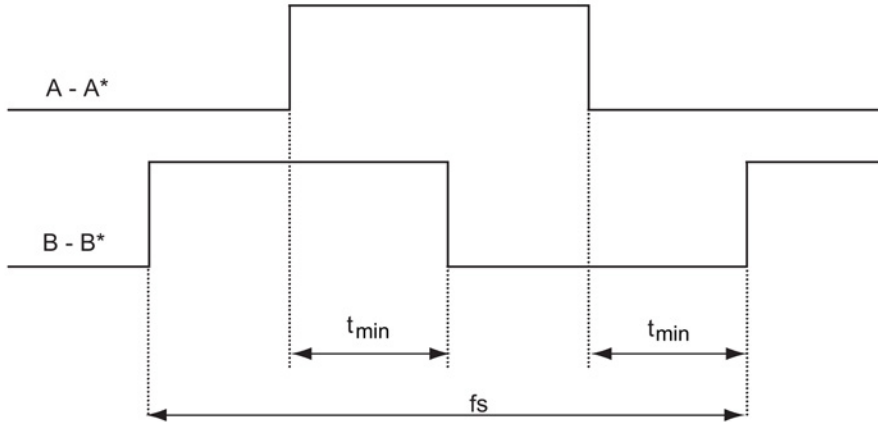

Figure 8-22 Signal characteristic of track A and track B between two edges: Time between two edges with pulse encoders

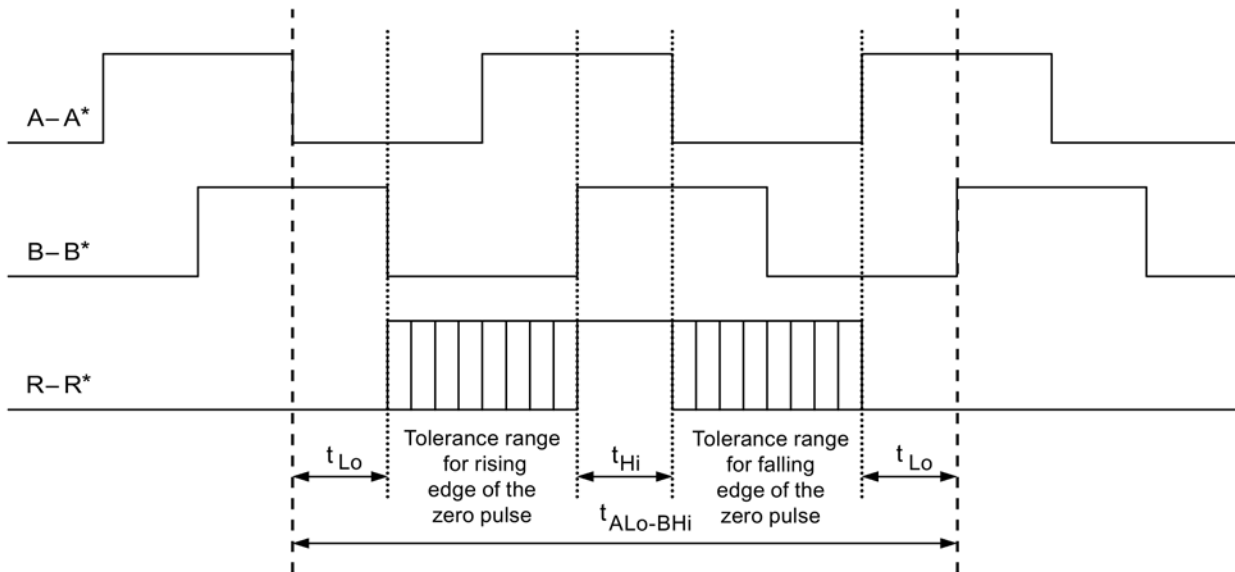

Figure 8-23 Position of the zero pulse to the track signals

## 8.7 Sensor Module Cabinet-Mounted SMC40

### 8.7.1 Description

The Sensor Module Cabinet-Mounted SMC40 is an expansion module for snapping on to a standard mounting rail acc. to EN 60715. It is used to convert encoder signals from absolute encoders with EnDat 2.2 Article No. 22 to DRIVE-CLiQ and send these to the Control Unit. At the SMC40, two encoder systems with EnDat 2.2 Article No. 22 can be connected, which, independent of one another, are converted over to two DRIVE-CLiQ encoder signals.

---

#### Note

##### Permissible encoders

- Only use absolute encoders EnDat 2.2 with Article No. 22. Do not connect an absolute encoder EnDat 2.2 with Article No. 02.
  - Only use absolute encoders (not incremental encoders) with software versions 4.5 and 4.6.
  - Do not use any battery buffered encoders, such as EBI 1135.
- 

#### Configuration and commissioning

To make sure that the Sensor Module Cabinet-Mounted SMC40 is integrated into the topology during first commissioning, you must absolutely observe the following connection conditions:

- Connect at least one of the DRIVE-CLiQ interfaces X500/1 or X500/2 on the SMC40 using DRIVE-CLiQ.
  - Connect one EnDat encoder to the corresponding encoder interface X520/1 (to X500/1) or X520/2 (to X500/2).
  - Operate the SMC40 only in a star topology. The DRIVE-CLiQ sockets X500/1 and X500/2 can **not** be used for a series connection.
- 

#### Note

Later, the SMC40 is integrated into the actual topology only, if the DRIVE-CLiQ interfaces X500/x and the corresponding encoder interfaces X520/x are assigned. Without a connected encoder, it is not possible to subsequently integrate the SMC40 into the topology.

---

#### Temperature signals

If the EnDat2.2 encoder already evaluates the temperature, the temperature signals can be transferred through the SMC40 via DRIVE-CLiQ.

## 8.7.2 Interface descriptions

### 8.7.2.1 Overview

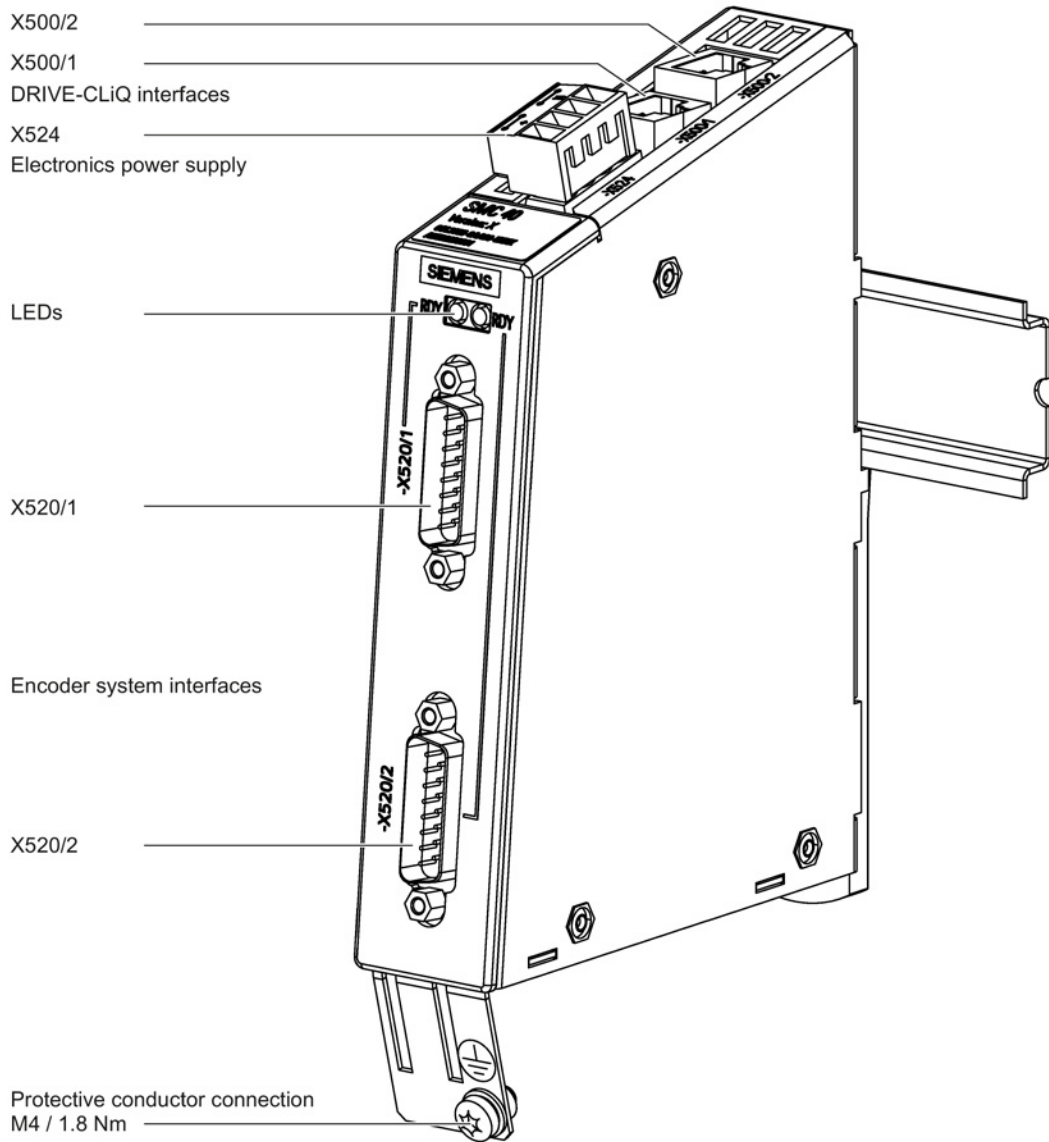

Figure 8-24 Interface overview for the SMC40

### Interface assignment

The DRIVE-CLiQ and encoder interfaces of channel 1 and channel 2 are logically completely independently of one another and permanently assigned.

		X500/1 DRIVE-CLiQ socket	X500/2 DRIVE-CLiQ socket	Left RDY LED	Right RDY LED
X520/1	EnDat 2.2 input	channel 1	---	channel 1	---
X520/2	EnDat 2.2 input	---	channel 2	---	channel 2

Connector X524 for the electronics power supply is used for both channels.

### 8.7.2.2 X500/1 and X500/2 DRIVE-CLiQ interfaces

Table 8- 22 X500/1 and X500/2: DRIVE-CLiQ interfaces

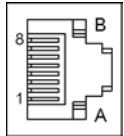
	Pin	Signal name	Technical data
	1	TXP	Transmit data +
	2	TXN	Transmit data -
	3	RXP	Receive data +
	4	Reserved, do not use	
	5	Reserved, do not use	
	6	RXN	Receive data -
	7	Reserved, do not use	
	8	Reserved, do not use	
	A	Reserved, do not use	
	B	M (0 V)	Electronics ground
Connector type	DRIVE-CLiQ socket		

The blanking covers for the DRIVE-CLiQ interfaces are included in the scope of delivery.

Blanking covers (50 x) Article No.: 6SL3066-4CA00-0AA0

#### Note

The maximum DRIVE-CLiQ cable length is 30 m.

8.7.2.3 X520/1 and X520/2 encoder system interfaces

Table 8- 23 X520/1 and X520/2: Encoder system interfaces

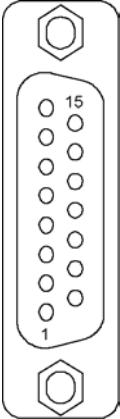
	Pin	Signal name	Technical data
	1	P encoder	Encoder power supply
	2	M encoder	Ground, encoder power supply
	3	Reserved, do not use	
	4	Reserved, do not use	
	5	Data	Data, EnDat interface
	6	Reserved, do not use	
	7	Reserved, do not use	
	8	Data*	Inverse data EnDat interface
	9	P encoder	Encoder power supply
	10	Reserved, do not use	
	11	M encoder	Ground, encoder power supply
	12	Reserved, do not use	
	13	Reserved, do not use	
	14	Clock	Clock, EnDat interface
	15	Clock*	Inverse clock EnDat interface
Connector type:	15-pin SUB D connector		

**Note**

The maximum cable length to encoder systems is 100 m. The specified supply voltage of the encoder must be observed.

**Note**

Pins 1/9 and 2/11 on the SMC40 side and on the encoder side (in the M12 connector, pin 8/2 and pin 5/1) are connected in parallel, and to increase the cable cross-section each must be wired with a separate conductor.



<p><b>⚠ WARNING</b></p> <p><b>Danger to life due to electric shock in the event of voltage flashovers at the temperature sensor</b></p> <p>Voltage flashovers in the signal electronics can occur in motors without safe electrical separation of the temperature sensors.</p> <ul style="list-style-type: none"> <li>• Use temperature sensors that fully comply with the specifications of the safety isolation.</li> <li>• If safe electrical separation cannot be guaranteed (for linear motors or third-party motors, for example), use a Terminal Module TM120.</li> </ul>
--

### 8.7.2.4 X524 Electronics power supply

Table 8- 24 X524: Electronics power supply

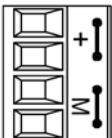
	Terminal	Function	Technical data
	+	Electronics power supply	Voltage: 24 V (20.4 ... 28.8 V)
	+	Electronics power supply	Current consumption: max. 0.35 A
	M	Electronics ground	Maximum current via jumper in connector: 20 A (15 A according to UL/CSA)
	M	Electronics ground	
Type: Screw terminal 2 (Page 336)			

The maximum cable length that can be connected is 30 m.

#### Note

The two "+" or "M" terminals are jumpered in the connector. This ensures that the supply voltage is looped through.

### 8.7.3 Connection example

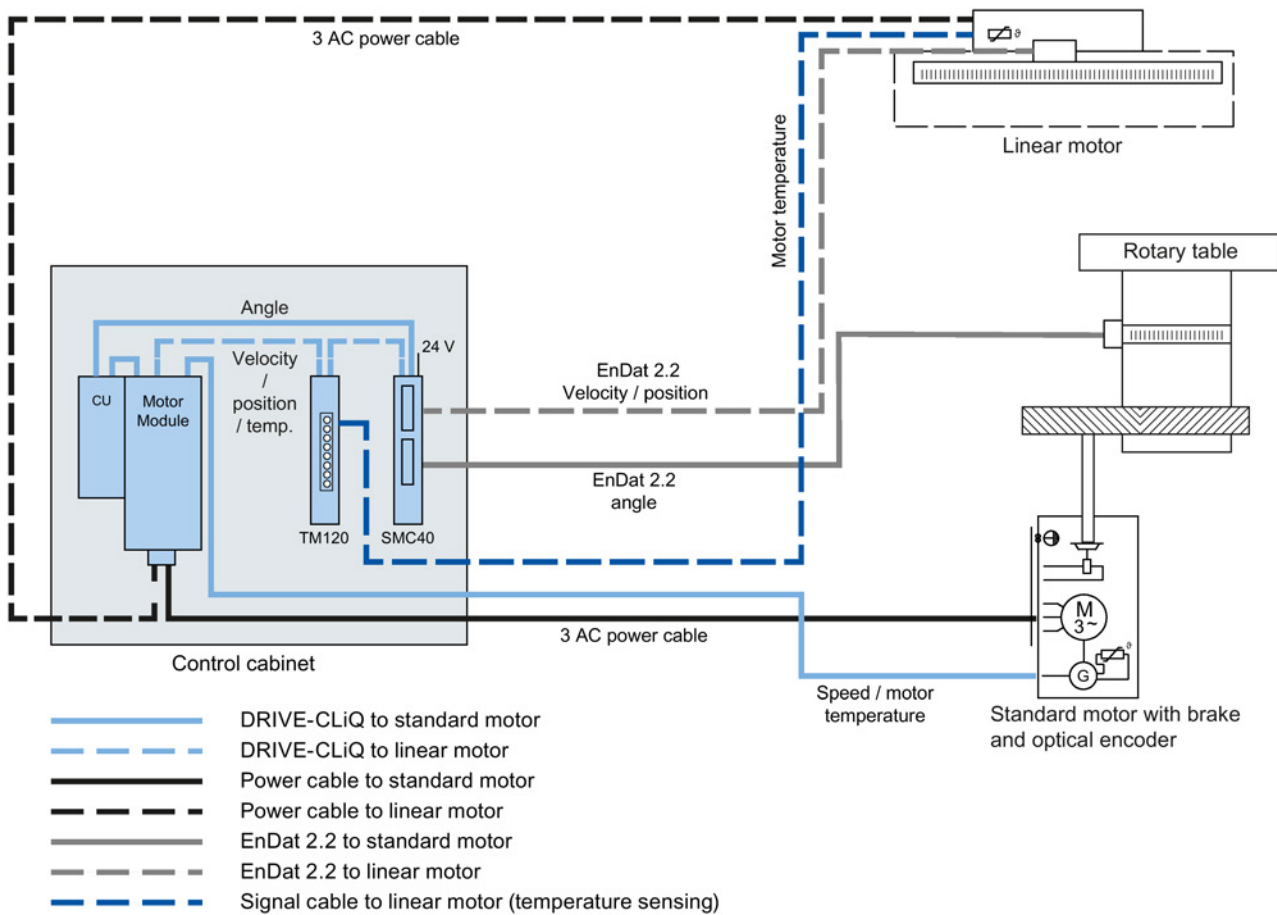

Figure 8-25 Encoder system connection via a Sensor Module Cabinet-Mounted SMC40

The wiring diagram shows two different applications of the SMC40. For each conversion of an EnDat 2.2 encoder signal into a DRIVE-CLiQ signal, a dedicated DRIVE-CLiQ cable must be used, as the electronics in the SMC40 is designed so that each channel is independent. The DRIVE-CLiQ cables cannot be interchanged.

#### Connecting a standard motor with brake and optical encoder

A standard motor with gearbox for a rotary indexing table drive is shown in the connection example. The rotary indexing table has an angular position measuring system with EnDat 2.2 interface. The measured angular data are transferred via EnDat 2.2 to the SMC40 and from there via DRIVE-CLiQ to the Control Unit.

The motor contains an integrated encoder and temperature evaluation, which transfers data via DRIVE-CLiQ directly to the Motor Module.



### Connecting a linear motor without DRIVE-CLiQ interface

From a linear motor with linear scale, velocity and position are first transferred via the EnDat 2.2 connection to the SMC40 and from there, via DRIVE-CLiQ to a Terminal Module TM120.

The temperature sensors of the linear motor supply their analog temperature values directly to the TM120, which guarantees the safe electrical separation of the temperature cable and which transfers the temperature data together with the velocity and position data in the DRIVE-CLiQ protocol to the Motor Module.

## 8.7.4 Meaning of the LEDs

Table 8- 25 Meaning of the LEDs on the Sensor Module Cabinet-Mounted SMC40

LED	Color	Status	Description, cause	Remedy
RDY READY	–	Off	The electronics power supply is missing or outside the permissible tolerance range.	–
	Green	Continuous light	The component is ready for operation. Cyclic DRIVE-CLiQ communication is taking place.	–
	Orange	Continuous light	DRIVE-CLiQ communication is being established.	–
	Red	Continuous light	This component has at least one fault. <b>Note:</b> LED is controlled irrespective of the corresponding messages being reconfigured.	Remove and acknowledge the fault.
	Green/red	Flashing light 2 Hz	Firmware download is complete. The system waits for POWER ON.	Carry out a POWER ON.
	Green/ orange or Red/ orange	Flashing light	Component recognition via LED is activated <sup>1)</sup> . <b>Note:</b> Both options depend on the LED status when component recognition is activated.	–

<sup>1)</sup> The parameter for activating component recognition using LEDs can be taken from the following reference:  
Reference: /LH1/ SINAMICS S120/S150 List Manual

Each channel has a multifunction LED.

### Cause and rectification of faults

Additional information about the cause and resolving faults can be taken from the following references:

- Reference: /LH1/SINAMICS S120/S150 List Manual
- Reference: /IH1/ SINAMICS S120 Commissioning Manual

### 8.7.5 Dimension drawing

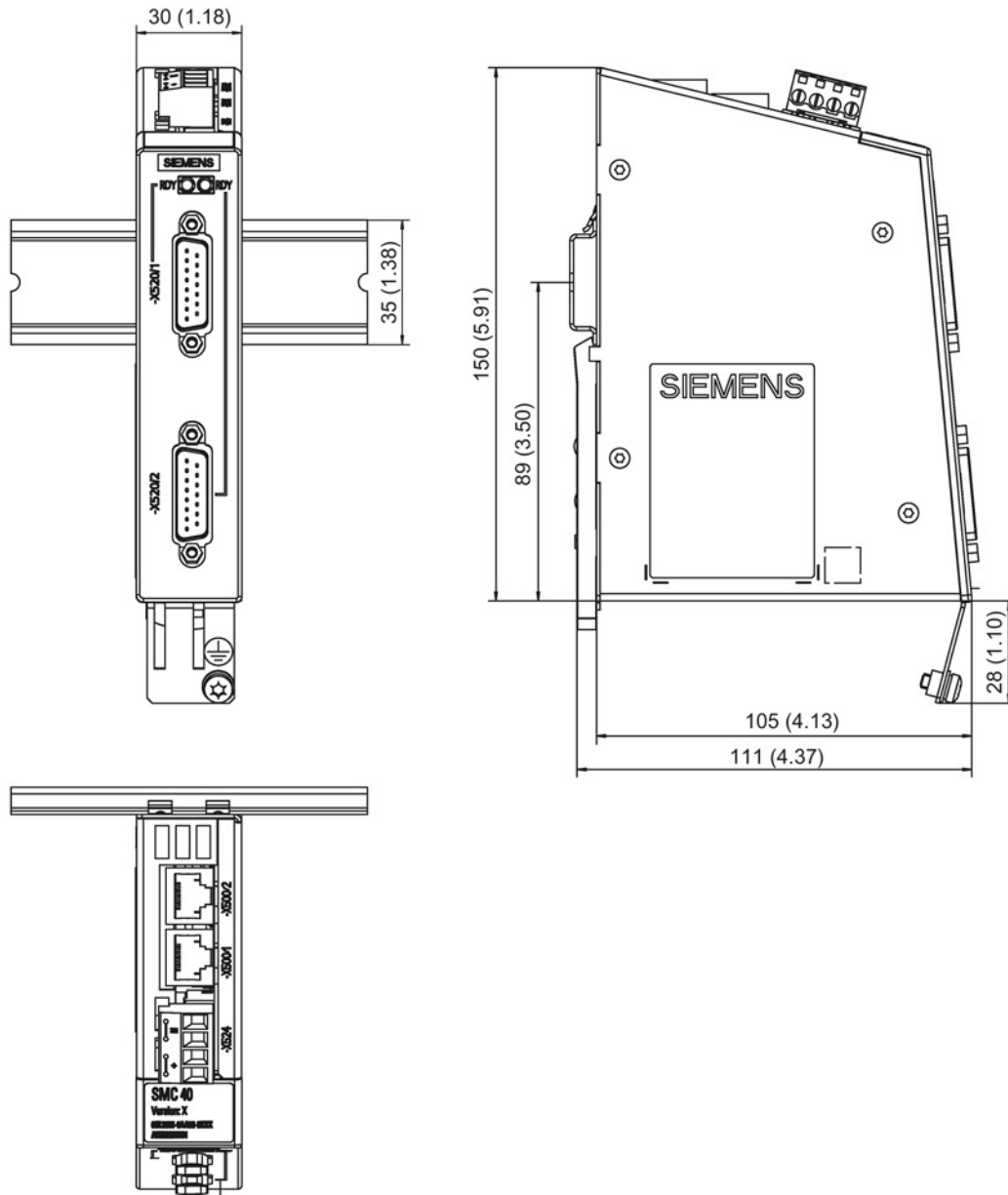

Figure 8-26 Dimension drawing of the Sensor Module Cabinet SMC40, all data in mm and (inches)

## 8.7.6 Installation

### Installation

1. Tilt the component backwards slightly and attach it to the DIN rail using the hooks.
2. Swivel the component onto the DIN rail until you hear the mounting slide at the rear latch into position.
3. Slide the components along the mounting rail to either the left or right up to their final position.

### Removal

1. First shift the mounting slide downwards at the lug to release the interlocking with the mounting rail.
2. Swivel the component to the front and withdraw it upwards from the DIN rail.

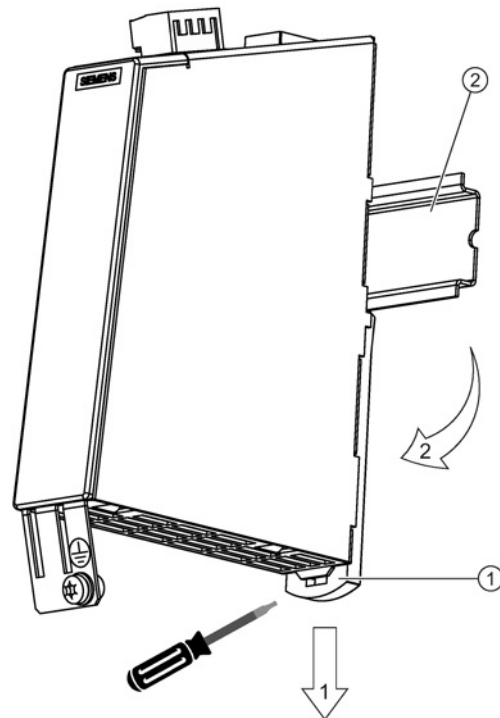

- ① Mounting slide
- ② Mounting rail

Figure 8-27 Removing from a DIN mounting rail

### Mounting clearances

The SMC40 can be installed in the line-up together with other SMC as required. When mounting next to heat sources, the following minimum lateral clearances must be observed:

- 50 mm for Line Modules and Motor Modules
- 100 mm for hotter components (e.g. pulsed resistor)

### 8.7.7 Technical data

Table 8- 26 Technical data

6SL3055-0AA00-5DA0	Unit	Value
<b>Electronics power supply</b>		
Voltage	V <sub>DC</sub>	24 (20.4 ... 28.8)
Current (without encoder system)	A <sub>DC</sub>	≤ 0.10
Current (with encoder system)	A <sub>DC</sub>	≤ 0.35
Power loss	W	≤ 4
Max. cable length	m	30
<b>Encoder system power supply</b>		
Voltage	V <sub>DC</sub>	5.1 (without Remote Sense)
Current	A <sub>DC</sub>	0.5
Evaluable encoder protocol		EnDat 2.2 with order designation 22
Max. encoder cable length	m	100
PE/ground connection		At the housing with M4/1.8 Nm screw
Weight	kg	0.45
Degree of protection		IP20 or IPXXB

## 8.8 Sensor Module External SME20

### 8.8.1 Description

Direct encoder systems outside the cabinet can be connected to the Sensor Module External SME20. The SME20 evaluates these encoder systems and converts the calculated values to DRIVE-CLiQ.

Incremental direct encoder systems with SIN/COS (1 Vpp) and reference signal can be connected.

It is possible to connect a motor with a 17-pole circular connector for the encoder to the 12-pole circular connector of the SME20 using adapter cable 6FX 8002-2CA88-xxxx.

- KTY/PTC temperature sensors can be used for evaluation of the motor temperature.
- The Sensor Module is only suitable for motors without absolute track signals (C/D track):
  - Induction motors (e.g. 1PH)
  - Synchronous motors with pole position identification (e.g. 1FN, 1FW, 1FE)

Neither motor nor encoder data are saved in the SME20.

### 8.8.2 Interface description

#### 8.8.2.1 Overview

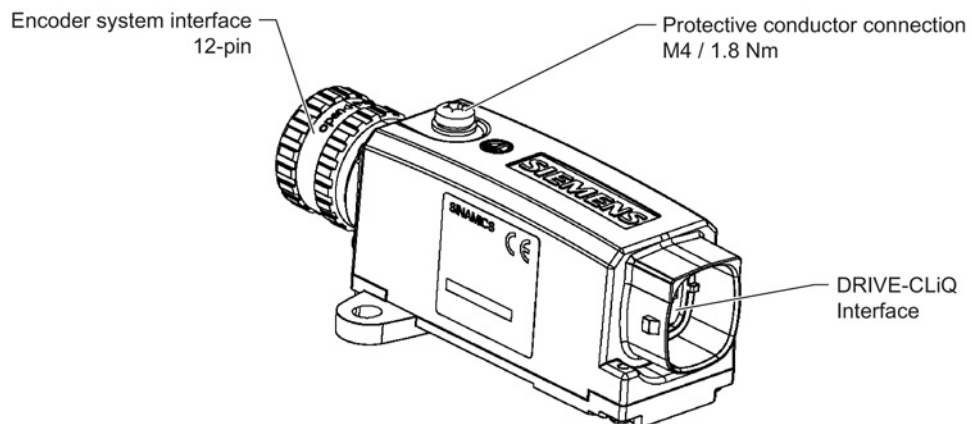
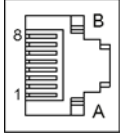

Figure 8-28 Interface description SME20

## 8.8.2.2 DRIVE-CLiQ interface

Table 8- 27 DRIVE-CLiQ interface

	Pin	Signal name	Technical data
	1	TXP	Transmit data +
	2	TXN	Transmit data -
	3	RXP	Receive data +
	4	Reserved, do not use	
	5	Reserved, do not use	
	6	RXN	Receive data -
	7	Reserved, do not use	
	8	Reserved, do not use	
	A	+ (24 V)	Power supply
	B	M (0 V)	Electronics ground
	Connector type	DRIVE-CLiQ socket	
Power consumption max. 0.25 A			

The blanking cover for the DRIVE-CLiQ port to secure the degree of protection IP 67 is not included in the scope of delivery.

Blanking covers (6 units), article number: 6SL3066-4CA01-0AA0

**Note**

Only MOTION-CONNECT DRIVE-CLiQ cables may be used for connections. The maximum cable length is 100 m for MOTION-CONNECT 500, and 75 m for MOTION-CONNECT 800PLUS cables.

### 8.8.2.3 Encoder system interface

Table 8- 28 Encoder system interface SME20

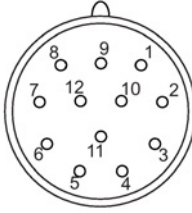
	Pin	Signal name	Technical data
	1	B*	Inverse incremental signal B
	2	P5	Encoder power supply
	3	R	Reference signal R
	4	R*	Inverse reference signal R
	5	A	Incremental signal A
	6	A*	Inverse incremental signal A
	7	-Temp <sup>1) 2)</sup>	Temperature sensor connection <sup>3)</sup> KTY84-1C130 or PTC
	8	B	Incremental signal B
	9	+Temp <sup>1) 2)</sup>	Temperature sensor connection <sup>3)</sup> KTY84-1C130 or PTC
	10	M	Ground, encoder power supply
	11	M	Ground, encoder power supply
	12	P5	Encoder power supply
Connector kit:	12 pole, article number: 6FX2003-0SA12		
Measuring current via temperature sensor connection: 2 mA Blanking cover for encoder system interface: Company Pöppelmann GmbH & Co. KG, Lohne, Article number: GPN 300 F211			

<sup>1)</sup> These connections do not have protective separation!

<sup>2)</sup> Accuracy of temperature measurement:

- KTY: ±7 °C (incl. evaluation)
- PTC: ±5 °C (incl. evaluation)

<sup>3)</sup> Connecting cable: Article number 6FX8002-2CA88-xxxx

**NOTICE**

**Damage to motor in the event of incorrectly connected KTY temperature sensor**

If a KTY temperature sensor is connected with incorrect polarity, it is not possible to detect when the motor overheats. Overheating can cause damage to the motor.

- Connect a KTY temperature sensor with the correct polarity.



**WARNING**

**Danger to life due to electric shock in the event of voltage flashovers at the temperature sensor**

Voltage flashovers in the signal electronics can occur in motors without safe electrical separation of the temperature sensors.

- Use temperature sensors that comply with the specifications regarding safe electrical separation.
- If safe electrical separation cannot be guaranteed (for linear motors or third-party motors, for example), use a Sensor Module External (SME120 or SME125) or Terminal Module TM120.

### 8.8.3 Connection example

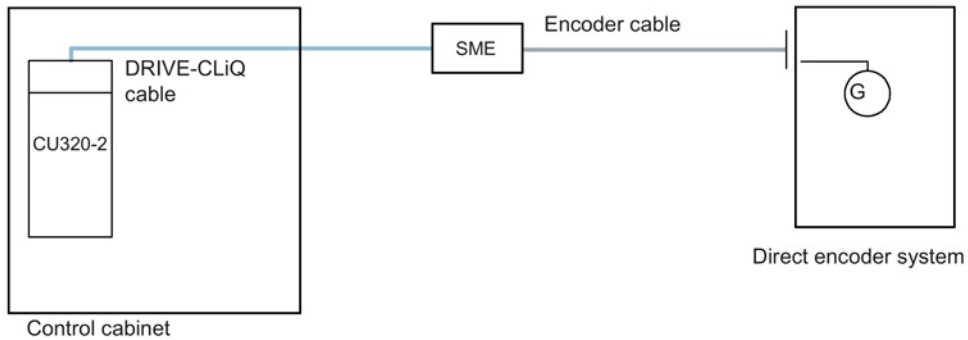

Figure 8-29 Connection of a direct encoder system via a Sensor Module External (SME)



### 8.8.4 Dimension drawing

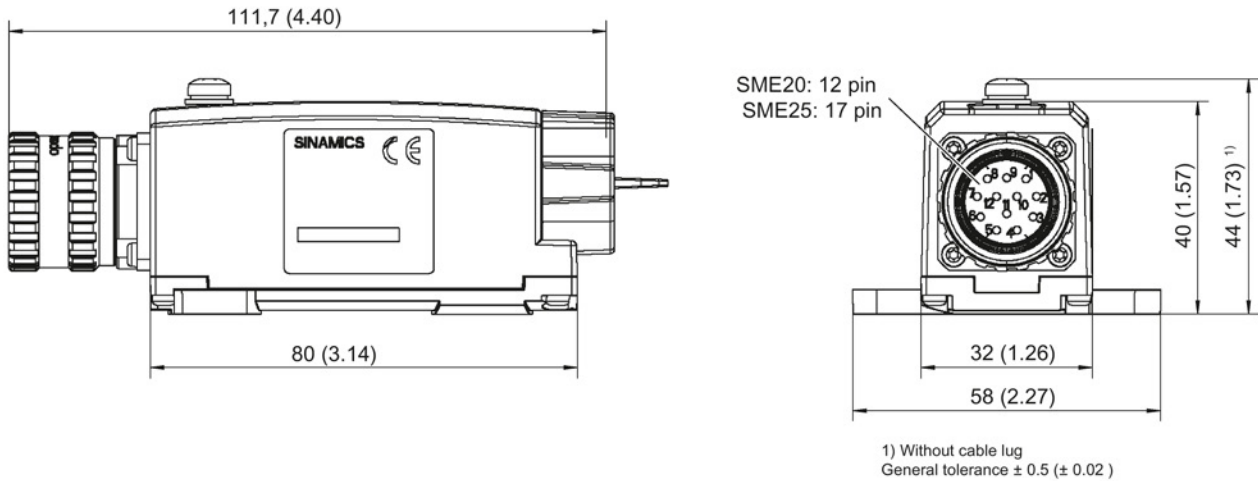
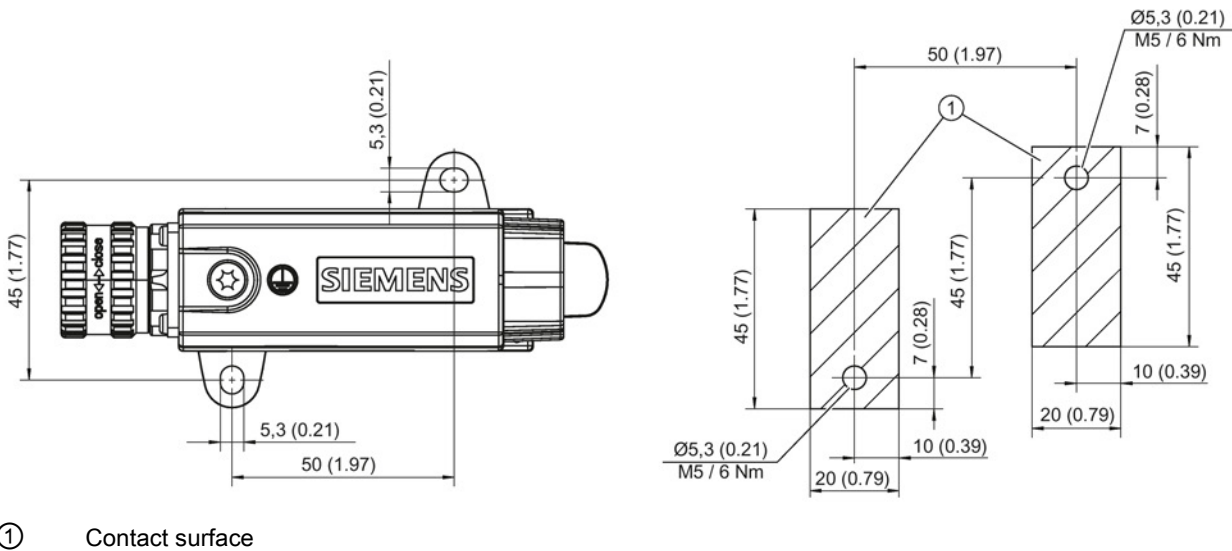

Figure 8-30 Dimension drawing of the Sensor Module External SME20, all data in mm and (inches)

### 8.8.5 Installation



① Contact surface

Figure 8-31 Drilling pattern for installing the SME20/SME25

## Installation

1. Place the drilling pattern on the mounting surface. Make sure that the contact surface is bare, unpainted metal.
2. Drill two holes with  $\varnothing 5.3$  or M5 threaded holes according to the drilling pattern.
3. Fix the Sensor Module to the mounting surface. The tightening torque is 6 Nm.

### 8.8.6 Technical data

Table 8- 29 Technical data

6SL3055-0AA00-5EAx	Unit	Value
<b>Electronics power supply</b>		
Voltage	$V_{DC}$	24 (20.4 ... 28.8)
Current (without encoder system)	$A_{DC}$	$\leq 0.15$
Current (with encoder system)	$A_{DC}$	$\leq 0.25$
Power loss	W	$\leq 4$
Max. cable length	m	30
<b>Encoder system power supply</b>		
Voltage	$V_{DC}$	5
Current	$A_{DC}$	0.35
Encoder frequency that can be evaluated ( $f_{encoder}$ )	kHz	$\leq 500$
PE/ground connection		At the housing with M4/1.8 Nm screw
Weight	kg	0.31
Degree of protection		IP67

#### Note

##### Current controller clock cycle

For a current controller clock cycle of 31.25  $\mu\text{s}$ , an SME20 with article number 6SL3055-0AA00-5EA3 must be used.

The maximum cable length for the encoder system interface depends on the current consumption of the encoder system and the cross-section of the wire in the cable. However, the maximum length is 30 m. The figure below applies to encoder systems that operate in the supply voltage range between 4.75 V and 5.25 V. The sample parameters shown are 0.28 mm<sup>2</sup> cross-section (0.14 mm<sup>2</sup> supply plus 0.14 mm<sup>2</sup> Remote Sense wires) and 0.64 mm<sup>2</sup> (0.5 mm<sup>2</sup> supply plus 0.14 mm<sup>2</sup> Remote Sense wires).

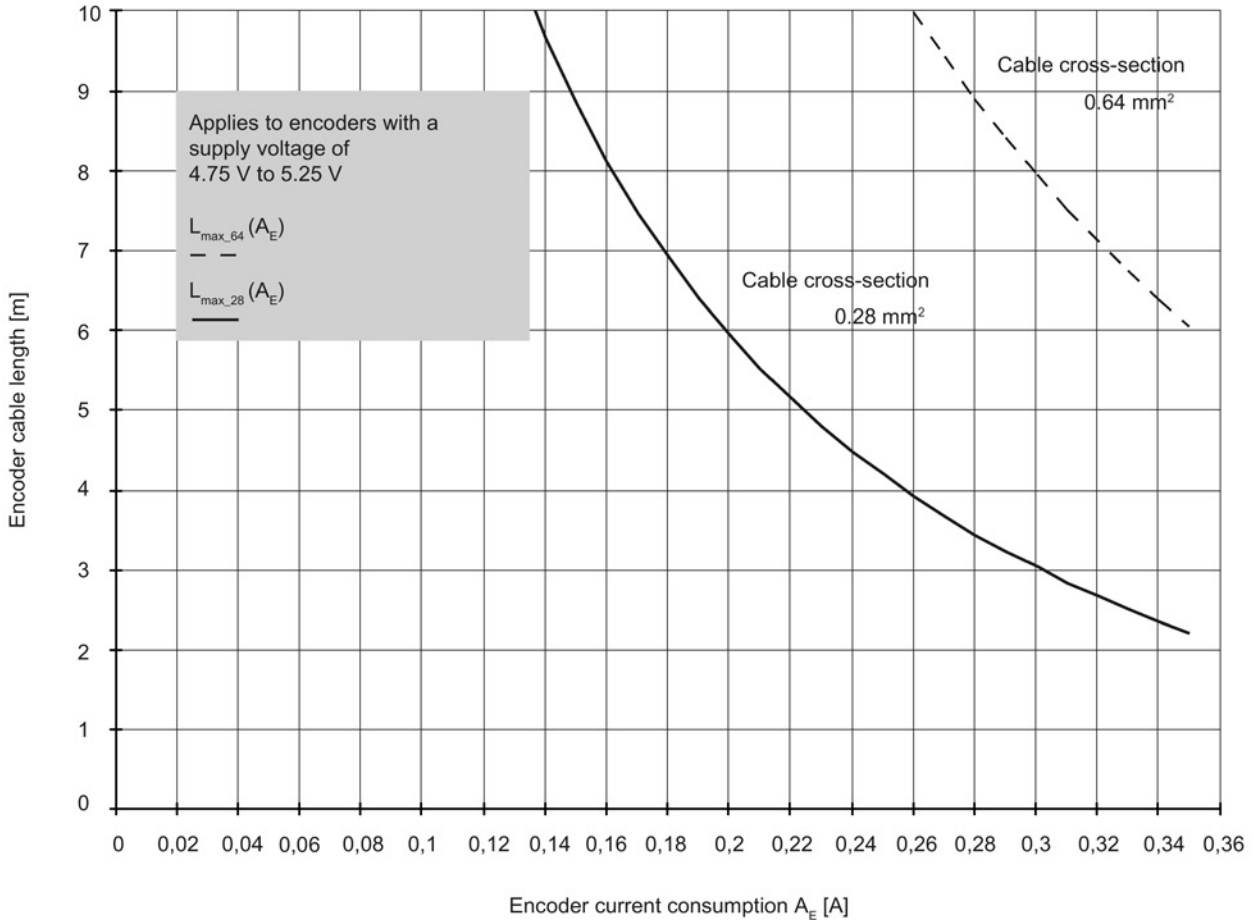

Figure 8-32 Max. cable length as a function of the current drawn by the encoder system

In addition to the encoder systems for the supply voltage range of 4.75 V to 5.25 V in the diagram above, encoder systems are also available for the extended range down to 3.6 V. These are generally operable using encoder system cables up to 30 m in length, provided that the total cross-section of the supply plus Remote Sense wires does not fall below 0.14 mm<sup>2</sup>.

## 8.9 Sensor Module External SME25

### 8.9.1 Description

Direct encoder systems outside the cabinet can be connected to the Sensor Module External SME25. The SME25 evaluates these encoder systems and converts the calculated values to DRIVE-CLiQ.

Direct encoder systems with EnDat 2.1, EnDat 2.2 order designation 02 or SSI with SIN/COS (1 Vpp) incremental signals can be connected, however without reference signal.

Neither motor nor encoder data are saved in the SME25.

### 8.9.2 Interface description

#### 8.9.2.1 Overview

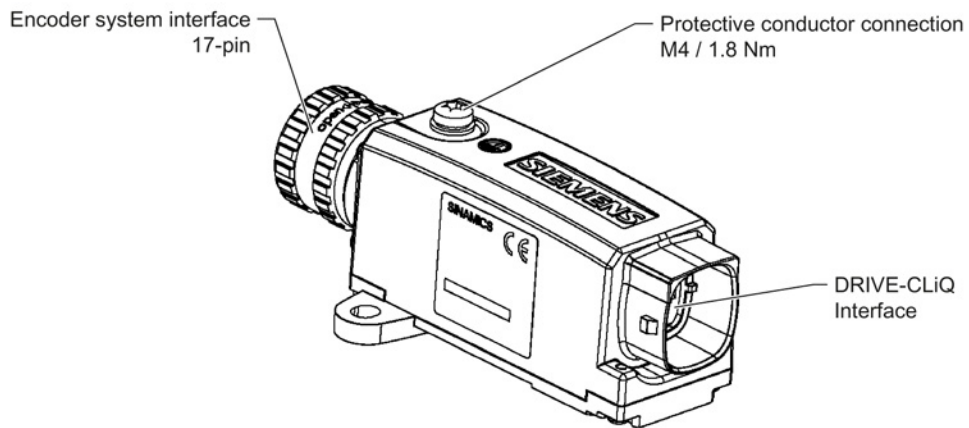
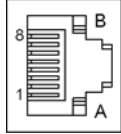

Figure 8-33 Interface description SME25

### 8.9.2.2 DRIVE-CLiQ interface

Table 8- 30 DRIVE-CLiQ interface

	Pin	Signal name	Technical data
	1	TXP	Transmit data +
	2	TXN	Transmit data -
	3	RXP	Receive data +
	4	Reserved, do not use	
	5	Reserved, do not use	
	6	RXN	Receive data -
	7	Reserved, do not use	
	8	Reserved, do not use	
	A	+ (24 V)	Power supply
	B	M (0 V)	Electronics ground
Connector type	DRIVE-CLiQ socket		
Power consumption max. 0.25 A			

The blanking cover for the DRIVE-CLiQ port to secure the degree of protection IP 67 is not included in the scope of delivery.

Blanking covers (6 units), article number: 6SL3066-4CA01-0AA0

#### Note

Only MOTION-CONNECT DRIVE-CLiQ cables may be used for connections. The maximum cable length is 100 m for MOTION-CONNECT 500, and 75 m for MOTION-CONNECT 800PLUS cables.

8.9.2.3 Encoder system interface

Table 8- 31 Encoder system interface SME25

	Pin	Signal name	Technical data
	1	P5	Encoder power supply
	2	Reserved, do not use	
	3	Reserved, do not use	
	4	M	Ground, encoder power supply
	5	Reserved, do not use	
	6	Reserved, do not use	
	7	P5	Encoder power supply
	8	Clock	Clock, EnDat interface, SSI clock
	9	Clock*	Inverted clock, EnDat interface, inverted SSI clock
	10	M	Ground, encoder power supply
	11	Housing potential	
	12	B	Incremental signal B
	13	B*	Inverse incremental signal B
	14	Data	Data, EnDat interface, SSI data
	15	A	Incremental signal A
	16	A*	Inverse incremental signal A
	17	Data*	Inverse data, EnDat interface, Inverse SSI data
Connector kit:	17 pole, article number: 6FX2003-0SA17		
Blanking plate for encoder system interface: Company Pöppelmann GmbH & Co. KG, Lohne, Article number: GPN 300 F211			

8.9.3 Connection example

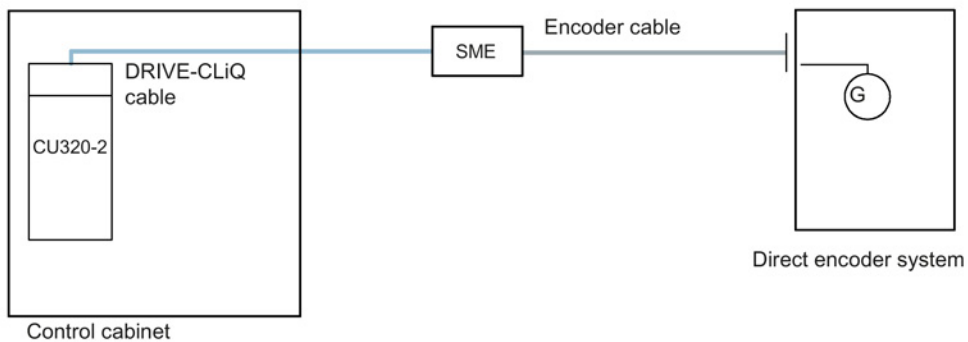

Figure 8-34 Connection of a direct encoder system via a Sensor Module External (SME)

### 8.9.4 Dimension drawing

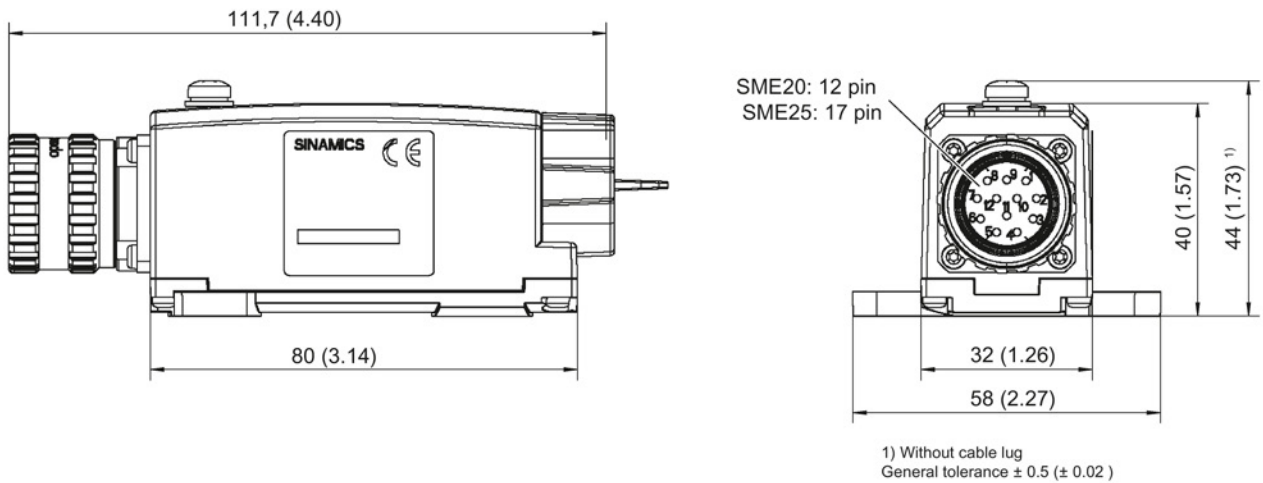

Figure 8-35 Dimension drawing of the Sensor Module External SME25, all data in mm and (inches)

### 8.9.5 Installation

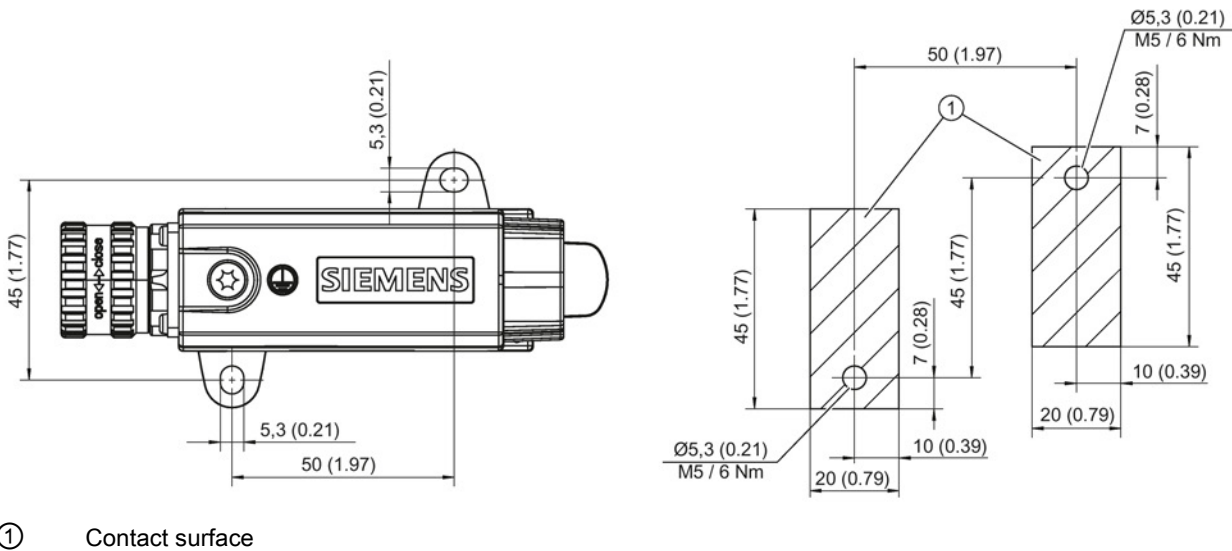

Figure 8-36 Drilling pattern for installing the SME20/SME25

## Installation

1. Place the drilling pattern on the mounting surface. Make sure that the contact surface is bare, unpainted metal.
2. Drill two holes with  $\varnothing 5.3$  or M5 threaded holes according to the drilling pattern.
3. Fix the Sensor Module to the mounting surface. The tightening torque is 6 Nm.

## 8.9.6 Technical data

Table 8- 32 Technical data

6SL3055-0AA00-5HAx	Unit	Value
<b>Electronics power supply</b>		
Voltage	$V_{DC}$	24 (20.4 ... 28.8)
Current (without encoder system)	$A_{DC}$	$\leq 0.15$
Current (with encoder system)	$A_{DC}$	$\leq 0.25$
Power loss	W	$\leq 4$
Max. cable length	m	30
<b>Encoder system power supply</b>		
Voltage	$V_{DC}$	5
Current	$A_{DC}$	0.35
Encoder frequency that can be evaluated ( $f_{encoder}$ )	kHz	$\leq 500$
SSI/EnDat baud rate	kBd	100
PE/ground connection		At the housing with M4 screw Tightening torque: 1.8 Nm
Weight	kg	0.31
Degree of protection		IP67

### Note

#### Current controller clock cycle

For a current controller clock cycle of 31.25  $\mu\text{s}$ , an SME25 with article number 6SL3055-0AA00-5HA3 must be used.



The maximum cable length for the encoder system interface depends on the current consumption of the encoder system and the cross-section of the wire in the cable. However, the maximum length is 30 m. The figure below applies to encoder systems that operate in the supply voltage range between 4.75 V and 5.25 V. The sample parameters shown are 0.28 mm<sup>2</sup> cross-section (0.14 mm<sup>2</sup> supply plus 0.14 mm<sup>2</sup> Remote Sense wires) and 0.64 mm<sup>2</sup> (0.5 mm<sup>2</sup> supply plus 0.14 mm<sup>2</sup> Remote Sense wires).

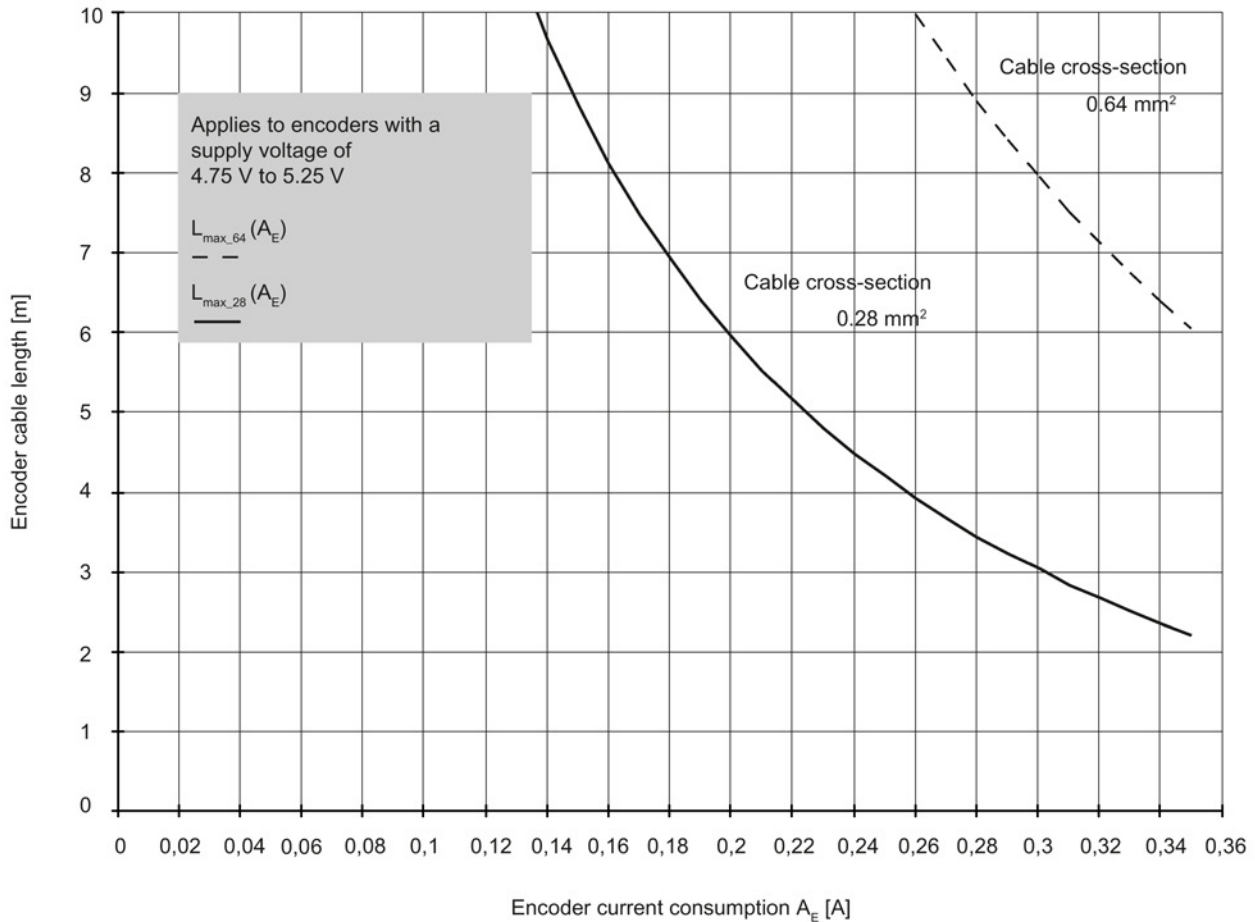

Figure 8-37 Max. cable length as a function of the current drawn by the encoder system

In addition to the encoder systems for the supply voltage range of 4.75 V to 5.25 V in the diagram above, encoder systems are also available for the extended range down to 3.6 V. These are generally operable using encoder system cables up to 30 m in length, provided that the total cross-section of the supply plus Remote Sense wires does not fall below 0.14 mm<sup>2</sup>.

## 8.10 Sensor Module External SME120

### 8.10.1 Description

Direct encoder systems outside the cabinet can be connected to the Sensor Module External SME120. The SME120 evaluates these encoder systems and converts the calculated values to DRIVE-CLiQ. Neither motor nor encoder data are saved in the SME120. Incremental direct encoder systems with SIN/COS (1 Vpp) and reference signal can be connected.

An SME120 is always used when the temperature signals of the motors do not have protective separation or where this separation is not possible for certain reasons.

The SME120 is especially used for linear motor applications. A Hall sensor box can be connected to determine the commutation position of a linear motor.

### 8.10.2 Safety instructions for Sensor Modules External

The following safety instructions specifically apply for Sensor Modules External SME12x.

---

#### Note

When handling/using a Sensor Module External, you must also observe the safety instructions for Sensor Modules as well as the safety instructions in Chapter 1 (Page 19).

---

A Sensor Module External SME12x is a device belonging to safety class I.

 **WARNING**

**Death or severe injury can occur when an SME12x is incorrectly used and handled.**

When an SME12x is incorrectly used and handled, protective devices can be disabled; which means that death or severe injury can occur when touching.

- It is mandatory that you connect a protective conductor with a minimum cross-section of 2.5 mm<sup>2</sup> in order to guarantee safe electrical separation.
- In order to ensure degree of protection IP67, close all connections, even connections that are not used, with connectors or suitable sealing caps. You must observe the specified torques.
- Before commissioning, always replace the plastic covers of connections X100 to X500 using the corresponding connectors, as otherwise the Sensor Modules External SME12x will not conform with degree of protection IP67.
- Under no circumstances open the Sensor Modules, as this can mean that they are no longer properly sealed! Only a certified SIEMENS service center should carry out repair and maintenance work.
- If it appears that the Sensor Module packaging has been damaged by water, do not commission the Sensor Module.

**NOTICE**

**Damage caused by connecting a grounded encoder system power supply**

The devices can be damaged by connecting encoder systems with grounded encoder system power supplies.

- Only connect those encoder systems where the power supply is **not** grounded.

### 8.10.3 Interface description

#### 8.10.3.1 Overview

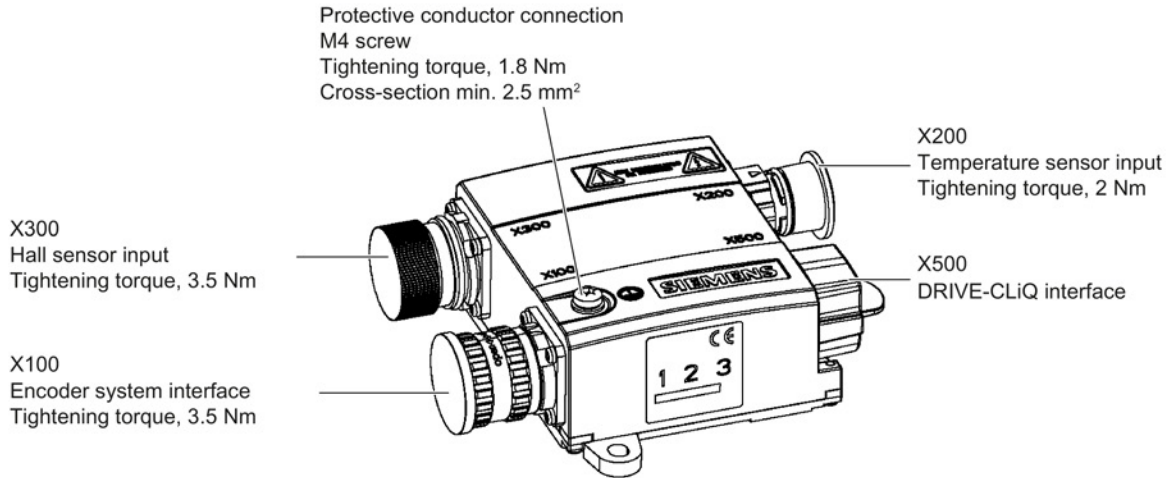

Figure 8-38 Interface description, SME120

#### 8.10.3.2 X100 encoder system interface

Table 8- 33 X100: Encoder system interface

	Pin	Signal name	Technical data
	1	B*	Inverse incremental signal B
	2	P5	Encoder power supply
	3	R	Reference signal R
	4	R*	Inverse reference signal R
	5	A	Incremental signal A
	6	A*	Inverse incremental signal A
	7	Reserved, do not use	
	8	B	Incremental signal B
	9	Reserved, do not use	
	10	M	Ground, encoder power supply
	11	M	Ground, encoder power supply
	12	P5	Encoder power supply
Connector kit:	12 pole, article number: 6FX2003-0SA12		
Blanking plate for encoder system interface: Company Pöppelmann GmbH & Co. KG, Lohne, Article number: GPN 300 F211,			

### 8.10.3.3 X200 thermistor sensor input

Table 8- 34 X200: Temperature sensor input

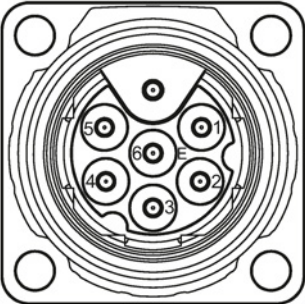
	Pin	Function	Technical data
	1	-Temp	Temperature sensor connection KTY84-1C130/PTC/bimetallic switch with NC contact In linear and torque motor applications, connect the KTY84-1C130 motor temperature sensor here
	2	+Temp	
	3	+Temp	Temperature sensor connection KTY84-1C130/PTC/bimetallic switch with NC contact In linear and torque motor applications, connect the PTC triple element 1 or bimetallic switch here
	4	-Temp	
	5	+Temp	Temperature sensor connection KTY84-1C130/PTC/bimetallic switch with NC contact In torque motor applications, connect the PTC triple element 2 here
	6	-Temp	
Connector kit:	6+1-pole, article number: 6FX2003-0SU07		
Measuring current via temperature sensor connection: 2 mA			
Accuracy of temperature measurement: - KTY: $\pm 7$ °C (incl. evaluation) - PTC: $\pm 5$ °C (incl. evaluation)			

<b>NOTICE</b>
<p><b>Overheating of the motor through jumpering the temperature sensor connections</b></p> <p>Jumpering of the temperature sensor connections "+ Temp" and "- Temp" results in incorrect measurement results. Damage to the motor can result if the overheating is not detected.</p> <ul style="list-style-type: none"> <li>• When using several temperature sensors, separately connect the individual sensors to "+ Temp" and "- Temp".</li> </ul>

## 8.10.3.4 X300 hall sensor input

Table 8- 35 X300: Hall sensor input

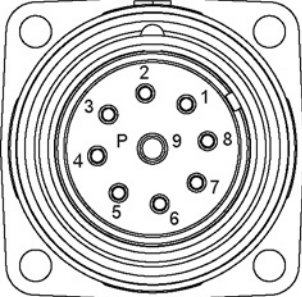
	Pin	Signal name	Technical data
	1	C	Absolute track signal C
	2	C*	Inverse absolute track signal C
	3	P5	Encoder power supply
	4	M	Ground, encoder power supply
	5	D	Absolute track signal D
	6	D*	Inverse absolute track signal D
	7	Not assigned	
	8	Not assigned	
	9	Ground	Ground (for internal shield)

## 8.10.3.5 X500 DRIVE-CLiQ interface

Table 8- 36 X500: DRIVE-CLiQ interface

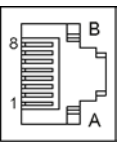
	Pin	Signal name	Technical data
	1	TXP	Transmit data +
	2	TXN	Transmit data -
	3	RXP	Receive data +
	4	Reserved, do not use	
	5	Reserved, do not use	
	6	RXN	Receive data -
	7	Reserved, do not use	
	8	Reserved, do not use	
	A	+ (24 V)	Power supply
	B	M (0 V)	Electronics ground
Connector type	DRIVE-CLiQ socket		
Power consumption max. 0.30 A			

The blanking cover for the DRIVE-CLiQ port to secure the degree of protection IP 67 is not included in the scope of delivery.

Blanking covers (6 units), article number: 6SL3066-4CA01-0AA0

**Note**

Only MOTION-CONNECT DRIVE-CLiQ cables may be used for connections. The maximum cable length is 100 m for MOTION-CONNECT 500, and 75 m for MOTION-CONNECT 800PLUS cables.

### 8.10.4 Connection examples

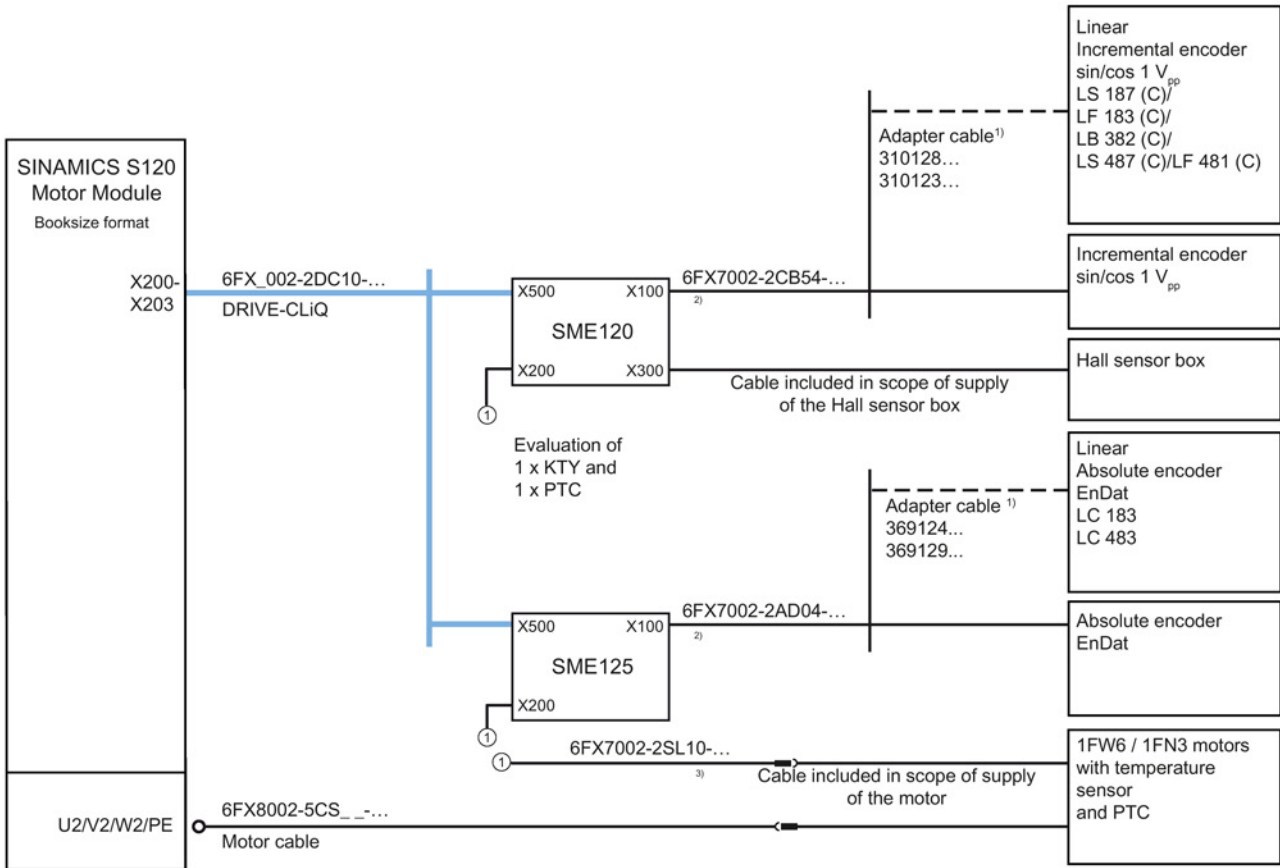

- <sup>1)</sup> Cable can be ordered from the manufacturer of the linear scale
- <sup>2)</sup> Max. encoder cable length, see diagram in Chapter "Technical data"
- <sup>3)</sup> Max. cable length between SME and motor connection: 10 m

Figure 8-39 Connecting motor encoders via SME for motors without a DRIVE-CLiQ interface and molded connecting cables with terminated cable ends

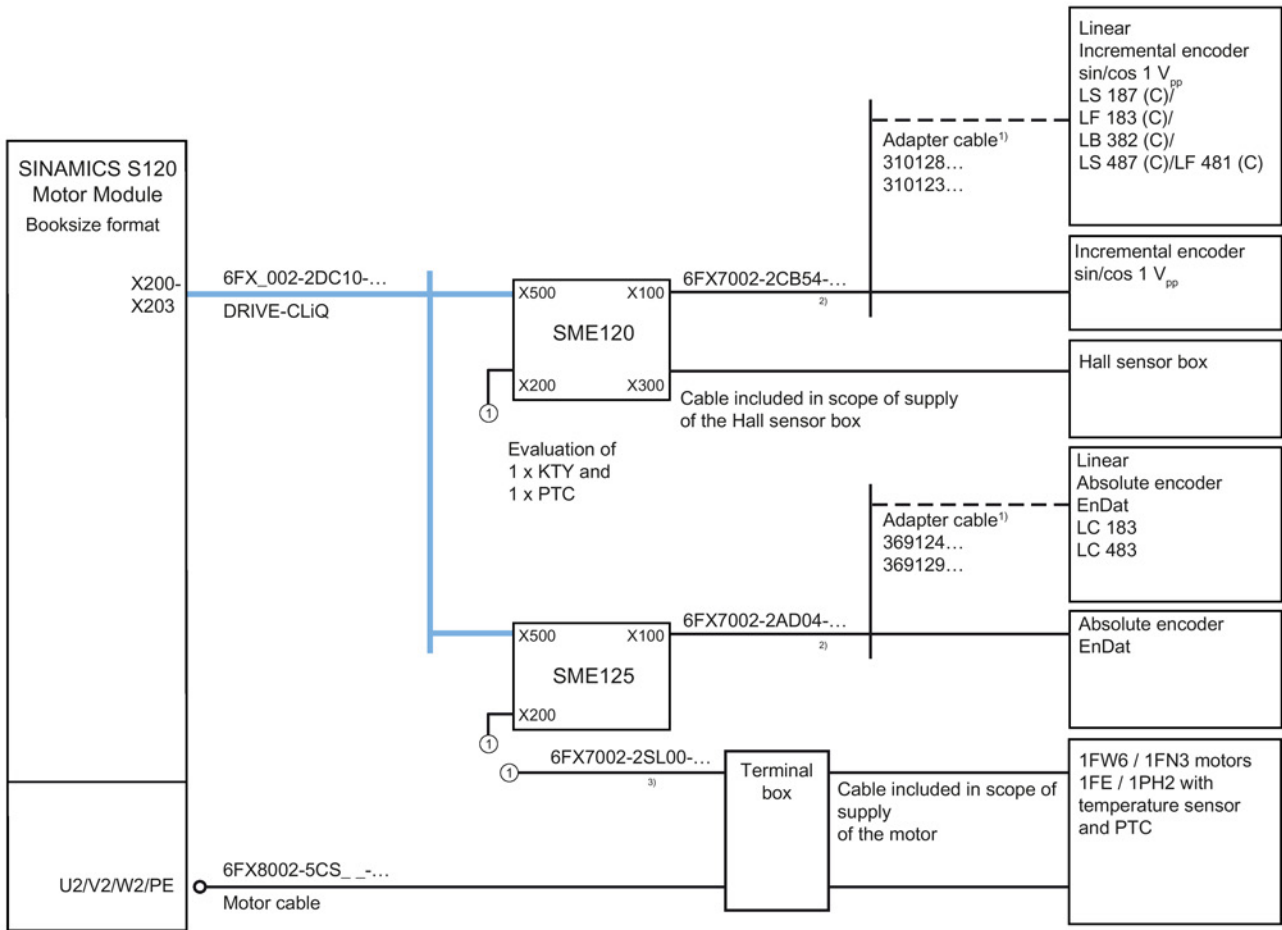

1) Cable can be ordered from the manufacturer of the linear scale  
 2) Max. encoder cable length, see diagram in Chapter "Technical data"  
 3) Max. cable length between SME and motor connection: 10 m

Figure 8-40 Connecting motor encoders via SME for motors without a DRIVE-CLiQ interface and molded connecting cables with open cable ends



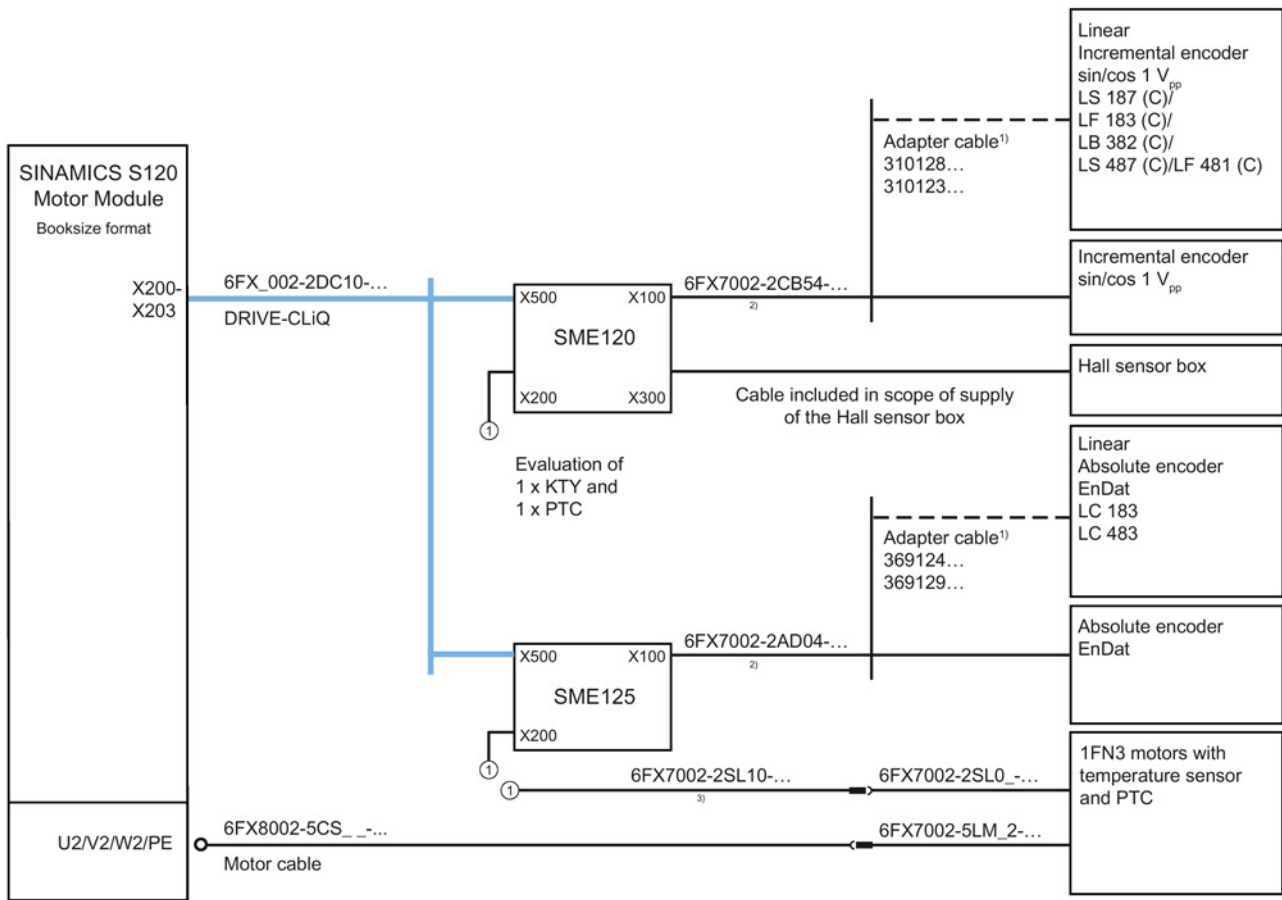
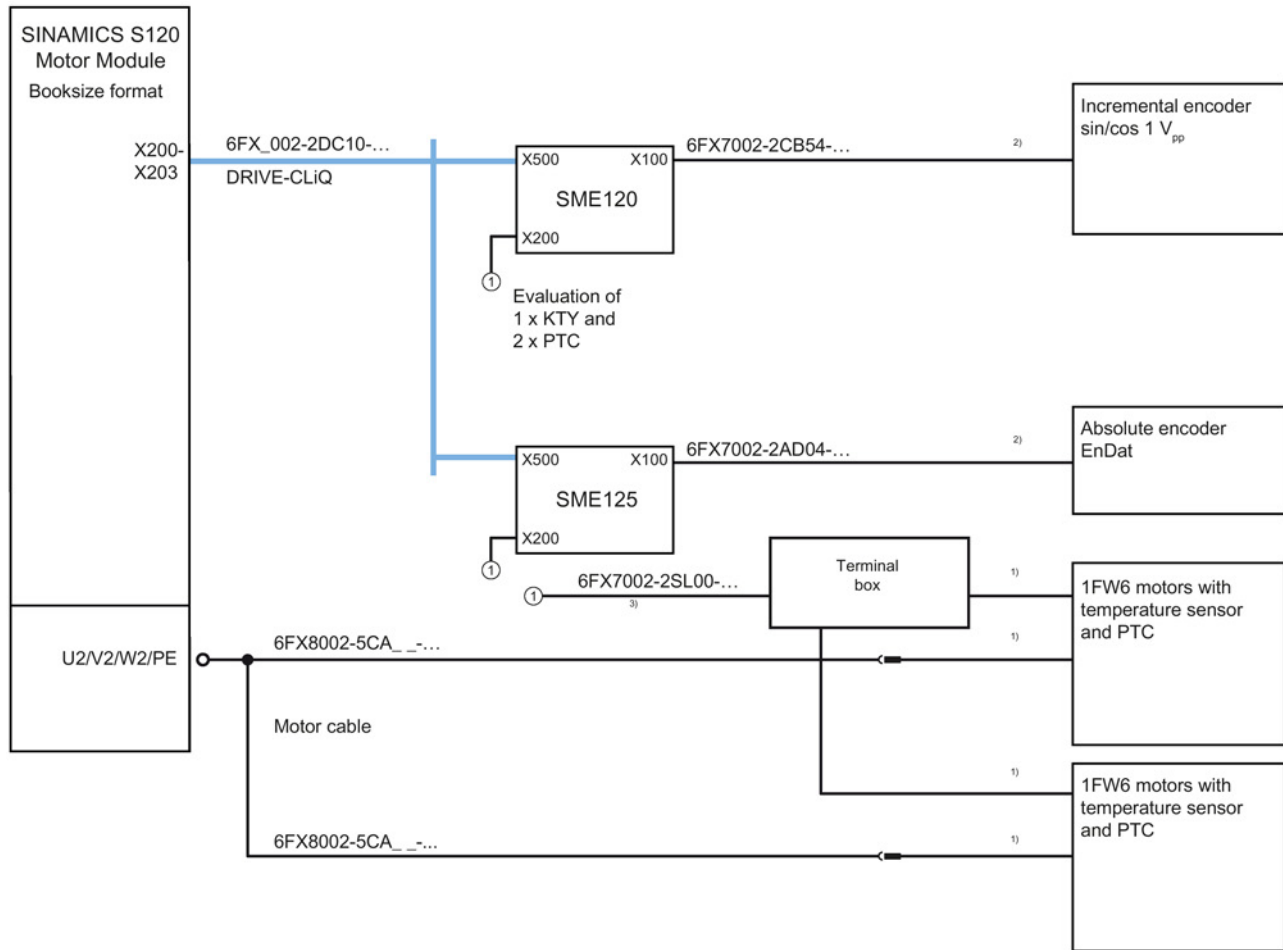

Figure 8-41 Connecting motor encoders via SME for motors without a DRIVE-CLiQ interface, with an integrated 2-hole terminal box

Connection examples for motors connected in parallel



- 1) Cable included in the scope of supply of the motor
- 2) Max. encoder cable length, see diagram in Chapter "Technical data"
- 3) Max. cable length between SME and motor connection: 10 m

Figure 8-42 Connecting motor encoders via SME for torque motors connected in parallel without a DRIVE-CLiQ interface

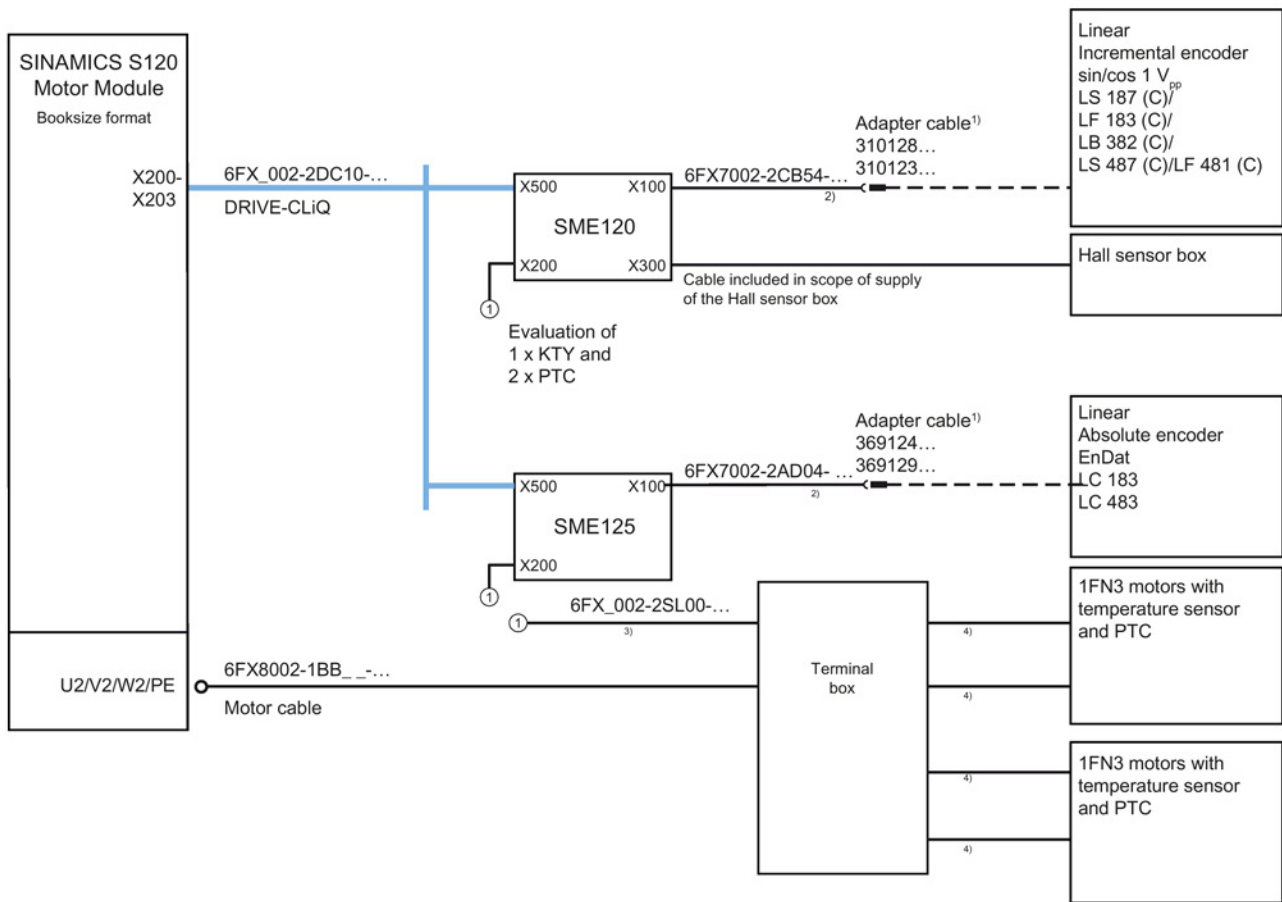

- <sup>1)</sup> Cable can be ordered from the manufacturer of the linear scale
- <sup>2)</sup> Max. encoder cable length, see diagram in Chapter "Technical data"
- <sup>3)</sup> Max. cable length between SME and motor connection: 10 m
- <sup>4)</sup> For motors without terminal box, the cables are included in the scope of supply of the motor. For motors with 2-hole terminal boxes, 6FX7002-2SL0\_... cables must be used.

Figure 8-43 Connecting motor encoders via SME for linear motors connected in parallel without a DRIVE-CLiQ interface

### 8.10.5 Dimension drawing

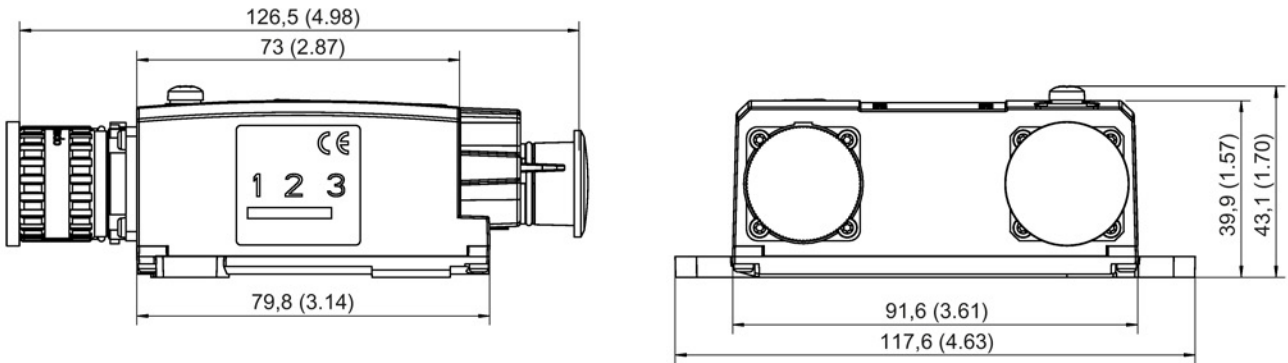
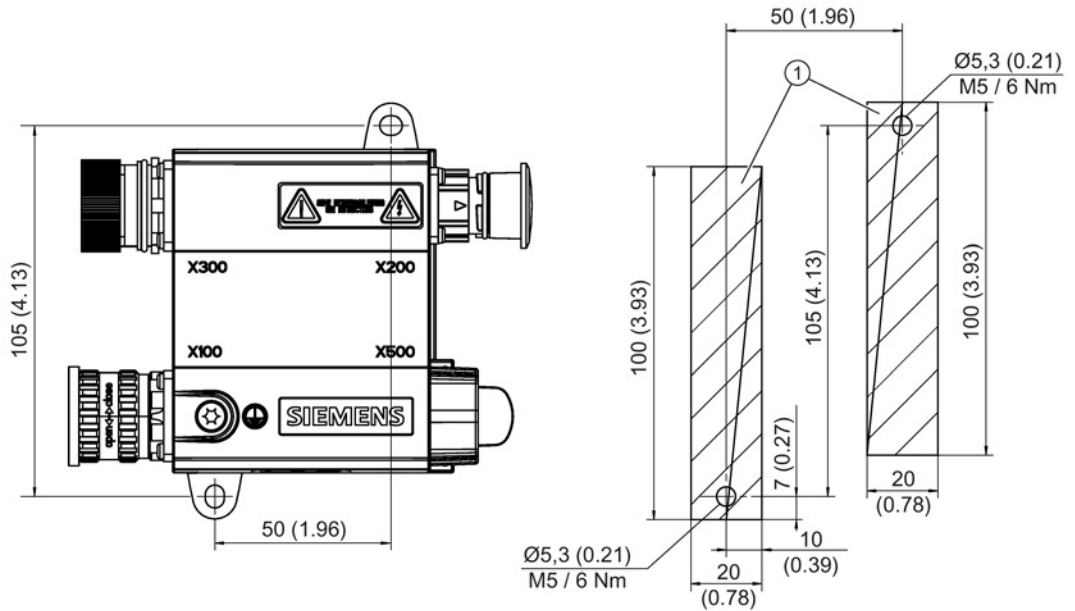

Figure 8-44 Dimension drawing of the Sensor Module External SME120, all data in mm and (inches)

### 8.10.6 Installation



① Contact surface

Figure 8-45 Hole drilling pattern for installation

## Installation

1. Place the drilling pattern on the mounting surface. Make sure that the contact surface is bare, unpainted metal.
2. Drill two holes with  $\varnothing$  5.3 or M5 threaded holes according to the drilling pattern.
3. Fix the Sensor Module to the mounting surface. The tightening torque is 6 Nm.

## 8.10.7 Technical data

Table 8- 37 Technical data

6SL3055-0AA00-5JAx	Unit	Value
<b>Electronics power supply</b>		
Voltage	V <sub>DC</sub>	24 (20.4 ... 28.8)
Current (without encoder system)	A <sub>DC</sub>	≤ 0.20
Current (with encoder system)	A <sub>DC</sub>	≤ 0.30
Power loss	W	≤ 4.5
Max. cable length	m	30
<b>Encoder system power supply</b>		
Voltage	V <sub>DC</sub>	5
Current	A <sub>DC</sub>	0.35
Encoder frequency that can be evaluated (f <sub>encoder</sub> )	kHz	≤ 500
PE/ground connection	At the housing with M4/1.8 Nm screw	
Weight	kg	0.7
Degree of protection		IP67

### Note

#### Current controller clock cycle

For a current controller clock cycle of 31.25  $\mu$ s, an SME120 with article number 6SL3055-0AA00-5JA3 must be used.

### Note

In order to guarantee the degree of protection, all of the plug connectors must be correctly screwed into place and appropriately locked.

The maximum cable length for the encoder system interface depends on the current consumption of the encoder system and the cross-section of the wire in the cable. However, the maximum length is 30 m. The figure below applies to encoder systems that operate in the supply voltage range between 4.75 V and 5.25 V. The sample parameters shown are 0.28 mm<sup>2</sup> cross-section (0.14 mm<sup>2</sup> supply plus 0.14 mm<sup>2</sup> Remote Sense wires) and 0.64 mm<sup>2</sup> (0.5 mm<sup>2</sup> supply plus 0.14 mm<sup>2</sup> Remote Sense wires).

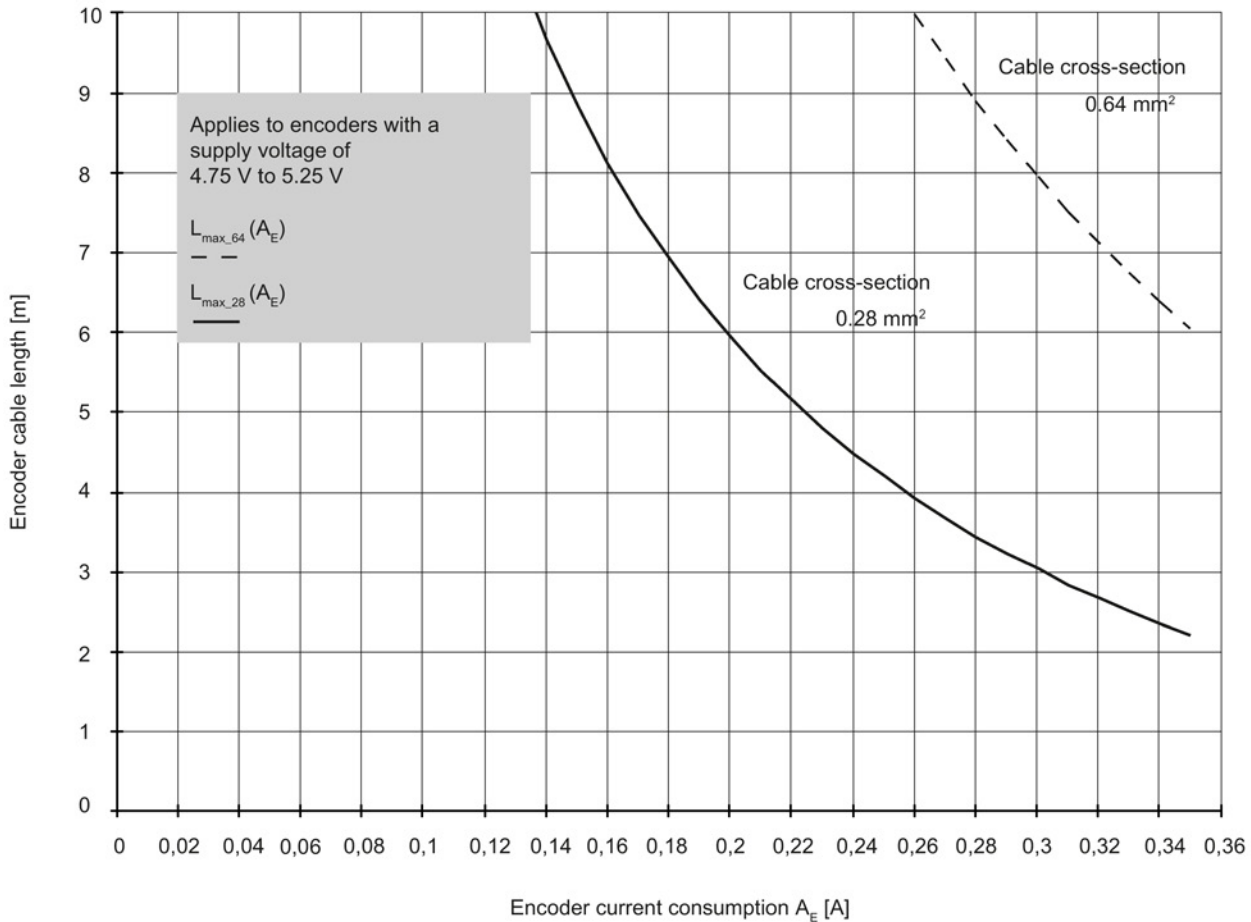

Figure 8-46 Max. cable length as a function of the current drawn by the encoder system

In addition to the encoder systems for the supply voltage range of 4.75 V to 5.25 V in the diagram above, encoder systems are also available for the extended range down to 3.6 V. These are generally operable using encoder system cables up to 30 m in length, provided that the total cross-section of the supply plus Remote Sense wires does not fall below 0.14 mm<sup>2</sup>.

## **8.11 Sensor Module External SME125**

### **8.11.1 Description**

Direct encoder systems outside the cabinet can be connected to the Sensor Module External SME125. The SME125 evaluates these encoder systems and converts the calculated values to DRIVE-CLiQ.

The components are always used when the temperature signals of the motors do not have protective separation or where this separation is not possible for certain reasons. SME125 is mainly used in linear motor applications.

Direct encoder systems with EnDat 2.1, EnDat 2.2 order designation 02 or SSI with SIN/COS (1 Vpp) incremental signals can be connected, however without reference signal.

Neither motor nor encoder data are saved in the SME125.

### 8.11.2 Safety instructions for Sensor Modules External

The following safety instructions specifically apply for Sensor Modules External SME12x.

---

#### Note

When handling/using a Sensor Module External, you must also observe the safety instructions for Sensor Modules as well as the safety instructions in Chapter 1 (Page 19).

---

A Sensor Module External SME12x is a device belonging to safety class I.

 <b>WARNING</b>
<p><b>Death or severe injury can occur when an SME12x is incorrectly used and handled.</b></p> <p>When an SME12x is incorrectly used and handled, protective devices can be disabled; which means that death or severe injury can occur when touching.</p> <ul style="list-style-type: none"><li>• It is mandatory that you connect a protective conductor with a minimum cross-section of 2.5 mm<sup>2</sup> in order to guarantee safe electrical separation.</li><li>• In order to ensure degree of protection IP67, close all connections, even connections that are not used, with connectors or suitable sealing caps. You must observe the specified torques.</li><li>• Before commissioning, always replace the plastic covers of connections X100 to X500 using the corresponding connectors, as otherwise the Sensor Modules External SME12x will not conform with degree of protection IP67.</li><li>• Under no circumstances open the Sensor Modules, as this can mean that they are no longer properly sealed! Only a certified SIEMENS service center should carry out repair and maintenance work.</li><li>• If it appears that the Sensor Module packaging has been damaged by water, do not commission the Sensor Module.</li></ul>

<b>NOTICE</b>
<p><b>Damage caused by connecting a grounded encoder system power supply</b></p> <p>The devices can be damaged by connecting encoder systems with grounded encoder system power supplies.</p> <ul style="list-style-type: none"><li>• Only connect those encoder systems where the power supply is <b>not</b> grounded.</li></ul>



## 8.11.3 Interface description

### 8.11.3.1 Overview

Protective conductor connection  
M4 screw  
Tightening torque, 1.8 Nm  
Cross-section min. 2.5 mm<sup>2</sup>

X100  
Encoder system interface  
Tightening torque, 3.5 Nm

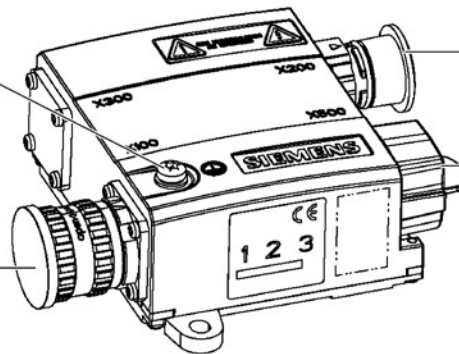

X200  
Temperature sensor input  
Tightening torque, 2 Nm

X500  
DRIVE-CLiQ interface

Figure 8-47 Interface description, SME125

8.11.3.2 X100 encoder system interface

Table 8- 38 X100: Encoder system interface

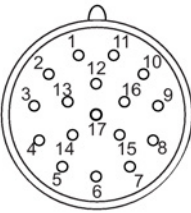
	Pin	Signal name	Technical data
	1	P5	Encoder power supply
	2	Reserved, do not use	
	3	Reserved, do not use	
	4	M	Ground, encoder power supply
	5	Reserved, do not use	
	6	Reserved, do not use	
	7	P5	Encoder power supply
	8	Clock	Clock, EnDat interface, SSI clock
	9	Clock*	Inverted clock, EnDat interface, inverted SSI clock
	10	M	Ground, encoder power supply
	11	Housing potential	
	12	B	Incremental signal B
	13	B*	Inverse incremental signal B
	14	Data	Data, EnDat interface, SSI data
	15	A	Incremental signal A
	16	A*	Inverse incremental signal A
	17	Data*	Inverse data, EnDat interface, Inverse SSI data
Connector kit:	17 pole, article number: 6FX2003-0SA17		
Blanking plate for encoder system interface: Company Pöppelmann GmbH & Co. KG, Lohne, Article number: GPN 300 F211			

## 8.11.3.3 X200 thermistor sensor input

Table 8- 39 X200: Temperature sensor input

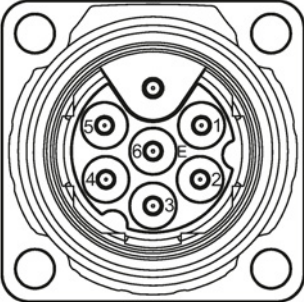
	Pin	Function	Technical data
	1	-Temp	Temperature sensor connection KTY84-1C130/PTC/bimetallic switch with NC contact In linear and torque motor applications, connect the KTY84-1C130 motor temperature sensor here
	2	+Temp	
	3	+Temp	Temperature sensor connection KTY84-1C130/PTC/bimetallic switch with NC contact In linear and torque motor applications, connect the PTC triple element 1 or bimetallic switch here
	4	-Temp	
	5	+Temp	Temperature sensor connection KTY84-1C130/PTC/bimetallic switch with NC contact In torque motor applications, connect the PTC triple element 2 here
	6	-Temp	
Connector kit:	6+1-pole, article number: 6FX2003-0SU07		
Measuring current via temperature sensor connection: 2 mA			
Accuracy of temperature measurement: - KTY: $\pm 7$ °C (incl. evaluation) - PTC: $\pm 5$ °C (incl. evaluation)			

**NOTICE****Overheating of the motor through jumpering the temperature sensor connections**

Jumpering of the temperature sensor connections "+ Temp" and "- Temp" results in incorrect measurement results. Damage to the motor can result if the overheating is not detected.

- When using several temperature sensors, separately connect the individual sensors to "+ Temp" and "- Temp".

## 8.11.3.4 X500 DRIVE-CLiQ interface

Table 8- 40 X500: DRIVE-CLiQ interface

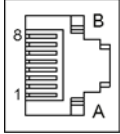
	Pin	Signal name	Technical data
	1	TXP	Transmit data +
	2	TXN	Transmit data -
	3	RXP	Receive data +
	4	Reserved, do not use	
	5	Reserved, do not use	
	6	RXN	Receive data -
	7	Reserved, do not use	
	8	Reserved, do not use	
	A	+ (24 V)	Power supply
	B	M (0 V)	Electronics ground
	Connector type	DRIVE-CLiQ socket	
Power consumption max. 0.30 A			

The blanking cover for the DRIVE-CLiQ port to secure the degree of protection IP 67 is not included in the scope of delivery.

Blanking covers (6 units), article number: 6SL3066-4CA01-0AA0

**Note**

Only MOTION-CONNECT DRIVE-CLiQ cables may be used for connections. The maximum cable length is 100 m for MOTION-CONNECT 500, and 75 m for MOTION-CONNECT 800PLUS cables.

### 8.11.4 Connection examples

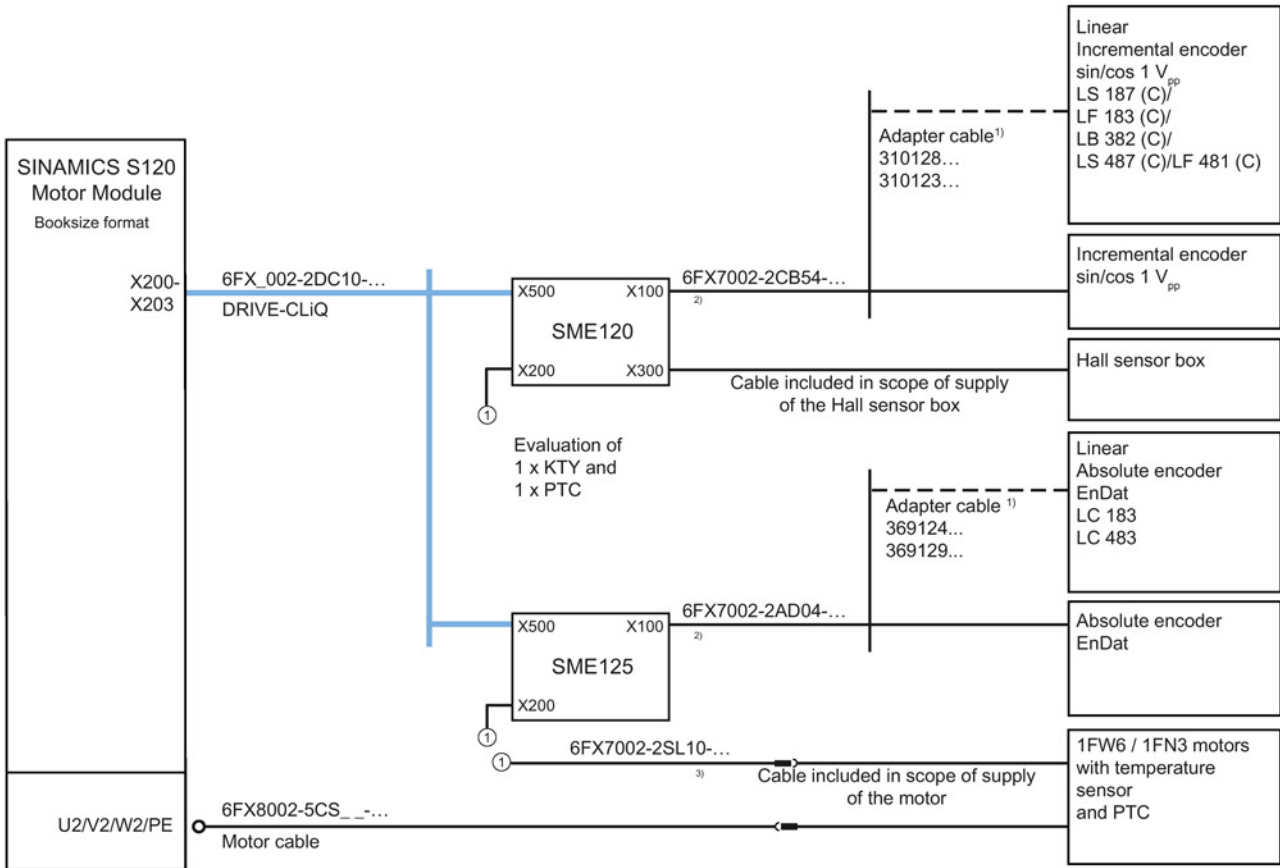

- <sup>1)</sup> Cable can be ordered from the manufacturer of the linear scale
- <sup>2)</sup> Max. encoder cable length, see diagram in Chapter "Technical data"
- <sup>3)</sup> Max. cable length between SME and motor connection: 10 m

Figure 8-48 Connecting motor encoders via SME for motors without a DRIVE-CLiQ interface and molded connecting cables with terminated cable ends

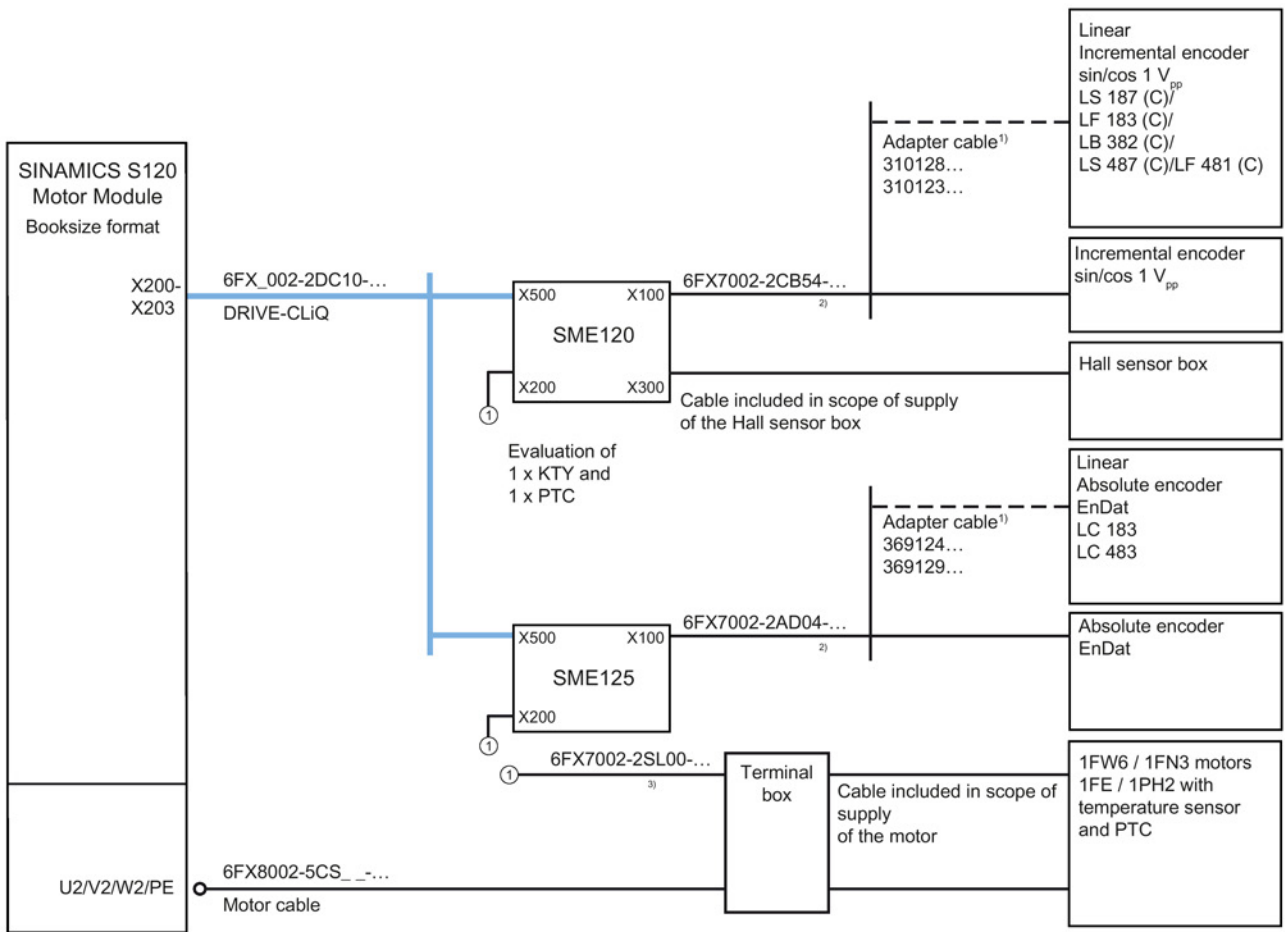

1) Cable can be ordered from the manufacturer of the linear scale  
 2) Max. encoder cable length, see diagram in Chapter "Technical data"  
 3) Max. cable length between SME and motor connection: 10 m

Figure 8-49 Connecting motor encoders via SME for motors without a DRIVE-CLiQ interface and molded connecting cables with open cable ends

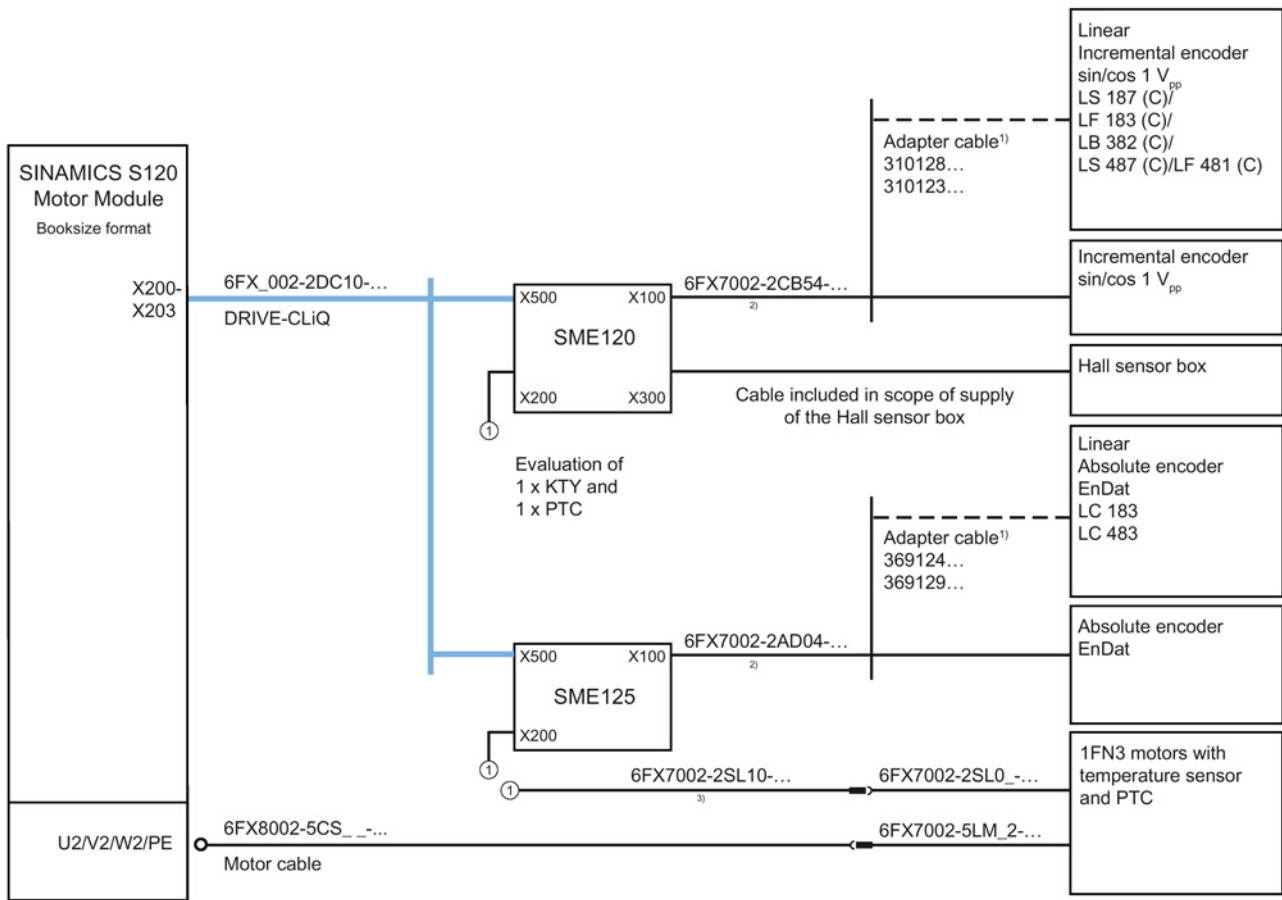

- <sup>1)</sup> Cable can be ordered from the manufacturer of the linear scale  
<sup>2)</sup> Max. encoder cable length, see diagram in Chapter "Technical data"  
<sup>3)</sup> Max. cable length between SME and motor connection: 10 m

Figure 8-50 Connecting motor encoders via SME for motors without a DRIVE-CLiQ interface, with an integrated 2-hole terminal box

Connection examples for motors connected in parallel

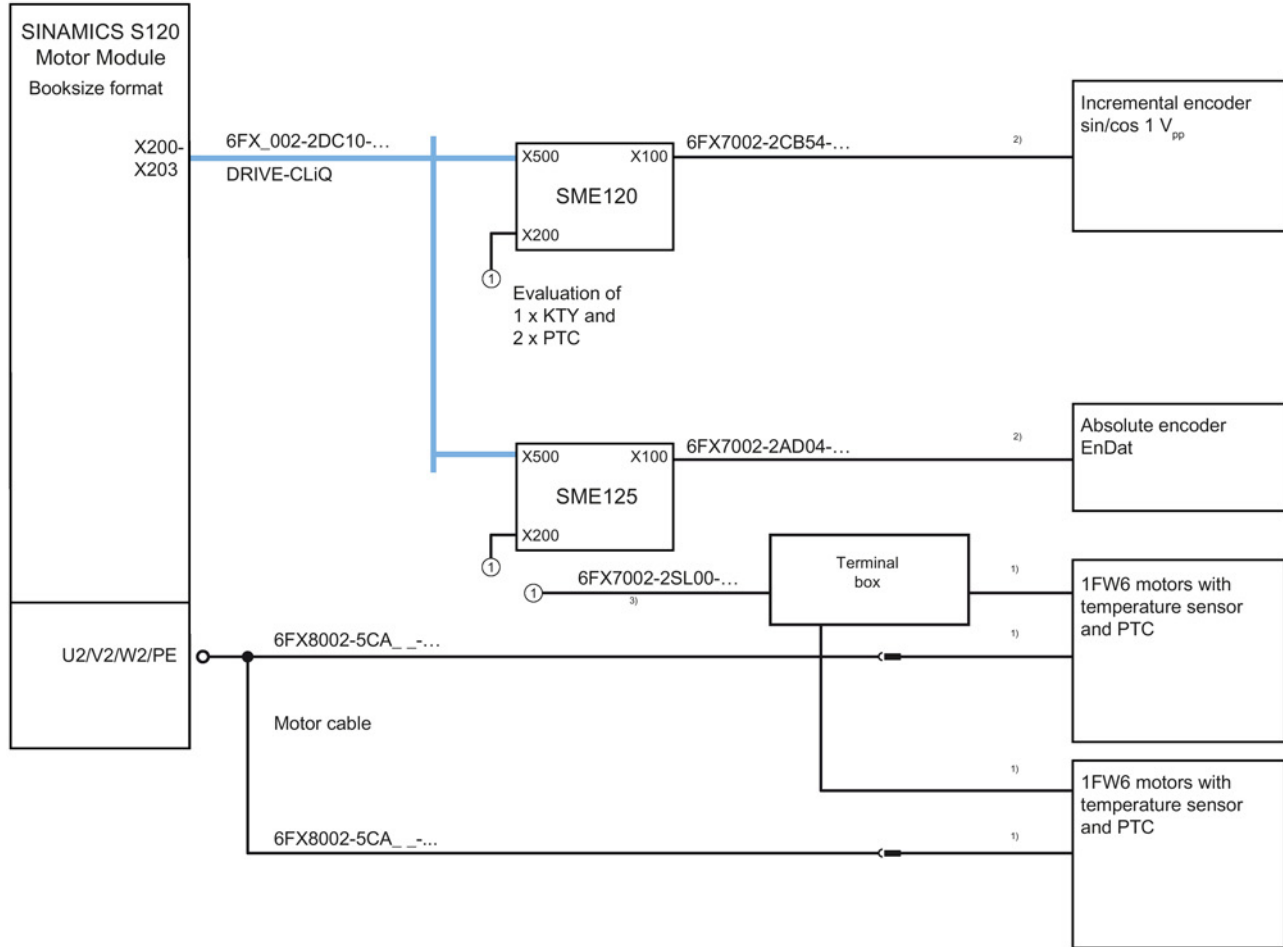

- 1) Cable included in the scope of supply of the motor
- 2) Max. encoder cable length, see diagram in Chapter "Technical data"
- 3) Max. cable length between SME and motor connection: 10 m

Figure 8-51 Connecting motor encoders via SME for torque motors connected in parallel without a DRIVE-CLiQ interface



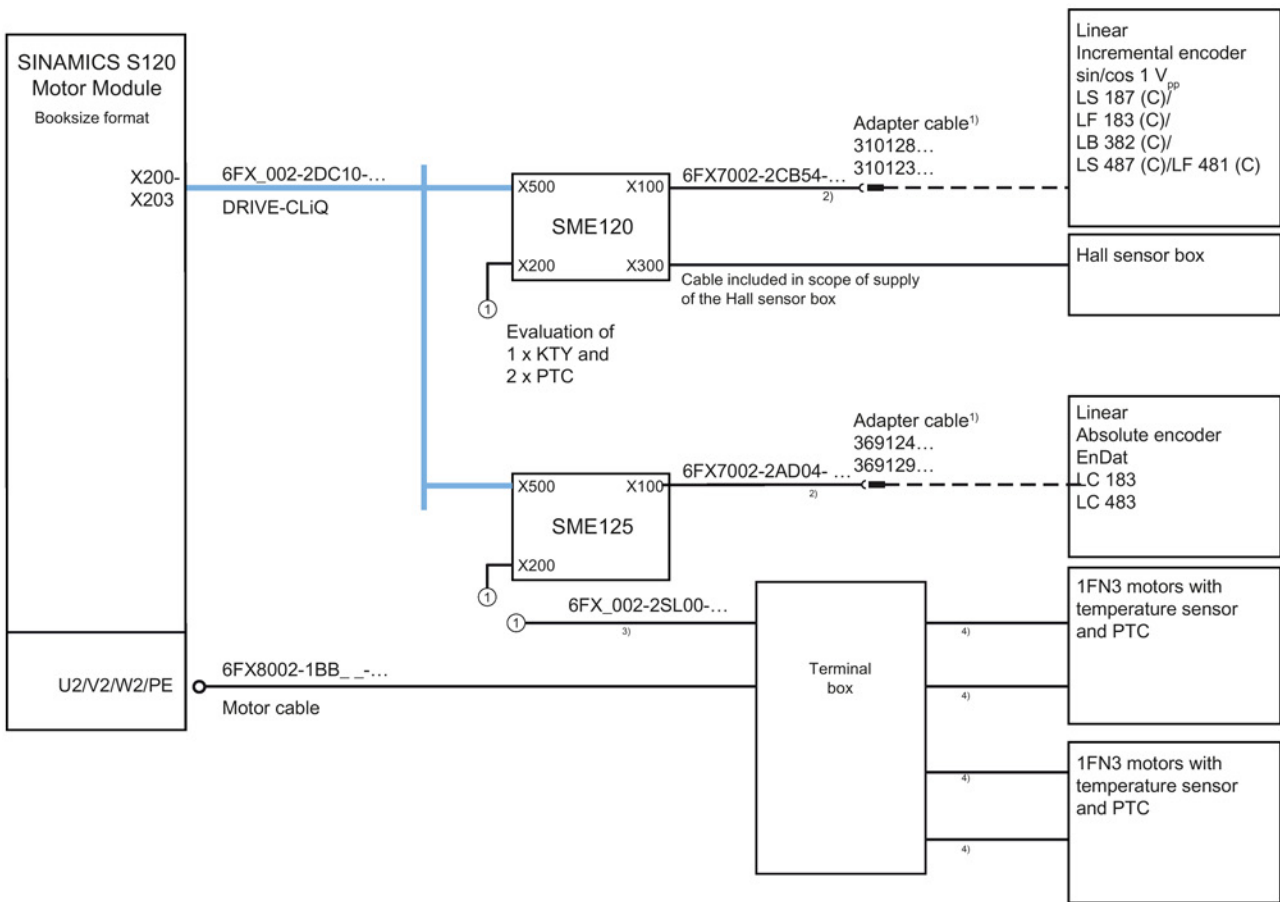

Figure 8-52 Connecting motor encoders via SME for linear motors connected in parallel without a DRIVE-CLiQ interface

### 8.11.5 Dimension drawing

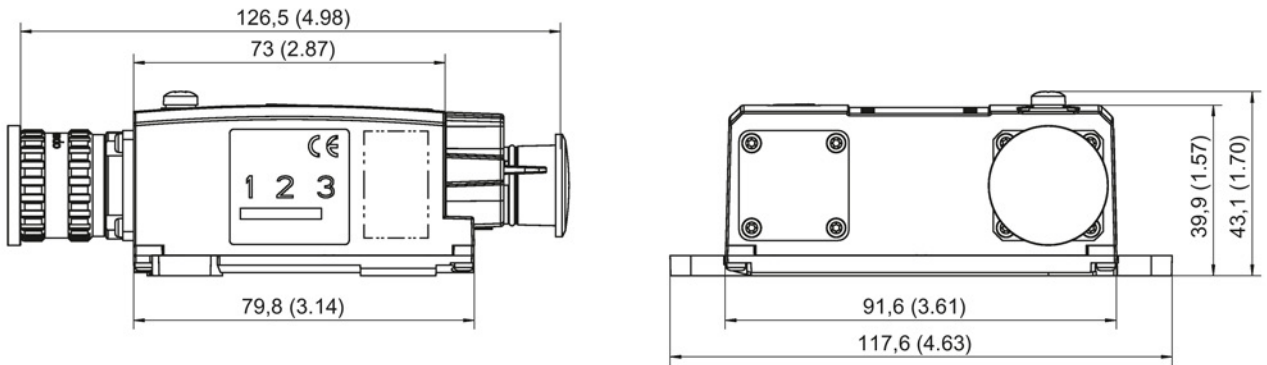
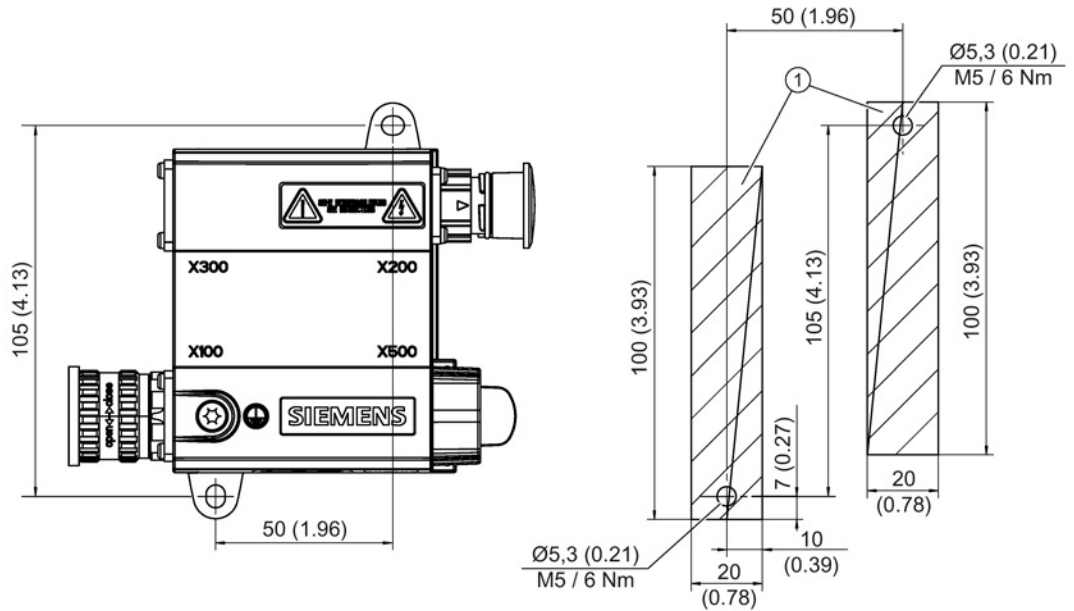

Figure 8-53 Dimension drawing of the Sensor Module External SME125, all data in mm and (inches)

### 8.11.6 Installation



① Contact surface

Figure 8-54 Hole drilling pattern for installation

## Installation

1. Place the drilling pattern on the mounting surface. Make sure that the contact surface is bare, unpainted metal.
2. Drill two holes with  $\varnothing$  5.3 or M5 threaded holes according to the drilling pattern.
3. Fix the Sensor Module to the mounting surface. The tightening torque is 6 Nm.

### 8.11.7 Technical data

Table 8- 41 Technical data

6SL3055-0AA00-5KAx	Unit	Value
Electronics power supply		
Voltage	V <sub>DC</sub>	24 (20.4 ... 28.8)
Current (without encoder system)	A <sub>DC</sub>	≤ 0.20
Current (with encoder system)	A <sub>DC</sub>	≤ 0.30
Power loss	W	≤ 4.5
Max. cable length	m	30
Encoder system power supply		
Voltage	V <sub>DC</sub>	5
Current	A <sub>DC</sub>	0.35
Encoder frequency that can be evaluated (f <sub>encoder</sub> )	kHz	≤ 500
SSI/EnDat baud rate	kBd	100
PE/ground connection	At the housing with M4 screw Tightening torque: 1.8 Nm	
Weight	kg	0.7
Degree of protection		IP67

#### Note

##### Current controller clock cycle

For a current controller clock cycle of 31.25  $\mu$ s, an SME125 with article number 6SL3055-0AA00-5KA3 must be used.

#### Note

In order to guarantee the degree of protection, all of the plug connectors must be correctly screwed into place and appropriately locked.

The maximum cable length for the encoder system interface depends on the current consumption of the encoder system and the cross-section of the wire in the cable. However, the maximum length is 30 m. The figure below applies to encoder systems that operate in the supply voltage range between 4.75 V and 5.25 V. The sample parameters shown are 0.28 mm<sup>2</sup> cross-section (0.14 mm<sup>2</sup> supply plus 0.14 mm<sup>2</sup> Remote Sense wires) and 0.64 mm<sup>2</sup> (0.5 mm<sup>2</sup> supply plus 0.14 mm<sup>2</sup> Remote Sense wires).

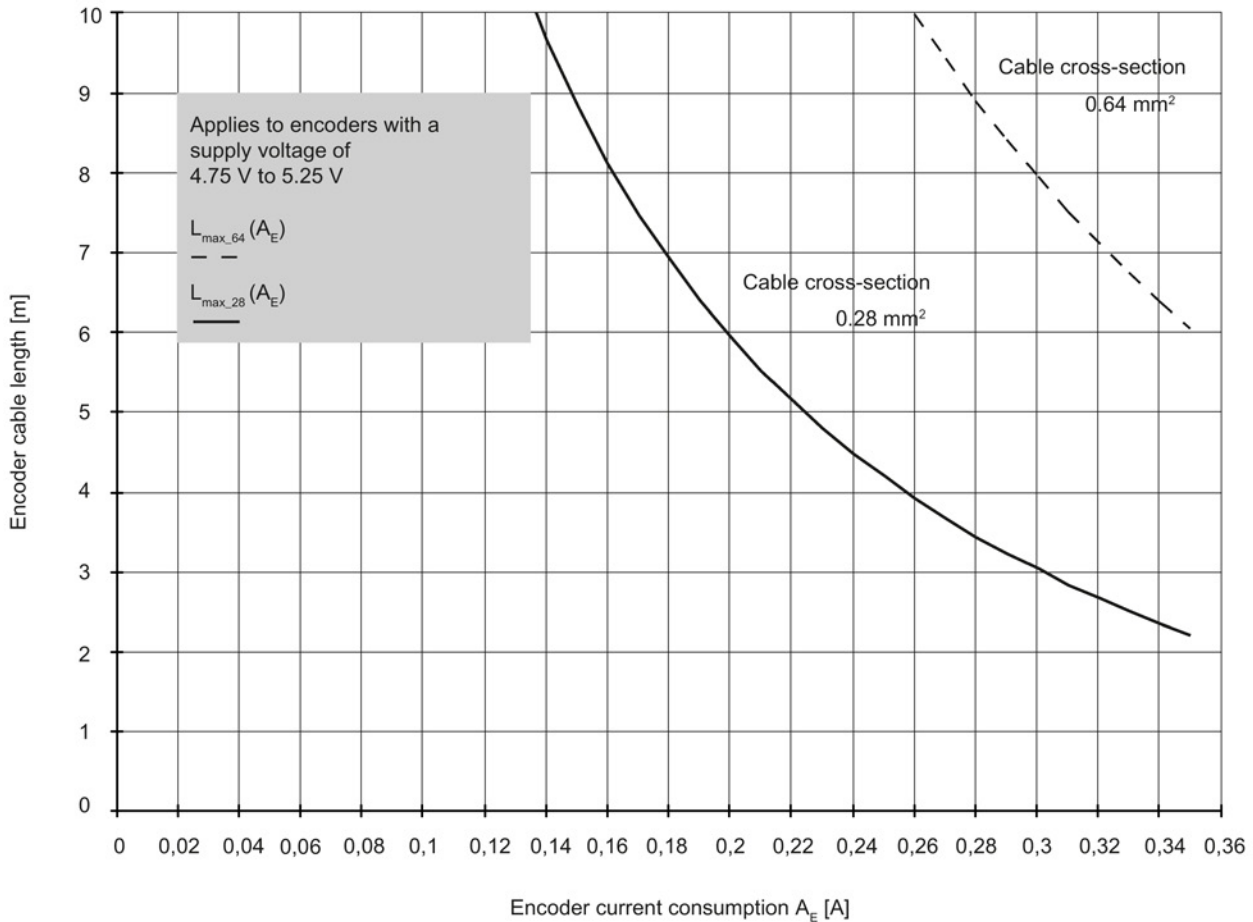

Figure 8-55 Max. cable length as a function of the current drawn by the encoder system

In addition to the encoder systems for the supply voltage range of 4.75 V to 5.25 V in the diagram above, encoder systems are also available for the extended range down to 3.6 V. These are generally operable using encoder system cables up to 30 m in length, provided that the total cross-section of the supply plus Remote Sense wires does not fall below 0.14 mm<sup>2</sup>.

## 8.12 DRIVE-CLiQ encoder

### 8.12.1 Description

The DRIVE-CLiQ encoder is available as an absolute encoder with integrated DRIVE-CLiQ interface. The multiturn design of the encoder senses absolute position values extending over 4096 revolutions. The singleturn design senses the absolute position within a revolution.

The most important advantages are:

- Automatic commissioning via DRIVE-CLiQ
- High operating temperatures of 100 °C are possible
- Integrated diagnostics concept

Table 8- 42 Encoder for mounting with DRIVE-CLiQ

Designation	Article No.	Description
DRIVE-CLiQ synchronous flange VW 6 mm	6FX2001-5FD13-0AAx	Absolute encoder with DRIVE-CLiQ, single-turn
DRIVE-CLiQ clamping flange VW 10 mm	6FX2001-5QD13-0AAx	Absolute encoder with DRIVE-CLiQ, single-turn
DRIVE-CLiQ hollow shaft 10 mm	6FX2001-5VD13-0AAx	Absolute encoder with DRIVE-CLiQ, single-turn
DRIVE-CLiQ hollow shaft 12 mm	6FX2001-5WD13-0AAx	Absolute encoder with DRIVE-CLiQ, single-turn
DRIVE-CLiQ synchronous flange VW 6 mm	6FX2001-5FD25-0AAx	Absolute encoder with DRIVE-CLiQ, multiturn
DRIVE-CLiQ clamping flange VW 10 mm	6FX2001-5QD25-0AAx	Absolute encoder with DRIVE-CLiQ, multiturn
DRIVE-CLiQ hollow shaft 10 mm	6FX2001-5VD25-0AAx	Absolute encoder with DRIVE-CLiQ, multiturn
DRIVE-CLiQ hollow shaft 12 mm	6FX2001-5WD25-0AAx	Absolute encoder with DRIVE-CLiQ, multiturn

### 8.12.2 Interface description

#### 8.12.2.1 Overview



Figure 8-56 DRIVE-CLiQ encoder

### 8.12.2.2 DRIVE-CLiQ interface

Table 8- 43 DRIVE-CLiQ interface

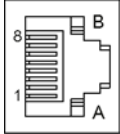
	Pin	Signal name	Technical data
	1	TXP	Transmit data +
	2	TXN	Transmit data -
	3	RXP	Receive data +
	4	Reserved, do not use	
	5	Reserved, do not use	
	6	RXN	Receive data -
	7	Reserved, do not use	
	8	Reserved, do not use	
	A	Reserved, do not use	
	B	M (0 V)	Electronics ground

The blanking cover for the DRIVE-CLiQ port to secure the degree of protection IP 67 is not included in the scope of delivery.

Blanking covers (6 units), article number: 6SL3066-4CA01-0AA0

### 8.12.3 Dimension drawings

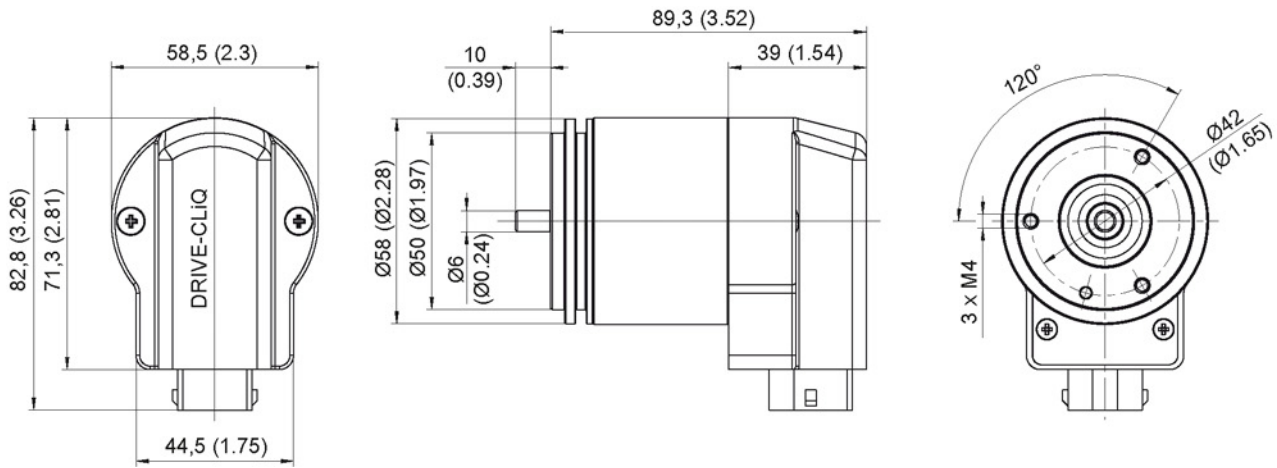

Figure 8-57 Dimension drawing of synchronous flange, all data in mm and (inches)

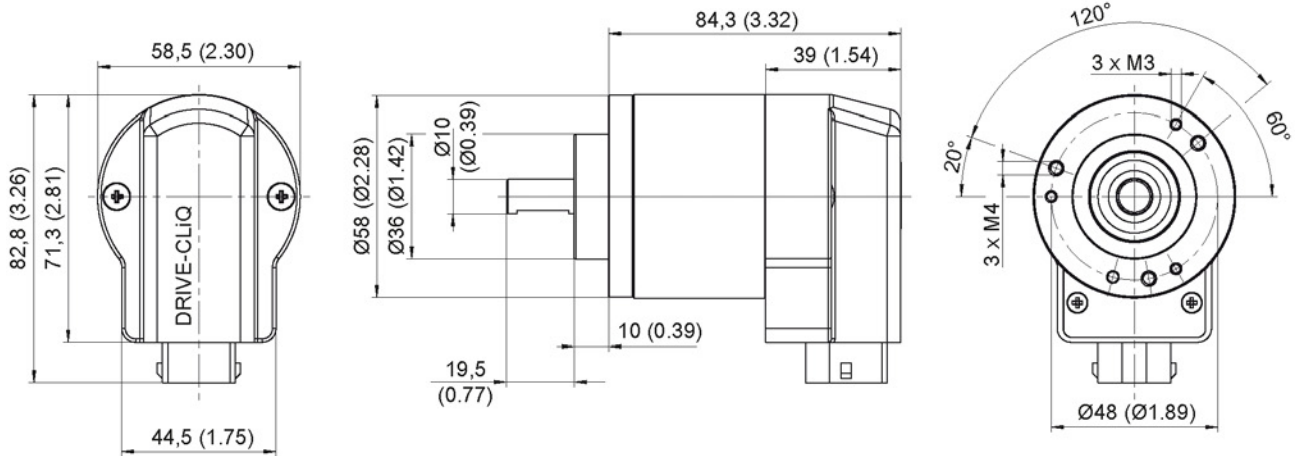

Figure 8-58 Dimension drawing of clamping flange, all data in mm and (inches)

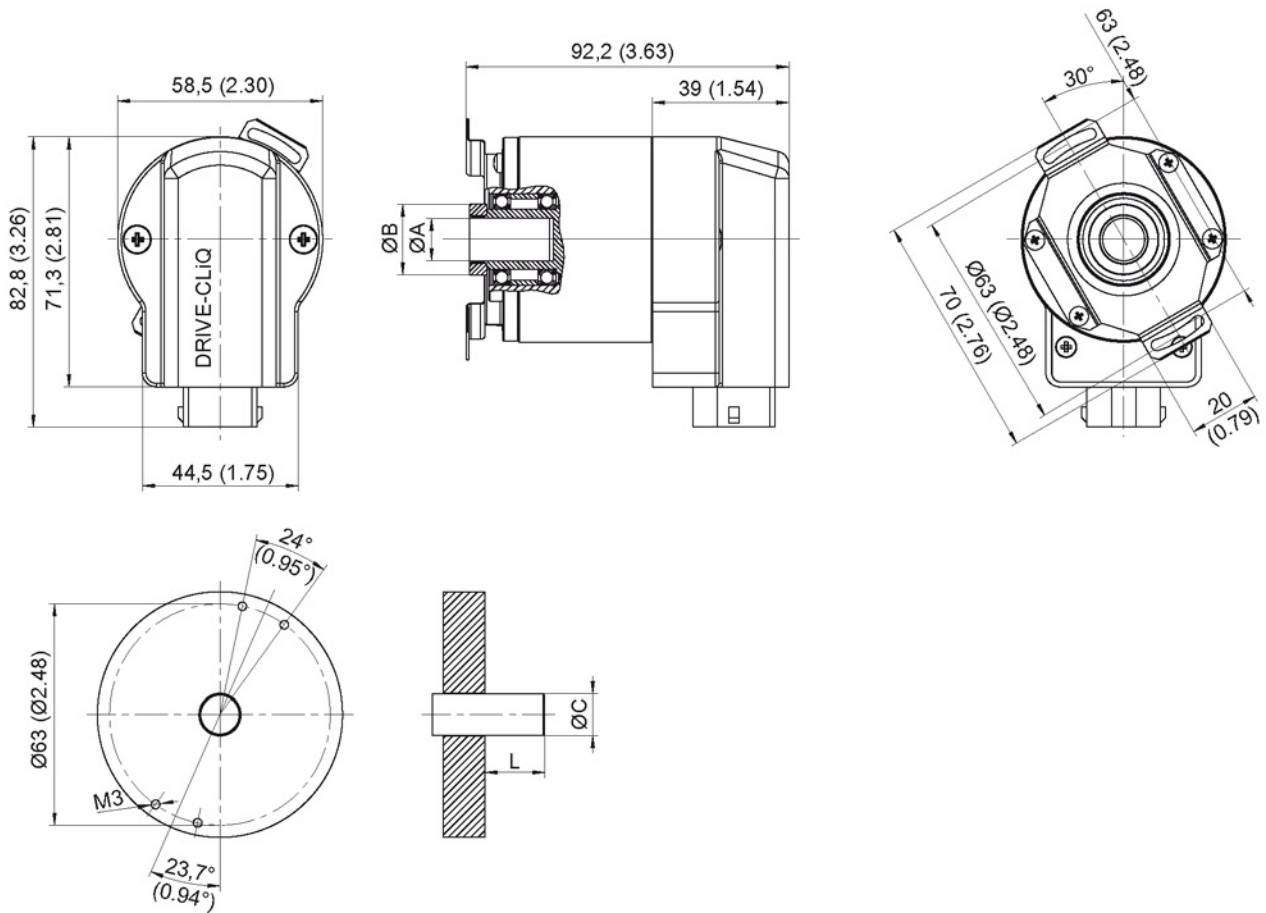

Figure 8-59 Dimension drawing of hollow shaft, all data in mm and (inches)

Table 8- 44 Dimensions

	Dimensions		Unit
Hollow shaft ØA	10 <sup>+0.012</sup> (0.39)	12 <sup>+0.012</sup> (0.47)	mm (inch)
Connection shafts ØC	10 (0.39)	12 (0.47)	mm (inch)
Clamping ring ØB	18 (0.70)	20 (0.78)	mm (inch)
L min.	15 (0.59)	18 (0.70)	mm (inch)
L max.	20 (0.78)	20 (0.78)	mm (inch)
Shaft code	2 (0.07)	7 (0.27)	mm (inch)

L = Engaged depth of the connection shaft into the encoder

### 8.12.4 Installation

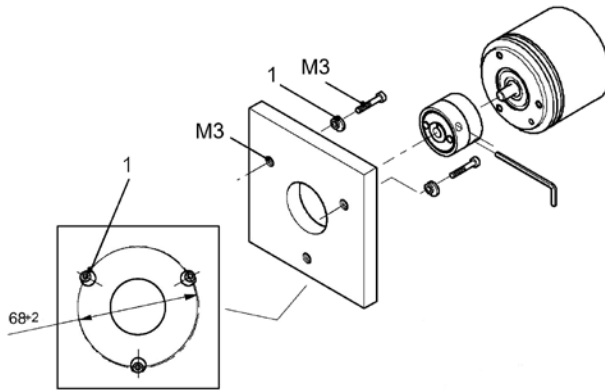

Figure 8-60 Installation: Synchronous flange, 1: Clamp straps



## Clamp straps / couplings

Clamp straps and couplings are required as mounting accessories. The clamp straps are used to fix the encoders with a synchronous flange.

Table 8- 45 Selection and ordering data

Designation	Article No.
Clamp strap (No.1 in the drawing) for encoder with synchronous flange (3 units are required)	6FX2001-7KP01
Spring disk coupling Shaft diameter: <ul style="list-style-type: none"> <li>• 6 mm / 6 mm</li> <li>• 6 mm / 5 mm</li> </ul>	6FX2001-7KF10 6FX2001-7KF06
Plug-in coupling Shaft diameter: <ul style="list-style-type: none"> <li>• 6 mm / 6 mm</li> <li>• 10 mm / 10 mm</li> </ul>	6FX2001-7KS06 6FX2001-7KS10

Table 8- 46 Installation instructions

Product name	Spring disk coupling	Plug-in coupling
Transmission torque, max.	0.8 Nm	0.7 Nm
Shaft diameter	6 mm both ends or $d_1 = 6 \text{ mm}$ , $d_2 = 5 \text{ mm}$	6 mm both ends or 10 mm both ends
Center offset of shafts, max.	0.4 mm	0.5 mm
Axial offset	$\pm 0.4 \text{ mm}$	$\pm 0.5 \text{ mm}$
Angular displacement of shafts, max.	3°	1°
Torsional rigidity	150 Nm / rad	31 Nm / rad
Lateral spring stiffness	6 N / mm	10 N / mm
Moment of inertia	19 gcm <sup>2</sup>	20 gcm <sup>2</sup>
Max. speed	12000 rpm	12000 rpm
Operating temperature	-20 ... +150 °C	-20 ... +80 °C
Weight, approx.	16 g	20 g

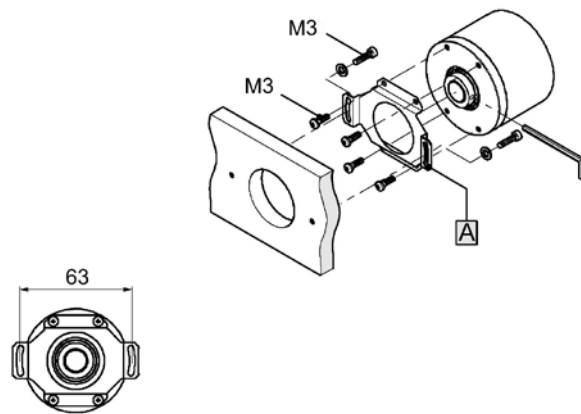

Figure 8-61 Installation: Hollow shaft, A: Spring plate (included in scope of supply)

## 8.12.5 Technical data

Table 8- 47 Technical data of DRIVE-CLiQ encoders

Design	Unit	Absolute encoder with DRIVE-CLiQ
<b>Operating voltage</b> at encoder	V	24 V -15% / +20%
<b>Power consumption</b> Single-turn Multiturn	mA mA	Approx. 245 Approx. 325
<b>Interface</b>		DRIVE-CLiQ
<b>Speed</b> electrically permissible mechanical, max.	rpm rpm	14000 10000
<b>Cable length</b> , max.	m	100
<b>Connection</b>		DRIVE-CLiQ connector, radial
<b>Resolution</b> Single-turn Multiturn	Bit Bit	22 34 (22 bit single-turn + 12 bit multiturn)
<b>Accuracy</b>	Angular seconds	±35
<b>Frictional torque</b>	Nm	≤ 0.01 (at 20°C)
<b>Starting torque</b>	Nm	≤ 0.01 (at 20°C)
<b>Shaft load capability</b> d 10 x 19.5 70° n > 6000 rpm n ≤ 6000 rpm		axial 40 N / radial 40 N at the shaft end axial 40 N / radial 60 N at the shaft end
<b>Angular acceleration</b> , max.	rad/s <sup>2</sup>	10 <sup>5</sup>
<b>Moment of inertia of the rotor</b> Solid shaft Hollow shaft	kgm <sup>2</sup> kgm <sup>2</sup>	1.90 * 10 <sup>-6</sup> kgm <sup>2</sup> 2.80 * 10 <sup>-6</sup> kgm <sup>2</sup>
<b>Vibratory load</b>	m/s <sup>2</sup>	≤ 100 (10 - 500 Hz)
<b>Shock</b> (6 ms)	m/s <sup>2</sup>	≤ 1000 (6 ms)
<b>Operating temperature</b> min. max.	°C °C	-20 100
<b>Degree of protection</b>		IP67 at the frame IP64 at the shaft input
<b>Weight</b> Single-turn Multiturn	kg kg	0.40 0.44



## 9.1 Tightening torques for screws and screw connections

For screws and screw connections of components that are described in this manual, the following tightening torques apply:

Table 9- 1 Tightening torques for ground connections, protective conductor screw connections and control cabinet installation

Thread	Tightening torque in Nm
M3	0.8 Nm
M4	1.8 Nm
M5	3.0 Nm
M6	6.0 Nm
M8	13.0 Nm
M10	25.0 Nm

Tolerance → 0 to +30 %

### Deviating tightening torques

For screw terminals on components and for mounting individual components in the control cabinet, the following deviating tightening torques apply. The corresponding data are described in the following chapters:

- Installation for SME20 (Page 281), SME25 (Page 287), SME120 (Page 300) and SME125 (Page 314)
- Screw terminals (Page 336)

## **9.2 Information on control cabinet installation and EMC**

Information on control cabinet installation and electromagnetic compatibility (EMC), as well as on overcurrent and overvoltage protection, can be found in the following manuals:

- Components in the booksize format:  
SINAMICS S120 Manual for Booksize Power Units
- Components in the blocksize format:  
SINAMICS S120 Manual AC Drive
- Components in the chassis format:  
SINAMICS S120 Manual for Chassis Power Units
- SINAMICS S120 Manual Liquid Cooled Chassis Power Units

The requirements to implement EMC are listed in the Configuration Manual "EMC installation guideline" (Article number 6FC5297-0AD30-0xPx).

# Appendix

## A.1 List of abbreviations

---

### Note

The following list of abbreviations includes all abbreviations and their meanings used in the entire SINAMICS family of drives.

---

Abbreviation	Source of the abbreviation	Meaning
<b>A</b>		
A...	Alarm	Alarm
AC	Alternating Current	Alternating current
ADC	Analog Digital Converter	Analog-digital converter
AI	Analog Input	Analog input
AIM	Active Interface Module	Active Interface Module
ALM	Active Line Module	Active Line Module
AO	Analog Output	Analog output
AOP	Advanced Operator Panel	Advanced Operator Panel
APC	Advanced Positioning Control	Advanced Positioning Control
AR	Automatic Restart	Automatic restart
ASC	Armature Short-Circuit	Armature short-circuit
ASCII	American Standard Code for Information Interchange	American standard code for information interchange
AS-i	AS-Interface (Actuator Sensor Interface)	AS interface (open bus system in automation technology)
ASM	Asynchronmotor	Induction motor
<b>B</b>		
BB	Betriebsbedingung	Operating condition
BERO	-	Proximity switch
BI	Binector Input	Binector Input
BIA	Berufsgenossenschaftliches Institut für Arbeitssicherheit	BG Institute for Occupational Safety and Health
BICO	Binector Connector Technology	Binector connector technology
BLM	Basic Line Module	Basic Line Module

<b>Abbreviation</b>	<b>Source of the abbreviation</b>	<b>Meaning</b>
BO	Binector Output	Binector output
BOP	Basic Operator Panel	Basic Operator Panel
<b>C</b>		
C	Capacitance	Capacitance
C...	-	Safety message
CAN	Controller Area Network	Serial bus system
CBC	Communication Board CAN	Communication Board CAN
CBE	Communication Board Ethernet	PROFINET communication module (Ethernet)
CD	Compact Disc	Compact disk
CDS	Command Data Set	Command data set
CF Card	CompactFlash Card	CompactFlash card
CI	Connector Input	Connector Input
CLC	Clearance Control	Clearance control
CNC	Computer Numerical Control	Computerized numerical control
CO	Connector Output	Connector output
CO/BO	Connector Output/Binector Output	Connector/binector output
COB ID	CAN Object-Identification	CAN object identification
CoL	Certificate of License	Certificate of License
COM	Common contact of a change-over relay	Center contact on a changeover contact
COMM	Commissioning	Commissioning
CP	Communication Processor	Communications processor
CPU	Central Processing Unit	Central processing unit
CRC	Cyclic Redundancy Check	Cyclic redundancy check
CSM	Control Supply Module	Control Supply Module
CU	Control Unit	Control unit
CUA	Control Unit Adapter	Control Unit Adapter
CUD	Control Unit DC MASTER	Control Unit DC MASTER
<b>D</b>		
DAC	Digital Analog Converter	Digital-analog converter
DC	Direct Current	Direct current
DCB	Drive Control Block	Drive Control Block
DCBRK	DC Brake	DC braking
DCC	Drive Control Chart	Drive Control Chart
DCN	Direct Current Negative	Direct current negative
DCP	Direct Current Positive	Direct current positive
DDS	Drive Data Set	Drive data set
DI	Digital Input	Digital input
DI/DO	Digital Input/Digital Output	Bidirectional digital input/output
DMC	DRIVE-CLiQ Hub Module Cabinet	DRIVE-CLiQ Hub Module Cabinet
DME	DRIVE-CLiQ Hub Module External	DRIVE-CLiQ Hub Module External



<b>Abbreviation</b>	<b>Source of the abbreviation</b>	<b>Meaning</b>
DMM	Double Motor Module	Double Motor Module
DO	Digital Output	Digital output
DO	Drive Object	Drive object
DP	Decentralized Peripherals	Distributed I/O
DPRAM	Dual Ported Random Access Memory	Dual-Port Random Access Memory
DQ	DRIVE-CLiQ	DRIVE-CLiQ
DRAM	Dynamic Random Access Memory	Dynamic Random Access Memory
DRIVE-CLiQ	Drive Component Link with IQ	Drive Component Link with IQ
DSC	Dynamic Servo Control	Dynamic Servo Control
DTC	Digital Time Clock	Timer
<b>E</b>		
EASC	External Armature Short-Circuit	External armature short-circuit
EDS	Encoder Data Set	Encoder data set
EEPROM	Electrically Erasable Programmable Read-Only Memory	Electrically Erasable Programmable Read-Only-Memory
ESD	Elektrostatisch gefährdete Baugruppen	Electrostatic sensitive devices
ELCB	Earth Leakage Circuit Breaker	Residual current operated circuit breaker
ELP	Earth Leakage Protection	Ground-fault monitoring
EMC	Electromagnetic Compatibility	Electromagnetic compatibility
EMF	Electromotive Force	Electromotive force
EMK	Elektromotorische Kraft	Electromotive force
EMV	Elektromagnetische Verträglichkeit	Electromagnetic compatibility
EN	Europäische Norm	European standard
EnDat	Encoder-Data-Interface	Encoder interface
EP	Enable Pulses	Enable pulses
EPOS	Einfachpositionierer	Basic positioner
ES	Engineering System	Engineering System
ESB	Ersatzschaltbild	Equivalent circuit diagram
ESD	Electrostatic Sensitive Devices	Electrostatic sensitive devices
ESM	Essential Service Mode	Essential service mode
ESR	Extended Stop and Retract	Extended stop and retract
<b>F</b>		
F...	Fault	Fault
FAQ	Frequently Asked Questions	Frequently asked questions
FBLOCKS	Free Blocks	Free function blocks
FCC	Function Control Chart	Function control chart
FCC	Flux Current Control	Flux current control
FD	Function Diagram	Function diagram
F-DI	Failsafe Digital Input	Fail-safe digital input
F-DO	Failsafe Digital Output	Fail-safe digital output

<b>Abbreviation</b>	<b>Source of the abbreviation</b>	<b>Meaning</b>
FEM	Fremderregter Synchronmotor	Separately excited synchronous motor
FEPROM	Flash-EPROM	Non-volatile write and read memory
FG	Function Generator	Function generator
FI	-	Residual current
FOC	Fiber-Optic Cable	Fiber-optic cable
FP	Funktionsplan	Function diagram
FPGA	Field Programmable Gate Array	Field programmable gate array
FW	Firmware	Firmware
<b>G</b>		
GB	Gigabyte	Gigabyte
GC	Global Control	Global control telegram (broadcast telegram)
GND	Ground	Reference potential for all signal and operating voltages, usually defined as 0 V (also referred to as M)
GSD	Gerätstammdatei	Generic station description: describes the features of a PROFIBUS slave
GSV	Gate Supply Voltage	Gate supply voltage
GUID	Globally Unique Identifier	Globally Unique Identifier
<b>H</b>		
HF	High frequency	High frequency
HFD	Hochfrequenzdrossel	High-frequency reactor
HLA	Hydraulic Linear Actuator	Hydraulic linear drive
HLG	Hochlaufgeber	Ramp-function generator
HM	Hydraulic Module	Hydraulic Module
HMI	Human Machine Interface	Human machine interface
HTL	High-Threshold Logic	Logic with high fault threshold
HW	Hardware	Hardware
<b>I</b>		
i. V.	In Vorbereitung	Under development: This property is currently not available
I/O	Input/Output	Input/output
I2C	Inter-Integrated Circuit	Internal serial data bus
IASC	Internal Armature Short-Circuit	Internal armature short-circuit
IBN	Inbetriebnahme	Commissioning
ID	Identifier	Identification
IE	Industrial Ethernet	Industrial Ethernet
IEC	International Electrotechnical Commission	International Electrotechnical Commission
IF	Interface	Interface
IGBT	Insulated Gate Bipolar Transistor	Bipolar transistor with insulated control electrode
IGCT	Integrated Gate-Controlled Thyristor	Semiconductor power switch with integrated control electrode

<b>Abbreviation</b>	<b>Source of the abbreviation</b>	<b>Meaning</b>
IL	Impulslöschung	Pulse suppression
IP	Internet Protocol	Internet Protocol
IPO	Interpolator	Interpolator
IT	Isolé Terre	Non-grounded three-phase line supply
IVP	Internal Voltage Protection	Internal voltage protection
<b>J</b>		
JOG	Jogging	Jog
<b>K</b>		
KDV	Kreuzweiser Datenvergleich	Crosswise data comparison
KHP	Know-how protection	Know-how protection
KIP	Kinetische Pufferung	Kinetic buffering
Kp	-	Proportional gain
KTY	-	Special temperature sensor
<b>L</b>		
L	-	Symbol for inductance
LED	Light Emitting Diode	Light emitting diode
LIN	Linearmotor	Linear motor
LR	Lageregler	Position controller
LSB	Least Significant Bit	Least significant bit
LSC	Line-Side Converter	Line-side converter
LSS	Line-Side Switch	Line-side switch
LU	Length Unit	Length unit
FO cable	Lichtwellenleiter	Fiber-optic cable
<b>M</b>		
M	-	Symbol for torque
M	Masse	Reference potential for all signal and operating voltages, usually defined as 0 V (also referred to as GND)
MB	Megabyte	Megabyte
MCC	Motion Control Chart	Motion Control Chart
MDI	Manual Data Input	Manual data input
MDS	Motor Data Set	Motor data set
MLFB	Maschinenlesbare Fabrikatebezeichnung	Machine-readable product code
MM	Motor Module	Motor Module
MMC	Man-Machine Communication	Man-machine communication
MMC	Micro Memory Card	Micro memory card
MSB	Most Significant Bit	Most significant bit
MSC	Motor-Side Converter	Motor-side converter
MSCY_C1	Master Slave Cycle Class 1	Cyclic communication between master (class 1) and slave

A.1 List of abbreviations

<b>Abbreviation</b>	<b>Source of the abbreviation</b>	<b>Meaning</b>
MSC	Motorstromrichter	Motor-side converter
MT	Messtaster	Probe
<b>N</b>		
N. C.	Not Connected	Not connected
N...	No Report	No report or internal message
NAMUR	Normenarbeitsgemeinschaft für Mess- und Regeltechnik in der chemischen Industrie	Standardization association for measurement and control in chemical industries
NC	Normally Closed (contact)	NC contact
NC	Numerical Control	Numerical control
NEMA	National Electrical Manufacturers Association	Standardization body in the US
NM	Nullmarke	Zero mark
NO	Normally Open (contact)	NO contacts
LSC	Netzstromrichter	Line-side converter
NVRAM	Non-Volatile Random Access Memory	Non-volatile read/write memory
<b>O</b>		
OA	Open Architecture	Software component (technology package) which provides additional functions for the SINAMICS drive system
OAIF	Open Architecture Interface	Version of the SINAMICS firmware from which the OA-application can be used
OASP	Open Architecture Support Package	Expands the STARTER commissioning tool by the corresponding OA-application
OC	Operating Condition	Operating condition
OEM	Original Equipment Manufacturer	Original equipment manufacturer
OLP	Optical Link Plug	Bus connector for fiber-optic cable
OMI	Option Module Interface	Option Module Interface
<b>P</b>		
p...	-	Adjustable parameters
P1	Processor 1	CPU 1
P2	Processor 2	CPU 2
PB	PROFIBUS	PROFIBUS
PcCtrl	PC Control	Master control
PD	PROFIdrive	PROFIdrive
PDS	Power unit Data Set	Power unit data set
PE	Protective Earth	Protective ground
PELV	Protective Extra Low Voltage	Safety extra-low voltage
PEM	Permanenterregter Synchronmotor	Permanent-magnet synchronous motor
PG	Programmiergerät	Programming device
PI	Proportional Integral	Proportional integral
PID	Proportional Integral Differential	Proportional integral differential
PLC	Programmable Logical Controller	Programmable logic controller

<b>Abbreviation</b>	<b>Source of the abbreviation</b>	<b>Meaning</b>
PLL	Phase-Locked Loop	Phase-locked loop
PM	Power Module	Power Module
PN	PROFINET	PROFINET
PNO	PROFIBUS Nutzerorganisation	PROFIBUS user organization
PPI	Point to Point Interface	Point-to-point interface
PRBS	Pseudo Random Binary Signal	White noise
PROFIBUS	Process Field Bus	Serial data bus
PS	Power Supply	Power supply
PSA	Power Stack Adapter	Power Stack Adapter
PTC	Positive Temperature Coefficient	Positive temperature coefficient
PTP	Point To Point	Point-to-point
PWM	Pulse Width Modulation	Pulse width modulation
PZD	Prozessdaten	Process data
<b>Q</b>		
<b>R</b>		
r...	-	Display parameters (read only)
RAM	Random Access Memory	Read/write memory
RCCB	Residual Current Circuit Breaker	Residual current operated circuit breaker
RCD	Residual Current Device	Residual current operated circuit breaker
RCM	Residual Current Monitor	Residual current monitor
RFG	Ramp-Function Generator	Ramp-function generator
RJ45	Registered Jack 45	Term for an 8-pin socket system for data transmission with shielded or non-shielded multi-wire copper cables
RKA	Rückkühlanlage	Cooling unit
RLM	Renewable Line Module	Renewable Line Module
RO	Read Only	Read only
ROM	Read-Only Memory	Read-only memory
RPDO	Receive Process Data Object	Receive Process Data Object
RS232	Recommended Standard 232	Interface standard for cable-connected serial data transmission between a sender and receiver (also known as EIA232)
RS485	Recommended Standard 485	Interface standard for a cable-connected differential, parallel, and/or serial bus system (data transmission between a number of senders and receivers, also known as EIA485)
RTC	Real Time Clock	Realtime clock
RZA	Raumzeigerapproximation	Space vector approximation
<b>S</b>		
S1	-	Continuous duty
S3	-	Intermittent duty
SAM	Safe Acceleration Monitor	Safe acceleration monitoring

<b>Abbreviation</b>	<b>Source of the abbreviation</b>	<b>Meaning</b>
SBC	Safe Brake Control	Safe brake control
SBH	Sicherer Betriebshalt	Safe operating stop
SBR	Safe Brake Ramp	Safe brake ramp monitoring
SBT	Safe Brake Test	Safe brake test
SCA	Safe Cam	Safe cam
SD Card	SecureDigital Card	Secure digital memory card
SDI	Safe Direction	Safe motion direction
SE	Sicherer Software-Endschalter	Safe software limit switch
SG	Sicher reduzierte Geschwindigkeit	Safely-limited speed
SGA	Sicherheitsgerichteter Ausgang	Safety-related output
SGE	Sicherheitsgerichteter Eingang	Safety-related input
SH	Sicherer Halt	Safe standstill
SI	Safety Integrated	Safety Integrated
SIL	Safety Integrity Level	Safety Integrity Level
SLM	Smart Line Module	Smart Line Module
SLP	Safely-Limited Position	Safely-limited position
SLS	Safely-Limited Speed	Safely-limited speed
SLVC	Sensorless Vector Control	Vector control without encoder (sensorless)
SM	Sensor Module	Sensor Module
SMC	Sensor Module Cabinet	Sensor Module Cabinet
SME	Sensor Module External	Sensor Module External
SMI	SINAMICS Sensor Module Integrated	SINAMICS Sensor Module Integrated
SMM	Single Motor Module	Single Motor Module
SN	Sicherer Software-Nocken	Safe software cam
SOS	Safe Operating Stop	Safe operating stop
SP	Service Pack	Service pack
SP	Safe Position	Safe position
SPC	Setpoint Channel	Setpoint channel
SPI	Serial Peripheral Interface	Serial peripheral interface
SPS	Speicherprogrammierbare Steuerung	Programmable logic controller
SS1	Safe Stop 1	Safe stop 1 (monitored for time and ramping up)
SS2	Safe Stop 2	Safe Stop 2
SSI	Synchronous Serial Interface	Synchronous serial interface
SSM	Safe Speed Monitor	Safe feedback from speed monitor
SSP	SINAMICS Support Package	SINAMICS support package
STO	Safe Torque Off	Safe torque off
STW	Steuerwort	Control word

Abbreviation	Source of the abbreviation	Meaning
<b>T</b>		
TB	Terminal Board	Terminal board
TIA	Totally Integrated Automation	Totally Integrated Automation
TM	Terminal Module	Terminal Module
TN	Terre Neutre	Grounded three-phase line supply
Tn	-	Integral time
TPDO	Transmit Process Data Object	Transmit process data object
TT	Terre Terre	Grounded three-phase line supply
TTL	Transistor-Transistor-Logic	Transistor-transistor logic
Tv	-	Rate time
<b>U</b>		
UL	Underwriters Laboratories Inc.	Underwriters Laboratories Inc.
UPS	Uninterruptible Power Supply	Uninterruptible power supply
UPS	Unterbrechungsfreie Stromversorgung	Uninterruptible power supply
UTC	Universal Time Coordinated	Universal time coordinated
<b>V</b>		
VC	Vector Control	Vector control
Vdc	-	DC-link voltage
VdcN	-	Partial DC link voltage, negative
VdcP	-	Partial DC link voltage, positive
VDE	Verband Deutscher Elektrotechniker	Verband Deutscher Elektrotechniker [Association of German Electrical Engineers]
VDI	Verein Deutscher Ingenieure	Verein Deutscher Ingenieure [Association of German Engineers]
VPM	Voltage Protection Module	Voltage Protection Module
Vpp	Volt peak to peak	Volt peak to peak
VSM	Voltage Sensing Module	Voltage Sensing Module
<b>W</b>		
WEA	Wiedereinschaltautomatik	Automatic restart
WZM	Werkzeugmaschine	Machine tool
<b>X</b>		
XML	Extensible Markup Language	Extensible markup language (standard language for web publishing and document management)
<b>Y</b>		
<b>Z</b>		
ZK	DC Link	DC Link
ZM	Zero Mark	Zero mark
ZSW	Status word	Status word

## A.2 Terminal description

### A.2.1 Spring-loaded terminals

The type of spring-loaded terminal can be taken from the interface description of the particular component.

Table A- 1 Connectable conductor cross-sections for spring-loaded terminals

Spring-loaded terminal type			
1	Connectable cable cross-sections	Rigid Flexible Flexible with end sleeve without plastic sleeve AWG/kcmil	0.14 ... 0.5 mm <sup>2</sup> 0.14 ... 0.5 mm <sup>2</sup> 0.25 ... 0.5 mm <sup>2</sup> 26 ... 20
	Stripped length	8 mm	
2	Connectable cable cross-sections	Flexible	0.08 ... 2.5 mm <sup>2</sup>
	Stripped length	8 ... 9 mm	
3	Connectable cable cross-sections	Rigid Flexible Flexible with end sleeve without plastic sleeve Flexible with end sleeve with plastic sleeve AWG/kcmil	0.2 ... 1.5 mm <sup>2</sup> 0.2 ... 1.5 mm <sup>2</sup> 0.25 ... 1.5 mm <sup>2</sup> 0.25 ... 0.75 mm <sup>2</sup> 24 ... 16
	Stripped length	10 mm	
4	Connectable cable cross-sections	AWG	25 ... 95 mm <sup>2</sup> 4 ... 4/0
	Stripped length	35 mm	
5	Connectable cable cross-sections	Rigid Flexible Flexible with end sleeve without plastic sleeve Flexible with end sleeve with plastic sleeve AWG/kcmil	0.2 ... 10 mm <sup>2</sup> 0.2 ... 6 mm <sup>2</sup> 0.25 ... 6 mm <sup>2</sup> 0.25 ... 4 mm <sup>2</sup> 24 ... 8
	Stripped length	15 mm	

### A.2.2 Screw terminals

The type of screw terminal can be taken from the interface description of the particular component.

Table A- 2 Connectable conductor cross-sections and tightening torques for screw terminals

Screw terminal type			
1	Connectable cable cross-sections	Rigid, flexible With end sleeve, without plastic sleeve With end sleeve, with plastic sleeve	0.08 ... 1.5 mm <sup>2</sup> 0.25 ... 1.5 mm <sup>2</sup> 0.25 ... 0.5 mm <sup>2</sup>
	Stripped length	7 mm	



Screw terminal type			
	Tool	Screwdriver 0.4 x 2.0 mm	
	Tightening torque	0.22 ... 0.25 Nm	
1_1	Connectable cable cross-sections	Rigid, flexible	0.14 ... 1.5 mm <sup>2</sup>
		With end sleeve, without plastic sleeve	0.25 ... 1.5 mm <sup>2</sup>
		With end sleeve, with plastic sleeve	0.25 ... 0.5 mm <sup>2</sup>
	Stripped length	7 mm	
	Tool	Screwdriver 0.4 x 2.5 mm	
Tightening torque	0.22 ... 0.25 Nm		
2	Connectable cable cross-sections	Rigid, flexible	0.2 ... 2.5 mm <sup>2</sup>
		With end sleeve, without plastic sleeve	0.2 ... 2.5 mm <sup>2</sup>
		With end sleeve, with plastic sleeve	0.2 ... 1.5 mm <sup>2</sup>
		AWG / kcmil	22 ... 12
	Stripped length	6 ... 7 mm	
Tool	Screwdriver 0.5 x 3 mm		
Tightening torque	0.4 ... 0.5 Nm		
3	Connectable cable cross-sections	Flexible	0.2 ... 2.5 mm <sup>2</sup>
		With end sleeve, without plastic sleeve	0.25 ... 1 mm <sup>2</sup>
		With end sleeve, with plastic sleeve	0.25 ... 1 mm <sup>2</sup>
	Stripped length	9 mm	
	Tool	Screwdriver 0.6 x 3.5 mm	
Tightening torque	0.5 ... 0.6 Nm		
4	Connectable cable cross-sections	Flexible	0.2 ... 4 mm <sup>2</sup>
		With end sleeve, without plastic sleeve	0.25 ... 4 mm <sup>2</sup>
		With end sleeve, with plastic sleeve	0.25 ... 4 mm <sup>2</sup>
	Stripped length	7 mm	
	Tool	Screwdriver 0.6 x 3.5 mm	
Tightening torque	0.5 ... 0.6 Nm		
5	Connectable cable cross-sections	Flexible	0.5 ... 6 mm <sup>2</sup>
		With end sleeve, without plastic sleeve	0.5 ... 6 mm <sup>2</sup>
		With end sleeve, with plastic sleeve	0.5 ... 6 mm <sup>2</sup>
	Stripped length	12 mm	
	Tool	Screwdriver 1.0 x 4.0 mm	
Tightening torque	1.2 ... 1.5 Nm		
6	Connectable cable cross-sections	Flexible	0.5 ... 10 mm <sup>2</sup>
		With end sleeve, without plastic sleeve	0.5 ... 10 mm <sup>2</sup>
		With end sleeve, with plastic sleeve	0.5 ... 10 mm <sup>2</sup>
	Stripped length	11 mm	
	Tool	Screwdriver 1.0 x 4.0 mm	
Tightening torque	1.5 ... 1.8 Nm		
7	Connectable cable cross-sections	0.5 ... 16 mm <sup>2</sup>	
		Stripped length	14 mm
	Tool	Screwdriver 1.0 x 4.0 mm	
	Tightening torque	1.5 ... 1.7 Nm	

## A.3 Cable lugs

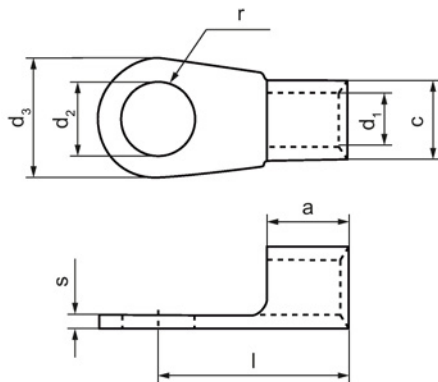
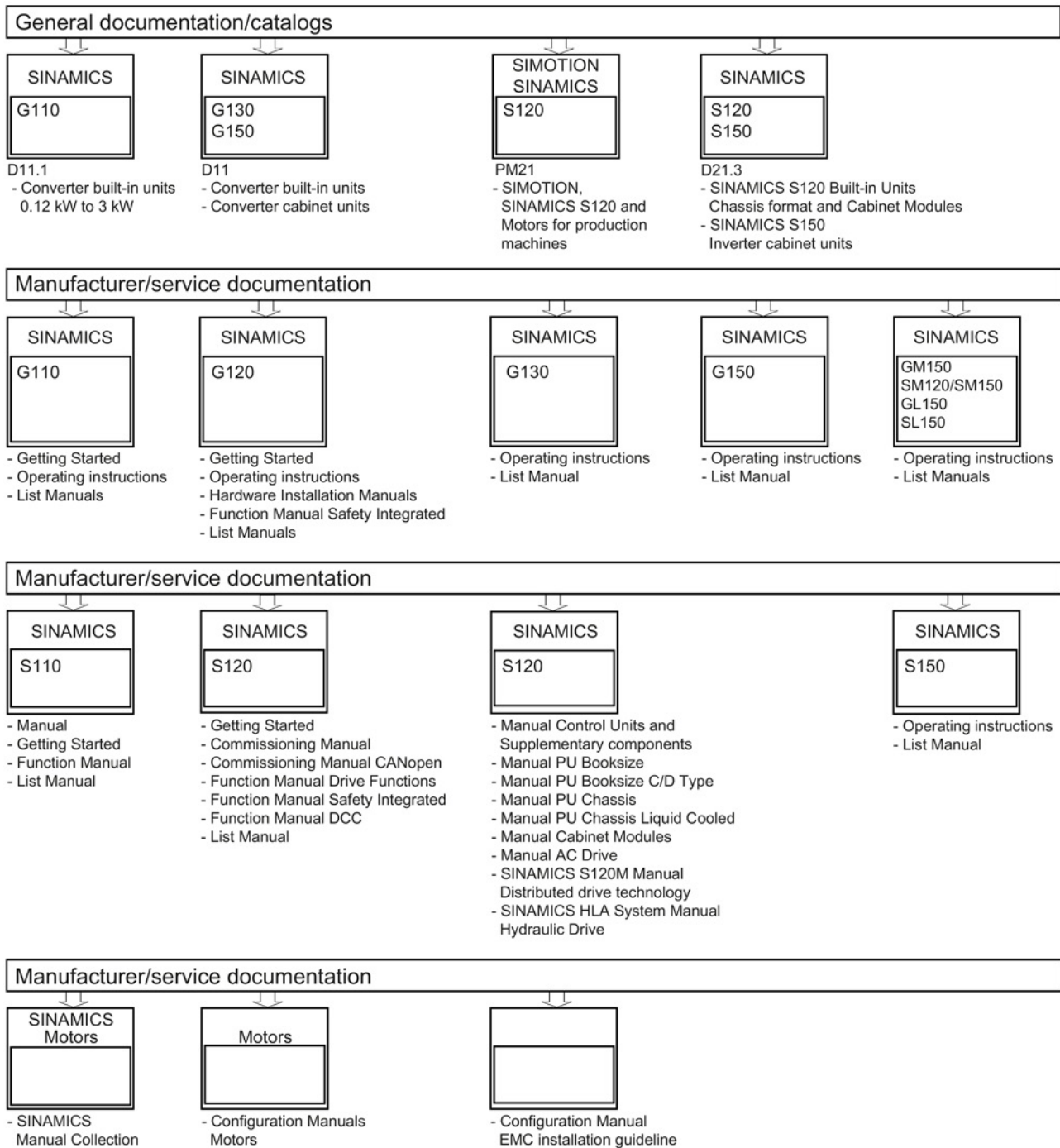

Figure A-1 Dimension drawing of cable lugs

Table A-3 Dimensions of cable lugs

Screw/bolt	Cable cross-section [mm <sup>2</sup> ]	a [mm]	c [mm]	d <sub>1</sub> [mm]	d <sub>2</sub> [mm]	d <sub>3</sub> [mm]	l [mm]	r [mm]	s [mm]
M4	1 ... 2.5	5	4.5	2.3	4.3	8	12	6.0	0.8
M5	1 ... 2.5	5	4.5	2.3	5.3	10	14	6.5	0.8
M6	1 ... 2.5	5	4.5	2.3	6.5	11	16	7.5	0.8
M8	2.5	5	4.5	2.3	8.4	14	17	10.0	0.8

## A.4 Documentation overview





# Index

## A

### Address

Setting the PROFIBUS address, 68

Ambient temperature, 35

## B

Basic Operator Panel BOP20, 82

## C

CAN CBC10 Communication Board, 88

CBE20 Ethernet Communication Board, 93

### Components

Basic Operator Panel BOP20, 82

CAN CBC10 Communication Board, 88

CBE20 Ethernet Communication Board, 93

Control Unit CU320-2 DP, 59

Control Unit CU320-2 PN, 42

DRIVE-CLiQ encoder, 317

DRIVE-CLiQ Hub Module DMC20, 192

DRIVE-CLiQ Hub Module External DME20, 200

Sensor Module Cabinet-Mounted SMC10, 230

Sensor Module Cabinet-Mounted SMC20, 240

Sensor Module Cabinet-Mounted SMC30, 249

Sensor Module Cabinet-Mounted SMC40, 267

Sensor Module External SME120, 290

Sensor Module External SME125, 303

Sensor Module External SME20, 277

Sensor Module External SME25, 284

Terminal Board TB30, 98

Terminal Module TM120, 168

Terminal Module TM15, 106

Terminal Module TM150, 179

Terminal Module TM31, 119

Terminal Module TM41, 136

Terminal Module TM54F, 149

Voltage Sensing Module, 207

### Connector coding

Terminal Module TM15, 117

Terminal Module TM31, 134

Control Unit CU320-2 DP, 59

LEDs after booting, 75

LEDs during booting, 74

Control Unit CU320-2 PN, 42

LEDs after booting, 57

LEDs during booting, 56

## D

### Diagnostics via LEDs

CAN CBC10 Communication Board, 91

CBE20 Ethernet Communication Board, 94

Control Unit CU320-2 DP, 75

Control Unit CU320-2 PN, 57

DRIVE-CLiQ Hub Module DMC20, 195

Sensor Module Cabinet SMC10, 235

Sensor Module Cabinet SMC20, 245

Sensor Module Cabinet SMC30, 258

Sensor Module Cabinet SMC40, 273

Terminal Module TM120, 175

Terminal Module TM15, 113

Terminal Module TM150, 186

Terminal Module TM31, 130

Terminal Module TM41, 144

Terminal Module TM54F, 162

Voltage Sensing Module VSM10, 219

### Dimension drawings

Control Unit CU320-2 DP, 76

Control Unit CU320-2 PN, 58

DRIVE-CLiQ encoder, 318

DRIVE-CLiQ Hub Module DMC20, 196

DRIVE-CLiQ Hub Module External DME20, 204

Sensor Module Cabinet SMC10, 236

Sensor Module Cabinet SMC20, 246

Sensor Module Cabinet SMC30, 259

Sensor Module Cabinet SMC40, 274

Sensor Module External SME120, 300

Sensor Module External SME125, 314

Sensor Module External SME20, 281

Sensor Module External SME25, 287

Terminal Module TM120, 176

Terminal Module TM15, 114

Terminal Module TM150, 187

Terminal Module TM31, 131

Terminal Module TM41, 145

Terminal Module TM54F, 164

Voltage Sensing Module VSM10, 220

DRIVE-CLiQ encoder, 317

DRIVE-CLiQ Hub Module DMC20, 192

DRIVE-CLiQ Hub Module External DME20, 200

**F**

Field of application, 27

**I**

Installation

- Basic Operator Panel BOP20, 85
- CBE20 Ethernet Communication Board, 96
- Communication Board CBC10, 92
- Control Unit CU320-2 DP/PN, 78
- DRIVE-CLiQ encoder, 320
- DRIVE-CLiQ Hub Module DMC20, 197
- Sensor Module Cabinet, 237, 247, 260
- Sensor Module External SME120, 300
- Sensor Module External SME125, 314
- Sensor Module External SME20/SME25, 282, 288
- Sensor Modules Cabinet SMC40, 275
- Terminal Board TB30, 103
- Terminal Module TM120, 177
- Terminal Module TM150, 188
- Terminal Modules, 115, 132, 146, 165
- Voltage Sensing Module VSM10, 221

Interface descriptions

- Basic Operator Panel BOP20, 82
- CAN CBC10 Communication Board, 88
- CBE20 Ethernet Communication Board, 93
- Control Unit CU320-2 DP, 60
- Control Unit CU320-2 PN, 43
- DRIVE-CLiQ Hub Module DMC20, 193
- DRIVE-CLiQ Hub Module External DME20, 201
- Sensor Module Cabinet SMC10, 231
- Sensor Module Cabinet SMC20, 241
- Sensor Module Cabinet SMC30, 250
- Sensor Module Cabinet SMC40, 268
- Sensor Module External SME120, 292
- Sensor Module External SME125, 305
- Sensor Module External SME20, 277
- Sensor Module External SME25, 284
- Terminal Board TB30, 98
- Terminal Module TM120, 169
- Terminal Module TM150, 180
- Terminal Module TM31, 120
- Terminal Module TM41, 137
- Terminal Module TM54F, 150
- Voltage Sensing Module VSM10, 210

Interface Descriptions

- Terminal Module TM15, 107

Introduction, 30

**L**

LEDs

- CAN CBC10 Communication Board, 91
- CBE20 Ethernet Communication Board, 94
- Control Unit CU320-2 DP, 75
- Control Unit CU320-2 PN, 57
- DRIVE-CLiQ Hub Module DMC20, 195
- Sensor Module Cabinet SMC10, 235
- Sensor Module Cabinet SMC20, 245
- Sensor Module Cabinet SMC30, 258
- Sensor Module Cabinet SMC40, 273
- Terminal Module TM120, 175
- Terminal Module TM15, 113
- Terminal Module TM150, 186
- Terminal Module TM31, 130
- Terminal Module TM41, 144
- Terminal Module TM54F, 162
- Voltage Sensing Module VSM10, 219

**P**

Platform Concept, 28

PROFIBUS

- Setting the address, 68

Protective conductor connection and shield support

- DRIVE-CLiQ Hub Module DMC20, 199
- Terminal Module TM120, 178
- Terminal Module TM15, 116
- Terminal Module TM150, 189
- Terminal Module TM31, 133
- Terminal Module TM41, 147
- Terminal Module TM54F, 166
- Voltage Sensing Module VSM10, 222

**S**

Safety instructions

- Control Units, 40
- Hub Modules, 191
- Option boards, 87
- Sensor Module External, 291, 304
- Sensor Modules and encoders, 228
- Terminal Modules, 105
- Voltage Sensing Modules VSM10, 208

Sensor Module Cabinet-Mounted SMC10, 230

Sensor Module Cabinet-Mounted SMC20, 240

Sensor Module Cabinet-Mounted SMC30, 249

Sensor Module Cabinet-Mounted SMC40, 267

Sensor Module External SME120, 290

Sensor Module External SME125, 303

Sensor Module External SME20, 277

Sensor Module External SME25, 284  
Sensor Modules  
  Overview, 226  
Specification of encoder systems and encoders  
  Sensor Module Cabinet SMC30, 262  
Storage, 35  
Switches for PROFIBUS address, 68

## T

Technical data  
  CAN CBC10 Communication Board, 92  
  Control Unit CU320-2 DP, 77  
  Control Unit CU320-2 PN, 59  
  DRIVE-CLiQ encoder, 323  
  DRIVE-CLiQ Hub Module DMC20, 199  
  DRIVE-CLiQ Hub Module External DME20, 205  
  Electronics power supply, 35  
  Sensor Module Cabinet SMC10, 238  
  Sensor Module Cabinet SMC20, 248  
  Sensor Module Cabinet SMC30, 262  
  Sensor Module Cabinet SMC40, 276  
  Sensor Module External SME120, 301  
  Sensor Module External SME125, 315  
  Sensor Module External SME20, 282  
  Sensor Module External SME25, 288  
  Terminal Board TB30, 104  
  Terminal Module TM120, 179  
  Terminal Module TM15, 118  
  Terminal Module TM150, 190  
  Terminal Module TM31, 135  
  Terminal Module TM41, 148  
  Terminal Module TM54F, 167  
  Voltage Sensing Module VSM10, 223  
Terminal Board TB30, 98  
Terminal Module TM120, 168  
Terminal Module TM15, 106  
Terminal Module TM150, 179  
Terminal Module TM31, 119  
Terminal Module TM41, 136  
Terminal Module TM54F, 149  
Tightening torques, 325  
Totally Integrated Automation, 28  
Transport, 35

## V

Voltage Sensing Module, 207

Siemens AG  
Industry Sector  
Drive Technologies  
Motion Control Systems  
Postfach 3180  
91050 ERLANGEN  
GERMANY

Subject to change without prior notice  
© Siemens AG 2004 - 2015

[www.siemens.com/motioncontrol](http://www.siemens.com/motioncontrol)