

Equipment Manual 06/2005 Edition

sinamics

SINAMICS S120
Booksize Power Sections Cold Plate

SIEMENS

SIEMENS

SINAMICS

SINAMICS S120 Equipment Manual Booksize Cold-Plate Power Sections

Manual

Preface	
Description	1
Cold plate with external air heat sinks	2
Cold plate with internal liquid cooling	3
Line Connection Booksize	4
Active line modules with cold plate	5
Smart Line Modules (5 kW and 10 kW) with cold plate	6
Motor Modules with Cold Plate	7
Connection adapter	8
Internal Liquid Cooling	9
DC link components	10
Options	11
Cabinet Design and EMC	12
Service and Maintenance	13
Spring-Loaded Terminals/Screw Terminals	A
List of Abbreviations	B
References	C

(GH4), Edition 06.2005

6SL3097-2AJ00-0BP2

Safety Guidelines

This manual contains notices you have to observe in order to ensure your personal safety, as well as to prevent damage to property. The notices referring to your personal safety are highlighted in the manual by a safety alert symbol, notices referring only to property damage have no safety alert symbol. These notices shown below are graded according to the degree of danger.



Danger

indicates that death or severe personal injury **will** result if proper precautions are not taken.



Warning

indicates that death or severe personal injury **may** result if proper precautions are not taken.



Caution

with a safety alert symbol, indicates that minor personal injury can result if proper precautions are not taken.

Caution

without a safety alert symbol, indicates that property damage can result if proper precautions are not taken.

Notice

indicates that an unintended result or situation can occur if the corresponding information is not taken into account.

If more than one degree of danger is present, the warning notice representing the highest degree of danger will be used. A notice warning of injury to persons with a safety alert symbol may also include a warning relating to property damage.

Qualified Personnel

The device/system may only be set up and used in conjunction with this documentation. Commissioning and operation of a device/system may only be performed by **qualified personnel**. Within the context of the safety notes in this documentation qualified persons are defined as persons who are authorized to commission, ground and label devices, systems and circuits in accordance with established safety practices and standards.

Prescribed Usage

Note the following:



Warning

This device may only be used for the applications described in the catalog or the technical description and only in connection with devices or components from other manufacturers which have been approved or recommended by Siemens. Correct, reliable operation of the product requires proper transport, storage, positioning and assembly as well as careful operation and maintenance.

Trademarks

All names identified by ® are registered trademarks of the Siemens AG. The remaining trademarks in this publication may be trademarks whose use by third parties for their own purposes could violate the rights of the owner.

Disclaimer of Liability

We have reviewed the contents of this publication to ensure consistency with the hardware and software described. Since variance cannot be precluded entirely, we cannot guarantee full consistency. However, the information in this publication is reviewed regularly and any necessary corrections are included in subsequent editions.

Preface

Information on the SINAMICS S Documentation

The SINAMICS S documentation is divided into the following areas:

- General documentation/catalogs
- Manufacturer/service documentation
- Electronic documentation

This documentation is an integral part of the manufacturer/service documentation developed for SINAMICS. All documents can be obtained separately.

You can obtain detailed information about the documents named in the documentation overview and other documents available for SINAMICS from your local Siemens office.

For the sake of simplicity, this documentation does not contain all detailed information about all types of the product and cannot cover every conceivable case of installation, operation, or maintenance.

The contents of this documentation are not part of an earlier or existing agreement, a promise, or a legal agreement, nor do they change this. All obligations entered into by Siemens result from the respective contract of sale that contains the complete and sole valid warranty arrangements. These contractual warranty provisions are neither extended nor curbed as a result of the statements made in this documentation.

Audience

This documentation is aimed at machine and plant builders, commissioning engineers, and service personnel who use SINAMICS.

Objective

This manual describes the hardware components of the SINAMICS S system. It provides information about installation, electrical connection, and cabinet design.

Technical Information

Hotline

If you have any further questions, please call our hotline:

A&D Technical Support

Tel.: +49 (0) 180 5050 - 222

Fax: +49 (0) 180 5050 - 223

E-mail: adsupport@siemens.com

Internet: <http://www.siemens.com/automation/support-request>

Please send any questions about the documentation (suggestions for improvement, corrections, and so on) to the following fax number or e-mail address:

Fax: +49 (0) 9131 98 - 63315

E-mail: motioncontrol.docu@erf.siemens.com

Fax form: See feedback page at the end of this publication

Internet Address

Up-to-date information about our products can be found on the Internet at the following address:

<http://www.siemens.com/motioncontrol>

You can find information on SINAMICS S120 at:

<http://www.siemens.com/sinamics>.

ESD Notices



Caution

Electrostatic sensitive devices (ESDs) are individual components, integrated circuits, or boards that may be damaged by either electrostatic fields or electrostatic discharge.

Regulations for handling ESD components:

When handling components, make sure that personnel, workplaces, and packaging are well earthed.

Personnel in ESD areas with conductive flooring may only handle electronic components if:

They are grounded with an ESD wrist band

They are wearing ESD shoes or ESD shoe grounding straps

Electronic boards should only be touched if absolutely necessary. They must only be handled on the front panel or, in the case of printed circuit boards, at the edge.

Electronic boards must not come into contact with plastics or items of clothing containing synthetic fibers.

Boards must only be placed on conductive surfaces (work surfaces with ESD surface, conductive ESD foam, ESD packing bag, ESD transport container).

Do not place boards near display units, monitors, or television sets (minimum distance from screen: 10 cm).

Measurements must only be taken on boards when the measuring instrument is grounded (via protective conductors, for example) or the measuring probe is briefly discharged before measurements are taken with an isolated measuring device (for example, touching a bare metal housing).

Safety Guidelines



Danger

Commissioning shall not start until you have ensured that the machine in which the components described here are to be installed complies with Directive 98/37/EC.

SINAMICS S equipment must only be commissioned by suitably qualified personnel.

The personnel must take into account the information provided in the technical customer documentation for the product, and be familiar with and observe the specified danger and warning notices.

When electrical equipment and motors are operated, the electrical circuits automatically conduct a dangerous voltage.

Dangerous mechanical movements may occur in the system during operation.

All work on the electrical system must be performed after the system has been switched off and disconnected from the power supply.

SINAMICS S equipment with three-phase motors may only be connected to the line system via residual current devices (RCDs) if compatibility of the SINAMICS equipment with the RCD has been ensured as specified in EN 50178, Subsection 5.2.11.2.



Warning

Correct and safe operation of SINAMICS S equipment assumes correct transportation, storage, setup, and installation, as well as careful operation and maintenance.

The details in the catalogs and proposals also apply to the design of special equipment versions.

In addition to the danger and warning information provided in the technical customer documentation, the applicable national, local, and system-specific regulations and requirements must be taken into account.

Only protective extra-low voltages (PELVs) that comply with EN60204-1 must be connected to all connections and terminals between 0 and 48 V.

Caution

As part of routine tests, SINAMICS equipment with three-phase motors will undergo a voltage test in accordance with EN 50178. Before the voltage test is performed on the electrical equipment of industrial machines to EN 60204-1, Section 19.4, all connectors of SINAMICS equipment must be disconnected/unplugged to prevent the equipment from being damaged.

Motors must be connected in accordance with the circuit diagram provided. They must not be connected directly to the three-phase supply because this will damage them.

Note

When operated in dry operating areas, SINAMICS equipment with three-phase motors conforms to low-voltage Directive 73/23/EEC.

SINAMICS equipment with three-phase motors conforms to EMC Directive 89/336/EEC in the configurations specified in the associated EC Certificate of Conformity.

Caution

Operating the equipment in the immediate vicinity (< 1.5 m) of mobile telephones with a transmitter power of > 1 W may lead to incorrect operation.

Table of contents

	Preface	iii
1	Description	1-1
1.1	Cold-plate cooling	1-1
1.2	System Data.....	1-3
2	Cold plate with external air heat sinks	2-1
2.1	Overview	2-1
2.2	Example: cold plate with external air heat sink.....	2-1
2.2.1	Setup	2-1
2.2.2	Sample setup: cold plate with external air heat sink.....	2-2
2.3	Example: cold plate with external liquid heat sink	2-5
2.3.1	Setup	2-5
2.3.2	Sample setup: cold plate with external liquid heat sink	2-6
3	Cold plate with internal liquid cooling	3-1
3.1	Principle of internal liquid cooling.....	3-1
4	Line Connection Booksize	4-1
4.1	Introduction	4-1
4.2	Overview: line filter.....	4-3
4.3	Basic Line Filter for Active Line Modules.....	4-4
4.3.1	Description	4-4
4.3.2	Safety information	4-5
4.3.3	Interface description.....	4-6
4.3.3.1	Overview	4-6
4.3.3.2	Line/load connection	4-7
4.3.4	Dimension Drawing.....	4-8
4.3.5	Technical Specifications	4-8
4.4	Wideband Line Filter for Active Line Modules	4-9
4.4.1	Description	4-9
4.4.2	Safety information	4-10
4.4.3	Interface description.....	4-11
4.4.3.1	Line/load connection	4-12
4.4.4	Dimension Drawing.....	4-13
4.4.5	Technical Specifications	4-14

4.5	Line filters for Smart Line Modules	4-14
4.5.1	Description	4-14
4.5.2	Safety information	4-15
4.5.3	Interface description	4-16
4.5.3.1	Overview	4-16
4.5.3.2	Line/load connection	4-17
4.5.4	Dimension Drawings	4-18
4.5.5	Technical Specifications.....	4-19
4.6	Line reactors for Active Line Modules	4-20
4.6.1	Description	4-20
4.6.2	Safety information	4-20
4.6.3	Connection description.....	4-21
4.6.3.1	Line/load connection	4-22
4.6.4	Dimension Drawings	4-22
4.6.5	Technical specifications	4-23
4.7	Line reactors for Smart Line Modules	4-24
4.7.1	Description	4-24
4.7.2	Safety information	4-24
4.7.3	Connection description.....	4-25
4.7.3.1	Overview	4-25
4.7.3.2	Line/load connection	4-26
4.7.4	Dimension Drawings	4-27
4.7.5	Technical specifications	4-30
4.8	Line connection variants	4-31
4.8.1	Methods of line connection	4-31
4.8.2	Operation of the line connection components on the supply network	4-33
4.8.3	Operation of the line connection components via an autotransformer	4-34
4.8.4	Operation of the line connection components via an isolating transformer	4-36
4.8.5	Line connection via a ground-fault circuit interrupter	4-38
5	Active line modules with cold plate	5-1
5.1	Description	5-1
5.2	Safety Information	5-1
5.3	Interface description	5-3
5.3.1	Overview	5-3
5.3.2	Connection example	5-4
5.3.3	X1 line connection	5-5
5.3.4	X200-X202 DRIVE-CLiQ interfaces	5-6
5.3.5	EP terminals X21	5-7
5.3.6	X24 24 V terminal adapter	5-8
5.3.7	Meaning of the LEDs on the active line module	5-8
5.4	Dimension Drawing	5-9
5.5	Installing the Cold-Plate Modules on Customer-Specific Heat Sinks	5-10
5.6	Technical Specifications.....	5-13

6	Smart Line Modules (5 kW and 10 kW) with cold plate	6-1
6.1	Description	6-1
6.2	Safety Information	6-1
6.3	Interface description.....	6-3
6.3.1	Overview	6-3
6.3.2	Connection example	6-4
6.3.3	X1 line connection.....	6-5
6.3.4	X21 terminals: smart line module.....	6-6
6.3.5	X22 terminals: smart line module.....	6-7
6.3.6	X24 24 V terminal adapter	6-7
6.3.7	Meaning of the LEDs on the smart line module with cold plate.....	6-8
6.4	Dimension Drawing.....	6-9
6.5	Installation	6-10
6.6	Technical Specifications	6-13
7	Motor Modules with Cold Plate	7-1
7.1	Description	7-1
7.2	Safety Information	7-1
7.3	Interface description.....	7-4
7.3.1	Overview	7-4
7.3.2	Connection Examples	7-5
7.3.3	Motor/brake connection	7-6
7.3.4	X21/X22 EP terminals/temperature sensor connection for motor module with cold plate	7-8
7.3.5	X200-X203 DRIVE-CLiQ interface.....	7-9
7.3.6	Meaning of the LEDs on the motor module	7-9
7.4	Dimension Drawing.....	7-10
7.5	Installation	7-12
7.6	Technical Specifications	7-15
8	Connection adapter	8-1
8.1	Description	8-1
8.2	Safety Information	8-1
8.3	Dimension Drawing.....	8-2
8.4	Installation	8-4
9	Internal Liquid Cooling	9-1
9.1	Cooling system requirements	9-1
9.2	Cooling water requirements	9-2
9.3	Anti-Freeze Additive.....	9-3
9.4	Corrosion Inhibitor Additive (Inhibiting).....	9-4
9.5	Biocide Additive (If Required)	9-4
9.6	Equipotential Bonding	9-4
9.7	Water-to-Water Heat Exchanger.....	9-5
9.8	Air-to-Water Heat Exchanger.....	9-6
9.9	Active Cooling Unit.....	9-7

10	DC link components	10-1
10.1	Braking Module	10-1
10.1.1	Description	10-1
10.1.2	Safety information	10-2
10.1.3	Interface description	10-3
10.1.3.1	Overview	10-3
10.1.3.2	Connection example	10-4
10.1.3.3	Braking resistor connection X1	10-5
10.1.3.4	X21 digital inputs/outputs	10-6
10.1.3.5	Meaning of the LEDs on the braking module	10-7
10.1.4	Dimension drawing	10-8
10.1.5	Installation	10-9
10.1.6	Technical specifications	10-10
10.2	Braking resistors	10-11
10.3	Capacitor Module	10-13
10.3.1	Description	10-13
10.3.2	Safety Information	10-13
10.3.3	Interface description	10-14
10.3.3.1	Overview	10-14
10.3.4	Dimension Drawing	10-15
10.3.5	Installation	10-16
10.3.6	Technical Specifications	10-17
10.4	Control Supply Module	10-17
10.4.1	Description	10-17
10.4.2	Safety Information	10-18
10.4.3	Interface description	10-19
10.4.3.1	Overview	10-19
10.4.3.2	Connection example	10-20
10.4.3.3	Meaning of the LEDs on the control supply module	10-21
10.4.4	Dimension Drawing	10-22
10.4.5	Technical Specifications	10-23
10.5	Voltage Clamping Module (VCM)	10-24
10.5.1	Description	10-24
10.5.2	Safety information	10-25
10.5.3	Interface description	10-26
10.5.3.1	Overview	10-26
10.5.3.2	X1 functional ground	10-27
10.5.4	Dimension drawing	10-28
10.5.5	Installation	10-29
10.5.6	Technical specifications	10-29
11	Options	11-1
11.1	Shielded terminal plates	11-1
11.1.1	Description	11-1
11.1.2	Overview	11-2
11.1.3	Dimension Drawings	11-3
11.1.4	Installation	11-7
11.1.5	Electrical Connection	11-10

11.2	DC link supply adapter	11-12
11.2.1	Description	11-12
11.2.2	Safety Information	11-13
11.2.3	Interface description	11-14
11.2.3.1	Overview	11-14
11.2.3.2	DC link connection	11-15
11.2.4	Dimension Drawings	11-16
11.2.5	Installation	11-18
11.2.6	Electrical Connection	11-20
11.3	DC link adapter	11-21
11.3.1	Description	11-21
11.3.2	Safety Information	11-21
11.3.3	Interface description	11-22
11.3.3.1	Overview	11-22
11.3.3.2	DC link connection	11-23
11.3.4	Dimension Drawing	11-24
11.3.5	Installation	11-25
11.3.6	Electrical Connection	11-26
11.4	DRIVE-CLiQ Flanged Coupling	11-27
11.4.1	Description	11-27
11.4.2	Safety information	11-27
11.4.3	Interface Description	11-28
11.4.3.1	Overview	11-28
11.4.4	Dimension drawing	11-29
11.4.5	Installation	11-31
11.4.6	Technical specifications	11-32
11.5	DRIVE-CLiQ Coupling	11-32
11.5.1	Description	11-32
11.5.2	Safety information	11-32
11.5.3	Interface Description	11-33
11.5.3.1	Overview	11-33
11.5.4	Dimension drawing	11-33
11.5.5	Installation	11-34
11.5.6	Technical specifications	11-34
12	Cabinet Design and EMC	12-1
12.1	Information	12-1
12.1.1	General	12-1
12.1.2	Safety Information	12-2
12.1.3	Directives and Standards	12-3
12.2	Selection of Devices Required for Operating SINAMICS	12-5
12.2.1	General	12-5
12.2.2	Information About Line Disconnecting Devices	12-5
12.2.3	Overcurrent Protection by Means of Line Fuses or Circuit-Breakers	12-6
12.2.4	Line Contactors	12-7
12.3	24 V DC Supply Voltage	12-8
12.3.1	General	12-8
12.3.2	Selecting Power Supply Units	12-9
12.3.3	Typical 24 V Component Current Consumption	12-10
12.3.4	Overcurrent Protection	12-11

Table of contents

12.4	Arrangement of Components and Equipment	12-14
12.4.1	General.....	12-14
12.4.2	Drive Line-Up	12-14
12.4.3	Three-tier configuration	12-18
12.4.4	Connecting the Cooling Water	12-19
12.5	Electromagnetic Compatibility	12-20
12.5.1	General.....	12-20
12.5.2	Cable Shielding and Routing.....	12-21
12.5.3	Equipotential Bonding	12-24
12.6	Connection methods	12-25
12.6.1	Spring-Loaded Terminals/Screw Terminals.....	12-25
12.6.2	Motor connector	12-27
12.6.3	Power connector (X1/X2).....	12-29
12.6.4	24-V terminal adapter.....	12-31
12.7	Cooling	12-32
12.7.1	General.....	12-32
12.7.2	Ventilation.....	12-33
12.7.3	Anti-Condensation Measures.....	12-34
12.7.4	Power Loss of Components in Rated Operation	12-35
13	Service and Maintenance	13-1
13.1	Replacing Components with Internal Liquid Cooling (in Preparation)	13-1
A	Spring-Loaded Terminals/Screw Terminals	A-1
B	List of Abbreviations	B-1
C	References	C-1
	Index	

Description

1.1 Cold-plate cooling

Cold-plate cooling is a cooling method for SINAMICS S120 booksize power sections. On the rear of the device is a flat aluminum cold plate, which acts as a thermal interface.

There are three methods of cooling the SINAMICS power sections:

1. Cold plate with internal liquid cooling (in preparation)

Liquid cooling via a connection adapter, whereby the liquid is conveyed through integrated channels in the cold plate.

2. Cold plate with external air heat sink

The components in the drive line-up are normally all screwed onto heat sink fins outside the cabinet.

3. Cold plate with external liquid heat sink

The components in the drive line-up are normally all screwed onto a liquid heat sink outside the cabinet.

Benefits of cold-plate cooling

1. Particularly suitable for machine configurations involving a high degree of contamination in the vicinity of the machine (e.g. in the textiles or timber industry). Reducing cabinet-internal thermal losses facilitates cooling within a sealed cabinet (IP54).
2. Particularly suitable for machine configurations in which liquid is already used for in-process cooling. This cooling method is also suitable for internal/external cold-plate cooling for the power components. The cooling liquid must have certain properties (see "Cooling Medium").

1.1 Cold-plate cooling

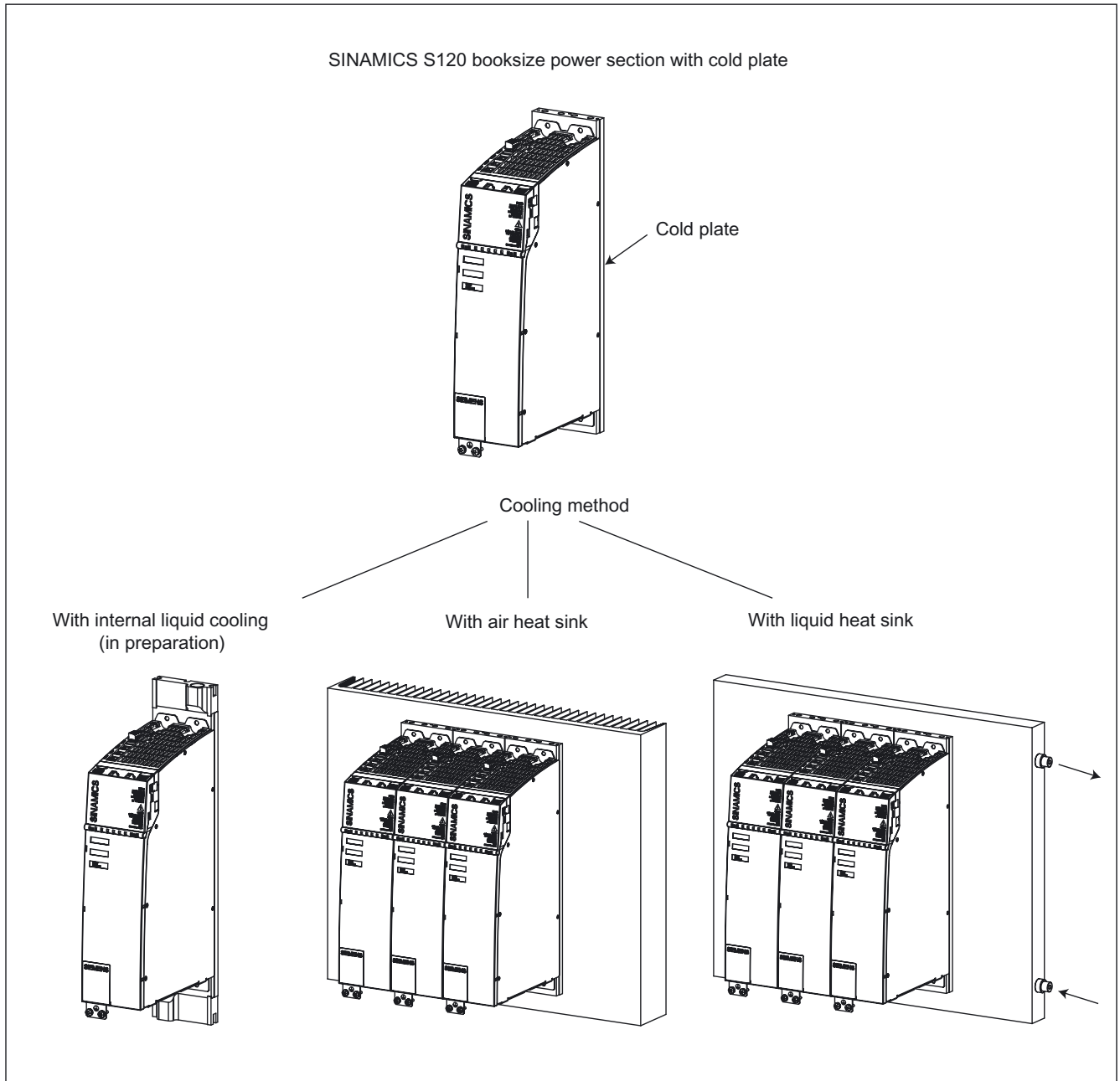

Figure 1-1 Overview: Cold-Plate

1.2 System Data

Technical Specifications

Unless explicitly specified otherwise, the following technical specifications are valid for components of the SINAMICS S120 booksize drive system.

Electrical specifications	
Line connection voltage	3 AC 380 V to 480 V $\pm 10\%$ (-15 % < 1 min)
Line frequency	47 – 63 Hz
Electronics power supply	24 V DC, -15/+20 %*
Conducted radio interference <ul style="list-style-type: none"> • Standard • With line filter 	No conducted radio interference Class A1 to EN 55011
Overvoltage category	Class III to EN 60 664-1

* If a motor holding brake is used, restricted voltage tolerances may have to be taken into account.

Modules	
Line Modules in booksize format <ul style="list-style-type: none"> • Rated supply voltage 	3AC 380 V
Active Line Modules in booksize format <ul style="list-style-type: none"> • Rated pulse frequency 	8 kHz
Motor Modules in booksize format <ul style="list-style-type: none"> • DC link connection voltage • Rated pulse frequency 	510 V DC to 750 V DC 4 kHz

Ambient conditions	
The Safety-Integrated safety function: The components must be protected against conducted contamination (e.g. by installing them in a cabinet with degree of protection IP54). Provided that conducted interference can be prevented at the installation site, the degree of protection for the cabinet can be decreased accordingly.	
Degree of protection	IP20 to EN 60 529
Protection class	Class I (with protective conductor system) and Class III (PELV) to EN 61 800-5-1
Permissible ambient and coolant temperature (air) during operation for line-side components, Line Modules and Motor Modules	0 °C to 40 °C without derating, >40 °C to +55 °C (see derating characteristics)
Permissible ambient and coolant temperature (air) during operation for DC link components	0 °C to +55 °C

Description

1.2 System Data

Information on storage, transportation and operation:	
Environmental class <ul style="list-style-type: none"> • Storage • Transportation • Operation 	Class 1C2 to EN 60 721-3-1 Class 2C2 to EN 60 721-3-2 Class 3C2 to EN 60 721-3-3
Organic/biological influences <ul style="list-style-type: none"> • Storage • Transportation • Operation 	Class 1B1 to EN 60 721-3-1 Class 2B1 to EN 60 721-3-2 Class 3B1 to EN 60 721-3-3
Vibratory load <ul style="list-style-type: none"> • Transportation • Operation 	EN 60 721-3-2, class 2M3 EN 60 721-3-3, class 3M4
Shock load <ul style="list-style-type: none"> • Transportation • Operation 	EN 60 721-3-2, class 2M3 EN 60 721-3-3, class 3M3
Climatic ambient conditions <ul style="list-style-type: none"> • Storage • Transportation • Operation 	Class 1K3 to EN 60 721-3-1 Temperature: -40 °C to +70 °C Class 2K4 to EN 60 721-3-2 Temperature: -40 °C to +70 °C Max. humidity: 95 % at 40 °C Class 3K3 to EN 60 721-3-3 Relative air humidity 5 to 65 % (annual average, ≤ 80 % above the maximum for 2 months a year. Avoid splashing water and do not allow condensation or ice to form (EN 60 204, Part 1)
Degree of contamination	2 to EN 60 664-1
Installation altitude	Up to 1,000 m above sea level without derating, >1,000 m to 5,000 m above sea level (see derating characteristics)

Approbation	
Certification	CE (low-voltage and EMC Directives), cULus (file pos.: E192450, E164110, E70122, and E214113)

Cold plate with external air heat sinks

2.1 Overview

This chapter provides a number of examples to illustrate various cooling methods with external heat sinks that are screwed onto the cold plate.

The following cooling methods are available:

- Air cooling by means of ribbed heat sink
- Liquid cooling by means of liquid heat sink

2.2 Example: cold plate with external air heat sink

2.2.1 Setup

This chapter describes the conditions that you must take into account when setting up the cold plate and external air heat sink.

General conditions to be observed:

1. The maximum temperature within the cabinet is 40 °C (inlet air temperature of the power sections). The maximum temperature within the cabinet during derating is 55 °C. For the specifications, see the "Technical Specifications".
2. The maximum permissible heat sink temperature is module dependent. See the "Technical Specifications". A temperature sensor in the power section measures the temperature and can be read via parameter r0037.

Note

If the components are installed in a sealed cabinet, an internal fan must be installed to prevent hot spots. It is best to install the fan above the modules to optimize the air flow (suction).

If the conditions in the plant do not allow the temperature in the cabinet to be limited to a maximum of 40 °C, further measures must be taken. Please contact the hotline for more information (see the Foreword).

The power sections must be arranged in such a way that the power (loss) is distributed equally. (The permissible current carrying capacities of the DC link busbars in the different modules must be taken into account; see "Technical Specifications".)

2.2.2 Sample setup: cold plate with external air heat sink

This chapter provides an example to illustrate the setup of a cabinet drive line-up in which the power sections are cooled by means of a cold plate with an external air heat sink.

Example:

Four single motor modules and a control supply module are installed next to a line module with 36 kW. Each power section and its cold plate are screwed onto the external air heat sink.

Front view of cabinet

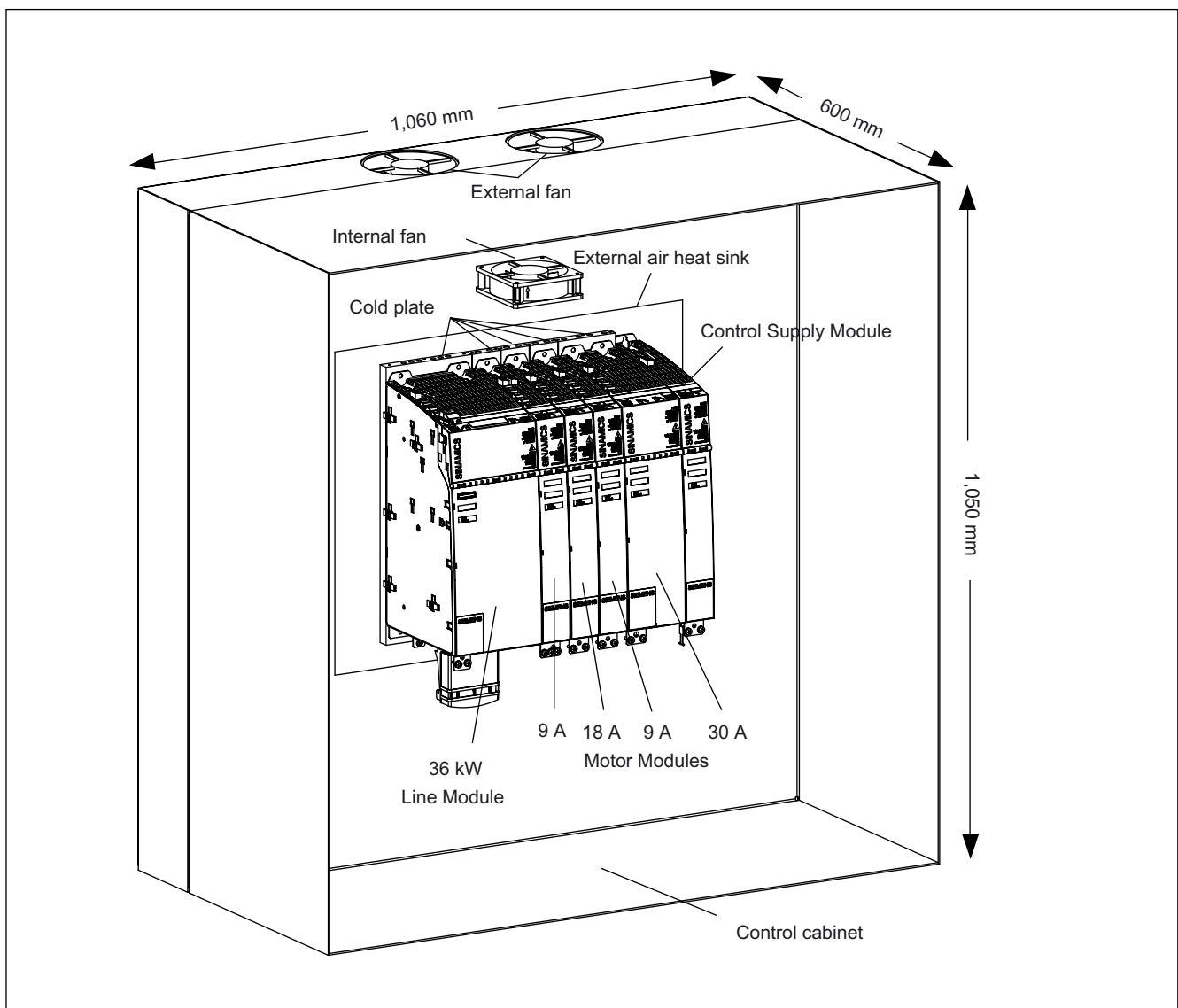

Figure 2-1 Example: cabinet setup with powers ections, cold plate, and external air heat sink

In the cabinet, a fan is installed above the power sections. To optimize usage of the external air heat sink, it is best to arrange the components in such a way that the heat is dissipated equally over the surface of the external heat sink. This means that, if possible, a large power section should be situated next to a smaller one. The current carrying capacity of the DC link busbars must be taken into account here.

Rear view of cabinet

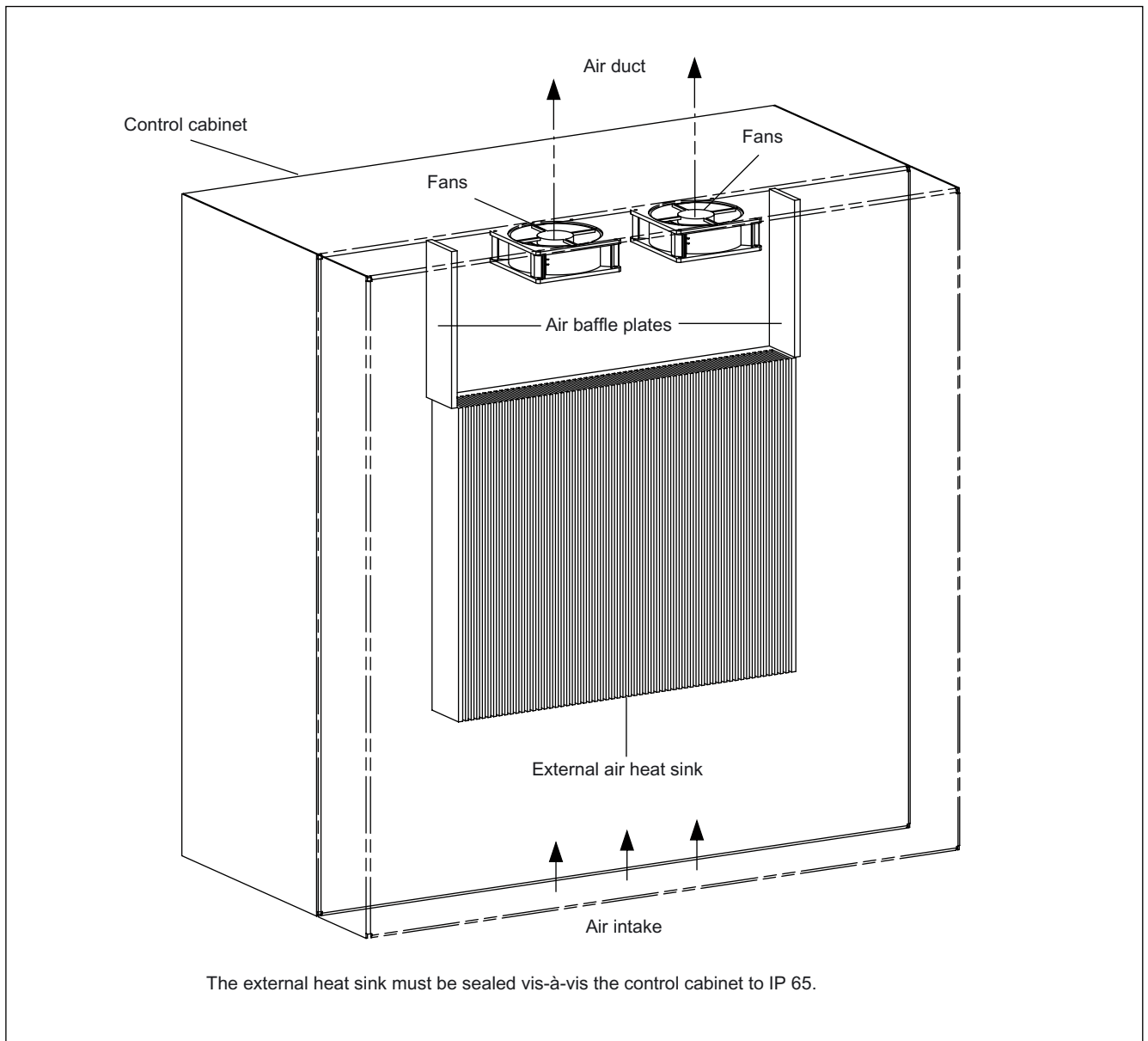

Figure 2-2 Rear view of cabinet

In this example, two axial fans with a diameter of 150 mm ensure forced convection. The ribbed heat sink, which is attached to the rear, is located in an air duct (approx. 150 mm deep). Additional air guides on the sides improve air guidance and significantly optimize the cooling process for the power sections.

Example: external air heat sink

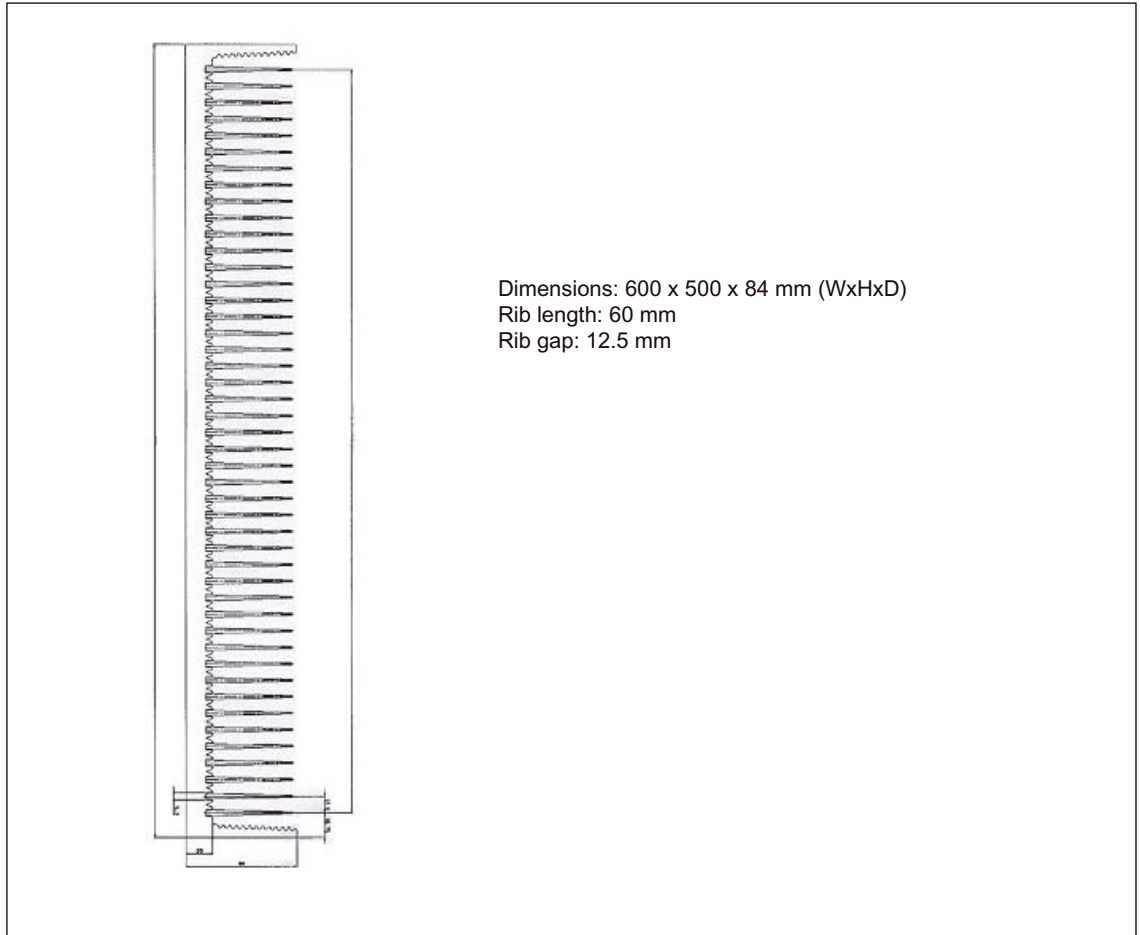

Figure 2-3 Example: air heat sink

Aluminum air heat sinks are recommended.

The heat sinks and fans must be dimensioned for the power loss to be dissipated. For the module-specific power loss in rated operation, see the "Technical Specifications". (Mean power loss in periodic duty is lower.)

The heat sinks and fans are not part of the scope of supply.

Recommended suppliers for heat sinks include:

Alcan, Singen: <http://www.alcan.com>

Sykatec, Erlangen: <http://www.sykatec.de>

Note

The mounting surface for the heat sink (roughness, evenness) must fulfill the requirements described in "Installing External Heat Sinks".

2.3 Example: cold plate with external liquid heat sink

2.3.1 Setup

When an external liquid heat sink is used, the power sections are all mounted on a plate through which cooling water flows to cool the power sections. The size of the liquid heat sink can be adjusted in line with the size of the drive line-up.

General conditions to be observed

1. The maximum temperature within the cabinet is 40 °C (inlet air temperature of the power sections). The maximum temperature within the cabinet during derating is 55 °C. For the specifications, see the "Technical Specifications".
2. The maximum permissible heat sink temperature is module dependent. See the "Technical Specifications". A temperature sensor in the power section measures the temperature and can be read via parameter r0037.

2.3.2 Sample setup: cold plate with external liquid heat sink

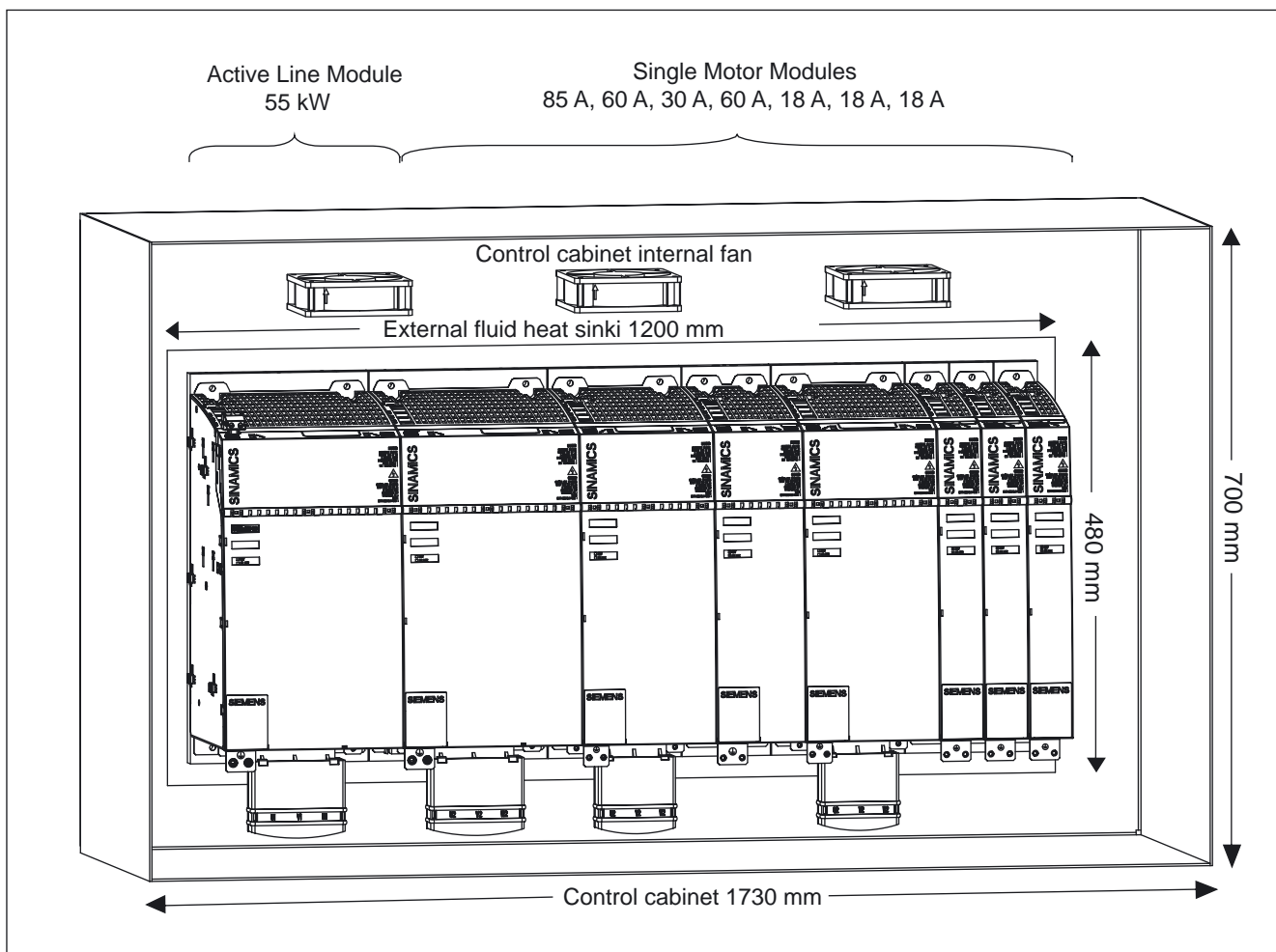

Figure 2-4 Example: cold plate drive line-up with external liquid cooling

Setup:

- Supply: Active line module 55 kW
- 7 single motor modules
- 3 internal fans at the top of the cabinet
- A joint external liquid heat sink (1200 mm x 480 mm)

The heat sinks and fans are not part of the scope of supply.
Recommended suppliers of liquid heat sinks include:
DAU Ges.m.b.H. & CO.KG, Ligist: <http://www.dau-at.com>

Cold plate with internal liquid cooling

3.1 Principle of internal liquid cooling

With internal cold-plate liquid cooling, connectors ("connection adapters") are required directly on the cold plate for connecting the water supply.

Version:

Inlet below, outlet above

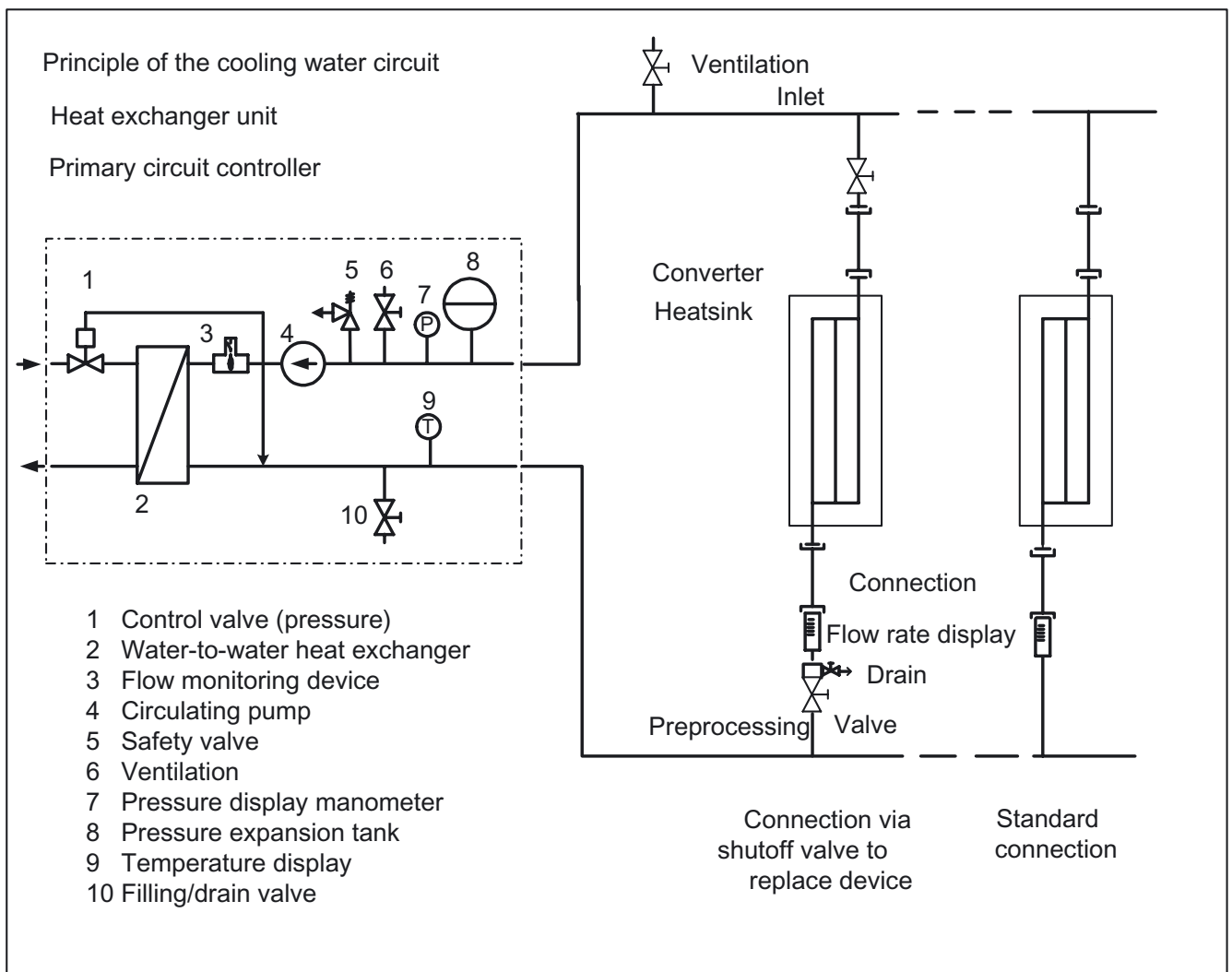

Figure 3-1 Principle of the cooling water circuit

Line Connection

4.1 Introduction

The line connection for a SINAMICS booksize drive line-up comprises an optional line filter and a line reactor:

- Line filter variants:
 - Basic Line Filter for Active Line Modules
 - Wideband Line Filter for Active Line Modules
 - Line filters for Smart Line Modules
- Line reactor variants:
 - Line reactors for Active Line Modules
 - Line reactors for Smart Line Modules

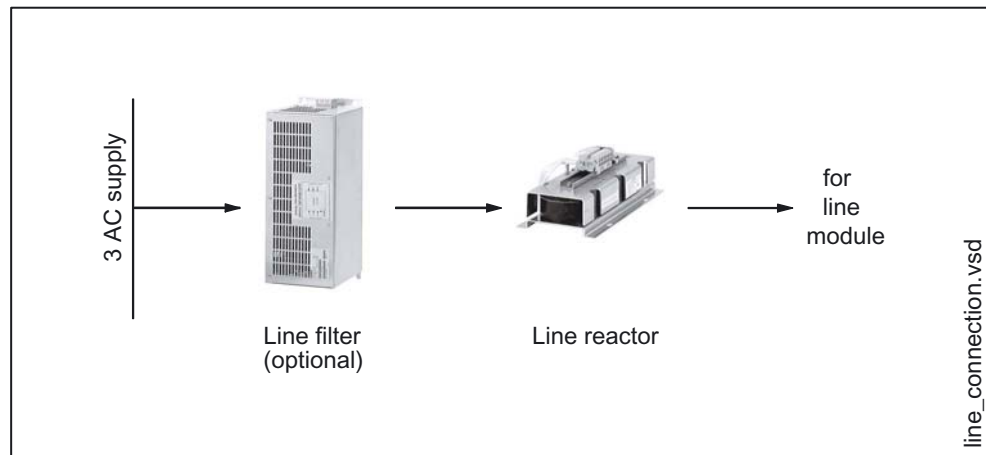

Figure 4-1 Overview diagram: line connection

Note

The limit values for the radio interference voltage are only observed when a line filter is used (class A1 to EN 55011).

Caution

The following can occur if line filters are used that have not been approved for SINAMICS by SIEMENS:

- The Line Modules may become damaged/faulty.
 - Line reactions can occur that can damage or interfere with other loads powered from the same network.
-

4.2 Overview: line filter

In conjunction with a line reactor and an EMC-compliant plant configuration, line filters limit the electromagnetic emissions from the Power Modules to the limit values of class A1 to EN 55011.

Optional line filter rows that are coordinated with the power range are also available with the SINAMICS S120 converter system. These line filters differ with regard to the frequency range in which they reduce the conducted emissions.

Basic Line Filter for Active Line Modules

Basic Line Filters operate in the frequency range from 150 kHz to 30 MHz. Above all, this protects the radio services.

Wideband Line Filter for Active Line Modules

Wideband Line Filters also operate in the frequency range from 2 kHz to 150 kHz. They help reduce low-frequency line reactions, which protects consumers (e.g. electronic devices) against functional impairments and damage when they are operated on the same network.

Line filters for Smart Line Modules

Line filters for Smart Line Modules operate in the frequency range from 150 kHz to 30 MHz. Above all, this protects the radio services.

Table 4-1 Overview

	Order number
Basic Line Filter for Active Line Modules	
16 kW	6SL3000-0BE21-6DAx
36 kW	6SL3000-0BE23-6DAx
55 kW	6SL3000-0BE25-5DA0
Wideband Line Filter for Active Line Modules	
16 kW	3SL3000-0BE21-6AAx
36 kW	3SL3000-0BE23-6AAx
55 kW	3SL3000-0BE25-5AAx
80 kW	3SL3000-0BE28-0AAx
120 kW	3SL3000-0BE31-2AAx
Line filters for Smart Line Modules	
5 kW	6SL3000-0HE15-0AAx
10 kW	6SL3000-0HE21-0AAx
16 kW	6SL3000-0BE21-6DAx
36 kW	6SL3000-0BE23-6DAx

4.3 Basic Line Filter for Active Line Modules

4.3.1 Description

The Basic Line Filters for Active Line Modules are designed for use in machines in which the conducted interference in the frequency range is to be reduced in accordance with EMC regulations. The machine manufacturer must carry out EMC-compliant CE certification for the product before it is implemented.

General conditions regarding Basic Line Filters for Active Line Modules

The firm that puts the machine on the market takes full responsibility for ensuring CE EMC conformity and that the Basic Line Filter is used correctly. The machine manufacturer (OEM) must have the machine conformity confirmed.

The Basic Line Filters can be used in accordance with the following general conditions for ensuring CE conformity with regard to conducted interference:

- The machine/system must only be used in industrial networks.
- No. of axes <12.
- Total cable lengths <150 m (motor cables, power supply cable between line filter and Line Module).

4.3.2 Safety information



Caution

Line filters are only suitable for direct connection to TN systems.



Danger

The 100 mm clearances above and below the components must be observed. The mounting position must ensure that cool air flows vertically through the filter. This measure prevents thermal overloading of the filter.

Caution

The terminals must be correctly connected:

Incoming line cable to LINE/NETZ L1, L2, L3

Outgoing cable to line reactor on LOAD/LAST L1', L2', L3'.

Non-observance may damage the line filter.



Caution

The line filters listed conduct a high leakage current via the PE conductor. Because of the high leakage current of the line filters, a permanent PE connection of the line filter or switching cabinet is required.

Measures according to EN 61800-5-1 must be taken (e.g. PE conductor ($\geq 10\text{mm}^2$ Cu) or fit an additional connection terminal for a PE conductor with the same cross-section as the original PE conductor).



Warning

A hazardous voltage will be present at the terminals for a further 5 minutes after the system has been shutdown.

Note

If a high-potential test is conducted with alternating voltage in the system, the line filters must be disconnected to obtain correct measurement results.

Caution

Only the line filters described in this Equipment Manual must be used. Other line filters can lead to line harmonics that can interfere with or damage other loads powered from the network.

4.3.3 Interface description

4.3.3.1 Overview

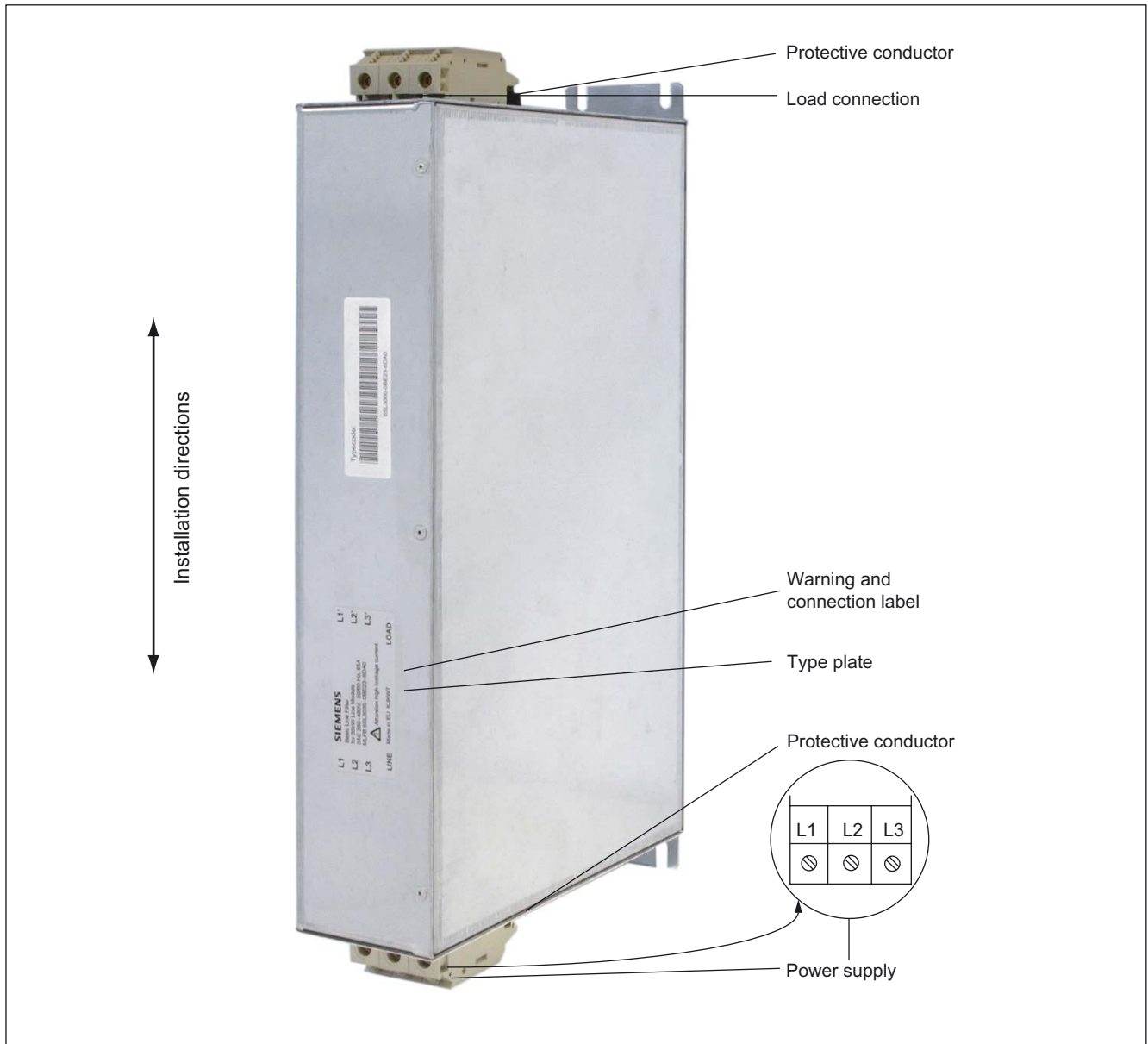

Figure 4-2 Basic Line Filter for Active Line Modules (example: 36 kW)

4.3.3.2 Line/load connection

The Basic Line Filter for Active Line Modules is rated for a voltage range of 380 V 3AC -10% to 480 V 3AC +10% (-15% <1 min) at 47 Hz to 63 Hz.

Table 4-2 Type of connection

Terminals	Designations
Line connection (line)	L1, L2, L3, PE
Load connection (load)	L1', L2', L3', PE
Basic Line Filter for Active Line Modules	
16 kW	Screw terminal: 10 mm ² 3-pin/1.5 Nm (see Screw Terminals) PE connection: M6/3 Nm ¹⁾
36 kW	Screw terminal: 35 mm ² PE connection: M6/3 Nm ¹⁾
55 kW	Screw terminal: 50 mm ² PE connection: M6/3 Nm ¹⁾
1) for ring cable lugs to DIN 46234	

4.3.4 Dimension Drawing

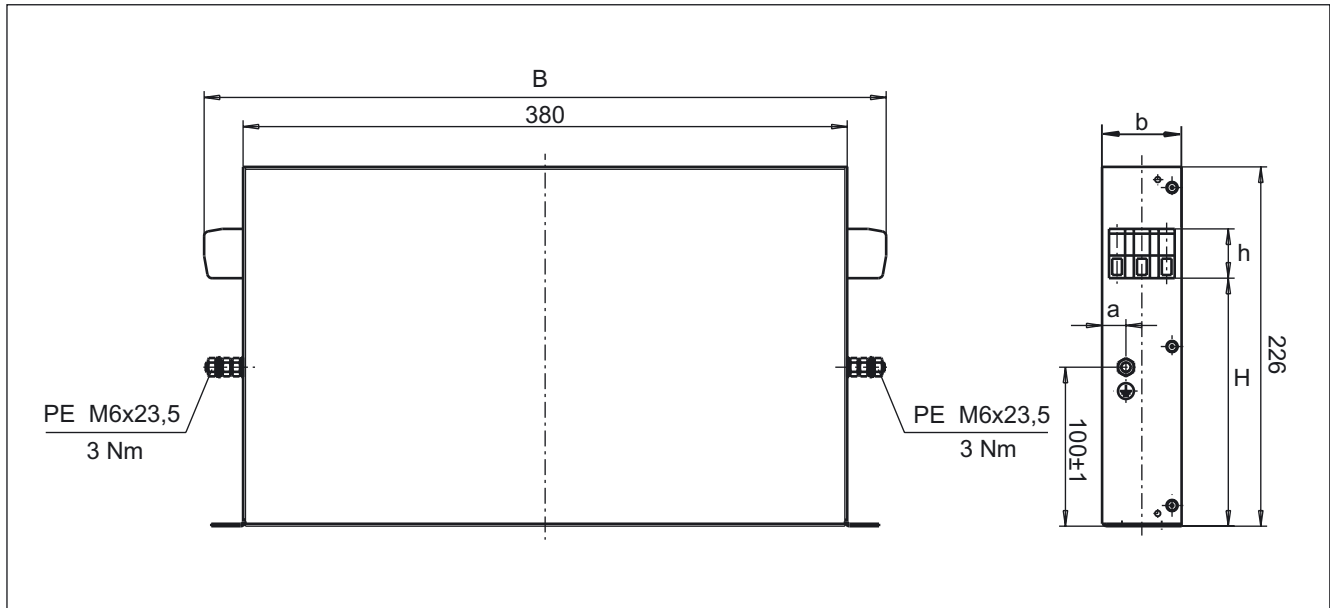

Figure 4-3 Dimension drawing: Basic Line Filter for Active Line Modules (16 kW to 55 kW)

Table 4-3 Dimensions: Basic Line Filter for Active Line Modules

Basic Line Filter	Order number	B [mm] (inches)	b [mm] (inches)	a [mm] (inches)	H [mm] (inches)	h [mm] (inches)
16 kW	6SL3000-0BE21-6DAx	429 (16.88)	50 (1.96)	15 (0.59)	156 (6.14)	31 (1.22)
36 kW	6SL3000-0BE23-6DAx	433 (17.07)	75 (2.95)	15 (0.59)	135 (5.31)	68 (2.67)
55 kW	6SL3000-0BE25-5DA0	466 (18.34)	100 (3.93)	15 (0.59)	148 (5.82)	54 (2.12)

4.3.5 Technical Specifications

Table 4-4 Technical specifications: Basic Line Filter for Active Line Modules

	6SL3000 unit	0BE21-6DA0	0BE23-6DA0	0BE25-5DA0
Rated power	kW	16	36	55
Connection voltage: Supply voltage Line frequency	V _{AC} Hz	3AC 380 -10% to 3AC 480 +10% (-15% < 1 min) 47 to 63 Hz		
Rated current	A _{AC}	36	65	105
Power loss ¹	W	16	28	41
Weight	kg	5	6.5	11.5

¹ For an overview, see the power loss tables in Cabinet Design.

4.4 Wideband Line Filter for Active Line Modules

4.4.1 Description

The damping characteristics of Wideband Line Filters for Active Line Modules not only conform with the requirements of EMC standards for the frequency range of 150 kHz to 30 MHz but also include low frequencies as of 2 kHz. As a result, these line filters have an extended function area, which means that they can, to a certain extent, be used regardless of the machine installation location and any unknown line properties (e.g. line impedance).

With these line filters, the limit values in accordance with EN 55011, Class A for devices in group 1 are observed.

The total cable length must be less than 350 m (motor cables, power supply cable between line filter and Line Module).

4.4.2 Safety information



Caution

Line filters are only suitable for direct connection to TN systems.



Danger

The 100 mm clearances above and below the components must be observed. The mounting position must ensure that cool air flows vertically through the filter. This measure prevents thermal overloading of the filter.

Caution

The terminals must be correctly connected:

Incoming line cable to LINE/NETZ L1, L2, L3

Outgoing cable to the line reactor to LOAD/LAST U, V, W

Non-observance may damage the line filter



Caution

The line filters listed conduct a high leakage current via the PE conductor. Because of the high leakage current of the line filters, a permanent PE connection of the line filter or switching cabinet is required.

Measures according to EN 61800-5-1 must be taken (e.g. PE conductor ($\geq 10\text{mm}^2$ Cu) or fit an additional connection terminal for a PE conductor with the same cross-section as the original PE conductor).



Warning

A hazardous voltage will be present at the terminals for a further 5 minutes after the system has been shutdown.

Note

If a high-potential test is conducted with alternating voltage in the system, the line filters must be disconnected to obtain correct measurement results.

Caution

Only the line filters described in this Equipment Manual must be used. Other line filters can lead to line harmonics that can interfere with or damage other loads powered from the network.

4.4.3 Interface description

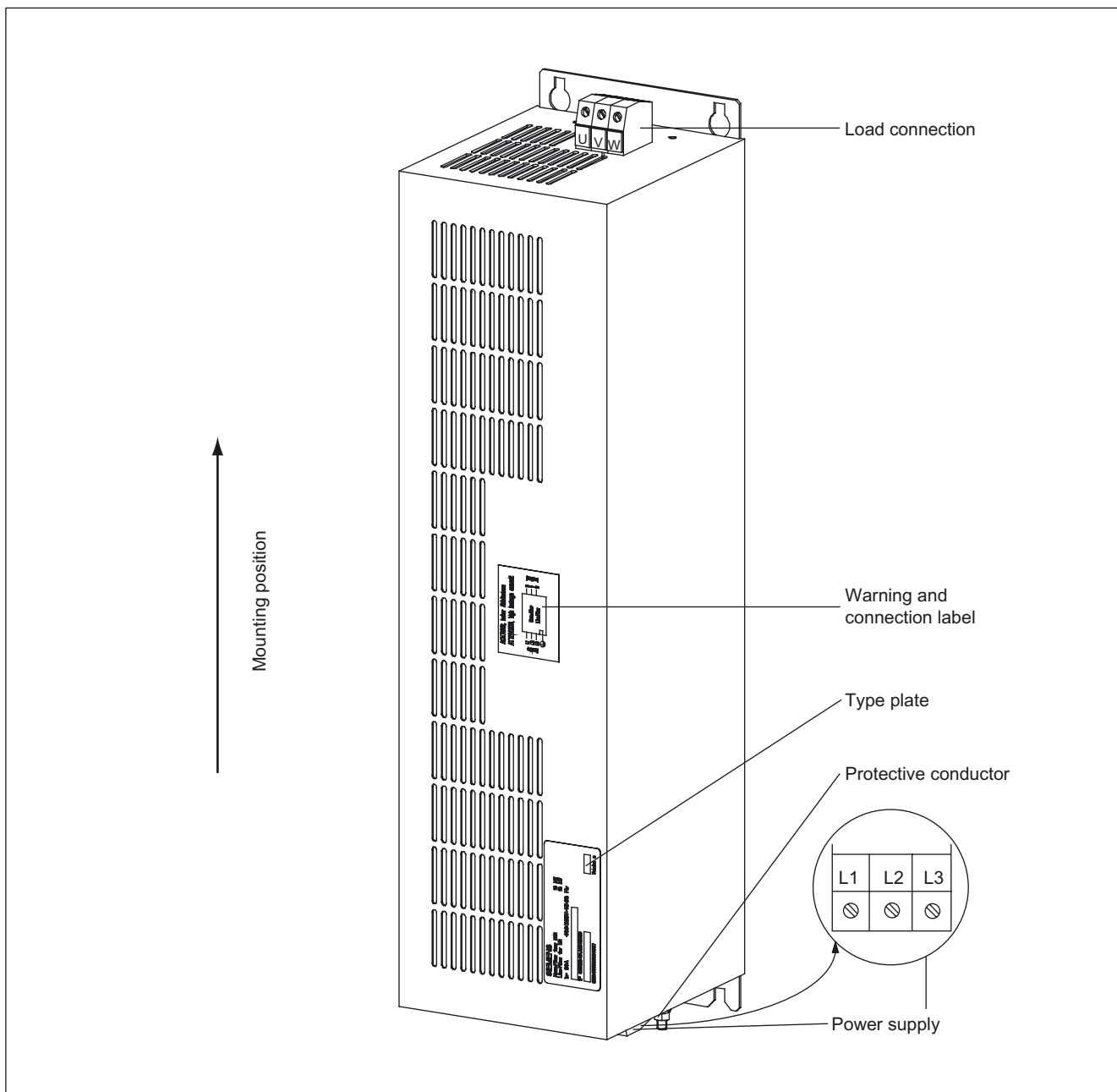

Figure 4-4 Wideband Line Filters for Active Line Module (example: 16 kW)

4.4 Wideband Line Filter for Active Line Modules

4.4.3.1 Line/load connection

A Wideband Line Filter for Active Line Modules is rated for a voltage range of 380 V 3AC -10% to 480 V 3AC +10% (-15% <1 min) at 47 Hz to 63 Hz.

Table 4-5 Type of connection

Terminals	Designations
Line connection (line)	L1, L2, L3, PE
Load connection (load)	U, V, W
Wideband Line Filter for Active Line Modules	
16 kW	Screw terminal: 10 mm ² 3-pin/1.5 Nm (see Screw Terminals) Ground stud: M5/3 Nm ¹⁾
36 and 55 kW	Screw terminal: 50 mm ² 3-pin/6 Nm (see Screw Terminals) Ground stud: M8/13 Nm ¹⁾
80 kW	Screw terminal: 95 mm ² 3-pin/15 Nm (see Screw Terminals) Ground stud: M8/13 Nm ¹⁾
120 kW	Connection strap: d = 11 mm (M10/25 Nm) Ground stud: M8/13 Nm ¹⁾ Note: No shock-hazard protection (IP00)
1) for ring cable lugs to DIN 46234	

4.4.4 Dimension Drawing

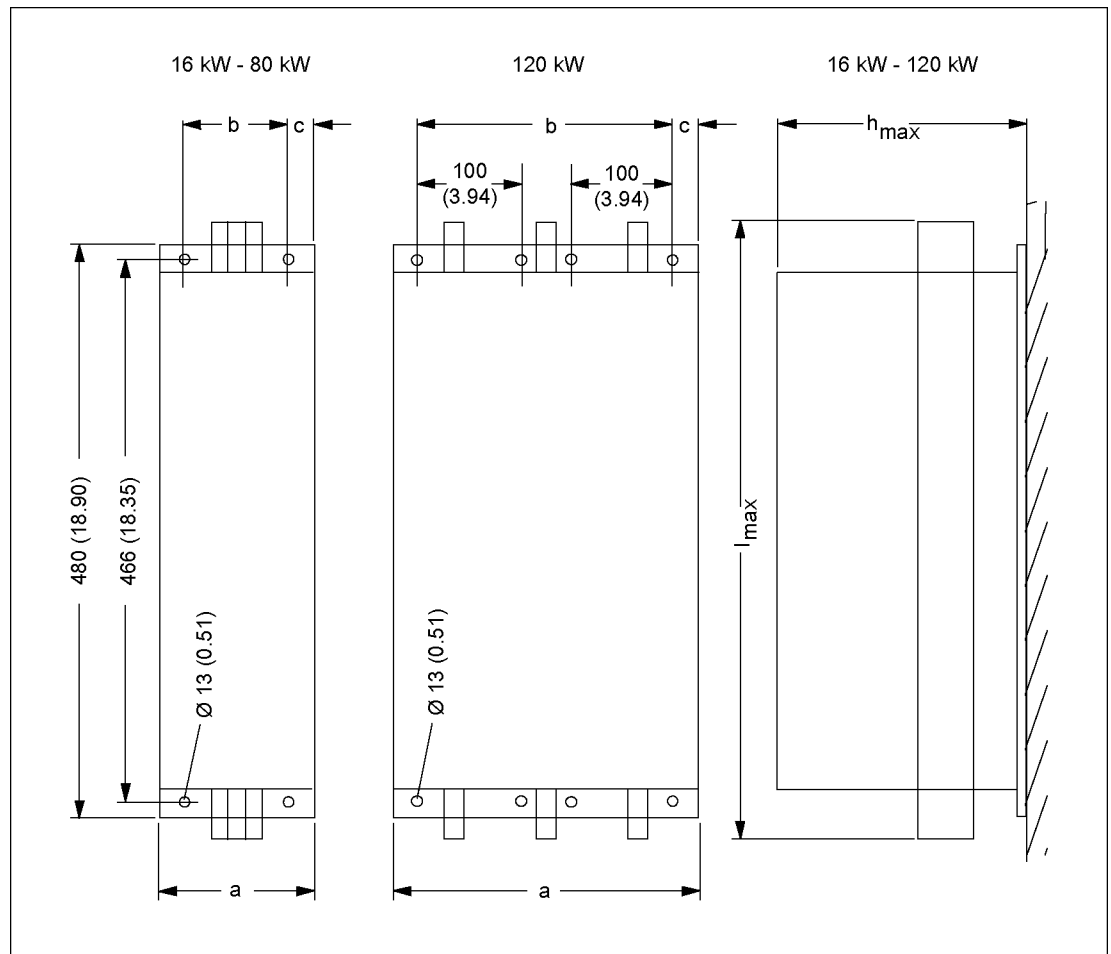

Figure 4-5 Dimension drawing: Wideband Line Filter for Active Line Modules

Table 4-6 Dimensions: Wideband Line Filter

For Active Line Modules	Order number 6SL3000-	a [mm] (inches)	b [mm] (inches)	c [mm] (inches)	h _{max} [mm] (inches)	l _{max} [mm] (inches)
16 kW	0BE-21-6AAx	130 (5.12)	100 (3.94)	15 (0.59)	150 (5.91)	489 (19.25)
36 kW	0BE-23-6AAx	130 (5.12)	100 (3.94)	15 (0.59)	245 (9.65)	526 (20.71)
55 kW	0BE-25-5AAx	130 (5.12)	100 (3.94)	15 (0.59)	260 (10.24)	526 (20.71)
80 kW	0BE-28-0AAx	200 (7.87)	150 (5.91)	25 (0.98)	260 (10.24)	539 (21.22)
120 kW	0BE-31-2AAx	300 (11.81)	250 (9.84)	25 (0.98)	260 (10.24)	530 (20.87)

4.4.5 Technical Specifications

Table 4-7 Technical specifications: Wideband Line Filter for Active Line Modules

	6SL3000 unit	0BE21-6AA0	0BE23-6AA0	0BE25-5AA0	0BE28-0AA0	0BE31-2AA0
Rated power	kW	16	36	55	80	120
Connection voltages: Supply voltage Line frequency	V _{AC} Hz	3AC 380 -10% to 3AC 480 +10% (-15% < 1 min) 47 to 63 Hz				
Rated current	A _{AC}	30	67	103	150	225
Power loss ¹	W	70	90	110	150	200
Weight	kg	9	16	19	22	32

¹ For an overview, see the power loss tables in Cabinet Design.

4.5 Line filters for Smart Line Modules

4.5.1 Description

The line filters for Smart Line Modules are designed for use in machines in which the conducted interference in the frequency range is to be reduced in accordance with EMC regulations. The machine manufacturer must carry out EMC-compliant CE certification for the product before it is implemented.

General conditions regarding line filters for Smart Line Modules

- In conjunction with the line filters and the associated line reactors, drive line-ups with Basic Line Modules fulfill the requirements of limit value class A1 to EN55011.
- Total cable length: ≤ 350 m

4.5.2 Safety information



Caution

Line filters are only suitable for direct connection to TN systems.



Danger

The 100 mm clearances above and below the components must be observed. The mounting position must ensure that cool air flows vertically through the filter. This measure prevents thermal overloading of the filter.

Caution

The terminals must be correctly connected:

Incoming line cable to LINE/NETZ L1, L2, L3

Outgoing cable to line reactor on LOAD/LAST L1', L2', L3'.

Non-observance may damage the line filter.



Caution

The line filters listed conduct a high leakage current via the PE conductor. Because of the high leakage current of the line filters, a permanent PE connection of the line filter or switching cabinet is required.

Measures according to EN 61800-5-1 must be taken (e.g. PE conductor ($\geq 10\text{mm}^2$ Cu) or fit an additional connection terminal for a PE conductor with the same cross-section as the original PE conductor).



Warning

A hazardous voltage will be present at the terminals for a further 5 minutes after the system has been shutdown.

Note

If a high-potential test is conducted with alternating voltage in the system, the line filters must be disconnected to obtain correct measurement results.

Caution

Only the line filters described in this Equipment Manual must be used. Other line filters can lead to line harmonics that can interfere with or damage other loads powered from the network.

4.5.3 Interface description

4.5.3.1 Overview

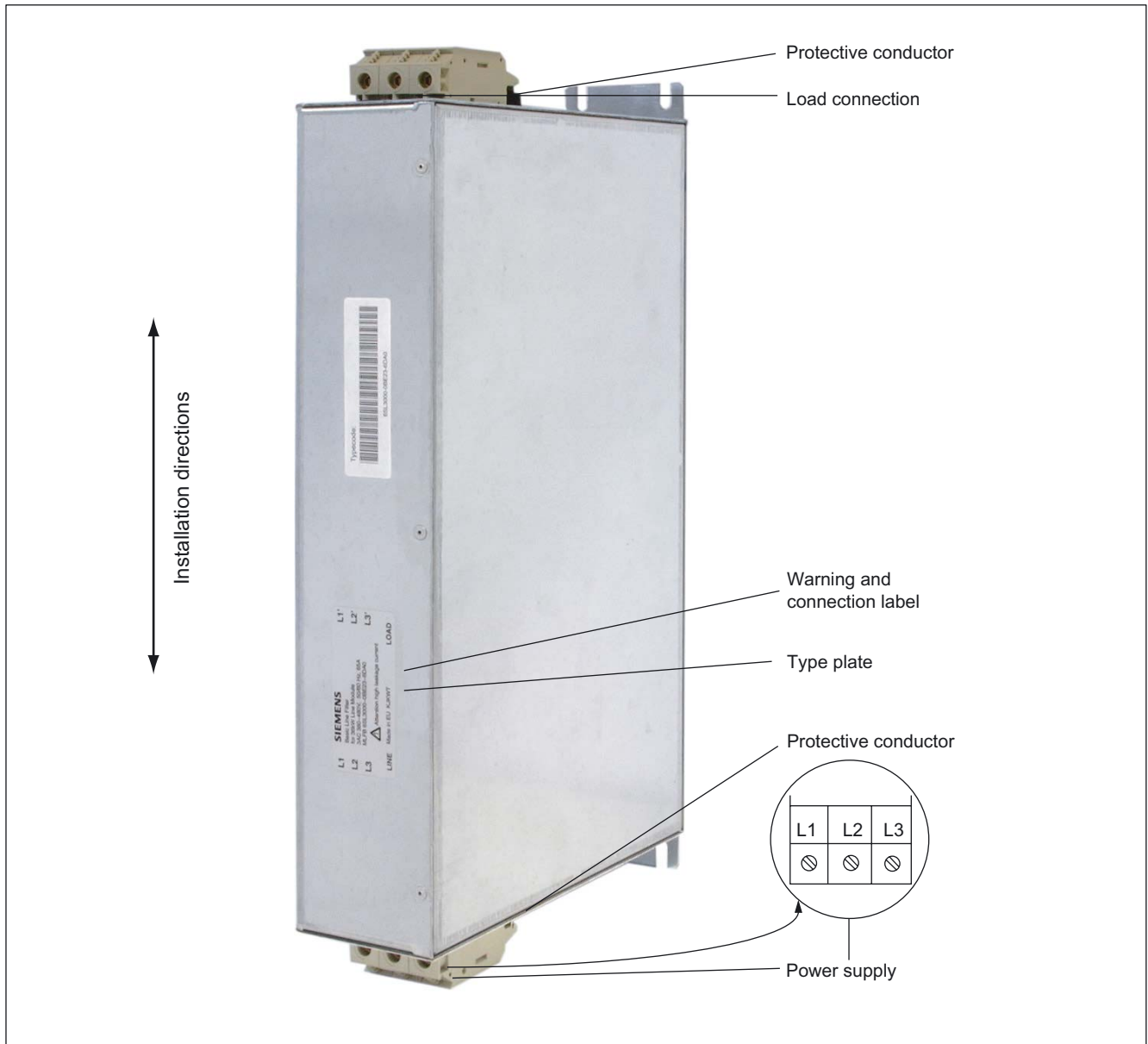

Figure 4-6 Line filters for Smart Line Modules (example: 36 kW)

4.5.3.2 Line/load connection

Line filters for Smart Line Modules are rated for a voltage range from 380 V 3AC -10% to 480 V 3AC +10% (-15% <1 min) at 47 Hz to 63 Hz.

Table 4-8 Type of connection

Terminals	Designations
Line connection (line)	L1, L2, L3, PE
Load connection (load)	L1', L2', L3', PE
Line filters for Smart Line Modules	
5 kW	Screw terminal: 10 mm ² 3-pin/1.5 Nm (see Screw Terminals) Ground stud: M6/4.8 Nm ¹⁾
10 kW	Screw terminal: 10 mm ² 3-pin/1.5 Nm (see Screw Terminals) Ground stud: M6/4.8 Nm ¹⁾
16 kW	Screw terminal: 10 mm ² 3-pin/1.5 Nm (see Screw Terminals) Ground stud: M6/3 Nm ¹⁾
36 kW	Screw terminal: 35 mm ² Ground stud: : M6/3 Nm ¹⁾
1) for ring cable lugs to DIN 46234	

4.5.4 Dimension Drawings

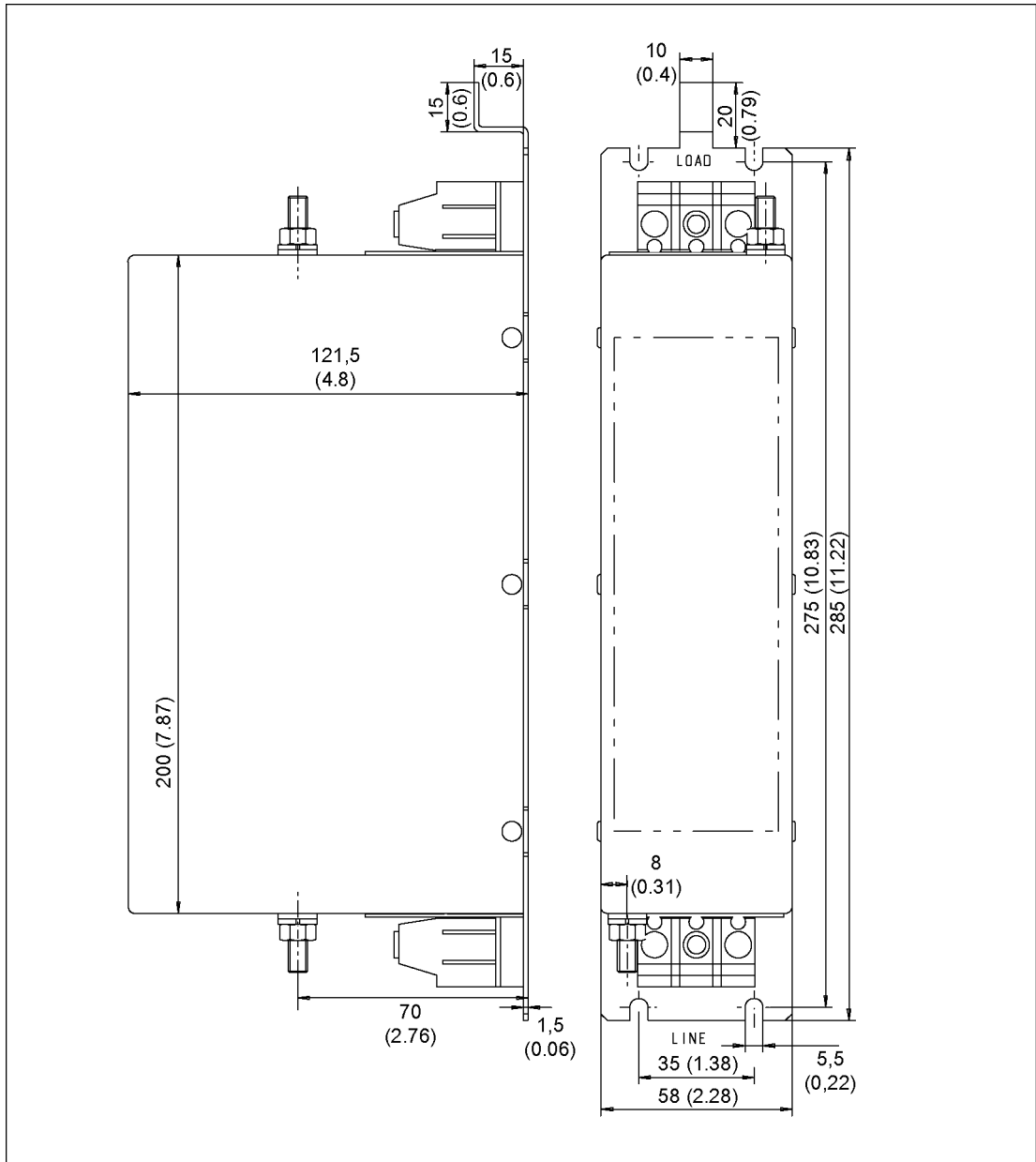

Figure 4-7 Dimension drawing: line filters for Smart Line Modules (5 and 10 kW)

Table 4-9 Line filters for Smart Line Modules

Line filters for Smart Line Modules	Order number
5 kW	6SL3000-0HE15-0AAx
10 kW	6SL3000-0HE21-0AAx

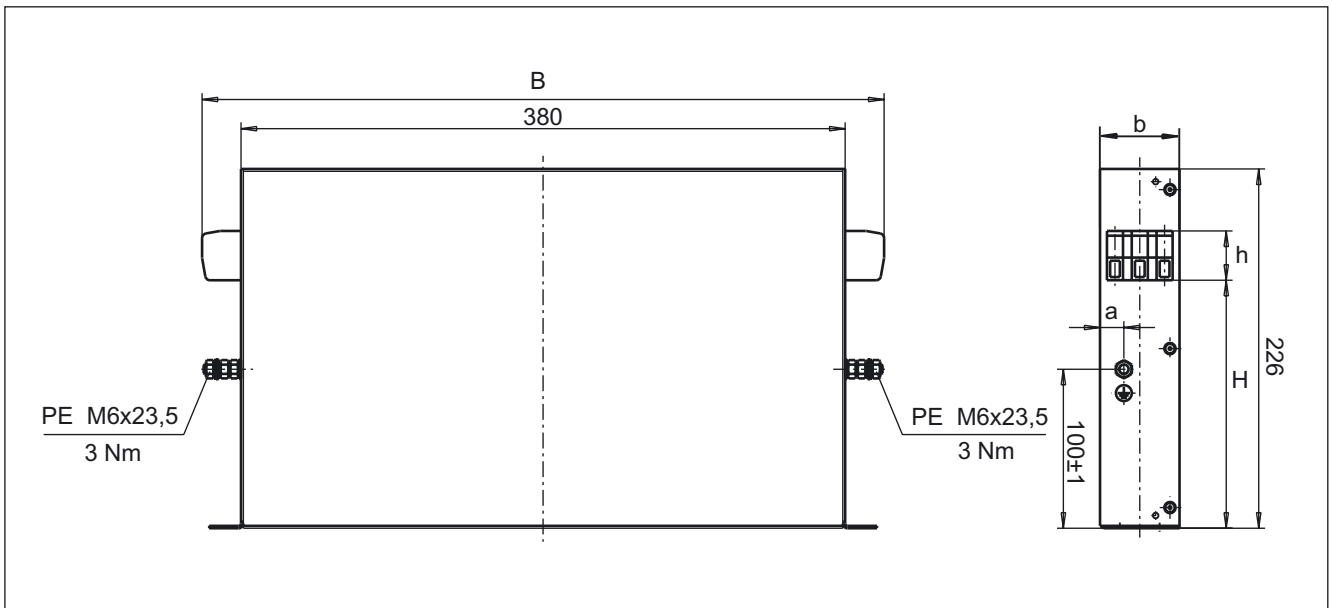

Figure 4-8 Dimension drawing: line filter for Smart Line Module (16 kW and 36 kW)

Table 4-10 Dimensions: line filter for Smart Line Module

Line filters for Smart Line Modules	Order number	B [mm] (inches)	b [mm] (inches)	a [mm] (inches)	H [mm] (inches)	h [mm] (inches)
16 kW	6SL3000-0BE21-6DAx	429 (16.88)	41.3 (1.62)	15 (0.59)	156 (6.14)	31 (1.22)
36 kW	6SL3000-0BE23-6DAx	433 (17.07)	48 (1.88)	15 (0.59)	135 (5.31)	68 (2.67)

4.5.5 Technical Specifications

Table 4-11 Technical specifications of line filters for the Smart Line Module

	6SL3000-unit	0HE15-0AA0	0HE21-0AA0	0BE21-6DA0	0BE23-6DA0
Rated power	kW	5	10	16	36
Connection voltage: Supply voltage Line frequency	V _{AC} Hz	3AC 380 -10% to 3AC 480 +10% (-15% < 1 min) 47 to 63 Hz			
Rated current	A _{AC}	16	25	36	65
Power loss ¹	W	20	20	16	28
Weight	kg	2.1	2.3	5	6.5

¹ For an overview, see the power loss tables in Cabinet Design.

4.6 Line reactors for Active Line Modules

4.6.1 Description

Line reactors limit low-frequency line harmonics to permissible values. In conjunction with Active Line Modules, they are also used to store energy.

4.6.2 Safety information

Caution

A ventilation clearance of 100 mm must be observed around the components apart from to the mounting surface.

Note

The connection cables to the Line Module must be as short as possible (max. 10 m). If possible, they should be shielded. Unless it can otherwise be avoided, cables must be routed past the line reactor at a minimum distance of 150 mm.

Caution

Only the line reactors described in this Equipment Manual must be used. Using line reactors not approved by SIEMENS for SINAMICS 6SL31:

- can damage/destroy Line Modules.
- cause line reactions that can damage or destroy other loads powered from the same network.



Caution

The surface temperature of the line reactors may exceed 80 °C.

4.6.3 Connection description

The line reactor is rated for a voltage range from 380 V 3AC -10% to 480 V 3AC +10% at 47 Hz to 63 Hz.

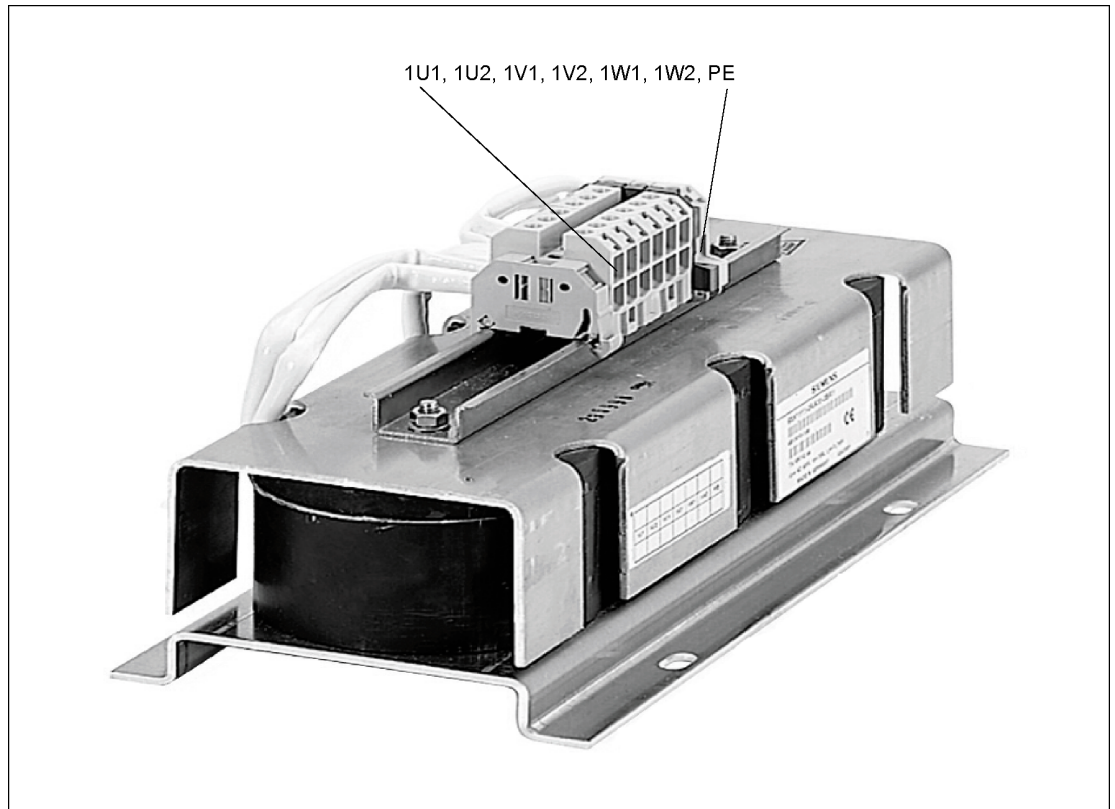

Figure 4-9 Line reactor (example: 16 kW)

4.6 Line reactors for Active Line Modules

4.6.3.1 Line/load connection

Table 4-12 Connection methods for line reactor

Terminals	Designations
Line connection	1U1, 1V1, 1W1, PE
Load connection	1U2, 1V2, 1W2
Line reactors for Active Line Modules	
16 kW	Screw terminal 16 mm ² 3-pin / 6 Nm*
36 kW	Screw terminal 35 mm ² 3-pin / 6 Nm*
55 kW	Screw terminal 70 mm ² 3-pin / 6 Nm*
80 kW	Connection strap d = 9 mm ² (M10/25 Nm) for ring cable lugs to DIN 46234 Note: No shock-hazard protection (IP00)
120 kW	Connection strap d = 10 mm ² (M10/25 Nm) for ring cable lugs to DIN 46234 Note: No shock-hazard protection (IP00)

* See Screw Terminals

4.6.4 Dimension Drawings

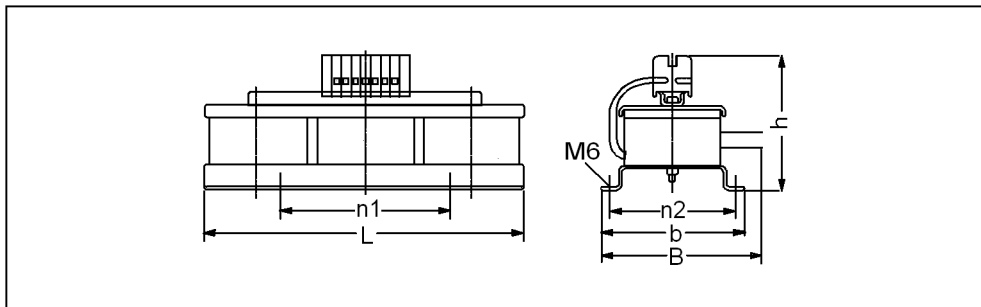

Figure 4-10 Dimension drawing: line reactor for Active Line Modules (up to 55 kW)

Table 4-13 Dimensions of the line reactor for Active Line Modules

	Order number 6SN1111-	L [mm] (inches)	W [mm] (inches)	h [mm] (inches)	b [mm] (inches)	n ₁ [mm] ¹⁾ (inches)	n ₂ [mm] ¹⁾ (inches)
16 kW	0AA00-0BA1	330 (12.99)	150 (5.91)	145 (5.71)	150 (5.91)	175 (6.89)	136 (5.35)
36 kW	0AA00-0CA1	330 (12.99)	150 (5.91)	230 (9.06)	150 (5.91)	175 (6.89)	136 (5.35)
55 kW	0AA00-0DA1	330 (12.99)	150 (5.91)	280 (11.02)	150 (5.91)	175 (6.89)	136 (5.35)

1) Dimensions n₁ and n₂ correspond to the drill hole spacing

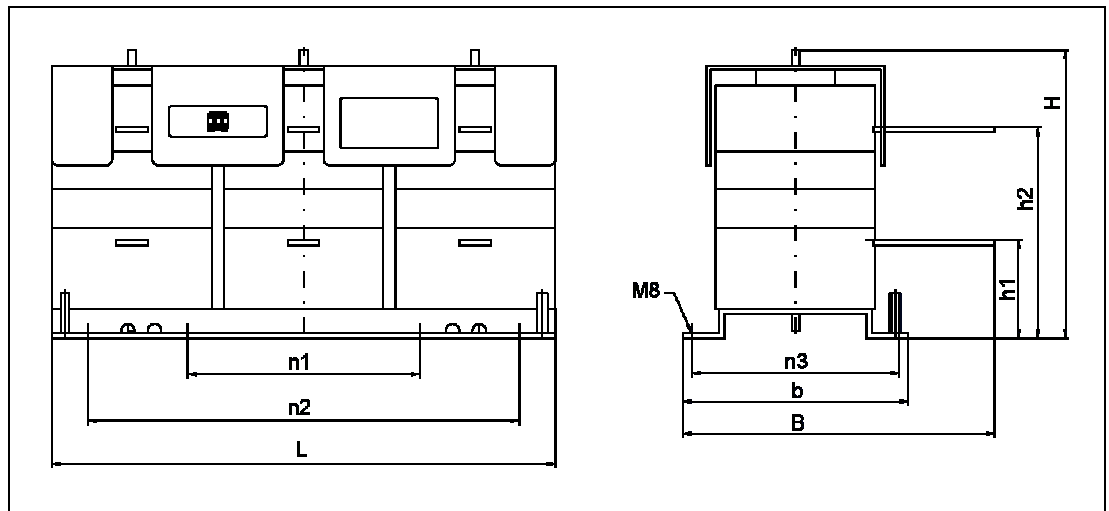

Figure 4-11 Dimension drawing: line reactor for Active Line Modules (as of 80 kW)

Table 4-14 Dimensions of the line reactor for Active Line Modules

	Order number	L [mm] (inches)	W [mm] (inches)	h1 [mm] (inches)	h2 [mm] (inches)	H [mm] (inches)	b [mm] (inches)	n1 [mm] 1) (inches)	n2 [mm] 1) (inches)	n3 [mm] 1) (inches)
80 kW	6SN1111-0AA00-1EA0	380 (14.96)	225 (8.86)	50 (1.70)	170 (6.69)	220 (8.66)	170 (6.69)	175 (6.89)	325 (12.80)	156 (6.14)
120 kW	6SL3000-0DE31-2BA0	490 (19.29)	225 (8.86)	60 (2.36)	220 (8.66)	250 (9.84)	170 (6.69)	175 (6.89)	325 (12.80)	156 (6.14)

1) The lengths n1, n2 and n3 correspond to the drill hole spacing

4.6.5 Technical specifications

Table 4-15 Technical specifications of line reactors for the Active Line Module

	6SN1111- Unit	0BA1	0CA1	0DA1	1EA0	1FA0
Output	kW	16	36	55	80	120
Rated current	A_{rms}	30	67	103	150	225
Power loss ¹	W	170	250	350	450	590
Weight	Weight[kg]	8.5	13	18	40	50

¹ For an overview, see the power loss tables in Cabinet Design.

4.7 Line reactors for Smart Line Modules

4.7.1 Description

Line reactors for Smart Line Modules limit low-frequency line harmonics to permissible values.

4.7.2 Safety information

Caution

A ventilation clearance of 100 mm must be observed around the components apart from to the mounting surface.

Note

The connection cables to the Line Module must be as short as possible (max. 10 m). If possible, they should be shielded. Unless it can otherwise be avoided, cables must be routed past the line reactor at a minimum distance of 150 mm.

Caution

Only the line reactors described in this Equipment Manual must be used.

Using line reactors not approved by SIEMENS for SINAMICS 6SL31:

- can damage/destroy Line Modules.
 - cause line reactions that can damage or destroy other loads powered from the same network.
-



Caution

The surface temperature of the line reactors may exceed 80 °C.

4.7.3 Connection description

4.7.3.1 Overview

The line reactor is rated for a voltage range from 380 V 3AC -10% to 480 V 3AC +10% at 47 Hz to 63 Hz.

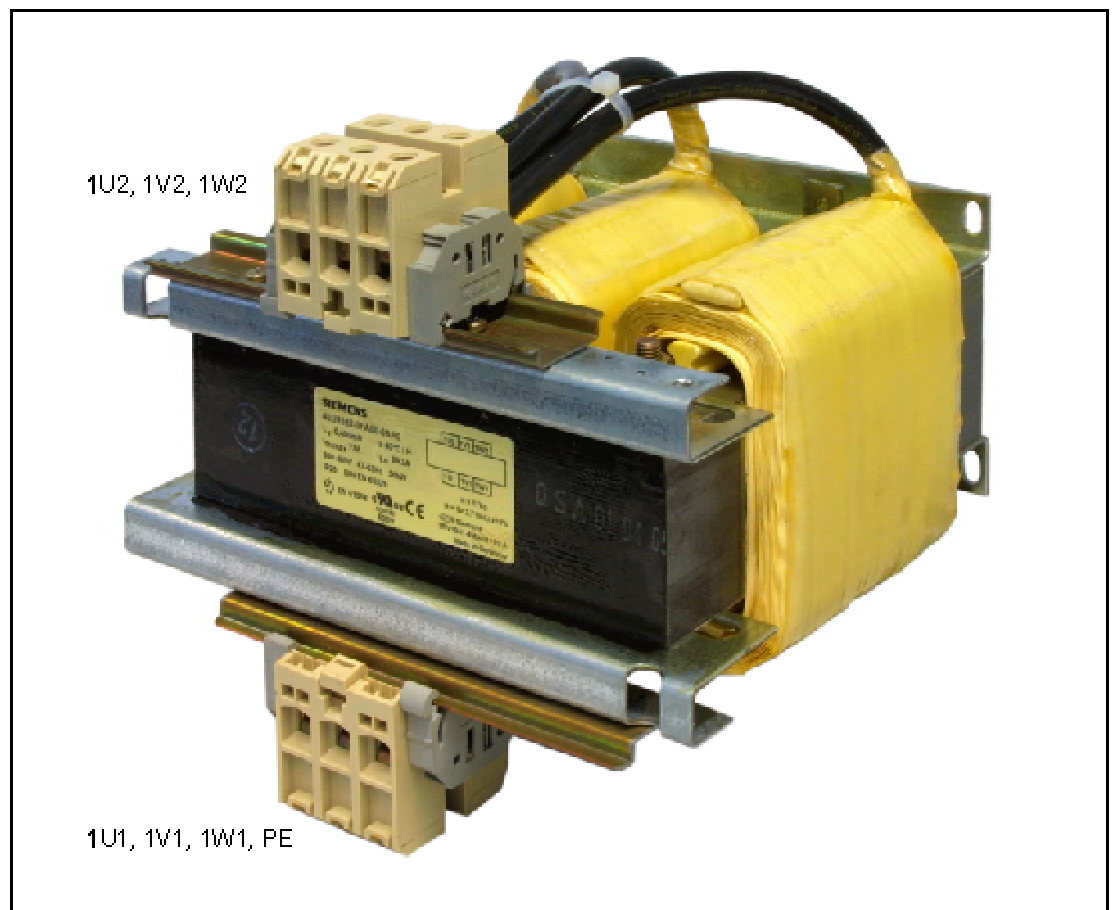

Figure 4-12 Line reactors for Smart Line Modules (example: 36 kW)

4.7.3.2 Line/load connection

Table 4-16 Connection methods for line reactor

Terminals	Designations
Power supply	1U1, 1V1, 1W1, PE
Load connection	1U2, 1V2, 1W2
Line reactors for Smart Line Modules	
5 kW	Screw terminal 4 mm ² 3-pin*
10 kW	Screw terminal 10 mm ² 3-pin*
16 kW	Screw terminal 10 mm ² 3-pin* with PE connection for ring cable lug M5 to DIN 46234
36 kW	Screw terminal 16 mm ² 3-pin* with PE connection for ring cable lug M6 to DIN 46234

* See Screw Terminals

4.7.4 Dimension Drawings

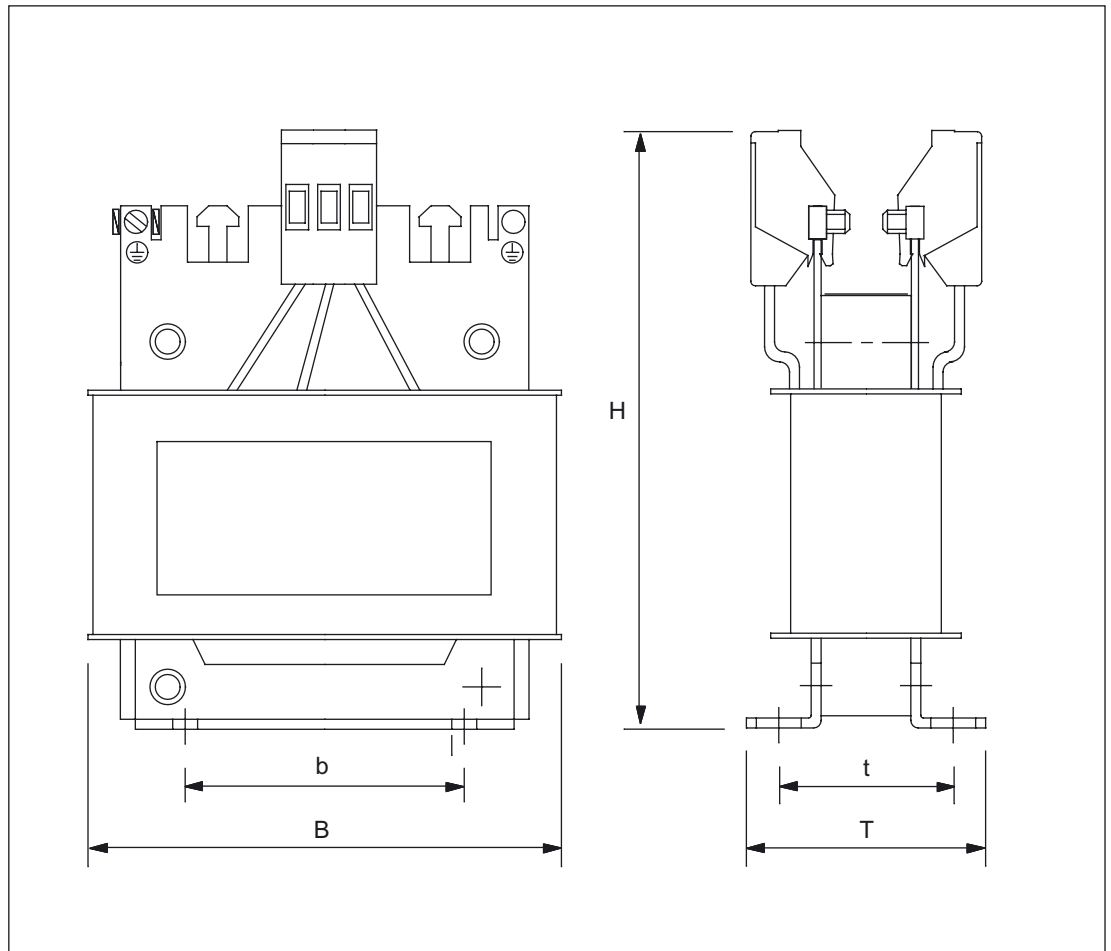

Figure 4-13 Dimension drawing: line reactor for Smart Line Modules (5 and 10 kW)

Table 4-17 Dimensions of the line filter for Smart Line Modules

	Order number 6SL3000-	W [mm] (inches)	w [mm] ¹⁾ (inches)	H [mm] (inches)	T [mm] (inches)	t [mm] ¹⁾ (inches)
5 kW	0CE-15-0AA0	150 (5.91)	113 (4.53)	175 (6.89)	66.5 (2.62)	49.5 (1.95)
10 kW	0CE-21-0AA0	177 (6.97)	136 (5.35)	196 (7.72)	86 (3.39)	67 (2.64)

1) Dimensions w and t correspond to the drill hole spacing

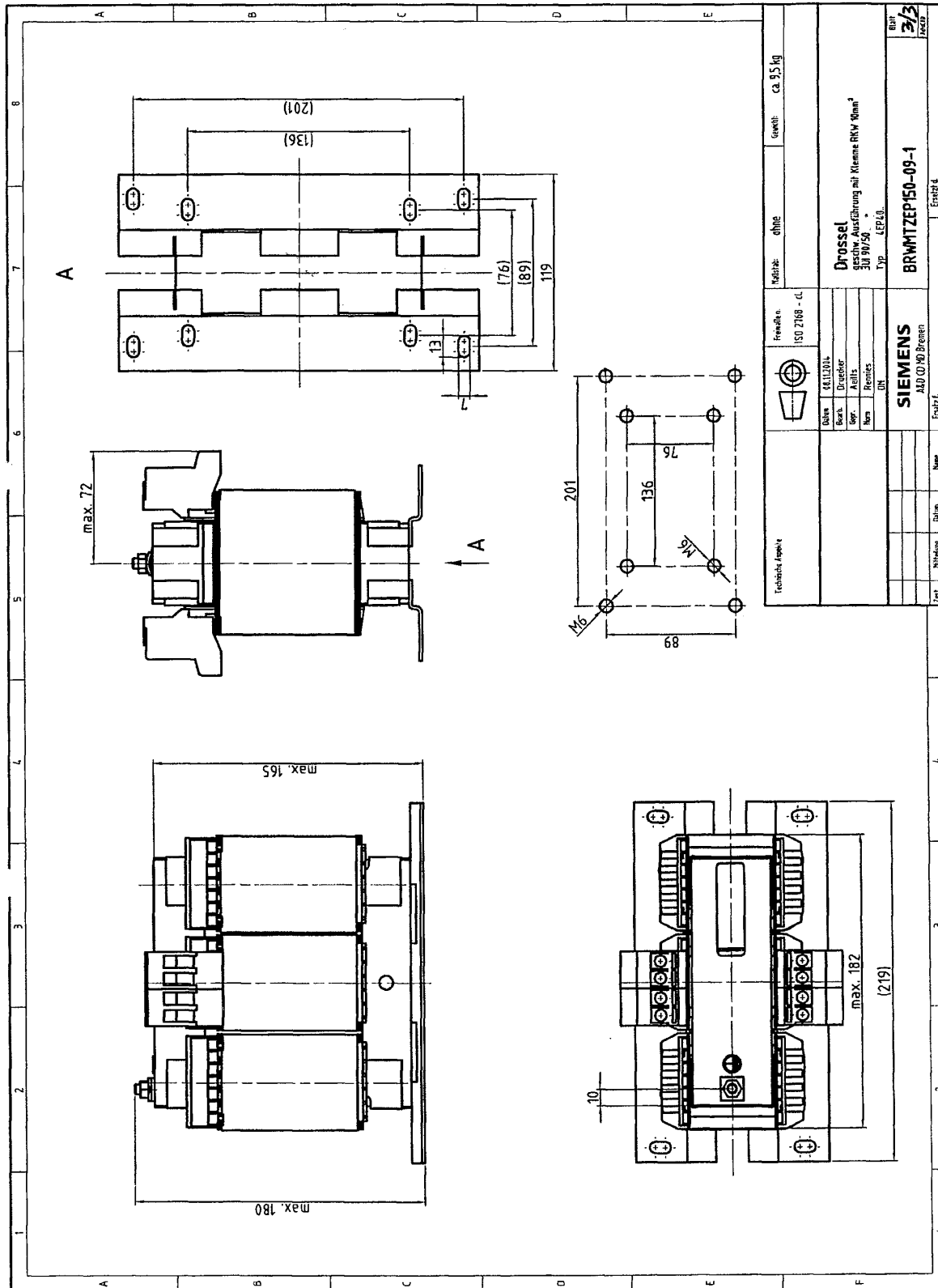

Figure 4-14 Dimension drawing of line reactor for the Smart Line Module 16 kW

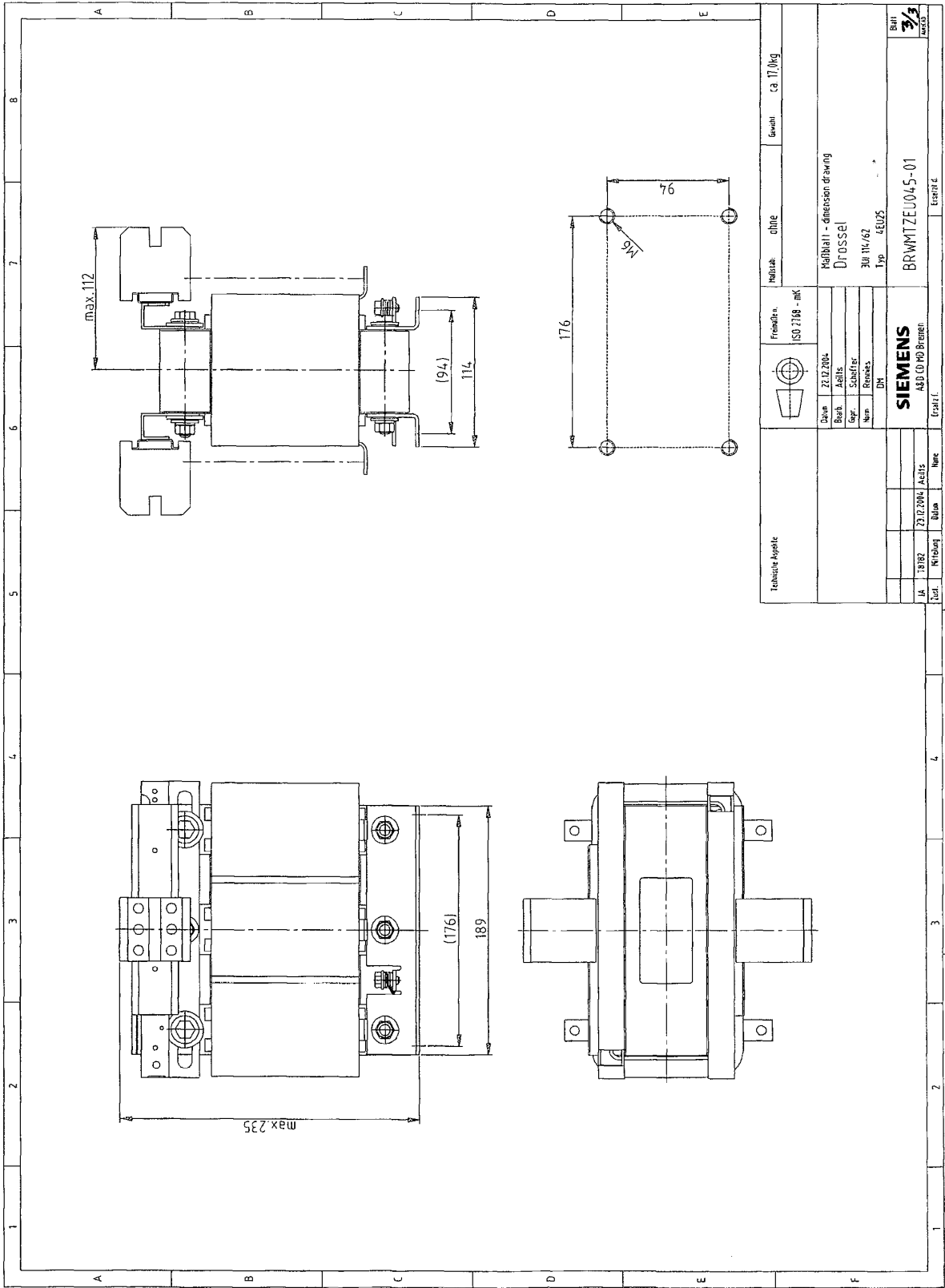

Figure 4-15 Dimension drawing of the line reactor for the Smart Line Module 36 kW

4.7 Line reactors for Smart Line Modules

Table 4-18 Line reactor for the Smart Line Modules 16 kW and 36 kW

	Order number 6SL3000-
16 kW	OCE-21-6AA0
36 kW	OCE-23-6AA0

4.7.5 Technical specifications

Table 4-19 Technical specifications of line reactors for the Smart Line Module

	6SL3000 unit	OCE15-0AA0	OCE21-0AA0	OCE22-0AA0	OCE24-0AA0
Output	kW	5	10	16	36
Rated current	A _{rms}	14	28	35	69
Power loss ¹	W	62	116	110	170
Weight	kg	3.7	7.5	9.5	17

¹ For an overview, see the power loss tables in Cabinet Design.

4.8 Line connection variants

4.8.1 Methods of line connection

A distinction is made between:

- Direct operation of the line connection components on the supply
- Operation of the Line Connection Components via an Autotransformer
- Operation of the Line Connection Components via an Isolating Transformer

4.8 Line connection variants

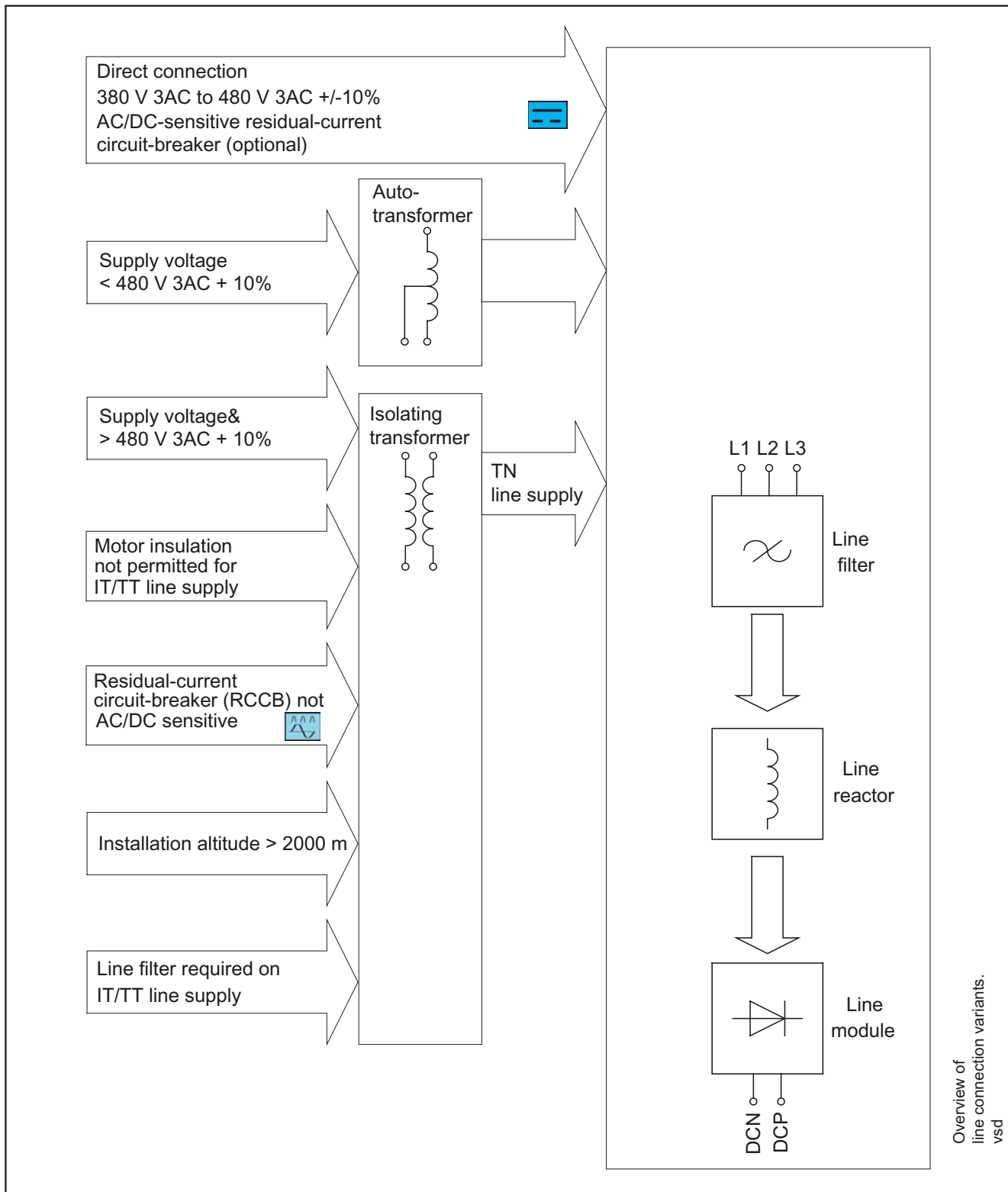

Figure 4-16 Overview of line connection variants

4.8.2 Operation of the line connection components on the supply network

The SINAMICS S booksize drive system is rated for direct operation on TN, TT, and IT supply systems with a nominal voltage of 3AC 380 V to 3AC 480 V. Operation with a line filter is only permitted for a TN supply system.

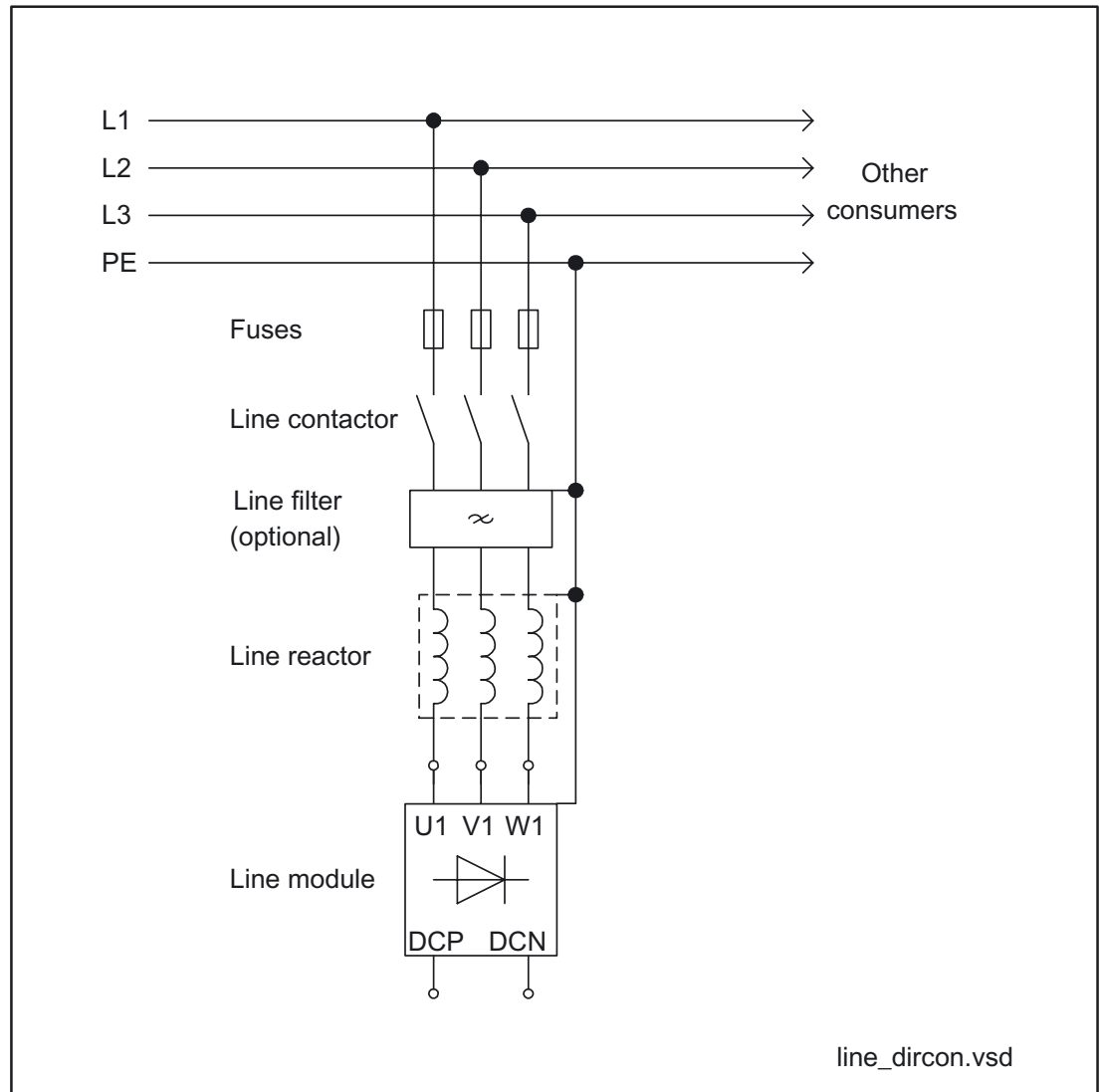

Figure 4-17 Direct operation on the supply network

4.8.3 Operation of the line connection components via an autotransformer

An autotransformer can be used for voltage adaptation in the range up to 3AC 480 V +10%.



Caution

To ensure safe electrical separation, an isolating transformer must be installed with voltages greater than 3AC 480 V +10%.

Applications:

- The motor insulation must be protected from excessive voltages.
- The active line module must provide a stabilized DC link voltage. It can be in the range 380 V to 415 V.

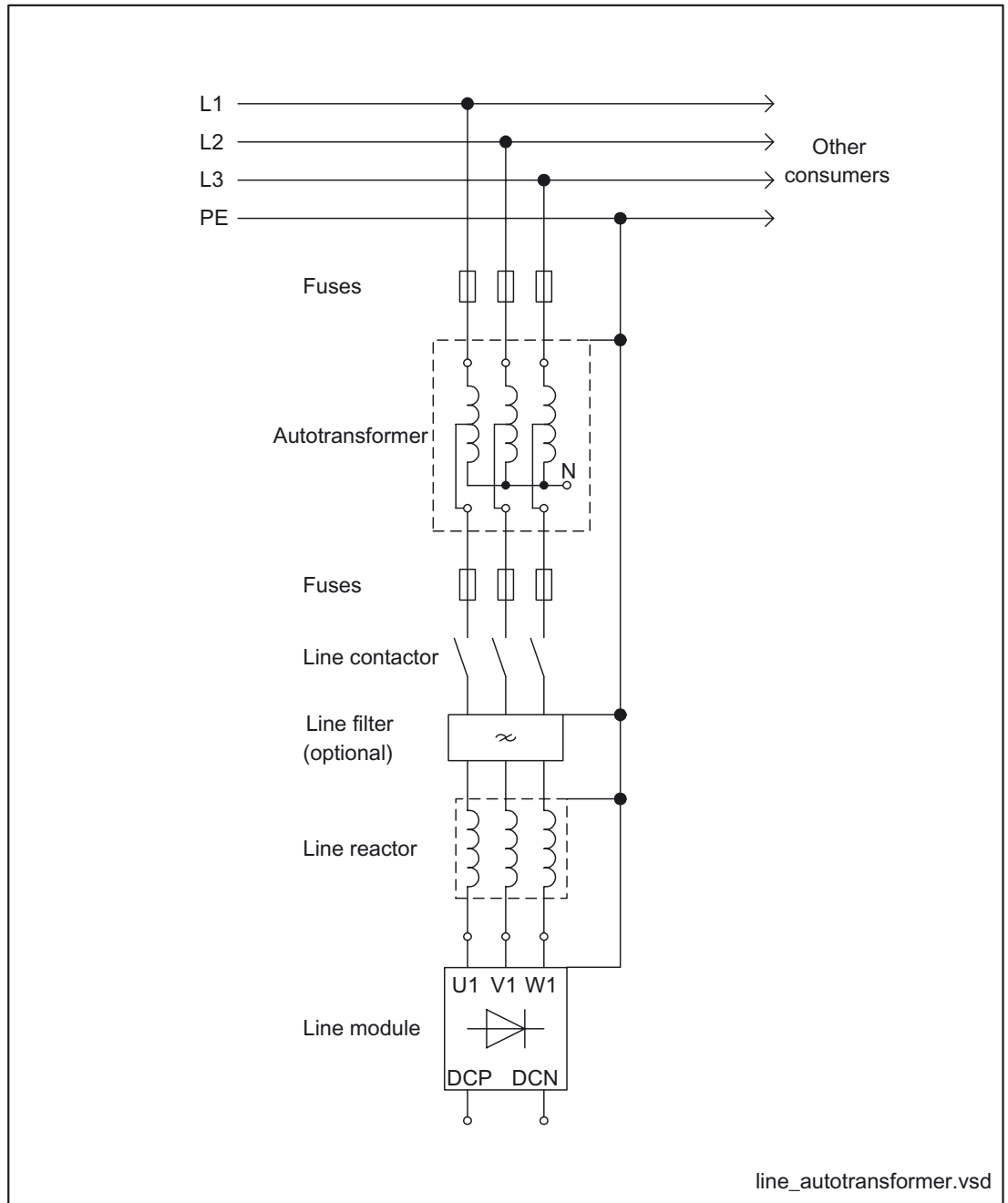

Figure 4-18 Autotransformer

4.8.4 Operation of the line connection components via an isolating transformer

The isolating transformer converts the network configuration of the system (e.g. IT/TT system) to a TN system. Additional voltage adaptation to the permissible voltage tolerance range is possible.

An isolating transformer must be used in the following cases:

- The motors are not approved for use in IT/TT systems.
- A residual-current circuit-breaker is required.
- The installation altitude is higher than 2000 m.
- A line filter is envisaged in an IT/TT system.

Caution

If the supply voltage is greater than 480 V +10%, an autotransformer must not be used. An isolating transformer must be used to ensure safe electrical separation.

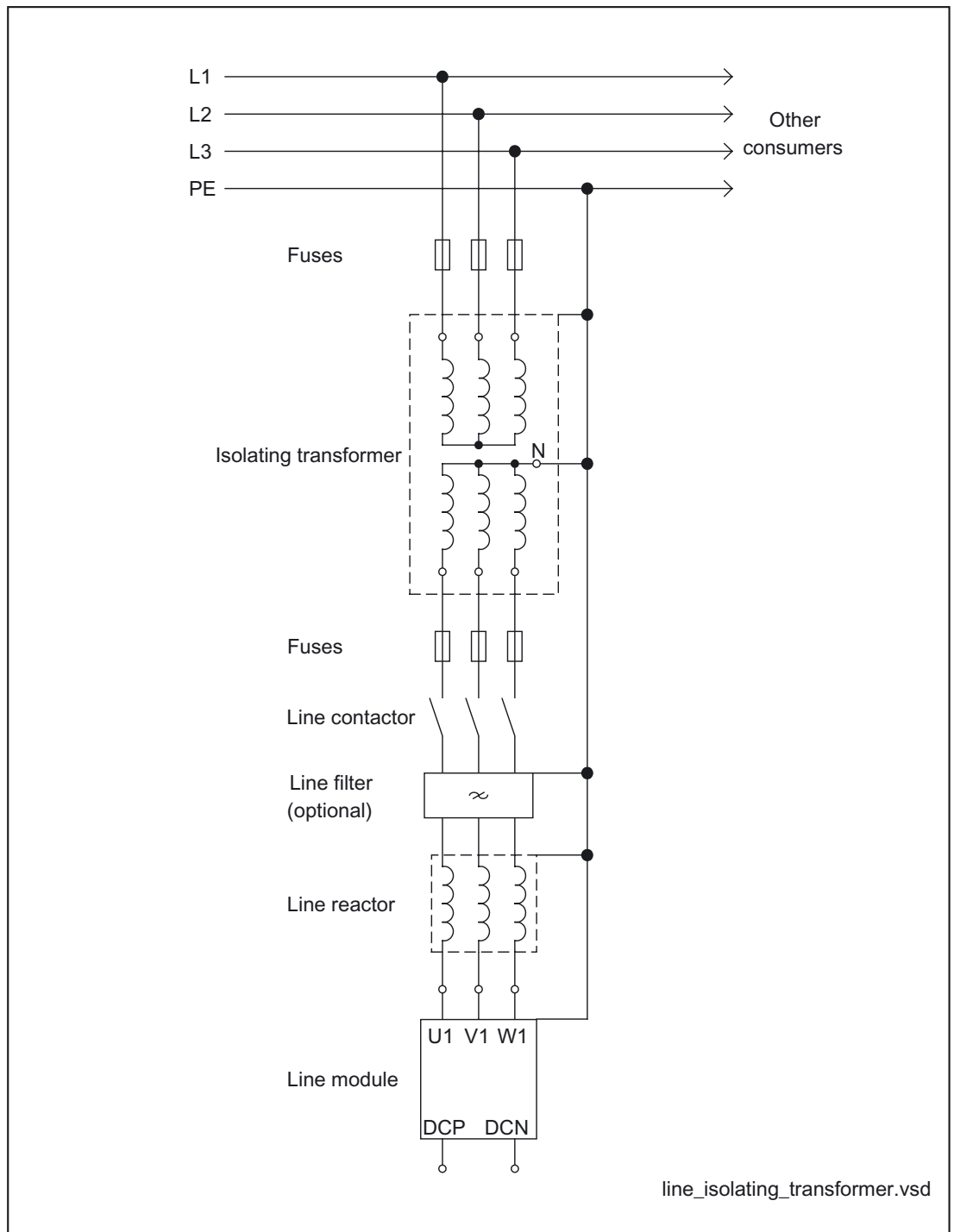

Figure 4-19 Isolating transformer

4.8.5 Line connection via a ground-fault circuit interrupter

In addition to protection measures against hazardous shock current (e.g. overcurrent trip), selectively tripping AC/DC-sensitive residual-current circuit-breakers can be used.

Note

A direct connection to a power system with selectively tripping AC/DC-sensitive residual-current circuit-breakers is only possible with the 5 kW, 10 kW, 16 kW and 36 kW Line Modules because suitable residual-current devices with higher ratings are not available as qualified products.

Selectively tripping AC/DC-sensitive residual-current circuit-breakers can be used without restriction in the event of a fault as a protective measure against hazardous shock currents.

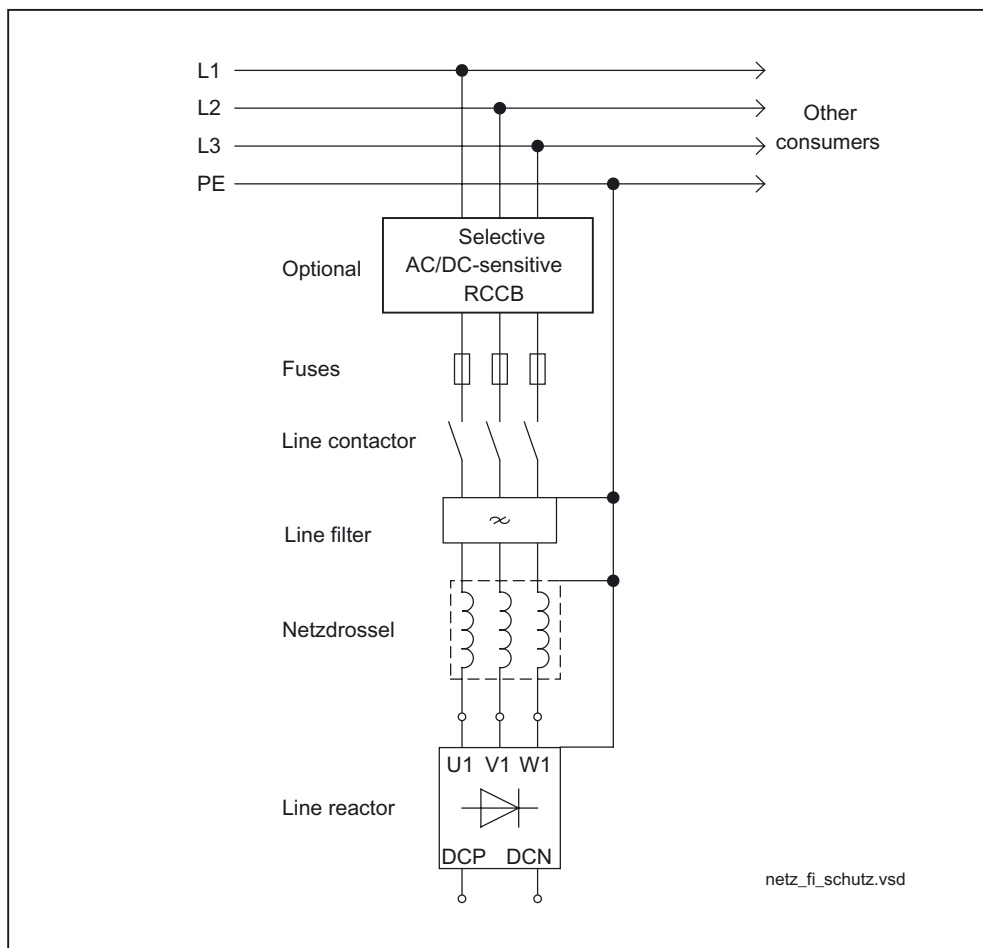

Figure 4-20 Residual-current circuit-breaker (RCCB)

Please note the following:

- Only the use of a delayed-tripping (selective) AC/DC-sensitive RCCB is permitted.
- The maximum permissible ground resistance of the "selective protection device" must be observed (max. 83 Ω for residual-current circuit-breakers with a rated differential current of 0.3 A).
- Parts of the electrical equipment and machine that can be touched are integrated in a protective grounding system.
- The total length of the shielded power cables used in the drive line-up (motor cable incl. line supply cables from line filters to line feed terminals) must be less than 350 m.
- Only recommended line filters must be used during operation.
- Only one residual-current circuit-breaker may be connected in series (cascading is not possible).
- Switching elements (main circuit-breakers, contactors) for connecting and disconnecting the drive line-up must feature a max. 35ms delay time between closing and opening individual main contacts.

Recommendation

SIEMENS selectively switching AC/DC-sensitive residual-current circuit-breakers to EN 50178, type 5SZ (e.g. 5SZ6 468-0KG00 or 5SZ6468-0KG30 with auxiliary disconnecter (1NC/1NO) for rated current 63 A, rated fault current 0.3 A) (see also catalog CA01).

Notice

AC or pulse-sensitive RCCBs are not suitable.

Active line modules with cold plate

5.1 Description

The Motor Modules are connected to the power supply network via the Active Line Modules which provide the Motor Modules with a constant DC link voltage.

This ensures that they are not influenced by network fluctuations.

When the motors are in feedback mode, Active Line Modules supply power back to the network. The regenerative feedback capability of the modules can be deactivated by parameterization.

The DC link starts precharging as soon as the supply voltage is applied and is independent of its phase sequence direction. Load can be applied to the DC link after the modules have been enabled. An optional main contactor is required for disconnecting the voltage.

The Active Line Modules are suitable for direct operation on TN, IT, and TT systems.

5.2 Safety Information



Warning

After disconnecting all the supply voltages, a hazardous voltage will be present in all components for another 5 minutes. The protective cover must not be opened until this time has elapsed.

When opening the protective cover for the DC link, you must activate the release. A suitable tool (e.g. screwdriver) must be used for this purpose.

The components must only be operated when the protective cover of the DC link is closed. Damaged components must not be used, otherwise this could result in secondary damage or accidents.



Warning

A sufficiently high short-circuit power is required for tripping the fuses within the predefined time in the event of a ground fault. Insufficient short-circuit power increases the time to trip beyond permissible levels (e.g. fire possible).



Caution

The Active Line Modules conduct a high leakage current via the PE conductor. Because of the high leakage current of the Active Line Modules, a permanent PE connection of the Active Line Module or switching cabinet is required. Because of the high leakage current of the Motor Modules, a permanent PE connection of the Motor Module or switching cabinet is required.

Measures according to EN 61800-5-1 must be taken (e.g. PE conductor ($\geq 10\text{mm}^2$ Cu) or fit an additional connection terminal for a PE conductor with the same cross-section as the original PE conductor).

Caution

The DC link discharge time hazard warning must be affixed to the modules in the local language.

A set of labels in 12 languages is available using order number: 6SL3166-3AB00-0AAx.

Notice

The 80 mm clearances above and below the components must be observed.

Caution

The tightening torque of the DC link busbar screws (1.8 Nm, tolerance: +30%) must be checked before startup. After transportation, the screws must be tightened.

In a supply system without regenerative feedback capability (e.g. diesel generator), the regenerative feedback capability of the Active Line Module must be deactivated via a parameter (see Description of Functions). The braking energy must then be dissipated via an additional Braking Module with a braking resistor in the drive line-up.

Caution

The total length of the power cables (motor supply cables and DC link cables) must not exceed 350 m in active mode.

Caution

Only cables from Siemens must be used for DRIVE-CLiQ connections.

Caution

The left and right ends of the DC link busbar of a drive line-up must be fitted with peripheral covers (order no.: 6SL3162-5AA00-0AA0).

5.3 Interface description

5.3.1 Overview

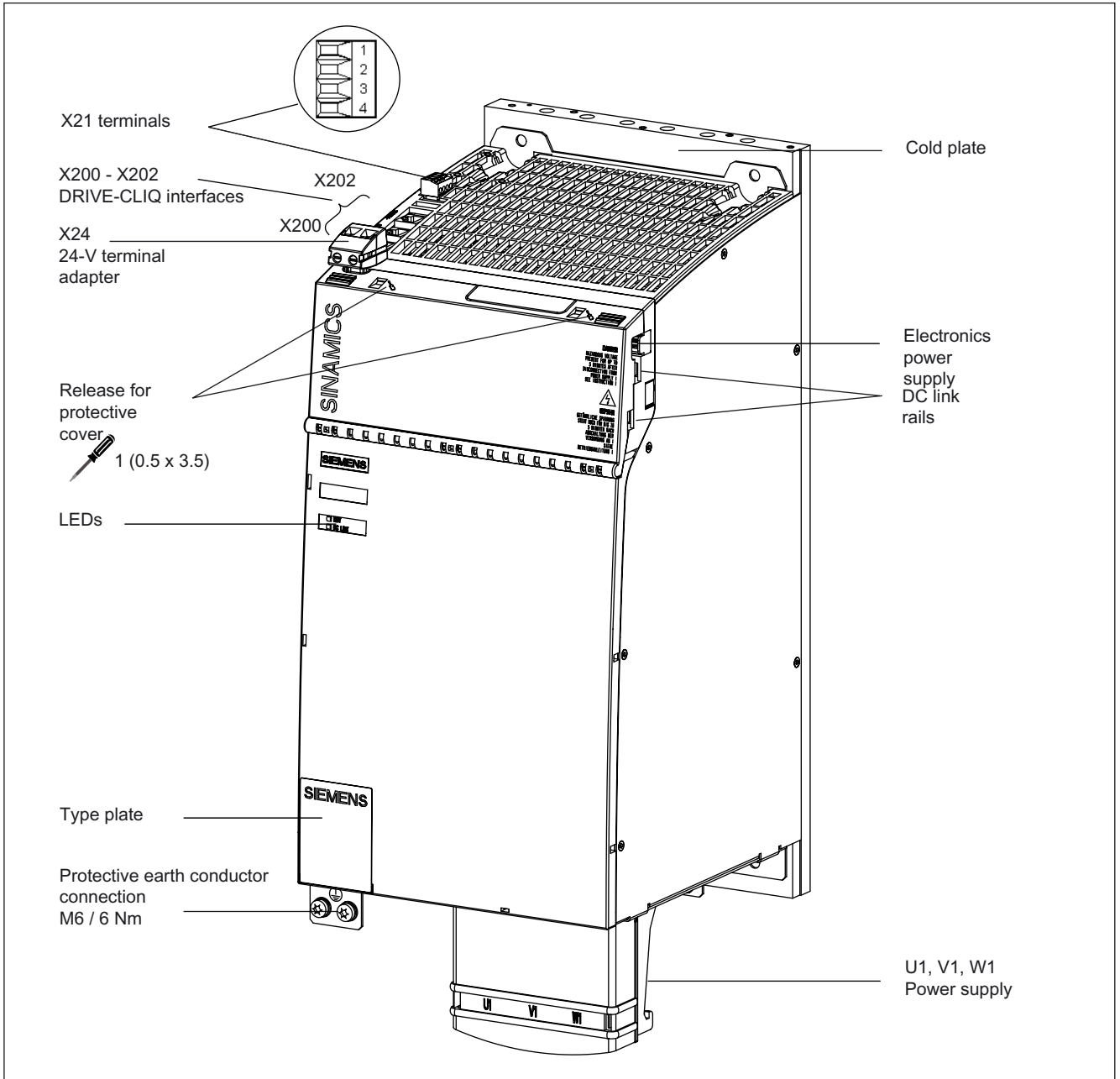

Figure 5-1 Active line module With cold plate (example: 55 kW)

5.3.2 Connection example

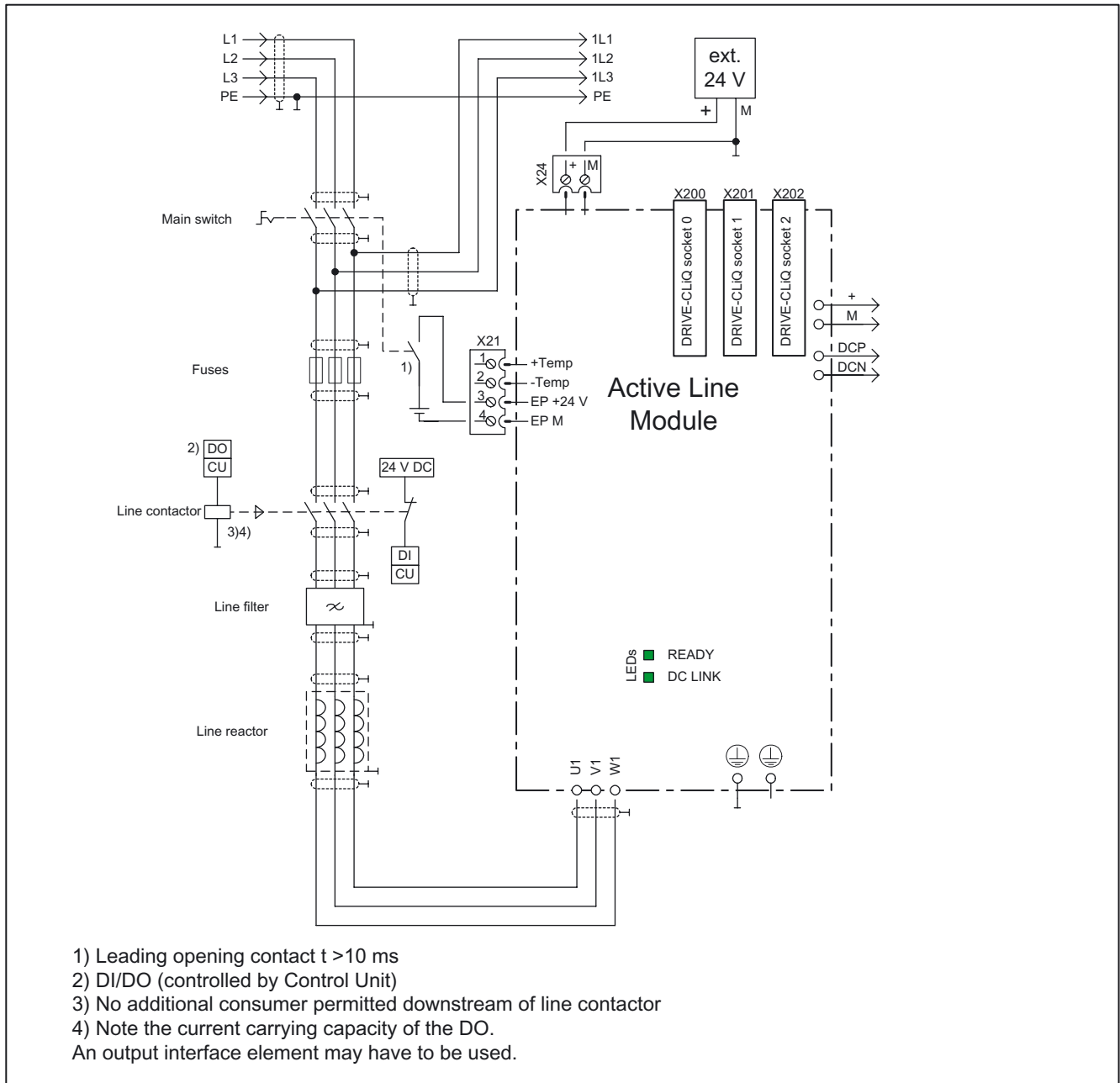
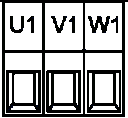



Figure 5-2 Connection example: active line module with cold plate

5.3.3 X1 line connection

Table 5-1 Terminal block X1 Active Line Module 16 kW

	Terminal	Technical specifications
	U1	Max. connection voltage: 3AC 480 V +10 at 47 Hz to 63 Hz Max. connectable cross-section: 10 mm ² Type: Screw terminal 6 (see Connection Methods)
	V1	
	W1	
	PE connection	Threaded hole M5/3 Nm ¹

¹ for ring cable lugs to DIN 46234

Table 5-2 Terminal block for the Active Line Module (36 kW to 120 kW)

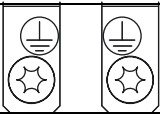
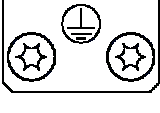
	Terminals	Technical specifications
	U1	Max. connection voltage: 3AC 480 V +10% at 47 Hz to 63 Hz 36kW: Threaded bolt M6/6 Nm ¹ 55 kW: Threaded bolt M8/13 Nm ¹ 80 kW to 120 kW: Threaded bolt M8/13 Nm ¹
	V1	
	W1	
	PE connection	36kW: Threaded hole M6/6 Nm ¹
		55 kW: Threaded hole M6/6 Nm ¹ 80 kW to 120 kW: Threaded hole M8/13 Nm ¹

¹ for ring cable lugs to DIN 46234

5.3 Interface description

5.3.4 X200-X202 DRIVE-CLiQ interfaces

Table 5-3 DRIVE-CLiQ interface X200-X202

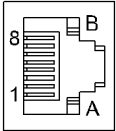
	PIN	Signal name	Technical specifications
	1	TXP	Transmit data +
	2	TXN	Transmit data -
	3	RXP	Receive data +
	4	Reserved, do not use	
	5	Reserved, do not use	
	6	RXN	Receive data -
	7	Reserved, do not use	
	8	Reserved, do not use	
	A	+ (24 V)	24 V power supply
	B	GND (0 V)	Electronic ground
Blanking plate for DRIVE-CLiQ interface: Molex, order number: 85999-3255			

5.3.5 EP terminals X21

Table 5-4 Terminal block X21

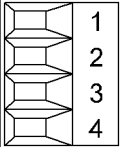
	Terminal	Designation	Technical specifications
	1	Reserved, do not use	
	2	Reserved, do not use	
	2	EP +24 V (enable pulses)	Voltage 24 V DC Current consumption: 10 mA
	4	EP M (enable pulses)	Isolated input Signal propagation times: L → H: 100 μs H → L: 1000 μs
Max. connectable cross-section: 1.5 mm ² Type: Screw terminal 1 (see Appendix A)			

Note

For operation, 24 V DC must be connected to terminal 3 and ground to terminal 4. When removed, pulse inhibit is activated (if this has been parameterized).

If the Line Module is not disconnected from the network (e.g. with a main contactor), the DC link remains charged.

Notice

Before the drive line-up is switched off by means of the line disconnecting device, the voltage at terminals 3 (EP +24 V) and 4 (EP M) must be interrupted. This can be carried out using a leading breaking auxiliary contact (≥ 10 ms), for example.

5.3.6 X24 24 V terminal adapter

Table 5-5 Terminal block X24

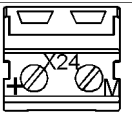
	Terminal	Designation	Technical specifications
	+	24 V power supply	24 V DC supply voltage
	M (GND)	Ground	Electronic ground
The 24 V terminal adapter is supplied as standard Max. connectable cross-section: 6 mm ² Type: Screw terminal 5 (see Appendix A)			

5.3.7 Meaning of the LEDs on the active line module

Table 5-6 Meaning of the LEDs on the Line Module

LED	Color	State	Description
READY	-	OFF	Electronics power supply outside permissible tolerance range.
	Green	Continuous	The component is ready for operation and cyclic DRIVE-CLiQ communication is taking place.
	Orange	Continuous	DRIVE-CLiQ communication is being established.
	Red	Continuous	At least one fault is present in this component.
	Green Red	Flashing 2 Hz	Firmware is being downloaded.
	Green/Orange or Red/Orange	Flashing 2 Hz	Component recognition via LED is activated (p0124). Note: Both options depend on the LED status when module recognition is activated via p0124 = 1.
DC LINK	-	OFF	Electronics power supply outside permissible tolerance range.
	Orange	Continuous	DC link voltage within permissible tolerance range (only when ready for operation)
	Red	Continuous	DC link voltage outside the permissible tolerance range (only when Active Line Module is ready for operation).

Cause and rectification of faults

The following reference contains information about the cause and rectification of faults:

Reference: /IH1/ SINAMICS S120 Commissioning Manual

5.4 Dimension Drawing

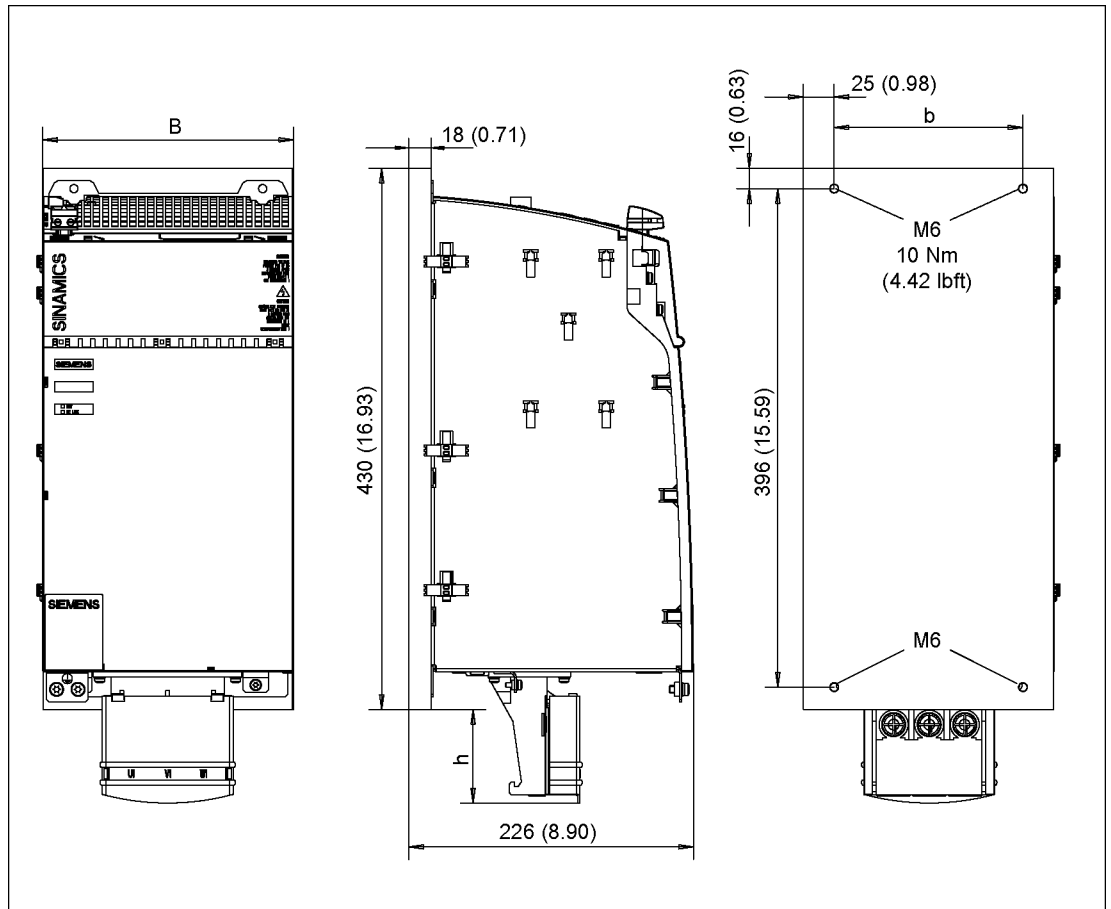

Figure 5-3 Dimension drawing of Active Line Module with cold plate

Table 5-7 Dimensions of Active Line Modules with cold plate

Line Module type	Order number	W [mm] (inches)	w [mm] (inches)	h [mm] (inches)
36 kW	6SL3136-7TE23-6AAx	150 (5.91)	100 (3.94)	78 (3.07)
55 kW	6SL3136-7TE25-5AAx	200 (7.87)	150 (5.91)	74 (2.91)
80 kW	6SL3136-7TE28-0AAx	300 (11.81)	250 (9.84)	74 (2.91)
120 kW	6SL3136-7TE31-2AAx	300 (11.81)	250 (9.84)	74 (2.91)

5.5 Installation

Installing the cold-plate modules on customer-specific heat sinks

Note the following before installation:

- Before installation, check the surface of the heat sink to ensure that it is not damaged.
- To facilitate installation, M6 screw bolts and hexagon nuts/threaded pins (ISO 7436-M6x40-14 H, strength class 8.8) are recommended.
- To improve heat transfer, a heat-conducting medium must be used. Special spherical-indented heat-conducting film must be used for this purpose. Each cold plate power section is supplied with heat-conducting film cut to the right size. Note the installation position of the heat-conducting film (see diagram below).

Note

When a module is replaced, the heat-conducting film must also be replaced. Only heat-conducting film approved or supplied by Siemens can be used.

Installation

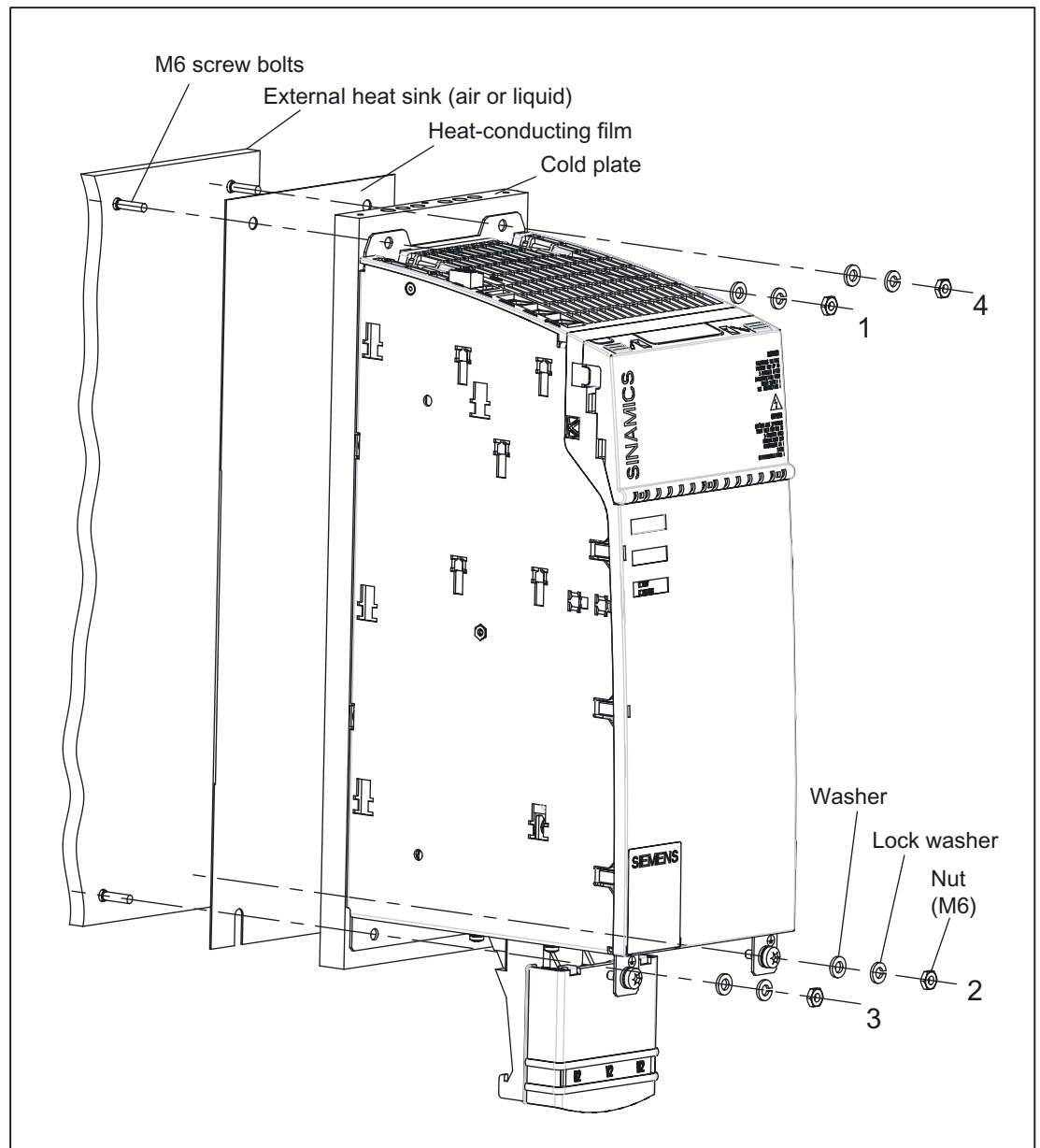

Figure 5-4 Installing a cold-plate power section with an external heat sink and heat-conducting film

To begin, tighten the screws by hand (approx. 0.5 Nm) in the sequence shown (steps 1 to 4) and then secure them (10 Nm).

Properties of the heat sink

AlMgSi 0.5 is recommended as the heat sink material.
The roughness of the external heat sink surface should be at least Rz 16 and the contact surface between the heat sink and cold plate should have an evenness of 0.2 mm (applicable to a height of 450 mm and width of 300 mm).

Note

The machine manufacturer can choose the right heat sink version for his special plant requirements. The specified rated data for the Power Modules can only be achieved if the power losses can be dissipated from the external heat sink under the specified general conditions.

Notice

During installation, you must make sure that the threaded bolts do not damage the cold plate.

Remove the holder for securing the Control Unit.

If an additional component is to be flush-mounted to the left of the component, the holders for securing the Control Unit must be removed.

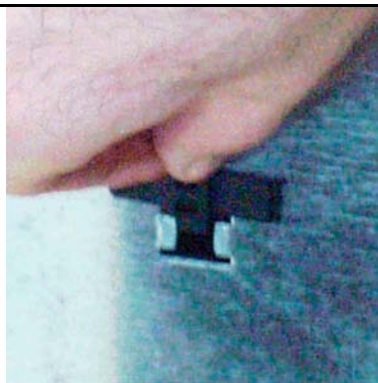
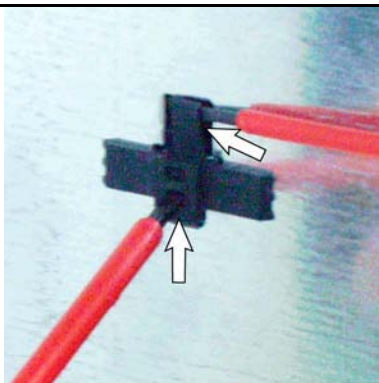

Use suitable tools to lift the latching device and push up the holder.

Remove the holder.

The holder removed

5.6 Technical Specifications

Table 5-8 Technical specifications for Active Line Modules with cold-plate cooling

	6SL3136-7TE	21-6AAx	23-6AAx	25-5AAx	28-0AAx ²⁾	31-2AAx ²⁾
Rated power	kW	16	36	55	80	120
Connection voltages: Line voltage Line frequency Electronics power supply	V _{ACrms} Hz V _{DC}	3 AC 380 – 10% to 3 AC 480 + 10% (-15% < 1 min) 47 to 63 24 (20.4 – 28.8)				
DC link voltage Overvoltage tripping Undervoltage tripping	V _{DC} V _{DC} V _{DC}	510 – 750 820 ± 2% 360 ± 2%				
DC link busbar current carrying capacity	A _{ACrms}	100	100	200	200	200
24 V busbar current carrying capacity	A _{ACrms}	20	20	20	20	20
Electronics current consumption	A _{DC}	See Cabinet Design and EMC.				
Power: Rated power (S1) Power rating (S6-40%) Peak power rating	kW (P _n) kW (P _{s6}) kW (P _{max})	16 21 35	36 47 70	55 71 91	80 106 131	120 158 175
Regenerative feedback: Continuous feedback power rating Peak feedback power rating	kW kW	16 35	36 70	55 91	80 131	120 175
Supply currents: at 380 V _{AC} at 480 V _{AC} / 528 V _{AC} at 480 V; S6-40% Peak current (at 400 V _{AC} / 480 V _{AC})	A _{AC} A _{AC} A _{AC} A _{AC}	26 21 / 19 27 54 / 45	58 46 / 42 60 107 / 89	88 70 / 64 92 139 / 116	128 102 / 93 134 200 / 222	192 152 / 139 201 267 / 222
Output currents at 600 V _{DC} : Rated current at S6-40% Peak current	A _{DC} A _{DC} A _{DC}	27 35 59	60 79 117	92 121 152	134 176 195	200 244 292
Max. permissible heat sink temperature	°C	70	70	78	70	75
Max. ambient temperature without derating	°C	40	40	40	40	40
Max. ambient temperature with derating	°C	55	55	55	55	55
DC link capacitance	µF	710	1410	1880	2820	3760
Charging limit	µF	20 000	20 000	20 000	20 000	20 000

5.6 Technical Specifications

	6SL3136-7TE	21-6AAx	23-6AAx	25-5AAx	28-0AAx ²⁾	31-2AAx ²⁾
Power factor	$\cos\phi$	1	1	1	1	1
Efficiency	η	0.98	0.98	0.98	0.98	0.98
Weight	kg	6.1	10.2	13.8	20.3	20.4
Power loss		See Cabinet Design and EMC				

1) The specified values apply for 380 V

2) The specified rated power values/currents can only be achieved if direct liquid cooling is used. Derating will occur if installed on an external heat sink. At a temperature of 40 °C at the interface to the power section, 80% derating occurs for 6SL3136-7TE 28-0AAx and 70% for 6SL3136-7TE 31-2AAx

Rated duty cycles of Active Line Modules

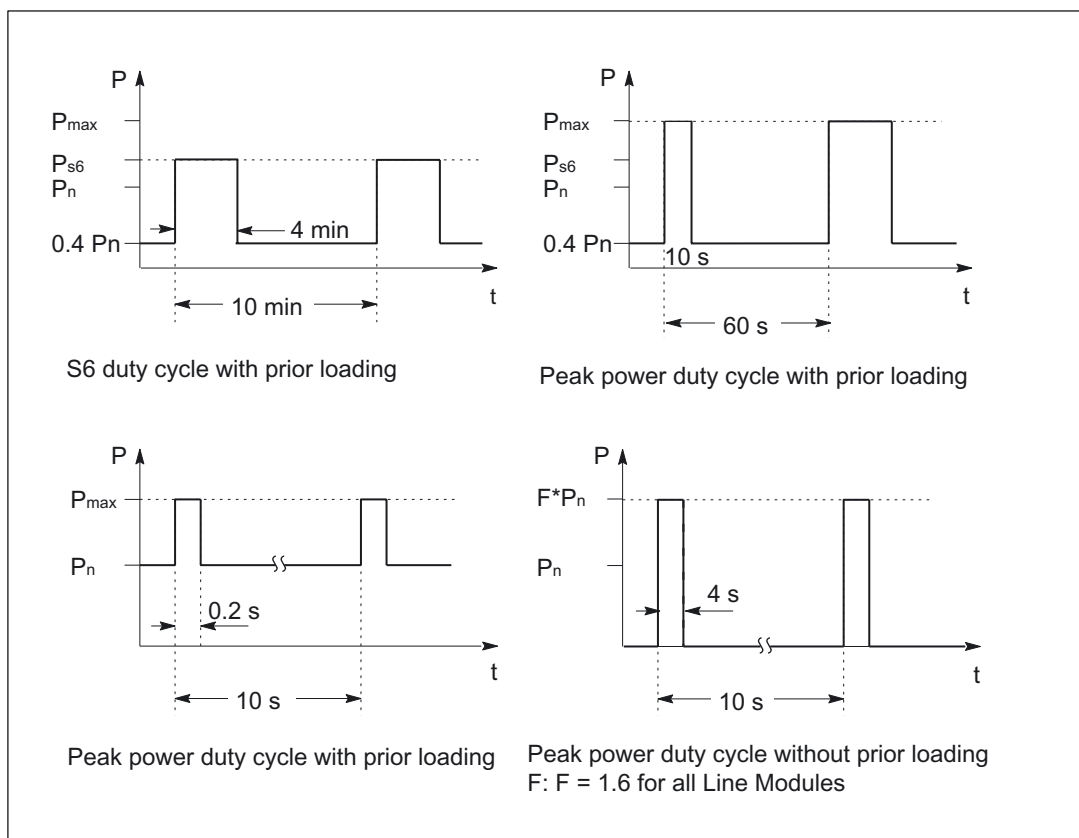

Figure 5-5 Rated duty cycles of Active Line Modules

Derating as a function of the ambient temperature

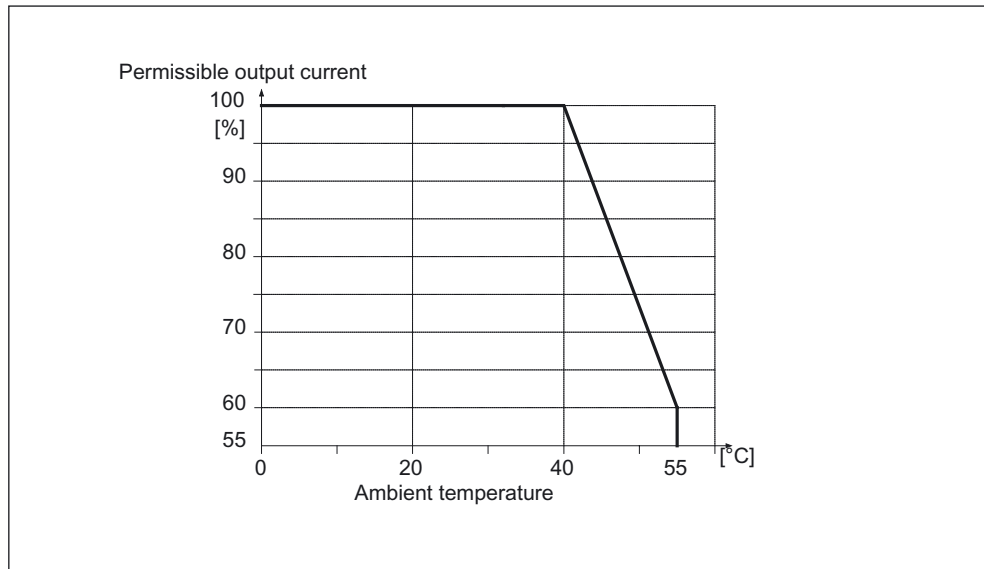

Figure 5-6 Derating as a function of the ambient temperature

Derating as a function of the installation altitude

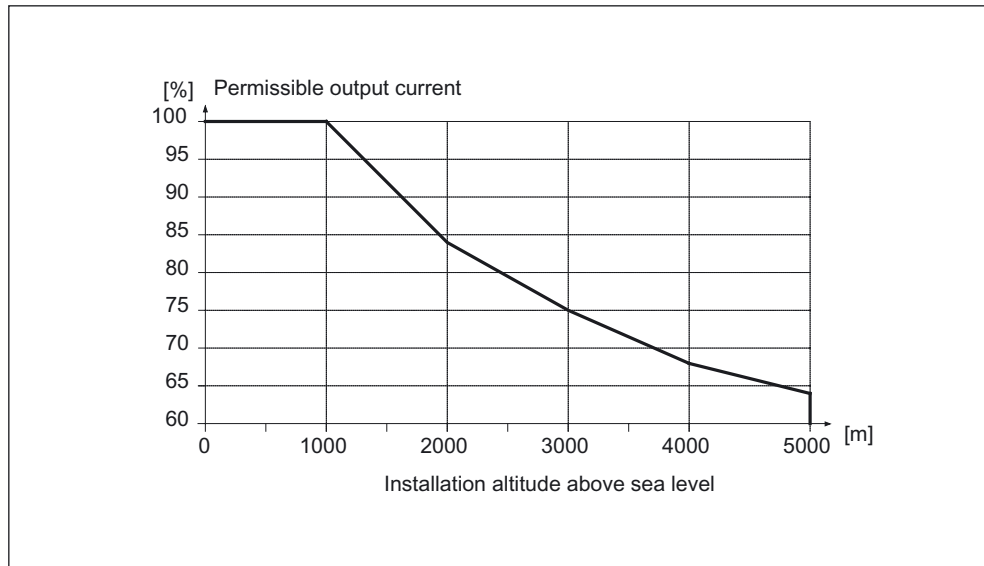

Figure 5-7 Derating as a function of the installation altitude

Smart Line Modules (5 kW and 10 kW) with cold plate

6

6.1 Description

The Smart Line Module (SLM) is an unregulated line infeed/feedback unit. The SLM supplies the Motor Module(s) with an unregulated DC voltage at the DC output. As regards the current and voltage waveform, the SLM in infeed mode exhibits the typical characteristic of a 6-pulse diode rectifier jumper.

In feedback mode, the current waveform is square waved. Feedback can be deactivated by means of a terminal because these Smart Lines Modules are not equipped with a DRIVE-CLiQ connection.

The DC link starts precharging as soon as the supply voltage is applied and is independent of its phase sequence direction. Load can be applied to the DC link after the modules have been enabled. An optional main contactor is required for disconnecting the voltage.

Smart Line Modules are suitable for direct operation in TN, IT, and TT systems.

6.2 Safety Information



Warning

After disconnecting all the supply voltages, a hazardous voltage will be present in all components for another 5 minutes. The protective cover must not be opened until this time has elapsed.

When opening the protective cover for the DC link, you must activate the release. A suitable tool (e.g. screwdriver) must be used for this purpose.

The components must only be operated when the protective cover of the DC link is closed. Damaged components must not be used, otherwise this could result in secondary damage or accidents.



Warning

A sufficiently high short-circuit power is required for tripping the fuses within the predefined time in the event of a ground fault. Insufficient short-circuit power increases the time to trip beyond permissible levels (e.g. fire possible).



Caution

The DC link discharge time hazard warning must be affixed to the modules in the local language.

A set of labels in 12 languages is available using order number: 6SL3166-3AB00-0AAx.

Notice

The 80 mm clearances above and below the components must be observed.

Caution

The tightening torque of the DC link busbar screws (1.8 Nm, tolerance: +30%) must be checked before startup when the system is disconnected from the power supply and the DC link is discharged. After transportation, the screws must be tightened.



Danger

In a supply system without regenerative feedback capability (e.g. diesel generator), the regenerative feedback capability of the Smart Line Module must be deactivated by means of a jumper between terminals X22.1 and X22.2. The braking energy must then be dissipated via an additional Braking Module with a braking resistor in the drive line-up.

Caution

The total length of the power cables (motor supply cables and DC link cables) must not exceed 350 m.

Notice

Operation without the line reactor is not permissible.

Caution

The ratio of line short-circuit power to rated power must be ≥ 70 .

Caution

The left and right ends of the DC link busbar of a drive line-up must be fitted with peripheral covers (order no.: 6SL3162-5AA00-0AA0).



Warning

If the Line Module is not disconnected from the network (e.g. via the main contactor or main circuit-breaker), the DC link remains charged.

6.3 Interface description

6.3.1 Overview

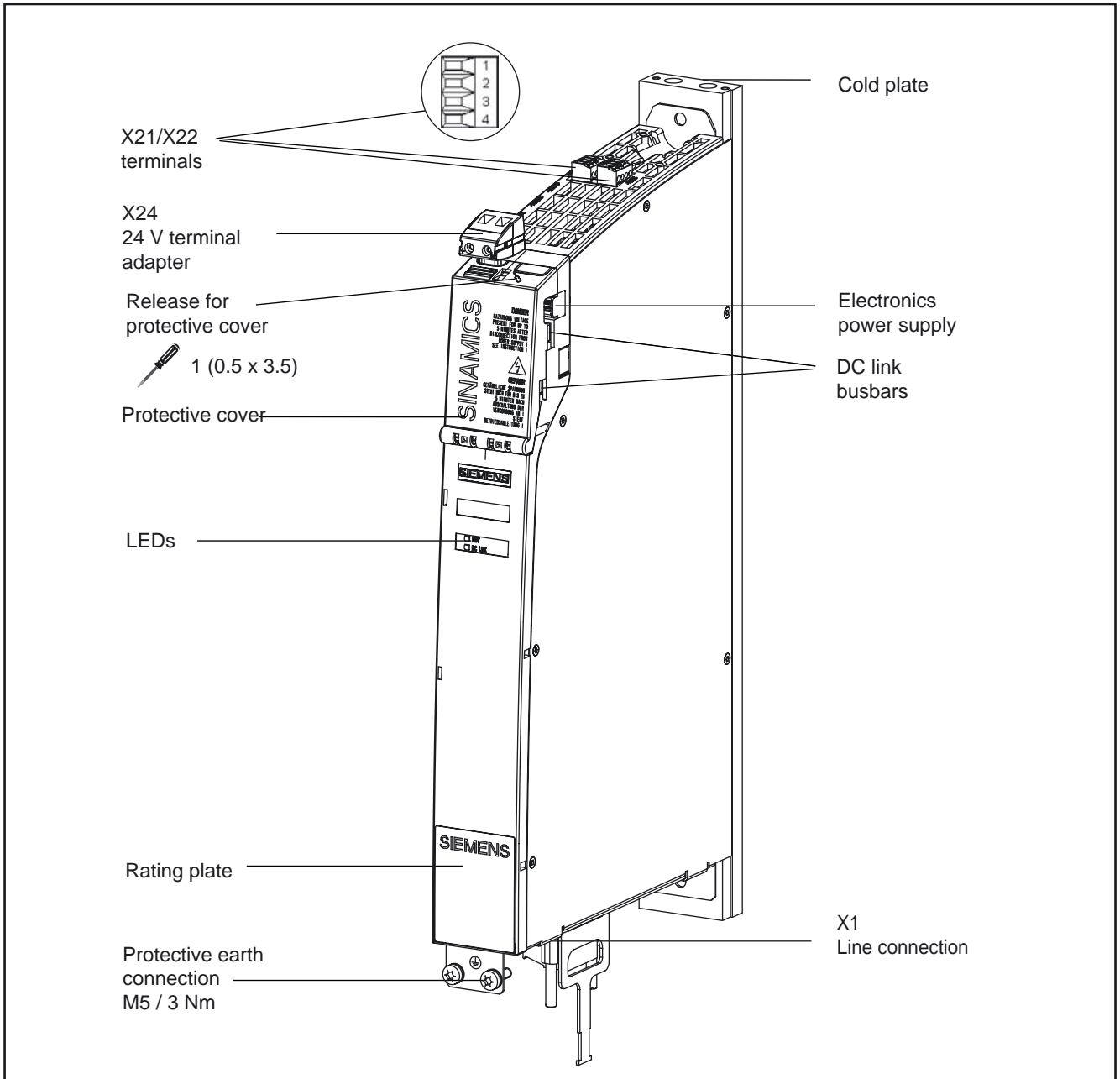

Figure 6-1 Smart line module with cold plate (10 kW)

6.3 Interface description

6.3.2 Connection example

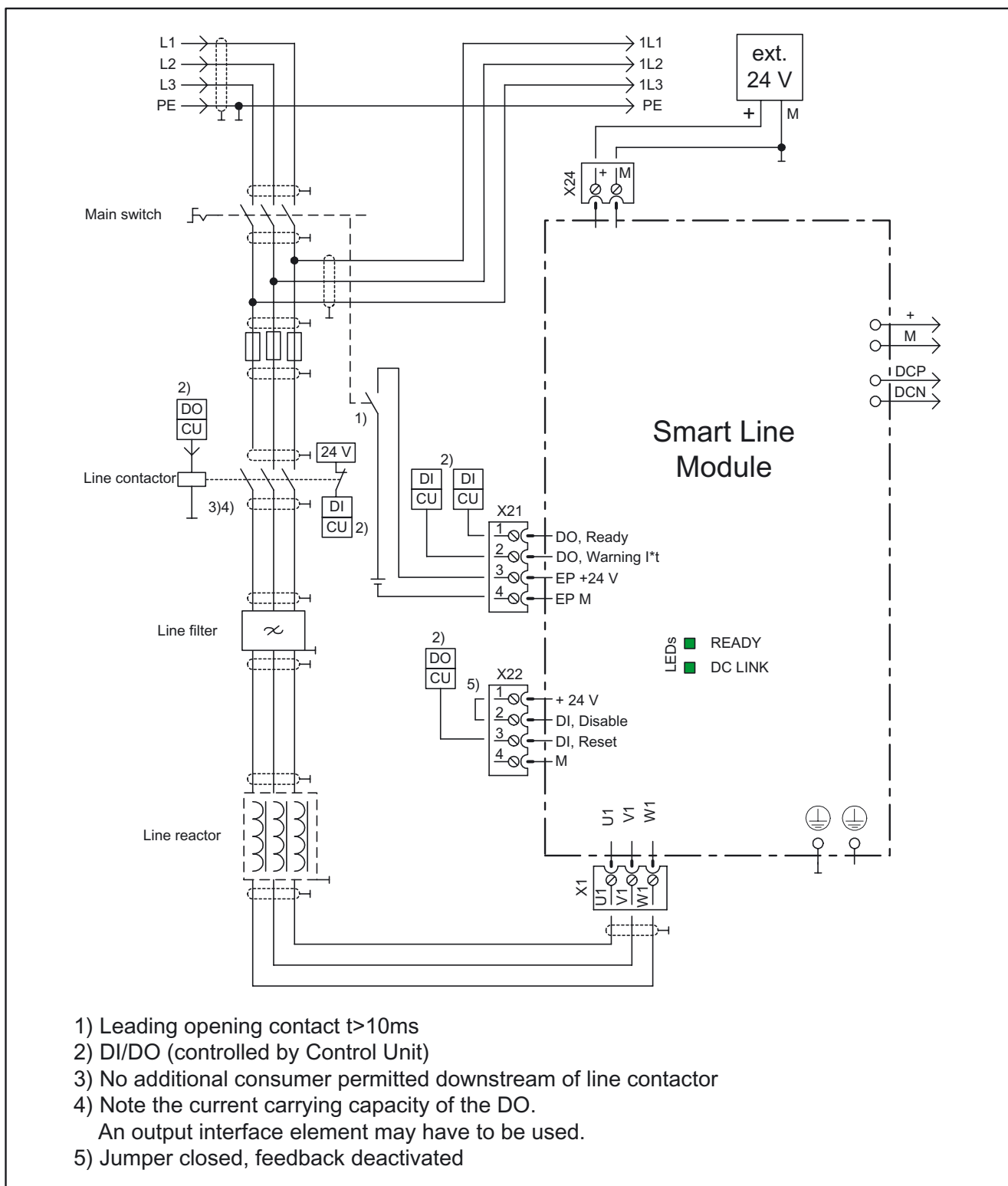
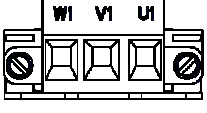
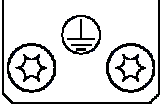

Figure 6-2 Connection example: smart line module with cold plate

6.3.3 X1 line connection

Table 6-1 Terminal block X1 of Smart Line Module (5 kW and 10 kW)

	Terminal	Technical specifications
	U1	Max. connection voltage: 3AC 480 V +10 at 47 Hz to 63 Hz Max. connectable cross-section: 6 mm ² Type: Screw terminal 5 (see Connection Methods)
	V1	
	W1	
	PE connection	Threaded hole M5/3 Nm ¹

¹ for ring cable lugs to DIN 46234

6.3 Interface description

6.3.4 X21 terminals: smart line module

Table 6-2 Terminal block X21

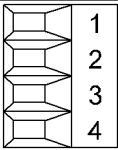
	Terminal	Name	Technical specifications
	1	DO: Ready	Checkback: Smart Line Module ready The signal switches to high level when the following conditions have been met: <ul style="list-style-type: none"> • Electronics power supply (X24) OK • DC link is pre-charged • Pulses enabled (X21.3/.4) • No overtemperature • No overcurrent switch-off
	2	DO: Pre Warning	Prewarning threshold overtemperature / I x t When 80% of the maximum temperature of the Smart Line Module is exceeded, a high signal is output.
	3	DI: Enable pulses	Voltage 24 V DC Current consumption: 10 mA
	4	DI: Enable pulses ground	Isolated input
Max. connectable cross-section: 1.5 mm ² Type: Screw terminal 1 (see Spring-Loaded Terminals/Screw Terminals)			

Note

For operation, 24 V DC must be connected to terminal 3 and ground to terminal 4. When removed, pulse inhibit is activated, feedback is deactivated and the bypass relay drops out. If the Line Module is not disconnected from the network when the EP terminal is deactivated (e.g. a main contactor is not installed), the DC link remains charged.

Notice

If a drive line-up is switched off by means of the line disconnecting device, the voltage at terminals 3 (EP +24 V) and 4 (EP M) must be interrupted beforehand. This can be carried out using a leading breaking auxiliary contact (≥ 10 ms), for example.

6.3.5 X22 terminals: smart line module

Table 6-3 Terminal block X22

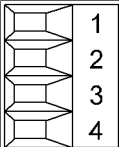
	Terminal	Name	Technical specifications
	1	24 V power supply	Electronics power supply for controlling digital inputs X22.2 and 3.
	2	DI: Disable Regeneration	Deactivate feedback No power is supplied back to the network from the DC link. The regenerative energy of the motors may have to be reduced using a combination of the Braking Module and braking resistor.
	3	DI: Reset	Reset faults (positive edge)
	4	Ground	Electronic ground
Max. connectable cross-section: 1.5 mm ² Type: Screw terminal 1 (see Connection Methods)			

6.3.6 X24 24 V terminal adapter

Table 6-4 Terminal block X24

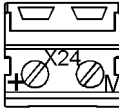
	Terminal	Designation	Technical specifications
	+	24 V power supply	24 V DC supply voltage
	M (GND)	Ground	Electronic ground
The 24 V terminal adapter is supplied as standard Max. connectable cross-section: 6 mm ²			

6.3.7 Meaning of the LEDs on the smart line module with cold plate

Table 6-5 Meaning of the LEDs on the smart line module with cold plate

LED	Color	State	Description
READY	Green	Continuous	Ready
	Yellow	Continuous	Precharging not yet complete
	Red	Continuous	Overtemperature/overcurrent switchoff, or electronics power supply outside the permissible tolerance range, or DC link outside the permissible tolerance range
DC LINK		OFF	Electronics power supply outside permissible tolerance range
	Yellow	Continuous	DC link voltage within permissible tolerance range
	Red	Continuous	DC link voltage outside permissible tolerance range

Cause and rectification of faults

The following reference contains information about the cause and rectification of faults:

Reference: /IH1/ SINAMICS S120 Commissioning Manual

6.4 Dimension Drawing

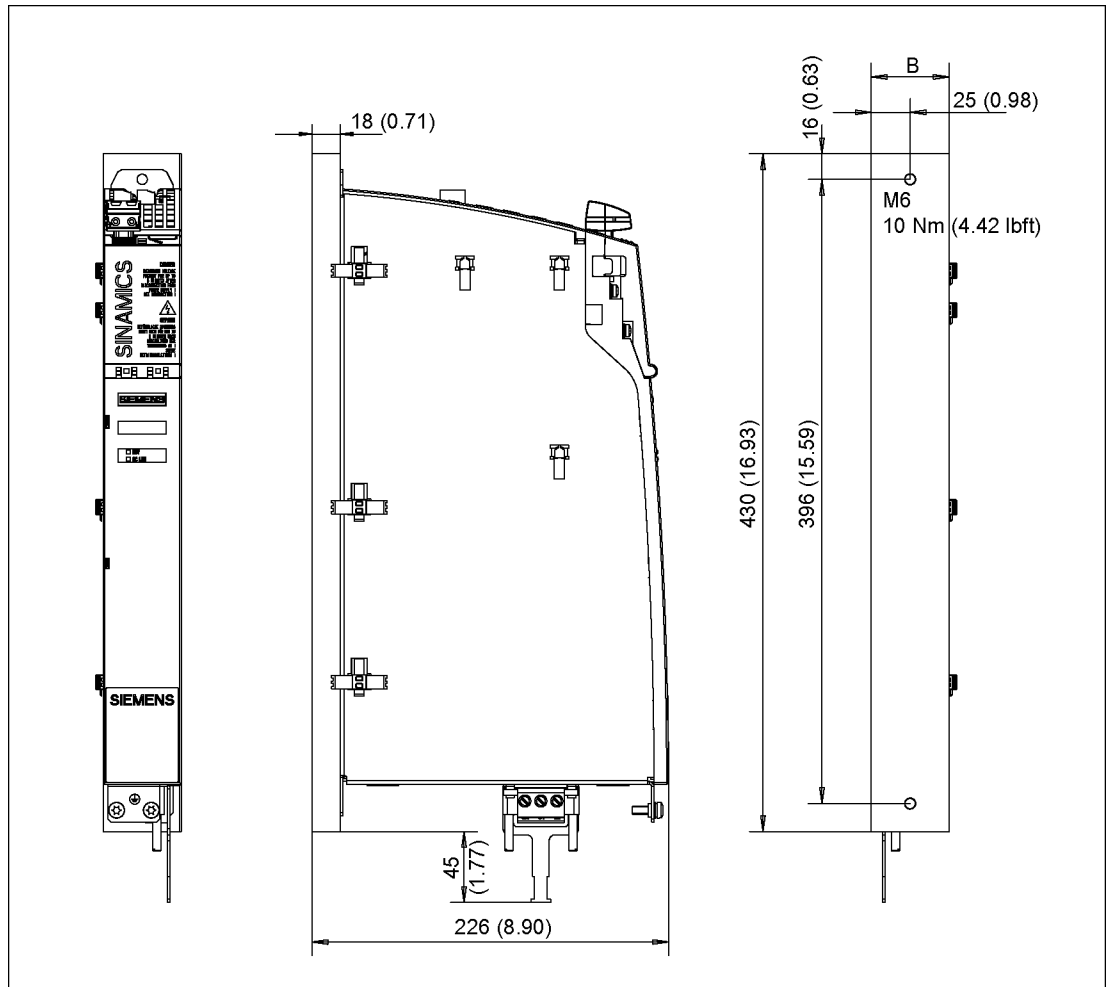

Figure 6-3 Dimension drawing of smart line module with cold plate (10 kW)

Table 6-6 Dimensions of smart line module with cold plate (10 kW)

Line module type	Order number	W [mm] (inches)
5 kW	6SL3136-6AE15-0AAx	50 (1.97)
10 kW	6SL3136-6AE21-0AAx	50 (1.97)

6.5 Installation

Installing the cold-plate modules on customer-specific heat sinks

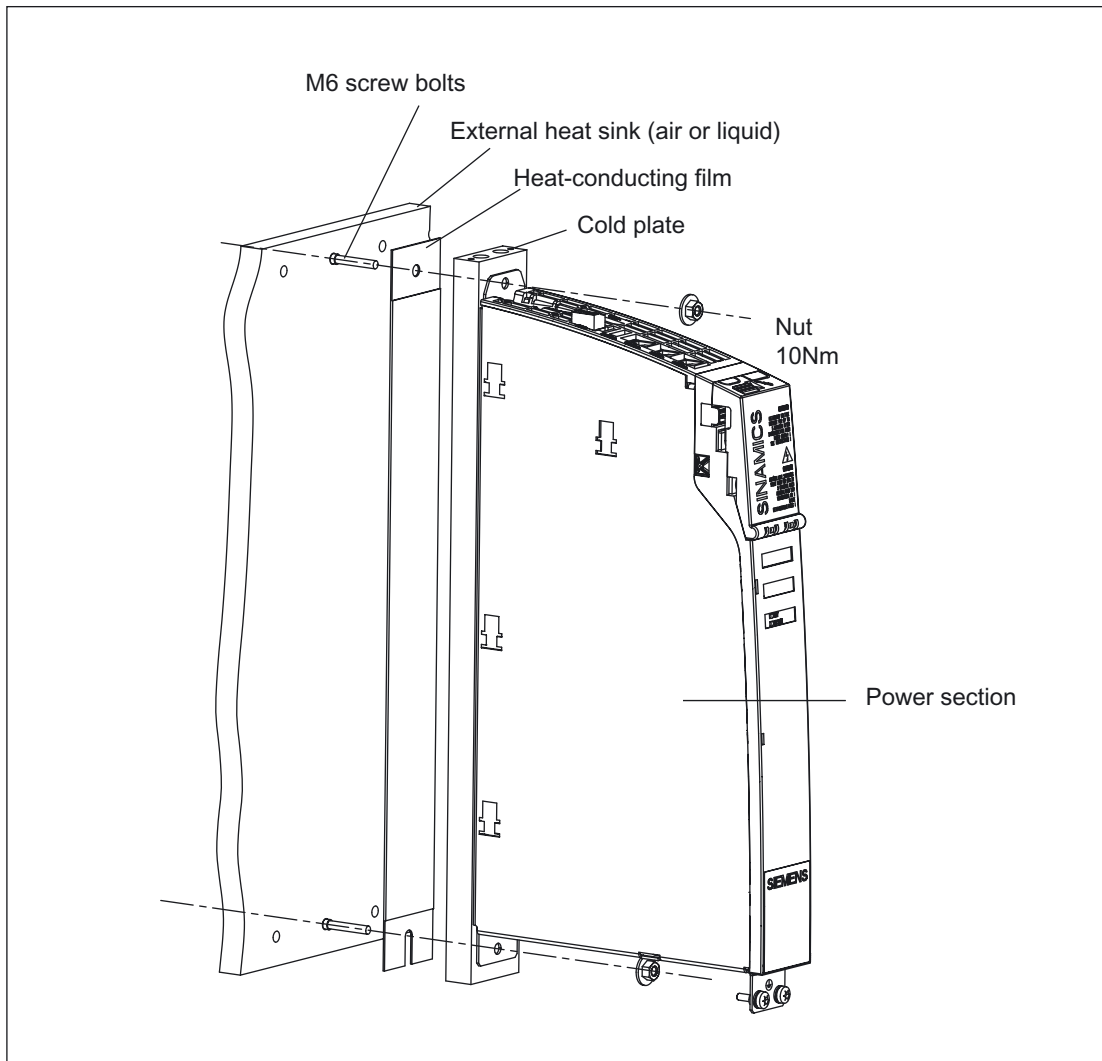

Figure 6-4 Installing a cold-plate power section with an external heat sink

Properties of the heat sink

AlMgSi 0.5 is recommended as the heat sink material.

The roughness of the external heat sink surface should be at least Rz 16 and the contact surface between the heat sink and cold plate should have an evenness of 0.2 mm.

Note

The machine manufacturer can choose the right heat sink version for his special plant requirements. The specified rated data for the Power Modules can only be achieved if the power losses can be dissipated from the external heat sink under the specified general conditions.

Notice

During installation, you must make sure that the threaded bolts do not damage the cold plate.

Installation instructions

1. Before installation, check the surface of the heat sink to ensure that it is not damaged.
2. For installation, M6 screw bolts and hexagon nuts/threaded pins (ISO 7436-M6x40-14 H) are recommended.
3. To improve heat transfer, a heat-conducting medium must be used. Special spherical-indented heat-conducting film must be used for this purpose. Each cold plate power section is supplied with heat-conducting film cut to the right size. Note the installation position of the heat-conducting film (see diagram above). To make it easier to attach the heat-conducting film, the screw bolts/threaded pins should already be inserted in the holes provided on the heat sink.
4. The module is then fitted to the external heat sink.
5. The tightening torque for the screw connection is 10 Nm.

Note

When a module is replaced, the heat-conducting film must also be replaced. Only heat-conducting film approved or supplied by Siemens can be used.

Remove the holder for securing the Control Unit

If an additional component is to be flush-mounted to the left of the component, the holders for securing the Control Unit must be removed.

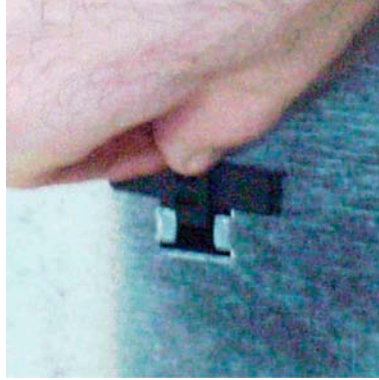
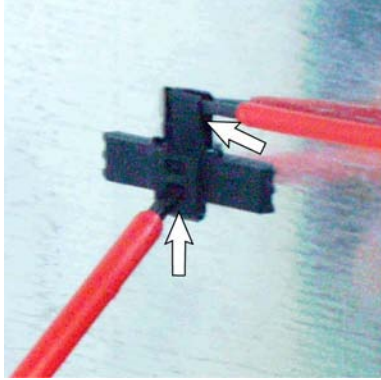

Use suitable tools to lift the latching device and push up the holder.

Remove the holder.

The holder removed

6.6 Technical Specifications

Table 6-7 Technical specifications for Smart Line Modules with cold-plate cooling

	6SL3135-6AE	15-0AAx	21-0AAx
Connection voltages:			
Line voltage	V _{AC}	3AC 380 – 10% to 3AC 480 + 10% (-15% < 1 min)	
Line frequency	Hz	47 to 63	
Electronics power supply	V _{DC}	24 (20.4 – 28.8)	
DC link voltage			
Overvoltage trip threshold	V _{DC}	510 – 750	
	V _{DC}	820 ± 2%	
Undervoltage trip threshold	V _{DC}	360 ± 2%	
DC link busbar current carrying capacity	A _{DC}	100	100
24 V busbar current carrying capacity	A _{DC}	20	20
Rated power	kW	5	10
Power:			
Rated power (S1) ¹	kW (P _n)	5	10
Power rating (S6-40%) ¹	kW (P _{s6})		
Peak power rating ¹	kW (P _{max})	10	20
Regenerative feedback:			
Continuous regenerative power rating	kW	5	10
Peak regenerative power rating	kW	10	20
Supply currents:			
at 380 V _{AC}	A _{AC}	12	24
at 480 V _{AC} / 528 V _{AC}	A _{AC}	9.3 / 8.5	18 / 16.5
at 480 V; S6-40%	A _{AC}	12	24
Peak current (at 400 V _{AC} / 480 V _{AC})	A _{AC}	22 / 18.5	44 / 37
Output currents at 600 V _{DC} :			
Rated current	A _{DC}	8.3	16.6
at S6-40%	A _{DC}	11	22
Peak current	A _{DC}	16.6	33.2
Max. permissible heat sink temperature	°C	60	65
Max. ambient temperature without derating	°C	40	40
Max. ambient temperature with derating	°C	55	55
DC link capacitance	µF	220	330
Charging limit	µF	6000	6000
Power factor	cosφ	1	1
Efficiency	η	0.98	0.98
Weight	kg	4.0	4.0

¹ The specified values are valid for 380 V

Rated duty cycles of Smart Line Modules

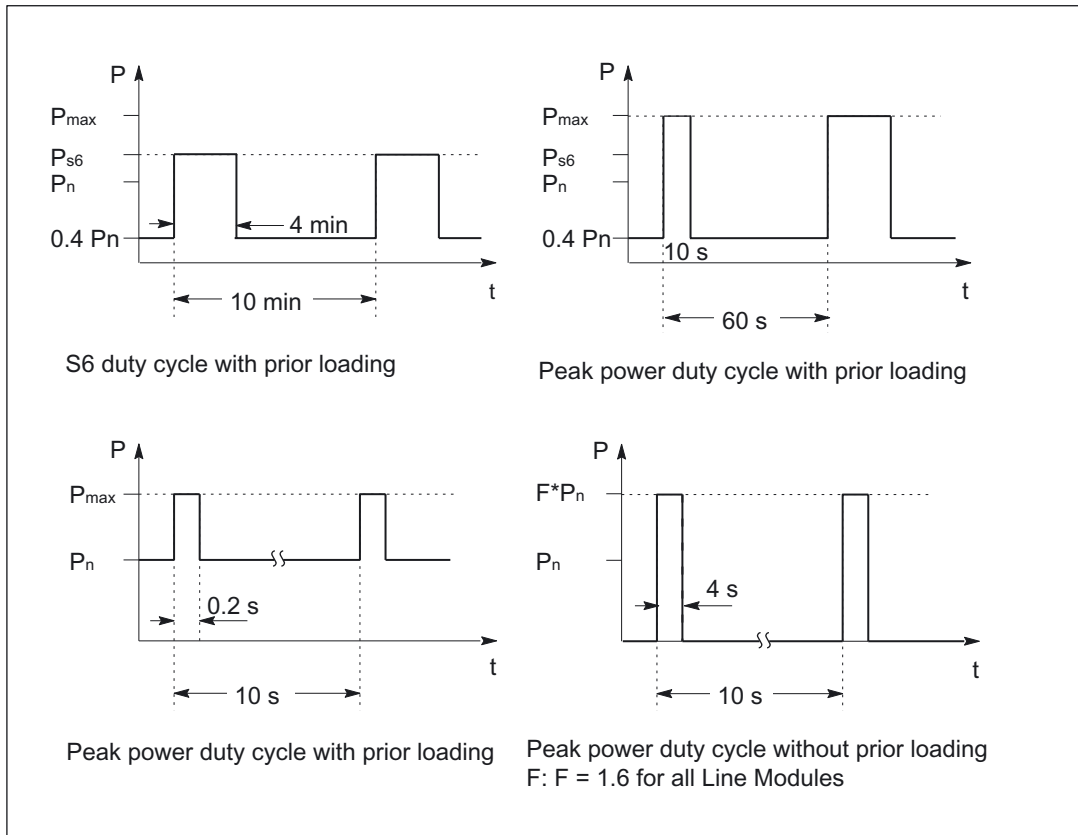

Figure 6-5 Rated duty cycles of Smart Line Modules

Derating as a function of the ambient temperature

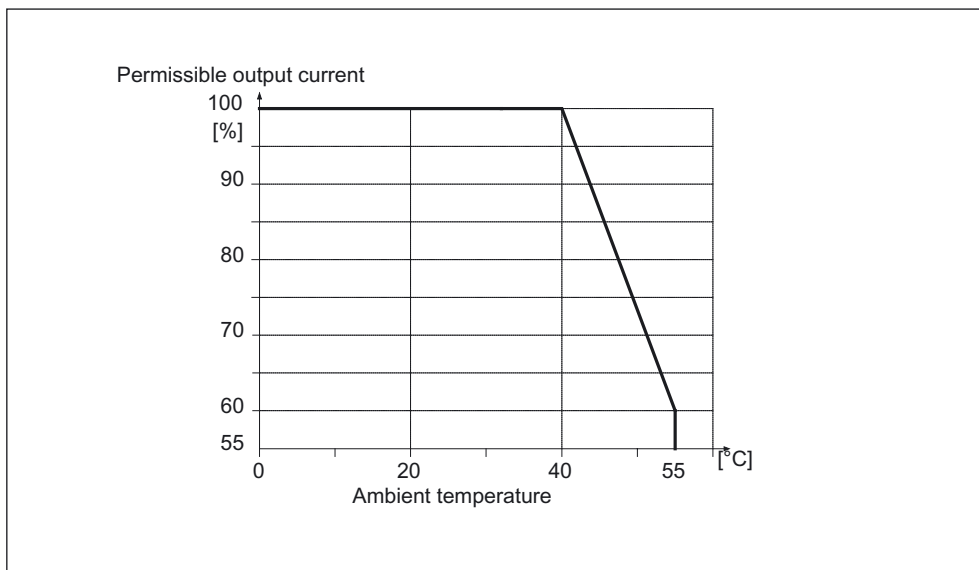

Figure 6-6 Derating as a function of the ambient temperature

Derating as a function of the installation altitude

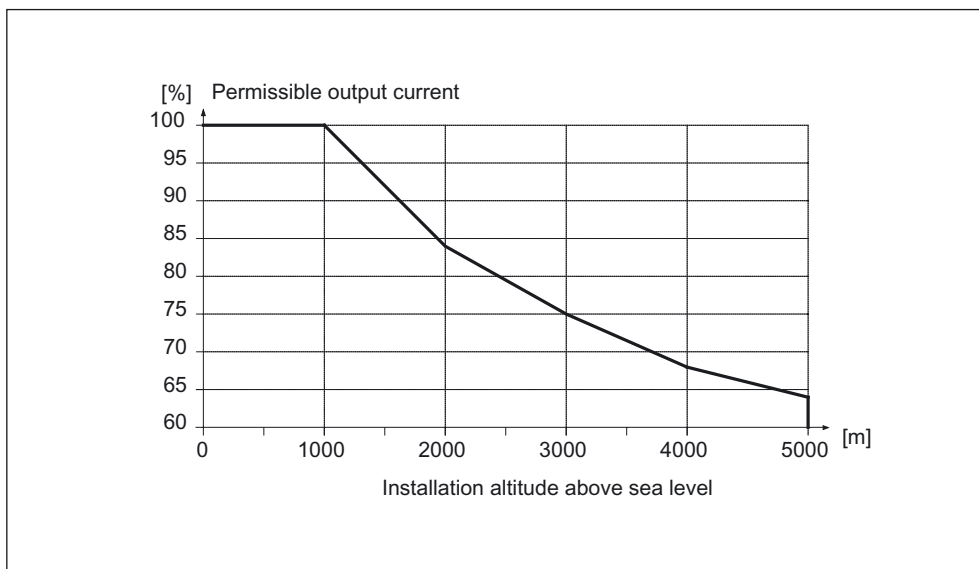

Figure 6-7 Derating as a function of the installation altitude

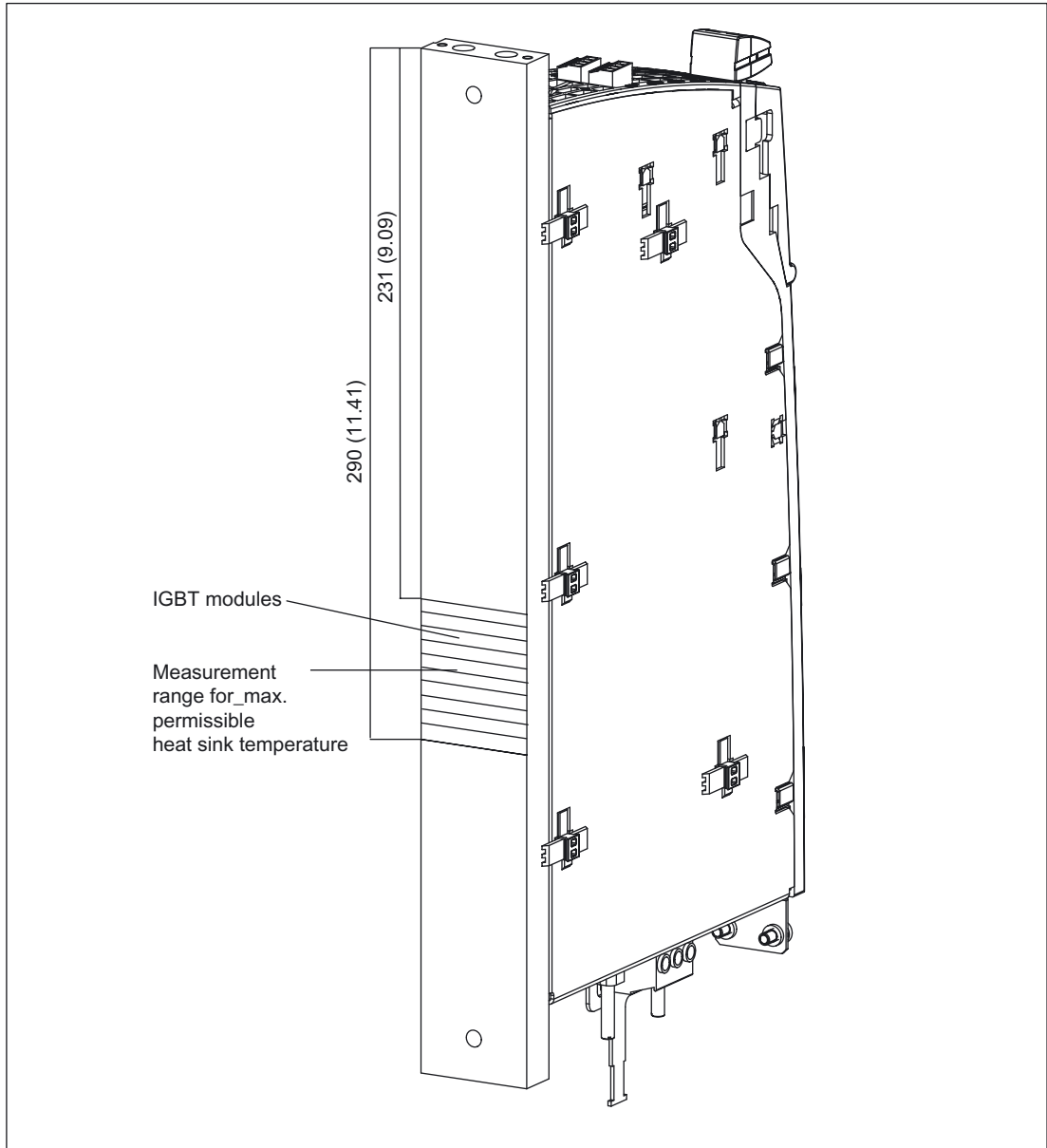

Figure 6-8 Measurement range for max. permissible heat sink temperature for a Smart Line Module

Motor Modules with Cold Plate

7.1 Description

A motor module is a power unit (inverter) that provides the power supply for the connected motor(s). Power is supplied by means of the DC link of the drive unit. A motor module must be connected to a control unit via DRIVE-CLiQ. The open-loop and closed-loop control functions for the motor module are stored in the control unit.

One motor can be connected to single motor modules and two motors can be connected to double motor modules.

7.2 Safety Information



Danger

Only motors with a safe electrically isolated holding brake may be connected. The brake conductors must also be safely electrically isolated.

If the motor power cable is connected to intermediate terminals, the power cables and brake cables must be routed apart (≥ 300 mm).



Warning

After disconnecting all the supply voltages, a hazardous voltage will be present in all components for another 5 minutes. The protective cover must not be opened until this time has elapsed.

When opening the protective cover for the DC link, you must activate the release. A suitable tool (e.g. screwdriver) must be used for this purpose.

The components must only be operated when the protective cover of the DC link is closed. Damaged components must not be used, otherwise this could result in secondary damage or accidents.



Caution

Motor Modules with a rated current as of 18 A and all Double Motor Modules conduct a high leakage current via the PE conductor. Because of the high leakage current of the Motor Modules, a permanent PE connection of the Motor Module or switching cabinet is required.

Measures according to EN 61800-5-1 must be taken (e.g. PE conductor ($\geq 10\text{mm}^2$ Cu) or fit an additional connection terminal for a PE conductor with the same cross-section as the original PE conductor).



Caution

The DC link discharge voltage hazard warning must be affixed to the modules in the local language.

A set of labels in 12 languages is available using order number: 6SL3166-3AB00-0AAx.

Notice

The 80 mm clearances above and below the components must be observed.

Caution

The tightening torque of the DC link busbar screws (1.8 Nm, tolerance: +30%) must be checked before startup. After transportation, the screws must be tightened.



Warning

Cable shields and unused power cable conductors (e.g. brake conductors) must be connected to PE potential to prevent capacitive cross-talk charges. Non-observance can cause lethal shock voltages.

Caution

Only cables from Siemens must be used for DRIVE-CLiQ connections.

Note

A regulated DC power supply is required to operate motors with a built-in holding brake. The voltage is supplied via the internal 24 V busbars. The voltage tolerances of the motor holding brakes and the voltage drops of the connection cables must be taken into account.

The DC power supply should be set to 26 V. This ensures that the voltage supply for the brake remains within the permissible range when the following conditions are fulfilled:

- Using Siemens three-phase motors
 - Using Siemens MOTION-CONNECT power cables
 - Motor cable lengths: max. 100 m
-

Caution

The left and right ends of the DC link busbar of a drive line-up must be fitted with peripheral covers (order no.: 6SL3162-5AA00-0AA0).

7.3 Interface description

7.3.1 Overview

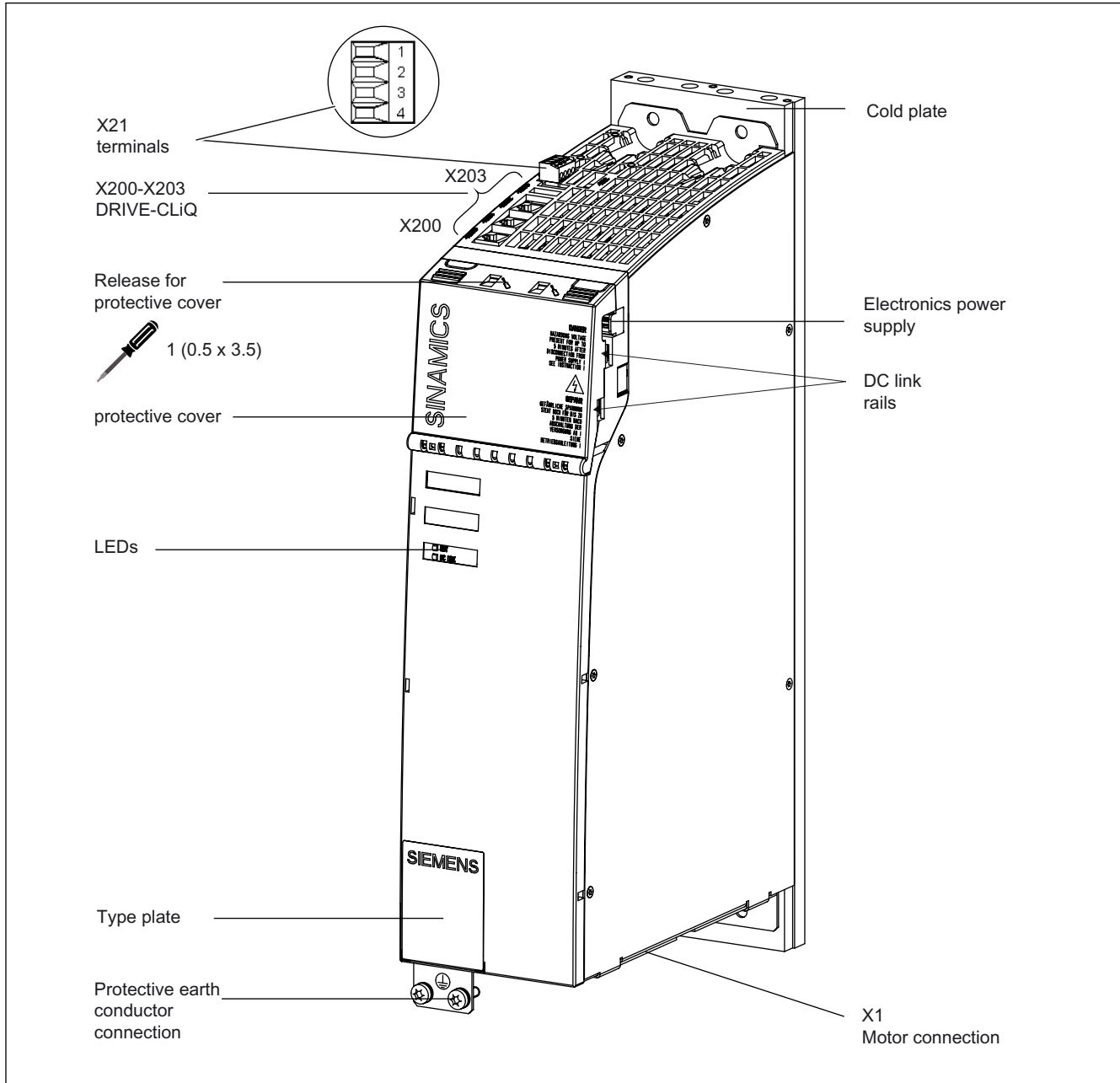

Figure 7-1 Single motor module with cold plate (example 30 A)

7.3.2 Connection Examples

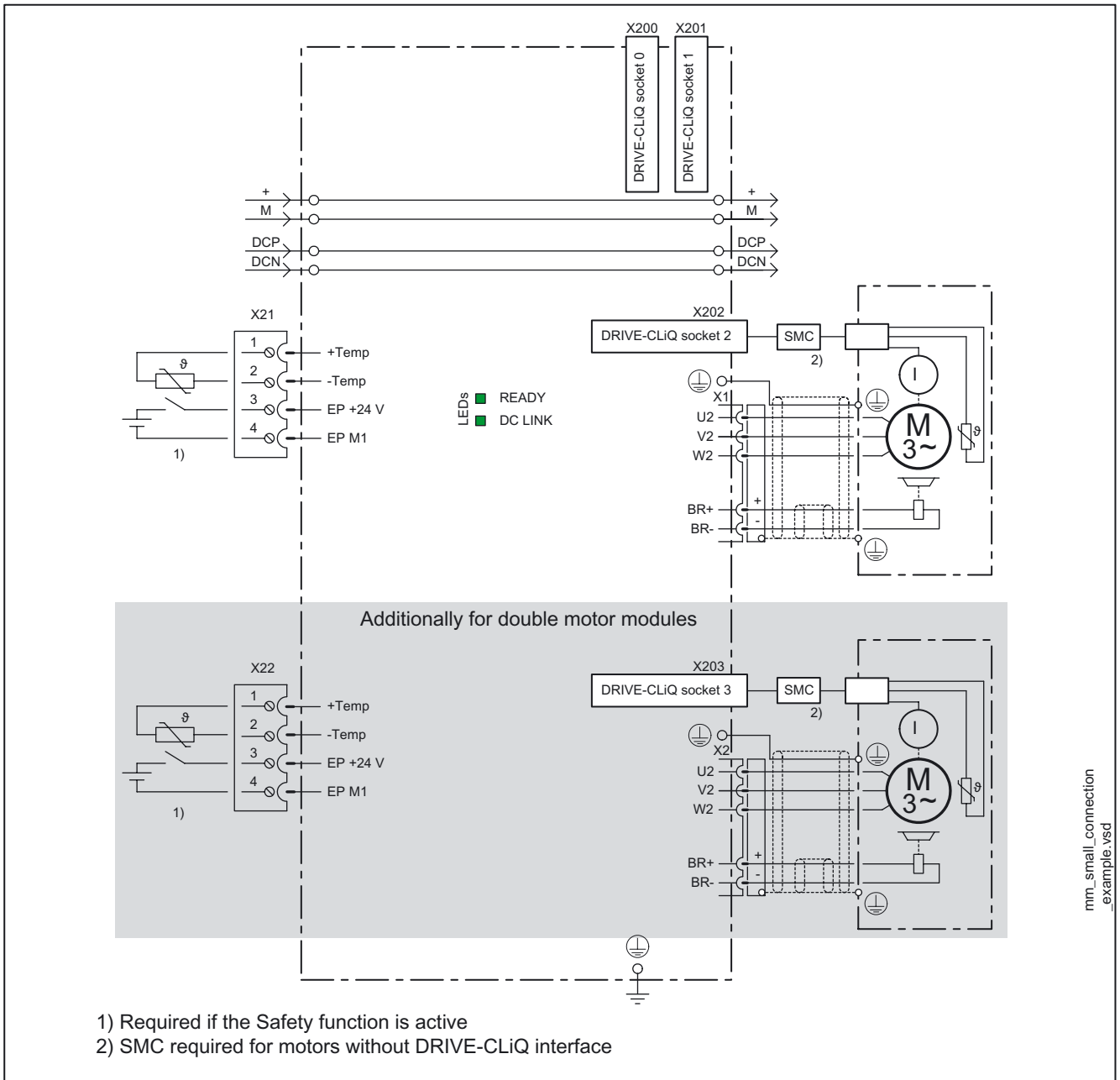

Figure 7-2 Connection example of Motor Modules 3 A to 30 A and 2x3 A to 2x18 A

7.3 Interface description

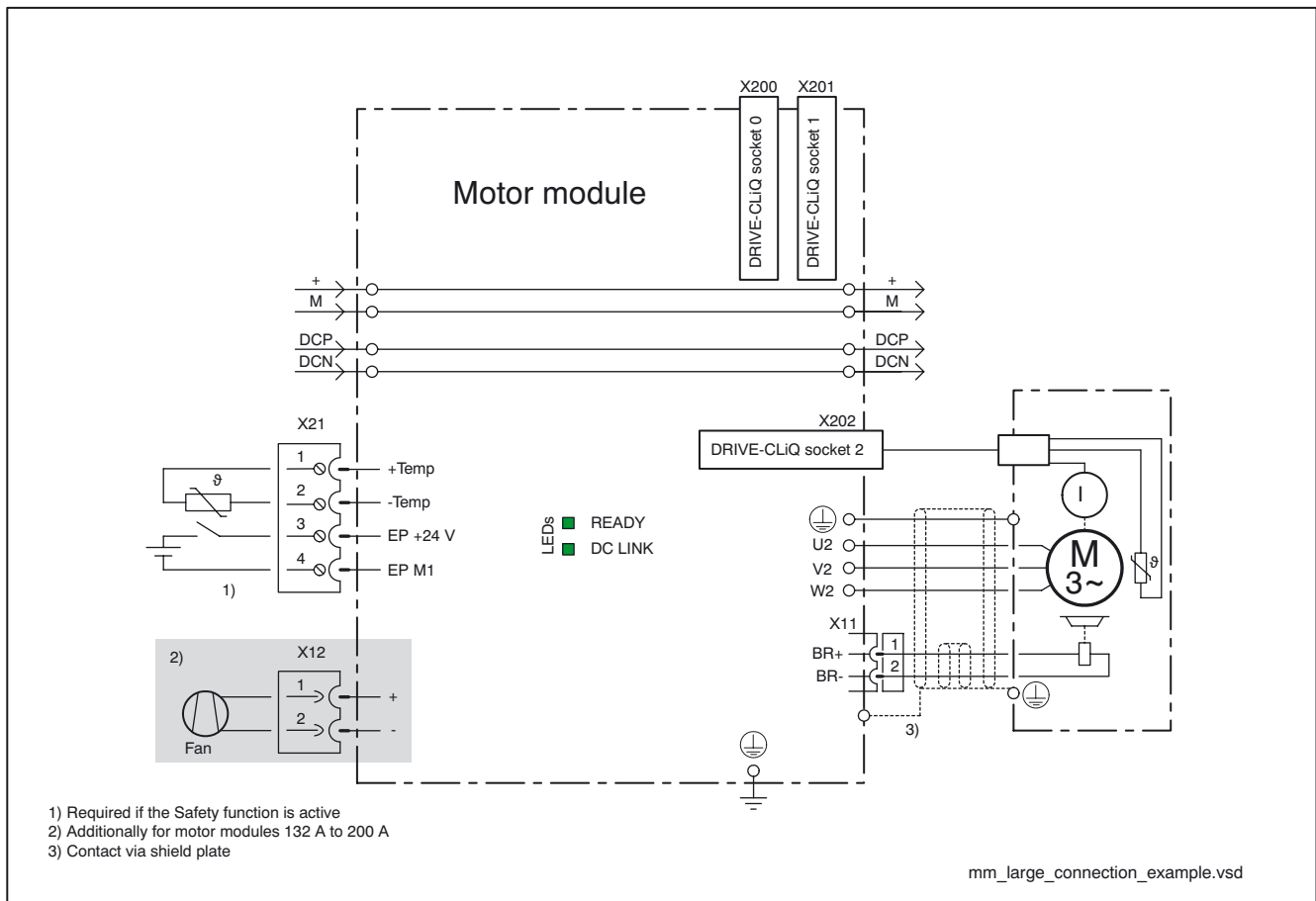

Figure 7-3 Connection example of Single Motor Modules 45 A to 200 A

7.3.3 Motor/brake connection

Table 7-1 Terminal block X1/X2 Motor Modules 3 A to 30 A and 2x3 A to 2x18 A

	Terminal	Technical specifications
	U (U2)	Motor connection
	V (V2)	
	W (W2)	
	+ (BR+)	Brake connection
	- (BR-)	
	PE connection	Threaded hole M5/3 Nm ¹

¹ for ring cable lugs to DIN 46234

Table 7-2 Terminal block Single Motor Module 45 A to 200 A

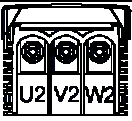
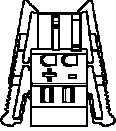
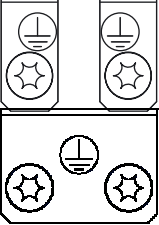
	Terminals	Technical specifications
	U2 V2 W2	45 A to 60 A: Threaded bolt M6/6 Nm ¹⁾ 85 A: Threaded bolt M8/13 Nm ¹⁾ 132 A to 200 A: Threaded bolt M8/13 Nm ¹⁾
	+ (BR+) - (BR-)	X11 brake connector ²⁾ : Voltage: 24 V DC Max. load current: 2 A Min. load current: 0.1 A Max. connectable cross-section: 2.5 mm ² Type: Spring-loaded terminal 2 (see Connection Methods) Manufacturer: Wago; order number: 721-102/026-000/56-000 The brake connector is part of the prefabricated cable.
	PE connection	Single Motor Module with a rated output current of 45 A to 60: Threaded bolt for motor cables: M6/6 Nm ¹⁾ Threaded hole for PE: M6/6 m ¹⁾ Single Motor Module with a rated output current of 85 A Threaded bolt for motor cables: M8/13 Nm ¹⁾ Threaded hole for PE: M6/6 Nm ¹⁾ Single Motor Module with a rated output current of 132 A to 200 A Threaded bolt for motor cables: M8/13 Nm ¹⁾ Threaded hole for PE: M8/6 Nm ¹⁾

¹⁾ For ring cable lugs to DIN 46234

²⁾ The circuit for protecting the brakes against overvoltage is in the Motor Module and does not need to be installed externally. The max. load current is 2 A, the min. load current 0.1 A.

Note

The total length of the shielded power cables (motor supply cables and DC link cables) must not exceed 350 m.

Note

The motor brake must be connected via connector X11. The BR- cable must not be connected directly to electronic ground (M).



Warning

Only protective extra-low voltages (PELVs) that comply with EN60204-1 must be connected to all connections and terminals between 0 and 48 V DC.

The voltage tolerances of the motor holding brakes must be taken into account.

7.3 Interface description

7.3.4 X21/X22 EP terminals/temperature sensor connection for motor module with cold plate

Table 7-3 Terminal block X21/X22

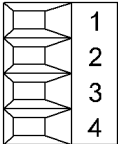
	Terminal	Function	Technical specifications
	1	+Temp	Temperature sensor connection KTY84–1C130
	2	-Temp	
	3	EP +24 V (Enable Pulses)	Supply voltage: 24 V DC (20.4 V - 28.8 V) Current consumption: 10 mA Isolated input Signal propagation times: L → H: 100 μs H → L: 1000 μs
	4	EP M1 (Enable Pulses)	
Max. connectable cross-section 1.5 mm ² Type: Screw terminal 1 (see Appendix A)			

Notice

The KTY temperature sensor must be connected with the correct polarity.

Note

The temperature sensor connection is required for motors where the temperature value is not transmitted via DRIVE-CLiQ.

If the Safety function is active, 24 V DC must be connected to terminal 3 and ground to terminal 4. When removed, pulse inhibit is activated (if this has been parameterized).

7.3.5 X200-X203 DRIVE-CLiQ interface

Table 7-4 DRIVE-CLiQ interface X200-X202: single motor module
DRIVE-CLiQ interface X200-X203: double motor module

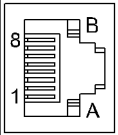
	Pin	Name	Technical specifications
	1	TXP	Transmit data +
	2	TXN	Transmit data -
	3	RXP	Receive data +
	4	Reserved, do not use	
	5	Reserved, do not use	
	6	RXN	Receive data -
	7	Reserved, do not use	
	8	Reserved, do not use	
	A	+ (24 V)	Power supply
	B	GND (0 V)	Electronic ground

Blanking plate for DRIVE-CLiQ interface: Molex, order number: 85999-3255

7.3.6 Meaning of the LEDs on the motor module

Table 7-5 Meaning of the LEDs on the Motor Module

LED	Color	State	Description
READY	-	OFF	Electronics power supply outside permissible tolerance range.
	Green	Continuous	The component is ready for operation and cyclic DRIVE-CLiQ communication is taking place.
	Orange	Continuous	DRIVE-CLiQ communication is being established.
	Red	Continuous	At least one fault is present in this component.
	Green Red	Flashing 2 Hz	Firmware is being downloaded.
	Green/Orange or Red/Orange	Flashing 2 Hz	Component recognition via LED is activated (p0124). Note: Both options depend on the LED status when module recognition is activated via p0124 = 1.
DC LINK	-	OFF	Electronics power supply outside permissible tolerance range.
	Orange	Continuous	DC link voltage within permissible tolerance range (only when ready for operation)
	Red	Continuous	DC link voltage outside permissible tolerance range (only when ready for operation)

Cause and rectification of faults

The following reference contains information about the cause and rectification of faults:

Reference: //IH1/ SINAMICS S120 Commissioning Manual

7.4 Dimension Drawing

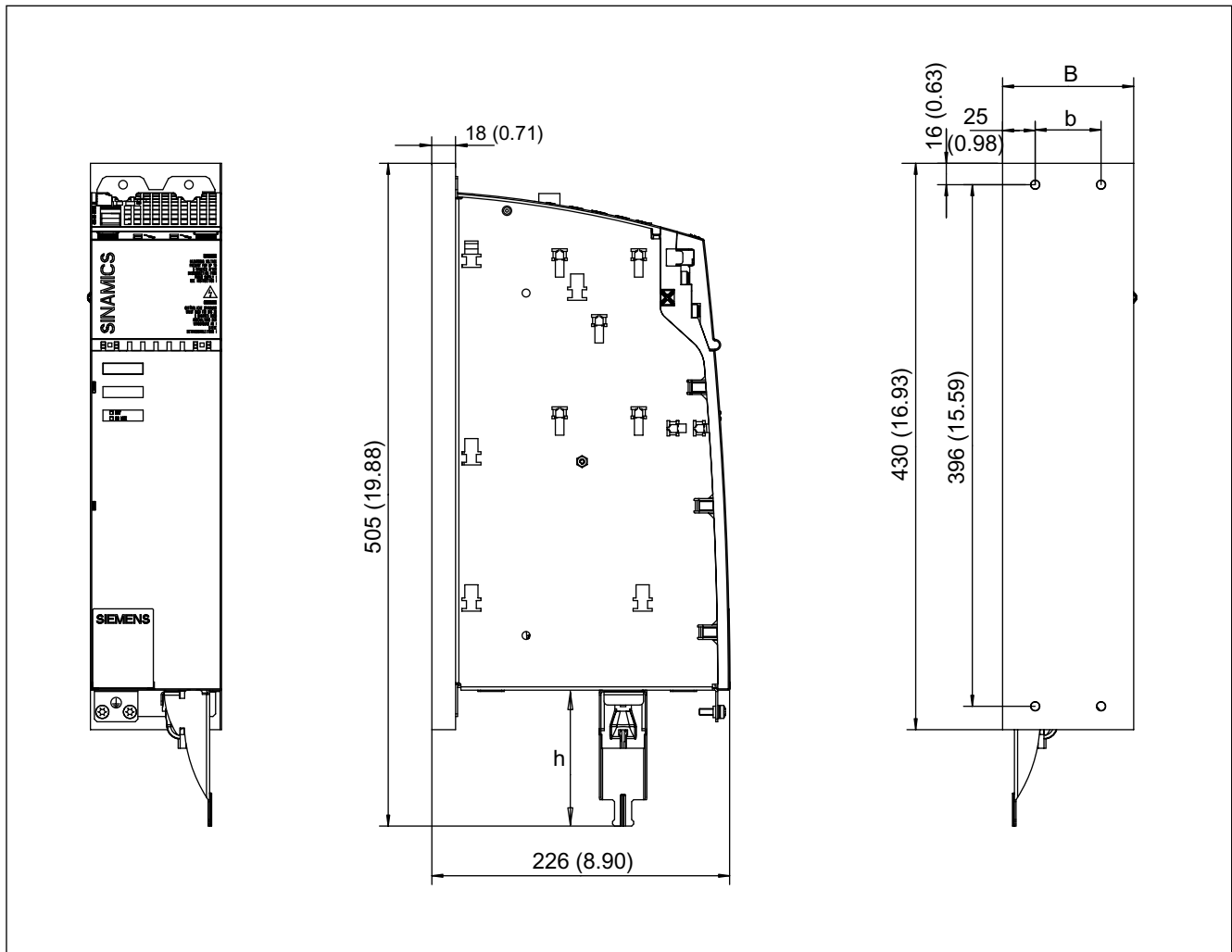

Figure 7-4 Dimension drawing of Motor Module with cold plate (18 A and 30 A)

Table 7-6 Dimensions of Motor Module with cold plate (18 A and 30 A)

Motor Module type	Order number	W [mm] (inches)	w [mm] (inches)	h [mm] (inches)
LT Compact 1 axis 400 V DC 18 A 50 mm	6SL3126-1TE21-8AAx	50 (1.97)	-	89 (3.50)
LT Compact 1 axis 400 V DC 30 A 100 mm	6SL3126-1TE23-0AA0	100 (3.94)	50 (1.97)	89 (3.50)
LT Compact 2 axis 400 V DC 18 A 100 mm	6SL3126-2TE21-8AA0	100 (3.94)		89 (3.50)

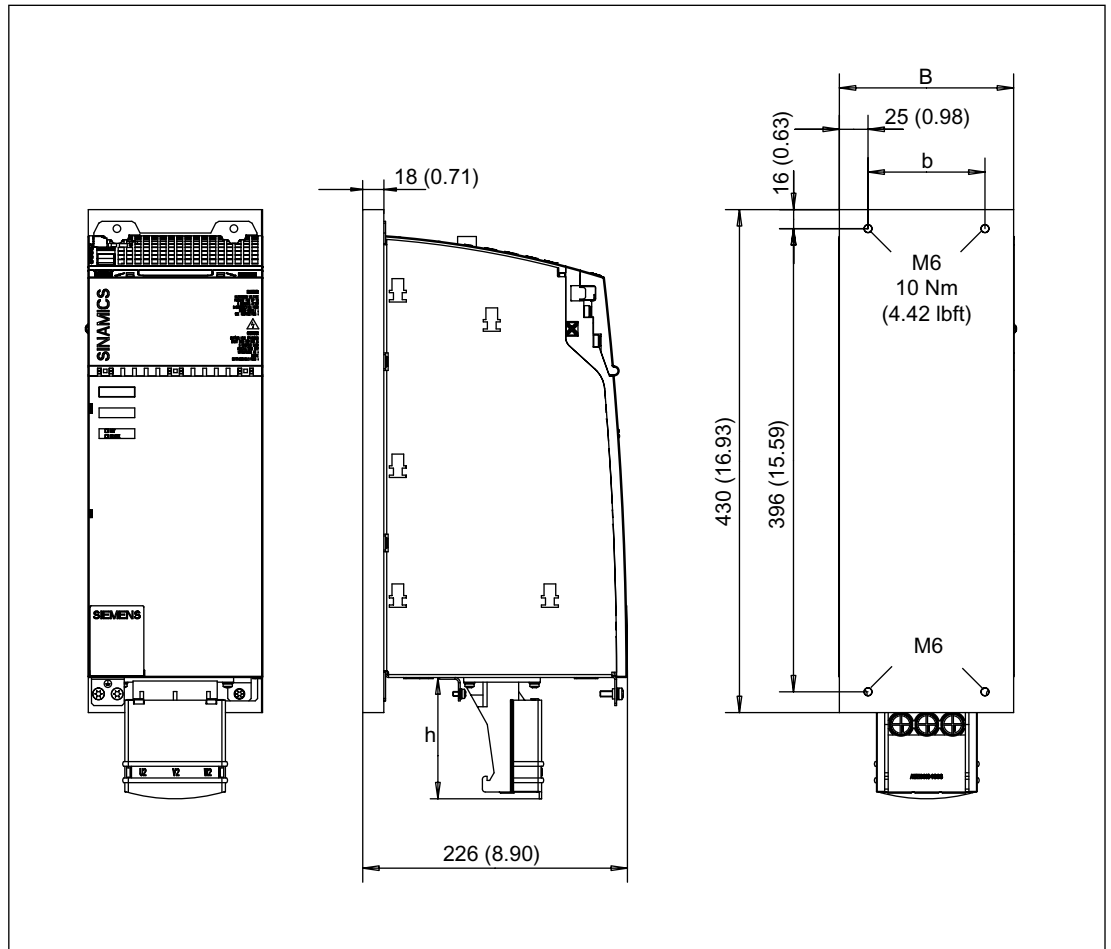

Figure 7-5 Dimension drawing of Motor Module with cold plate (60 A and 85 A)

Table 7-7 Dimensions of Motor Module with cold plate (60 A and 85 A)

Motor Module type	Order number	W [mm] (inches)	w [mm] (inches)	h [mm] (inches)
LT Compact 1 axis 400 V DC 60 A 150 mm	6SL3126-1TE26-0AAx	150 (5.91)	100 (3.94)	89 (3.50)
LT Compact 1 axis 400 V DC 85 A 200 mm	6SL3126-1TE28-5AAx	200 (7.87)	150 (5.91)	89 (3.50)

7.5 Installation

Installing the cold-plate modules on customer-specific heat sinks

Note the following before installation:

- Before installation, check the surface of the heat sink to ensure that it is not damaged.
- To facilitate installation, M6 screw bolts and hexagon nuts/threaded pins (ISO 7436-M6x40-14 H, strength class 8.8) are recommended.
- To improve heat transfer, a heat-conducting medium must be used. Special spherical-indented heat-conducting film must be used for this purpose. Each cold plate power section is supplied with heat-conducting film cut to the right size. Note the installation position of the heat-conducting film (see diagram below).

Note

When a module is replaced, the heat-conducting film must also be replaced. Only heat-conducting film approved or supplied by Siemens can be used.

Installation

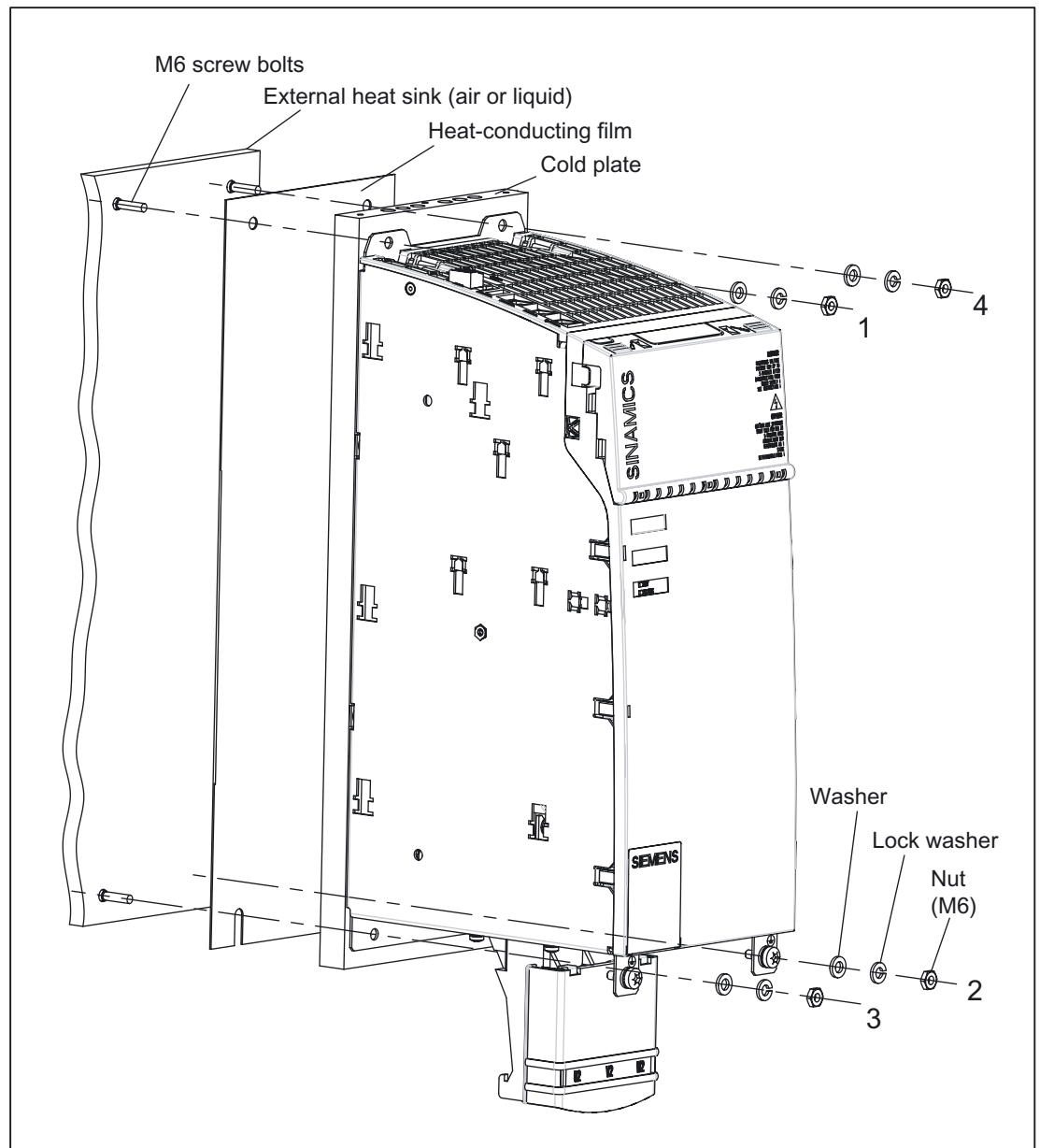

Figure 7-6 Installing a cold-plate power section with an external heat sink and heat-conducting film

To begin, tighten the screws by hand (approx. 0.5 Nm) in the sequence shown (steps 1 to 4) and then secure them (10 Nm).

Properties of the heat sink

AlMgSi 0.5 is recommended as the heat sink material.
The roughness of the external heat sink surface should be at least Rz 16 and the contact surface between the heat sink and cold plate should have an evenness of 0.2 mm (applicable to a height of 450 mm and width of 300 mm).

Note

The machine manufacturer can choose the right heat sink version for his special plant requirements. The specified rated data for the Power Modules can only be achieved if the power losses can be dissipated from the external heat sink under the specified general conditions.

Notice

During installation, you must make sure that the threaded bolts do not damage the cold plate.

Remove the holder for securing the Control Unit

If an additional component is to be flush-mounted to the left of the component, the holders for securing the Control Unit must be removed.

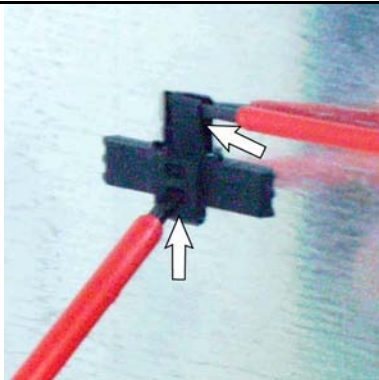

Use suitable tools to lift the latching device and push up the holder.

Remove the holder.

The holder removed

7.6 Technical Specifications

Table 7-8 Technical specifications for Motor Modules with cold-plate cooling (3 A - 30 A)

	6SL3126-1TE	13-0AA0	15-0AA0	21-0AA0	21-8AA0	23-0AA0
Voltage						
Power supply: DC link voltage Electronics power supply Output voltage	V _{DC} V _{DC} V _{ACrms}	510 –750 24 (20.4 – 28.8) 0 - 0.67 x DC link voltage				
Overvoltage tripping Undervoltage tripping	V _{DC} V _{DC}	820 ± 2% 380				
Electronics current consumption at 24 V	A _{DC}	See Cabinet Design and EMC				
DC link busbar current carrying capacity	A _{DC}	100	100	100	100	100
24 V busbar current carrying capacity	A _{DC}	20	20	20	20	20
Rated output current	A _{ACrms(In)}	3	5	9	18	30
Base load current I _{base}	A	2.6	4.3	7.7	15.3	25.5
Intermittent duty current I _{S6} 40%	A _{ACrms(Is6)}	3.5	6	10	24	40
Peak current	A _{ACrms(I_{max})}	6	10	18	36	56
Rated power (with DC link voltage of 600 V _{DC} and clock frequency of 4 kHz)	kW	1.6	2.7	4.8	9.7	16
Max. pulse frequency without derating	kHz	4				
Max. pulse frequency with derating	kHz	16				
Max. permissible heat sink temperature	°C	70	70	70	75	70
Max. ambient temperature without derating	°C	40				
Max. ambient temperature with derating	°C	55				
DC link capacitance	µF	110	110	110	220	710
Efficiency η (4 kHz)		0.97	0.97	0.97	0.97	0.97
Weight	kg	4.2	4.2	4.5	4.5	6.1

7.6 Technical Specifications

Table 7-9 Technical specifications for Motor Modules with cold-plate cooling (45A - 200A)

	6SL3126-1TE	24-5AA0	26-0AA0	28-5AA0	31-3AA0 ¹⁾	32-0AA0 ¹⁾
Voltage						
Power supply: DC link voltage Electronics power supply Output voltage	V _{DC} V _{DC} V _{ACrms}	510 –750 24 (20.4 – 28.8) 0 - 480				
Overvoltage tripping Undervoltage tripping	V _{DC} V _{DC}	820 ± 2% 380				
Electronics current consumption at 24 V	A _{DC}	See "Booksize Cabinet Design"				
DC link busbar current carrying capacity	A _{DC}	100	100	200	200	200
24 V busbar current carrying capacity	A _{DC}	20	20	20	20	20
Rated output current	A _{ACrms(In)}	45	60	85	132	200
Base load current I _{base}	A	38	51	68	105	141
Intermittent duty current I _{s6} 40%	A _{ACrms(Is6)}	60	80	110	150	250
Peak current	A _{ACrms(I_{max})}	85	113	141	210	282
Rated power (with DC link voltage of 600 V _{DC} and clock frequency of 4 kHz)	kW	24	32	46	71	107
Max. pulse frequency without derating	kHz	4				
Max. pulse frequency with derating	kHz	16				
Max. permissible heat sink temperature	°C	75	70	78	70	75
Max. ambient temperature without derating	°C	40				
Max. ambient temperature with derating	°C	55				
DC link capacitance	µF	1175	1410	1880	2820	3995
Efficiency η (4 kHz)		0.97	0.97	0.97	0.97	0.97
Weight	kg	9.1	9.1	12.5	18.0	18.0

¹⁾ The specified rated power values/currents can only be achieved if direct liquid cooling is used. Derating will occur if installed on an external heat sink. At a temperature of 40°C at the interface to the power section, 80% derating occurs for 6SL3126-1TE31-3AA0 and 70% for 6SL3126-1TE32-0AA0.

Table 7-10 Technical specifications for Double Motor Modules with cold-plate cooling (2x3 to 2 x 18A)

	6SL3126-2TE	13-0AA0	15-0AA0	21-0AA0	21-8AA0
Voltage					
Power supply: DC link voltage Electronics power supply Output voltage	V_{DC} V_{DC} V_{ACrms}	510 –750 24 (20.4 – 28.8) 0 - 480			
Overvoltage tripping Undervoltage tripping	V_{DC} V_{DC}	820 ± 2% 380			
Electronics current consumption at 24 V	A_{DC}	See "Booksize Cabinet Design"			
DC link busbar current carrying capacity	A_{DC}	100	100	100	100
24 V busbar current carrying capacity	A_{DC}	20	20	20	20
Rated output current	$A_{ACrms(I_n)}$	2x3	2x5	2x9	2x18
Base load current I_{base}	A	2x2.6	2x4.3	2x7.7	2x15.3
Intermittent duty current I_{S6} 40%	$A_{ACrms(I_{S6})}$	2x3.5	2x6	2x10	2x24
Peak current	$A_{ACrms(I_{max})}$	2x6	2x10	2x18	2x36
Rated power (with DC link voltage of 600 V_{DC} and clock frequency of 4 kHz)	kW	1.6	2.7	4.8	9.7
Max. pulse frequency without derating	kHz	4			
Max. pulse frequency with derating	kHz	16			
Max. permissible heat sink temperature	°C	75	75	85	80
Max. ambient temperature without derating	°C	40			
Max. ambient temperature with derating	°C	55			
DC link capacitance	µF	110	220	220	705
Efficiency η (4 kHz)		0.97	0.97	0.97	0.97
Weight	kg	4.5	4.5	4.5	5.9

Rated duty cycles of Motor Modules booksize

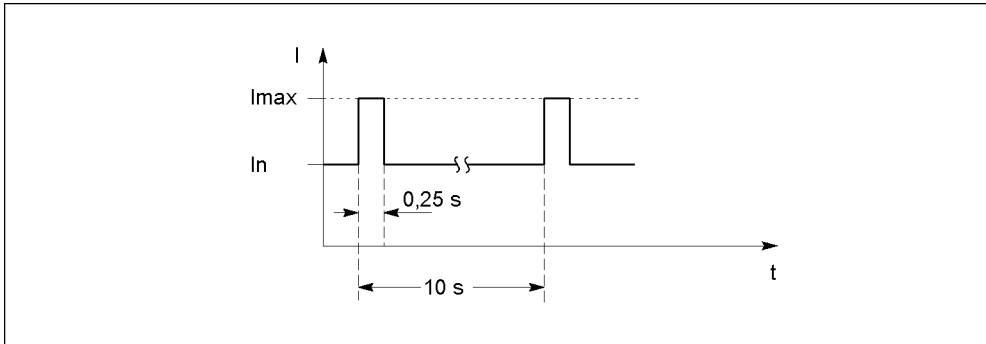

Figure 7-7 Peak current duty cycle with prior loading

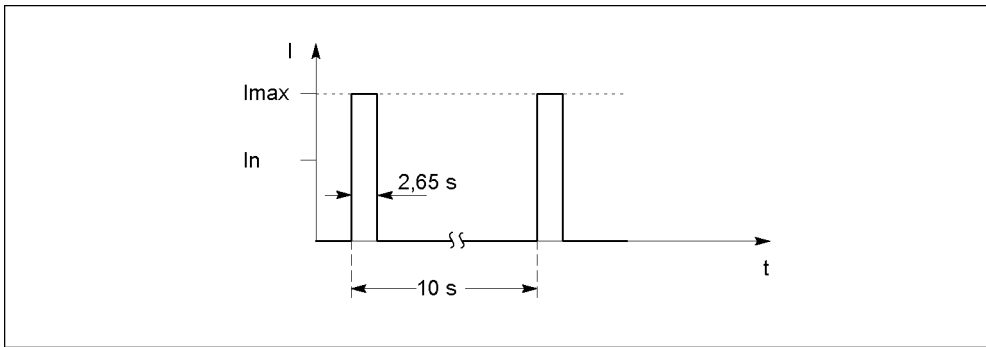

Figure 7-8 Peak current duty cycle without prior loading

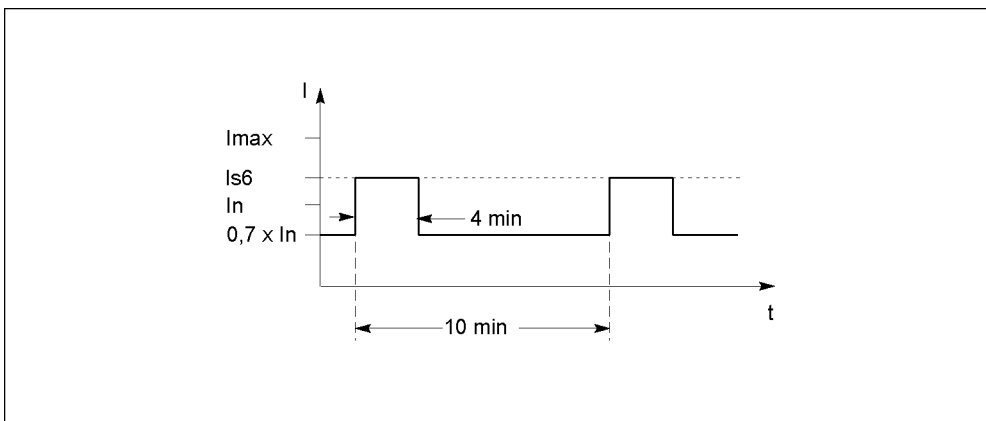

Figure 7-9 S6 current duty cycle with prior loading

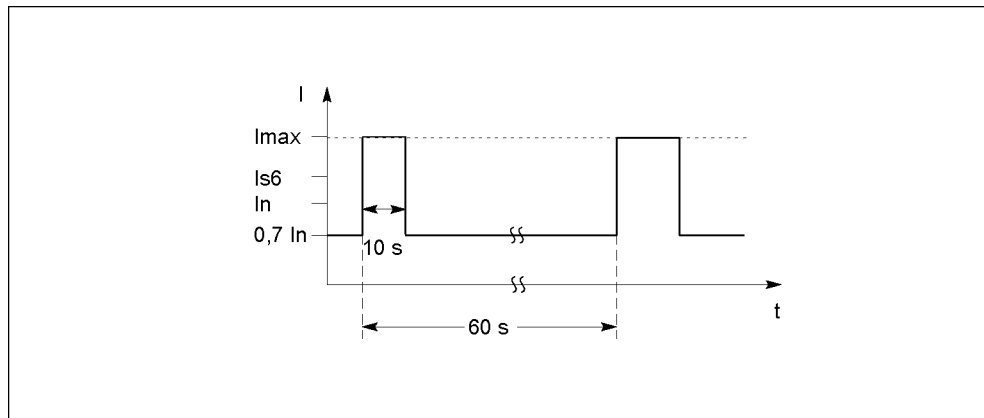

Figure 7-10 S6 peak current duty cycle with prior loading

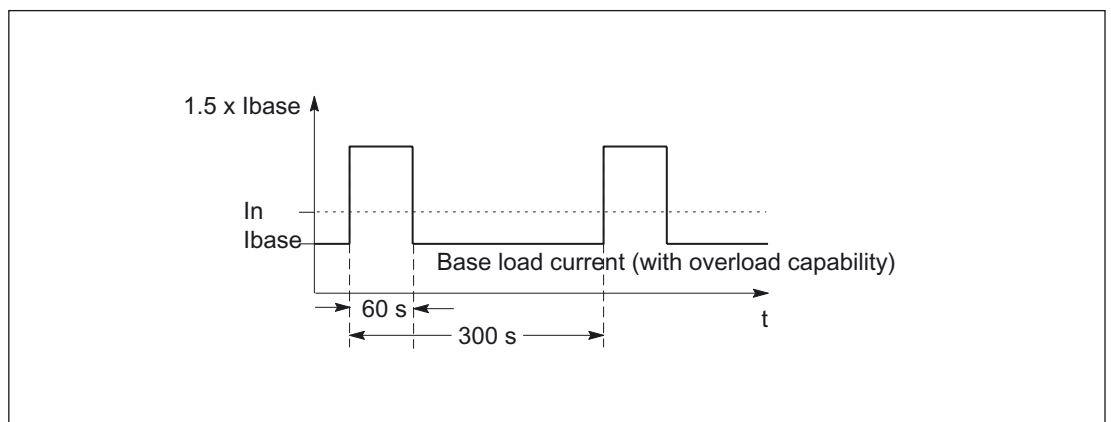

Figure 7-11 Current duty cycle with prior loading

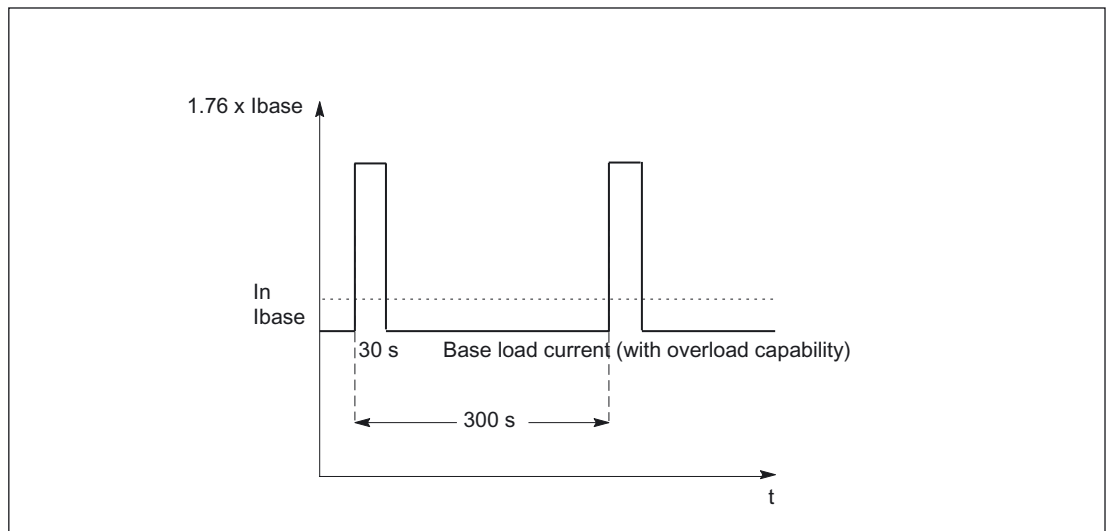

Figure 7-12 Current duty cycle with prior loading

Derating as a function of the ambient temperature

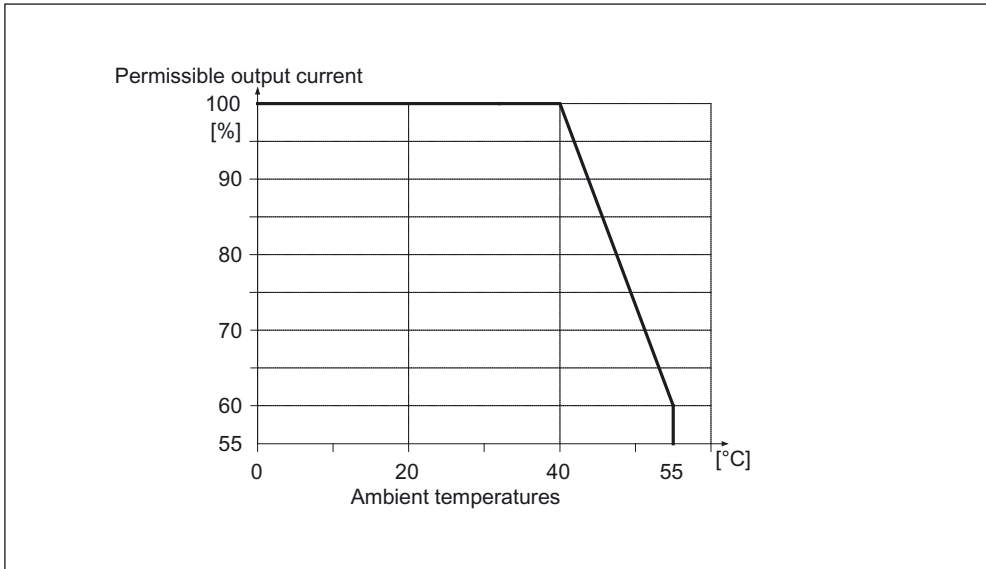

Figure 7-13 Derating as a function of the ambient temperature

Derating as a function of the pulse frequency

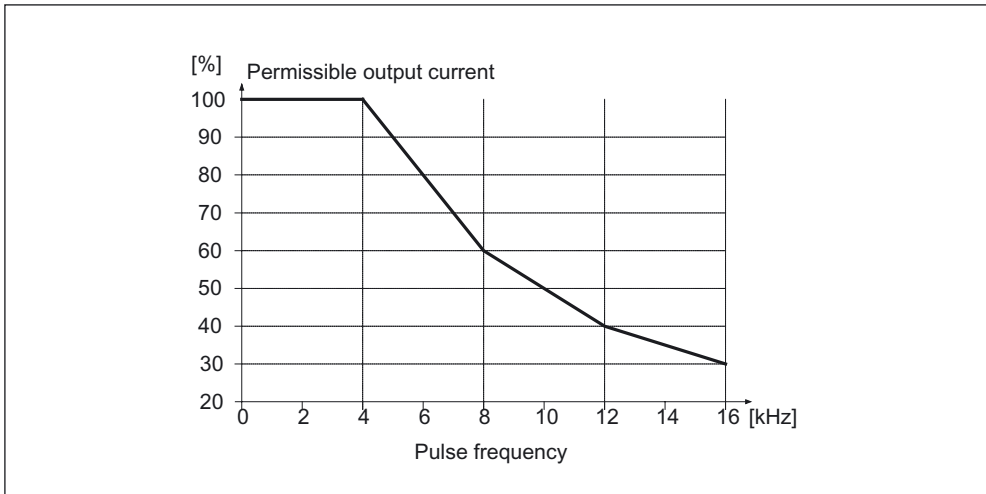

Figure 7-14 Derating as a function of the pulse frequency

Derating as a function of the installation altitude

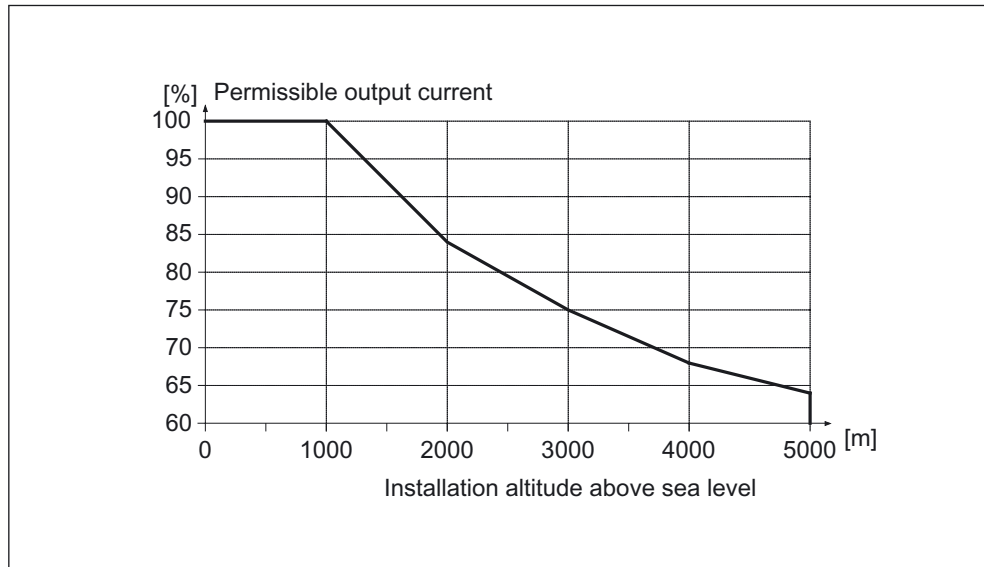

Figure 7-15 Derating as a function of the installation altitude

Connection adapter

8.1 Description

Connection adapter allow cooling water hoses to be attached to the cold plate. A connection adapter with a molded seal is attached to the top and bottom of the cold plate. The connection adapter is made of aluminum and has threads for attaching conventional hose connections.

8.2 Safety Information



Caution

The module with a cold plate cannot be operated without internal liquid cooling or external cooling.

Note

The information provided in "Cabinet Design" about connecting the water must be taken into account.

8.3 Dimension Drawing

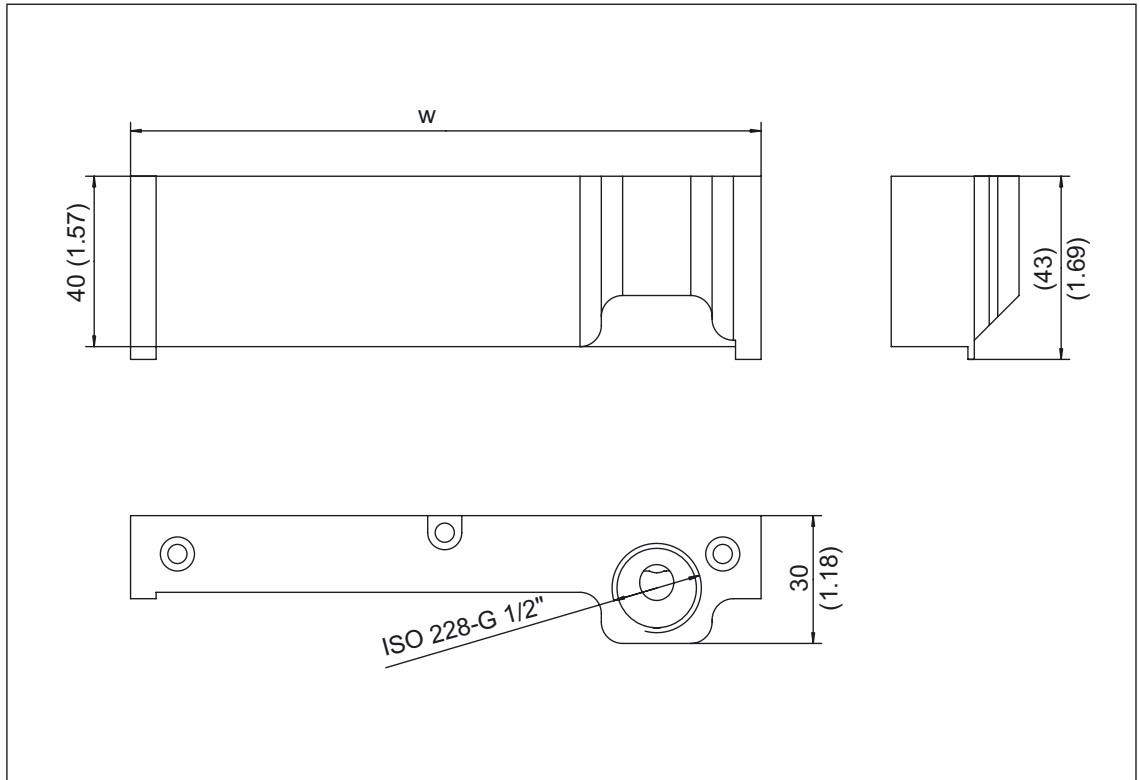

Figure 8-1 Dimension drawing of connection adapter

Table 8-1 Dimensions

Width of the power section [mm] (inches)	w [mm] (inches) of associated connection adapter
50 (1.97)	48.5 (1.91)
100 (3.94)	98.5 (3.88)
150 (5.91)	148 (5.83)
200 (7.87)	198 (7.80)
300 (11.81)	298 (11.73)

Space requirements for connection adapter

The connection adapter requires approx. 100 mm (3.94 inches) above and below the component. This does not, however, include the bending radius for the water hose, which means that extra space must be provided for the water supply lines.

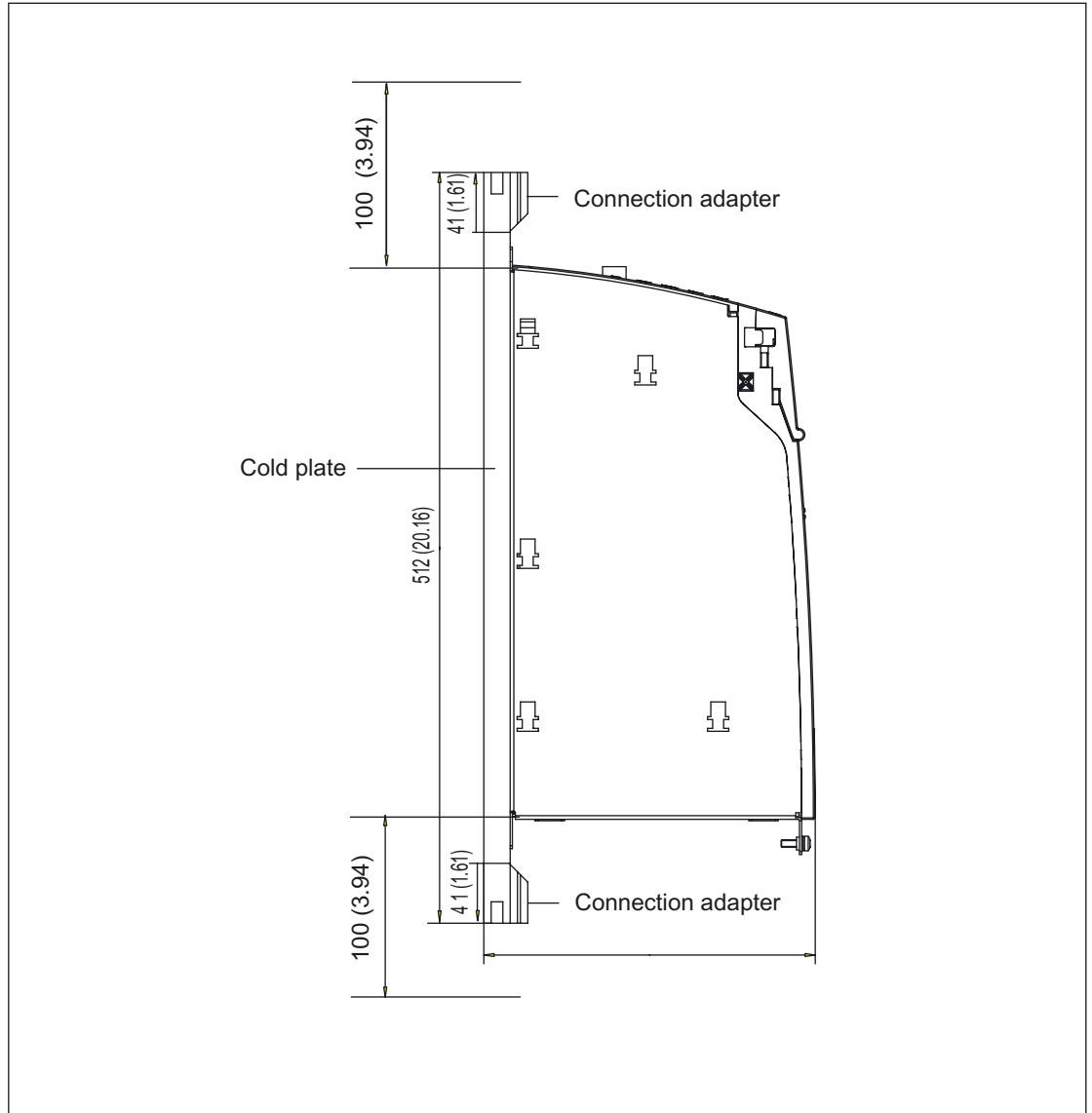

Figure 8-2 Space requirements for connection adapter

8.4 Installation

The connectors must be secured on site.
The hose connections must be made of stainless steel. The water connection can be up to 1/2".

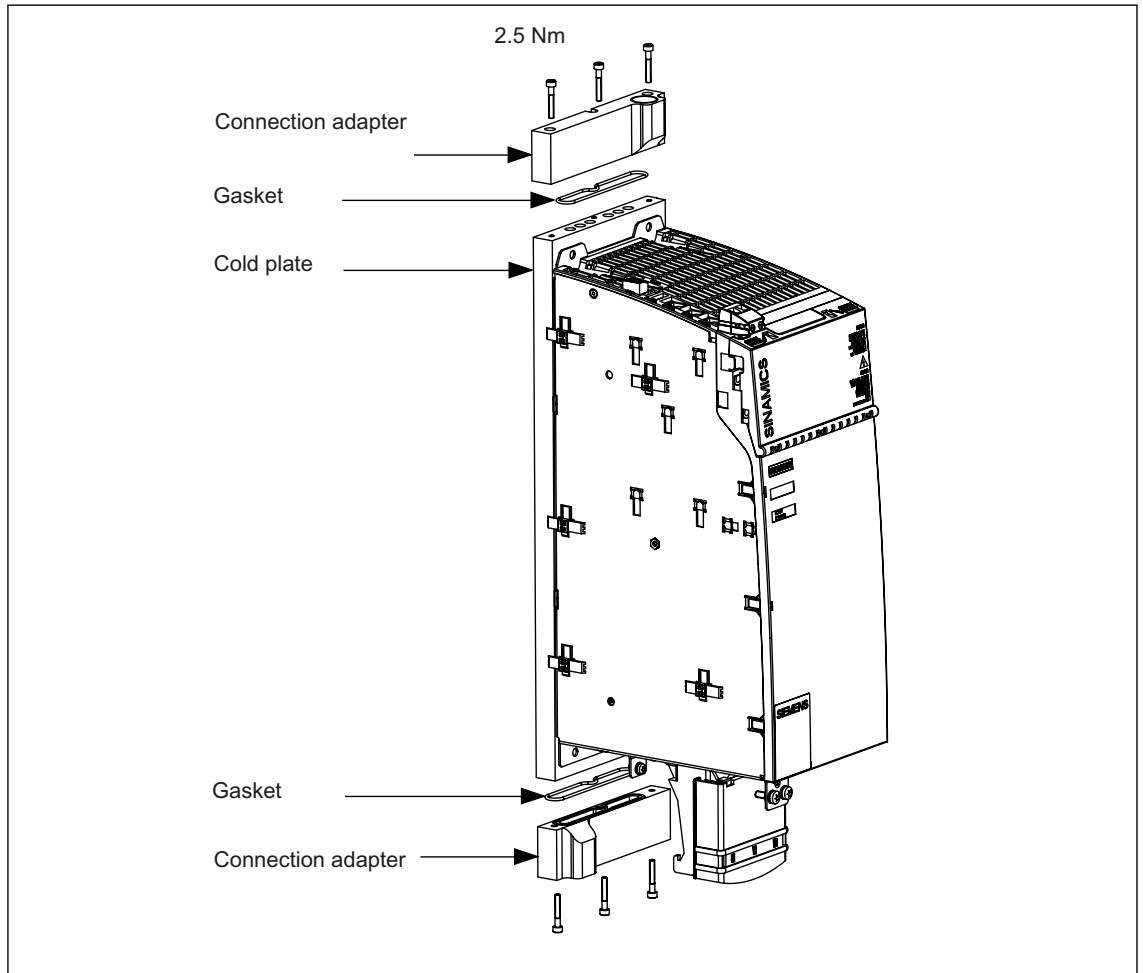

Figure 8-3 Connection method

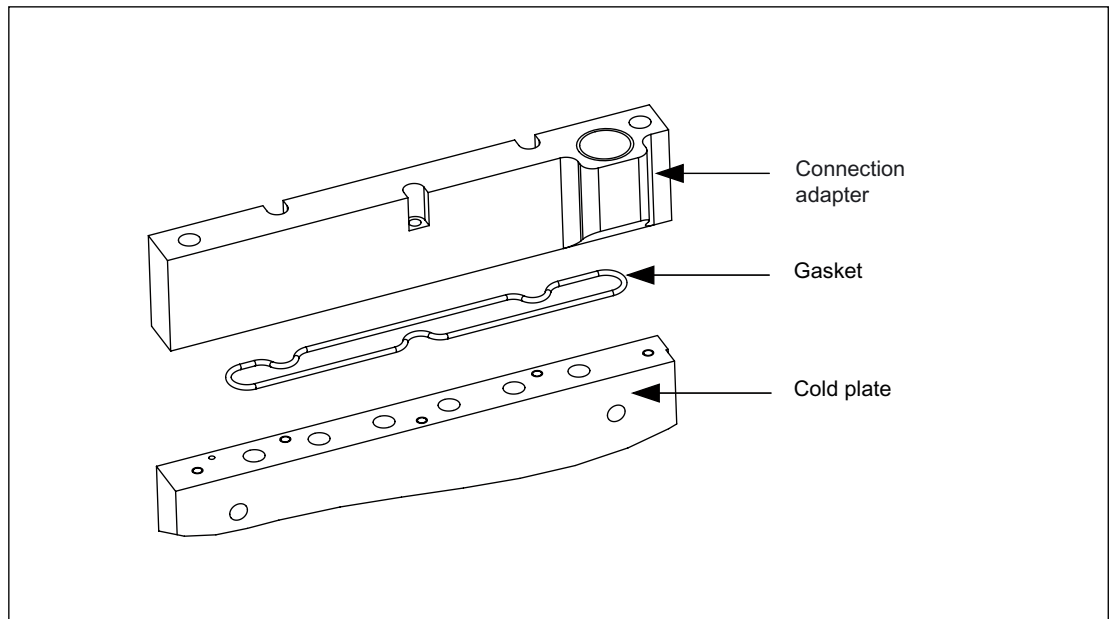

Figure 8-4 Example: connection adapter with seal

Power section with installed connection adapter

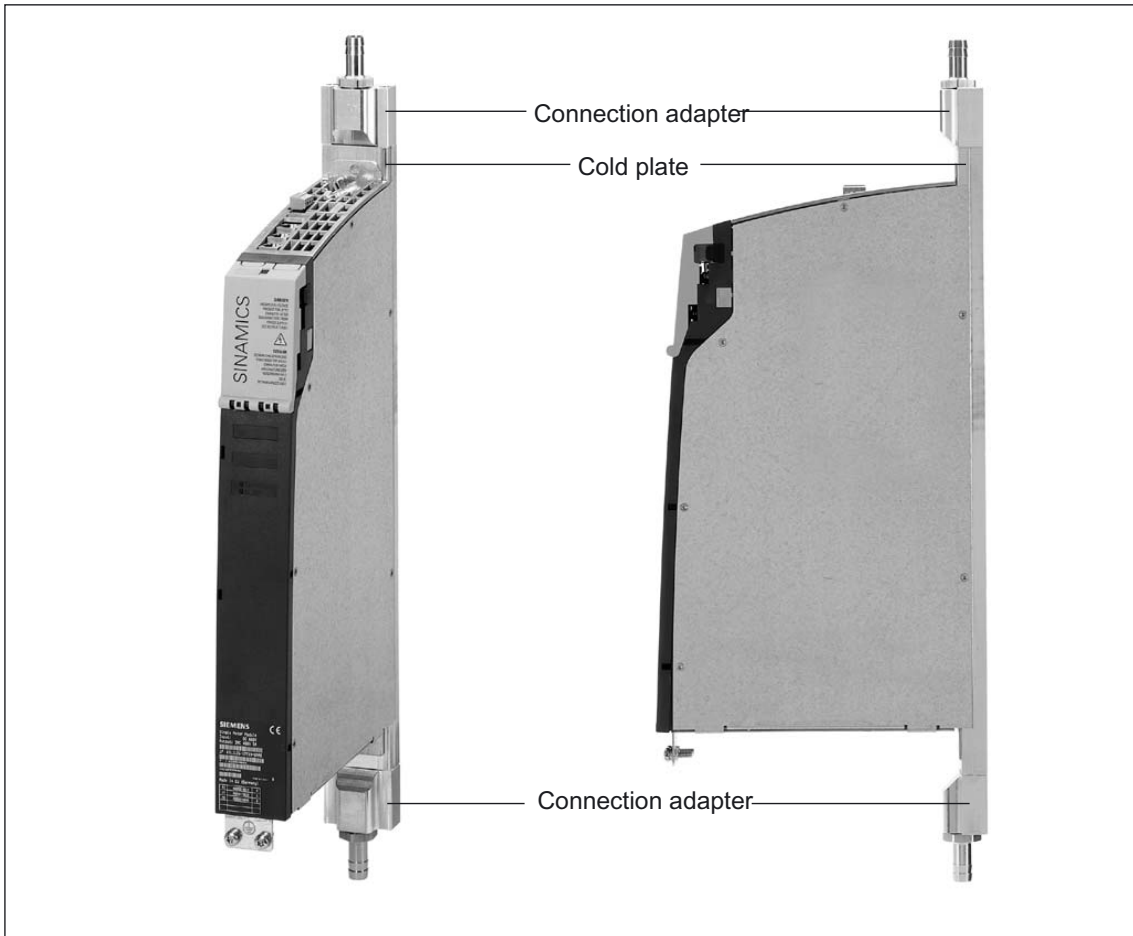

Figure 8-5 Example: 50 mm module with installed connection adapter

Internal Liquid Cooling

9.1 Cooling system requirements

Open cooling systems must never be used. Only closed cooling systems - preferably with a mechanism for monitoring the quality of the cooling water - must be installed.

The electrochemical processes that take place in a cooling system must be minimized by choosing the right materials. For this reason, mixed installations (i.e. a combination of different materials, such as copper, brass, iron, or halogenated plastic (PVC hoses and seals)) should not be used.

The fittings and connections required in the cooling system must be made of stainless steel (V2A or V4A steel; NIROSTA austenite).

The following materials can be used for the cooling system piping:

- Pipes and corrugated piping made of stainless steel (V2A or V4A steel; NIROSTA austenite)
- Hoses made of EPDM/EPDM with an electrical conductivity >109 ohm (e.g. Semperflex FKD; Semperit; <http://www.semperit.at>)
- DEMITEL® hoses made of PE/EPDM (Telle; <http://www.telle.de>)

Note

When non-conductive hoses are used, particular attention must be paid to the equipotential bonding of all the components. See Corrosion Inhibitor Additive (Inhibiting).

Notice

The sealing materials must be free of chloride, graphite, and carbon particulate (Viton® or EPDM).

Note

Once installed, the cooling system must be checked to ensure that it is properly sealed.

9.2 Cooling water requirements

Properties of the cooling medium

Water or a water/anti-freeze mixture that meets the relevant requirements can be used as a cooling medium. The cooling medium must be chemically neutral, clean, and not contain any solids.

The cooling water must fulfill the following requirements over the long term:

- Chemically neutral, clean, and free of solids
- Max. inlet temperature: 40 °C
- Max. outlet temperature: 50 °C
- Operating pressure: 1 bar to 6 bar
- Max. size of any conveyed particles: 0.1 mm
- pH value: 6.0 to 8.0
- Chlorides < 40 ppm
- Sulfates < 50 ppm
- Loose materials < 340 ppm
- Total hardness < 170 ppm
- Conductivity < 500 µs/cm

Note

Normal tap water does not generally fulfill these requirements, although it can be mixed with de-ionized water. Losses must always be replenished with de-ionized water.

The operating pressure must not exceed 6 bar.

Notice

The heat sink is made of non-seawater-proof material, which means that it must not be cooled directly with seawater.

Notice

Condensation must not be allowed to form on the SINAMICS S120 equipment as a result of supercooling. The temperature of the cooling water may have to be regulated.

A particle filter (particle size < 100 µm) must be installed in the cooling water circuit.

If there is a risk of frost, preventive measures must be taken during operation, storage, and transportation (e.g. emptying and blowing out with air, additional heating).

The cooling water should be checked 3 months after the cooling circuit is filled for the first time and, subsequently, once a year. If the cooling water becomes cloudy, is colored, or becomes contaminated by mould spores, the cooling circuit must be cleaned and refilled.

An inspection glass should be provided in the cooling circuit to make it easier to check the cooling water.

9.3 Anti-Freeze Additive

Antifrogen N (Clariant;) is recommended as an antifreeze. The proportion of anti-freeze must be between 20% and 30%. This ensures frost protection in temperatures of at least -10°C.

Notice

If the proportion of anti-freeze is greater than 30%, this can inhibit the transfer of heat and prevent the equipment from functioning correctly.

Note

You must always bear in mind that the kinematic viscosity of the cooling water changes when anti-freeze is added, which means that the pump power must be adjusted accordingly.

Notice

Cooling water mixtures with Antifrogen N are highly conductive. In the event of leakage, the insulating systems must be cleaned.

Notice

When EPDM hoses are used, oily corrosion inhibitor additives must not be used because additives can corrode and destroy EPDM.

9.4 Corrosion Inhibitor Additive (Inhibiting)

Nalco 00GE056 (ONDEO Nalco; <http://www.ondeonalco.com>) is recommended as a corrosion inhibitor. The concentration of corrosion inhibitor in the cooling water must be at least 2500 ppm (250 ml/100 liter KW).
The water quality must be in accordance with Chapter 9.3 or de-ionized water.

Notice

Corrosion inhibitor does not need to be added if the anti-freeze Antifrogen N is used in the right concentration (see Anti-Freeze Additive).

9.5 Biocide Additive (If Required)

- Adding Nalco N 77352 (ONDEO Nalco; <http://www.ondeonalco.com>) intermittently is recommended twice a month.
Required amount: 5 – 15 mg / 100 liter of cooling water. This product does not impair the effectiveness of the corrosion inhibitor with Nalco 00GE056.
- When anti-freeze Antifrogen N is used, the biocide should be sufficiently effective as of a concentration of 20%.

9.6 Equipotential Bonding

Equipotential bonding between the components in the cooling system is required (SINAMICS S120, heat exchanger, piping, pump, etc.). This must be effected using a copper bar or stranded copper with the appropriate conductor cross-sections to prevent the electrochemical processes.

All cabinets must be bolted together in such a way as to ensure good conductivity (e.g. cabinet beams directly connected to ensure conductivity) to prevent potential differences and, in turn, avoid the risk of electrochemical corrosion. For this reason, a PE bar must also be installed in all the cabinets, including the re-cooling system.

9.7 Water-to-Water Heat Exchanger

If a cooling circuit that does not exceed 35 °C but does not fulfill the cooling water requirements is already installed in the system, the two cooling circuits can be linked via a water-to-water heat exchanger.

The coolers for the frequency converters are attached via a distributor in such a way as to ensure the required flow without exceeding the required pressure. Conditions, such as height differences and distances, must be taken into account here.

For devices without frost protection, we recommend you use VARIDOS TOP from Schilling Chemie. VARIDOS TOP is an organic corrosion inhibitor that has been specially developed for half-open and closed cooling systems. It prevents corrosion by creating an organic protective film on the surface of the metal.

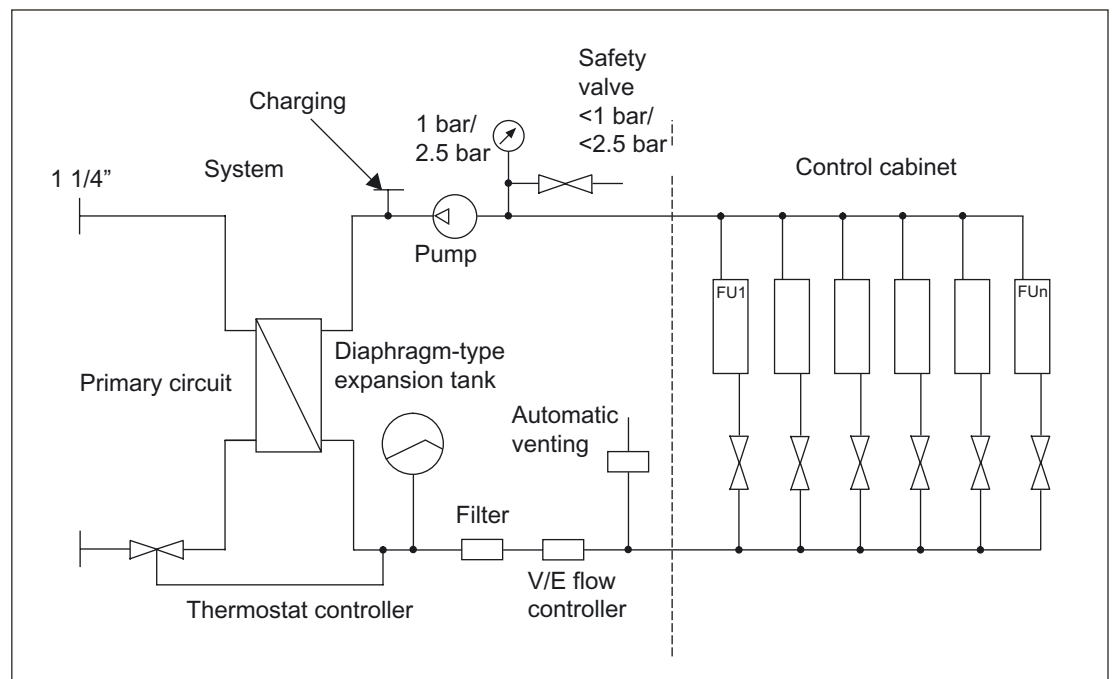

Figure 9-1 Water-to-water heat exchanger

9.8 Air-to-Water Heat Exchanger

If a process water network is not installed but it is nonetheless best to use water-cooled frequency converters, an air-to-water cooling system can be used. The temperature of the ambient air must not be excessively high (e.g. > 35 °C) (in accordance with the technical specifications for the air-to-water heat exchanger).

During setup, you must ensure that a primary air cooling circuit and not a process water circuit is installed.

Measures to prevent supercooling must only be taken on the secondary side by means of temperature closed-loop control, a thermostat, or a solenoid valve.

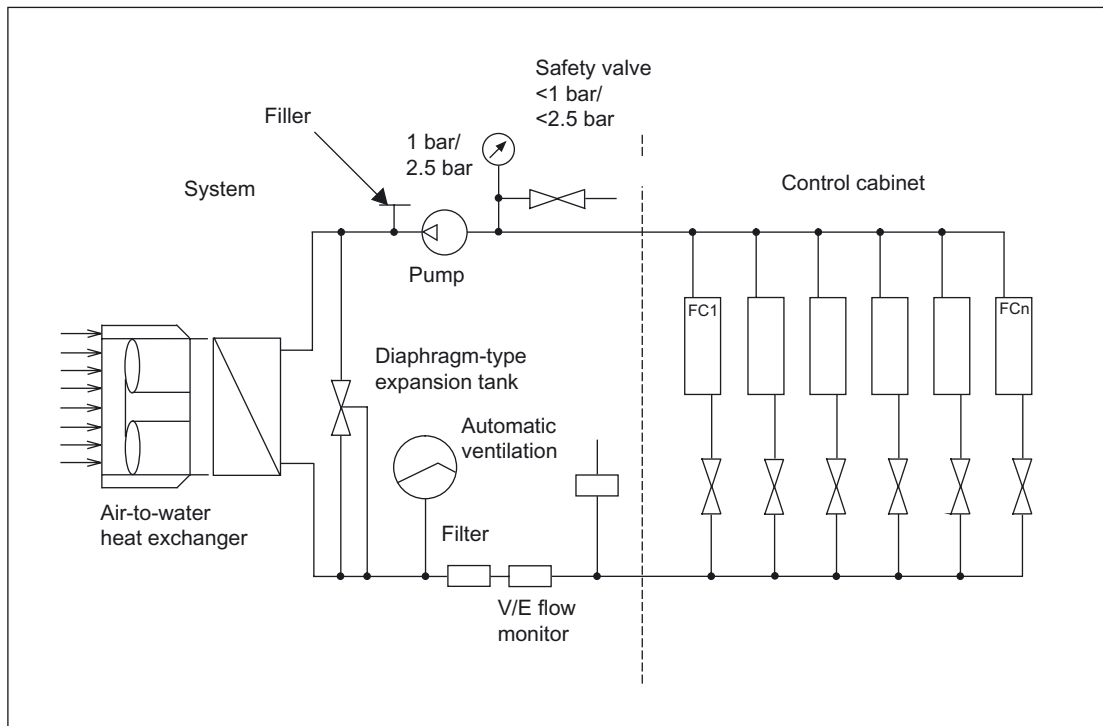

Figure 9-2 Air-to-water heat exchanger

9.9 Active Cooling Unit

If a process water network has not been installed and the ambient air is $> 35\text{ }^{\circ}\text{C}$ ($35\text{ }^{\circ}\text{C} < \tau < 40\text{ }^{\circ}\text{C}$), an active cooling unit can be used. This works in the same way as a refrigerator, whereby higher discharge air temperatures can be generated.

The following diagram shows the converter-side configuration of the cooling circuit.

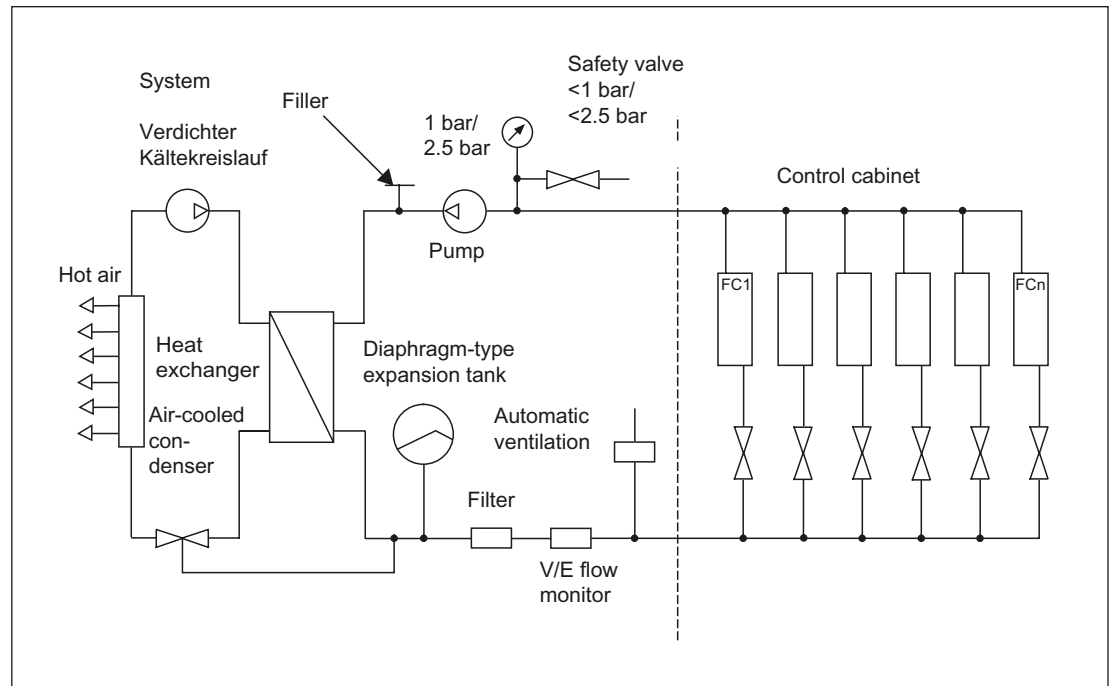

Figure 9-3 Active cooling unit

DC link components

10.1 Braking Module

10.1.1 Description

A braking module (and an external braking resistor) is required to bring drives to a controlled stop in the event of a line failure (e.g. emergency retraction or EMERGENCY OFF category 1) or to limit the DC link voltage during short-time regeneration if, for example, the regenerative capability of the line module has been deactivated or has not been dimensioned sufficiently.

The braking module contains the required power electronics and the associated control. When the braking module is operated, the energy supplied back is dissipated via an external braking resistor. The resistor is installed outside the cabinet.

The braking module can also be used with a braking resistor for fast discharging of the DC link. The DC link is discharged in a controlled manner via the braking resistor once the rectifier unit has been switched off and the line-up has been disconnected from the power supply (e.g. main circuit-breaker, line contactor). The function can be activated via a digital input on the braking module.

To operate the braking modules, a minimum capacitance is required in the DC link.

Depending on the braking resistor used, this is:

braking resistor 25 kW, DC link capacitance 220 μF ;

braking resistor 100 kW, DC link capacitance 330 μF .

The capacitance of the braking module (110 μF) is included in the total capacitance.

When the braking modules are connected in parallel, the above-mentioned minimum capacitance must be available for each braking module.

Note

Only the modules that are connected to each other via the DC link busbar can be included in the total capacitance.

The cable between the braking module and the braking resistor is limited to 10 m.

10.1.2 Safety information



Warning

After disconnecting all the supply voltages, a hazardous voltage will be present in all components for another 5 minutes. The protective cover must not be opened until this time has elapsed.

When opening the protective cover for the DC link, you must activate the release. A suitable tool (e.g. screwdriver) must be used for this purpose.

The components must only be operated when the protective cover of the DC link is closed. Damaged components must not be used, otherwise this could result in secondary damage or accidents.



Caution

The DC link discharge voltage hazard warning must be affixed to the modules in the local language.

A set of labels in 12 languages is available using order number: 6SL3166-3AB00-0AAx.

With a connected braking resistor, the Braking Module is ground-fault proof.

Notice

The 80 mm clearances above and below the components must be observed.

Caution

The connection to the braking resistors must be made using a shielded cable.

The tightening torque of the DC link busbar screws (1.8 Nm, tolerance: +30%) must be checked before startup. After transportation, the screws must be tightened.

Note

If braking resistors that are not listed in catalog D21.2 are used, they can be destroyed.

Caution

The left and right ends of the DC link busbar of a drive line-up must be fitted with peripheral covers (order no.: 6SL3162-5AA00-0AA0).

10.1.3 Interface description

10.1.3.1 Overview

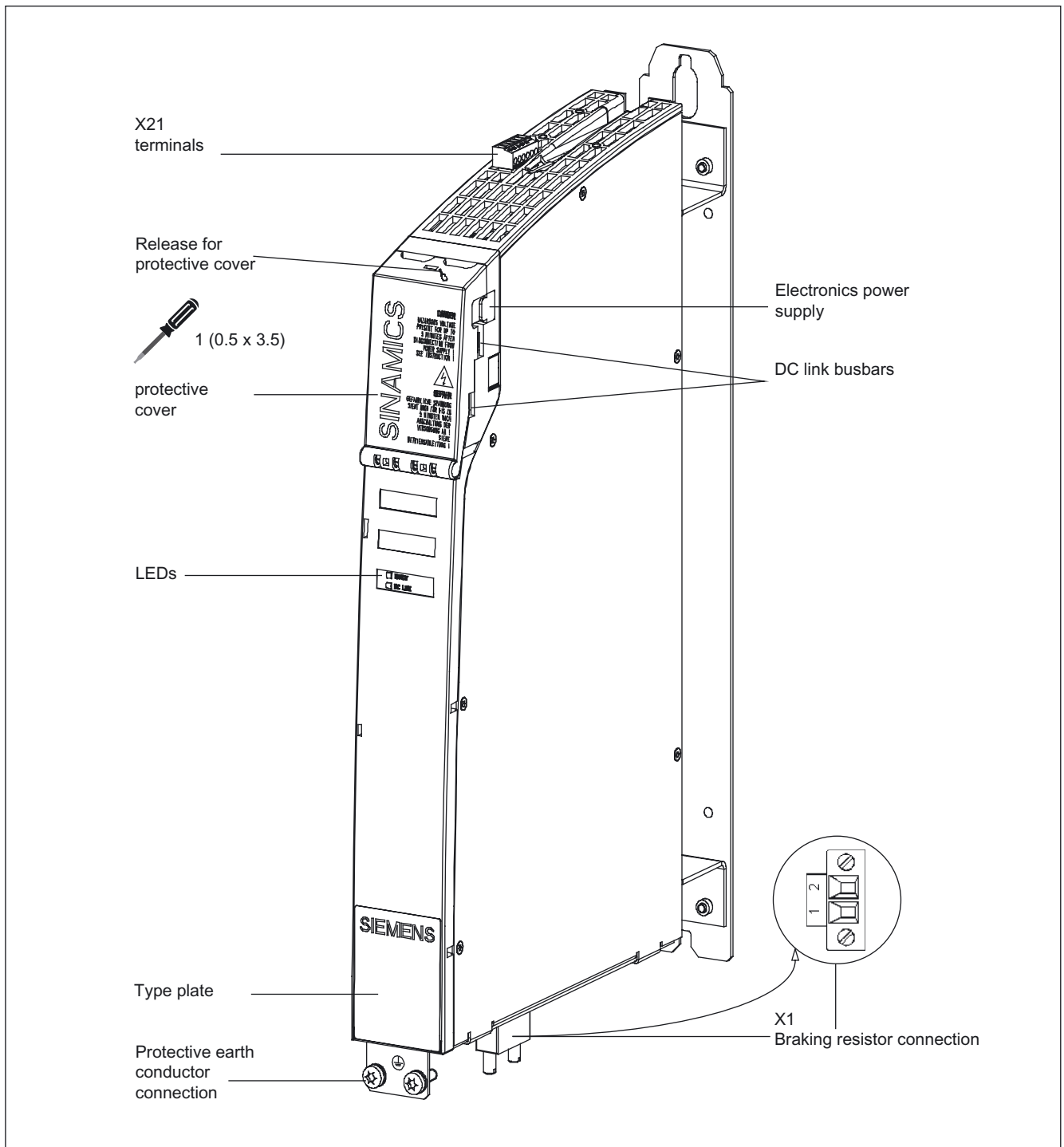

Figure 10-1 Interface description of braking module

10.1.3.2 Connection example

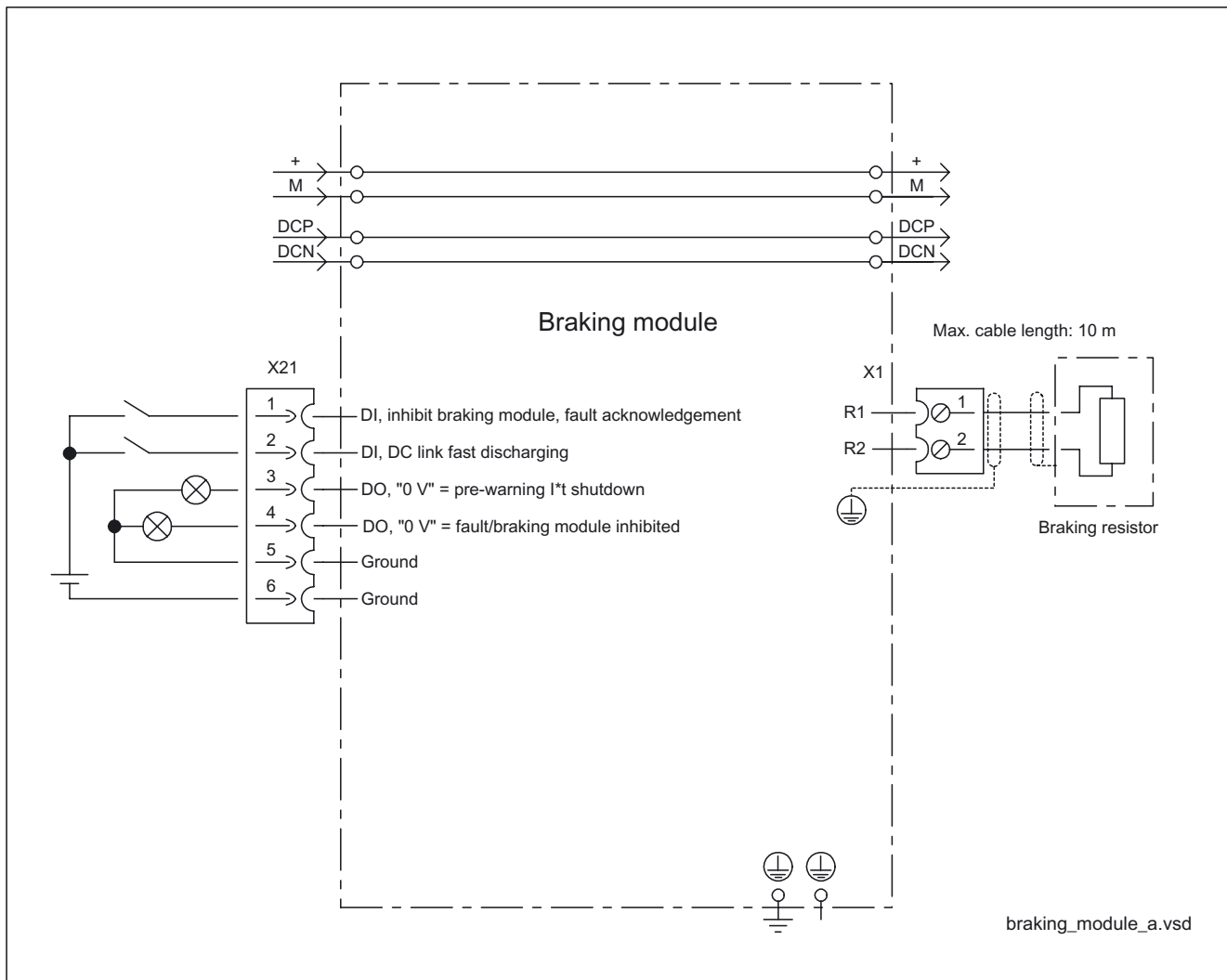
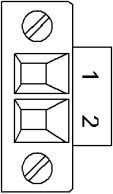

Figure 10-2 Connection example of braking module

10.1.3.3 Braking resistor connection X1

Table 10-1 Terminal block X1

	Terminal	Name	Technical specifications
	1	Braking resistor connection R1	Continued-short-circuit-proof
	2	Braking resistor connection R2	
Max. connectable cross-section: 4 mm ² Type: Screw terminal 4 (see Connection Methods)			

10.1.3.4 X21 digital inputs/outputs

Table 10-2 Terminal block X21

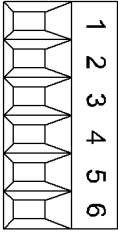
	Terminal	Name ¹⁾	Technical specifications
	1	DI low: enable braking module DI high: braking module inhibited Edge change high -> low: fault acknowledgement	Voltage: -3 V to 30 V Typical current consumption: 10 mA at 24 V DC Level (incl. ripple) High level: 15 V to 30 V Low level: -3 V to 5 V
	2	DI low: braking resistor not activated manually DI high: braking resistor activated manually (fast discharge) Safety functions remain active, I*t protection remains active If X21.1 and 2 are activated simultaneously, the braking module inhibit has priority.	
	3	DO high: no pre-warning for I*t shutdown DO low: pre-warning for I*t shutdown (80% of max. ON time reached)	Max. load current per output: 100 mA Continued-short-circuit-proof Voltage: 24 V DC
	4	DO high: ready for operation, no fault DO low: fault; braking module inhibited	
	5	Ground	
	6		
Max. connectable cross-section 1.5 mm ² Type: Screw terminal 1 (see Connection Methods)			

1) DI: digital input; DO: digital output; M: electronic ground

Note

Applying a high signal to terminal X21.1 inhibits the braking module. On a falling edge, pending error signals are acknowledged.

The pre-warning for I*t monitoring is output as a high level on reaching 80% of the maximum braking resistor ON time.

Only braking resistors approved by Siemens for this component are identified automatically.

10.1.3.5 Meaning of the LEDs on the braking module

Table 10-3 Meaning of the LEDs on the braking module

LED	Color	State	Description
READY	-	OFF	Electronics power supply outside permissible tolerance range.
	Green	Continuous	The component is ready for operation.
	Red	Continuous	<ul style="list-style-type: none"> • Braking module inhibited via DI X21.1 • Braking module shutdown Possible reasons: <ul style="list-style-type: none"> - Overcurrent - Overtemperature heat sink - Braking resistor overload (I*t shutdown)
DC LINK	-	OFF	Braking resistor switched off (DC link discharge not active)
	Green	Flashing	Braking resistor switched on (DC link discharge active)

Note

To protect the braking resistor, the current fault cannot be acknowledged until after a waiting period of approx. 3 min after an I*t shutdown of the braking module.

10.1.4 Dimension drawing

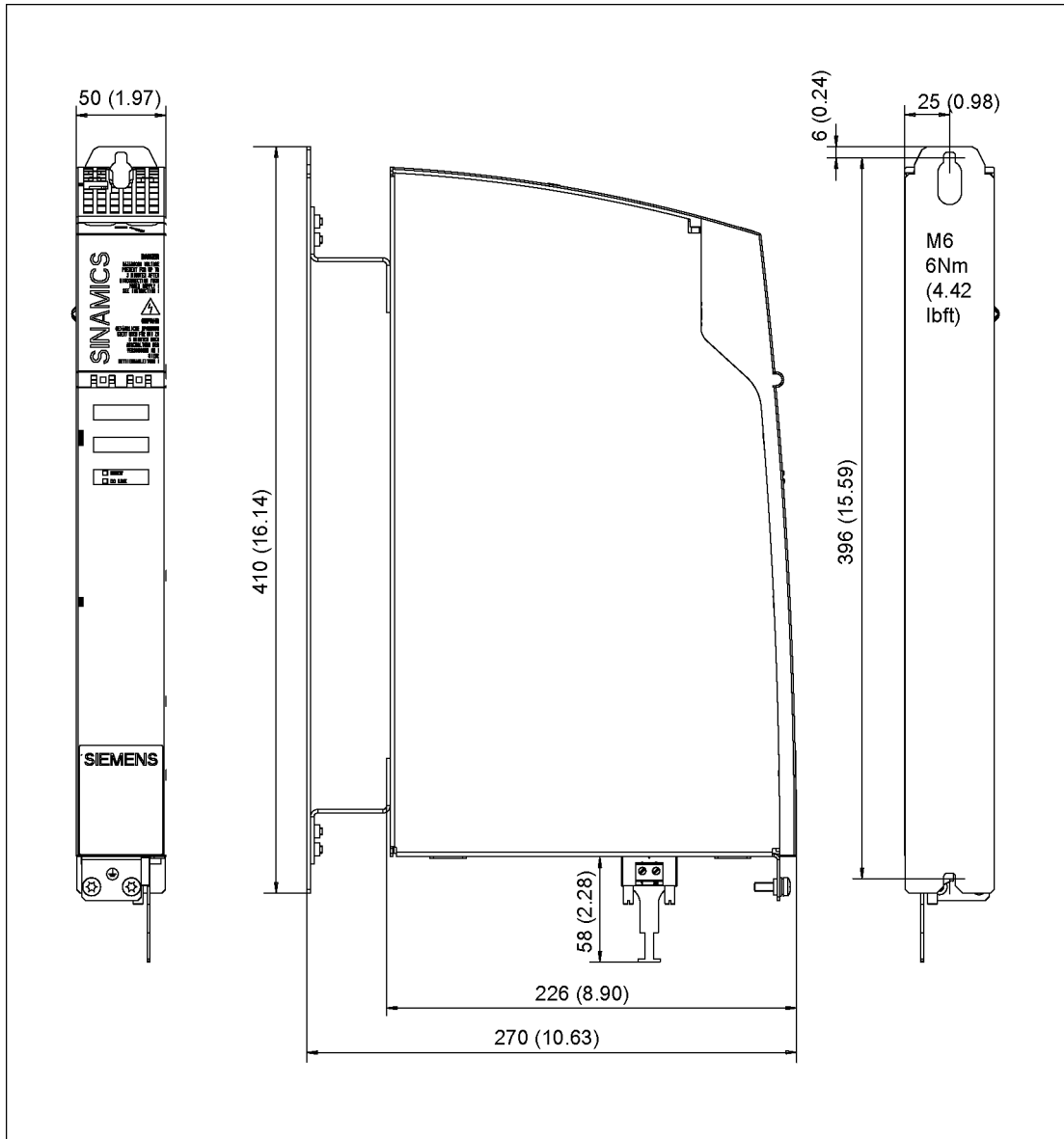

Figure 10-3 Dimension drawing of the braking module

10.1.5 Installation

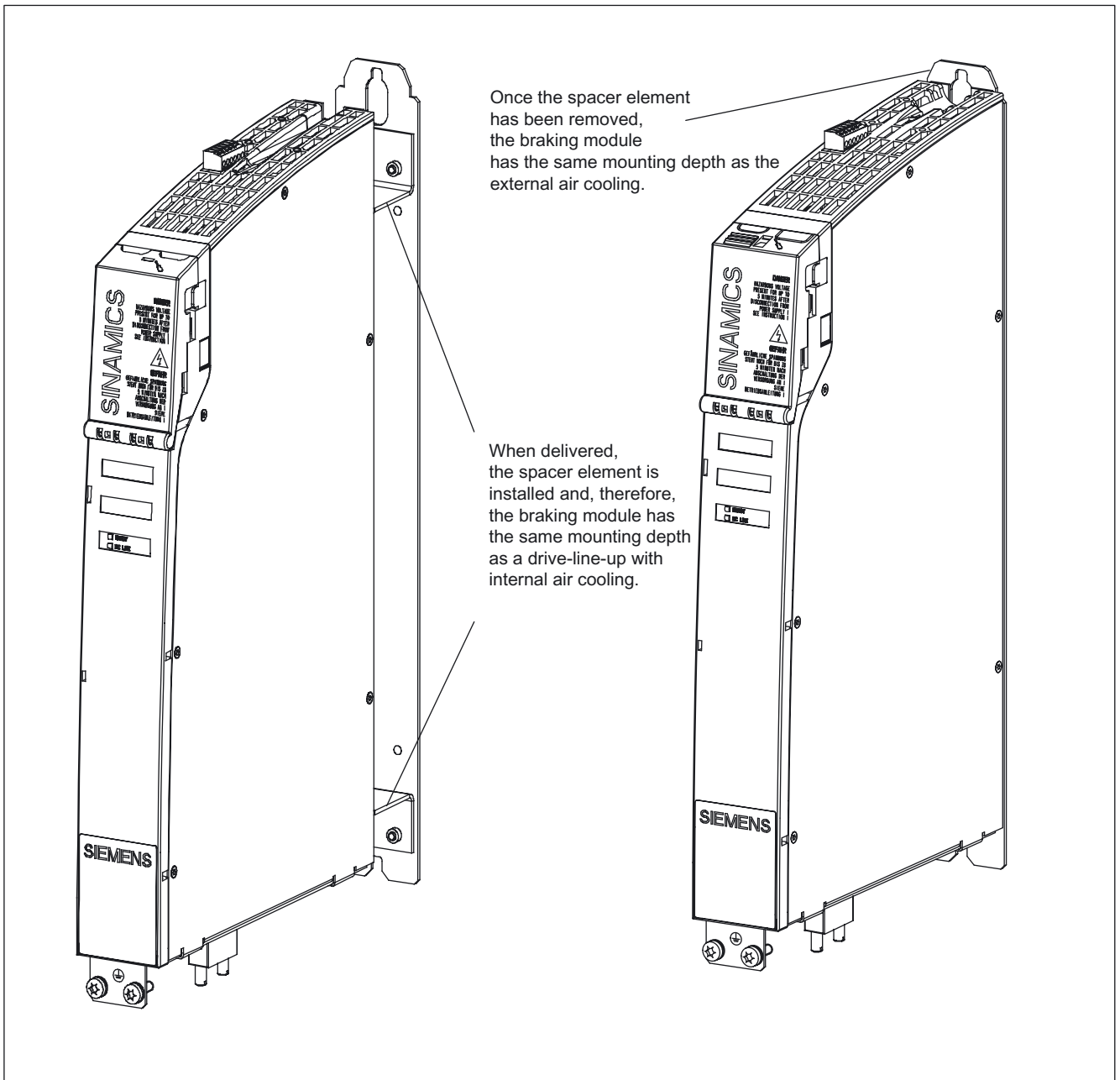

Figure 10-4 Methods of installing braking modules with/without spacer elements

10.1.6 Technical specifications

Table 10-4 Technical Specifications

Braking module booksize		
Voltages		
Supply:		
DC link voltage	V _{DC}	510 - 750
ON threshold	V	770
Electronics power supply	V _{DC}	24 (20.4 - 28.8)
Electronics current consumption (at 24 V DC)	A _{DC}	0.5
26 V DC busbar current carrying capacity	A _{DC}	100
26 V DC busbar current carrying capacity	A _{DC}	20
Max. braking power	kW	100
Continuous braking power	kW	1.5
Power loss ¹	W	20
• Cooling method		Natural convection
• Weight	kg	4.1

¹ For an overview, see the power loss tables in Cabinet Design.

10.2 Braking resistors

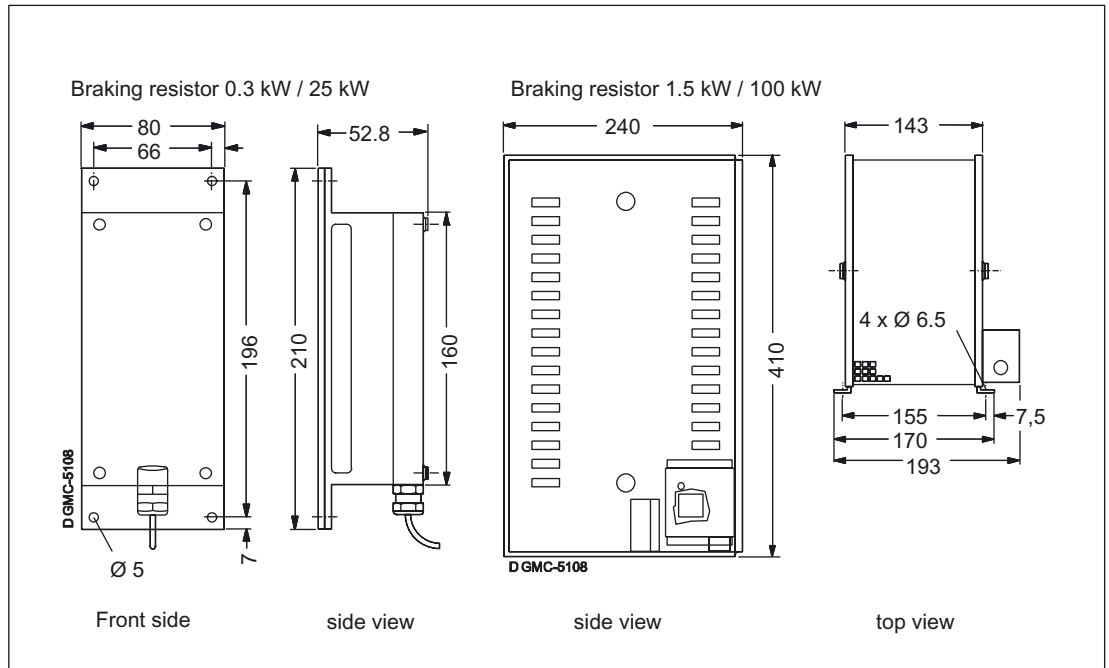

Figure 10-5 Dimension drawings of braking resistors



Caution

The surface temperature of the braking resistors may exceed 80 °C.

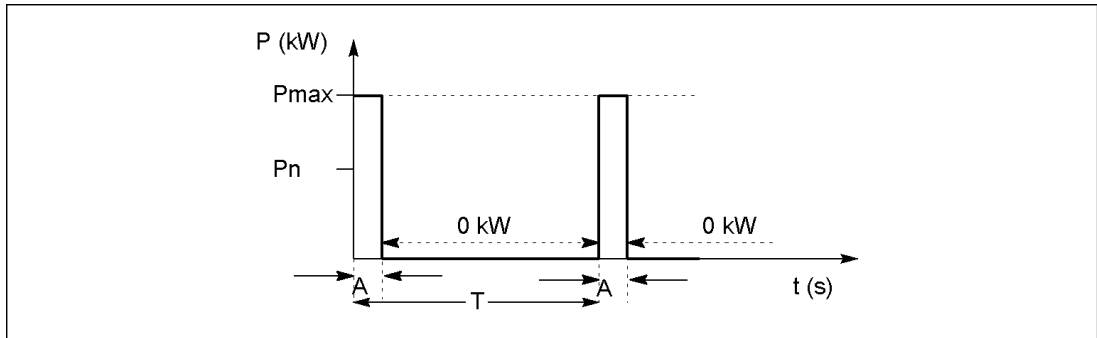

Figure 10-6 Duty cycle for braking resistors

T [s] period duration of braking duty cycle

A [s] load duration

P_n [W] continuous braking power of braking resistor

P_{max} [W] peak braking power of braking resistor

Table 10-5 Example of duty cycles

	Unit	R 25 kW		R 100 kW	
		Short duty cycle	Long duty cycle	Short duty cycle	Long duty cycle
A	s	0.1	0.4	1	2
T	s	11.5	210	68	460

Table 10-6 Technical Specifications

	Unit	Braking resistor 6SN1113-1AA00-0DA0	Braking resistor 6SL3100-1BE31-0AAx
P_{max}	kW	25	100
P_n	kW	0.3	1.5
Weight	kg	3.4	5.6
Degree of protection		IP54	IP20

Connection cables

A shielded connection cable (3 m long; 1.5 mm²) is supplied with braking resistor 6SN1113 1AA00-0DA0.

Braking resistor 6SL3100-1BE31-0AA0 is supplied without a connection cable (4 mm²).

The maximum cable length for both braking resistors is 10 m.

10.3 Capacitor Module

10.3.1 Description

Capacitor modules are used to increase the DC link capacitance to bridge momentary power losses.

Capacitor modules are connected to the DC link voltage via the integrated DC link busbars. Capacitor modules function autonomously.

Several capacitor modules can be operated in parallel.

10.3.2 Safety Information



Warning

After disconnecting all the supply voltages, a hazardous voltage will be present in all components for another 5 minutes. The protective cover must not be opened until this time has elapsed.

When opening the protective cover for the DC link, you must activate the release. A suitable tool (e.g. screwdriver) must be used for this purpose.

The components must only be operated when the protective cover of the DC link is closed. Damaged components must not be used, otherwise this could result in secondary damage or accidents.



Caution

The DC link discharge voltage hazard warning must be affixed to the modules in the local language.

A set of labels in 12 languages is available using order number: 6SL3166-3AB00-0AAx.

Notice

The 80 mm clearances above and below the components must be observed.

Notice

The capacitor module is precharged by the line module. The relevant charging limits of the line modules must be taken into account.

10.3.3 Interface description

10.3.3.1 Overview

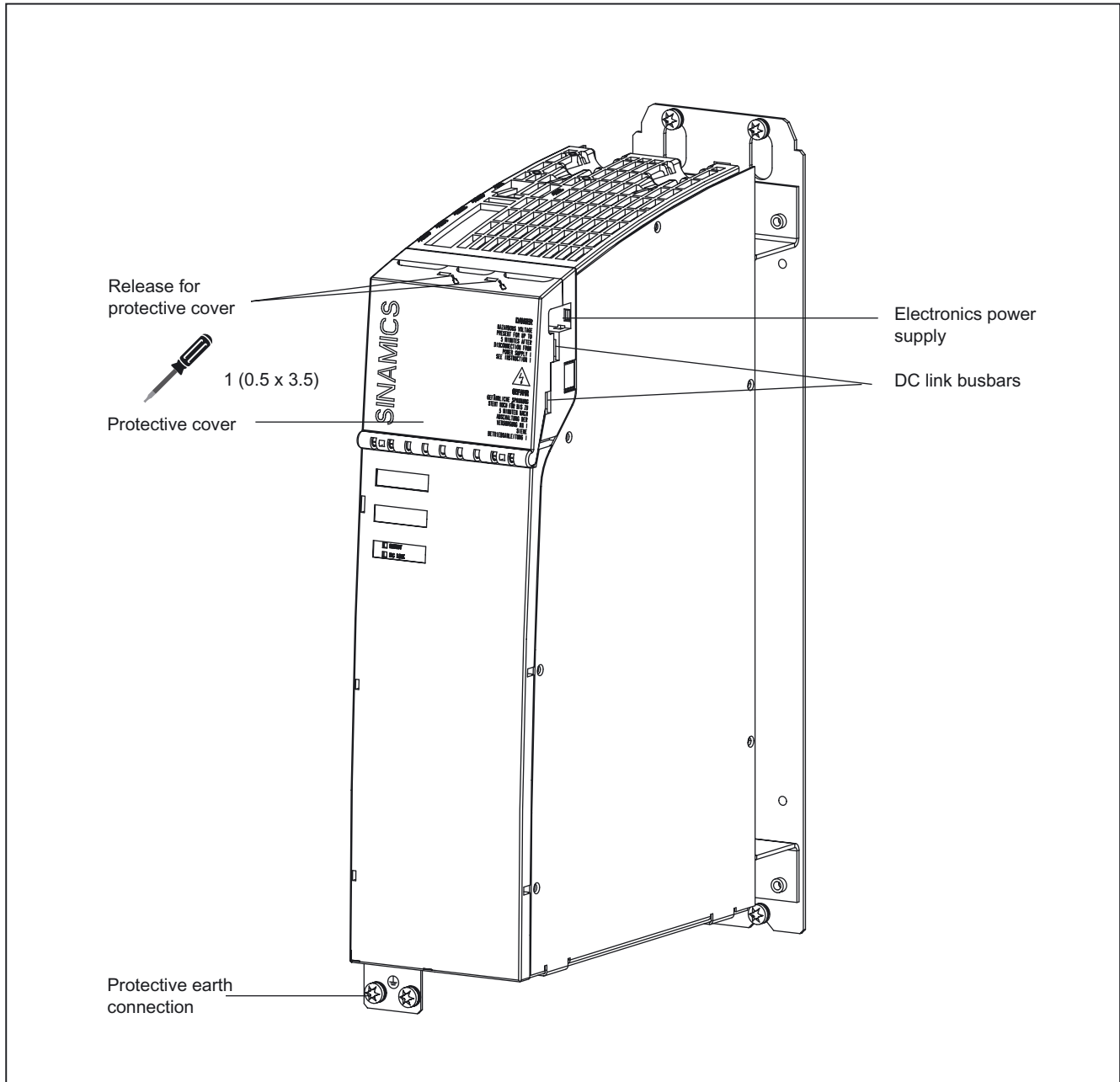

Figure 10-7 Interface description of the capacitor module

10.3.4 Dimension Drawing

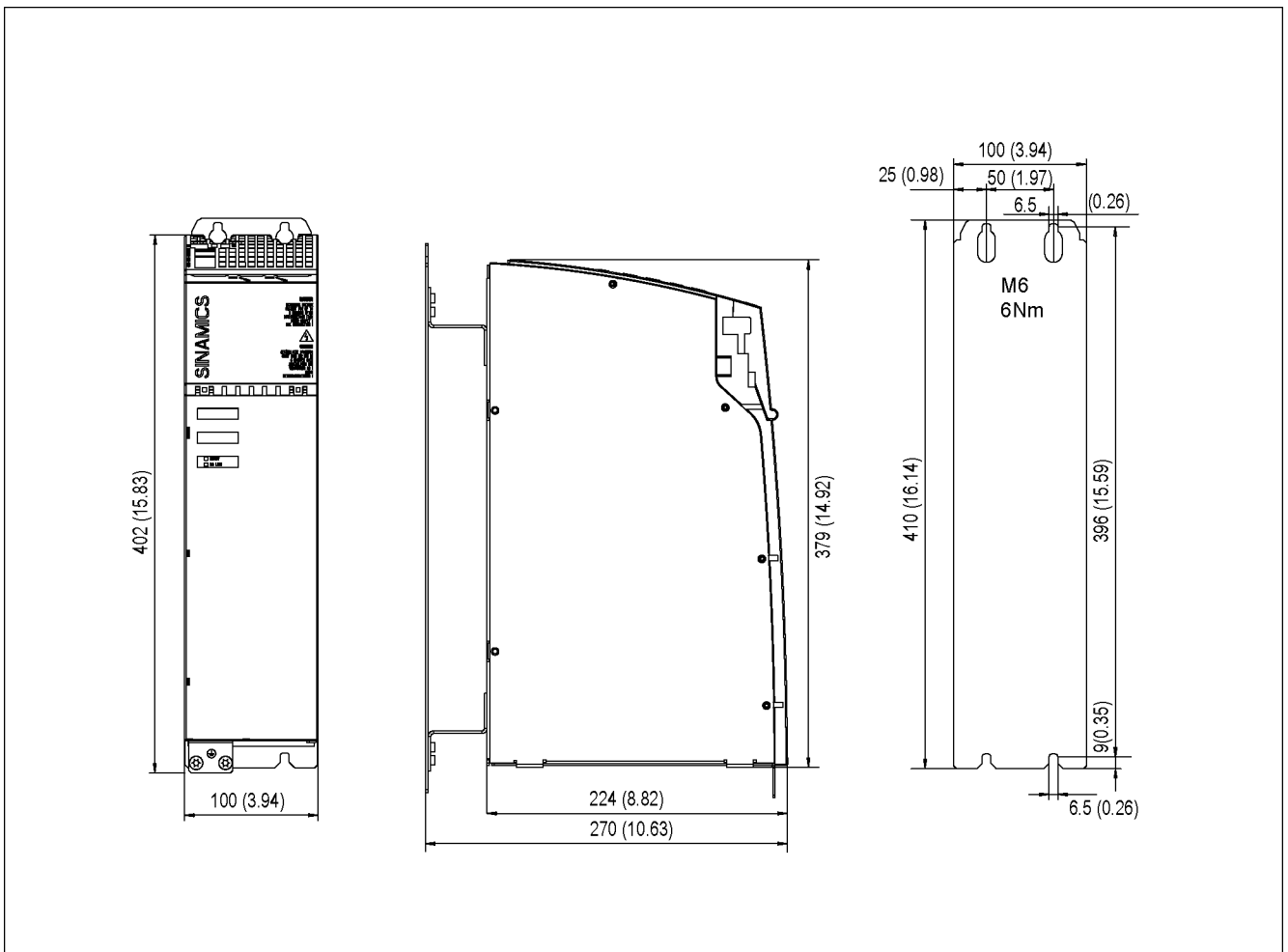

Figure 10-8 Dimension drawing of the capacitor module

10.3.5 Installation

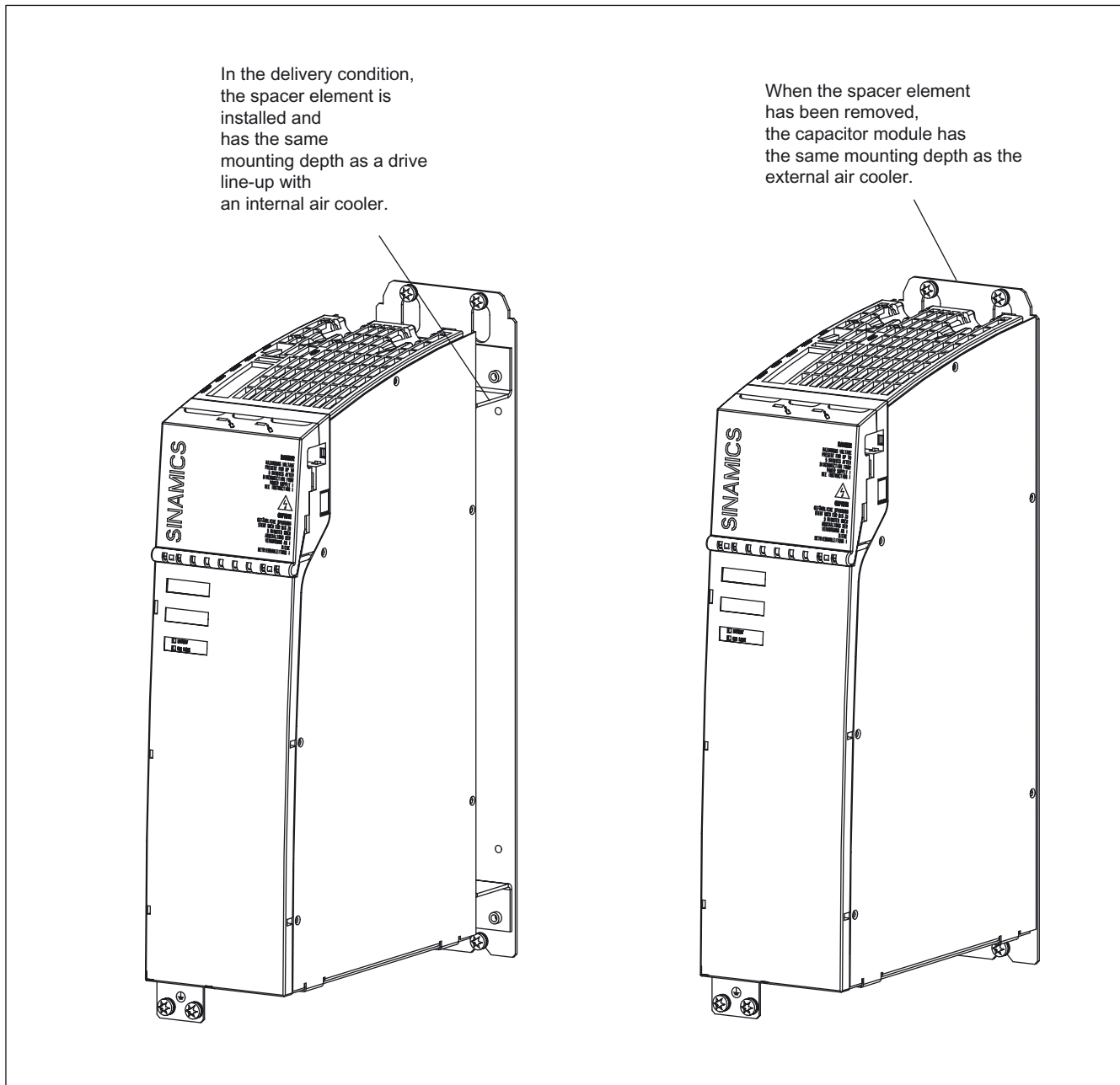

Figure 10-9 Installing a capacitor module with/without spacer elements

The capacitor module can be attached to the cabinet with or without spacer elements.

10.3.6 Technical Specifications

Table 10-7 Technical Specifications

Capacitor Module		
Electronics power supply	V _{DC}	24 (20.4 - 28.8)
DC link voltage	V _{DC}	510 - 750
Capacitance	μF	4000
24 V DC busbar current carrying capacity	A	20
DC link busbar current carrying capacity	A	100
Power loss ¹	W	25
Weight	kg	7.2

¹ For an overview, see the power loss tables in Cabinet Design.

10.4 Control Supply Module

10.4.1 Description

The Control Supply Module (CSM) provides a 24 V DC power supply via the power system or DC link. In this way, controlled emergency retraction movements can be made in the event of a power failure, for example, provided that the DC link voltage is available.

The supply voltage is a PELV (protective extra low voltage). The earth potential for the protective conductor system is connected in the Control Supply Module.

Input voltage range: 320-550 V_{AC}, 430-800 V_{DC} (300-430 V_{DC} for <1min).

Startup is only possible via the power system.

10.4.2 Safety Information



Danger

This component is equipped with two supply circuits. After disconnecting all the supply circuits, a hazardous voltage will be present in all components for another 5 minutes. The protective cover must not be opened until this time has elapsed.

When opening the protective cover for the DC link, you must activate the release. A suitable tool (e.g. screwdriver) must be used for this purpose.

The components must only be operated when the protective cover of the DC link is closed. Damaged components (e.g. with a defective lock on the protective cover) must not be operated further.

Failure to comply with these instructions can result in death or severe injury.

Caution

The DC link discharge time hazard warning must be affixed to the modules in the local language.

A set of labels in 12 languages is enclosed with the module.

Notice

The 80 mm clearances above and below the components must be observed.

Caution

The tightening torque of the DC link busbar screws (1.8 Nm, tolerance: +30%) must be checked before startup. After transportation, the screws must be tightened.

Caution

The left and right ends of the DC link busbar of a drive line-up must be fitted with peripheral covers (order no.: 6SL3162-5AA00-0AA0).

Caution

If used, the 24 V terminal adapter must be screwed into place. The following screw must be used: EJOT-PT screw K30 x 16. Tightening torque 0.5 Nm.

10.4.3 Interface description

10.4.3.1 Overview

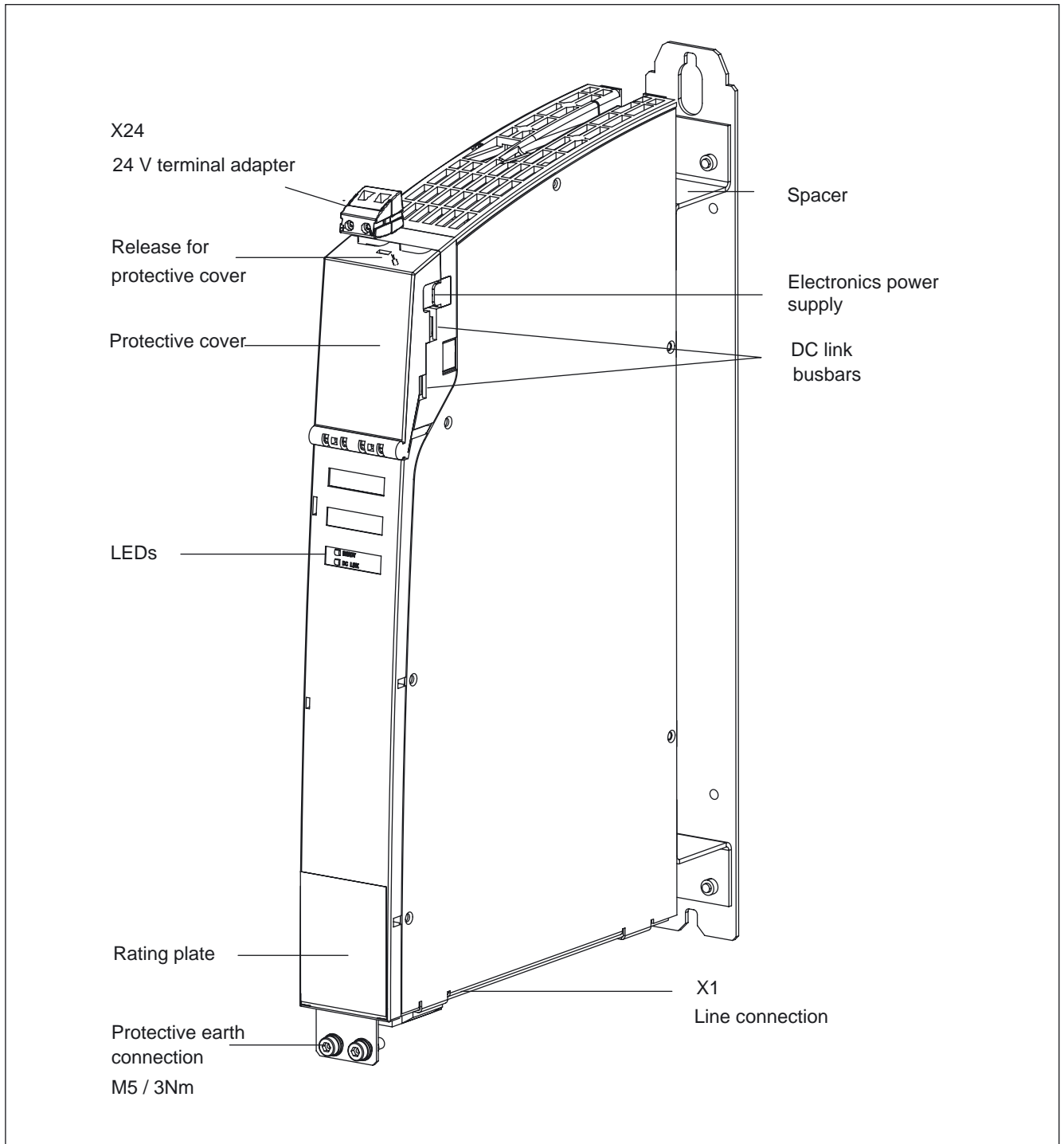

Figure 10-10 Interface description: control supply module

10.4.3.2 Connection example

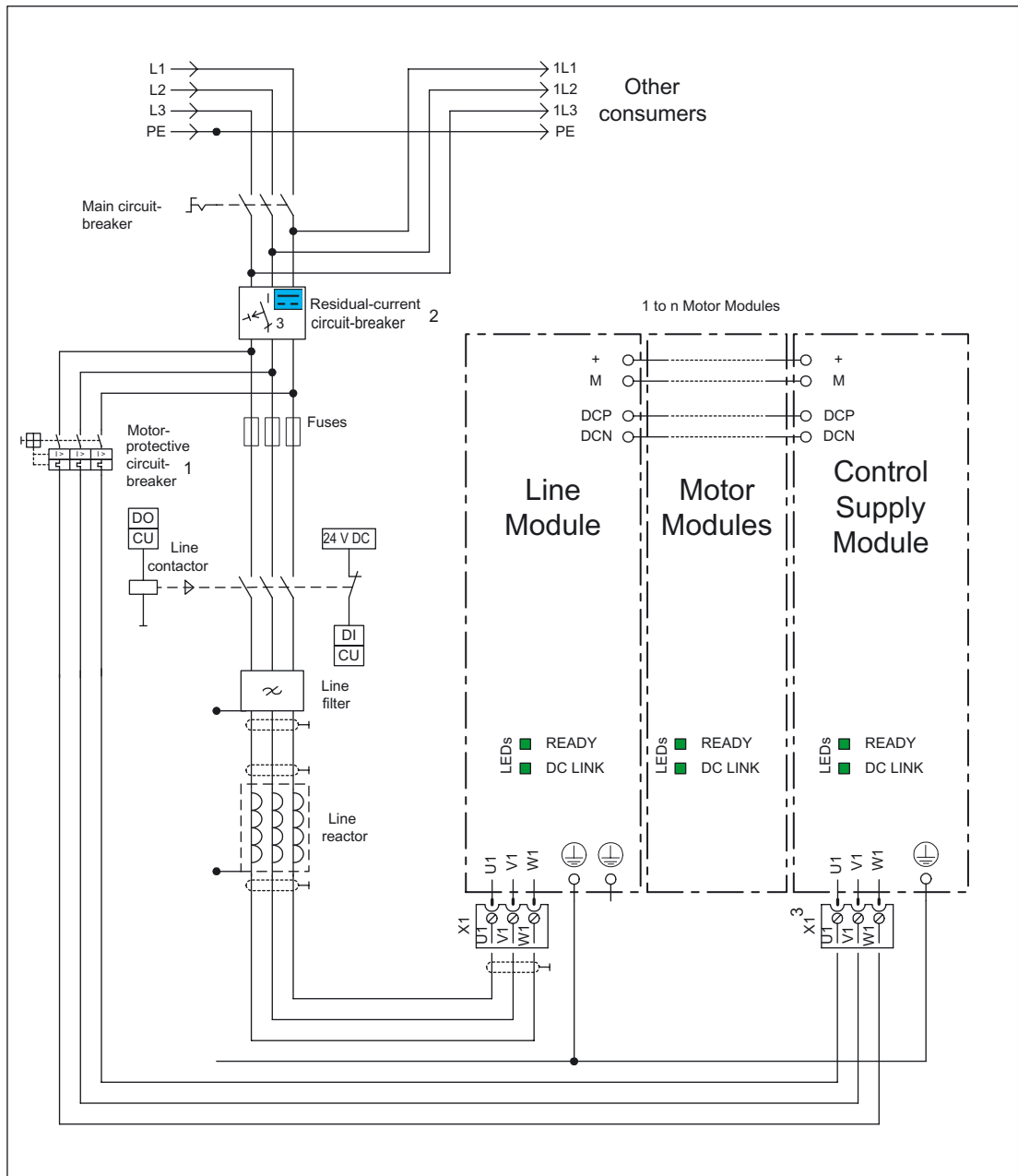

Figure 10-11 Connection example of Control Supply Module

- ¹ Permissible types:
 - a) SIRIUS motor circuit-breaker, 3RV 1021 1DA10, set to 3A
 - b) KTS-R-6-type branch circuit fuse (class RK1)
- ² Optional
- ³ The line connection must always exist

10.4.3.3 Meaning of the LEDs on the control supply module

Table 10-8 Control Supply Module - Description of the LEDs

LED	Color	State	Description
READY	-	OFF	Electronics power supply outside permissible tolerance range.
	Green	Continuous	Ready for operation. Output voltage within tolerance range.
DC LINK	-	OFF	DC input voltage < 290 V _{DC} , floating operation not possible
	Yellow	Continuous	DC input voltage in the range 370 < U _e < 820 V _{DC} Floating operation possible
	Red	Continuous	DC input voltage outside the tolerance range. DC input voltage 290 V < U _e < 370 V or U _e > 820 V _{DC}

10.4.4 Dimension Drawing

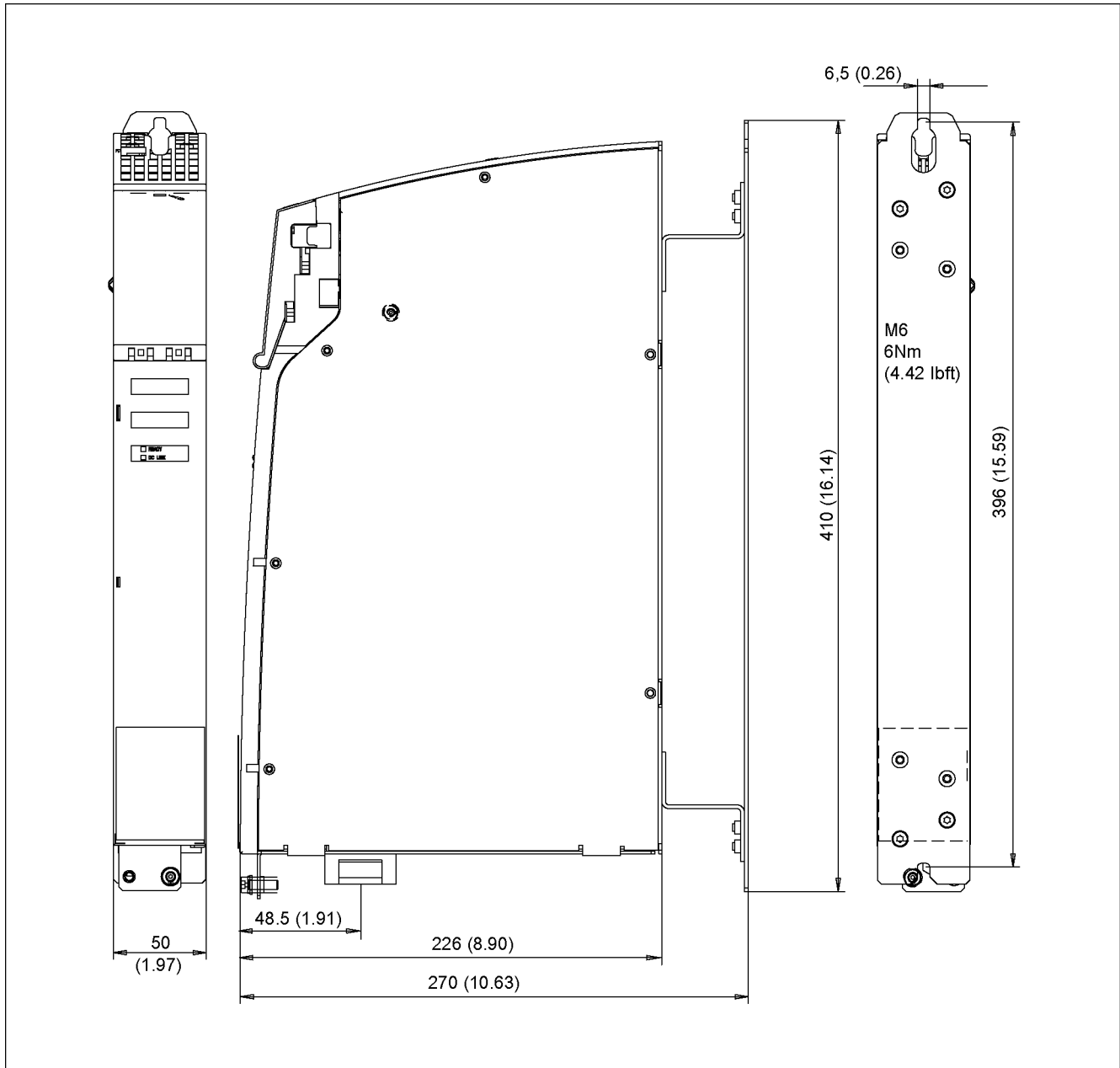

Figure 10-12 Dimension drawing of the control supply module

10.4.5 Technical Specifications

Table 10-9 Technical Specifications

Control Supply Module	Unit	Value
Input data		
Line voltage	V _{AC}	3AC 380 - 480 V _{AC} ± 15%
Line frequency	Hz	47 to 63
Connection currents		
Rated value (at U _{eRated})	A _{AC}	approx. 2
Starting current inrush	A _{AC}	Max. 80
Power loss ride-through (at 400 V _{AC})	ms	5
DC link voltage	V _{DC}	430 to 882 (300 to 430 < 1 min)
Supply current (at 600 V)	A _{DC}	1.1
Output data		
Output voltage	V _{DC}	26 +/- 2%
Output current	A _{DC}	20
Startup to short-circuit	A _{DC}	≤ 24
Short-circuit during operation	A _{DC}	Normally 23 (continuous)
Current carrying capacity of the 24 V DC busbars	A _{DC}	20
Efficiency U _{aRated} I _{aRated}	-	> 83%
Residual ripple (clock frequency approx. 50 kHz)	mV _{pp}	< 100
Cycle peaks (bandwidth 20 MHz)	mV _{pp}	< 200
Power loss ¹	W	< 105
Weight	kg	4.8

¹ For an overview, see the power loss tables in Cabinet Design.

10.5 Voltage Clamping Module (VCM)

10.5.1 Description

Under certain unfavorable conditions, voltage rises can occur in extended drive line-ups due to the stimulation of the system resonance frequency. This can be particularly damaging for the insulation systems of the connected motors since partial discharges can occur.

The Voltage Clamping Module (VCM) ensures that the motor voltages are limited to permissible values even when resonance occurs. The Voltage Clamping Module must always be used if the total lengths of all the motor and DC link cables exceed the following value:

- 350 m for shielded cables.
- 560 m for unshielded cables.

In conjunction with the VCM, the following total cable lengths are permitted:

- 630 m for shielded cables
- 850 m for unshielded cables

Limitations/secondary conditions

The following secondary conditions must be observed:

- Power derating for Line Module to 80%.
- Max. step-up factor (rectification factor V_{dc}/V_{line}) with controlled infeed: 150%.
- No built-in motors must be connected (torque motors, linear motors).
- Operation on TN networks only.
- The EMC limit values (radio interference voltage) are no longer observed, which means that special measures may have to be implemented in the system.
On request: Line filter manufactured by, e-mail: emv.labor@epcos.com

Compatibility

The VCM can be integrated in the drive line-up with:

- Internal air cooling with mounting brackets (included in the scope of supply)
- External air cooling
- Cold plate cooling

10.5.2 Safety information



Warning

After disconnecting all the supply voltages, a hazardous voltage will be present in all components for another 5 minutes. The protective cover must not be opened until this time has elapsed.

When opening the protective cover for the DC link, you must activate the release. A suitable tool (e.g. screwdriver) must be used for this purpose.

The components must only be operated when the protective cover of the DC link is closed. Damaged components must not be used, otherwise this could result in secondary damage or accidents.



Caution

The VCM conducts a high leakage current via the functional ground. Because of the high leakage current of the VCM, a permanent PE connection of the VCM or switching cabinet (PE busbar) is required.

Measures according to EN 61800-5-1 must be taken (e.g. PE conductor ($\geq 10\text{mm}^2$ Cu) or fit an additional connection terminal for a PE conductor with the same cross-section as the original PE conductor).



Caution

The DC link discharge voltage hazard warning must be affixed to the modules in the local language.

A set of labels in 12 languages is available using order number: 6SL3166-3AB00-0AAx.

Notice

The 80 mm clearances above and below the components must be observed.

Caution

The tightening torque of the DC link busbar screws (1.8 Nm, tolerance: +30%) must be checked before startup. After transportation, the screws must be tightened.

Caution

The left and right ends of the DC link busbar of a drive line-up must be fitted with peripheral covers (order no.: 6SL3162-5AA00-0AA0).

10.5.3 Interface description

10.5.3.1 Overview

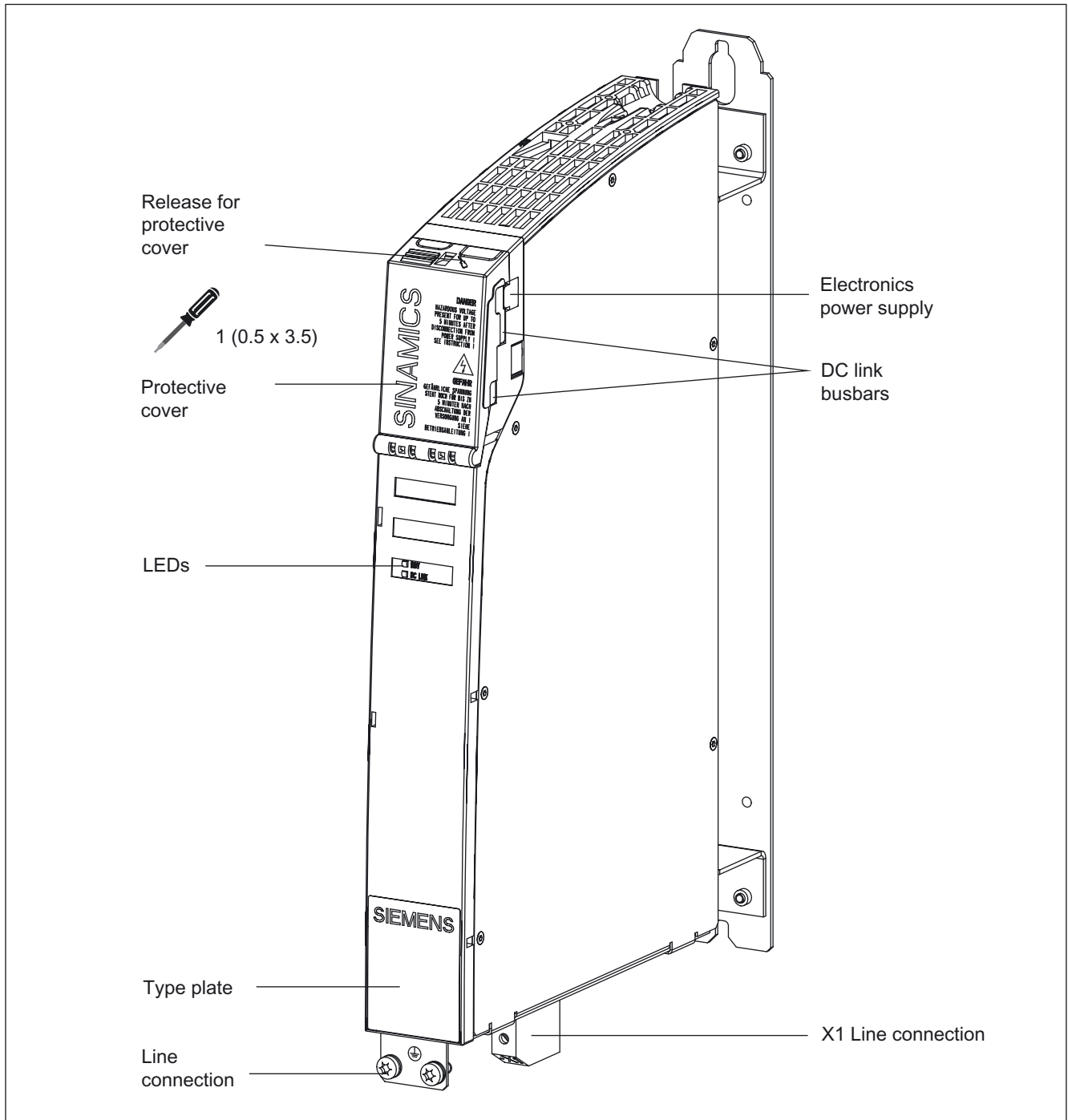

Figure 10-13 Interface description: Voltage Clamping Module

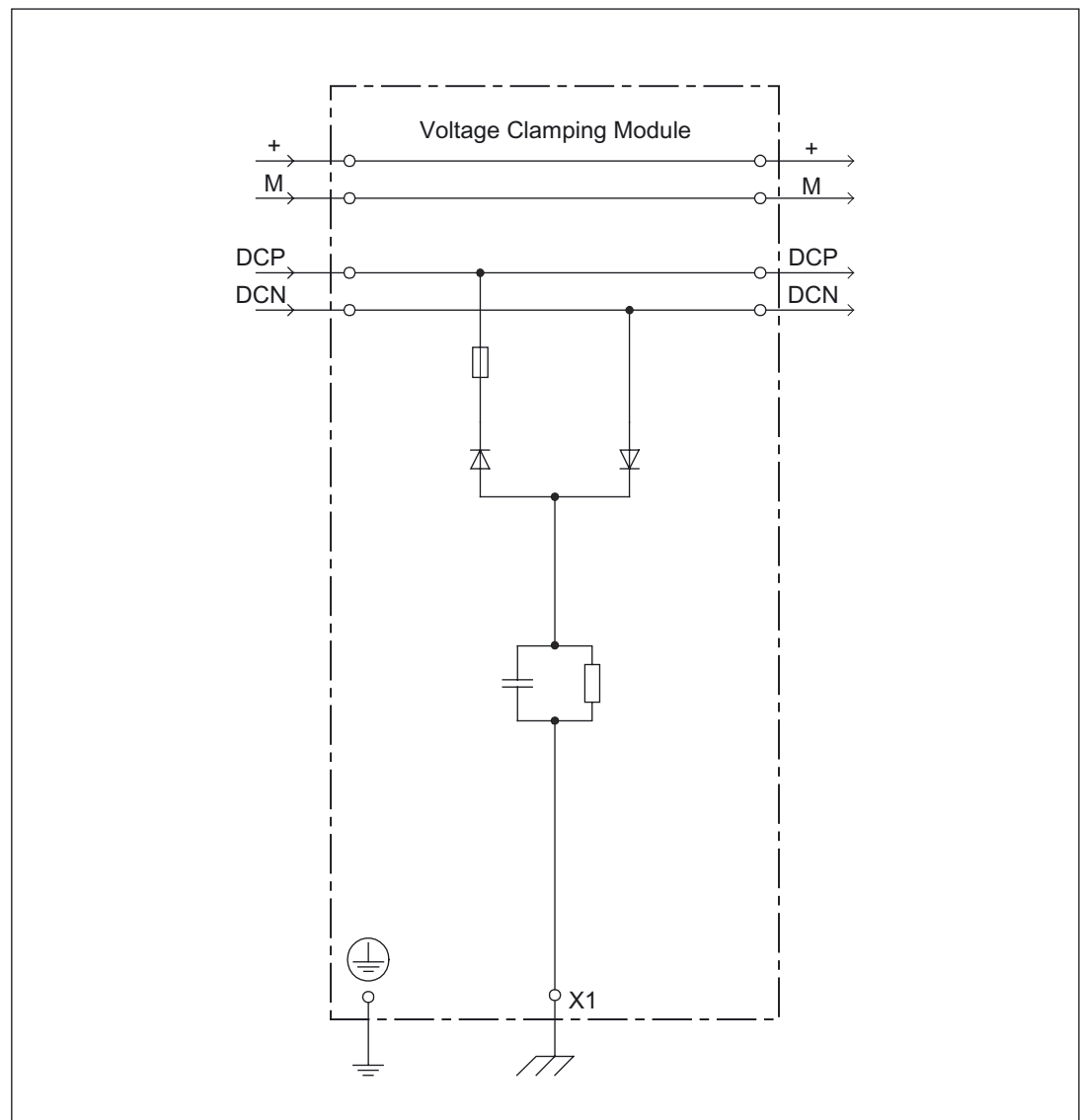

Figure 10-14 Circuit diagram: Voltage Clamping Module

10.5.3.2 X1 functional ground

X1 functional ground

To ensure that the Voltage Clamping Module functions properly, a functional ground must be connected to X1. Please note:

- The cables must be routed via the shortest possible path
- Cross-section: 4 mm² to 16 mm²
- When a line filter is used, the functional ground should be located on the metallic installation panel in the immediate vicinity of the line filter.
- In systems without a line filter, it should be connected on the PE busbar.

10.5.4 Dimension drawing

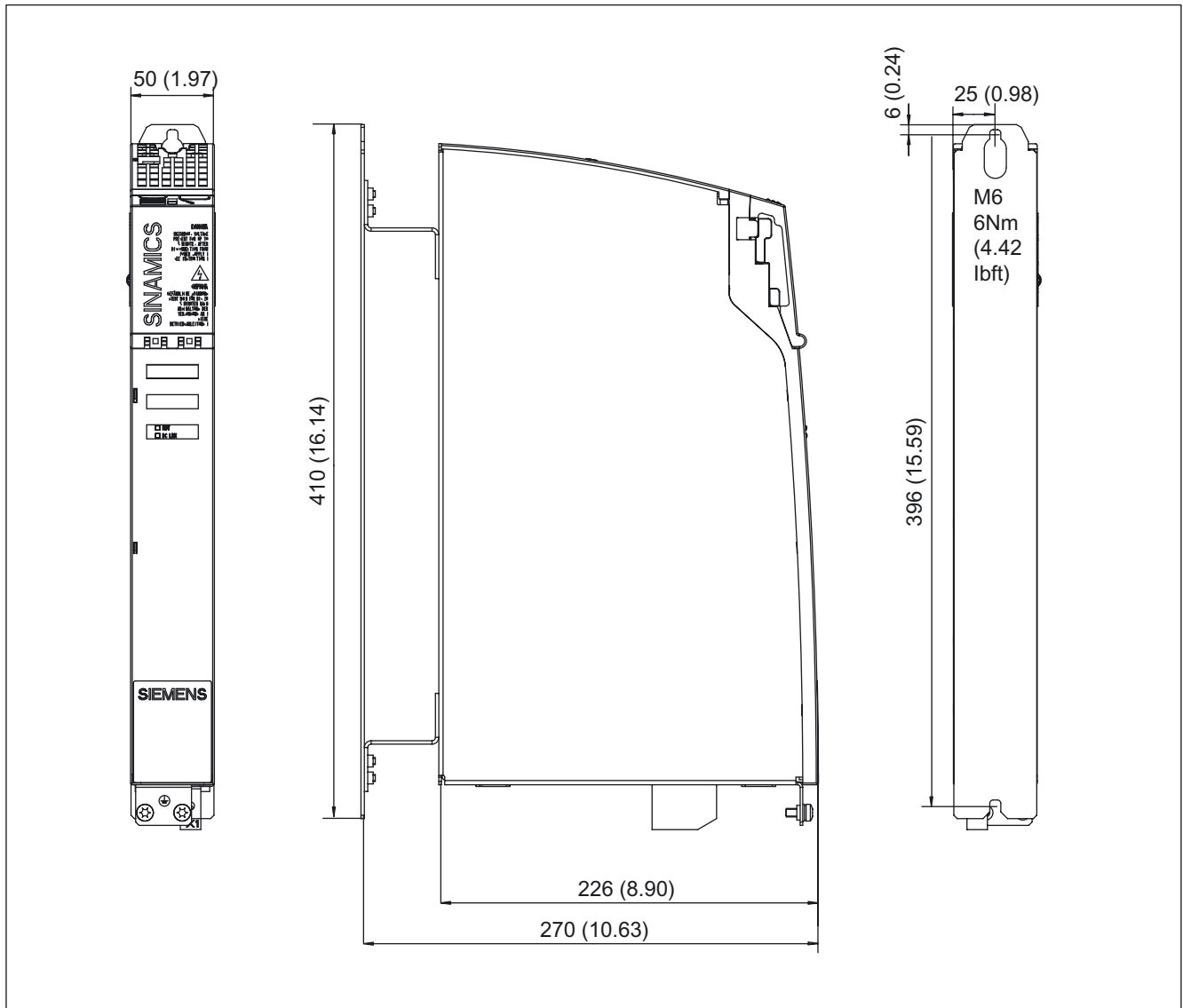

Figure 10-15 Dimension drawing of the Voltage Clamping Module

10.5.5 Installation

See the instructions for installing other DC link components (e.g. Braking Module, Capacitor Module).

Arrangement of the Voltage Clamping Module:

The Voltage Clamping Module should ideally be placed directly next to the Line Module.

- For Line Modules up to and including 36 kW, it should be placed to the right of the Line Module.
- For Active Line Modules as of 55 kW, it should be placed to the left of the Line Module due to the current-carrying capacity of the DC link busbars.
- If the Voltage Clamping Module is to be installed in an existing drive line-up, it can also be placed at the end.

10.5.6 Technical specifications

Table 10-10 Technical Specifications

Voltage Clamping Module		
Electronics power supply	V _{DC}	24 (20.4 - 28.8)
DC link voltage	V _{DC}	510 - 750
DC link busbar current carrying capacity	A	100
24 V busbar current carrying capacity	A	20
Power loss ¹	W	50
Weight	kg	3.1

¹ For an overview, see the power loss tables in Cabinet Design.

Options

11.1 Shielded terminal plates

11.1.1 Description

The line and motor cable shields are connected to the shielded terminal plates. This ensures EMC compliance.

11.1.2 Overview

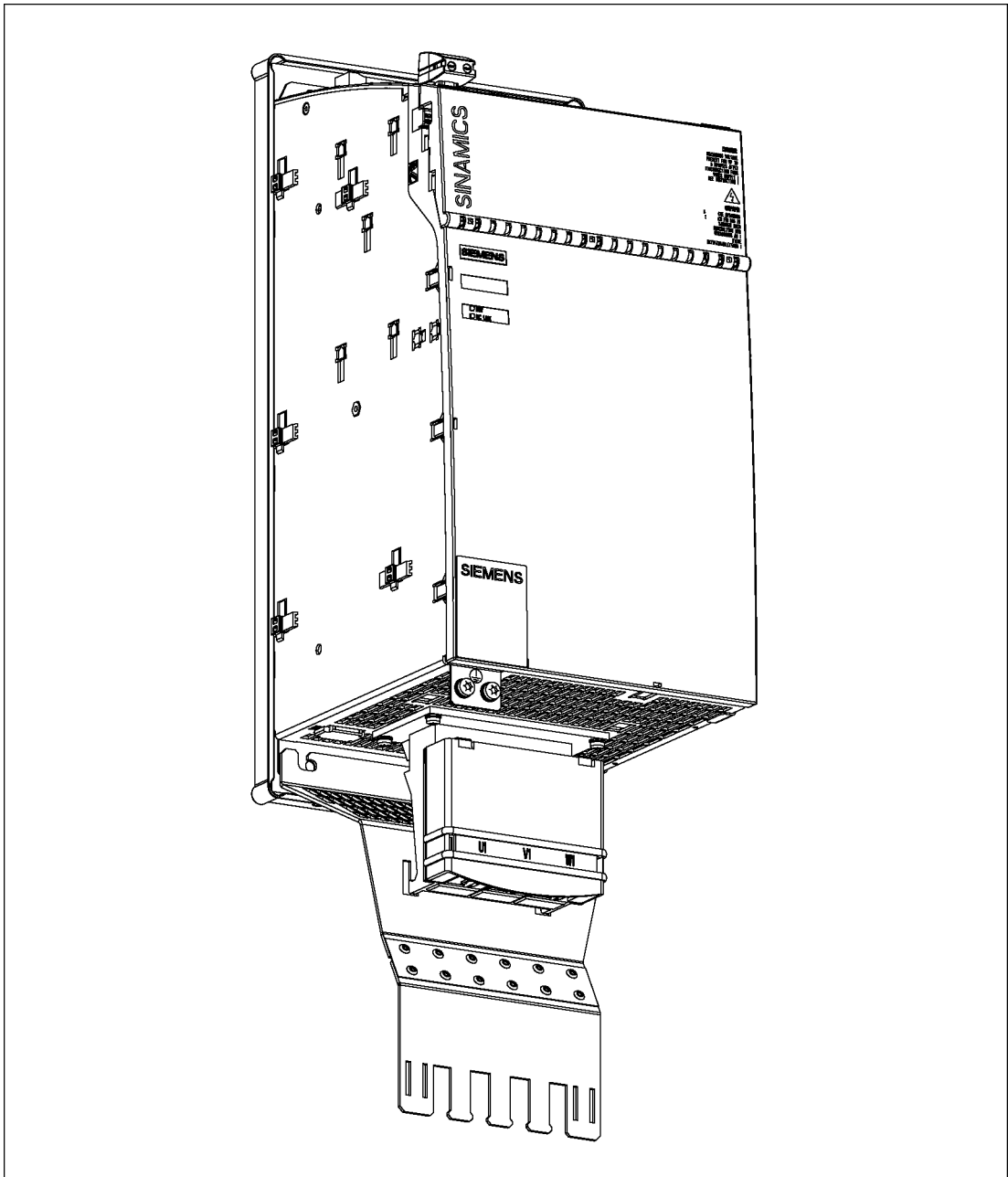

Figure 11-1 Shielded terminal plate for a 200 mm module with with a cold plate

11.1.3 Dimension Drawings

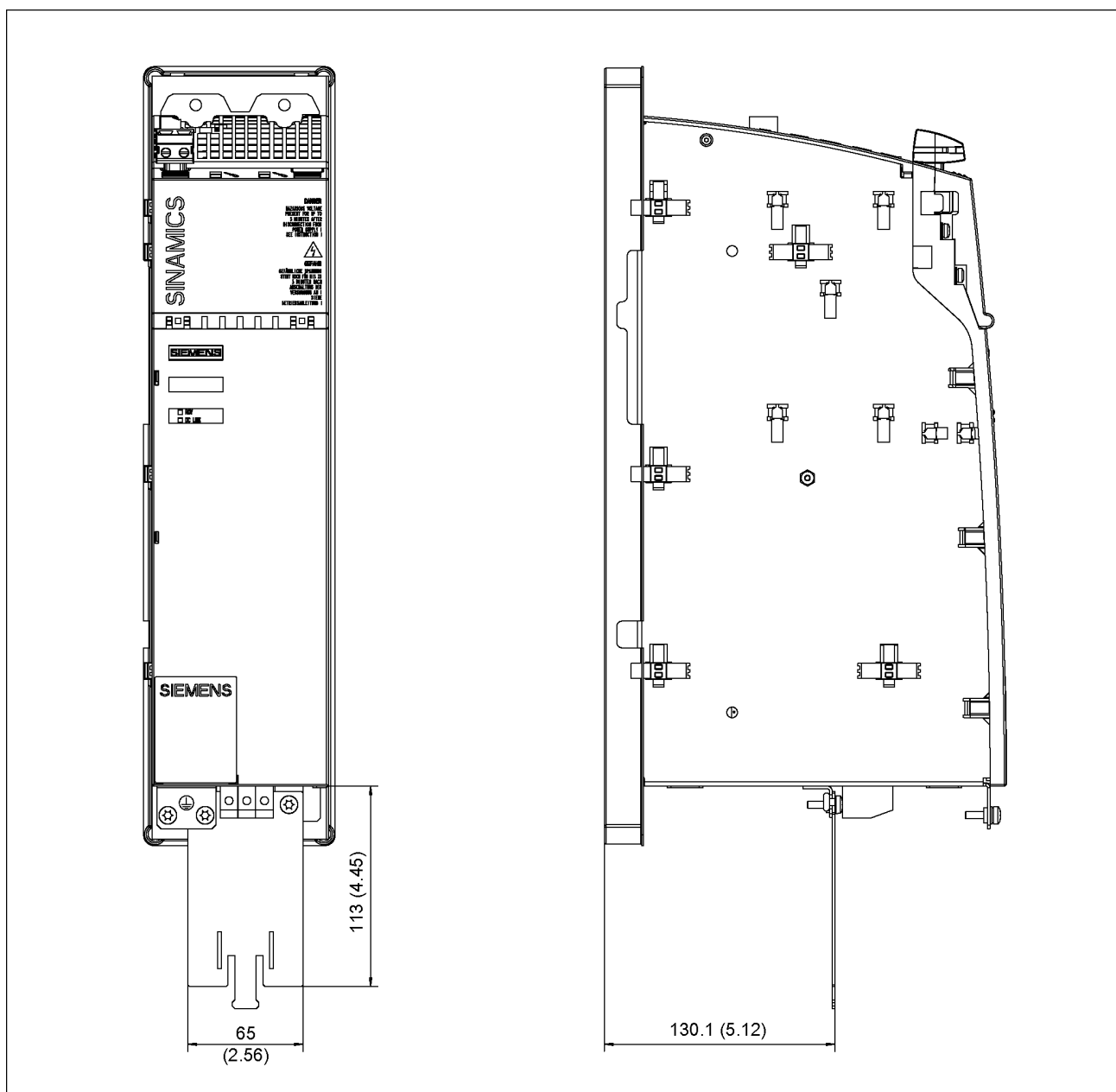

Figure 11-2 Dimension drawing of shielded terminal plate on a 100 mm module with cold plate

Note

The shielded terminal plate is part of the scope of supply for a 100 mm Line Module.

Recommended shield contacts: from Weidmüller, order no. KLBÜ CO4

Weidmüller: <http://www.weidmueller.com>

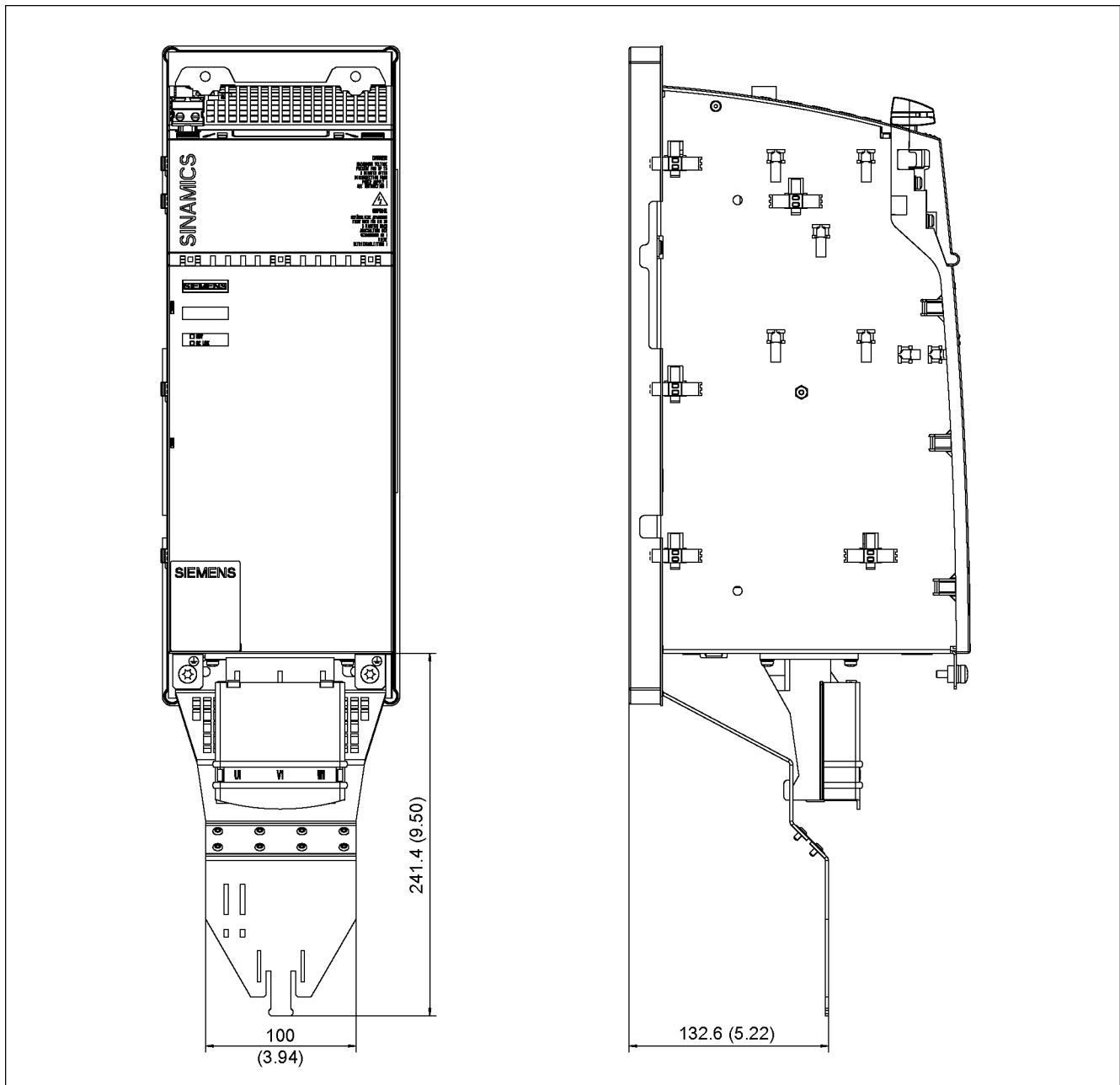

Figure 11-3 Dimension drawing of shielded terminal plate on a 150 mm module with cold plate

Note

Recommended shield contacts: from Weidmüller, order no. KLBÜ CO1 and KLBÜ CO4

Weidmüller: <http://www.weidmueller.com>

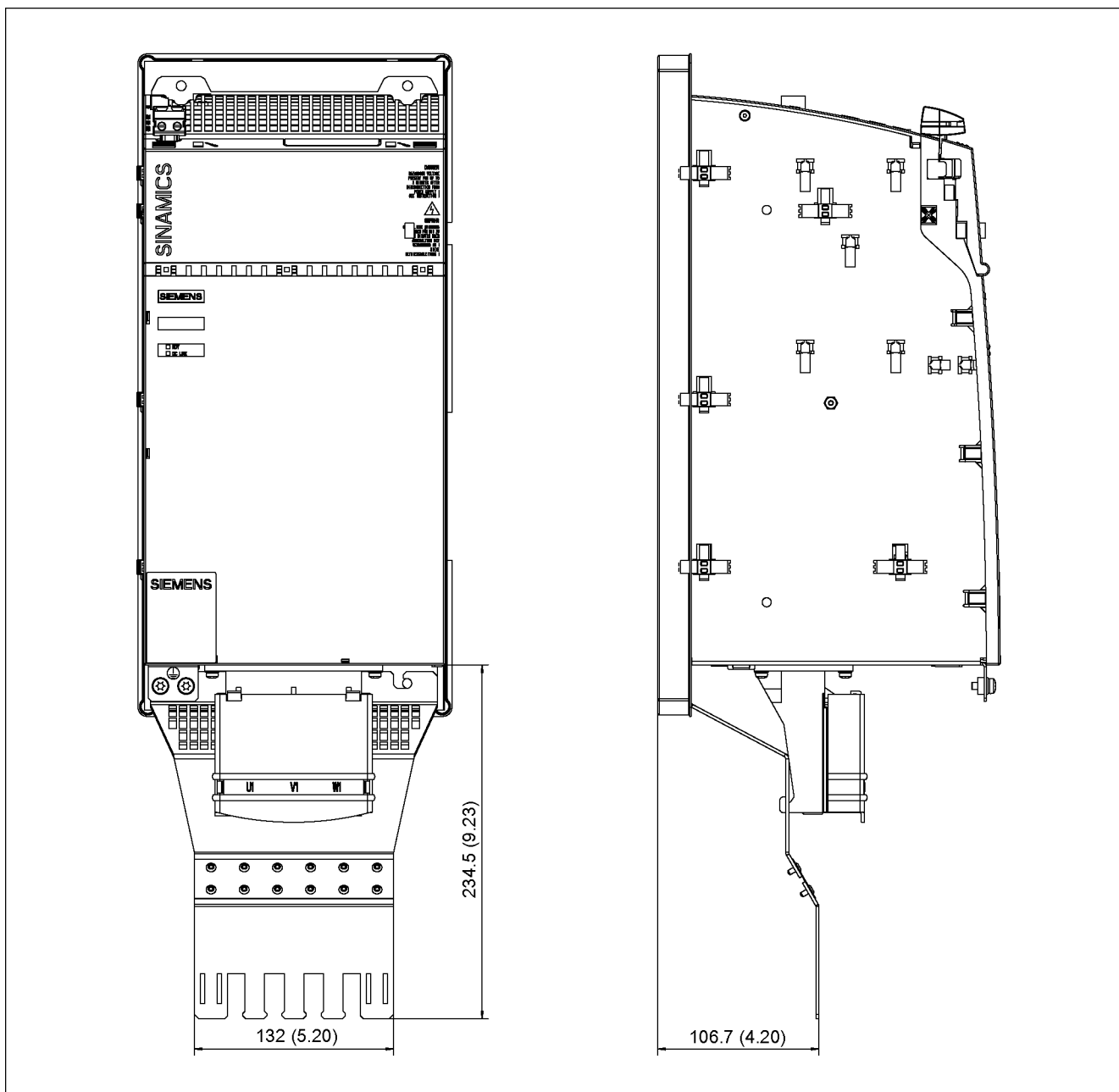

Figure 11-4 Dimension drawing of shielded terminal plate on a 200 mm module with cold plate

Note

Recommended shield contacts: from Weidmüller, order no. KLBÜ CO1

Weidmüller: <http://www.weidmueller.com>

11.1 Shielded terminal plates

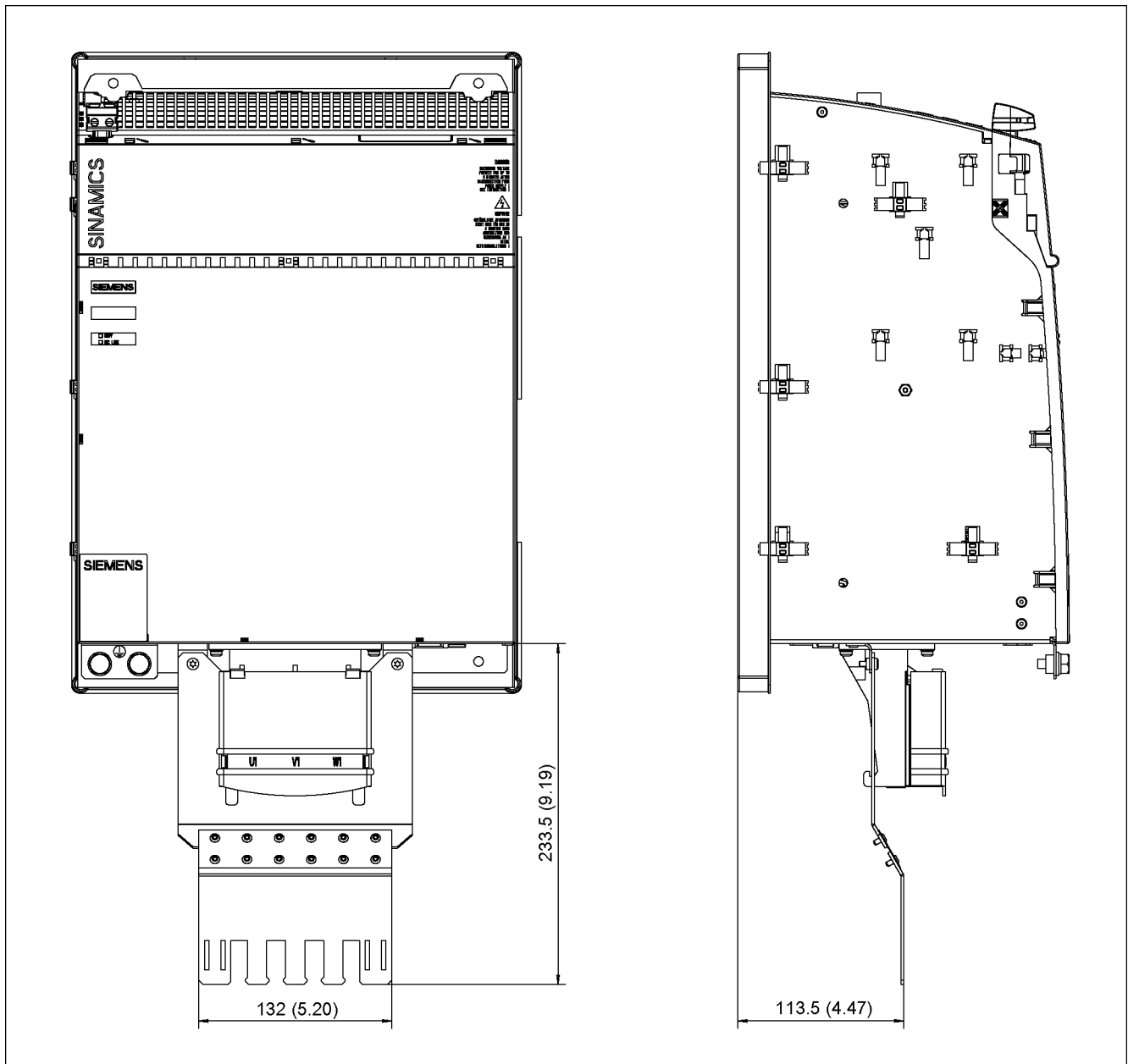

Dimension drawing of shielded terminal plate on a 300 mm module with cold plate



Note

Recommended shield contacts: from Weidmüller, order no. KLBÜ CO1

Weidmüller: <http://www.weidmueller.com>

11.1.4 Installation

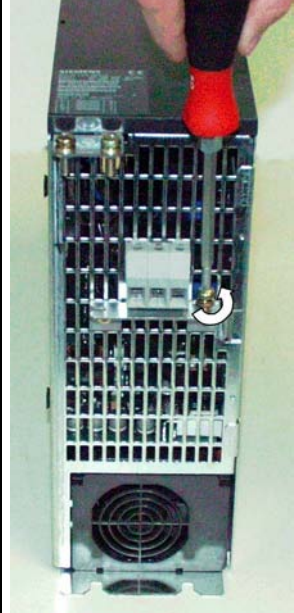
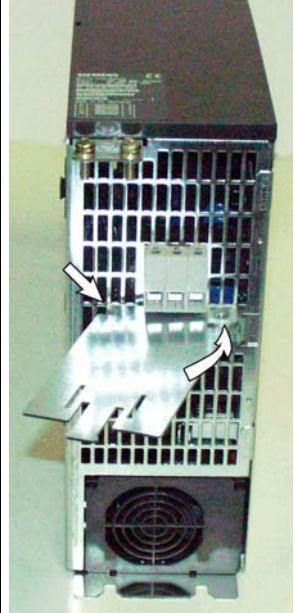
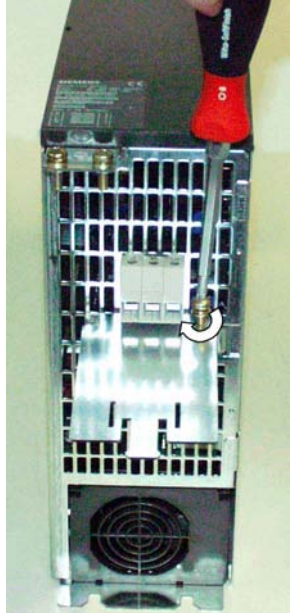
Table 11-1 Installing the shielded terminal plate on a 100 mm module (e.g. with internal air cooling)

			
<p>Unscrew the screw with screwdriver T25.</p>	<p>Hook in the shielded plate.</p>	<p>Secure the shielded terminal plate with screwdriver T25/3 Nm.</p>	<p>The shielded terminal plate is installed.</p>

Options

11.1 Shielded terminal plates

Table 11-2 Installing the shielded terminal plate on a 200 mm module (e.g. with internal air cooling)



		
<p>Loosen the lower mounting screws using a screwdriver.</p>	<p>Hook the shielded terminal plate into the screws and on the line/motor connection.</p>	<p>Secure the shielded terminal plate by shifting it to the left.</p>
		
<p>Secure the shielded terminal plate with screwdriver 6 Nm.</p>	<p>The shielded terminal plate is installed.</p>	

Table 11-3 Installing the shielded terminal plate on a 300 mm module (e.g. with internal air cooling)



Unscrew the screw with screwdriver T25.

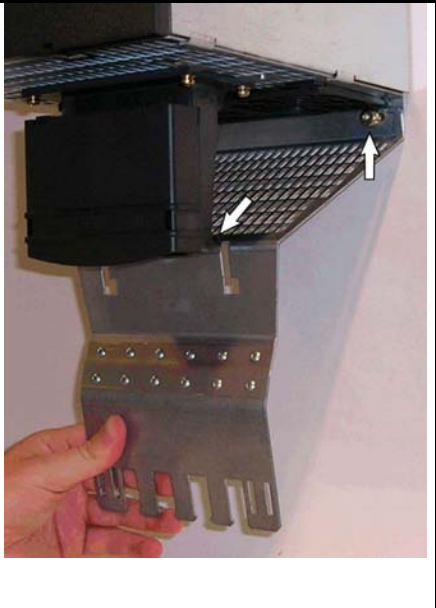
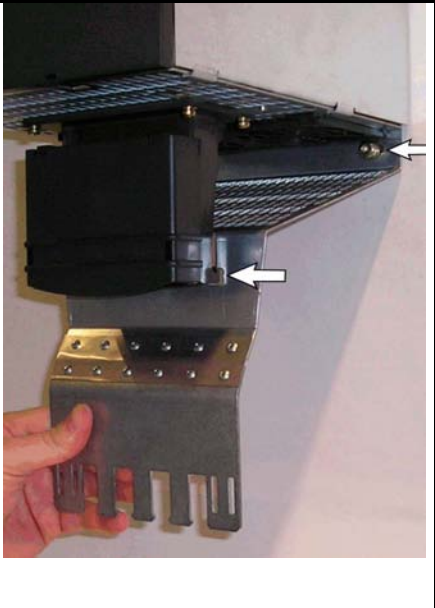

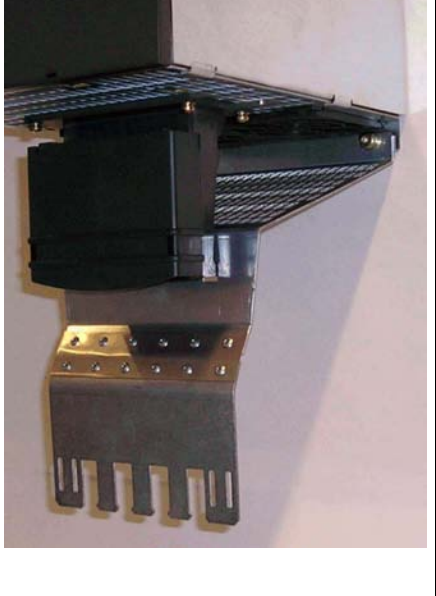
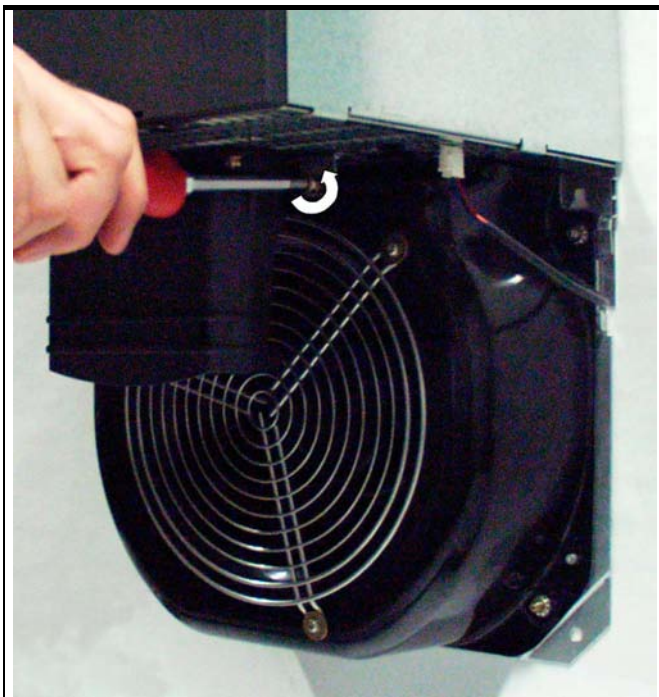
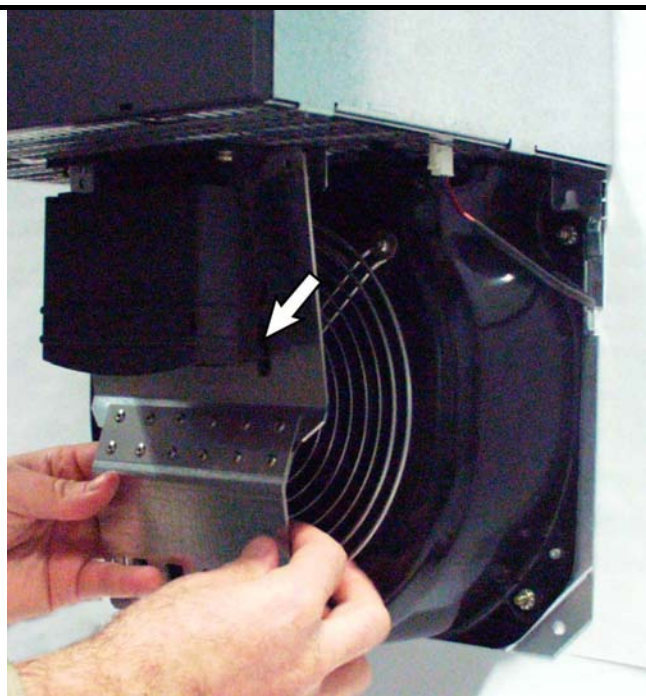
Hook the shielded terminal plate into the line/motor connection.

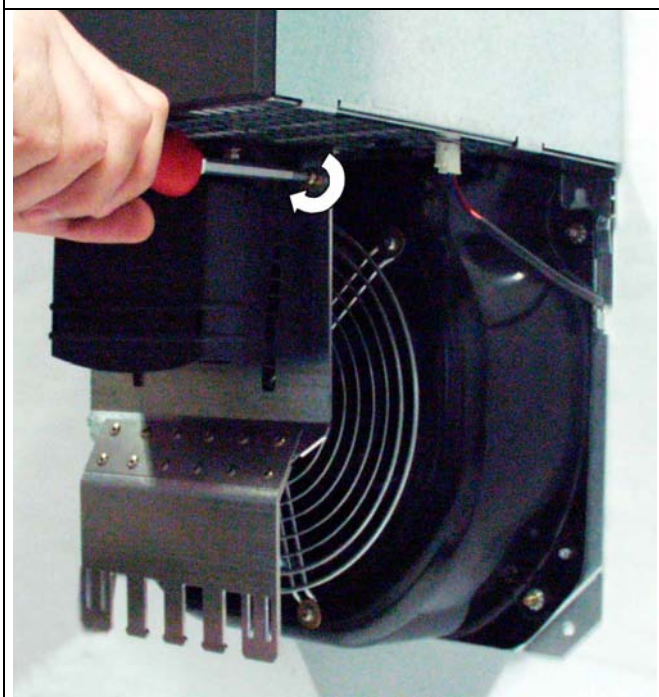

Secure the shielded terminal plate with screwdriver T25/3 Nm.

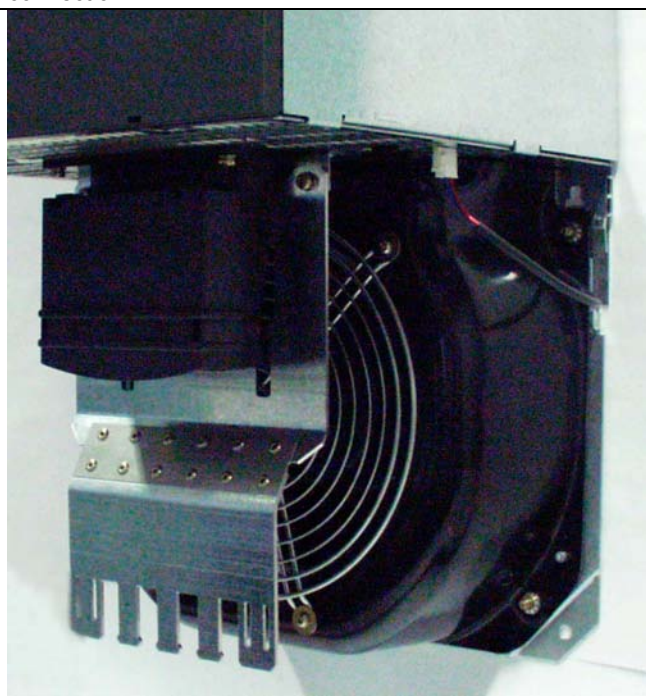

The shielded terminal plate is installed.

11.1.5 Electrical Connection

Table 11-4 Electrical connection to shielded terminal plate for 100 mm module (e.g. with internal air cooling)



			
Secure the earthing cable with screwdriver T25/3 Nm.	Secure the power cable with flat-bladed screwdriver 4/1.8 Nm.	Secure the shield clip to the shielded terminal plate using a suitable tool.	The power cable is connected.

Table 11-5 Electrical connection to shielded terminal plate for 200 mm module (e.g. with internal air cooling)

		
<p>Unlock and remove the cover of the terminal block.</p>	<p>Remove nuts M8 using a suitable tool.</p>	<p>Secure the earthing cable with screwdriver T25 and the power cable with torque spanner M8/13 Nm.</p>
		
<p>Adjust the shock-hazard protection using a suitable tool.</p>	<p>Attach the shock-hazard protection.</p>	<p>Secure the shield clip to the shielded terminal plate using a suitable tool.</p>

		
<p>Close the cover of the terminal block.</p>		

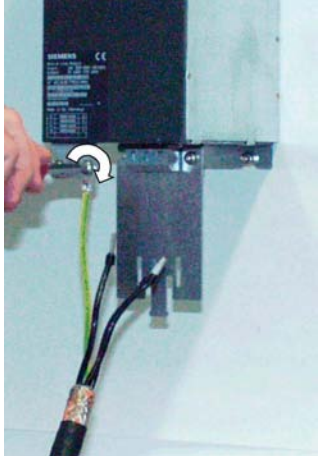
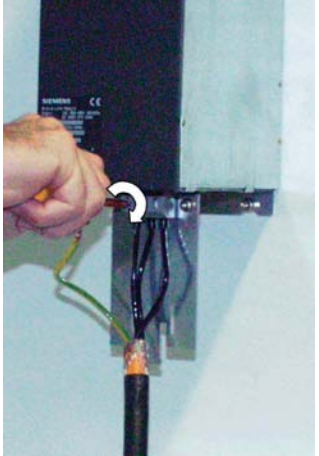
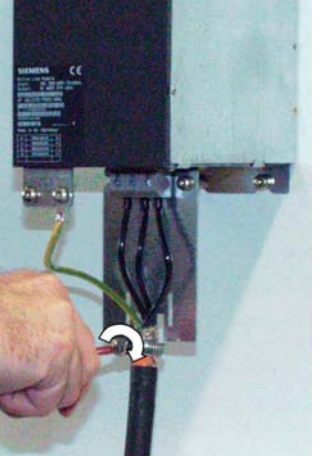
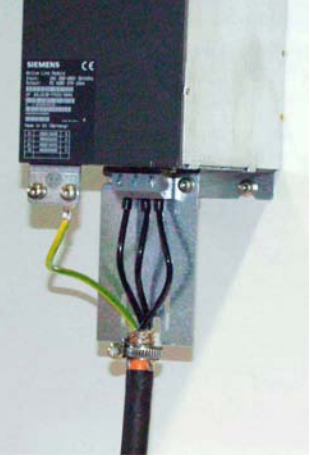
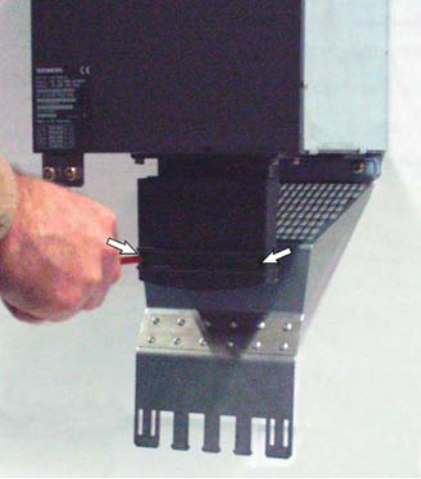
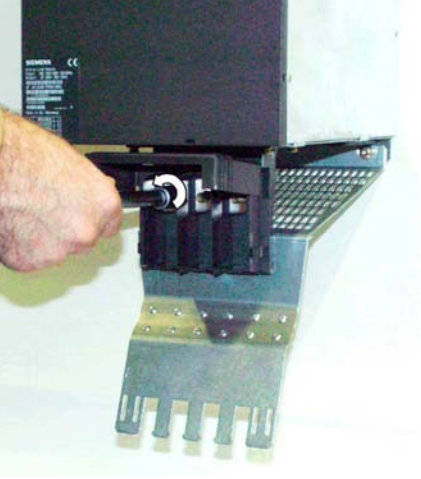
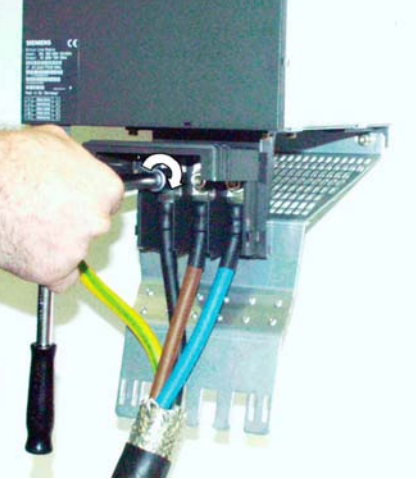
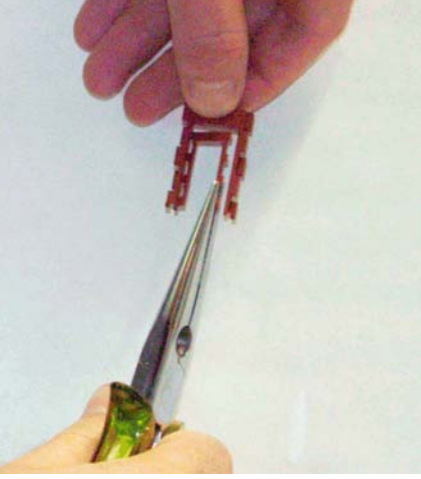
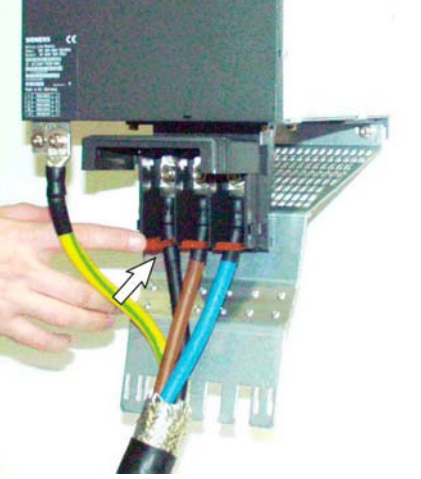
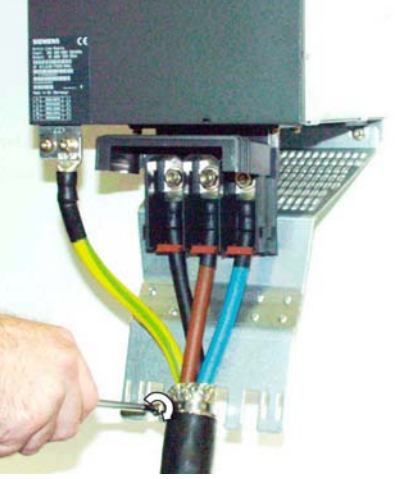
11.2 DC link supply adapter

11.2.1 Description

The DC link supply adapter supplies the DC link voltage directly. With a direct supply, each module is connected to the DC link separately. The internal DC link busbar is not used here. The connection cables must be fused accordingly.

Note

When a DC link supply adapter and DC busbars are used, the limit values for radio interference emission to EN 55011 cannot be observed.

It is not possible to use the DC link supply adapter in conjunction with internal DC link busbars.

Table 11-6 The DC link supply adapter is available in two sizes.

<p>for Line/Motor Modules with a width of 50 mm and 100 mm</p>	<p>for Line/Motor Modules with a width of 150 mm, 200 mm, 300 mm</p>
<p>Screw terminals (4 to 10 mm²)</p>	<p>Screw terminals (35 to 95 mm²)</p>

11.2.2 Safety Information



Danger

A hazardous voltage is present for 5 minutes after the power supply has been disconnected. The adapter cannot be installed until this time has elapsed.

When opening the protective cover for the DC link, you must activate the release. A suitable tool (e.g. screwdriver) must be used for this purpose.

The components must only be operated when the protective cover of the DC link is closed. Damaged components must not be used, otherwise this could result in secondary damage or accidents.



Danger

Components for which the recesses for the DC link supply adapter have been removed must no longer be operated without them. If components need to be operated without neither the recess nor DC link supply adapter, the DC link cover must be replaced.

Caution

The DC link discharge voltage hazard warning on the modules on which the adapter is installed must be in the local language.

A set of labels in 12 languages is available using order number: 6SL3166-3AB00-0AAx.

Caution

The screw tightening torque (1.8 Nm, tolerance: +30%) for securing components to the module-side DC link busbar must be checked before commissioning to ensure that it is correct. After transportation, the screws must be tightened.

Caution

To ensure safe electrical separation, the 24 V supply cables and those for the DC link connection cables must be physically separated (> 100 mm), or the 24 V cables must be doubly insulated (e.g. light plastic-sheathed cable).



Warning

The DC link connection cables must be routed in such a way as to ensure that they are ground-fault and short-circuit proof in accordance with DIN/VDE 0100 or suitable fuse protection must be provided.

Caution

The total length of the DC link (including the connection cables) must not exceed 10 m.

11.2.3 Interface description

11.2.3.1 Overview

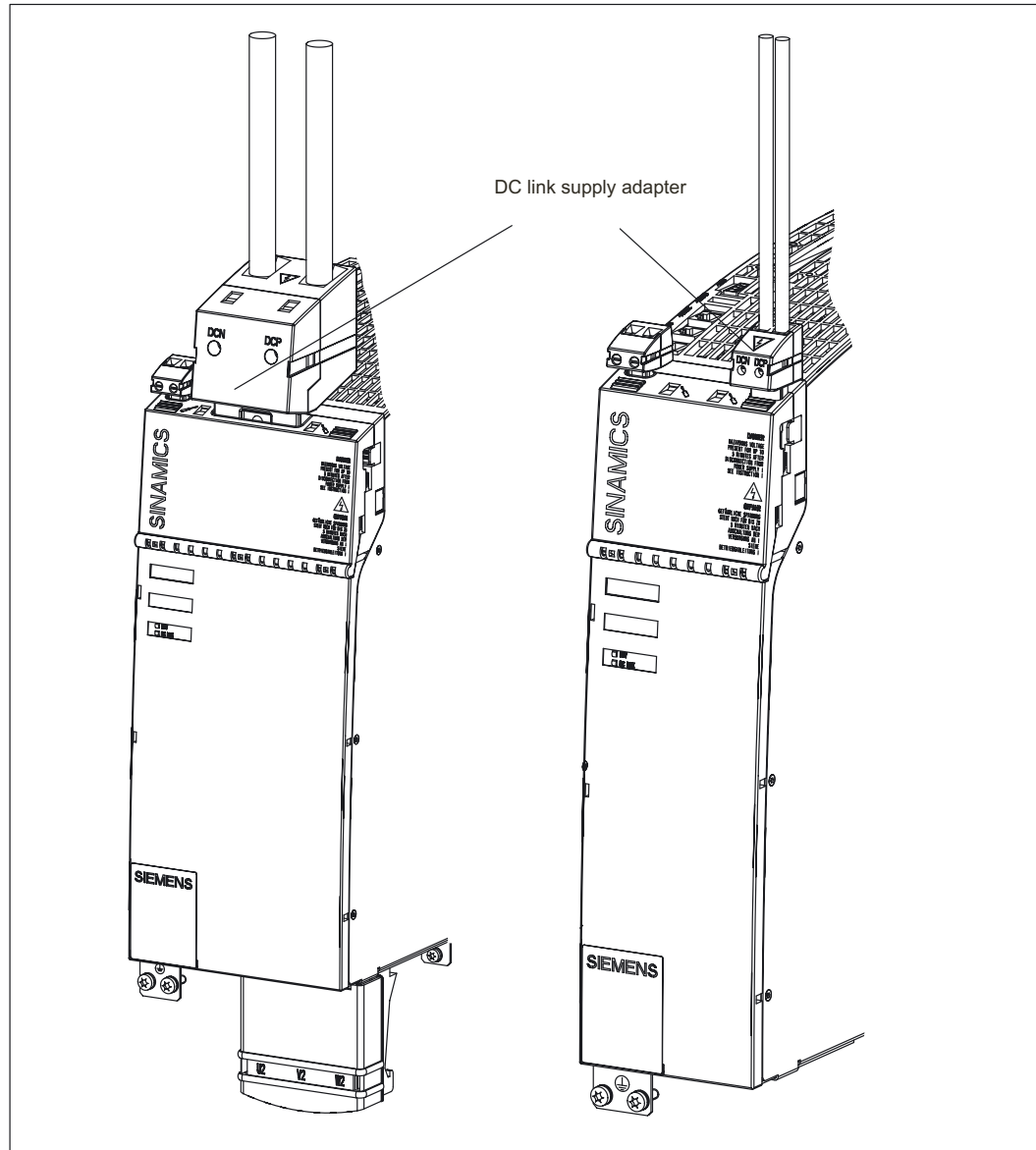

Figure 11-5 150 mm modules with DC link supply adapter for 35 mm² to 95 mm² and 100 mm modules with DC link supply adapter for 4 mm² to 10 mm²

11.2.3.2 DC link connection

Table 11-7 DC link supply adapter – description of the terminals

Terminal	Function	Technical specifications
DCP	DC link positive	Connection voltage: 750 V-VDE/600 V-UL Direct supply 4 – 10 mm² Current carrying capacity: 36 A Connection cross-section: 4 – 10 mm ² Stripped length: 11 mm Direct supply 35 – 95 mm² Current carrying capacity: 240 A Connection cross-section: 35 – 95 mm ² Stripped length: 27 mm
DCN	DC link negative	

11.2.4 Dimension Drawings

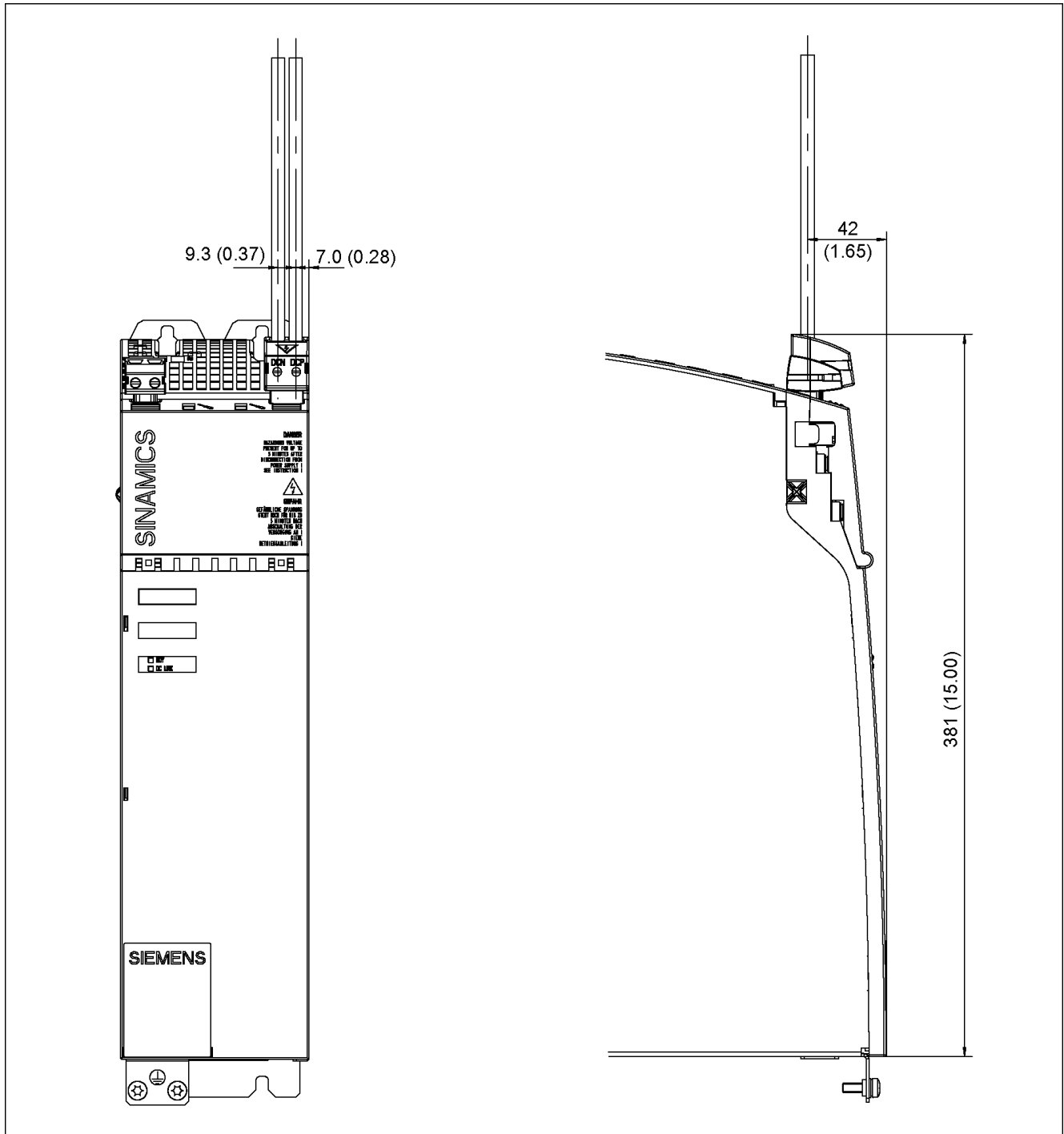

Figure 11-6 Dimension drawing of 100 mm module with DC link supply adapter for 0.5 mm² to 10 mm²

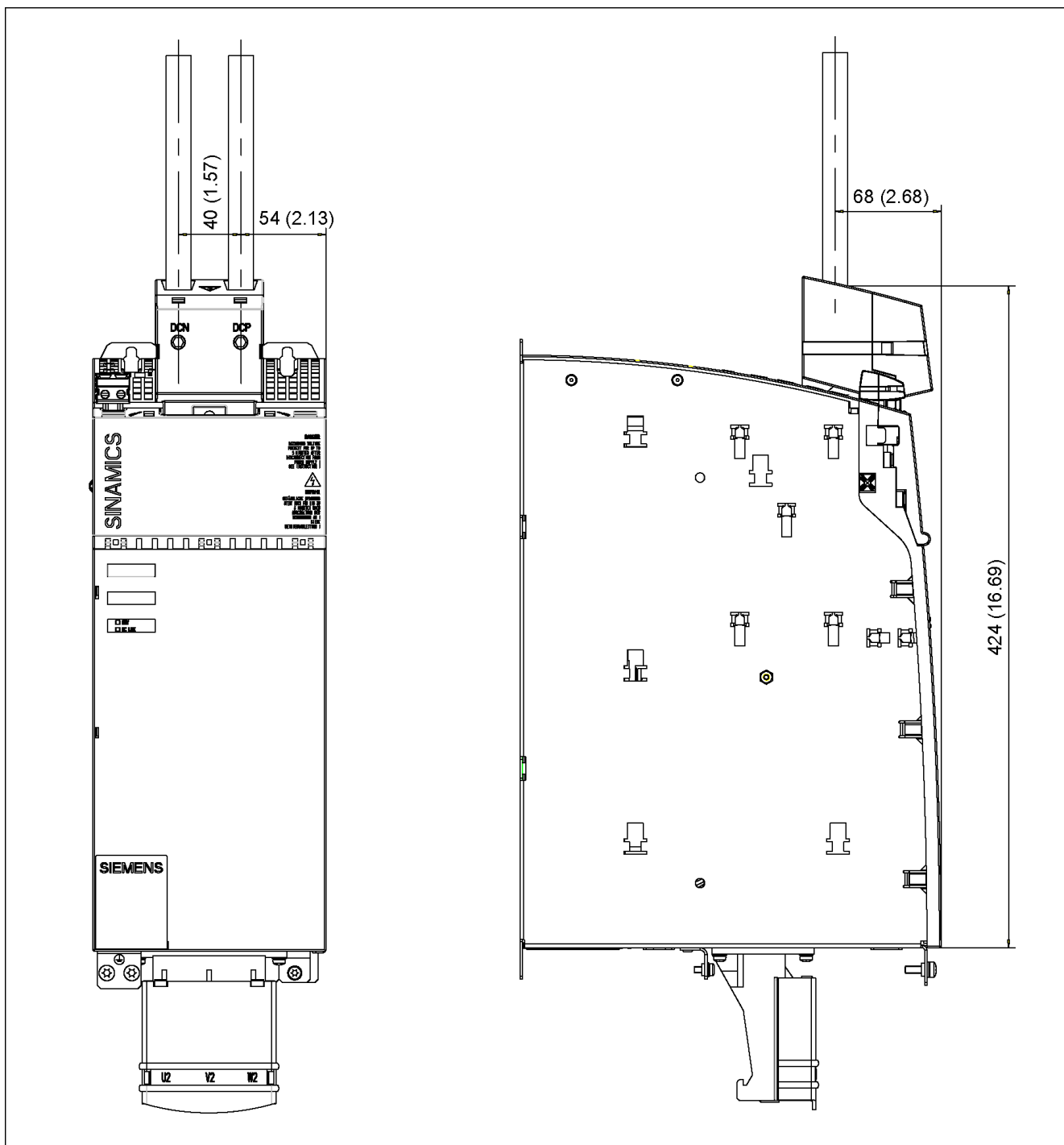

Figure 11-7 Dimension drawing of 150 mm module with DC link supply adapter for 35 mm² to 95 mm²

11.2.5 Installation

Required tools:

- Flat-bladed screwdriver 1 (0.5 x 3.5)
- Torx screwdriver T10
- Torx screwdriver T20

Table 11-8 Installing the DC link supply adapter for 50 mm and 100 mm modules





			
<p>Unlock and open the protective cover.</p>	<p>Opened cover with 24 V jumper and DC link bridge.</p>	<p>The DC link bridge and 24 V jumper have been removed.</p>	
			
<p>Secure the adapter.</p>	<p>Create the recess using suitable pliers.</p>	<p>Attach the 24 V adapter.</p>	<p>Close the protective cover.</p>

Table 11-9 Installing the DC link supply adapter for 150 mm, 200 mm, and 300 mm modules

Unlock and open the protective cover.	Opened cover with 24 V jumper	Remove the 24 V jumper and unscrew the DC link screws.
Hook in the adapter.	Secure the adapter.	The adapter has been screwed in.
Create the recess using suitable pliers.	Attach the 24 V adapter.	Close the protective cover.

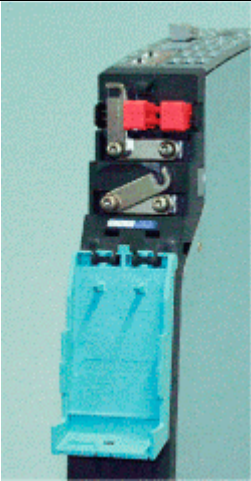
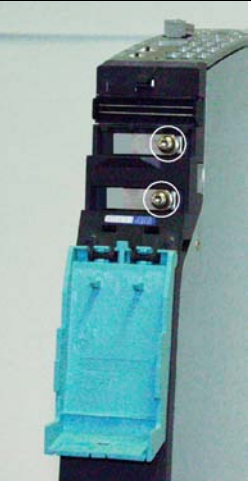
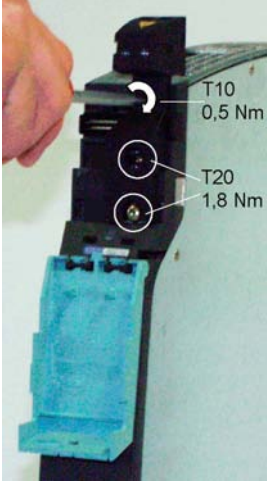
11.2.6 Electrical Connection

Table 11-10 Connecting the DC link supply adapter for 50 mm and 100 mm modules

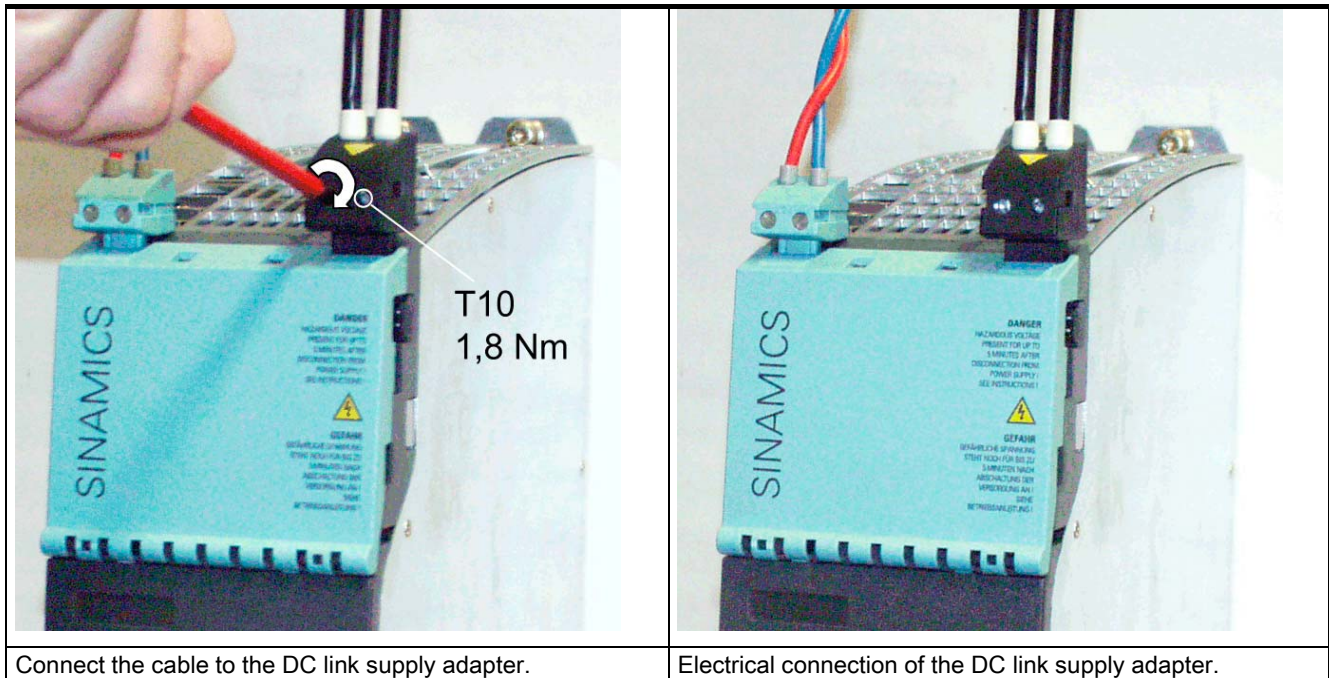
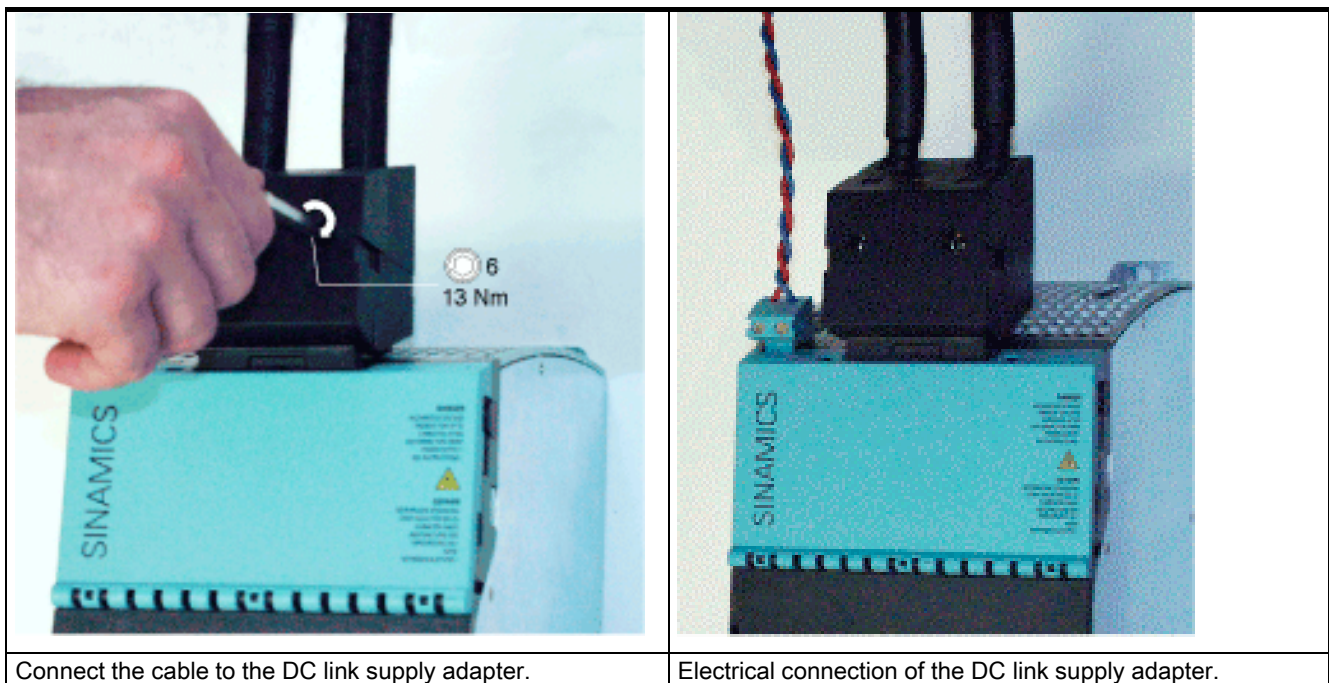

Table 11-11 Connecting the DC link supply adapter for 150 mm, 200 mm, and 300 mm modules



11.3 DC link adapter

11.3.1 Description

The DC link adapter is required when the drive line-up needs to be divided up (e.g. into two rows). The sub-line-ups are connected using cables (35 mm² to 95 mm²). Shielded individual cores are recommended.

The DC link adapter can be used for all line modules/motor modules in booksize format.

11.3.2 Safety Information



Danger

A hazardous voltage is present for 5 minutes after the power supply has been disconnected. The adapter cannot be installed until this time has elapsed.

The components must only be operated when the protective cover of the DC link is closed. Damaged components must not be used, otherwise this could result in secondary damage or accidents.

Caution

The DC link discharge voltage hazard warning on the modules on which the adapter is installed must be in the local language.

A set of labels in 12 languages is available using order number: 6SL3166-3AB00-0AAx.

Caution

The screw tightening torque (1.8 Nm, tolerance: +30%) for securing components to the module-side DC link busbar must be checked before commissioning to ensure that it is correct. After transportation, the screws must be tightened.



Warning

The DC link connection cables must be routed in such a way that they are ground-fault and short-circuit proof in accordance with DIN/VDE 0100.

Caution

The total length of the DC link (including the connection cables) must not exceed 10 m.

11.3.3 Interface description

11.3.3.1 Overview

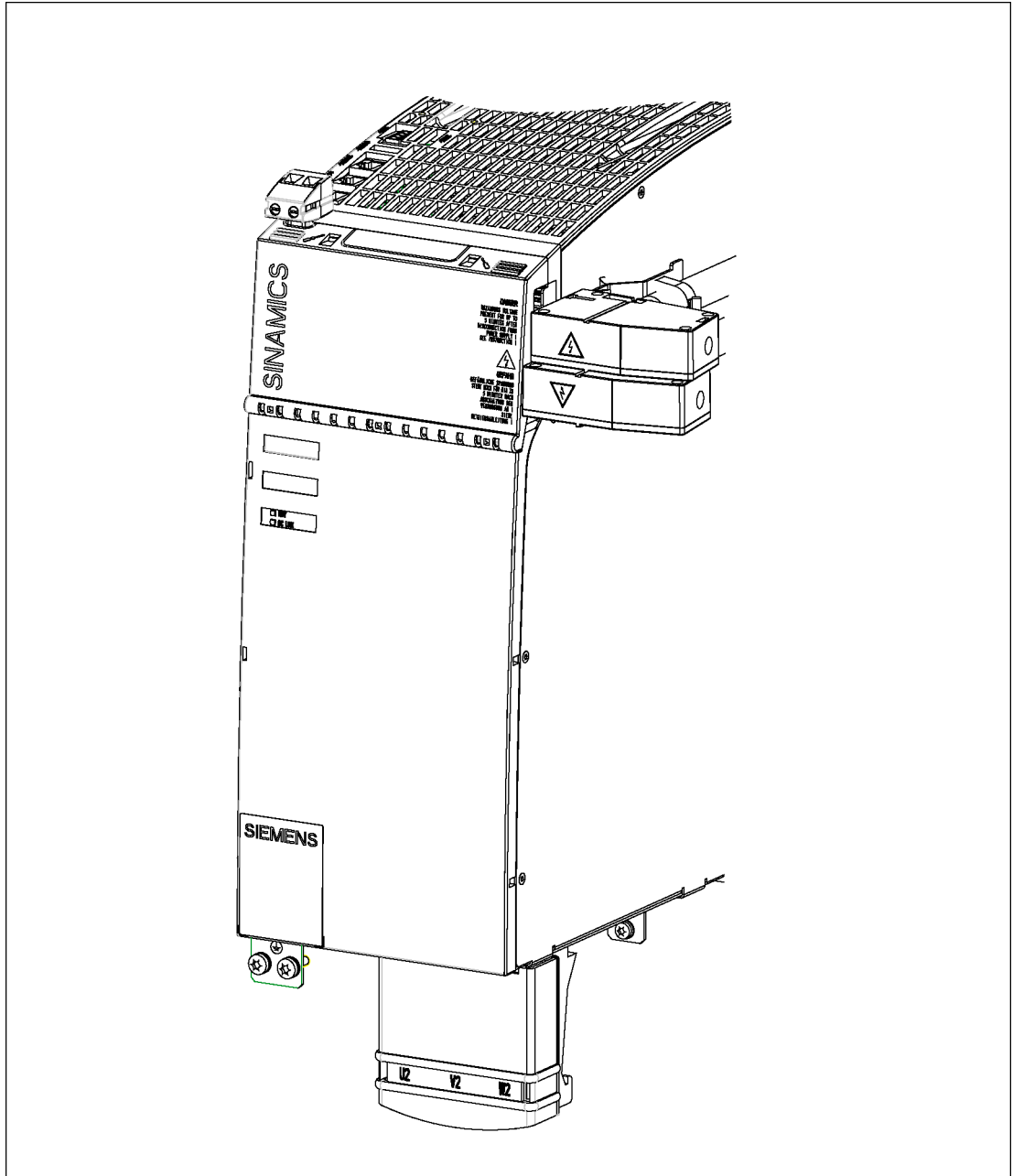

Figure 11-8 150 mm module with DC link adapter for two-row configuration (35 mm² to 95 mm²)

11.3.3.2 DC link connection

Table 11-12 DC link adapter – description of the terminals

Terminal	Function	Technical specifications
DCP	DC link positive	Two-row configuration of adapter 35 – 95 mm² Current carrying capacity: 240 A Voltage: 750 V-VDE/600 V AC Connection cross-section: 35 – 95 mm ² Stripped length: 27 mm
DCN	DC link negative	

11.3.4 Dimension Drawing

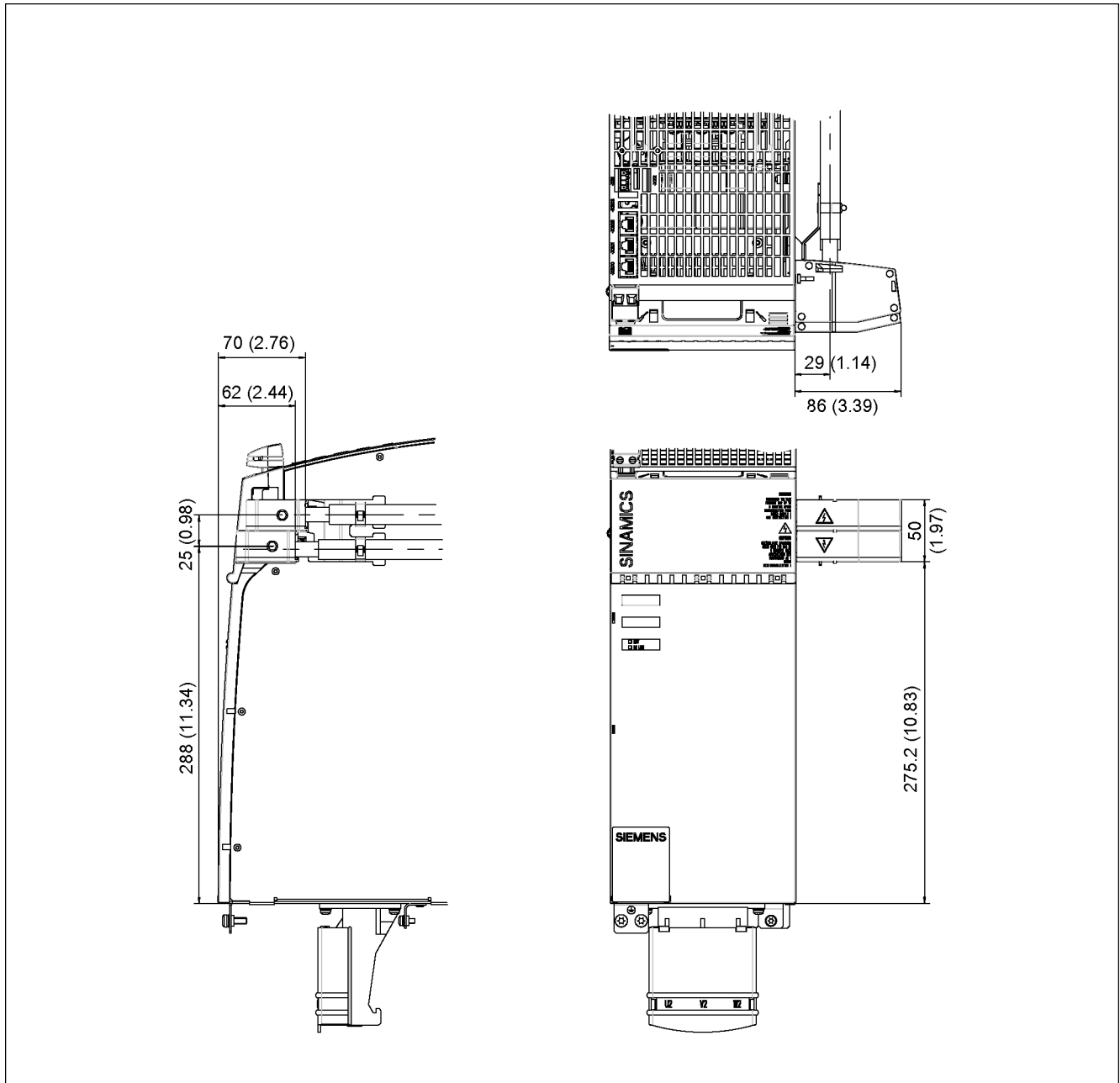

Figure 11-9 Dimension drawing of 150 mm module with DC link adapter for two-row configuration (35 mm² to 95 mm²)

11.3.5 Installation

Required tools:

- Torx screwdriver T20
- Flat-bladed screwdriver 1 (0.5 – 3.5)

Table 11-13 Installing the DC link adapter for a 150 mm module

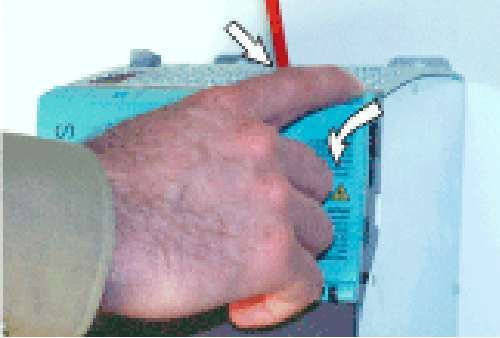
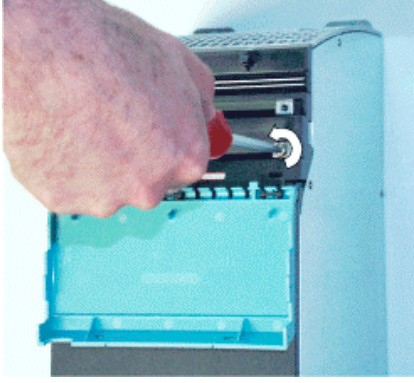
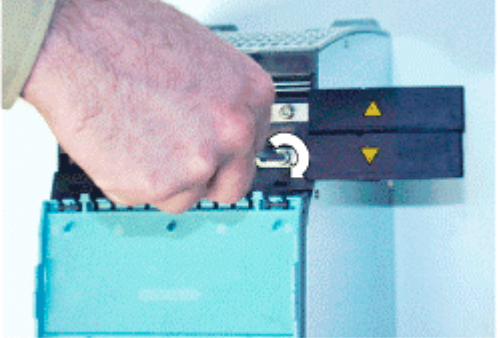
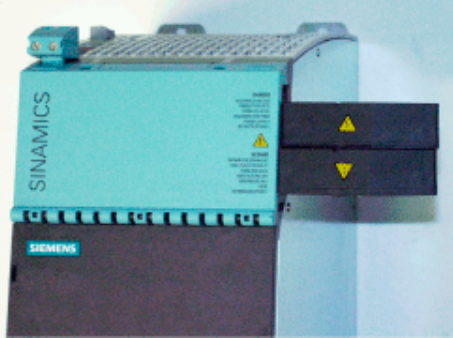
	
<p>Unlock and open the protective cover.</p>	<p>Unscrew the screws.</p>
	
<p>Secure the adapter (1.8 Nm).</p>	<p>The 24 V adapter is installed and the protective cover is closed.</p>

Note:

By moving the adapter housing, the DC link adapter can be fitted on either the left-hand or right-hand side of the module. This is possible with Active Line Modules as of 55 kW; refer to the overview below.

Table 11-14 Overview

Active Line Module	With cold-plate cooling
55 kW	6SL3136-7TE25-5AA1
80 kW	6SL3136-7TE25-5AA1
120 kW	6SL3136-7TE31-2AA1

11.3.6 Electrical Connection

Required tools:

- Hexagon-socket spanner (size 6)
- Suitable tool for tube clips (e.g. flat-bladed screwdriver)

Table 11-15 Electrical connection of the DC link adapter for a 150 mm module

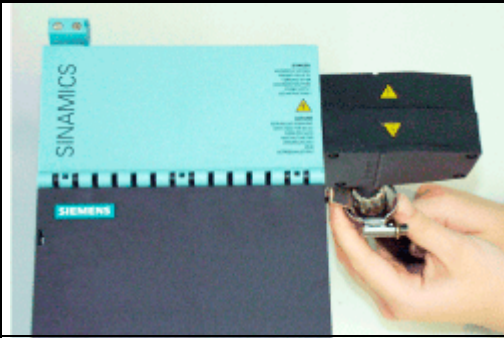
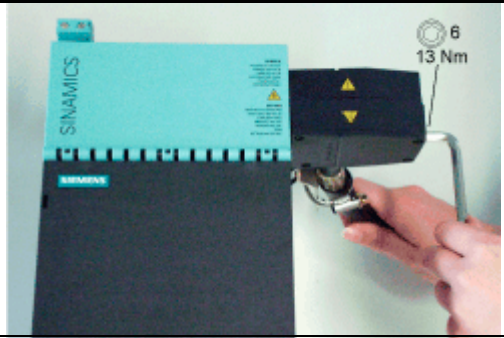
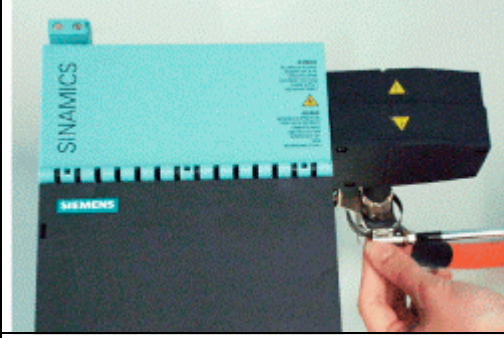
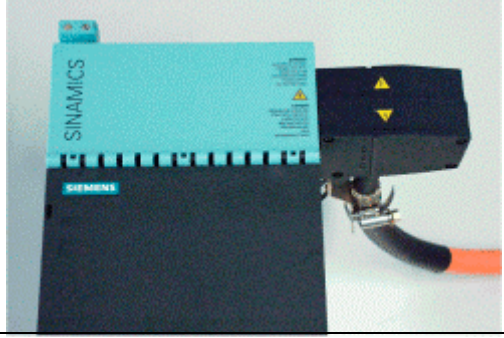
	
Route the cable through the tube clip and insert it into the DC link adapter.	Secure the cable.
	
Secure the tube clip.	The cable is connected.

Only shielded connection cables should be used.

The DC link adapter can be fitted on the right or left.

11.4 DRIVE-CLiQ Flanged Coupling

11.4.1 Description

The DRIVE-CLiQ Flanged Coupling is used to connect two DRIVE-CLiQ cables and can be installed in a cabinet wall.

A DRIVE-CLiQ connection with degree of protection IP67 is implemented at the interface outside the cabinet. Inside the cabinet, a connection with degree of protection IP20 is implemented. The interface between the cabinet wall and the DRIVE-CLiQ Flanged Coupling satisfies degree of protection IP54.

In addition to the data lines, the power supply contacts of DRIVE-CLiQ are also routed via the coupling.

11.4.2 Safety information

Caution

Only cables from Siemens must be used for DRIVE-CLiQ connections.

11.4.3 Interface Description

11.4.3.1 Overview

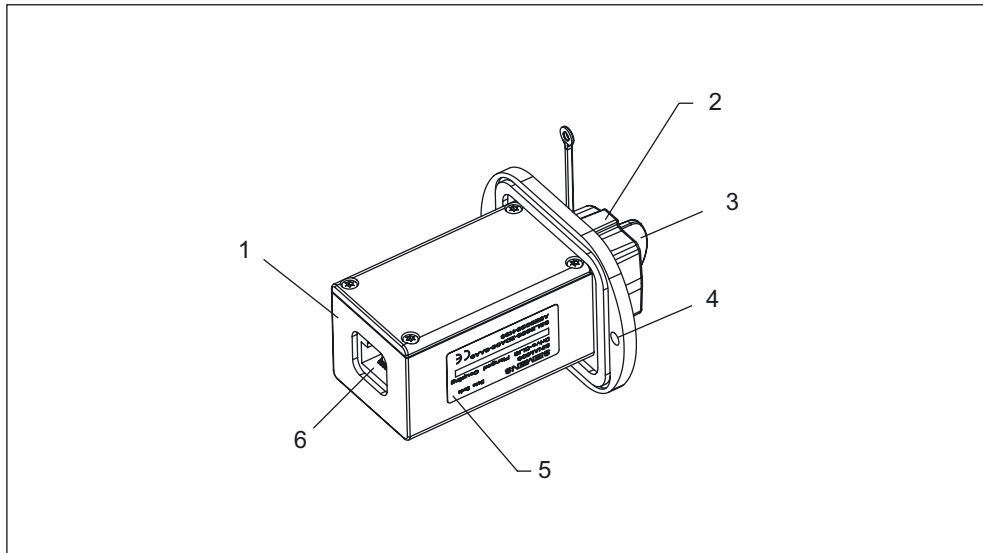

Figure 11-10 DRIVE-CLiQ Flanged Coupling

1	DRIVE-CLiQ Flanged Coupling
2	Centering cap
3	IP67 interface
4	Mounting holes
5	Type plate
6	IP20 interface

11.4.4 Dimension drawing

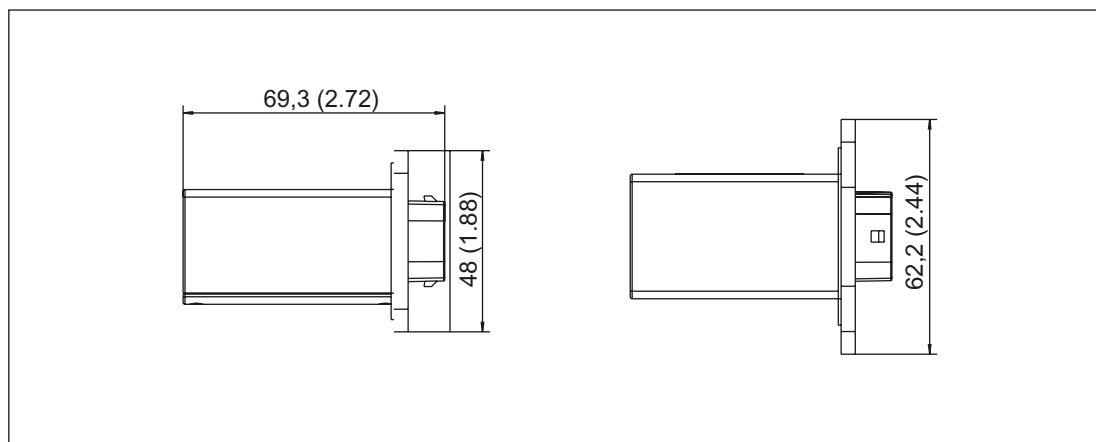

Figure 11-11 Dimension drawing of the DRIVE-CLiQ Flanged Coupling

Accessories	B [mm]	T [mm]	H [mm]
DRIVE-CLiQ Flanged Coupling (with seal)	69.3 (2.72)	62.2 (2.44)	48 (1.88)

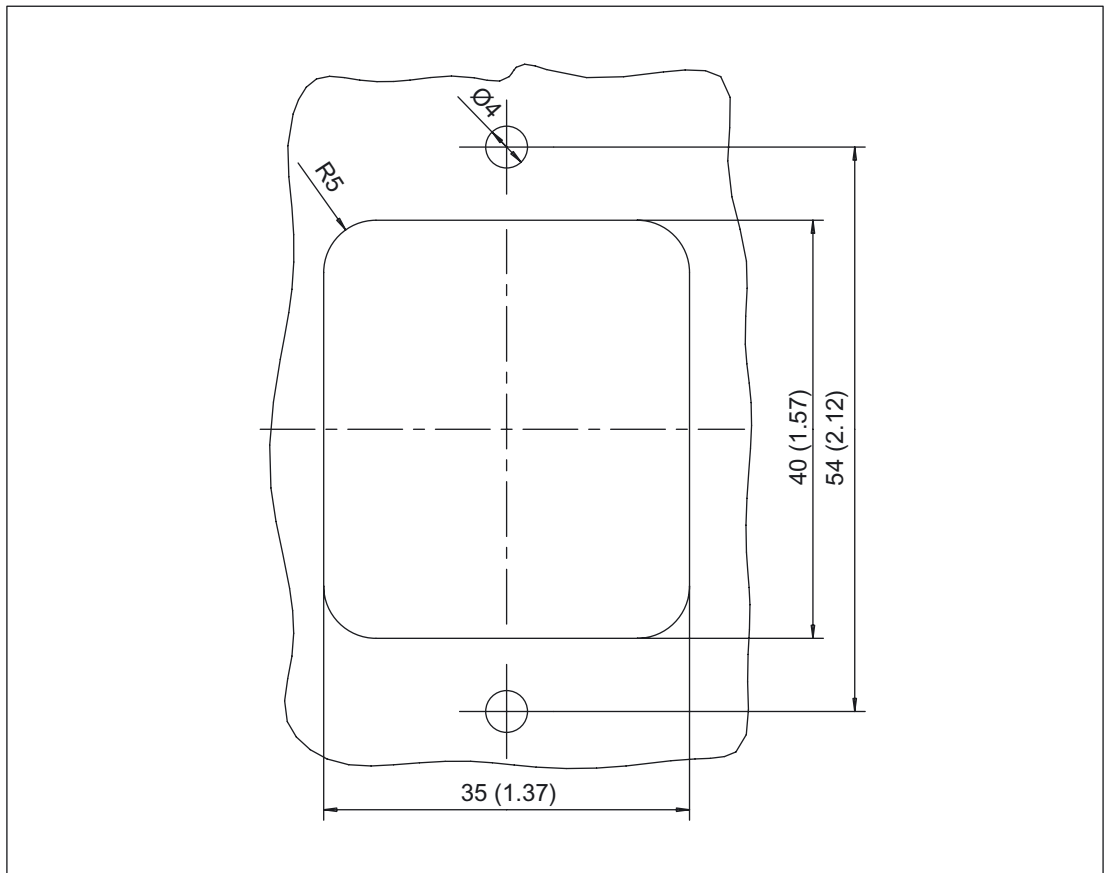

Figure 11-12 Cutout for cabinet

11.4.5 Installation

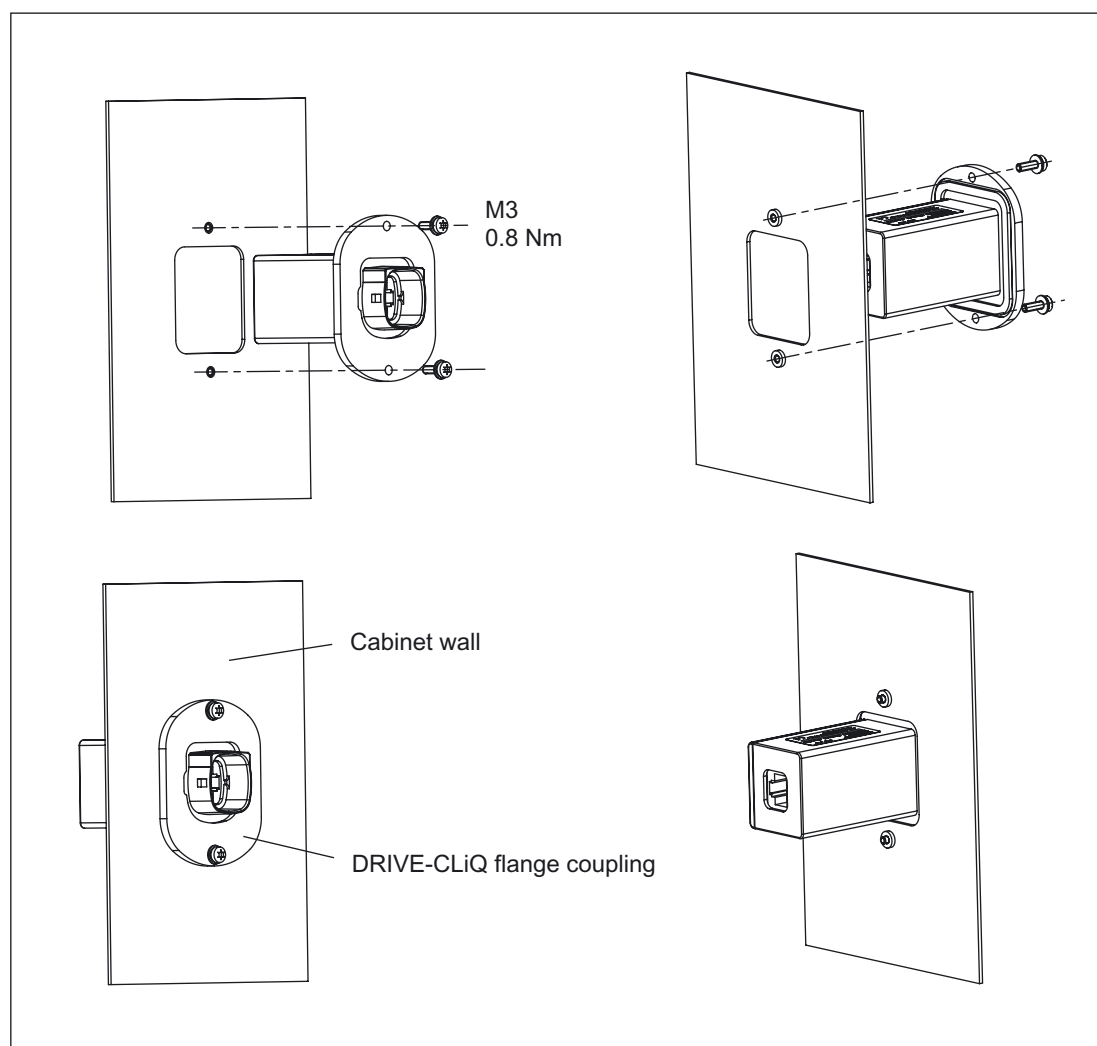

Figure 11-13 DRIVE-CLiQ Flanged Coupling

Installation

1. Create an opening for the DRIVE-CLiQ Flanged Coupling in the cabinet wall in accordance with "Dimension drawing".
2. Insert the DRIVE-CLiQ Flanged Coupling in the opening from outside the cabinet.
3. Secure the DRIVE-CLiQ Flanged Coupling to the outer cabinet wall with two bolts M3 and two nuts. In order to ensure good EMC, an electrically conductive connection should be established between the DRIVE-CLiQ Flanged Coupling and the cabinet wall.

11.4.6 Technical specifications

Table 11-16 Technical Specifications

DRIVE-CLiQ Flanged Coupling 6FX2003-0DC0x	Unit	
Weight	kg	0,135
Degree of protection	IP20 to EN 60 529 inside the cabinet IP54 to EN 60 529 outside the cabinet	

11.5 DRIVE-CLiQ Coupling

11.5.1 Description

The DRIVE-CLiQ Coupling is used to connect two DRIVE-CLiQ cables in accordance with degree of protection IP67.

In addition to the data lines, the power supply contacts of DRIVE-CLiQ are also routed via the coupling.

11.5.2 Safety information

Caution

Only cables from Siemens must be used for DRIVE-CLiQ connections.

11.5.3 Interface Description

11.5.3.1 Overview

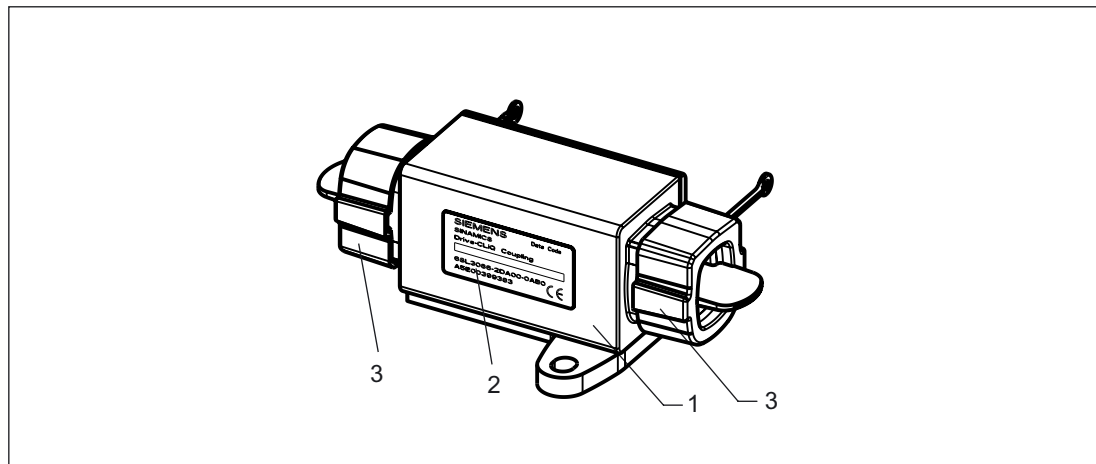

Figure 11-14 DRIVE-CLiQ Coupling

1	DRIVE-CLiQ Coupling
2	Type plate
3	Centering caps

11.5.4 Dimension drawing

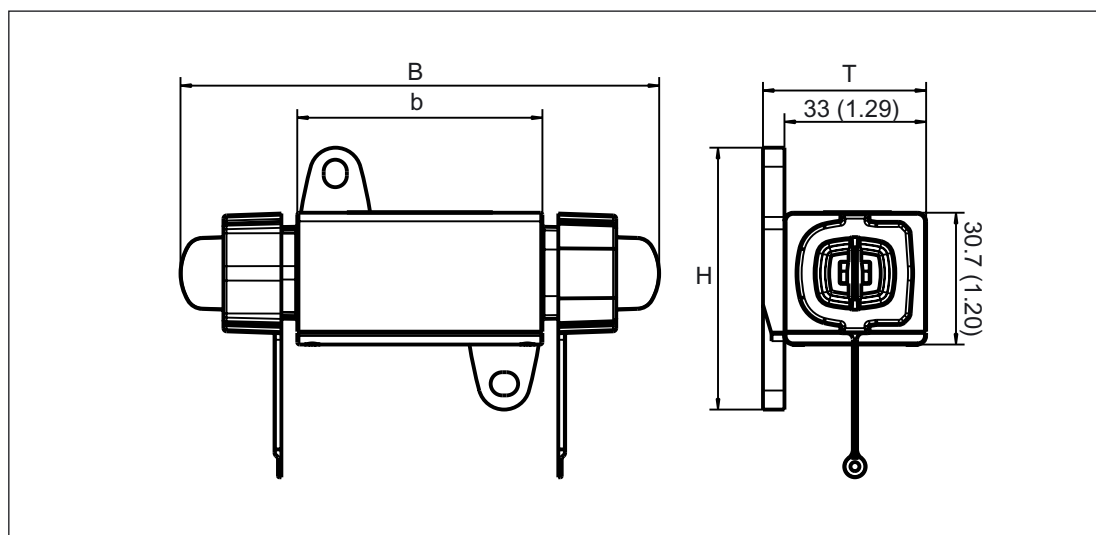

Figure 11-15 Dimension drawing of the DRIVE-CLiQ Coupling

Accessories	B [mm]	H [mm]	T [mm]
DRIVE-CLiQ Coupling	81.5 (3.20)	33 (1.29)	30.7 (1.20)

11.5.5 Installation

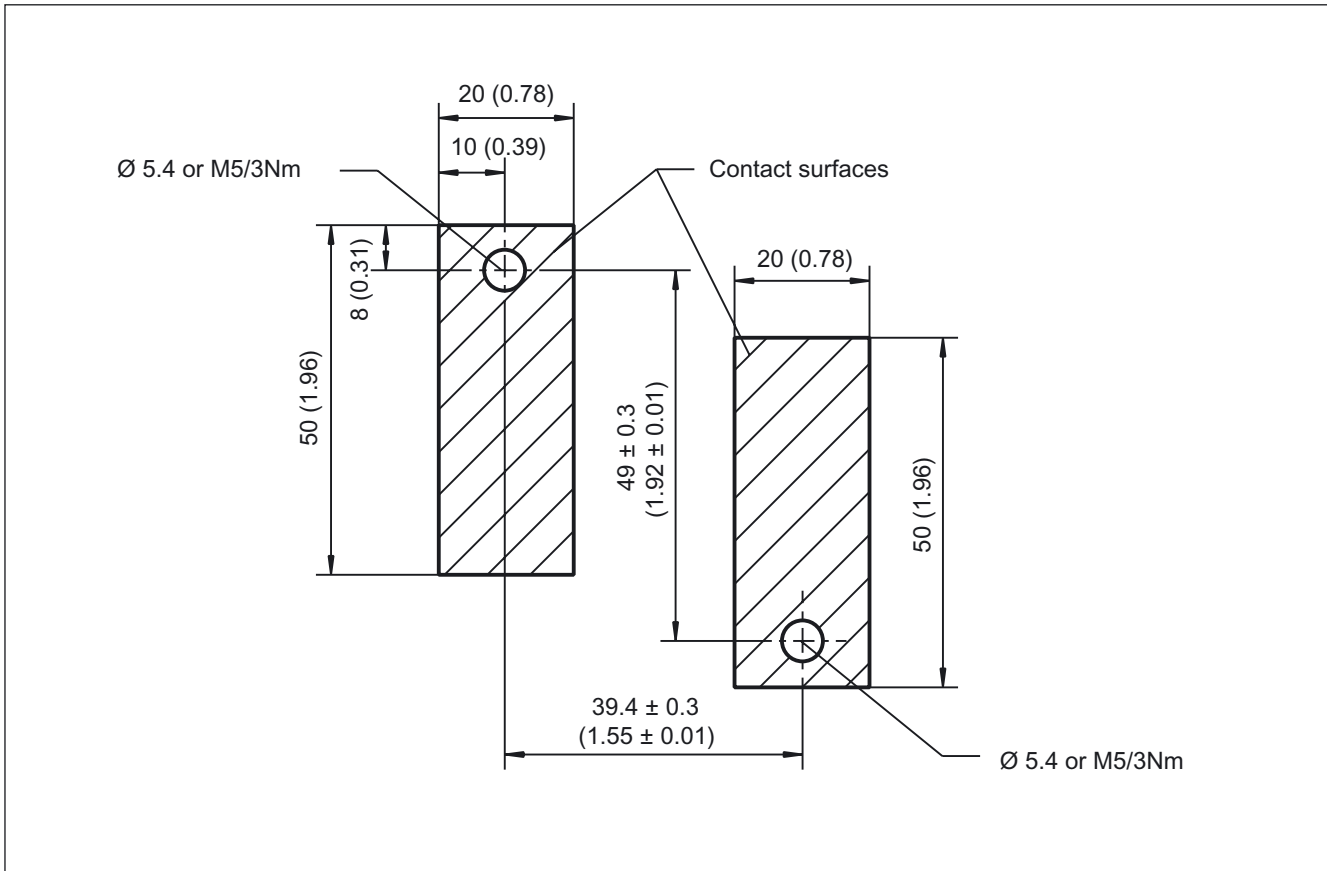

Figure 11-16 Hole drilling template for installation

1. Fit the DRIVE-CLiQ coupling in accordance with the hole drilling template on the mounting surface.
2. Remove the protective caps on the DRIVE-CLiQ coupling.
3. Plug the DRIVE-CLiQ connector into both ends of the DRIVE-CLiQ coupling.

11.5.6 Technical specifications

Table 11-17 Technical Specifications

DRIVE-CLiQ Coupling 6FX2003-0DC1x	Unit	
Weight	kg	0.14
Degree of protection	IP67-IP67	

Cabinet Design and EMC

12.1 Information

12.1.1 General

The SINAMICS S components are designed in accordance with degree of protection IP20 to EN 60529 and as open-type devices to UL 50. This ensures protection against electric shocks. To ensure protection against mechanical stress and climatic conditions too, the components should only be operated in housing/cabinets/rooms that fulfill at least degree of protection IP54 and, as enclosure types, are designed to UL 50.

Prefabricated MOTION CONNECT cables are recommended.

The Safety-Integrated safety function:

The components must be protected against conducted contamination (e.g. by installing them in a cabinet with degree of protection IP54).

Provided that conducted interference can be prevented at the installation site, the degree of protection for the cabinet can be decreased accordingly.

Low-voltage switchgear and controlgear assemblies

Part 1: Type-tested and partially type-tested low-voltage switchgear assemblies

If the SINAMICS S drive line-up is used for the electrical equipment of machines, the applicable requirements of EN 60204-1 must also be adhered to.

Safety of machinery

Electrical equipment of machines

Part 1: General requirements

All information for device selection in this section applies to

- Operation in a TN system
- Operating voltage range 360 V 3AC to 440 V 3AC

12.1.2 Safety Information



Danger

When installing the cabinet, you must cover the ventilation slots to prevent drill swarf, wire end ferrules, and so on from falling into the housing, which could result in short-circuits or damage the insulation.

Safety regulations governing shock protection must be observed. See also EN 60204-1.



Danger

Only motors with a safe electrically isolated holding brake may be connected. The brake conductors must also be safely electrically isolated.

If the motor power cable is connected to intermediate terminals, the power cables and brake cables must be routed apart (≥ 300 mm).



Warning

Cable shields and unused conductors of power cables (e.g. brake conductors) must be connected to PE potential.

Non-observance can cause lethal shock voltages.

Caution

The tightening torque of the DC link busbar screws (1.8 Nm) must be checked before startup.

To ensure that the encoder system works properly, you are advised to use the original Siemens accessories from catalogs D21.1 and D21.2.

12.1.3 Directives and Standards

The following directives and standards apply within the European Union:

Table 12-1 EC Directives

Directive	Description
73/23/EEC	Directive of the Council of February 19, 1973, on the approximation of the laws of the member states relating to electrical equipment designed for use within certain voltage limits Low-Voltage Directive
98/37/EC	Directive of the Council of August 12, 1998, on the approximation of laws of the member states relating to machinery Machine Directive
89/336/EEC	Directive of the Council on the approximation of laws of the member states relating to electromagnetic compatibility EMC Directive

Conformance with the harmonized standards is an indication of conformance with the basic requirements of these laws.

The following table lists some application-relevant standards:

Table 12-2 Standards

Standard	Description
EN 292-1	Safety of machinery General principles for design Part 1: Basic terminology, methodology
EN 292-2	Safety of machinery General principles for design Part 2: General requirements
EN 418	Safety of machinery Emergency stop equipment Functional aspects; principles for design
EN 563	Safety of machinery Temperatures of touchable surfaces Ergonomics data to establish temperature limit values for hot surfaces
EN 894-1	Safety of machinery Ergonomic requirements for the design of displays and control actuators Part 1: General principles for human interactions with displays and control actuators
EN 894-2	Safety of machinery Ergonomic requirements for the design of displays and control actuators Part 2: Displays
EN 954-1 and BGL. 1	Safety of machinery General principles for design Part 1: Safety-related parts of control systems and supplement 1

12.1 Information

Standard	Description
EN 1037	Safety of machinery Prevention of unexpected startup
EN 1050	Safety of machinery Principles for risk assessment
EN 1921	Safety of integrated manufacturing systems
EN 12417	Safety of machine tools Machining centres
EN 50178	Electronic equipment for use in power installations
EN 60073	Basic and safety principles for man-machine interface, marking and identification – Coding principles for indicators and actuators
EN 60204-1	Safety of machinery Electrical equipment of machines Part 1: General requirements
EN 60417-1	Graphical symbols for use on equipment Part 1: Overview and application
EN 60417-2	Graphical symbols for use on equipment Part 2: Symbol originals
EN 60439-1	Low-voltage switchgear and controlgear assemblies Part 1: Type-tested and partially type-tested assemblies
EN 60446	Basic and safety principles for man-machine interface, Identification of conductors by colours or numerals
EN 60447	Man-machine interface Actuating principles
EN 60529	Degrees of protection provided by enclosures (IP code)
EN 60695-1-1	Fire hazard testing Part 1-1: Guidance for assessing the fire hazard of electrotechnical products General guidelines
EN 61000-6-2	Electromagnetic compatibility (EMC) Generic standards: Immunity for industrial environments
EN 61000-6-4	Electromagnetic compatibility (EMC) Generic standards: Emission standard for industrial environments
EN 61310-1	Safety of machinery – Indication, marking and actuating Part 1: Requirements for visual, auditory and tactile signals
EN 61310-2	Safety of machinery – Indication, marking and actuating Part 2: Requirements for marking
EN 61310-3	Safety of machinery – Indication, marking and actuating Part 3: Requirements for the location and operation of actuators
EN 61800-3	Adjustable speed electrical power drive systems Part 3: EMC product standard including specific test methods
UL 508A	Industrial control panels
UL 508C	Industrial Control Equipment Standard for safety for power conversion equipment

12.2 Selection of Devices Required for Operating SINAMICS

12.2.1 General

Connection to the power supply network required:

- Line isolating device
- Line fuse
- Line contactor
- Line filter (see Chapter "Line connection")
- Line reactor (see Chapter "Line connection")

12.2.2 Information About Line Disconnecting Devices

The line isolating device for the electrical equipment may be used for correct isolation of the drive line-up from the power supply. This line isolation device must be for electrical equipment of machinery in conformance with the requirements of EN 60204-1, Section 5.3. The relevant technical specifications must be taken into account in selection. Further loads of the electrical equipment must be included in the selection where applicable.

The line isolation device must be fitted with a leading opening control switch ($t = 10$ ms, that must be included in the opening of connections X21:3 (EP +24 V) and X21:4 (EP GND) for Active Line Modules.

The necessary accessories for line isolation devices must be selected from manufacturer catalogs.

12.2.3 Overcurrent Protection by Means of Line Fuses or Circuit-Breakers

The cables for the drive line-up power supply must be protected against overcurrent. LV HBC, D-type, and DO-type fuses with a gL characteristic or suitable circuit-breakers can be used.

Note

For use in networks capable of supplying a maximum of 36 kA rms at 480 Vac if the device is protected by means of the UL-approved (JFHR2) semiconductor safety fuse specified in the manual.

The devices have to be protected with semiconductor fuses in accordance with the Manual.

The following tables list the requirements regarding line fuses and circuit-breakers for the Active Line Modules and Smart Line Modules.

Table 12-3 Requirements regarding line fuses and circuit-breakers for the Active Line Modules

	16 kW	36 kW	55 kW	80 kW	120 kW
$I_{rated\ fuse}$	35 A	80 A	125 A	160 A	250 A
$I_{fuse\ 0.2s}$	>180 A	>360 A	>450 A	>650 A	>865 A
$I_{fuse\ 4s}$	>130 A	>260 A	>350 A	>505 A	>675 A
$I_{fuse\ 10\ s}$	>100 A	>200 A	>250 A	>360 A	>480 A
$I_{fuse\ 240\ s}$	>60 A	>135 A	>200 A	>280 A	>380 A

Table 12-4 Requirements regarding line fuses and circuit-breakers for the Smart Line Modules

	5 kW	10 kW	16 kW	36 kW
$I_{rated\ fuse}$	16 A	35 A	35 A	80 A
$I_{fuse\ 0.2s}$	>70 A	>100 A	>180 A	>360 A
$I_{fuse\ 4s}$	>50 A	>80 A	>130 A	>260 A
$I_{fuse\ 10\ s}$	>42 A	>65 A	>100 A	>200 A
$I_{fuse\ 240\ s}$	>30 A	>45 A	>60 A	>135 A

See catalog D21.2

12.2.4 Line Contactors

The line contactor is required for electrical isolation of the DC link of the drive line-up from the power supply network.

For selection of the line contactor, the characteristic values in the technical specifications apply. The cable routing, the bundling factor, and the factor for the ambient temperature according to EN 60204-1 is taken into account in rating the conductors to be connected.



Caution

The line filter must not be switched under load.

When using the digital output to control the line contactor, the make/break capacity must be taken into account. The coil power is stated for that purpose.

We recommend connecting the contactor coils with suitable varistors to limit the opening overvoltage.

12.3 24 V DC Supply Voltage

12.3.1 General

The 24 V DC voltage is required for the power supply of:

1. The electronics of the SINAMICS components via the integrated 24 V busbar
2. The electronics of the Control Units, Option Boards, Sensor Modules, and Terminal Modules, as well as the process voltage of their digital inputs
3. The load voltage of the digital outputs
4. The motor holding brakes

A separate 24 V supply is recommended for a drive line-up.

Notice

If other consumers are connected to the power supply, connected inductance devices (contactors, relays) must be fitted with suitable overvoltage protection circuits.

Notice

The tolerances of the motor holding brakes and the voltage drops of the connection cables must be taken into account. The electronics power supply may have to be increased.



Danger

Only motors with a safe electrically isolated holding brake may be connected. The brake conductors must also be safely electrically isolated.

If the motor power cable is connected to intermediate terminals, the power cables and brake cables must be routed apart (≥ 300 mm).



Danger

Only protective extra-low voltages (PELVs) that comply with EN60204-1 must be connected to the connections and terminals between 0 and 48 V DC.

The voltage tolerances of the motor holding brakes must be taken into account.

Note

A regulated DC power supply is required to operate motors with a built-in holding brake. The voltage is supplied via the internal 24 V busbars. The voltage tolerances of the motor holding brakes and the voltage drops of the connection cables must be taken into account.

The DC power supply should be set to 26 V. The CSM supplies 26 V. This ensures that the supply voltage for the brake remains within the permissible range when the following conditions are fulfilled:

- Using Siemens three-phase motors
- Using Siemens MOTION-CONNECT power cables
- Motor cable lengths: max. 100 m

12.3.2 Selecting Power Supply Units

You are advised to use the devices in the following table. These devices meet the requirements of EN 60204-1.

Table 12-5 Recommended SITOP Power

Rated output current [A]	Input voltage range [V]	Short-circuit current [A]
5	2AC 85-132/170 – 550	5.5
10	2AC 85-132/176 – 550	30 for 25 ms
20	3AC 320 – 550	23
40	3AC 320 – 550	46

Table 12-6 Recommendation for control supply module

Rated output current [A]	Input voltage range [V]	Short-circuit current [A]
20	3AC 380 -10% to 3AC 480 +10% (-15% < 1 min) DC 300 – 800	< 24

See catalog D21.2.

12.3.3 Typical 24 V Component Current Consumption

The following table can be used to calculate the 24 V DC power supply.

Table 12-7 Overview: 24 V DC current consumption with cold-plate cooling

Component	Current consumption [A _{dc}]
CU320 without load	0,8
per digital output	max. 0.5 (typ. 0.4)
PROFIBUS Teleservice	max. 0.15
TB30 (without digital outputs)	< 0.05
per digital output	max. 0.5 (typ. 0.1)
CBC10	0.05
Active Line Modules	
16 kW	0.8
36 kW	1.0
55 kW	1.4
80 kW	2
120 kW	2.5
Smart Line Modules	
5 kW	0.65
10 kW	0.7
DRIVE-CLiQ and brake	
DRIVE-CLiQ (e.g. motors with DRIVE-CLiQ interface)	Typ. 0.25, max. 0.45
Brake (e.g. motor holding brake)	Typ. 0.4 to 1.1; max. 2
Single Motor Modules	
3 A (+1 x DRIVE-CLiQ; +1 x brake)	0.6
5 A (+1 x DRIVE-CLiQ; +1 x brake)	0.6
9 A (+1 x DRIVE-CLiQ; +1 x brake)	0.6
18 A (+1 x DRIVE-CLiQ; +1 x brake)	0.6
30 A (+1 x DRIVE-CLiQ; +1 x brake)	0.6
60 A (+1 x DRIVE-CLiQ; +1 x brake)	0.7
85 A (+1 x DRIVE-CLiQ; +1 x brake)	1.0
132 A (+1 x DRIVE-CLiQ; +1 x brake)	1.5
200 A (+1 x DRIVE-CLiQ + 1 x brake)	1.5
Double Motor Modules	
2 x 3 A (+2 x DRIVE-CLiQ; +2 x brake)	0.85
2 x 5 A (+2 x DRIVE-CLiQ; +2 x brake)	0.85
2 x 9 A (+2 x DRIVE-CLiQ; +2 x brake)	0.85
2 x 18 A (+2 x DRIVE-CLiQ; +2 x brake)	0.95
Braking Module	0.5

Component	Current consumption [A _{DC}]
Sensor Modules	
SMC10	typ. 0.25
SMC20	typ. 0.25
SMC30	typ. 0.33
Additional system components	
TM31 (without digital outputs) per digital output	typ. 0.12 max. 0.5 (typ.0.1)

12.3.4 Overcurrent Protection

Cables on both the primary and the secondary side of the power supply unit must be protected from overcurrent. Primary side protection must be implemented according to the manufacturer's instructions. Secondary side protection must be rated to deal with the actual conditions. In particular:

- Loading due to loads, possibly the simultaneity factor in response to machine operation
- Current carrying capacity of the conductors used and cables in normal and short-circuit conditions
- Ambient temperature
- Bundling of the cables in a one duct
- Cable laying method to EN 60204-1

EN 60204-1, Section 14, can be used to determine the overcurrent protection devices.

The recommended overcurrent protection devices on the primary side are circuit-breakers as specified in Siemens catalog NSK. Miniature circuit-breakers are recommended as overcurrent protection devices on the secondary side. The MCBs can be selected according to Siemens catalog "BETA Modular Installation Devices - ET B1".

The 24 V DC supply for the following booksize components:

- Line Modules
- Motor Modules
- Braking Modules
- Capacitor Modules
- Control Supply Modules

is implemented in the components by means of a 24 V busbar for 24 V DC and reference potential. The current carrying capacity of these bars is 20 A. The power supply is connected via a 24 V terminal adapter. MCBs are recommended to protect the cables from overcurrent. These overcurrent protection devices also protect the 24 V busbars. To protect against ground faults, the ground potential must be connected to the protective conductor system.

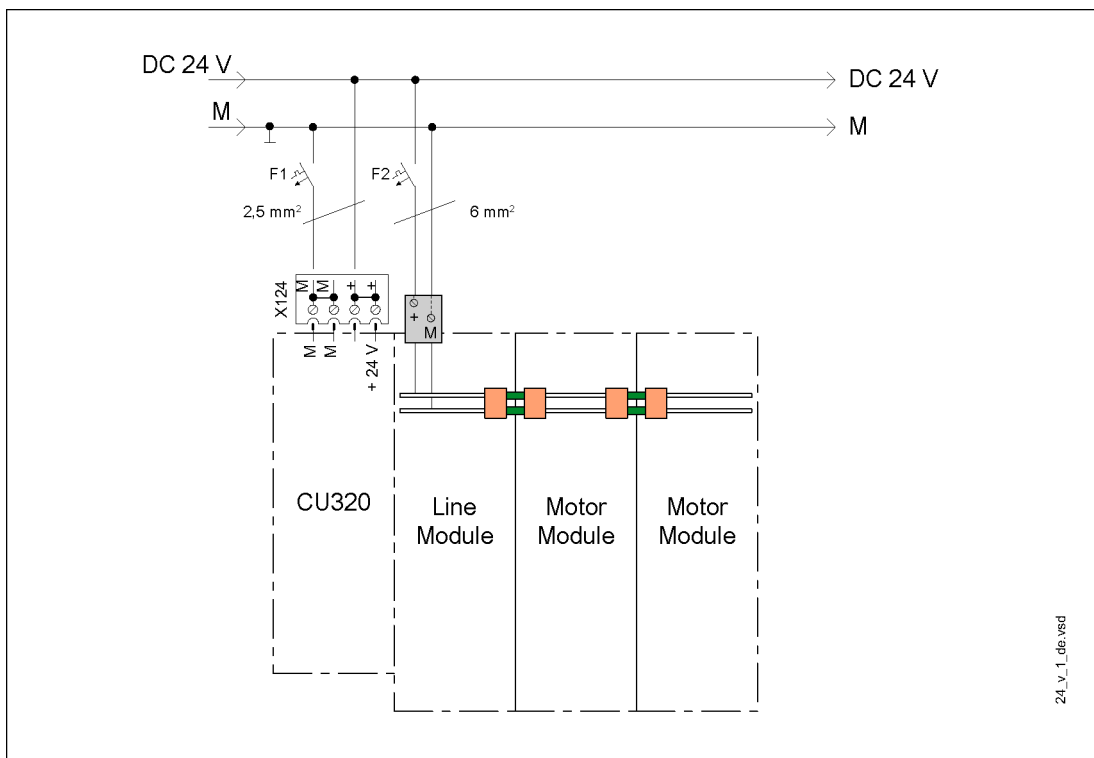

Figure 12-1 Example of 24 V DC fuse protection

The following conditions apply to the cables when the MCBs are selected from the following table:

- Ambient temperature 40 °C or 55 °C
- Max. 1 conductor pair, bundled
- Conductor limit temperature 70 °C for normal operation
- Cable length max.:
 - 10 m for the supply cables
 - 30 m for signal lines
- To be routed separately from other cables and conductors carrying operating current.
- Cable type: PVC conductor cable

Table 12-8 MCBs by conductor cross-section and temperature

Conductor cross-section	Max. value up to 40 °C	Max. value up to 55 °C
1.5 mm ²	10 A	10 A
2.5 mm ²	20 A	10 A
4 mm ²	25 A	16 A
6 mm ²	32 A	25 A
24 V busbar	20 A	20 A

The trip characteristic of the MCBs must be selected to match the loads to be protected and the max. current provided by the power supply unit in the event of a short-circuit.

Example: calculating the 24 V DC current requirements with cold-plate cooling

Table 12-9 Example: 24 V DC current requirements with cold-plate cooling

Component	Number	Current consumption [A]	Total current consumption [A]
CU320	1	0.4	0.4
8 digital outputs	8	0.1	0.8
Active Line Module 36 kW	1	1.0	1.0
Motor Module 18 A	2	0.6	1.2
Motor Module 30 A	3	0.6	1.8
SMC20	10	0.25	2.5
Brake	5	1.1	5.5
Total:			13.2

12.4 Arrangement of Components and Equipment

12.4.1 General

The arrangement of the components and equipment takes account of

- Space requirements
- Cable routing
- Heat dissipation
- EMC

Components are usually located centrally in a cabinet.

12.4.2 Drive Line-Up

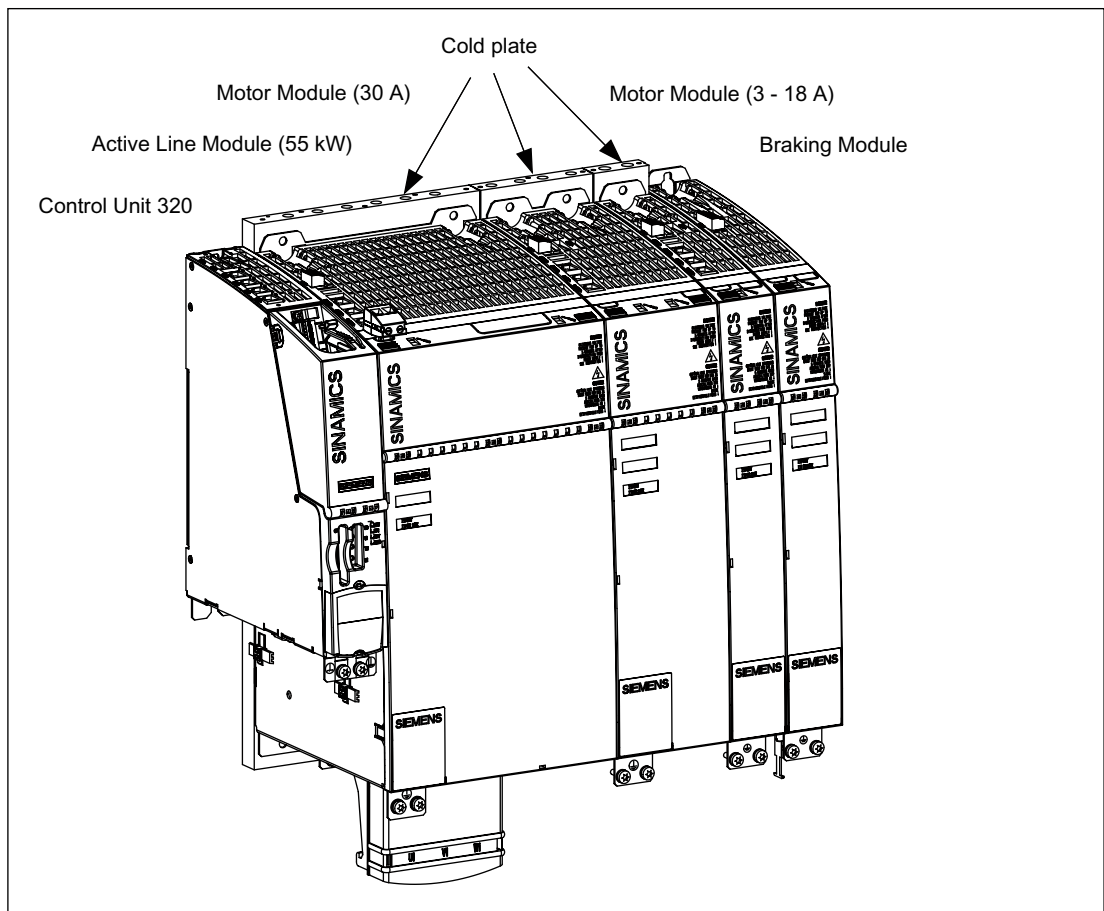

Figure 12-2 Example of a drive line-up

The components in the drive line-up must be properly connected to the external heat sink.

The components can be arranged in one or more tiers. In a multiple-tier arrangement, vertical installation or, in a cabinet row, side-by-side installation in different cabinet sections is possible.

To determine the cross-section, use the DC link busbar current carrying capacity given in the relevant technical specifications.

Multiple-tier configuration



Figure 12-3 Removing the DC link bridges (multi-tier configuration)

The DC link bridges must be removed by unscrewing the M4 screws.



Danger

When the infeed is on the right-hand side of the drive line-up, the DC link bridges on the left-hand module of the drive line-up must be removed.

Continuation of the DC link with the DC link adapter external to the components is achieved using single-core, finely-stranded and shielded cables that are laid so as to ensure they are short-circuit and ground-fault proof.

Two-tier configuration

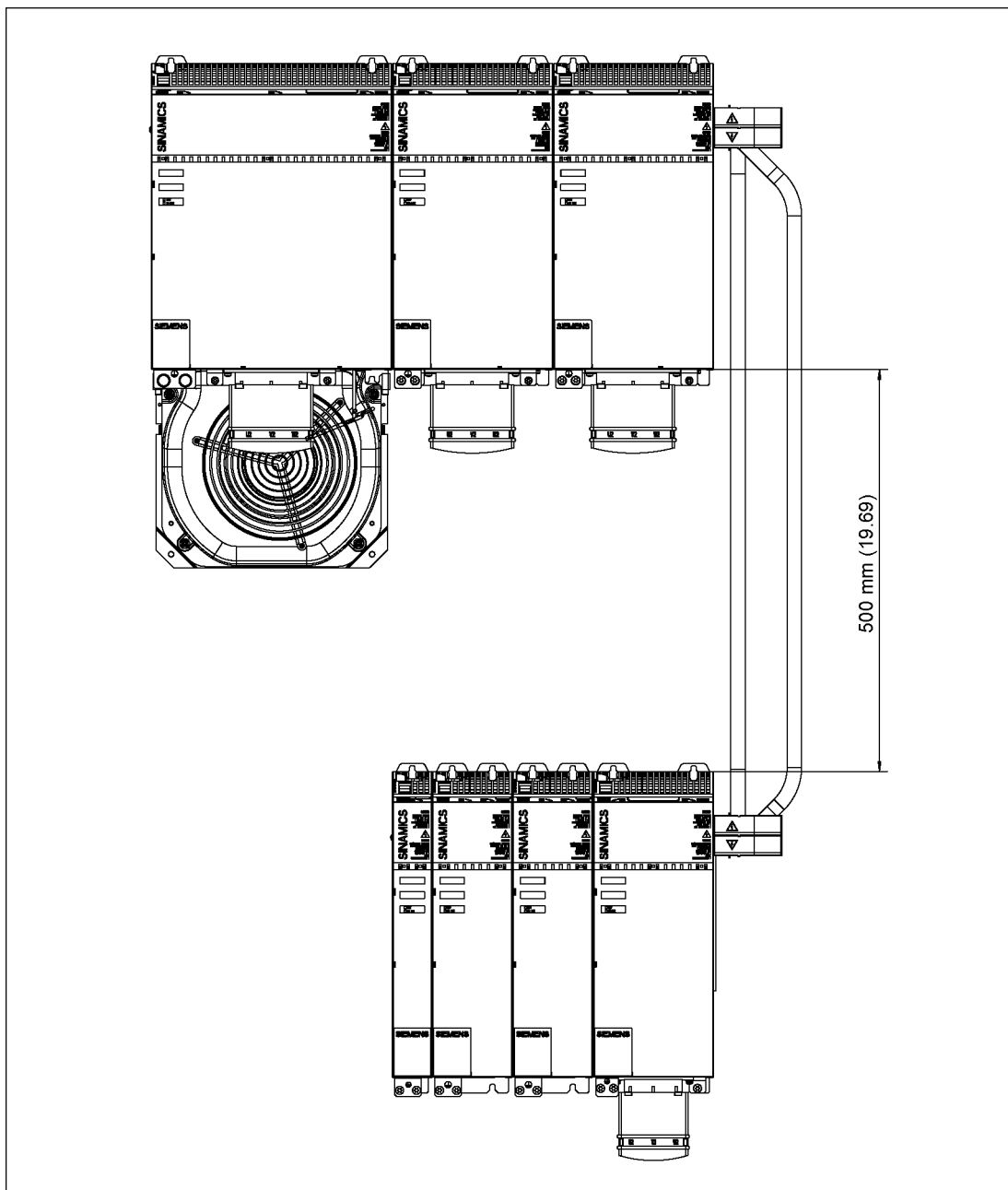

Figure 12-4 Example of a multi-tier configuration with modules between 200 and 300 mm wide

The distance between the two module rows depends on the wiring and cable cross-section.

For modules with a width of between 50 and 100 mm, the distance between the upper and lower module row must be at least 300 mm.

For modules with a width of between 150 and 300 mm, the distance between the upper and lower module row must be at least 500 mm (see Cooling).

Caution

Signal cables must not be routed parallel to power cables.

Overview of the DC link supply adapter and DC link adapter

	Suitable for module width:	Max. connectable cross-section	Max. current carrying capacity
DC link supply adapter (cable outlet on top)			
6SL3162-2BD00-0AAx	50 mm, 100 mm	10 mm ²	36 A
6SL3162-2BM00-0AAx	150 mm, 200 mm, 300 mm	95 mm ²	240 A
DC link adapter (cable outlet on side)			
6SL3162-2BM01-0AAx	all	95 mm ²	240 A

Note

The current carrying capacity of the DC link busbars must be taken into account. For the specifications, see the technical specifications for the module.

12.4.3 Three-tier configuration

Multiple-tier configuration

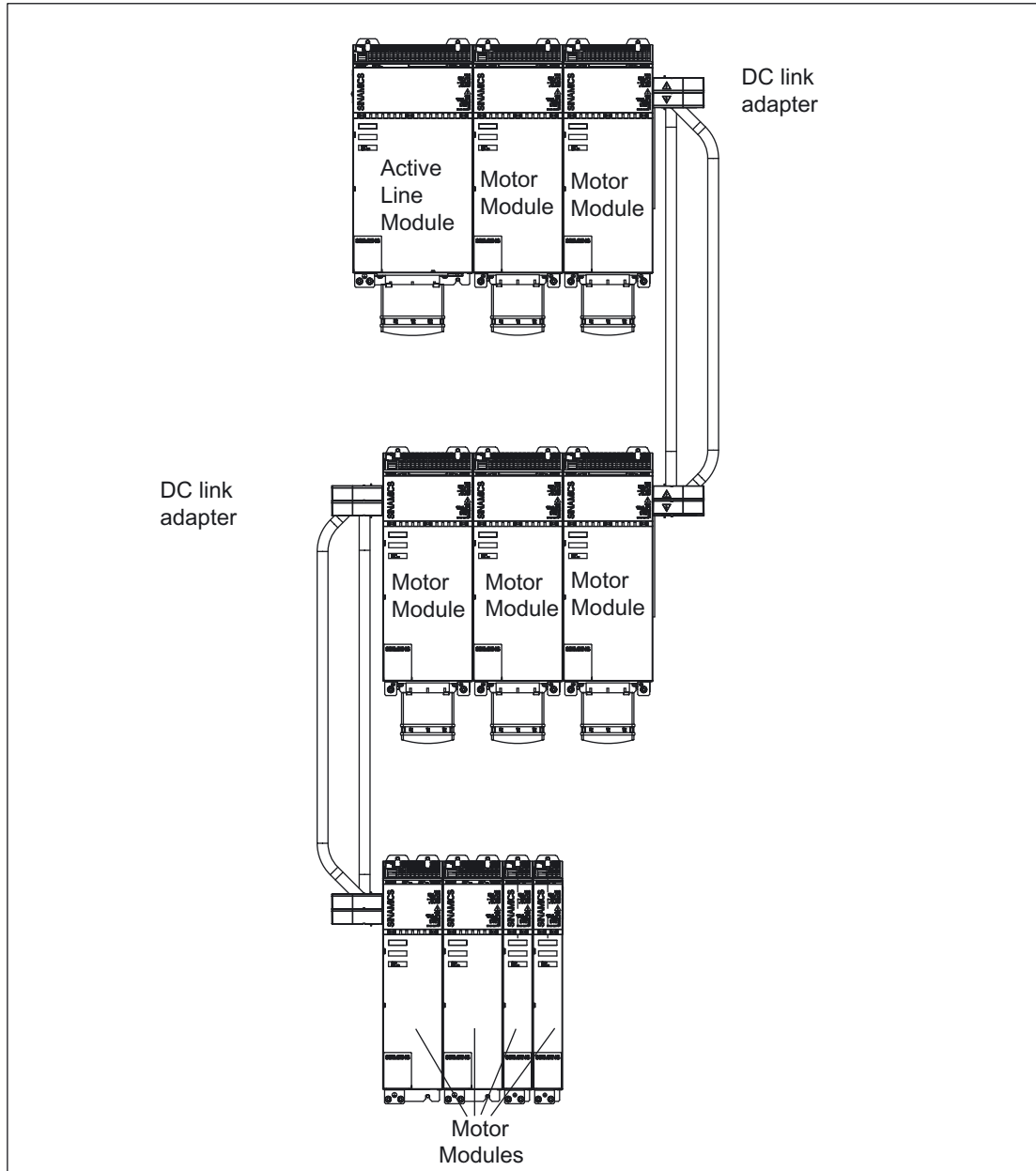

Figure 12-5 Example of a three-tier configuration with modules between 50 and 200 mm wide

Note

When the power supply input is on the right-hand side of the drive line-up (e.g. in a multiple-tier configuration), the above rules apply in reverse.

This means that the Motor Modules are arranged in order of power from the highest power to the lowest power followed by the DC link components, such as the Braking Module.

In the case of Active Line Modules as of 55 kW, the Motor Modules can be mounted on the right or left (see "DC link adapter").

12.4.4 Connecting the Cooling Water

Cooling system/circuit requirements

Caution

You must take great care when laying the water pipes. The pipes must be secure and checked for leaks. The water cables must never come into contact with live parts.

- The components for connecting the water to the equipment are made of stainless steel or thick aluminum. A G 1/2" internal thread is provided for the water connection. The connection is flat sealing.
- The cooling water infeed line (blue) and return line (red) must be connected in accordance with their color markings. The color markings are located next to the water connection.
- Open cooling systems must never be used. Only closed cooling systems - preferably with a mechanism for monitoring the quality of the cooling water - must be installed.
- The electrochemical processes that take place in a cooling system must be minimized by choosing the right materials. For this reason, mixed installations (i.e. a combination of different materials, such as copper, brass, iron, or halogenated plastic (PVC hoses and seals)) should not be used.
- Stainless steel (V2A or V4A steel; NIROSTA austenite) and non-conductive EPDM/NBR hoses (EPDM on the water side) are recommended for the cooling system piping.
- Equipotential bonding between the components in the cooling system (converter, heat exchanger, piping, pump, etc.) must be ensured using conductive construction elements with a copper bar or stranded copper with the appropriate conductor cross-sections.
- Requirements regarding the quality of the cooling water must also be observed.
- Corrosion inhibitor must be added to the cooling water.

Commissioning

Caution

The system must only be vented once it has been disconnected from the power supply.

- When the equipment is filled for the first time, the heat sinks must be vented.
- Remove the safety seal screws in front of the vent valve.
- Vent the system.
- Close the vent valve.
- Replace the safety seal screws.
- Ensure that they are tight.
- The operating pressure must be set in accordance with the flow conditions of the cooling water network in the infeed and return line.
- The required cooling quantity per time unit must be set.

12.5 Electromagnetic Compatibility

12.5.1 General

EMC requirements can be found in EN 60439-1 and recommendations in EN 60204-1. For installation of components in cabinets, the following conditions must be ensured to comply with the EMC Directive:

- Operation in TN systems with SINAMICS line filters
- Observance of information about cable shielding and equipotential bonding
- Use of recommended Siemens power and signal cables.
- Only Siemens cables may be used for DRIVE-CLiQ connections.

For MOTION-CONNECT cables please refer to Catalog D21.1 or D21.2.

Caution

No couplings or self-made cables may be used for the DRIVE-CLiQ connections.

12.5.2 Cable Shielding and Routing

In order to comply with the EMC requirements, certain cables must be routed apart from other cables and from certain components. To full EMC requirements, the following cables must be used with shields:

- Power supply cables from line filter via line reactor to Line Module
- All motor cables (if necessary, including cables for motor holding brake)
- Cables for "fast inputs" of the Control Unit
- Cables for analog direct voltage/current signals
- Signal cables for sensors
- Cables for temperature sensors

The EMC measures described above ensure CE compliance with the EMC Directive. Alternative measures (e.g. routing behind mounting plates, suitable clearances) can also be used provided they have similar results. This excludes measures that relate to the design, installation, and routing of motor power cables and signal cables. If unshielded cables are used between the line connection point and line filter, make sure that no interfering cables are routed in parallel.

The cable shields must be connected as close to the conductor terminal connections as possible to ensure a low-impedance connection with cabinet ground. For Siemens power cables in which the shield is connected to the connector shell (see relevant catalog), this is a sufficiently good shield contact.

With components that do not have any special shield connection or where the shield connection is not sufficient, the cable shields can be connected to the metal mounting plate using hose clamps and toothed rails. The cable length between the shield contact point and the terminals for cable conductors must be kept as short as possible.

Shield contact plates with pre-prepared clip contacts are available for contacting the shields for power cables of Line Modules and Motor Modules. Up to a module width of 100 mm, these plates are part of the scope of supply of the components, or they are integrated in the connector.

All cables inside the cabinet must be connected as closely as possible to parts connected with cabinet ground, such as a mounting plate or cabinet wall. Ducts made of sheet steel or routing cables between steel sheets (e.g. between the mounting plate and back wall) should provide adequate shielding.

Avoid, where possible, routing unshielded cables, connected to the drive line-up, in the immediate vicinity of noise sources, e.g. transformers. Signal lines (shielded and unshielded) connected to the drive line-up, must be routed as far as possible away from strong external magnetic fields (e.g. transformers, line reactors). In both cases, a distance of ≥ 300 mm is usually sufficient.

Signal and DC power supply cables

Operating unshielded signal and direct current supply cables (e.g. 24 V infeed with external supply):

- Direct current supply cables: Max. permissible length: 10 m
- Unshielded signal cables: Max. permissible length: 30 m (without additional wiring)

For greater lengths, suitable wiring must be connected by the user to provide overvoltage protection. For example:

Table 12-10 Recommendations for overvoltage protection

DC supply	24 V signal cables
Weidmüller Type no.: PU DS 24V 16A	Weidmüller Type no.: MCZ OVP TAZ
Weidmüller GmbH & Co. KG An der Talle 89 33102 Paderborn Tel. 05252/960-0 Fax 05252/960-116 http://www.weidmueller.com	

Caution

The connected signal and power cables must not cover the ventilation slots.

Caution

Unshielded signal cables must not be routed parallel to power cables.

Table 12-11 Maximum cable lengths

Type	Maximum length [m]
24 V DC power cables ²	10
24 V signal cables ²	30
DC link, including extensions	10
Total length of the power cables in the drive line-up comprising: motor power cables, DC link cable(s), and the power supply cable from the line filter output	350 (shielded) 560 (unshielded)
Total length: motor cables, power supply cable from the Basic Line Filter to the Active Line Module	< 150
Total cable length with VCM	630 (shielded) 850 (unshielded)
Power cable between line filter and line reactor	10 (shielded/unshielded) ¹
Power cable between line reactor and Line Module	10 (shielded/unshielded) ¹
Power cable between Motor Module and motor ≤ 18 A	70 (shielded) 100 (unshielded)
Power cable between Motor Module and motor ≤ 30 A	50 (shielded) 75 (unshielded)
Power cable between Motor Module and motor ≤ 45 A	100 (shielded) 150 (unshielded)
DRIVE-CLiQ signal cables MC500	100
DRIVE-CLiQ signal cables MC800	50
DRIVE-CLiQ signal cables FIX	100
Cable between the Braking Module and braking resistor	10

¹ To comply with EMC limit values, shielded cables (preferably Motion Connect cables) must be used.

² For greater lengths, suitable wiring must be connected by the user to provide overvoltage protection.

12.5.3 Equipotential Bonding

The SINAMICS S booksize drive system is designed for use in cabinets with a PE conductor connection.

If the drive line-up is arranged on a common unpainted metal-surfaced mounting plate, e.g. with a galvanized surface, no additional equipotential bonding is needed within the drive line-up as

- All parts of the switchgear assembly are connected to the protective conductor system.
- The mounting plate is connected with the external PE conductor by means of a finely-stranded copper conductor with a cross-section of 16 mm², including the outer conductor. As of a cross-section of 25 mm² copper, the outer cross-section of the finely-stranded conductor is halved.

For other installation methods, equipotential bonding must be implemented using conductor cross-sections as stated in the second item in the list or at least equal to the conductance.

If components are mounted on DIN rails, the data listed in the second item applies for equipotential bonding. If only smaller connection cross-sections are permissible on components, the largest must be used (e.g. 6 mm² for TM31 and SMC). These requirements also apply to distributed components located outside the cabinet.

Equipotential bonding must also be provided for the back wall. If, for example, the PROFIBUS or DRIVE-CLiQ cable is routed through several cabinets, the control unit interface "PROFIBUS equipotential bonding conductor connection" must be used for connecting the equipotential bonding conductor. A finely stranded copper conductor with a 4 mm² cross-section must be used. This conductor must be routed together with the PROFIBUS cable.

12.6 Connection methods

12.6.1 Spring-Loaded Terminals/Screw Terminals

Connectable conductor cross-sections of spring-loaded terminals

Table 12-12 Spring-loaded terminals

Spring-loaded terminal type			
1	Connectable conductor cross-sections	Flexible With wire end ferrule, without plastic sleeve With wire end ferrule, with plastic sleeve	0.14 mm ² to 1.5 mm ² 0.25 mm ² to 1.5 mm ² 0.25 mm ² to 0.5 mm ²
	Insulation stripping length	7 mm	
	Tool	Screwdriver 0.4 x 2.0 mm	
2	Connectable conductor cross-sections	Flexible	0.08 mm ² to 2.5 mm ²
	Insulation stripping length	8 to 9 mm	
	Tool	Screwdriver 0.4 x 2.0 mm	

Connectable conductor cross-sections of screw terminals

Table 12-13 Screw terminals

Screw terminal type			
1	Connectable conductor cross-sections	Flexible With wire end ferrule, without plastic sleeve With wire end ferrule, with plastic sleeve	0.14 mm ² to 1.5 mm ² 0.25 mm ² to 1.5 mm ² 0.25 mm ² to 0.5 mm ²
	Insulation stripping length	7 mm	
	Tool	Screwdriver 0.4 x 2.0 mm	
	Tightening torque	0.22 to 0.25 Nm	
2	Connectable conductor cross-sections	Flexible With wire end ferrule, without plastic sleeve With wire end ferrule, with plastic sleeve	0.2 mm ² to 2.5 mm ² 0.25 mm ² to 1 mm ² 0.5 mm ² to 1 mm ²
	Insulation stripping length	7 mm	
	Tool	Screwdriver 0.6 x 3.5 mm	
	Tightening torque	0.5 to 0.6 Nm	
3	Connectable conductor cross-sections	Flexible With wire end ferrule, without plastic sleeve With wire end ferrule, with plastic sleeve	0.2 mm ² to 2.5 mm ² 0.25 mm ² to 1 mm ² 0.25 mm ² to 1 mm ²
	Insulation stripping length	9 mm	
	Tool	Screwdriver 0.6 x 3.5 mm	
	Tightening torque	0.5 to 0.6 Nm	

12.6 Connection methods

Screw terminal type			
4	Connectable conductor cross-sections	Flexible With wire end ferrule, without plastic sleeve With wire end ferrule, with plastic sleeve	0.2 mm ² to 4 mm ² 0.25 mm ² to 4 mm ² 0.25 mm ² to 4 mm ²
	Insulation stripping length	7 mm	
	Tool	Screwdriver 0.6 x 3.5 mm	
	Tightening torque	0.5 to 0.6 Nm	
5	Connectable conductor cross-sections	Flexible With wire end ferrule, without plastic sleeve With wire end ferrule, with plastic sleeve	0.5 mm ² to 6 mm ² 0.5 mm ² to 6 mm ² 0.5 mm ² to 6 mm ²
	Insulation stripping length	12 mm	
	Tool	Screwdriver 1.0 x 4.0 mm	
	Tightening torque	1.2 to 1.5 Nm	
6	Connectable conductor cross-sections	Flexible With wire end ferrule, without plastic sleeve With wire end ferrule, with plastic sleeve	0.5 mm ² to 10 mm ² 0.5 mm ² to 10 mm ² 0.5 mm ² to 10 mm ²
	Insulation stripping length	11 mm	
	Tool	Screwdriver 1.0 x 4.0 mm	
	Tightening torque	1.5 to 1.8 Nm	

12.6.2 Motor connector

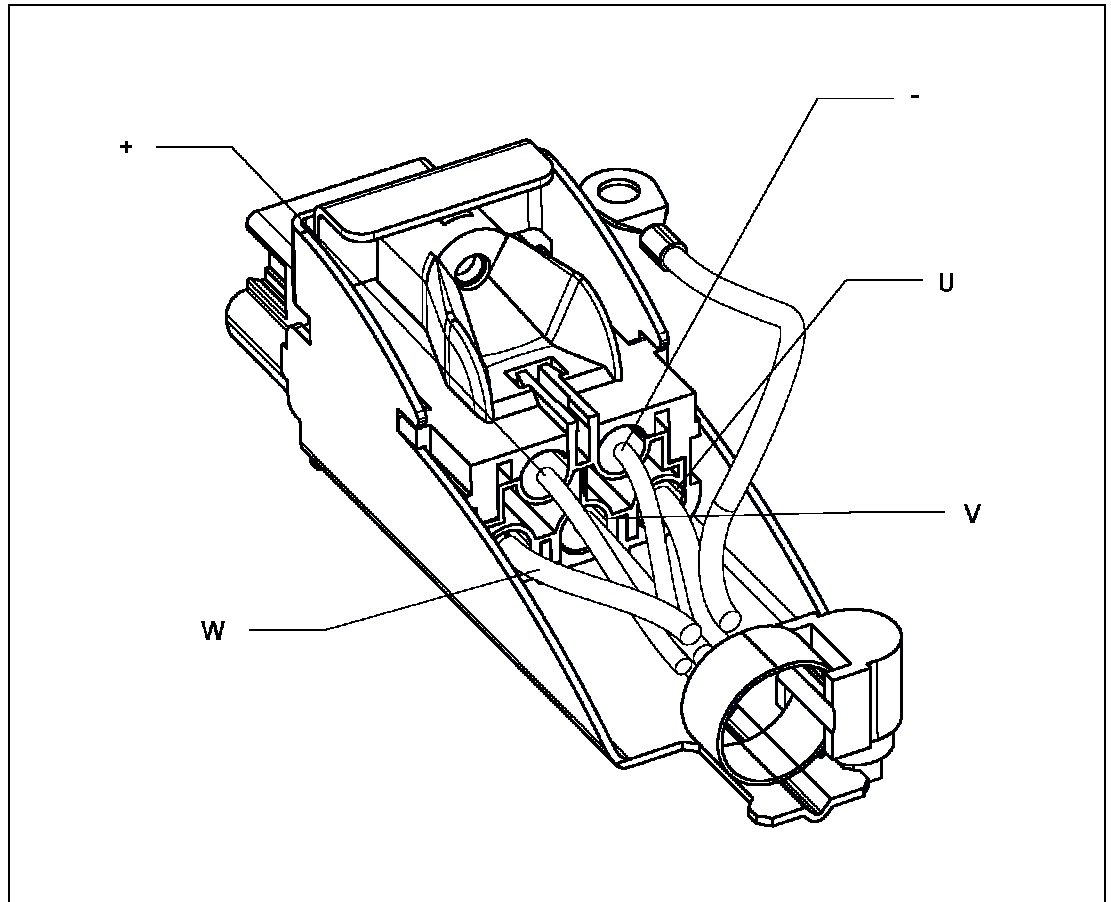

Figure 12-6 Motor Connector

The figure below shows how to remove the motor connector using a pair of engineer's pliers, for example, to pull the cable through narrow cable bushings.

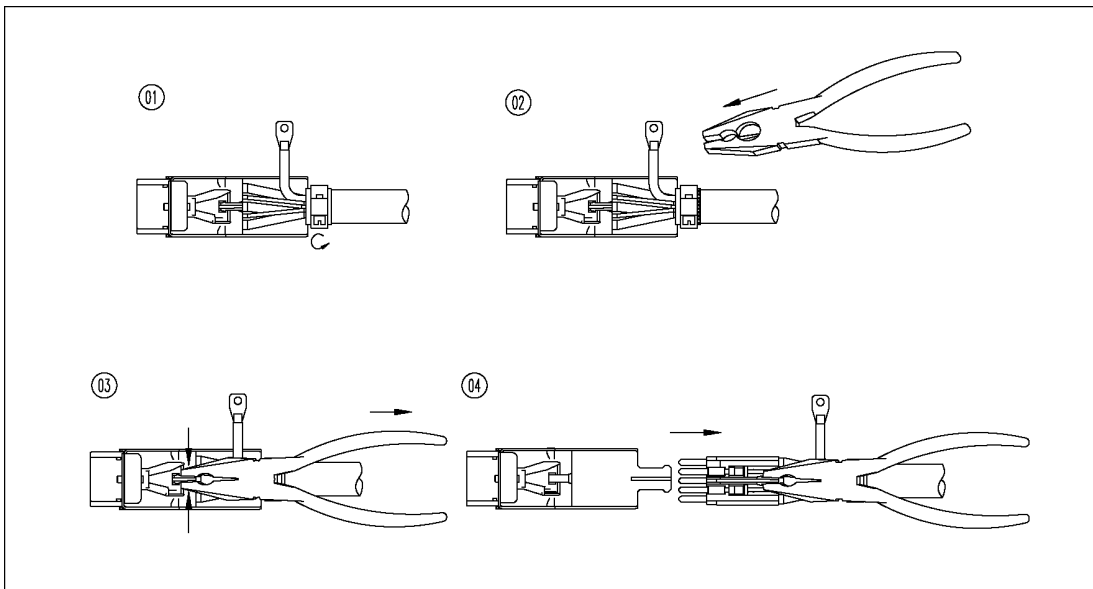

Figure 12-7 Removing the motor connector

The following figure shows how the motor connector is coded to prevent incorrect connection (especially relevant for Double Motor Modules).

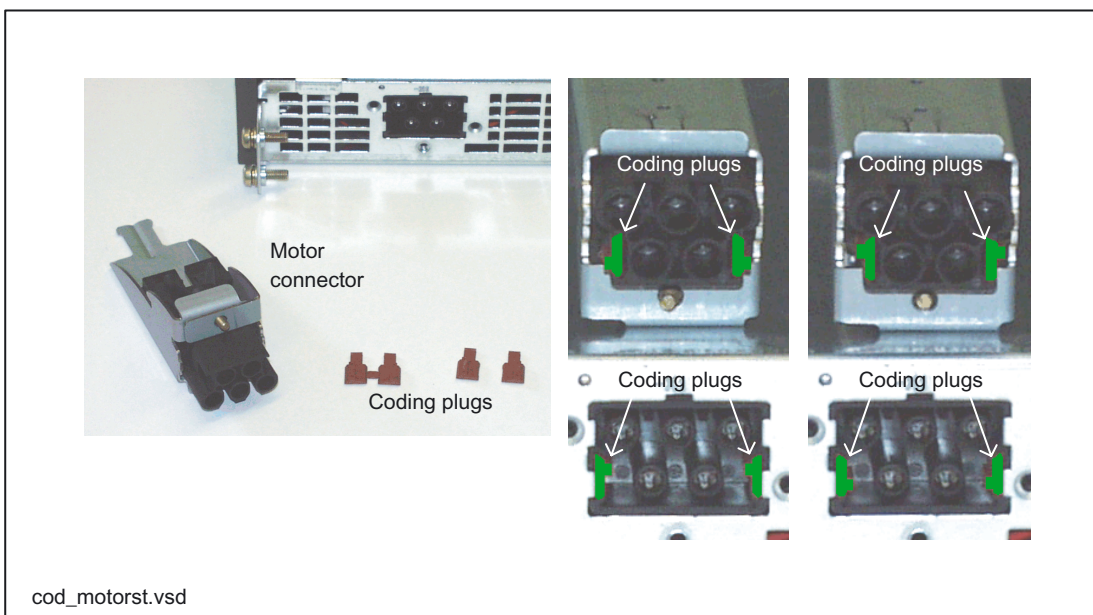

Figure 12-8 Coding the motor connector

The coding plugs are supplied with the motor cables.

12.6.3 Power connector (X1/X2)

with screw terminals

Structure and assembly

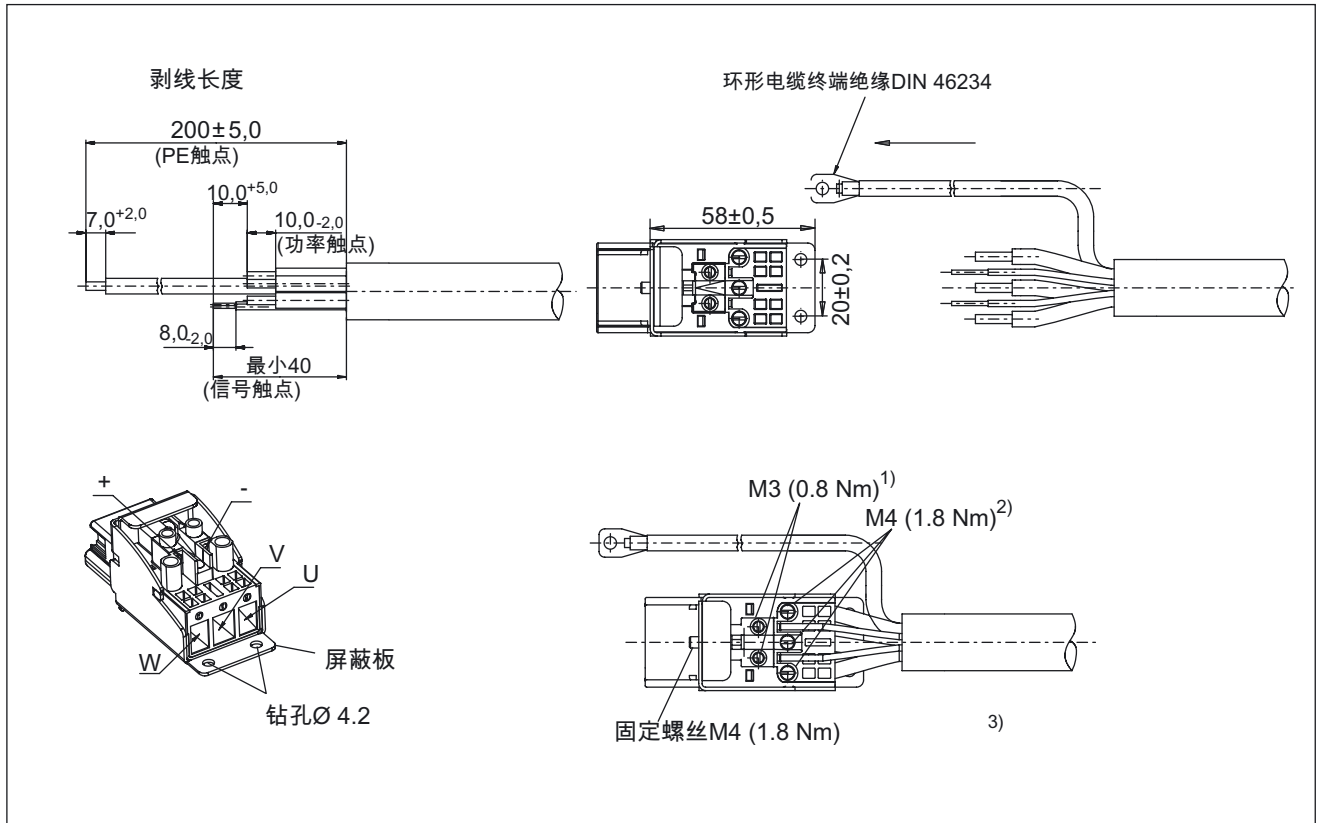

Figure 12-9 Setting up and installing the power supply connector (X1/X2)

Screwdriver

1) SZS 0.6 x 3.5

2) SZS 1.0 x 4.0

3) Torx TX20

Various options are available for the shield contact:

1. Shield contact on a toothed rail
The toothed rail should be fitted at a distance of ≤ 150 mm below the drive line-up with the greatest possible surface area. Wherever possible, the brake conductors must be kept physically separate from U/V/W.

Note

Measures must be taken on site to relieve strain on the cables.
Max. permissible cable tension in the connection direction: 100 N

2. Customer-specific shield contact

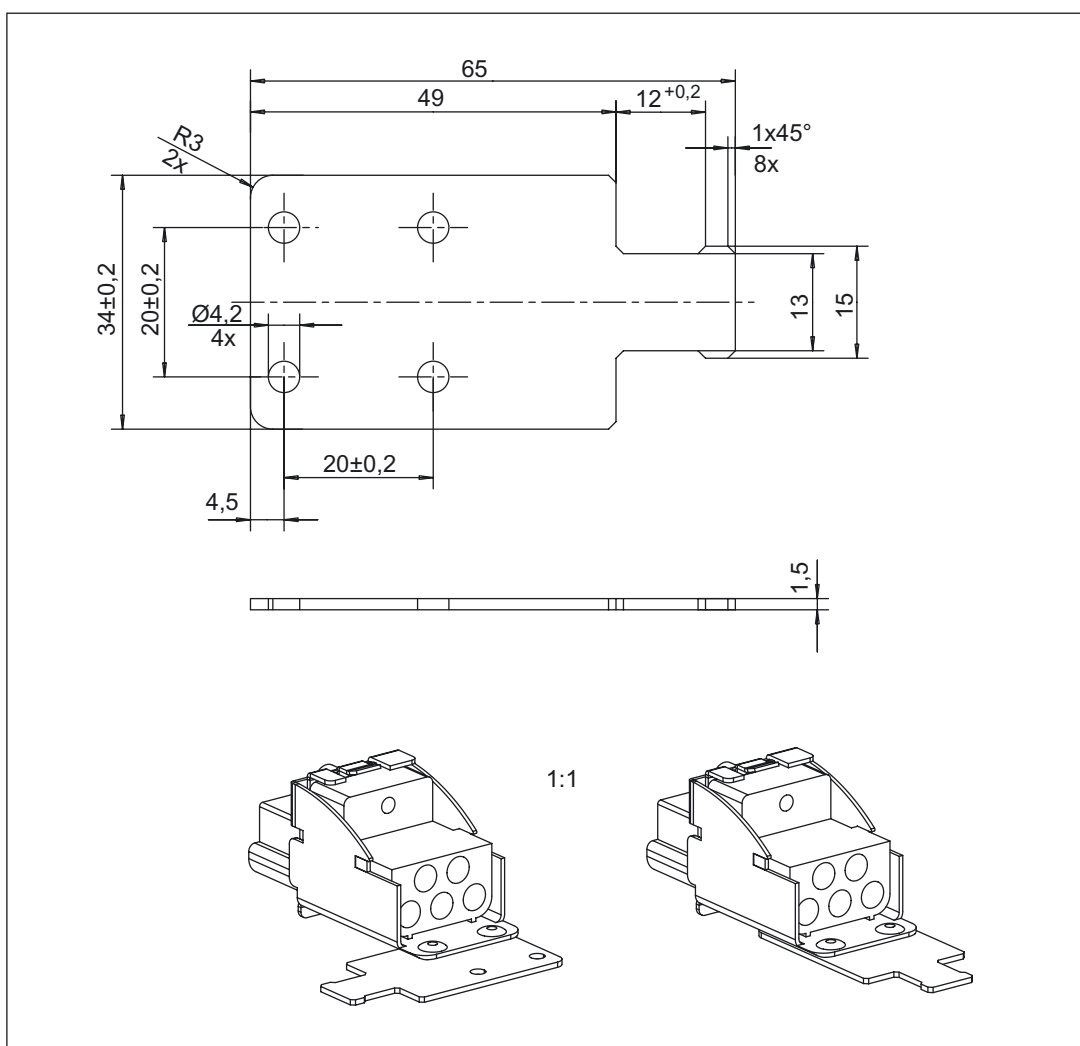

Figure 12-10 Example of a customer-specific metal shield contact
With both variants, the shield for the brake terminal wires must be applied together with the cable shield.

3. Securing a shield contact constructed by the customer on the shield plate.

12.6.4 24-V terminal adapter

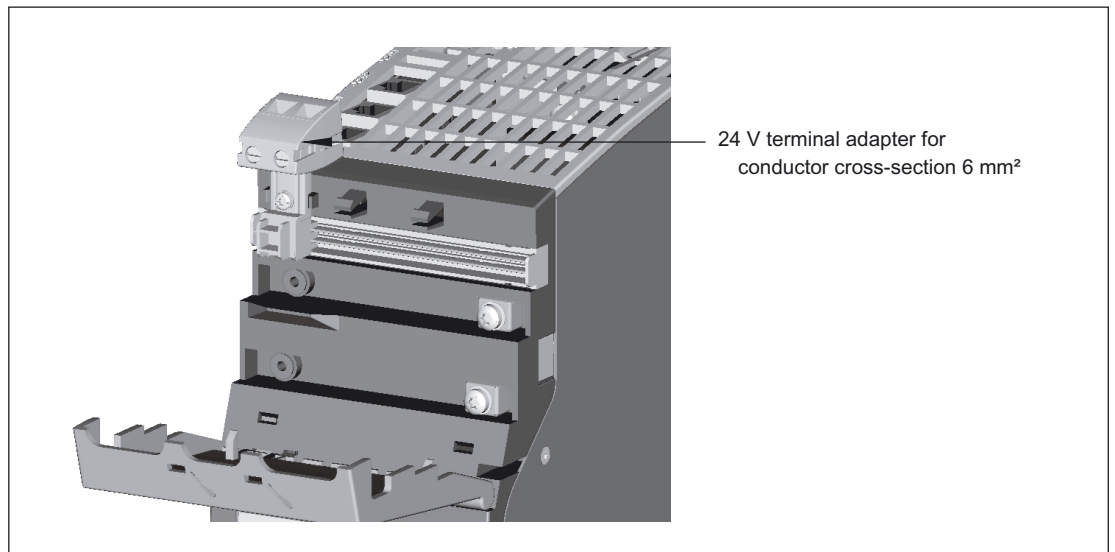

Figure 12-11 24 V terminal adapter

The terminal adapter can be fitted to any power module. To do so, a recess must be provided on the protective cover of the DC link using suitable pliers.

24 V terminal adapter for a conductor cross-section of 6 mm².
Supplied with the line modules and control supply modules.

12.7 Cooling

12.7.1 General

The following devices are available as cooling equipment:

- Internal liquid cooling (in preparation)
- External air cooling
- External liquid cooling

The decision in favor of one of these methods will depend on the prevailing ambient conditions and the cooling power required.

The ventilation clearances stated here must be observed. No other components or cables must be located in these areas.



Caution

If you do not observe the guidelines for installing SINAMICS equipment in the cabinet, this can significantly reduce the service life of the equipment and result in premature component failure.

Note

When the line reactor is being installed, it is best not to install it in the same cabinet (max. distance approx. 0.5 m). If necessary, it can be installed on the heat sink.

You must take into account the following specifications when installing a SINAMICS drive line-up:

- Ventilation clearance
- Cable routing
- Air guidance

Table 12-14 Ventilation clearances above and below the components

Component	Order number	Clearance [mm]
Line filter for line module 5 kW - 120 kW	6SL3000-0BExx-xAAx	100
Line reactor for active line module 16 kW – 120 kW	6SN1111-0AA00-xxAx	100
Line reactor for smart line module 5 kW – 10 kW	6SL3000-0CExx-0AAx	100
Active line module 16 kW – 55 kW 80 kW – 120 kW	6SL3130-7TExx-xAAx 6SL3130-7TExx-xAAx	80 80 (additional 50 in front of fan)
Smart line module 5 kW – 10 kW	6SL3130-6AExx-0AAx	80
Motor module < 132 A	6SL312x-1TExx-xAAx	80
Motor module 132 A and 200 A	6SL312x-1TE3x-xAAx	80 (additional 50 in front of fan)
Braking module	6SL3100-1AE31-0AAx	80
Control supply module	6SL3100-1DE22-0AAx	80
Capacitor Module	6SL3100-1CE14-0AAx	80

12.7.2 Ventilation

With cold-plate cooling, the SINAMICS devices must always be ventilated separately by means of a fan in the cabinet or by some other means.

When an external air heat sink is used, ventilation must also be provided outside the cabinet or by some other means.

Temperature measurement

The temperature of the power sections can be read via parameter r0037.

Temperature limits

1. For the maximum heat sink temperature, see the "Technical Specifications" for the power sections.
2. For the maximum internal cabinet temperature, see the "Technical Specifications" for the power sections.

Measures for remaining within temperature limits

1. Install one or more fans.
2. If necessary, the drive line-up can be operated with derating.

12.7.3 Anti-Condensation Measures

Special measures must be taken to prevent condensation.

Condensation occurs when the inlet temperature of the cooling medium is significantly lower than room temperature (ambient temperature).

The table below shows the dew points (in °C) for an atmospheric pressure of 1 bar (\approx installation altitude: 0...500 m). If the temperature of the cooling medium is below the specified value, condensation may occur (i.e. the temperature of the cooling medium must always be \geq the dew point temperature).

Table 12-15 Dew point temperature as a function of the relative air humidity (Φ) and the room temperature at an installation altitude of between 0 m and 500 m

T room °C	$\Phi=20\%$	$\Phi=30\%$	$\Phi=40\%$	$\Phi=50\%$	$\Phi=60\%$	$\Phi=70\%$	$\Phi=80\%$	$\Phi=85\%$	$\Phi=90\%$	$\Phi=90\%$	$\Phi=100\%$
10	<0	<0	<0	0.2	2.7	4.8	6.7	7.6	8.4	9.2	10
20	<0	2	6	9.3	12	14.3	16.4	17.4	18.3	19.1	20
25	0.6	6.3	10.5	13.8	16.7	19.1	21.2	22.2	23.2	24.1	24.9
30	4.7	10.5	14.9	18.4	21.3	23.8	26.1	27.1	28.1	29	29.9
35	8.7	14.8	19.3	22.9	26	28.6	30.9	32	33	34	34.9
38	11.1	17.4	22	25.7	28.8	31.5	33.8	34.9	36	36.9	37.9
40	12.8	19.1	23.7	27.5	30.6	33.4	35.8	36.9	37.9	38.9	39.9
45	16.8	23.3	28.2	32	35.3	38.1	40.6	41.8	42.9	43.9	44.9
50	20.8	27.5	32.6	36.6	40	42.9	45.5	46.6	47.8	48.9	49.9

The dew point also depends on the absolute pressure (i.e. the installation altitude).

Various measures can be taken to prevent condensation:

1. Temperature-controlled valves in the supply line.
In the cooling circuit, a temperature-controlled valve must be provided in the supply line.
2. Water temperature control.
The water temperature is adjusted in line with the room temperature. This is the preferred method with high room temperatures, low water temperatures, and high air humidity.
3. Physical dehumidification.
This is only effective in closed spaces. This method involves condensing the air humidity in an air-to-water heat exchanger, which is continuously operated using the cold cooling water.
4. Installing a heater with a sufficient capacity in the cabinet.

To prevent condensation, a humidity detector can be used to monitor the air humidity. The humidity detector is not included in the scope of supply.

12.7.4 Power Loss of Components in Rated Operation

With cold-plate cooling, only part of the power loss remains in the cabinet. The table below shows the internal and external power loss of the components. The characteristic values apply for the following conditions:

- Line voltage for Line Modules 400 V
- Pulse frequency of the Motor Modules 4 kHz
- Rated pulse frequency of the Active Line Modules 8 kHz
- Operation of components with rated power

Overview: power loss in cold-plate cooling

Table 12-16 Overview: power loss in cold-plate cooling

	Unit	Internal power loss	External power loss	Total power loss
Active Line Modules				
16 kW	W	50	210	260
36 kW	W	110	520	630
55 kW	W	160	740	900
80 kW	W	250	1100	1350
120 kW	W	400	1800	2200
Smart Line Modules				
5 kW	W	-	-	89
10 kW	W	-	-	170
Single Motor Modules				
3A	W	12	18	30
5 A	W	20	35	55
9 A	W	30	50	80
18 A	W	65	100	165
30 A	W	70	220	290
85 A	W	130	620	750
200 A	W	350	1700	2050
Double Motor Modules				
2x3 A	W	34	36	70
2x5 A	W	40	65	105
2x9 A	W	60	100	160
2x18 A	W	70	250	320

Mean power loss in periodic duty is lower.

Electronic losses in Motor Modules/Line Modules

Table 12-17 Electronic losses in Motor Modules/Line Modules

Component		Cold plate	
		Current consumption [A]	Power loss [W]
Motor Modules	3 A	0.6	14.4
	5 A	0.6	14.4
	9 A	0.6	14.4
	18 A	0.6	14.4
	30 A	0.6	14.4
	45 A	0.7	16.8
	60 A	0.7	16.8
	85 A	1	24.0
	132 A	1.5	36.0
	200 A	1.5	36.0
	2x3 A	0.85	20.4
	2x5 A	0.85	20.4
	2x9 A	0.85	20.4
	2x18 A	0.95	22.8
Active Line Modules	16 kW	0.8	19.2
	36 kW	1	24.0
	55 kW	1.4	33.6
	80 kW	2	48.0
	120 kW	2.5	60.0
Smart Line Module	5 kW	0.65	15.6
	10 kW	0.7	16.8

Service and Maintenance

13.1 Replacing Components with Internal Liquid Cooling (in Preparation)

Component replacement largely depends on the setup of the liquid installation. With a serial connection system, the entire circuit is interrupted when components are replaced. With a parallel connection system, appropriate valves in the cooling pipes (not included in the component) mean that individual components can be removed from the line-up without the need to interrupt the cooling circuit.

To make it easier to replace components, you are advised to connect each component via self-closing valves.

Note

If the connectors are removed from the component, you must make sure that you use a new seal.

Spring-Loaded Terminals/Screw Terminals

Connectable conductor cross-sections of spring-loaded terminals

Table A-1 Spring-loaded terminals

Spring-loaded terminal type			
1	Connectable conductor cross-sections	Flexible With wire end ferrule, without plastic sleeve With wire end ferrule, with plastic sleeve	0.14 mm ² to 1.5 mm ² 0.25 mm ² to 1.5 mm ² 0.25 mm ² to 0.5 mm ²
	Insulation stripping length	7 mm	
	Tool	Screwdriver 0.4 x 2.0 mm	
2	Connectable conductor cross-sections	Flexible	0.08 mm ² to 2.5 mm ²
	Insulation stripping length	8 to 9 mm	
	Tool	Screwdriver 0.4 x 2.0 mm	

Connectable conductor cross-sections of screw terminals

Table A-2 Screw terminals

Screw terminal type			
1	Connectable conductor cross-sections	Flexible With wire end ferrule, without plastic sleeve With wire end ferrule, with plastic sleeve	0.14 mm ² to 1.5 mm ² 0.25 mm ² to 1.5 mm ² 0.25 mm ² to 0.5 mm ²
	Insulation stripping length	7 mm	
	Tool	Screwdriver 0.4 x 2.0 mm	
	Tightening torque	0.22 to 0.25 Nm	
2	Connectable conductor cross-sections	Flexible With wire end ferrule, without plastic sleeve With wire end ferrule, with plastic sleeve	0.2 mm ² to 2.5 mm ² 0.25 mm ² to 1 mm ² 0.5 mm ² to 1 mm ²
	Insulation stripping length	7 mm	
	Tool	Screwdriver 0.6 x 3.5 mm	
	Tightening torque	0.5 to 0.6 Nm	
3	Connectable conductor cross-sections	Flexible With wire end ferrule, without plastic sleeve With wire end ferrule, with plastic sleeve	0.2 mm ² to 2.5 mm ² 0.25 mm ² to 1 mm ² 0.25 mm ² to 1 mm ²
	Insulation stripping length	9 mm	
	Tool	Screwdriver 0.6 x 3.5 mm	
	Tightening torque	0.5 to 0.6 Nm	

Screw terminal type			
4	Connectable conductor cross-sections	Flexible With wire end ferrule, without plastic sleeve With wire end ferrule, with plastic sleeve	0.2 mm ² to 4 mm ² 0.25 mm ² to 4 mm ² 0.25 mm ² to 4 mm ²
	Insulation stripping length	7 mm	
	Tool	Screwdriver 0.6 x 3.5 mm	
	Tightening torque	0.5 to 0.6 Nm	
5	Connectable conductor cross-sections	Flexible With wire end ferrule, without plastic sleeve With wire end ferrule, with plastic sleeve	0.5 mm ² to 6 mm ² 0.5 mm ² to 6 mm ² 0.5 mm ² to 6 mm ²
	Insulation stripping length	12 mm	
	Tool	Screwdriver 1.0 x 4.0 mm	
	Tightening torque	1.2 to 1.5 Nm	
6	Connectable conductor cross-sections	Flexible With wire end ferrule, without plastic sleeve With wire end ferrule, with plastic sleeve	0.5 mm ² to 10 mm ² 0.5 mm ² to 10 mm ² 0.5 mm ² to 10 mm ²
	Insulation stripping length	11 mm	
	Tool	Screwdriver 1.0 x 4.0 mm	
	Tightening torque	1.5 to 1.8 Nm	

B

List of Abbreviations

Table B-1 List of abbreviations

Abbreviation	German	English
A		
A...	Warnung	Alarm
AC	Wechselstrom	Alternating Current
ADC	Analog-Digital-Konverter	Analog Digital Converter
AI	Analogeingang	Analog Input
ALM	Active Line Module	Active Line Module
AO	Analogausgang	Analog Output
AOP	Advanced Operator Panel	Advanced Operator Panel
ASC	Ankerkurzschluss	Armature Short-Circuit
ASCII	Amerikanische Code-Norm für den Informationsaustausch	American Standard Code for Information Interchange
B		
BB	Betriebsbedingung	Operating Condition
BERO	Firmenname für einen Näherungsschalter	Tradename for a type of proximity switch
BI	Binektoreingang	Binector Input
BIA	Berufsgenossenschaftliches Institut für Arbeitssicherheit	Berufsgenossenschaftliches Institut für Arbeitssicherheit (German Institute for Occupational Safety)
BICO	Binektor-Konnektor-Technologie	Binector Connector Technology
BLM	Basic Line Module	Basic Line Module
BOP	Basic Operator Panel	Basic Operator Panel
C		
C	Kapazität	Capacitance
C...	Safety-Meldung	Safety message
CAN	Controller Area Network	Controller Area Network
CBC	Kommunikationsbaugruppe CAN	Communication Board CAN
CBP	Kommunikationsbaugruppe PROFIBUS	Communication Board PROFIBUS
CD	Compact Disc	Compact Disc
CDS	Befehlsdatensatz	Command Data Set
CI	Konnectoreingang	Connector Input

List of Abbreviations

Abbreviation	German	English
CNC	Computerunterstützte numerische Steuerung	Computer Numerical Control
CO	Konnetor Ausgang	Connector Output
CO/BO	Konnetor-/Binektor Ausgang	Connector Output/Binector Output
COB-ID	CAN Object-Identification	CAN object identification
COM	Mittelkontakt eines Wechselkontaktes	Mid-position contact of a changeover contact
CP	Kommunikationsprozessor	Communications Processor
CPU	Zentralbaugruppe	Central Processing Unit
CRC	Checksummenprüfung	Cyclic Redundancy Check
CU	Control Unit	Control Unit
D		
DAC	Digital-Analog-Konverter	Digital Analog Converter
DC	Gleichstrom	Direct Current
DCN	Gleichstrom negativ	Direct Current Negative
DCP	Gleichstrom positiv	Direct Current Positive
DDS	Antriebsdatensatz	Drive Data Set
DI	Digitaleingang	Digital Input
DI/DO	Digitaleingang/-ausgang bidirektional	Bidirectional Digital Input/Output
DMC	DRIVE-CLiQ Module Cabinet (Hub)	DRIVE-CLiQ Module Cabinet (Hub)
DO	Digitalausgang	Digital Output
DO	Antriebsobjekt	Drive Object
DPRAM	Speicher mit beidseitigem Zugriff	Dual-Port Random Access Memory
DRAM	Dynamischer Speicher	Dynamic Random Access Memory
DRIVE CLiQ	Drive Component Link with IQ	Drive Component Link with IQ
DSC	Dynamic Servo Control	Dynamic servo control
I		
EDS	Geberdatensatz	Encoder Data Set
EGB	Elektrostatisch gefährdete Baugruppen	Electrostatic Sensitive Devices
EMK	Elektromagnetische Kraft	Electromagnetic force
EMC	Elektromagnetische Verträglichkeit	Electromagnetic Compatibility
EN	Europäische Norm	European Standard
EnDat	Geber-Schnittstelle	Encoder-Data-Interface
EP	Impulsfreigabe	Enable Pulses
ES	Engineering System	Engineering System
ESR	Erweitertes Stillsetzen und Rückziehen	Extended Stop and Retract
F		
F...	Störung	Fault
FAQ	Häufig gestellte Fragen	Frequently Asked Questions
FCC	Function Control Chart	Function Control Chart
FCC	Flussstromregelung	Flux Current Control
FEPROM	Schreib- und Lesespeicher nichtflüchtig	Flash-EPROM
FG	Funktionsgenerator	Function Generator

Abbreviation	German	English
FI	Fehlerstrom-Schutzschalter	Residual-Current Circuit-Breaker (RCCB)
FP	Funktionsplan	Function diagram
FW	Firmware	Firmware
G		
GC	Global-Control-Telegram (Broadcast-Telegramm)	Global Control Telegram (broadcast telegram)
GSD	Gerätstammdatei: beschreibt die Merkmale eines PROFIBUS-Slaves	Device master file: describes the features of a PROFIBUS slave
GSV	Gate Supply Voltage	Gate Supply Voltage
H		
HF	Hochfrequenz	High Frequency
HFD	Hochfrequenzdrossel	High frequency reactor
HLG	Hochlaufgeber	Ramp-Function Generator
HMI	Mensch-Maschine-Schnittstelle	Human Machine Interface
HTL	Logik mit hoher Störschwelle	High threshold logic
HW	Hardware	Hardware
I		
i. V.	In Vorbereitung: diese Eigenschaft steht zur Zeit nicht zur Verfügung	In preparation: this feature is currently not available
IBN	Inbetriebnahme	Commissioning
I/O	Eingang/Ausgang	Input/Output
ID	Identifizierung	Identifier
IEC	Internationale Norm in der Elektrotechnik	International Electrotechnical Commission
IGBT	Bipolartransistor mit isolierter Steuerelektrode	Insulated Gate Bipolar Transistor
IL	Impulslöschung	Pulse suppression
IT	Drehstromversorgungsnetz ungeerdet	Insulated three-phase supply
J		
JOG	Tippen	Jogging
K		
KDV	Kreuzweiser Datenvergleich	Data cross-checking
KIP	Kinetische Pufferung	Kinetic buffering
Kp	Proportionalverstärkung	Proportional gain
KTY	Spezieller Temperatursensor	Positive temperature coefficient temperature sensor
L		
L	Induktivität	Inductance
LED	Leuchtdiode	Light Emitting Diode
LSB	Niederwertigstes Bit	Least Significant Bit
LSS	Netzschalter	Line Side Switch

List of Abbreviations

Abbreviation	German	English
M		
M	Masse	Reference potential, zero potential
MB	Megabyte	Megabyte
MCC	Motion Control Chart	Motion Control Chart
MDS	Motordatensatz	Motor Data Set
MLFB	Maschinenlesbare Fabrikatebezeichnung	Machine-readable product designation
MMC	Mensch-Maschine-Kommunikation	Man Machine Communication
MSB	Höchstwertigstes Bit	Most Significant Bit
MSCY_C1	Zyklische Kommunikation zwischen Master (Klasse 1) und Slave	Master Slave Cycle Class 1
N		
N. C.	Nicht angeschlossen	Not Connected
N...	Keine Meldung oder Interne Meldung	No Report
NAMUR	Normenarbeitsgemeinschaft für Mess- und Regeltechnik in der chemischen Industrie	Standardization association for measurement and control in chemical industries
NC	Öffner	Normally Closed contact
NC	Numerische Steuerung	Numerical Control
NEMA	Normengremium in USA (United States of America)	National Electrical Manufacturers Association
NM	Nullmarke	Zero mark
NO	Schliesses	Normally Open contact
O		
OEM	Original Equipment Manufacturer	Original Equipment Manufacturer
OLP	Busstecker für Lichtleiter	Optical Link Plug
OMI	Option Module Interface	Option Module Interface
P		
p...	Einstellparameter	Adjustable parameter
PcCtrl	Steuerungshoheit	Master Control
PDS	Leistungsteildatensatz	Power Module Data Set
PE	Schutzerde	Protective Earth
PELV	Schutzkleinspannung	Protective Extra Low Voltage
PG	Programmiergerät	Programming device
PI	Proportional Integral	Proportional Integral
PID	Proportional Integral Differential	Proportional Integral Differential
PLC	Speicherprogrammierbare Steuerung (SPS)	Programmable Logic Controller
PLL	Baustein zur Synchronisierung	Phase Locked Loop
PNO	PROFIBUS Nutzerorganisation	PROFIBUS user organisation
PRBS	Weißes Rauschen	Pseudo Random Binary Signal
PROFIBUS	Serieller Datenbus	Process Field Bus
PS	Stromversorgung	Power Supply
PTC	Positiver Temperaturkoeffizient	Positive Temperature Coefficient
PTP	Punkt zu Punkt	Point To Point
PWM	Pulsweitenmodulation	Pulse Width Modulation
PZD	PROFIBUS Prozessdaten	PROFIBUS process data

Abbreviation	German	English
R		
r ...	Beobachtungsparameter (nur lesbar)	Display parameter (read only)
RAM	Speicher zum Lesen und Schreiben	Random Access Memory
RCCB	Fehlerstrom-Schutzschalter	Residual-Current Circuit-Breaker
RCD	Fehlerstrom-Schutzschalter	Residual Current Device
RJ45	Norm: beschreibt eine 8-polige Steckverbindung mit Twisted-Pair Ethernet	Standard Describes an 8-pole plug connector with twisted pair Ethernet.
RKA	Rückkühlanlage	Recooling system
RO	Nur lesbar	Read Only
RPDO	Receive Process Data Object	Receive Process Data Object
RS232	Serielle Schnittstelle	Serial interface
RS485	Norm: beschreibt die Physik einer digitalen Schnittstelle	Standard Describes the physical characteristics of a digital serial interface.
S		
S1	Dauerbetrieb	Continuous duty
S3	Aussetzbetrieb	Periodic duty
SBC	Sichere Bremsenansteuerung	Safe Brake Control
SBH	Sicherer Betriebshalt	Safe operating stop
SBR	Sichere Bremsrampe	Safe braking ramp
SE	Sicherer Software-Endschalter	Safe software limit switch
SG	Sicher reduzierte Geschwindigkeit	Safely reduced speed
SGA	Sicherheitsgerichteter Ausgang	Safety-related output
SGE	Sicherheitsgerichtetes Eingangssignal	Safe input signal
SH	Sicherer Halt	Safe standstill
SI	Safety Integrated	Safety Integrated
SIL	Sicherheitsintegrität	Safety Integrity Level
SLM	Smart Line Module	Smart Line Module
SLVC	Geberlose Vektorregelung	Sensorless Vector Control
SM	Sensor Module	Sensor Module
SMC	Sensor Module Cabinet	Sensor Module Cabinet
SN	Sicherer Software-Nocken	Safe software cam
SPC	Sollwertkanal	Setpoint Channel
SPS	Speicherprogrammierbare Steuerung	Programmable Logic Controller (PLC)
STW	PROFIBUS Steuerwort	PROFIBUS Control Word
T		
TB	Terminal Board	Terminal Board
TIA	Totally Integrated Automation	Totally Integrated Automation
TM	Terminal Module	Terminal Module
TN	Drehstromversorgungsnetz geerdet	Grounded three-phase supply
Tn	Nachstellzeit	Integral time
TPDO	Transmit Process Data Object	Transmit Process Data Object
TT	Drehstromversorgungsnetz geerdet	Grounded three-phase supply
TTL	Transistor-Transistor-Logic	Transistor Transistor Logic

List of Abbreviations

Abbreviation	German	English
U		
UL	Underwriters Laboratories Inc.	Underwriters Laboratories Inc.
USV	Unterbrechungsfreie Stromversorgung	Uninterruptible power supply
V		
VC	Vektorregelung	Vector control
Vdc	Zwischenkreisspannung	DC link voltage
VDE	Verband Deutscher Elektrotechniker	Association of German Electrical Engineers
VDI	Verband Deutscher Ingenieure	Association of German Electrical Engineers
Vpp	Volt Spitze zu Spitze	Volt peak to peak
VSM	Voltage Sensing Module	Voltage sensing module
W		
WZM	Werkzeugmaschine	Machine tool
X		
XML	Erweiterbare Auszeichnungssprache (Standardsprache für Web-Publishing und Dokumentenmanagement)	Extensible Markup Language
Z		
ZK	Zwischenkreis	DC Link
ZSW	PROFIBUS Zustandswort	PROFIBUS status word

References

SINAMICS Documentation

Catalogs

/D11.1/ SINAMICS G110 Inverter Chassis Units 0.12 kW to 3 kW

Order no.: E86060-K5511-A111-A2, edition: 10.2005

/D11/ SINAMICS G130 Drive Converter Chassis Units, SINAMICS G150 Drive Converter Cabinet Units

Order no.: E86060-K5511-A101-A2, edition: 07.2004

/D21.1/ SINAMICS S120 Vector Control Drive System

Order no.: E86060-K5521-A111-A1, edition: 04.2005

/D21.2/ SINAMICS S120 Servo Control Drive System

Order no.: E86060-K5521-A121-A1, edition: 04.2004

/D21.3/ SINAMICS S150 Drive Converter Cabinet Units

75 kW to 1200 kW

Order no.: E86060-K5521-A131-A1, edition: 05.2004

Related catalogs

/ST70/ SIMATIC Components for Totally Integrated Automation, catalog ST70

Ordering information

Order no.: E86060-K4670-A111-A9, edition: 10.2004

/PM10/ Motion Control System SIMOTION, catalog PM10

Ordering information

Order no.: E86060-K4910-A101-A5, edition: 07.2005

Interactive catalogs

/CA01/ The Offline Mall of Automation and Drives

CD-ROM

Order no.: E86060-D4001-A100-C3, edition: 10.2004

/Mall/ A&D Mall, Catalog and Online Ordering System

<http://www.siemens.com/automation/mall>

Electronic documentation

/CD2/ SINAMICS

The SINAMICS System

Order no.: 6SL3097-2CA00-0YG2, edition: 07.2005

User Documentation

/BA1/ SINAMICS G150

Operating Manual

Order no.: On request, edition: 06.2005

/BA2/ SINAMICS G130

Operating Manual

Order no.: On request, edition: 06.2005

/BA3/ SINAMICS S150

Operating Manual

Order no.: On request, edition: 06.2005

/GH1/ SINAMICS S120

Equipment Manual for Control Units and Additional System Components

Order no.: 6SL3097-2AH00-0BP2, edition: 06.2005

/GH2/ SINAMICS S120

Equipment Manual for Booksize Power Sections

Order no.: 6SL3097-2AC00-0BP2, edition: 06.2005

/GH3/ SINAMICS S120

Equipment Manual for Chassis Power Sections

Order no.: 6SL3097-2AE00-0BP0, edition: 12.2004

/GH4/ SINAMICS S120

Equipment Manual for Booksize Cold-Plate Power Sections

Order no.: 6SL3097-2AJ00-0BP2, edition: 06.2005

/GS1/ SINAMICS S120

Getting Started

Order no.: 6SL3097-2AG00-0BP2, edition: 06.2005

/IH1/ SINAMICS S120

Commissioning Manual

Order no.: 6SL3097-2AF00-0BP3, edition: 06.2005

/FH1/ SINAMICS S120

Functional Manual

Order no.: 6SL3097-2AB00-0BP1, edition: 06.2005

/IH2/ SINAMICS S120

CANopen Commissioning Manual

Order no.: 6SL3097-2AA00-0BP1, edition: 12.2004

/LH1/ SINAMICS S

List Manual

Order no.: 6SL3097-2AP00-0BP3, edition: 06.2005

Further Supplementary Documentation

1 Drive ES Basic V5.1

Function Description

Engineering System for Drives from the SIEMENS A&D Product Range

Order no.: 6SW1700-0JA00-0BA0, edition: 08.2001

2 SIMOTION Engineering System

Handling

Order no.: 6AU1900-1AB32-0BA0, edition: 12.2004

/PJAL/ SIMODRIVE, SIMOVERT MASTERDRIVES, SINAMICS

General Part for Synchronous Motors

Planning Guide

Order no.: 6SN1197-0AD07-0BP2, edition: 12.2004

/PFK7S/ SINAMICS Synchronous Motors 1FK7

Planning Guide

Order no.: 6SN1197-0AD16-0BP0, edition: 12.2004

/PFT6S/ SINAMICS Synchronous Motors 1FT6

Planning Guide

Order no.: 6SN1197-0AD12-0BP0, edition: 12.2004

/PFK7/ SIMODRIVE and SIMOVERT MASTERDRIVES Synchronous Motors 1FK7

Planning Guide

Order no.: 6SN1197-0AD06-0BP2, edition: 07.2005

/PFT6/ SIMODRIVE and SIMOVERT MASTERDRIVES Synchronous Motors 1FT6

Planning Guide

Order no.: 6SN1197-0AD02-0BP1, edition: 07.2005

PROFIBUS Documentation

/P1/ PROFIBUS-DP/DPV1 IEC 61158

Basic Information, Tips and Tricks for Users

Hüthig; Manfred Popp; 2nd edition

ISBN 3-7785-2781-9

/P2/ PROFIBUS-DP, Getting Started

PROFIBUS User Organization; Manfred Popp

Order no.: 4.071

/P3/ Decentralization with PROFIBUS-DP

Architecture and Fundamentals, Configuration and Use of PROFIBUS-DP with SIMATIC S7

SIEMENS; Publicis MCD Verlag; Josef Weigmann, Gerhard Kilian

Order no.: A19100-L531-B714

ISBN 3-89578-074-X

/P4/ Manual for PROFIBUS Networks, SIEMENS

Order no.: 6GK1970-5CA20-0BA0

/P5/ PROFIBUS Profile PROFIdrive Profile Drive Technology

PROFIBUS User Organization

Haid- und Neu-Straße 7, D-76131 Karlsruhe

Order no.: 3.172 Version 3.1 November 2002

/IKPI/ SIMATIC NET, Industrial Communication and Field Devices

Catalog

Order no.: E86060-K6710-A101-B4, edition: 2005

/PDP/ PROFIBUS Installation Guidelines

Installation Guideline for PROFIBUS-FMS/DP

Installation and Wiring Recommendation for RS 485 Transmission

Order no. 2.111 (German), Version 1.0

Order no. 2.112 (English), Version 1.0

Documentation for Safety Equipment

Note

For more information about technical documentation for Safety Integrated, visit the following address:

<http://www.siemens.com/safety>

The following list contains some of the safety-related documentation available.

/LVP/ Low-Voltage Switchgear

Catalog

Order no.: E86060-K1002-P101-A5, edition: 2005

/LV10/ Controlgear for Industry

Catalog

Order no.: E86060-K1002-A101-A4, edition: 2004

/LV20/ BERO - Sensors for Automation

Catalog:

Order no.: E86060-K1803-A101-A3, edition: 2004

/LV30/ Products and Systems for Low-Voltage Power Distribution

Catalog

Order no.: E86060-K1801-A101-A4, edition: 2004

/MRL/ Directive 98/37/EG of the European Parliament and Council

Machinery Directive

Bundesanzeiger-Verlags GmbH, edition: 22.06.1998

/SIAH/ Safety Integrated

Application Manual

Order no.: 6ZB5000-0AA01-0BA1, 5th edition

/SICD/ Safety Integrated

CD-ROM

Order no.: E20001-D10-M103-X-7400, edition: 09.2004

Index

A

- Active Line Modules with Internal Air Cooling, 5-1
- Air heat sink, 2-4
- Anti-Condensation Measures, 12-34
- Autotransformer, 4-34

B

- Basic Line Filter for Active Line Modules, 4-4
- Braking Resistors, 10-11

C

- Cable Installation, 12-21
- Cable Shields, 12-21
- Capacitor Module, 10-13
- Cold plate with external air heat sink, 1-1, 2-2
- Cold plate with external liquid heat sink, 1-1
- Cold plate with internal liquid cooling (in preparation), 1-1, 3-1
- Component replacement, 13-1
- Components
 - Active Line Modules with Internal Air Cooling, 5-1
 - Basic Line Filter for Active Line Modules, 4-4
 - Capacitor Module, 10-13
 - Control Supply Module (CSM), 10-17
 - DC link adapter, 11-21
 - DC link supply adapter, 11-12
 - DRIVE-CLiQ Coupling, 11-32
 - DRIVE-CLiQ Flanged Coupling, 11-27
 - Line filters for Smart Line Modules, 4-14
 - Line reactors for Active Line Modules, 4-20
 - Line reactors for Smart Line Modules, 4-24
 - Motor Module with Internal Air Cooling, 7-1
 - Smart Line Modules with Internal Air Cooling, 6-1
 - Wideband Line Filter for Active Line Modules, 4-9
- Connection adapters, 8-1
- Control Supply Module (CSM), 10-17

D

- DC link adapter, 11-21
- DC link supply adapter, 11-12
- Dimension drawings
 - Basic Line Filter for Active Line Modules, 4-8
 - Line filters for Smart Line Modules, 4-18
 - Line reactors for Smart Line Modules, 4-27
 - Wideband Line Filter for Active Line Modules, 4-13
- Dimension Drawings
 - Active Line Modules, 5-9
 - Braking module, 10-8
 - Capacitor Module, 10-15
 - Connection adapter, 8-2
 - Control supply module, 10-22
 - DC link adapter, 11-24
 - DC link supply adapter, 11-16
 - DRIVE-CLiQ Coupling, 11-33
 - DRIVE-CLiQ Flanged Coupling, 11-29
 - Line reactors for Active Line Modules, 4-22
 - Motor Modules, 7-10
 - Smart line modules, 6-9
 - Voltage Clamping Module, 10-28
- Directives, 12-3
- Drive group, 12-14
- DRIVE-CLiQ Coupling, 11-32
- DRIVE-CLiQ Flanged Coupling, 11-27

E

- Electrical Connections
 - DC link adapter, 11-26
 - DC link supply adapter, 11-20
- EMC Directive, 12-20
- Equipotential Bonding, 12-24

H

- Heat dissipation, 12-32

I

Installation

- Braking module, 10-9
- Capacitor Module, 10-16
- DC link adapter, 11-25
- DC link supply adapter, 11-18
- DRIVE-CLiQ Flanged Coupling, 11-31
- Voltage Clamping Module, 10-29

Installing an external heat sink, 5-11, 6-10, 7-13

Installing the connection adapter, 8-4

Interface descriptions

- Smart Line Module with cold plate (5 kW and 10 kW), 6-3

Interface Descriptions

- Active line module, 5-3
- DC link adapter, 11-22
- DC link supply adapter, 11-14

Isolating transformer, 4-36

L

Line connection, 4-1

Line connection via RCCB, 4-38

Line Connections, 4-31

Line filters for Smart Line Modules, 4-14

Line reactors for Active Line Modules, 4-20, 4-21

Line reactors for Smart Line Modules, 4-24, 4-25

M

Motor Connector, 12-27

Motor Module with Internal Air Cooling, 7-1

O

Overcurrent, 12-11

Overcurrent Protection, 12-6

P

Power connector (X1/X2), 12-29

Power loss, 12-35

Power supply, 12-10

Power Supply Units, 12-9

R

Residual-Current Circuit-Breakers, 4-38

S

Safety information

- Line filters, 4-5, 4-10, 4-15

Safety Information

- Active Line Module, 5-1
- Braking Module, 10-2
- Capacitor Module, 10-13
- Control Supply Module, 10-18
- DRIVE-CLiQ Coupling, 11-27, 11-32
- DRIVE-CLiQ Flanged Coupling, 11-27, 11-32
- Motor Module, 7-1
- Smart Line Modules with Internal Air Cooling, 6-1
- Voltage Clamping Module, 10-25

Screw terminals, 12-25, A-1

Smart Line Modules with Internal Air Cooling, 6-1

Spring-loaded terminals, 12-25, A-1

Standards, 12-3

System Data, 1-3

T

Technical specifications

- Basic Line Filter for Active Line Modules, 4-8

- Line filters for Smart Line Modules, 4-19

- Motor Modules, 7-15

- Wideband Line Filter for Active Line Modules, 4-14

Technical Specifications

- Active Line Modules, 5-13

- Braking module, 10-10

- Capacitor Module, 10-17

- Control Supply Module, 10-23

- DRIVE-CLiQ Coupling, 11-34

- DRIVE-CLiQ Flanged Coupling, 11-32

- Line Reactors, 4-23

- Smart Line Modules, 6-13

- Voltage Clamping Module, 10-29

Temperature limits, 12-33

Temperature measurement, 12-33

Terminal adapter, 12-31

V

Ventilation, 12-33

Voltage Clamping Module (VCM), 10-24

W

Wideband Line Filter for Active Line Modules, 4-9

To
 SIEMENS AG
 A&D MC BMS
 Postfach 3180
 D-91050 Erlangen
 Tel.: +49 (0) 180 / 5050 - 222 (Hotline)
 Fax.: +49 (0) 9131 / 98 - 63315 (Documentation)
 email: motioncontrol.docu@erlf.siemens.com

Recommendation
Corrections
for document: SINAMICS S120 Manual (GH4) Manufacturer Documentation
Equipment Manual
Order no.: 6SL3097-2AJ00-0BP2 Edition: 06.2005
Should you come across any printing errors when reading this publication, please notify us on this sheet. Suggestions for improvement are also welcome.

From
Name
_____ Your company address/dept.
Address
_____ Postal code: City:
Phone: /
Fax: /

Recommendations and/or suggestions

Overview of SINAMICS Documentation (06/2005)

General Documentation/Catalogs

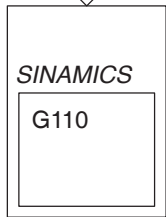

D11.1
Converter Chassis Units
0.12 – 3 kW

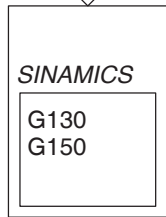

D11
Converter Chassis Units
Converter Cabinet Units

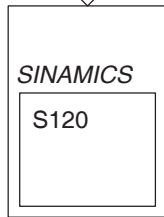

– D21.1: Vector Control Drive System
– D21.2: Servo Control Drive System

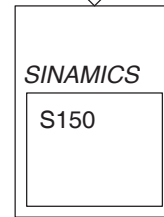

D21.3
Vector Control Cabinet Units
75 – 1200 kW

Manufacturer/Service-Documentation

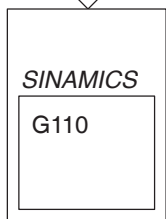

– Getting Started
– Operating Instructions
– List Manual

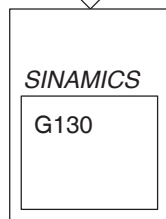

– Operating Instructions
– List Manual

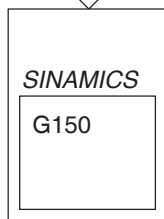

– Operating Instructions
– List Manual

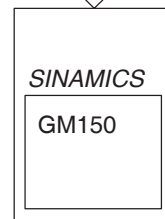

– Operating Instructions
– List Manual

Manufacturer/Service-Documentation

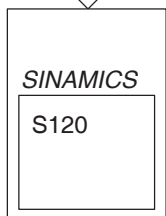

– Getting Started
– Equipment Manual Control Units and Additional System Components
– Equipment Manual Booksize Power Sections
– Equipment Manual Booksize Power Sections Cold-Plate
– Equipment Manual Chassis Power Sections
– Installation & Start-Up Manual
– Installation & Start-Up Manual CANopen
– Function Manual
– List Manual

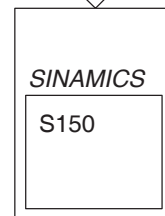

– Operating Instructions
– List Manual

Manufacturer/Service-Documentation

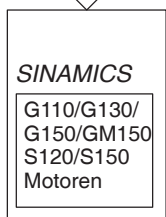

DOCONCD

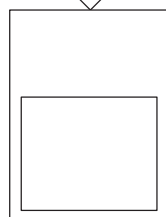

Planning Guide
Motors

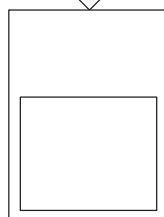

EMC
Installation Guideline

Siemens AG
Automation & Drives
Motion Control Systems
Postfach 3180
91050 ERLANGEN
GERMANY

www.siemens.com/motioncontrol

© Siemens AG, 2005
Subject to change without prior notice
Order no.: 6SL3097-2AJ00-0BP2

Printed in Germany