

System Manual 09/2007



sinamics

Cabinet integration
SINAMICS S120 Booksize / SIMODRIVE

SIEMENS

Cabinet integration, SINAMICS S120 Booksize / SIMODRIVE System Manual

Preface

Safety instructions

1

Information on cabinet
cooling

2

Arrangement of components
in the cabinet

3

Leakproofness of the cabinet

4

Line connection

5

Miscellaneous

6

Operator controls and
control panels

7

Wearing parts, maintenance



8

Fields of application for
cabinet cooling devices

9

Safety Guidelines

This manual contains notices you have to observe in order to ensure your personal safety, as well as to prevent damage to property. The notices referring to your personal safety are highlighted in the manual by a safety alert symbol, notices referring only to property damage have no safety alert symbol. These notices shown below are graded according to the degree of danger.

 DANGER
indicates that death or severe personal injury will result if proper precautions are not taken.
 WARNING
indicates that death or severe personal injury may result if proper precautions are not taken.
 CAUTION
with a safety alert symbol, indicates that minor personal injury can result if proper precautions are not taken.
CAUTION
without a safety alert symbol, indicates that property damage can result if proper precautions are not taken.
NOTICE
indicates that an unintended result or situation can occur if the corresponding information is not taken into account.

If more than one degree of danger is present, the warning notice representing the highest degree of danger will be used. A notice warning of injury to persons with a safety alert symbol may also include a warning relating to property damage.

Qualified Personnel

The device/system may only be set up and used in conjunction with this documentation. Commissioning and operation of a device/system may only be performed by **qualified personnel**. Within the context of the safety notes in this documentation qualified persons are defined as persons who are authorized to commission, ground and label devices, systems and circuits in accordance with established safety practices and standards.

Prescribed Usage

Note the following:

 WARNING
This device may only be used for the applications described in the catalog or the technical description and only in connection with devices or components from other manufacturers which have been approved or recommended by Siemens. Correct, reliable operation of the product requires proper transport, storage, positioning and assembly as well as careful operation and maintenance.

Trademarks

All names identified by ® are registered trademarks of the Siemens AG. The remaining trademarks in this publication may be trademarks whose use by third parties for their own purposes could violate the rights of the owner.

Disclaimer of Liability

We have reviewed the contents of this publication to ensure consistency with the hardware and software described. Since variance cannot be precluded entirely, we cannot guarantee full consistency. However, the information in this publication is reviewed regularly and any necessary corrections are included in subsequent editions.

Preface

This documentation contains instructions on and examples of the arrangement of control and drive components in the control cabinet and their cooling (heat dissipation) using the example of the SINAMICS S120 booksize and SIMODRIVE 611 device types, including the SIMOTION and SINUMERIK drive-related controllers, referred to in the following as "device combination", and instructions on setting up in compliance with EMC requirements.

Most of the instructions relate to device combinations with "internal cooling", where all of the heat loss occurs inside the cabinet. Particular reference is made in some chapters to different types of cooling such as "external cooling", "water cooling" or "cold plate".

Part of the content of this documentation was devised in a working group with the following companies:

Audi AG

DaimlerChrysler AG

EPLAN Software & Service GmbH & Co. KG

Felsomat GmbH & Co. KG

NILES - SIMMONS Industrieanlagen GmbH

Rittal GmbH & Co. KG

Siemens AG

Many instructions and examples can be applied to other device types by analogy.

If you do not follow these instructions and/or the instructions in the device-specific technical user documentation, this can lead to malfunctions and significantly reduce the service life of the equipment, and result in premature component failure.

An approximate description of the thermal correlations can be provided by the Arrhenius equation:

- A temperature rise of approx. 10 K causes a halving of service life
- A temperature rise of approx. 10 K causes a doubling of the failure rate

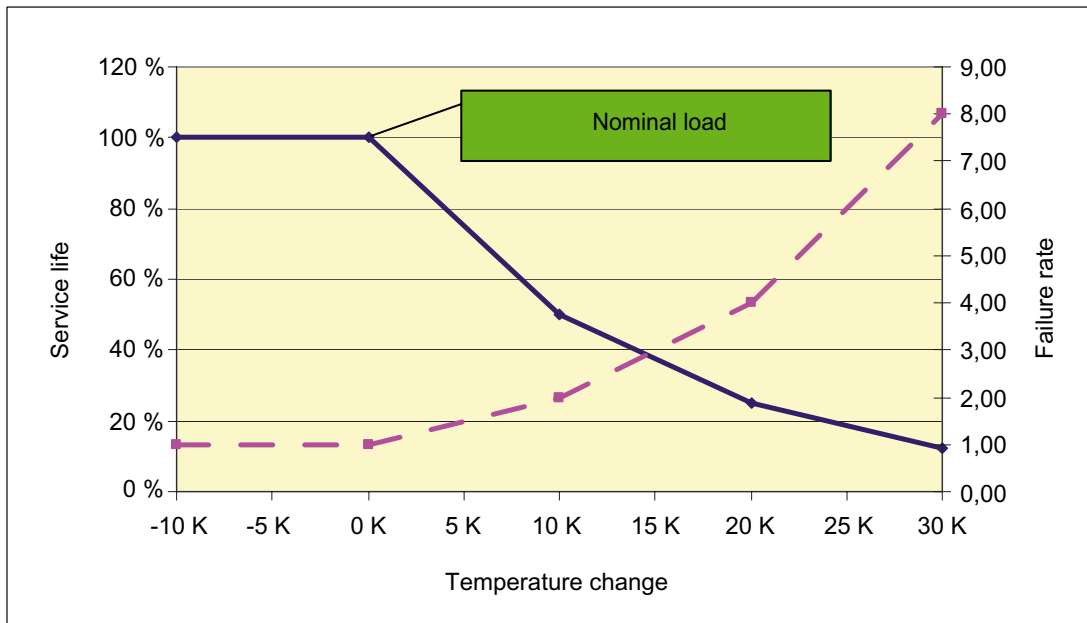

Figure 1-1 Service life and failure rate according to the Arrhenius equation

Examples from practical experience

The following examples illustrate how markedly the temperatures rise if the installation guidelines are not observed. The effect on failure rates and service life is determined with the aid of the chart, "Service life and failure rate according to the Arrhenius equation".

Example 1: Cable duct spacing on SIMODRIVE 611

In operation under reference conditions, temperatures in the interior of the device are established in accordance with the left-hand illustration in operation with a defined load given correct installation with 100 mm spacing for the cable ducts.

If under identical conditions the spacing of the cable ducts is reduced to approximately 40 mm as shown in configuration A, the temperatures rise by about 10 K. The failure rate rises to roughly double the usual figure as a result. Service life is shortened to approximately 50 %.

If under identical conditions the spacing of the cable ducts is reduced to approximately 15 mm as shown in configuration B, the temperatures rise by about 16 K. The failure rate rises to roughly three times the usual figure as a result. Service life is shortened to approximately 30 %.

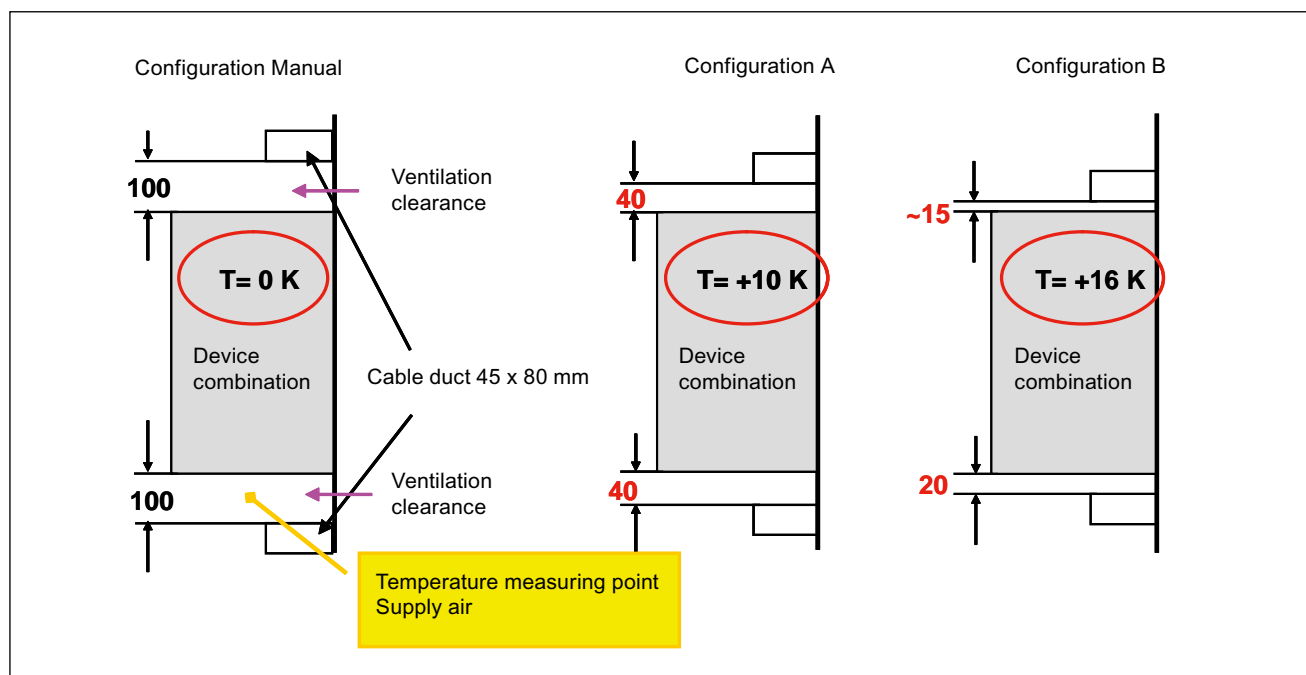

Figure 1-2 Rise in temperature due to non-observance of clearances

Example 2: Cables on the ventilation grille of 50 mm-wide SIMODRIVE 611 modules

In operation under reference conditions, temperatures in the interior of the device are established in accordance with the left-hand illustration in operation with a defined load given correct installation without cables on the ventilation grille.

If under identical conditions a cable is laid on the ventilation grille, the temperatures rise by about 10 K. The failure rate rises to roughly double the usual figure as a result. Service life is shortened to approximately 50 %.

If under identical conditions two cables are laid on the ventilation grille, the temperatures rise by about 20 K. The failure rate rises to roughly four times the usual figure as a result. Service life is shortened to approximately 25 %.

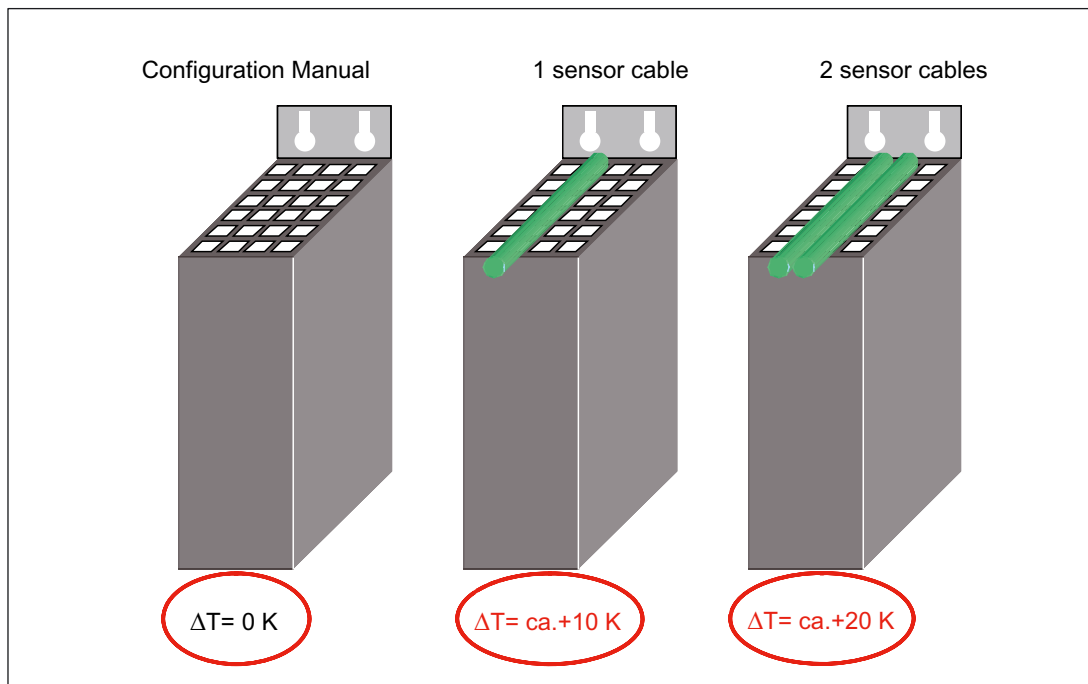

Figure 1-3 Rise in temperature caused by covering the ventilation grilles on 55 mm modules

On wider modules the effect of laying cables on the ventilation grille is reduced.

Table of contents

	Preface	5
1	Safety instructions	11
2	Information on cabinet cooling	13
	2.1 Estimating heat dissipation	13
	2.2 Air guidance for cabinet cooling units with an external circuit	14
	2.3 Air circulation in the control cabinet	15
	2.3.1 Air flow rate	15
	2.3.2 Direction of air flow	15
	2.3.3 Target for cooling air	17
	2.3.4 Prevention of condensation when using cooling units	19
	2.3.5 Draining condensate	19
	2.3.6 Temperature setting	20
	2.4 Ventilation clearances	21
	2.4.1 Ventilation clearances above and below the device combination	21
	2.4.2 Laying cables on ventilation grilles	22
3	Arrangement of components in the cabinet	23
	3.1 Arrangement of the drive line-up according to EMC rules	23
	3.2 Arrangement of line filter, line reactor, infeed	24
	3.3 Shielded cables	25
	3.3.1 Examples of shield connections	25
	3.3.2 Plug connections	26
	3.3.3 Cable lengths	26
4	Leakproofness of the cabinet	27
	4.1 Example of openings	28
	4.2 Air-to-water heat exchanger, water-cooled components	28
	4.3 External cooling, cold plate	29
5	Line connection	31
	5.1 Protection	31
	5.2 Protective conductor, protective bonding	32
6	Miscellaneous	33
	6.1 Setting controls	33
	6.2 Screwed connections of current-conducting parts	33
	6.3 External fans	33
	6.4 Examples	34
7	Operator controls and control panels	35

8	Wearing parts, maintenance	37
9	Fields of application for cabinet cooling devices	39
	Index.....	43

Safety instructions

It is essential to follow the safety instructions given in the device-specific technical user documentation under all circumstances.

The binding document for configuring the respective device types is always the device-specific technical user documentation.

Information on cabinet cooling

The advancing miniaturization of electronic components and increasing packing density in electronic packages and control cabinets has led to an increase in the sensitivity of the electronic systems to influences such as dust, moisture and temperature. In particular, removing the heat produced by systems in order to cool control cabinets imposes high demands on the cabinet air conditioning.

This section draws your attention to points that need to be borne in mind in order to achieve proper cabinet air conditioning with cooling units.

It is recommended that you should monitor the functioning of the cooling measures and in the event of any malfunction shut down the device combination.

Failure to comply with these rules is likely to lead to overheating and as a consequence to reduced service life or equipment failure.

2.1 Estimating heat dissipation

In practice, several hundred watts of power loss can be dissipated via the surface of the cabinet by natural convection. As a rough guide, you can assume 50 W per m² of free cabinet surface area given a 10 K temperature difference with respect to the shop temperature.

Example 3: A control cabinet with a width of 2 m, a height of 2 m and a depth of 0.5 m arranged with its back to a wall has an effective surface area of approximately 7 m² and is therefore able to dissipate some 350 W.

If the losses in the cabinet are higher than this, other cooling measures have to be implemented.

The power loss figures for the individual components can be taken from the device-specific technical user documentation.

Pulsed or braking resistors can also be set up outside the cabinet in order to reduce power losses inside the cabinet and thus also the cooling requirements.

As a rough estimate of the power loss, with internal heat dissipation the assumption is approximately 5 % of the input power to the drive line-up, as this is generally the largest power loss generator in the cabinet.

Example 4: An infeed of 36 kW results in a power loss of 1.8 kW which needs to be dissipated.

Example 5: For a cabinet of the type described in Example 3, $1.8 \text{ kW} - 0.35 \text{ kW} = 1.45 \text{ kW}$ must be removed by other means, for example a cooling unit.

2.2 Air guidance for cabinet cooling units with an external circuit

The air inlets and outlets of cabinet cooling units should be spaced at least 200 mm from each other and from the wall in an external circuit. If it is not possible to maintain this spacing from each other, suitable air baffles must be used to prevent the creation of a ventilation short-circuit.

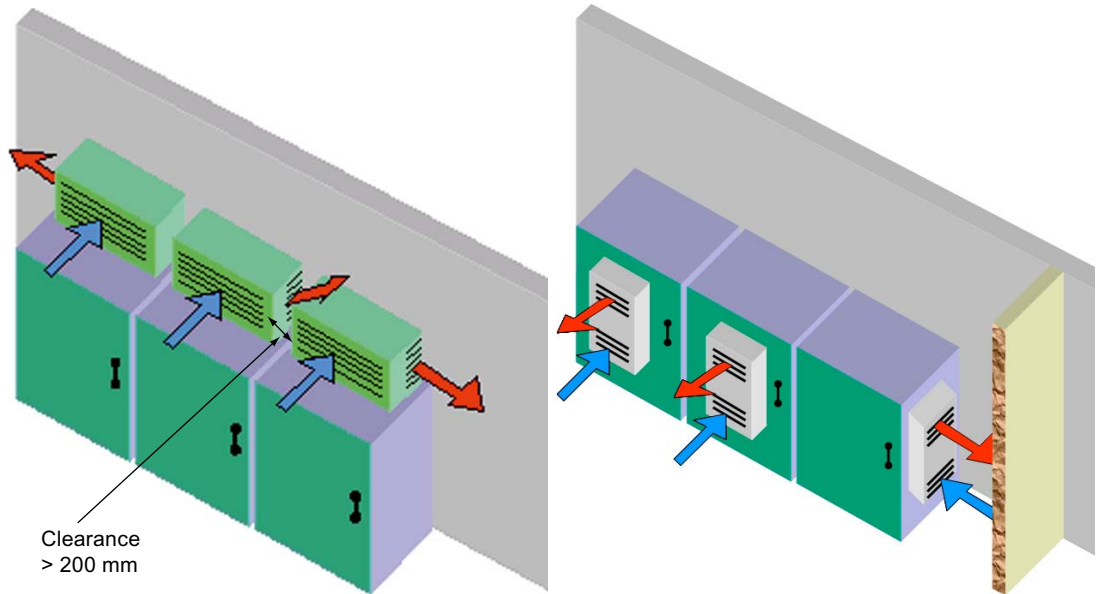

Optimum air guidance, roof-mounted cooling units

Optimum air guidance, wall-mounted cooling units

2.3 Air circulation in the control cabinet

2.3.1 Air flow rate

In order to safeguard heat dissipation from the device combination, in addition to the required cooling measures it must be ensured that minimum volumes of air are circulated inside the cabinet. Further details about this can be taken from the device-specific technical user documentation.

Uniform air circulation in the cabinet must be ensured.

2.3.2 Direction of air flow

Cooling of the devices is based on natural convection and/or forced cooling with fans. In both cases the direction of the cooling air in the device combination requiring cooling must be in the opposite direction to gravity, from the bottom upwards.

If there are other air circuits in the cabinet, for example from filter fans or cooling units, it must be ensured that the air flows do not counterbalance each other but have an additional effect.

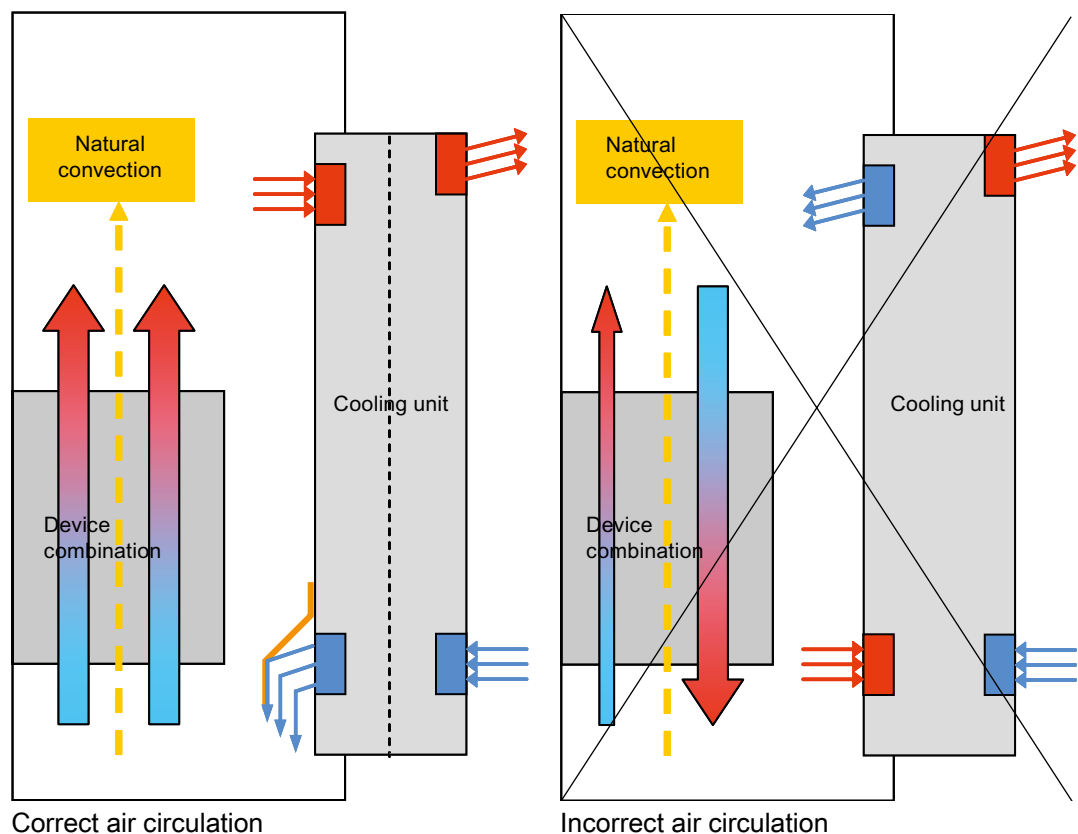

Blowing cold air directly onto electrical equipment should be avoided.

The distance between the air outlet of the air conditioner and the electronic equipment must be at least 200 mm.

Examples:

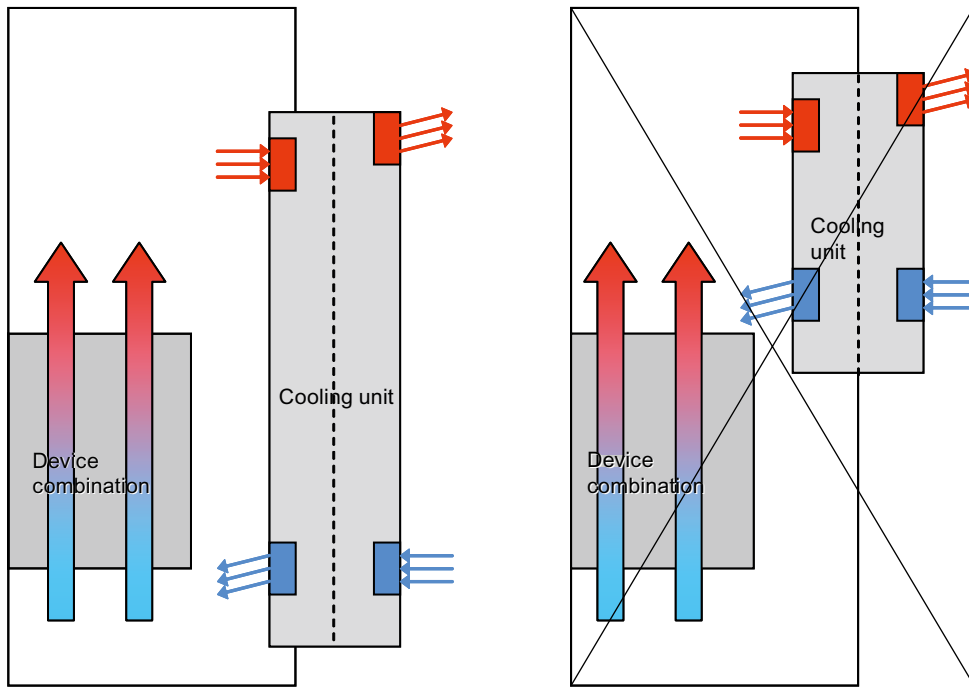

Figure 2-1 Correct and incorrect arrangement of wall-mounted cooling units

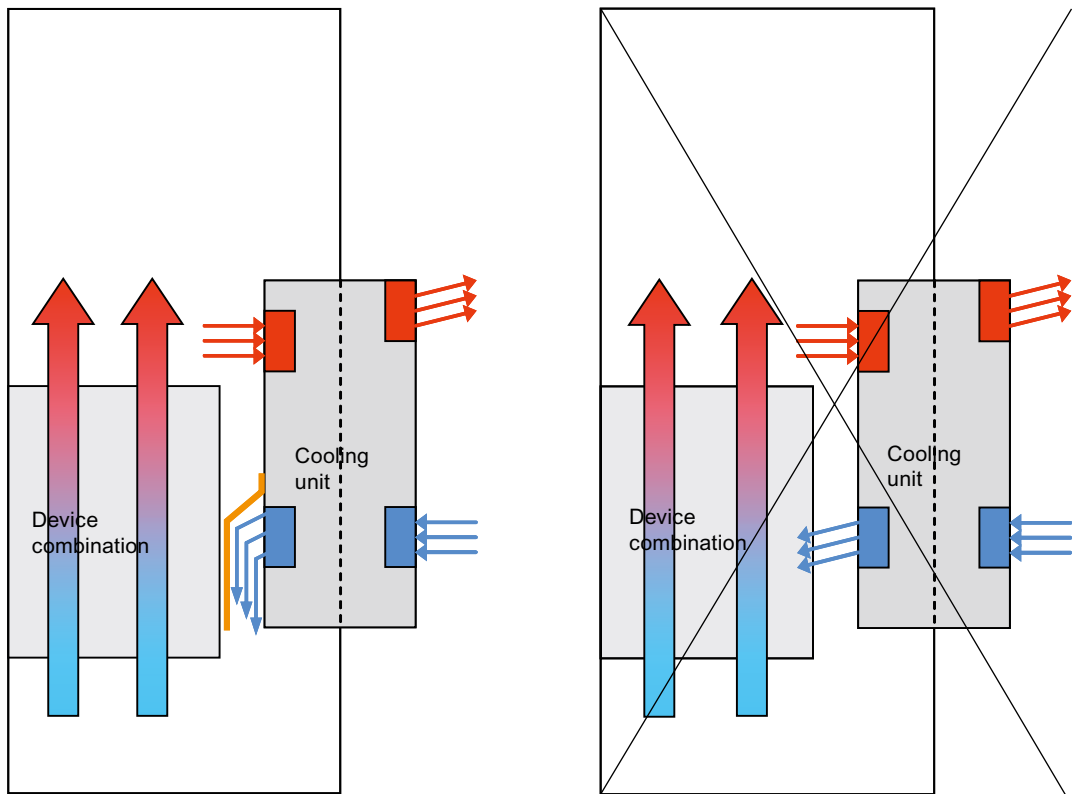

Figure 2-2 Correct and incorrect arrangement of wall-mounted cooling units

2.3.3 Target for cooling air

The target for the cooling air is the area of the cabinet with high power loss, usually the drive line-up. The cooling air should be directed at as large an area of the target as possible by positioning the cooling unit appropriately or guiding the cooling air through hoses or ducts, for example.

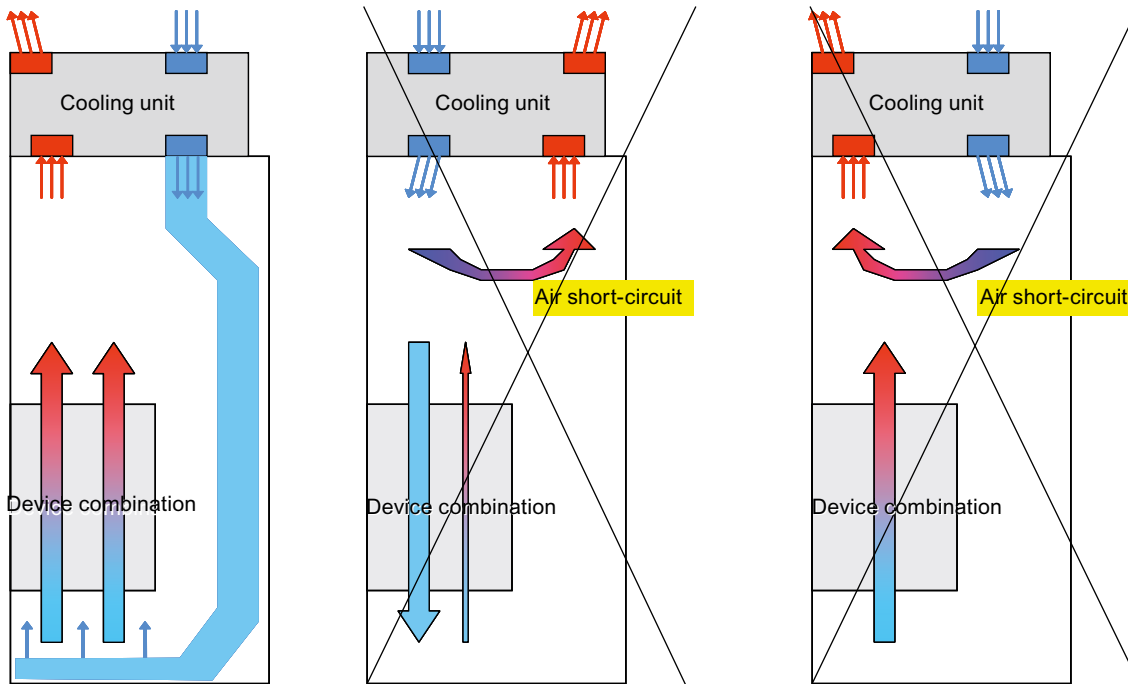

Figure 2-3 Correct and incorrect arrangement of roof-mounted cooling units

Note: if duct systems are used, the output of the cooling unit can be reduced. The maximum length of duct systems should therefore not exceed 3 m.

Rule of thumb:

introduce cold air as low down as possible, and extract warm air as high up as possible.

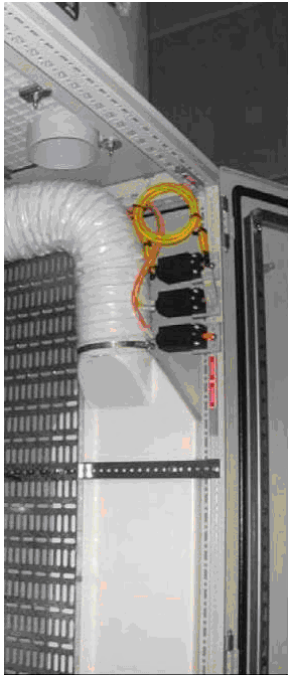

Figure 2-4 Example of an air duct from RITTAL GmbH & Co. KG

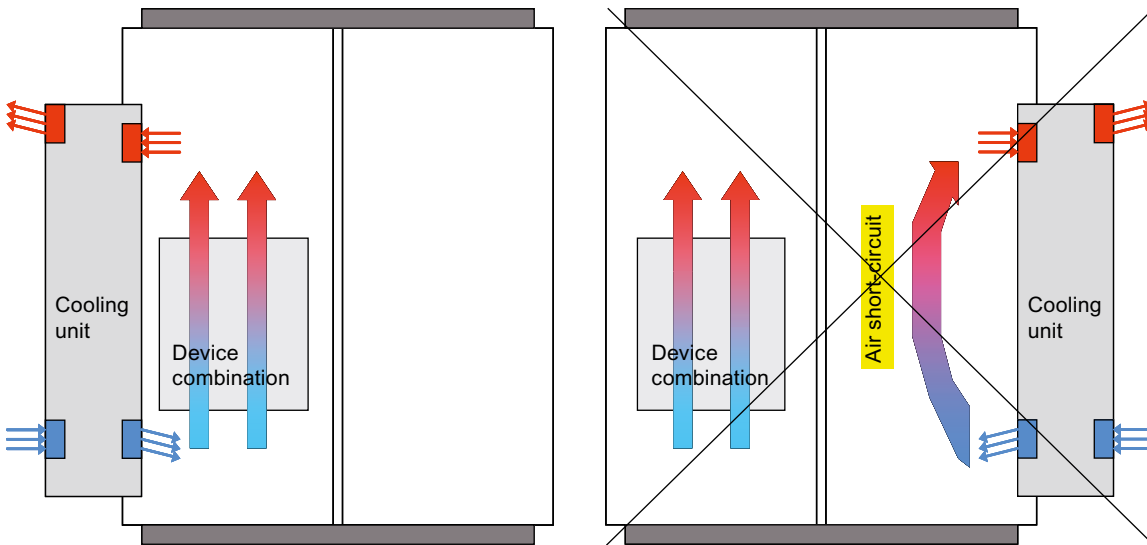
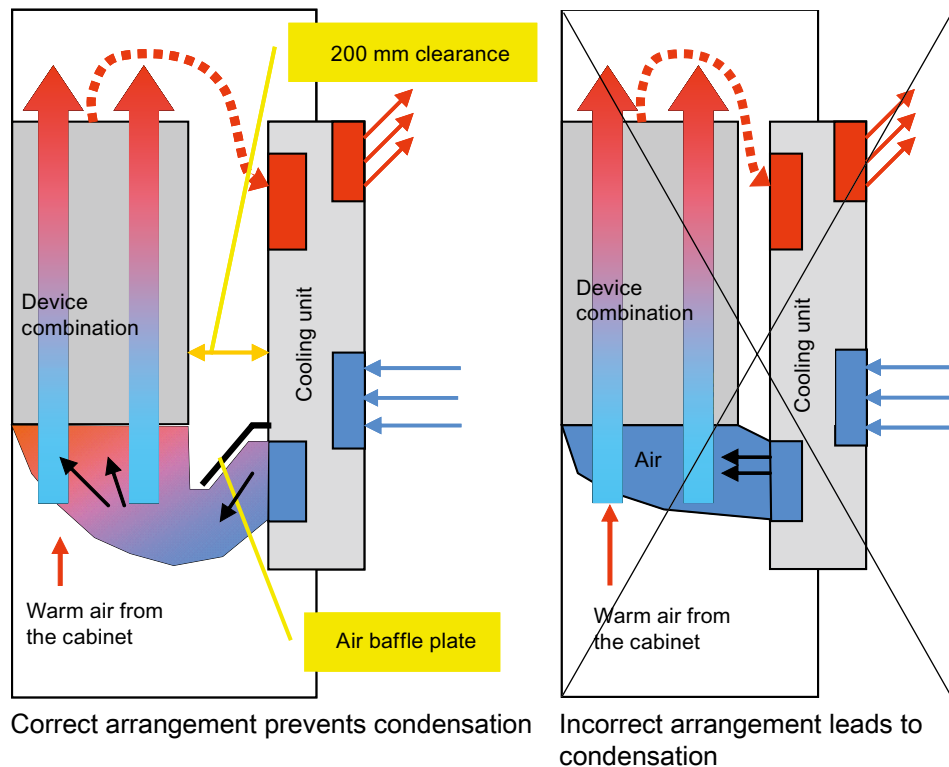

Figure 2-5 Correct and incorrect arrangement of wall-mounted cooling units

2.3.4 Prevention of condensation when using cooling units

If air conditioners are used, the relative humidity of the expelled air increases as the air in the air conditioner cools and may fall below the dew point.

It must be ensured, for example either by using air baffle plates or maintaining a minimum distance of 200 mm between the air outlet of the cooling unit and the device combination, that the cold moist air blown out of the air conditioner is able to mix with warm cabinet air before the air enters the device combination. This mixing with warm, dry cabinet air reduces the relative humidity to uncritical values.



Correct arrangement prevents condensation

Incorrect arrangement leads to condensation

2.3.5 Draining condensate

After the cabinet is closed and the cooling unit started, condensation forms. The amount of condensate arising also increases if there are leaks in the cabinet or if the cabinet doors are open. Refer also to the section headed "Leakproofness of the cabinet". The condensate must be drained from the cabinet without compromising the degree of protection according to IEC 60529.

It is recommended that the cooling units should be switched off by door contact switches when doors are open.

Especially if a cooling unit is mounted on the roof, make sure that no condensate can drip into components beneath it.

Condensate must be either trapped or evaporated.

2.3.6 Temperature setting

It is recommended that the temperature should be set to approximately 35°C.

Setting the internal temperature of the cabinet too low causes excessive wear on the cooling unit, very large quantities of condensate, unnecessarily high energy consumption and excessively high relative humidity with the possibility of further general condensation. Equipment failure must then be expected.

If there is a large difference between the internal temperature of the cabinet and the ambient temperature in the shop, there is a risk of condensation forming when the cabinet is opened, resulting in equipment failure.

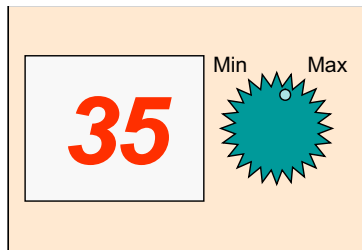

Optimum setting

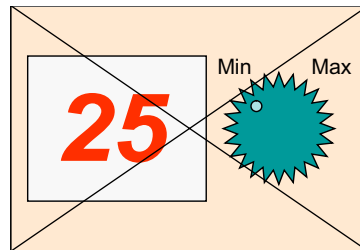

Setting too low

2.4 Ventilation clearances

Failure to maintain the clearances causes significantly elevated temperatures inside the components, leading to failures and considerably shorter service life.

2.4.1 Ventilation clearances above and below the device combination

Minimum clearances must be maintained above and below the components in order to guarantee proper routing of the cooling air. This especially applies to cable ducts. The minimum clearance does not apply to associated parts such as fans.

The specified clearances apply to internal and external cooling.

Further details can be taken from the device-specific technical user documentation.

Examples:

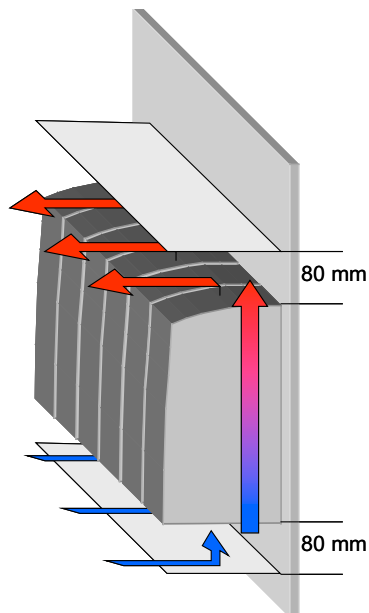

Clearances for SINAMICS S120 booksize
≥80 mm

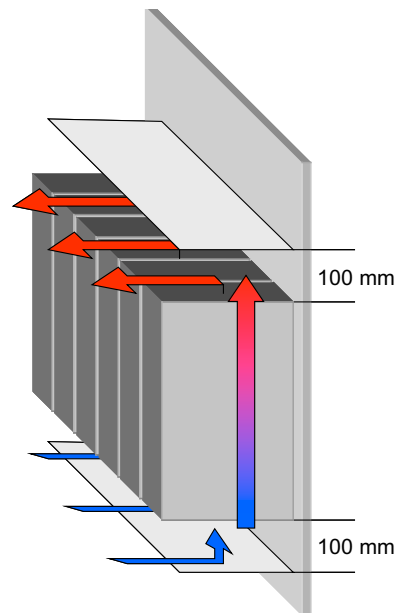

Clearances for SIMODRIVE 611
≥100 mm

2.4.2 Laying cables on ventilation grilles

Especially if the components are narrow, heat dissipation from the devices is considerably impeded if cables are laid on the ventilation grilles.

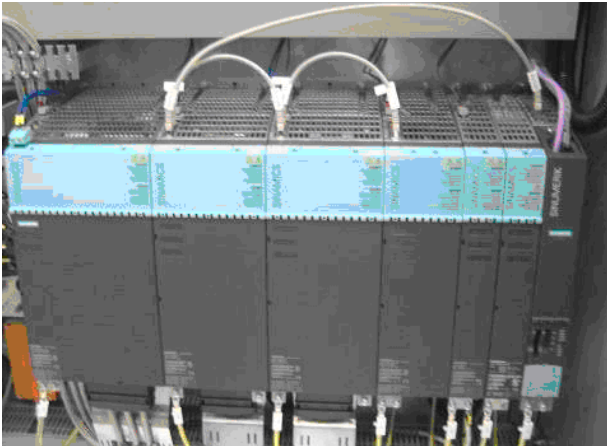

Good cable laying on SINAMICS S120 booksize



Good cable laying on SIMODRIVE

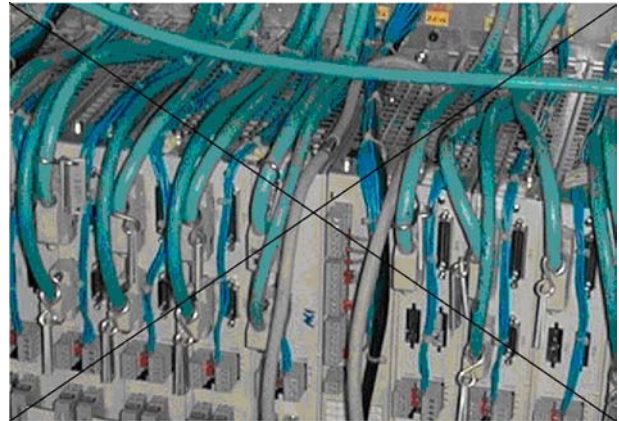

Poor cable laying on SIMODRIVE

Arrangement of components in the cabinet

In order to ensure reliable and trouble-free operation throughout the service life of the equipment, certain important layout rules need to be observed.

3.1 Arrangement of the drive line-up according to EMC rules

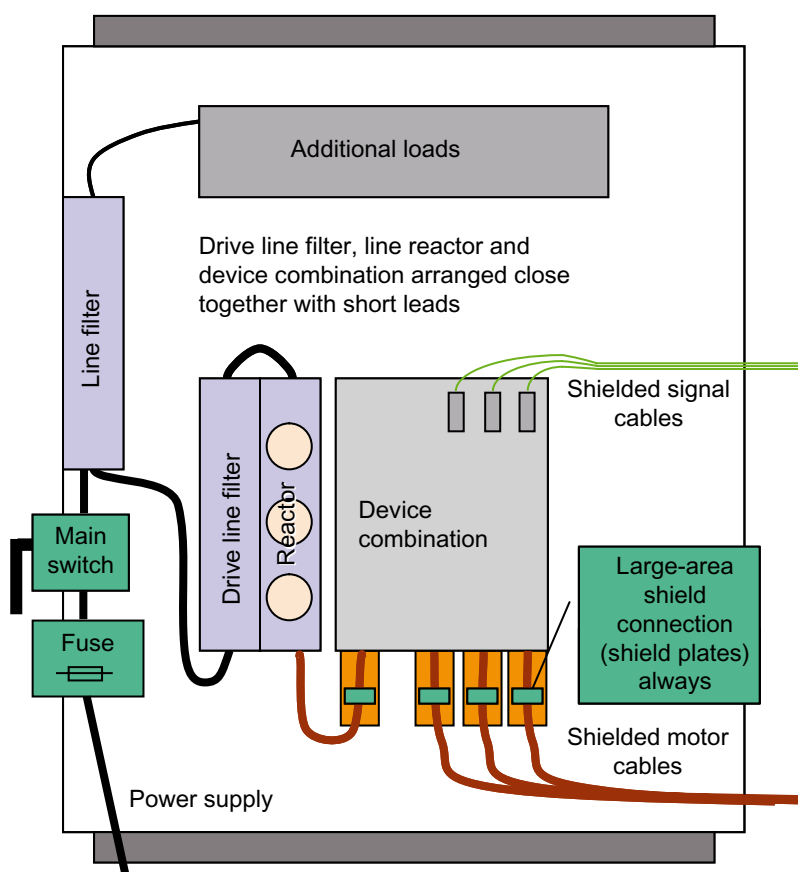

Figure 3-1 Arrangement in accordance with EMC rules (shown without cooling)

Shields of cables exiting the cabinet should be additionally attached at the cabinet entry point in order to further reduce emitted interference (radiated emission).

Further information should be taken from the "SINUMERIK, SIROTEC, SIMODRIVE, SIMOTION, SINAMICS S120 EMC Installation Guideline", order number 6FC5297-0AD30-0BP2.

3.2 Arrangement of line filter, line reactor, infeed

The housings of the line filter, line reactor and infeed for the device combination must be connected with low impedance (low resistance and low inductance) to the cabinet ground for high-frequency interference currents and the ground in turn must have a low-impedance connection to the motors/machine. For this purpose the components must be mounted close together on a common galvanized mounting plate, to which they must have a large-area, permanent conductive connection. In turn, the connection between the mounting plate and the motors/machine must be electrically conductive and have a large surface area.

Coated cabinet walls or mounting plates and DIN rails, or similar mounting means with a small contact area, do not meet this requirement.

If mounting plates are connected to each other, the connection must be close to the signal or power cables (minimizing the enclosed area).

As the line reactors can become very hot, sufficient clearance of about 100 mm must be maintained in order to prevent overheating.

3.3 Shielded cables

All cables laid from the line filter of the drive line-up to the motor must be shielded without interruption and twisted. Connections of less than 1 m may be twisted but without a shield.

Signal cables, including shielded cables, must be spatially separated from power cables. A spacing of > 0.2 m has proved successful.

All cables inside the cabinet must be connected as closely as possible to parts connected (grounded) to the cabinet ground, such as a mounting plate or cabinet wall, in order to reduce crosstalk.

Cable shields must be attached on a large area at both ends, if possible with spring-loaded elements, in order to keep to the EMC limit values. The shield connections provided must be used on the power units / motor modules.

If not, sporadic faults must be expected.

3.3.1 Examples of shield connections

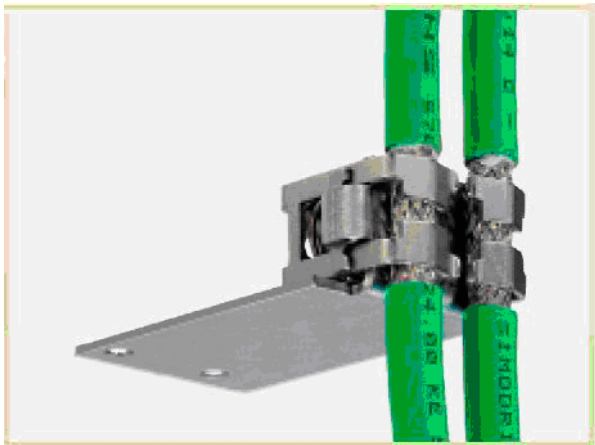

Good shield connection

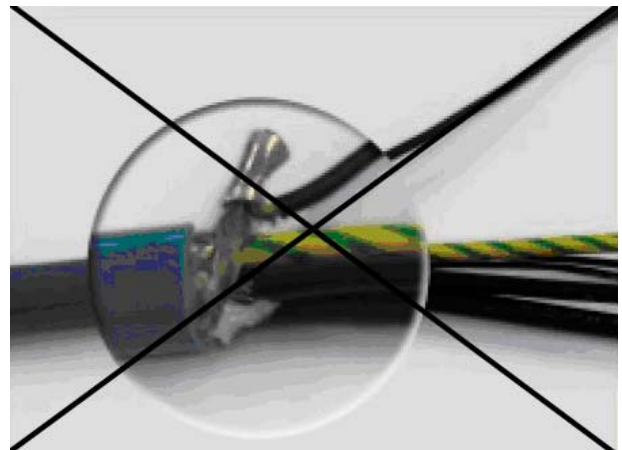

Poor shield connection

Examples of good types of shield connection

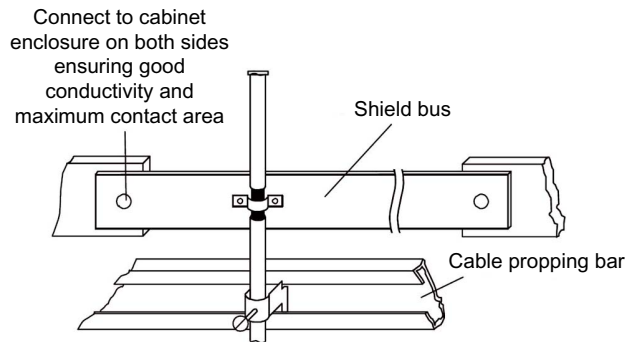

Shield bus

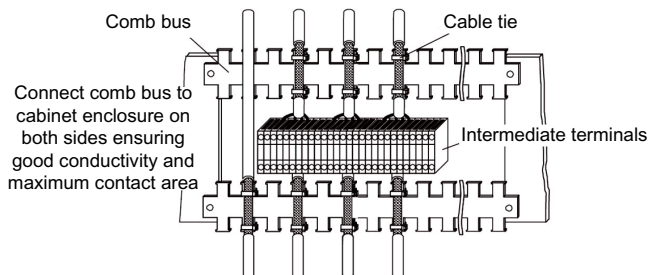

Comb bus

3.3.2 Plug connections

If cable shields are connected via connector enclosures, continuous metallic contact must be ensured. Metalized plastic is not suitable for providing sufficient contact for the length of the service life of the system because the metallic coating will be abraded by vibrations or eroded by the shield current. Alternatively the shield should be connected as described in the section headed "Shielded cables".

3.3.3 Cable lengths

Shield currents cause additional losses in the line filter, line reactor, infeed module and power units/motor modules. If the permissible cable length is exceeded, components will overheat, resulting in failures or a reduction in service life.

Up to 50 m of shielded motor cable per power unit/motor module and 150 m total cable length are permissible with SIMODRIVE 611 and SINAMICS S120 booksize. Further details about maximum cable lengths can be taken from the device-specific technical user documentation.

Leakproofness of the cabinet

A control cabinet that is closed in operation with closed cabinet doors and sealed bushings is necessary in order to ensure the following protection:

- **Protection against overheating**
Air circulation in the cabinet is influenced by open cabinet doors. This can lead to hot spots and overheating at particular points because of air short-circuits.
- **Protection against electric shock**
Unless cabinets are installed in separate electrical operating areas, it must be impossible to open them in operation except with a key or tool.
- **Protection against the spread of fire**
The spreading of fire is only safely prevented when the cabinet is closed.
- **Protection against the propagation of arcs**
The propagation of arcs is only prevented when the cabinet is closed.
- **Protection against soiling**
Soiling considerably reduces the cooling effect of internal heat sinks and fans, resulting in a reduced service life, including that of the fans. Electrically conductive soiling can also destroy insulation inside the equipment, leading to hardware failure or causing fire.
- **Protection against moisture**
Moisture can constantly enter the cabinet through open doors or impermissible apertures. If humidity is too high or condensation forms, equipment failure will occur.
- **Protection against exceeding EMC limit values**
In order to ensure compliance with the required limit values for interference immunity and emitted interference, the cabinet must be closed when in operation. If not, malfunctions must be expected.
For further information see the section headed "Arrangement of components in the cabinet".

4.1 Example of openings

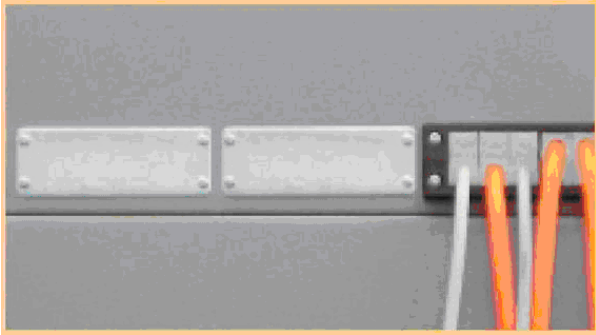

Carefully closed opening

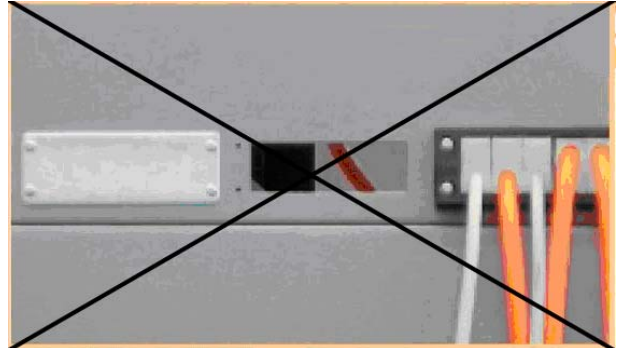

Impermissible opening

4.2 Air-to-water heat exchanger, water-cooled components

When air-to-water heat exchangers, water-to-water heat exchangers or directly water-cooled components are used, it must be ensured that no water can enter the electrical installation space during operation or in the course of maintenance and repair work.

Provision must be made to prevent condensation and to drain off condensate.

4.3 External cooling, cold plate

The ventilation clearances for the device combination inside the cabinet and above and below the heat sinks passing through the wall when using external cooling must be maintained as described in the section headed "Ventilation clearances".

The reduced heat loss that still occurs in the cabinet must be kept under control by air circulation, filter fans or cooling units.

Fans must not draw in any air contaminated with cooling lubricant nor must they be sprayed with cooling lubricant, as this will considerably reduce their service life because of them sticking and cooling ducts can become clogged.

For further information refer to the device-specific technical user documentation.

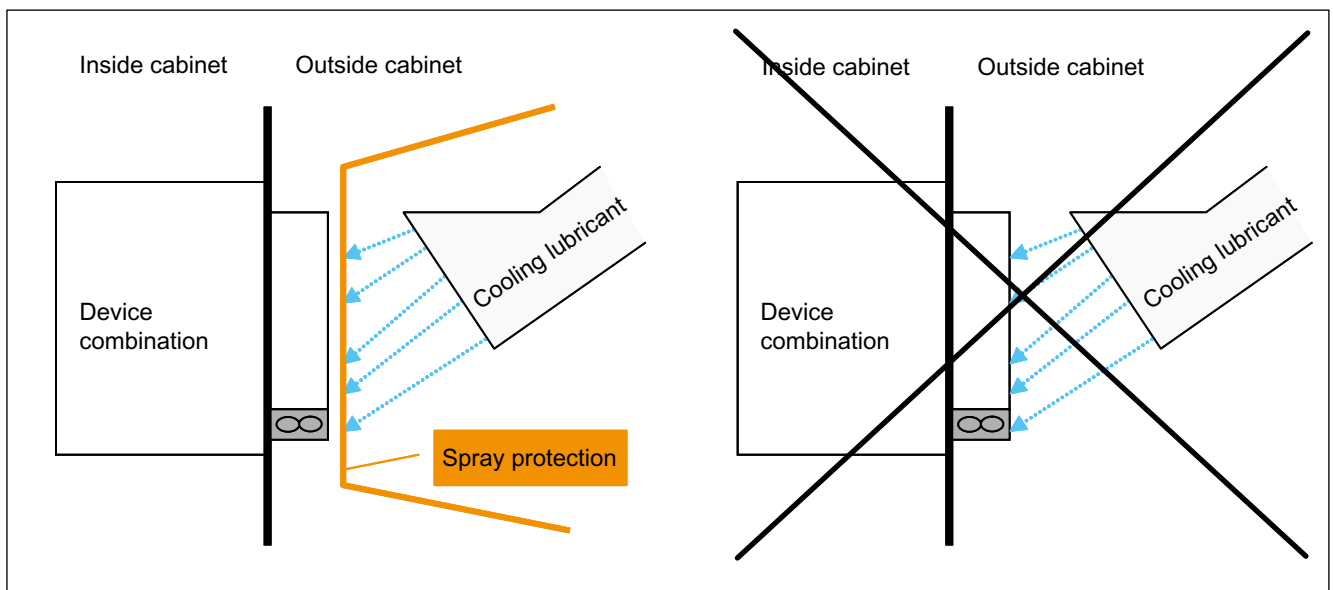

Figure 4-1 Spray protection for external cooling

Line connection

The following is needed in order to protect against electric shock and prevent fire:

5.1 Protection

It is recommended that circuit-breakers should be used, for example from the 3RV or 3VL series. Circuit-breakers largely ensure adequate protection in the event of a fault regardless of system impedances, types of grounding or loop resistances.

If isolating transformers are used, the primary and secondary side of the transformer must have all-pole fusing.

If fuses are used, the operator must ensure that the short-circuit power of the supply system at the connecting point must be at least one hundred times the nominal capacity of the equipment and the loop impedance is sufficiently low to ensure sufficiently fast tripping of the fuses. For guide values see the graph below:

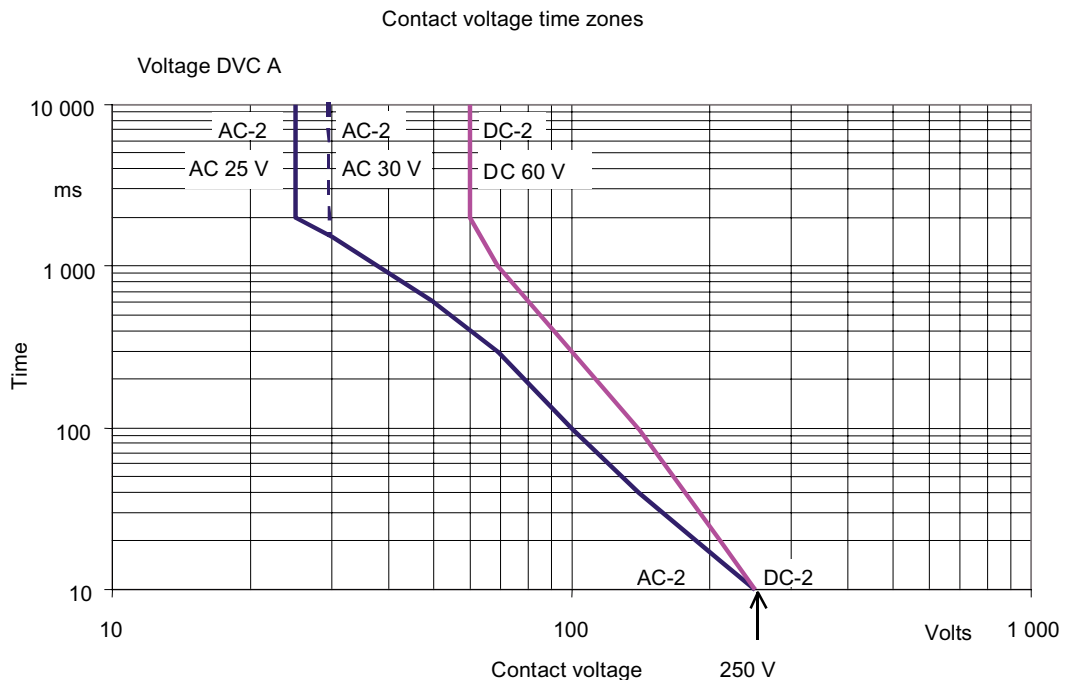

Figure 5-1 "Time v. contact voltage" graph from IEC 61800-5-1 Ed. 2, 2007

5.2 Protective conductor, protective bonding

Sufficiently low-ohm loop impedance is required for the protective conductor and the protective bonding. The protective bonding connections inside the cabinet must be dimensioned in accordance with IEC 60204-1 or IEC 618100-5-1, for example. In order to keep control over the leakage currents, either two parallel protective bonding connections or at least 10 mm² must be provided.

The operator must ensure there is a sufficiently low resistance external protective conductor inside the installation. Refer also to the section headed "Protection".

Miscellaneous

6.1 Setting controls

Setting controls must be set before switching on according to the instructions in the technical user documentation.

Examples of these are: voltage selector, mode selector switch

6.2 Screwed connections of current-conducting parts

Screwed connections of current-conducting parts (e.g. DC link motor connections, busbars) must be checked at regular intervals. The following tightening torques apply:

Screw diameter	Tightening torque
M3	0.8 Nm
M4	1.8 Nm
M5	3.0 Nm
M6	6.0 Nm
M8	13.0 Nm
M10	25.0 Nm
M12	50.0 Nm

Tolerance → 0 / 30 %

Failure to adhere to these figures can lead to fire or arcing.

6.3 External fans

When using external fans it is essential to check the direction of air flow and the correct direction of rotation. Otherwise significantly higher temperatures must be expected inside the components, leading to failures and considerably shorter service life.

6.4 Examples



Configuration switches

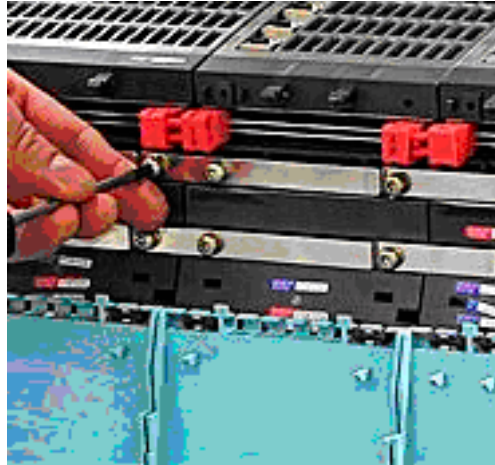

Screwed connections

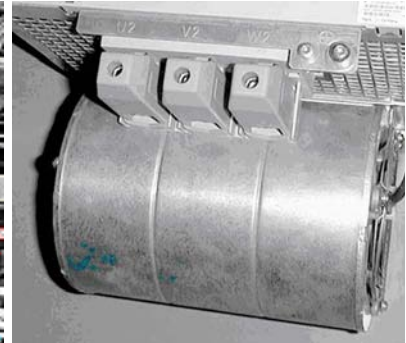

External fan

Operator controls and control panels

When installing operating devices and control panels, pay particular attention to good all-round contact with metallic assembly frames by tightening the fastening elements with the torques indicated in the product documentation.

If the air contains oil or if the unit is likely to be sprayed by cooling lubricant, make sure the seal is carefully fitted.



Figure 7-1 Example of a control unit

If the operating devices and control panels are movable, a mechanically rigid design is required. Buffers to cushion impacts are required at the stops. Failure to comply is likely to result in reduced service life for keys, displays and hard disks.



Figure 7-2 Example of a movable control unit

Wearing parts, maintenance

In a complex system there is a need for maintenance work and wearing parts have to be replaced.

Typical examples include:

Changing the filter on the cooling unit, fans, motor bearings, transducers, hard disks, backlights of displays.

It is recommended to keep a record of cyclical maintenance on the control cabinet.

Fields of application for cabinet cooling devices

(Excerpt by way of an example from the RITTAL GmbH & Co. KG product range)

Table 9-1 Fields of application for means of cooling control cabinets

	Heat loss to be dissipated $\Delta T = 10 \text{ K}$		T_{ambient} in °C			Air quality			
	< 1500 W	> 1500 W	20...55	20...70	> 70	Dust free	Dusty	Oily	Aggressive
Filter fan	X	(X)	X			X	X		
Microfilter mat (random-fiber nonwoven)	X	X	X				X		
Filter mat (random-fiber nonwoven)	X	X	X				X		
Air-to-air HE	X		X			X	X		
Air-to-water HE									
Standard	X	X	X	X	X	X	X	X	X
High-grade steel finish	X	X	X	X	X	X	X	X	X
Cooling unit									
Standard	X	X	X			X			
Chemical finish	X	X	X						X
Filter mat (open-cell PU foam)	X	X	X				X		
Metal filter	X	X	X				X	X	X
Condenser plates with nano coating	X	X	X				X	X	X

If you come across any misprints in this document, please let us know using this form. We would also be grateful for any suggestions and recommendations for improvement.

To SIEMENS AG A&D MC MS1 P.O. Box 3180 D-91050 Erlangen, Germany Fax: +49 (0) 9131 / 98 - 63315 (documentation) mailto:docu.motioncontrol@siemens.com http://www.siemens.com/automation/service&support	From Name:
	Address of your company/Dept.
	Street:
	Postal code: City:
	Phone: /
	Fax: /

Suggestions and/or corrections

Index

A

Air baffle plates, 19
Air circulation, 14, 15
Air flow rate, 15
Air guidance, 14
Air quality, 39
Arcs, 27

C

Cable installation, 22
Cable lengths, 26
Cables, 25
Circuit-breaker, 31
Clearance, 19
Condensate formation, 19
Condensation, 19
Control elements, 35
Cooling, 29
Cooling air, 15
Cooling means, 39
Cooling units, 14

D

Direction of air flow, 15
Dirt and contamination, 27
Draining condensate, 19

E

Electric shock, 27
External fans, 33

F

Fire, 27

H

Humidity, 19

I

Isolating transformer, 31

L

Line filter, 24
Line reactor, 24

M

Moisture, 27

O

Operator panels, 35
Overheating, 27

S

Screwed connections, 33
Setting controls, 33
Shield connection, 25

T

Temperature setting, 20

V

Ventilation clearances, 21
Ventilation grille, 22

W

Wall-mounted cooling units, 16
Water-cooled components, 28
Wearing parts, 37

Siemens AG

Automation and Drives
Motion Control Systems
Postfach 3180
91050 ERLANGEN
GERMANY

www.siemens.com/motioncontrol

6SL3097-0AT00-0BP0