



SENTRON, Switch disconnecter 3LD, main switch, 3-pole, Iu: 32 A, Operating power / at AC-23 A at 400 V: 11.5 kW, molded-plastic encapsulation for metric screw connection, 1 NC, 1 NO, rotary operating mechanism, black

Model	
product brand name	SENTRON
product designation	3LD Switch disconnecter
design of the product	Main switch
display version for switch position indicator manual operation	1 ON - 0 OFF
type of switch	Molded-plastic enclosure for metric threaded joint
design of the actuating element	Short rotary knob
color of the actuating element	black
design of handle	rotary operating mechanism, black
type of the driving mechanism motor drive	No
General technical data	
number of poles	3
number of poles note	N
size of switch disconnecter	2
mechanical service life (operating cycles) typical	100 000
electrical endurance (operating cycles)	
• at AC-23 A at 690 V	6 000
operating frequency maximum	50 1/h
degree of pollution	3
Voltage	
insulation voltage rated value	690 V
surge voltage resistance rated value	6 kV
operating voltage	
• at AC rated value	690 V
operating frequency rated value	
• minimum	50 Hz
• maximum	60 Hz
Protection class	
protection class IP	IP65
degree of protection NEMA rating	1, 4X, 12
protection class IP on the front	IP65
Dissipation	
power loss [W] for rated value of the current at AC in hot operating state per pole	1.8 W
Main circuit	
operational current	
• at AC-21 at 690 V rated value	32 A
• at AC-21 A at 240 V rated value	32 A
• at AC-21 A at 400 V rated value	32 A
• at AC-21 A at 440 V rated value	32 A

<ul style="list-style-type: none"> <li>at AC-23 A at 400 V rated value</li> </ul>	22 A
operating power	
<ul style="list-style-type: none"> <li>at AC-23 A at 240 V rated value</li> </ul>	6 kW
<ul style="list-style-type: none"> <li>at AC-23 A at 400 V rated value</li> </ul>	12 kW
<ul style="list-style-type: none"> <li>at AC-23 A at 440 V rated value</li> </ul>	11.5 kW
<ul style="list-style-type: none"> <li>at AC-23 A at 690 V rated value</li> </ul>	12 kW
<ul style="list-style-type: none"> <li>at AC-3 at 240 V rated value</li> </ul>	5.5 kW
<ul style="list-style-type: none"> <li>at AC-3 at 400 V rated value</li> </ul>	10 kW
<ul style="list-style-type: none"> <li>at AC-3 at 690 V rated value</li> </ul>	9.5 kW
<b>Auxiliary circuit</b>	
number of CO contacts for auxiliary contacts	0
number of NC contacts for auxiliary contacts	1
number of NO contacts for auxiliary contacts	1
operating voltage of auxiliary contacts at AC maximum	500 V
continuous current of the auxiliary contact rated value	10 A
insulation voltage of the auxiliary switch rated value	500 V
<b>Suitability</b>	
suitability for use	
<ul style="list-style-type: none"> <li>main switch</li> </ul>	Yes
<ul style="list-style-type: none"> <li>switch disconnecter</li> </ul>	Yes
<ul style="list-style-type: none"> <li>EMERGENCY OFF switch</li> </ul>	No
<ul style="list-style-type: none"> <li>safety switch</li> </ul>	Yes
<ul style="list-style-type: none"> <li>maintenance/repair switch</li> </ul>	Yes
<b>Product details</b>	
product feature can be locked into OFF position	Yes
<b>accessories</b>	
product extension optional	
<ul style="list-style-type: none"> <li>motor drive</li> </ul>	No
<ul style="list-style-type: none"> <li>voltage trigger</li> </ul>	No
number of connectable NC contacts for auxiliary contacts attachable maximum	2
number of connectable NO contacts for auxiliary contacts attachable maximum	3
number of connectable CO contacts for auxiliary contacts attachable maximum	0
number of bracket locks maximum	3
hasp thickness of the bracket locks	4 ... 8 mm
<b>Short circuit</b>	
conditional short-circuit current with line-side fuse protection	
<ul style="list-style-type: none"> <li>at 690 V by gG fuse rated value</li> </ul>	50 kA
let-through current with closed switch	
<ul style="list-style-type: none"> <li>at 240 V for combination switch + gG fuse maximum</li> </ul>	4.5 kA
<ul style="list-style-type: none"> <li>at 440 V for combination switch + gG fuse maximum</li> </ul>	4.5 kA
<ul style="list-style-type: none"> <li>at 690 V for combination switch + gG fuse maximum permissible</li> </ul>	5 kA
I <sup>2</sup> t value with closed switch	
<ul style="list-style-type: none"> <li>at 240 V for combination switch + gG fuse maximum</li> </ul>	9 kA <sup>2</sup> .s
<ul style="list-style-type: none"> <li>at 440 V for combination switch + gG fuse maximum</li> </ul>	9 kA <sup>2</sup> .s
<ul style="list-style-type: none"> <li>at 690 V for combination switch + gG fuse maximum</li> </ul>	9 kA <sup>2</sup> .s
design of the fuse link	
<ul style="list-style-type: none"> <li>for short-circuit protection of the main circuit required</li> </ul>	fuse gL/gG: 40 A
<ul style="list-style-type: none"> <li>for short-circuit protection of the auxiliary switch required</li> </ul>	fuse gL/gG: 10 A
operational current of upstream fuse rated value	40 A
<b>according UL</b>	
operational current at AC according to UL 508/UL 60947-4-1 rated value	32 A
operating voltage at AC at 50/60 Hz according to UL 508/UL 60947-4-1 rated value	600 V
active power [hp] at AC at 480 V according to UL 508/UL 60947-4-1 rated value	20
active power [hp] at AC at 600 V according to UL 508/UL	20

60947-4-1 rated value	
short-time withstand current (SCCR) at 600 V according to UL 508/UL 60947-4-1	5 kA
continuous current of upstream fuse according to UL rated value	80 A
type of fuse according to UL	RK5

### Connections

AWG number as coded connectable conductor cross section solid	
<ul style="list-style-type: none"> <li>• maximum</li> <li>• minimum</li> </ul>	8 14
type of connectable conductor cross-sections for copper conductor	
<ul style="list-style-type: none"> <li>• solid</li> <li>• finely stranded with core end processing</li> <li>• stranded</li> </ul>	1x (1,5...16mm <sup>2</sup> ) 1x (1,5...10mm <sup>2</sup> ) 1x (1,5...16mm <sup>2</sup> )
type of connectable conductor cross-sections for auxiliary contacts	
<ul style="list-style-type: none"> <li>• solid</li> <li>• finely stranded with core end processing</li> <li>• stranded</li> </ul>	lateral auxiliary switch 2x (0,75 ... 2,5mm <sup>2</sup> ), 1x 4mm <sup>2</sup> ; front auxiliary switch 1x (0,75 ... 2,5mm <sup>2</sup> ) lateral auxiliary switch 2x (0,75 ... 1,5mm <sup>2</sup> ), 1x 2,5mm <sup>2</sup> ; front auxiliary switch 1x 2,5mm <sup>2</sup> lateral auxiliary switch 2x (0,75 ... 2,5mm <sup>2</sup> ), 1x 4mm <sup>2</sup> ; front auxiliary switch 1x (0,75 ... 2,5mm <sup>2</sup> )
type of electrical connection	
<ul style="list-style-type: none"> <li>• for main current circuit</li> <li>• for auxiliary contacts</li> </ul>	box terminal connection terminals

### Mechanical Design

height	152 mm
width	100 mm
depth	117 mm
type of device	fixed mounting
fastening method	Complete unit in enclosure
fastening method	
<ul style="list-style-type: none"> <li>• 4-hole front mounting</li> <li>• front mounting with central attachment</li> <li>• rail mounting</li> </ul>	No Yes No
net weight	477 g

### Environmental conditions

ambient temperature during operation	
<ul style="list-style-type: none"> <li>• minimum</li> <li>• maximum</li> </ul>	-25 °C 55 °C
ambient temperature during storage	
<ul style="list-style-type: none"> <li>• minimum</li> <li>• maximum</li> </ul>	-25 °C 55 °C

### General Product Approval



[Confirmation](#)



[Miscellaneous](#)

General Product Approval

Declaration of Conformity

Test Certificates



EG-Konf.



[Special Test Certificate](#)

[Miscellaneous](#)

[Miscellaneous](#)

Marine / Shipping

other

Environment

Further information

**Siemens has decided to exit the Russian market (see here).**

<https://press.siemens.com/global/en/pressrelease/siemens-wind-down-russian-business>

**Siemens is working on the renewal of the current EAC certificates.**

Please contact your local Siemens office on the status of validity of the EAC certification if you intend to import or offer to supply these products to an EAC relevant market (other than the sanctioned EAEU member states Russia or Belarus).

**Information on the packaging**

<https://support.industry.siemens.com/cs/ww/en/view/109813875>

**Information- and Downloadcenter (Catalogs, Brochures,...)**

<http://www.siemens.com/lowvoltage/catalogs>

**Industry Mall (Online ordering system)**

<https://mall.industry.siemens.com/mall/en/en/Catalog/product?mlfb=3LD2264-1GP51>

**Service&Support (Manuals, Certificates, Characteristics, FAQs,...)**

<https://support.industry.siemens.com/cs/ww/en/ps/3LD2264-1GP51>

**Image database (product images, 2D dimension drawings, 3D models, device circuit diagrams, ...)**

[http://www.automation.siemens.com/bilddb/cax\\_en.aspx?mlfb=3LD2264-1GP51](http://www.automation.siemens.com/bilddb/cax_en.aspx?mlfb=3LD2264-1GP51)

**CAX-Online-Generator**

<http://www.siemens.com/cax>

**Tender specifications**

<http://www.siemens.com/specifications>

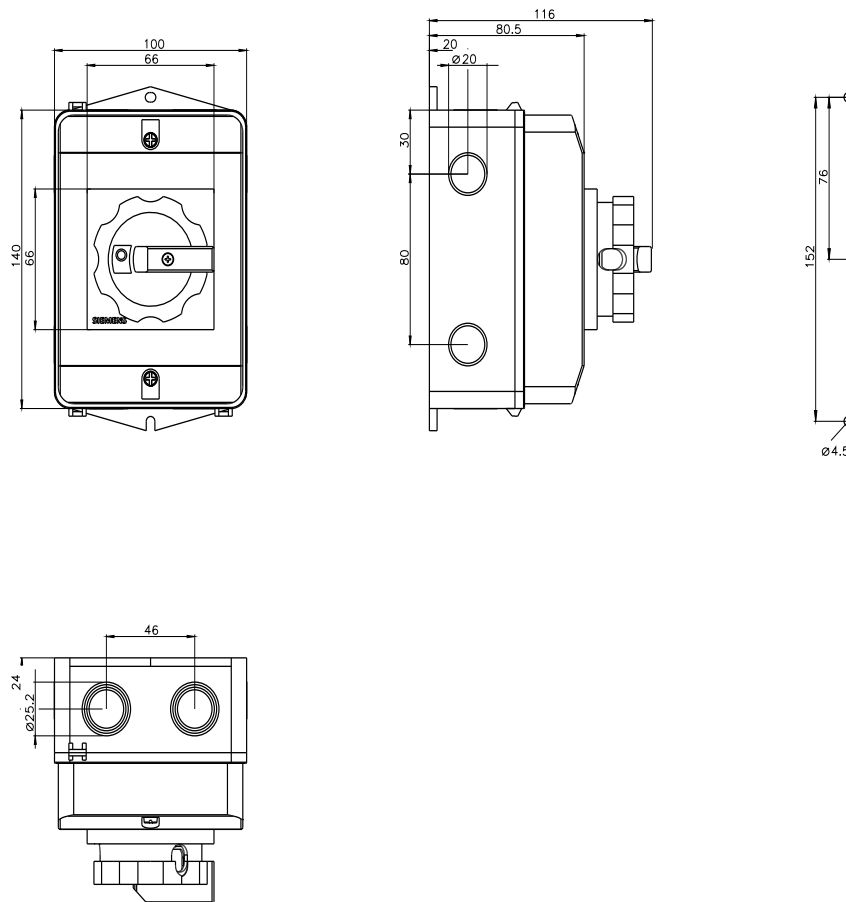

**-Q1**

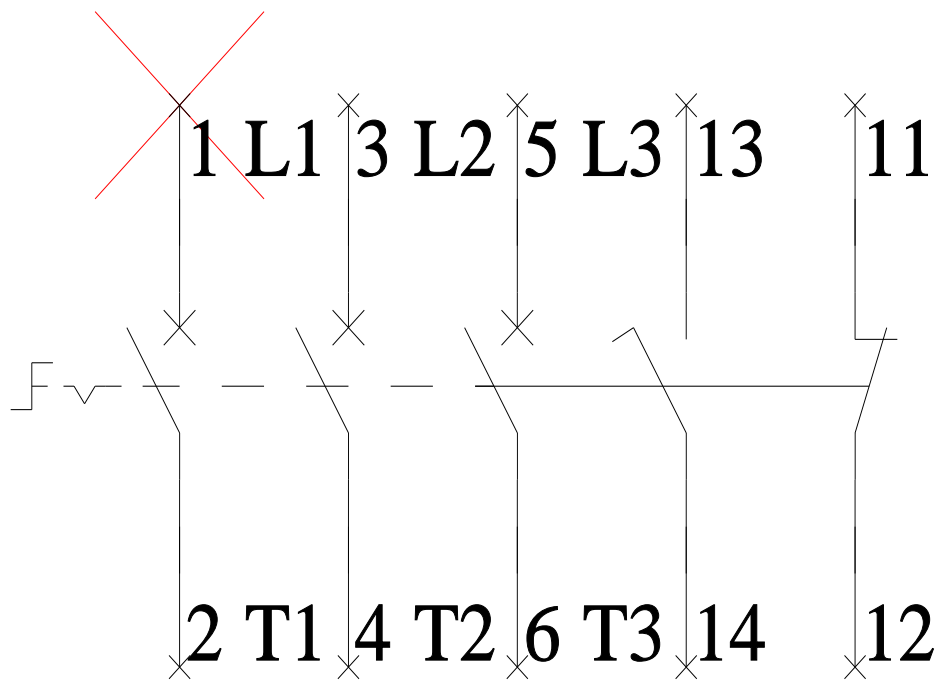

**-CI**

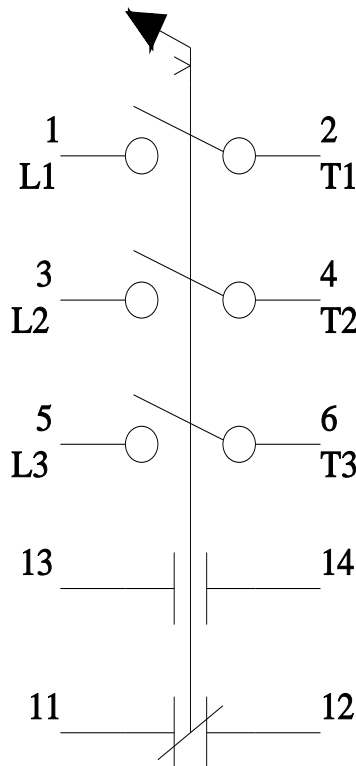

last modified:

4/28/2022

