



Circuit breaker size S00 for motor protection, CLASS 10 A-release 3.5...5 A
N release 65 A screw terminal Standard switching capacity

product brand name	SIRIUS
product designation	Circuit breaker
design of the product	For motor protection
product type designation	3RV2

General technical data

size of the circuit-breaker	S00
size of contactor can be combined company-specific	S00, S0
product extension auxiliary switch	Yes
power loss [W] for rated value of the current	
• at AC in hot operating state	7.25 W
• at AC in hot operating state per pole	2.4 W
insulation voltage with degree of pollution 3 at AC rated value	690 V
surge voltage resistance rated value	6 kV
shock resistance according to IEC 60068-2-27	25g / 11 ms
mechanical service life (operating cycles)	
• of the main contacts typical	100 000
• of auxiliary contacts typical	100 000
electrical endurance (operating cycles) typical	100 000
type of protection according to ATEX directive 2014/34/EU	Ex II (2) GD
certificate of suitability according to ATEX directive 2014/34/EU	DMT 02 ATEX F 001
reference code according to IEC 81346-2	Q
Substance Prohibitance (Date)	10/01/2009

Ambient conditions

installation altitude at height above sea level maximum	2 000 m
ambient temperature	
• during operation	-20 ... +60 °C
• during storage	-50 ... +80 °C
• during transport	-50 ... +80 °C
relative humidity during operation	10 ... 95 %

Main circuit

number of poles for main current circuit	3
adjustable current response value current of the current-dependent overload release	3.5 ... 5 A
operating voltage	
• rated value	20 ... 690 V
• at AC-3 rated value maximum	690 V
• at AC-3e rated value maximum	690 V
operating frequency rated value	50 ... 60 Hz
operational current rated value	5 A

operational current	
• at AC-3 at 400 V rated value	5 A
• at AC-3e at 400 V rated value	5 A
operating power	
• at AC-3	
— at 230 V rated value	1.1 kW
— at 400 V rated value	1.5 kW
— at 500 V rated value	2.2 kW
— at 690 V rated value	4 kW
• at AC-3e	
— at 230 V rated value	1.1 kW
— at 400 V rated value	1.5 kW
— at 500 V rated value	2.2 kW
— at 690 V rated value	4 kW
operating frequency	
• at AC-3 maximum	15 1/h
• at AC-3e maximum	15 1/h

Auxiliary circuit

number of NC contacts for auxiliary contacts	0
number of NO contacts for auxiliary contacts	0
number of CO contacts for auxiliary contacts	0

Protective and monitoring functions

product function	
• ground fault detection	No
• phase failure detection	Yes
trip class	CLASS 10
design of the overload release	thermal
maximum short-circuit current breaking capacity (Icu)	
• at AC at 240 V rated value	100 kA
• at AC at 400 V rated value	100 kA
• at AC at 500 V rated value	100 kA
• at AC at 690 V rated value	6 kA
operating short-circuit current breaking capacity (Ics) at AC	
• at 240 V rated value	100 kA
• at 400 V rated value	100 kA
• at 500 V rated value	100 kA
• at 690 V rated value	4 kA
response value current of instantaneous short-circuit trip unit	65 A

UL/CSA ratings

full-load current (FLA) for 3-phase AC motor	
• at 480 V rated value	5 A
• at 600 V rated value	5 A
yielded mechanical performance [hp]	
• for single-phase AC motor	
— at 110/120 V rated value	0.17 hp
— at 230 V rated value	0.5 hp
• for 3-phase AC motor	
— at 200/208 V rated value	1 hp
— at 220/230 V rated value	1 hp
— at 460/480 V rated value	3 hp
— at 575/600 V rated value	3 hp

Short-circuit protection

product function short circuit protection	Yes
design of the short-circuit trip	magnetic
design of the fuse link for IT network for short-circuit protection of the main circuit	
• at 400 V	gL/gG 32 A
• at 500 V	gL/gG 32 A
• at 690 V	gL/gG 25 A

Installation/ mounting/ dimensions

mounting position	any
--------------------------	-----

fastening method	screw and snap-on mounting onto 35 mm DIN rail according to DIN EN 60715
height	97 mm
width	45 mm
depth	97 mm
required spacing	0 mm
<ul style="list-style-type: none"> • with side-by-side mounting at the side • for grounded parts at 400 V <ul style="list-style-type: none"> — downwards 30 mm — upwards 30 mm — at the side 9 mm • for live parts at 400 V <ul style="list-style-type: none"> — downwards 30 mm — upwards 30 mm — at the side 9 mm • for grounded parts at 500 V <ul style="list-style-type: none"> — downwards 30 mm — upwards 30 mm — at the side 9 mm • for live parts at 500 V <ul style="list-style-type: none"> — downwards 30 mm — upwards 30 mm — at the side 9 mm • for grounded parts at 690 V <ul style="list-style-type: none"> — downwards 50 mm — upwards 50 mm — backwards 0 mm — at the side 30 mm — forwards 0 mm • for live parts at 690 V <ul style="list-style-type: none"> — downwards 50 mm — upwards 50 mm — backwards 0 mm — at the side 30 mm — forwards 0 mm 	

Connections/ Terminals

type of electrical connection	screw-type terminals
<ul style="list-style-type: none"> • for main current circuit 	Top and bottom
arrangement of electrical connectors for main current circuit	
type of connectable conductor cross-sections	
<ul style="list-style-type: none"> • for main contacts <ul style="list-style-type: none"> — solid or stranded 2x (0,75 ... 2,5 mm²), 2x 4 mm² — finely stranded with core end processing 2x (0,5 ... 1,5 mm²), 2x (0,75 ... 2,5 mm²) • at AWG cables for main contacts 2x (18 ... 14), 2x 12 	
tightening torque	0.8 ... 1.2 N·m
<ul style="list-style-type: none"> • for main contacts with screw-type terminals 	Diameter 5 to 6 mm
design of screwdriver shaft	Pozidriv size 2
size of the screwdriver tip	
design of the thread of the connection screw	
<ul style="list-style-type: none"> • for main contacts 	M3

Safety related data

B10 value	5 000
<ul style="list-style-type: none"> • with high demand rate according to SN 31920 	
proportion of dangerous failures	50 %
<ul style="list-style-type: none"> • with low demand rate according to SN 31920 • with high demand rate according to SN 31920 	50 %
failure rate [FIT]	50 FIT
<ul style="list-style-type: none"> • with low demand rate according to SN 31920 	10 a
T1 value for proof test interval or service life according to IEC 61508	
protection class IP on the front according to IEC 60529	IP20
touch protection on the front according to IEC 60529	finger-safe, for vertical contact from the front

Certificates/ approvals

General Product Approval

For use in hazardous locations

[Confirmation](#)

CCC



UL

[KC](#)

IECEX

For use in hazardous locations

Declaration of Conformity

Test Certificates

Marine / Shipping



ATEX



EG-Konf.

[Type Test Certificates/Test Report](#)[Special Test Certificate](#)

ABS

Marine / Shipping

other

BUREAU
VERITAS

DNV



LRS



PRS



RINA

[Confirmation](#)

other

Railway



VDE

[Vibration and Shock](#)[Confirmation](#)

Further information

Siemens has decided to exit the Russian market (see here).

<https://press.siemens.com/global/en/pressrelease/siemens-wind-down-russian-business>

Siemens is working on the renewal of the current EAC certificates.

Please contact your local Siemens office on the status of validity of the EAC certification if you intend to import or offer to supply these products to an EAC relevant market (other than the sanctioned EAEU member states Russia or Belarus).

Information on the packaging

<https://support.industry.siemens.com/cs/ww/en/view/109813875>

Information- and Downloadcenter (Catalogs, Brochures,...)

<https://www.siemens.com/ic10>

Industry Mall (Online ordering system)

<https://mall.industry.siemens.com/mall/en/en/Catalog/product?mlfb=3RV2011-1FA10>

Cax online generator

<http://support.automation.siemens.com/WW/CAXorder/default.aspx?lang=en&mlfb=3RV2011-1FA10>

Service&Support (Manuals, Certificates, Characteristics, FAQs,...)

<https://support.industry.siemens.com/cs/ww/en/ps/3RV2011-1FA10>

Image database (product images, 2D dimension drawings, 3D models, device circuit diagrams, EPLAN macros, ...)

http://www.automation.siemens.com/bilddb/cax_de.aspx?mlfb=3RV2011-1FA10&lang=en

Characteristic: Tripping characteristics, I_t, Let-through current

<https://support.industry.siemens.com/cs/ww/en/ps/3RV2011-1FA10/char>

Further characteristics (e.g. electrical endurance, switching frequency)

<http://www.automation.siemens.com/bilddb/index.aspx?view=Search&mlfb=3RV2011-1FA10&objecttype=14&gridview=view1>

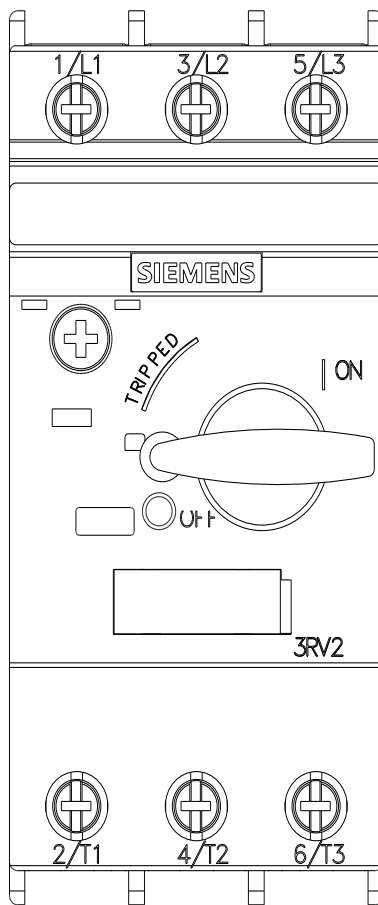



last modified:

11/21/2022 