



Solid-state contactor 3-phase 3RF2 AC 51 / 10 A / 40 °C 48-600 V / 4-30 V
DC 3-phase controlled screw terminal Blocking voltage 1200 V

product brand name	SIRIUS
product designation	solid-state contactor
design of the product	three-phase controlled
product type designation	3RF24
manufacturer's article number	
<ul style="list-style-type: none"> • _2 of the accessories that can be ordered 	3RF2900-0EA18
product designation	
<ul style="list-style-type: none"> • _2 of the accessories that can be ordered 	converter

General technical data

product function	zero-point switching
power loss [W] for rated value of the current	
<ul style="list-style-type: none"> • at AC in hot operating state • at AC in hot operating state per pole • without load current share typical 	<p>31 W</p> <p>10.33 W</p> <p>0.9 W</p>
insulation voltage rated value	600 V
degree of pollution	3
type of voltage of the control supply voltage	DC
surge voltage resistance of main circuit rated value	6 kV
shock resistance according to IEC 60068-2-27	15g / 11 ms
vibration resistance according to IEC 60068-2-6	2g
reference code according to IEC 81346-2	Q
Substance Prohibitance (Date)	07/01/2006

Main circuit

number of poles for main current circuit	3
number of NO contacts for main contacts	3
number of NC contacts for main contacts	0
operating voltage at AC	
<ul style="list-style-type: none"> • at 50 Hz rated value • at 60 Hz rated value 	<p>48 ... 600 V</p> <p>48 ... 600 V</p>
operating frequency rated value	50 ... 60 Hz
relative symmetrical tolerance of the operating frequency	10 %
operating range relative to the operating voltage at AC	
<ul style="list-style-type: none"> • at 50 Hz • at 60 Hz 	<p>40 ... 660 V</p> <p>40 ... 660 V</p>
operational current	
<ul style="list-style-type: none"> • at AC-51 rated value • at AC-51 according to IEC 60947-4-3 • according to UL 508 rated value 	<p>10.5 A</p> <p>7 A</p> <p>7 A</p>
operational current minimum	500 mA
rate of voltage rise at the thyristor for main contacts	500 V/μs
maximum permissible	

blocking voltage at the thyristor for main contacts maximum permissible	1 200 V
reverse current of the thyristor	10 mA
derating temperature	40 °C
surge current resistance rated value	300 A
I²t value maximum	450 A ² ·s
Control circuit/ Control	
type of voltage of the control supply voltage	DC
control supply voltage 1	
• at DC rated value	30 V
• at DC	4 ... 30 V
control supply voltage	
• at DC initial value for signal <1> detection	4 V
• at DC full-scale value for signal <0> recognition	1 V
symmetrical line frequency tolerance	5 Hz
control current at minimum control supply voltage	
• at DC	22 mA
control current at DC rated value	30 mA
ON-delay time	1 ms; additionally max. one half-wave
Auxiliary circuit	
number of NC contacts for auxiliary contacts	0
number of NO contacts for auxiliary contacts	0
number of CO contacts for auxiliary contacts	0
Installation/ mounting/ dimensions	
fastening method	screw fixing and snap-on mounting on standard mounting rail 35 mm according to IEC 60715
• side-by-side mounting	Yes
design of the thread of the screw for securing the equipment	M4
height	95 mm
width	45 mm
depth	96.5 mm
Connections/ Terminals	
type of electrical connection	
• for main current circuit	screw-type terminals
• for auxiliary and control circuit	screw-type terminals
type of connectable conductor cross-sections	
• for main contacts	
— solid	2x (1.5 ... 2.5 mm ²), 2x (2.5 ... 6 mm ²)
— finely stranded with core end processing	2x (1 ... 2.5 mm ²), 2x (2.5 ... 6 mm ²), 1x 10 mm ²
• at AWG cables for main contacts	2x (14 ... 10)
connectable conductor cross-section for main contacts	
• solid or stranded	1.5 ... 6 mm ²
• finely stranded with core end processing	1 ... 10 mm ²
type of connectable conductor cross-sections	
• for auxiliary and control contacts	
— solid	1x (0.5 ... 2.5 mm ²), 2x (0.5 ... 1.0 mm ²)
— finely stranded with core end processing	1x (0.5 ... 2.5 mm ²), 2x (0.5 ... 1.0 mm ²)
— finely stranded without core end processing	1x (0.5 ... 2.5 mm ²), 2x (0.5 ... 1.0 mm ²)
• at AWG cables for auxiliary and control contacts	1x (AWG 20 ... 12)
AWG number as coded connectable conductor cross section for main contacts	14 ... 10
tightening torque	
• for main contacts with screw-type terminals	2 ... 2.5 N·m
• for auxiliary and control contacts with screw-type terminals	0.5 ... 0.6 N·m
tightening torque [lbf·in]	
• for main contacts with screw-type terminals	18 ... 22 lbf·in
• for auxiliary and control contacts with screw-type terminals	7.5 ... 5.3 lbf·in
design of the thread of the connection screw	
• for main contacts	M4
• of the auxiliary and control contacts	M3

stripped length of the cable	
<ul style="list-style-type: none"> • for main contacts • for auxiliary and control contacts 	<p>7 mm</p> <p>7 mm</p>

Safety related data

protection class IP on the front according to IEC 60529	IP20
touch protection on the front according to IEC 60529	finger-safe, for vertical contact from the front

Ambient conditions

installation altitude at height above sea level maximum	1 000 m
ambient temperature	
<ul style="list-style-type: none"> • during operation • during storage 	<p>-25 ... +60 °C</p> <p>-55 ... +80 °C</p>

Electromagnetic compatibility

conducted interference	
<ul style="list-style-type: none"> • due to burst according to IEC 61000-4-4 • due to conductor-earth surge according to IEC 61000-4-5 • due to conductor-conductor surge according to IEC 61000-4-5 • due to high-frequency radiation according to IEC 61000-4-6 	<p>2 kV / 5 kHz behavior criterion 2</p> <p>2 kV behavior criterion 2</p> <p>1 kV behavior criterion 2</p> <p>140 dBuV in the frequency range 0.15 ... 80 MHz, behavior criterion 1</p>
electrostatic discharge according to IEC 61000-4-2	4 kV contact discharging / 8 kV air discharging, behavior criterion 2
conducted HF interference emissions according to CISPR11	Class A for industrial environment
field-bound HF interference emission according to CISPR11	Class A for industrial environment

Short-circuit protection, design of the fuse link

<p>manufacturer's article number</p> <ul style="list-style-type: none"> • of full range R fuse link for semiconductor protection at NH design usable • of full range R fuse link for semiconductor protection at cylindrical design usable • of back-up R fuse link for semiconductor protection at NH design usable • of back-up R fuse link for semiconductor protection at cylindrical design 10 x 38 mm usable • of back-up R fuse link for semiconductor protection at cylindrical design 14 x 51 mm usable • of back-up R fuse link for semiconductor protection at cylindrical design 22 x 58 mm usable <p>manufacturer's article number of the gG fuse at NH design usable</p> <ul style="list-style-type: none"> • up to 460 V 	<p>3NE1813-0</p> <p>5SE1310; Maximum operating voltage 400 V!</p> <p>3NE8015-1</p> <p>3NC1016</p> <p>3NC1420</p> <p>3NC2220</p> <p>3NA3801; These fuses have a smaller rated current than the semiconductor relays</p>
--	--

Certificates/ approvals

General Product Approval	EMC	Declaration of Conformity
---------------------------------	------------	----------------------------------



[Confirmation](#)



Declaration of Conformity	Test Certificates	other
----------------------------------	--------------------------	--------------



[Type Test Certificates/Test Report](#)

[Confirmation](#)



Further information

Siemens has decided to exit the Russian market (see here).

<https://press.siemens.com/global/en/pressrelease/siemens-wind-down-russian-business>

Siemens is working on the renewal of the current EAC certificates.

Please contact your local Siemens office on the status of validity of the EAC certification if you intend to import or offer to supply these products to an EAC relevant market (other than the sanctioned EAEU member states Russia or Belarus).

Information on the packaging

<https://support.industry.siemens.com/cs/ww/en/view/109813875>

Information- and Downloadcenter (Catalogs, Brochures,...)

<https://www.siemens.com/ic10>

Industry Mall (Online ordering system)

<https://mall.industry.siemens.com/mall/en/en/Catalog/product?mlfb=3RF2410-1AC45>

Cax online generator

<http://support.automation.siemens.com/WW/CAXorder/default.aspx?lang=en&mlfb=3RF2410-1AC45>

Service&Support (Manuals, Certificates, Characteristics, FAQs,...)

<https://support.industry.siemens.com/cs/ww/en/ps/3RF2410-1AC45>

Image database (product images, 2D dimension drawings, 3D models, device circuit diagrams, EPLAN macros, ...)

http://www.automation.siemens.com/bilddb/cax_de.aspx?mlfb=3RF2410-1AC45&lang=en

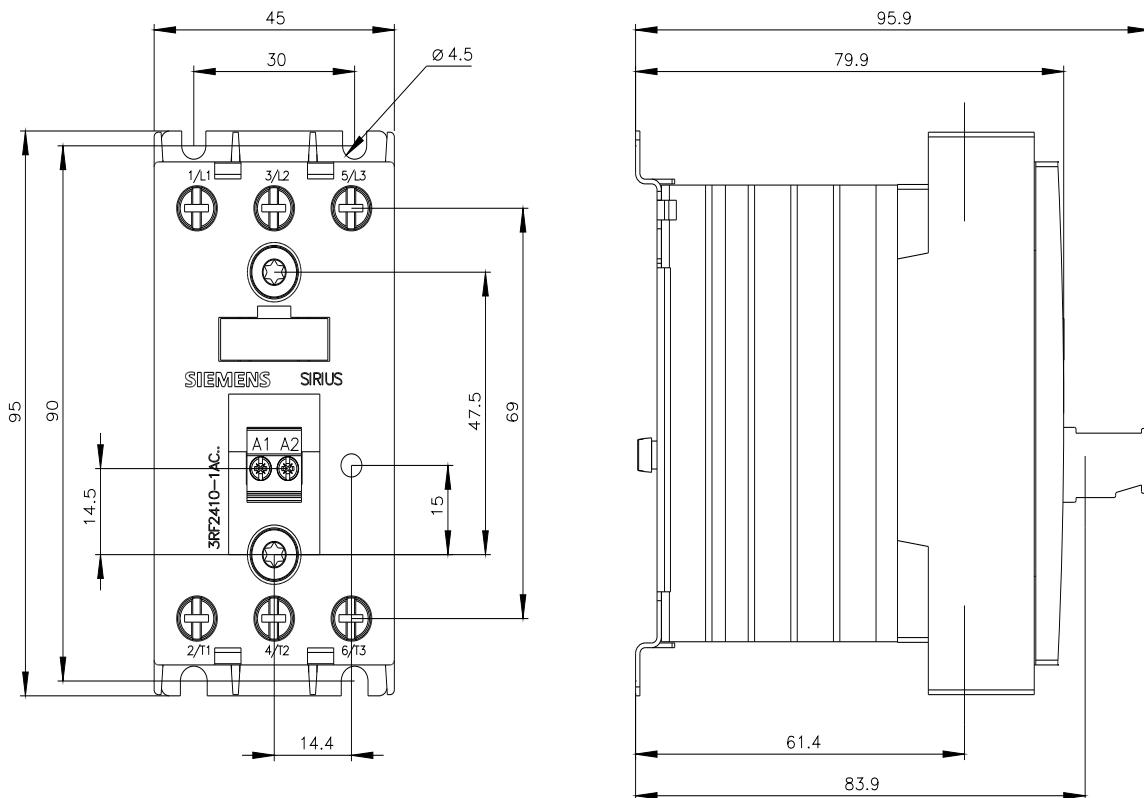

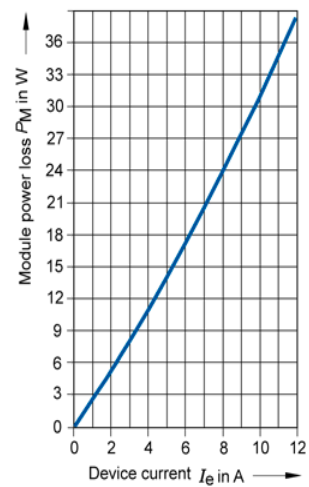
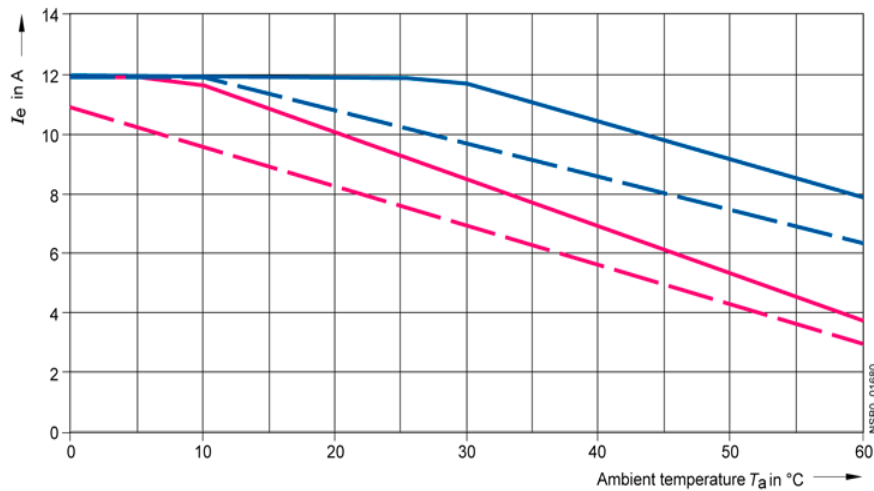
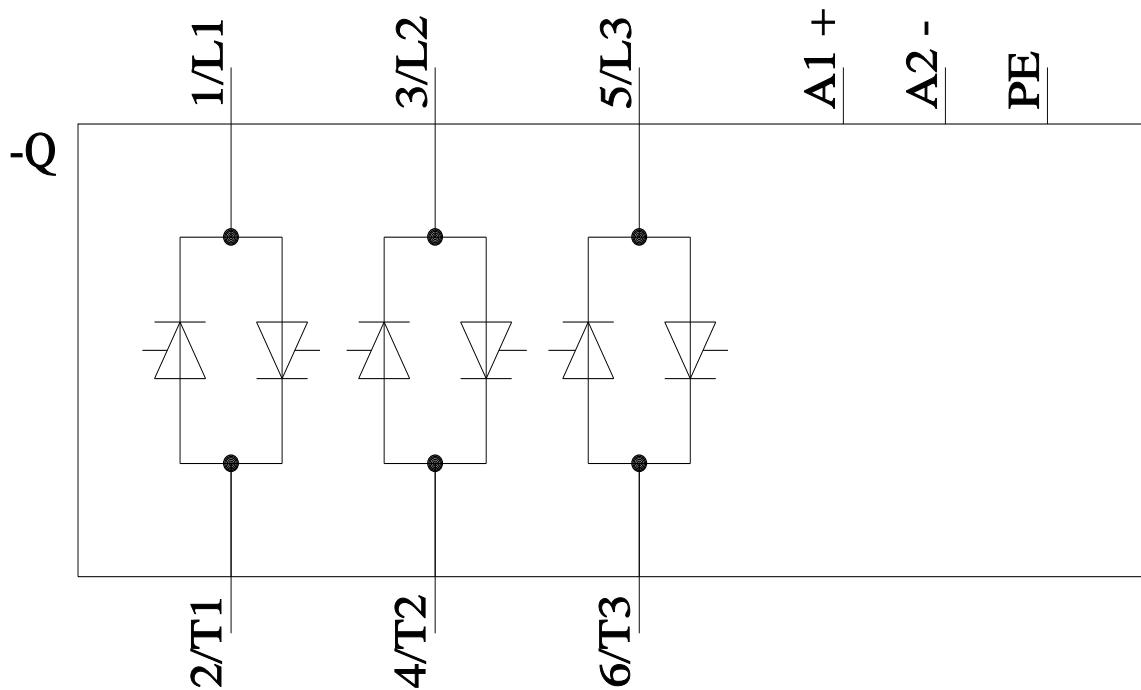

- I_{max} Thermal limit current for individual mounting
- - - I_{max} Thermal limit current for side-by-side mounting
- I_{IEC} Current according to IEC 947-4-3 for individual mounting
- - - I_{IEC} Current according to IEC 947-4-3 for side-by-side mounting

last modified:

1/26/2022