

TURCK

Industrial Automation

APPLICATION NOTE

BLxx- FUNCTION BLOCKS FOR CODESYS

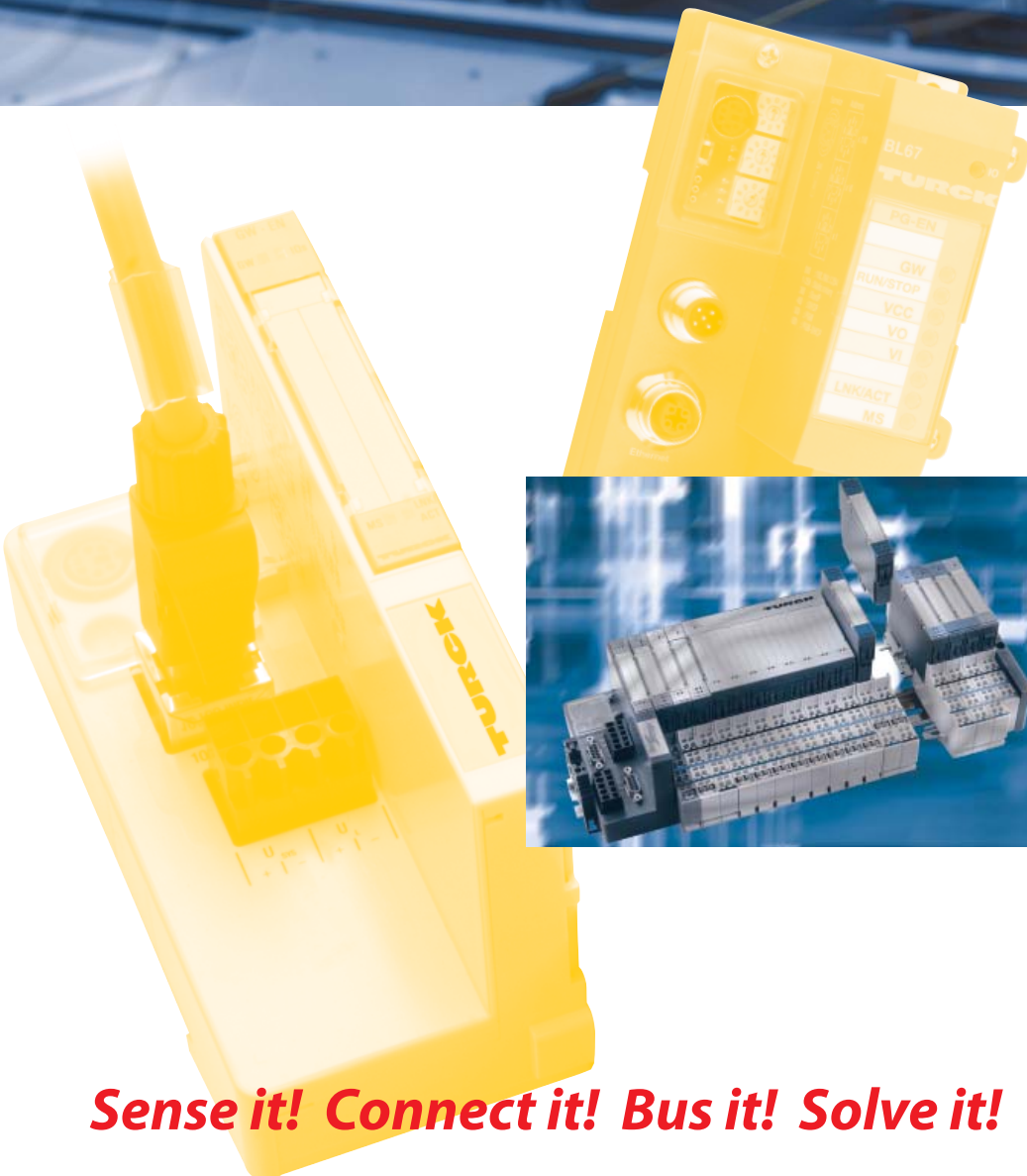
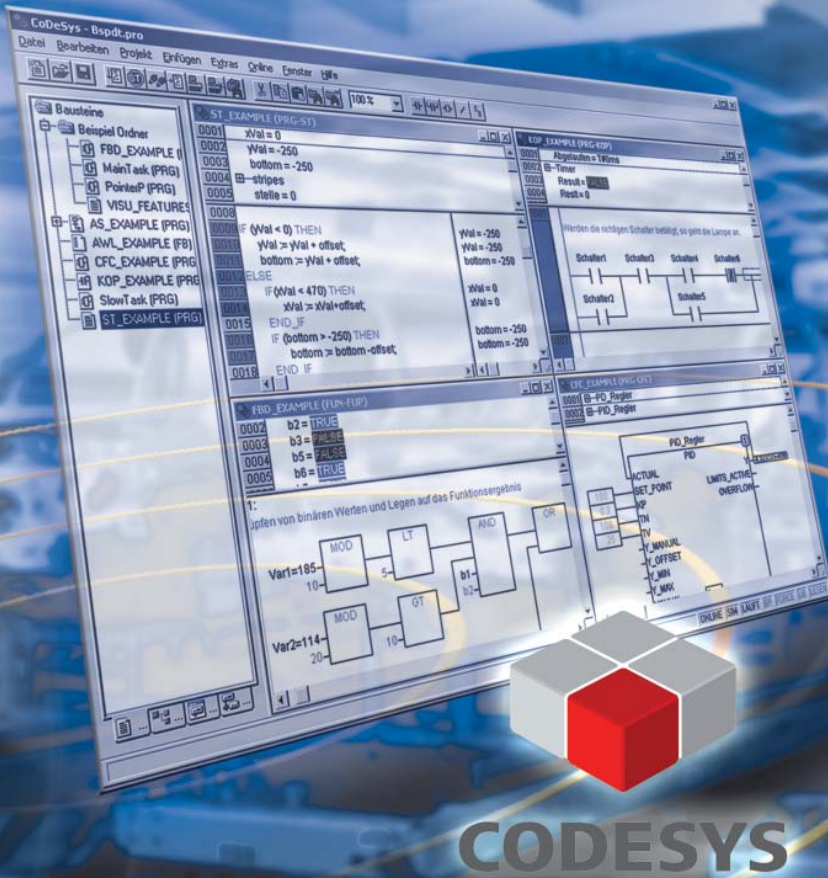

Sense it! Connect it! Bus it! Solve it!

All brand and product names are trademarks or registered trade marks of the owner concerned.

Edition 10/2012

© Hans Turck GmbH, Muelheim an der Ruhr

All rights reserved, including those of the translation.

No part of this manual may be reproduced in any form (printed, photocopy, microfilm or any other process) or processed, duplicated or distributed by means of electronic systems without written permission of Hans Turck GmbH & Co. KG, Muelheim an der Ruhr.

Subject to alterations without notice

Table of contents

1	CoDeSys - function blocks for programmable gateways	
1.1	Installation	1-2
1.2	General	1-3
1.3	BL20-function blocks	1-4
1.3.1	BL20-1CNT-24VDC-module	1-4
1.4	BL20/BL67-function blocks	1-8
1.4.1	BLxx-1RS232- and BLxx-1RS482/422-modules.....	1-8
1.4.2	BLxx-1SSI-Modul.....	1-11
2	Application example for a BLxx_1RSxxx_FB with Hyper Terminal	
2.1	General	2-2
2.1.1	Windows HyperTerminal	2-3
2.2	Setting-up the communication parameters	2-4
2.2.1	Setting-up the module parameters in CoDeSys	2-4
2.2.2	Setting-up the properties in HyperTerminal	2-5
2.3	CoDeSys - calling the FB and variable declaration	2-6
2.4	Transmission of data (module → HyperTerminal)	2-7
2.5	Reception of data (HyperTerminal → module)	2-8

1 CoDeSys - function blocks for programmable gateways

1.1	Installation	2
1.2	General	3
1.3	BL20-function blocks	4
1.3.1	BL20-1CNT-24VDC-module	4
	– Variable description	4
	– Example for the PLC configuration of the module BL20-1CNT	7
1.4	BL20/BL67-function blocks	8
1.4.1	BLxx-1RS232- and BLxx-1RS482/422-modules	8
	– Structure of the function block	8
	– Variable description	9
	– Example for the PLC configuration of the module BLxx-1RSxxx	10
1.4.2	BLxx-1SSI-Modul	11
	– Structure of the function block	11
	– Variable description	11
	– Example for the PLC configuration of the module BLxx-1SSI	13

1.1 Installation

In order to use the function block described in the next pages, the file "BLxx_PG_FB.lib" has to be copied into the following Windows folder (choose the drive letter according to the installation path of the CoDeSys software):

C:\Programs\CommonFiles\CAA-Targets\Turck\BLxx

1.2 General

The gateways BL20-PG-xx and BL67-PG-xx support technology modules at the local module bus, which provide command and control bits for the data exchange via the process data.

In order to use these module functions, so called "handshake" mechanisms have to be programmed in the user program.

In the following, functions which control this handling are described. The functions are part of the BLxx_PG_FB.lib. This library is divided into two sub-directories:

- 1** BL20_PG_FB
with function block BL20_1CNT_FB for the module BL20-1CNT
- 2** BLxx_PG_FB
with function block BLxx_1RSxx_FB for the modules BLxx-1RS232 as well as BLxx-1RS422/485 and BLxx_1SSI_FB for the module BLxx-1SSI

Remark:

A prefix is added to the variable names. This prefix is chosen according to recommendations in the IEC 61131 and of 3S-Smart Software Solutions GmbH.

By means of this prefix the user can identify the variables' data types:

Example:

xVarName = data type BOOLEAN

bVarName = data type BYTE etc.

1.3 BL20-function blocks

The function blocks in this sub-directory are only valid for BL20 modules.

1.3.1 BL20-1CNT-24VDC-module

The function block BL20_1CNT_FB is used for handling the data of the module BL20-1CNT-24VDC in counter mode or measurement mode.

The function block works with the starting addresses of the counter module's process in- and output data. On the one hand, it shows the actual counter or measurement value and on the other hand, the module's functions described in the manual "BL20 I/O modules" (D300717) can be controlled.

Figure 1-1:
BL20_1CNT_FB

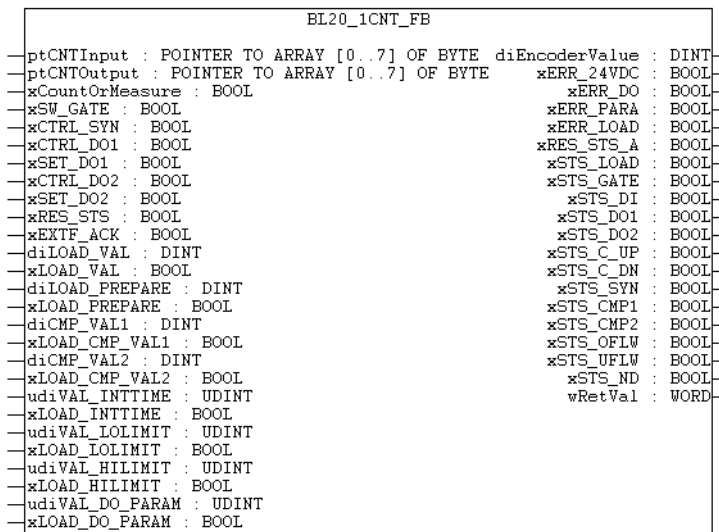

Variable description

For internal purpose, the process input and process output data are converted into data type BYTE. Therefore the variables "ptCNTInput" and "ptCNTOutput" are defined as data type POINTER.

Table 1-1:
Variable
description
BL20_1CNT_FB

Variable	Type	Meaning
ptCNTInput	POINTER TO ARRAY [0...7] OF BYTE	POINTER to the counter module's process input words e.g. ADR(%IW4) or ADR(CNT_IN) → Example for the PLC configuration of the module BL20-1CNT (page 1-7).
ptCNTOutput	POINTER TO ARRAY [0...7] OF BYTE	POINTER to the counter module's process output words e.g. ADR(%QW4) or ADR(CNT_OUT). → Example for the PLC configuration of the module BL20-1CNT (page 1-7).
xCountOrMeasure	BOOL	The module's operation mode as chosen in the PLC configuration: 0 = counter mode 1 = measurement mode

Table 1-1:
Variable
description
BL20_1CNT_FB

Variable	Type	Meaning
xSW_GATE	BOOL	Software release for counting or measurement
xCTRL_SYN	BOOL	Release synchronization
xCTRL_DO1	BOOL	Release output DO1
xSET_DO1	BOOL	Control bit output DO1
xCTRL_DO2	BOOL	Release output DO2
xSET_DO2	BOOL	Control bit output DO2
xRES_STS	BOOL	Reset status bits: 0 → 1 start reset
xEXTF_ACK	BOOL	Acknowledgment of diagnostic error
diLOAD_VAL	DINT	for counter mode: Value for "load value directly"
xLOAD_VAL	BOOL	for counter mode: load "load value directly"
diLOAD_PREPARE	DINT	for counter mode: value for "load value in preparation"
xLOAD_PREPARE	BOOL	for counter mode: load "load value in preparation"
diCMP_VAL1	DINT	for counter mode: value for "reference value 1"
xLOAD_CMP_VAL1	BOOL	for counter mode: load "reference value 1"
diCMP_VAL2	DINT	for counter mode: value for "reference value 2"
xLOAD_CMP_VAL2	BOOL	for counter mode: load "reference value 2"
udiVAL_INTTIME	UDINT	for measurement mode: value for "integration time"
xLOAD_INTTIME	BOOL	for measurement mode: load "integration time"
udiVAL_LOLIMIT	UDINT	for measurement mode: value for "lower limit"
xLOAD_LOLIMIT	BOOL	for measurement mode: load "lower limit"
udiVAL_HILIMIT	UDINT	for measurement mode: value for "upper limit"
xLOAD_HILIMIT	BOOL	for measurement mode: load "upper limit"
udiVAL_DO_PARAM	UDINT	Function and behavior output DO1 and DO2
xLOAD_DO_PARAM	BOOL	Change function and behavior output DO1 and DO2
xSTS_LOAD	BOOL	Load function and behavior output DO1 and DO2
diEncoderValue	DINT	Count value
xERR_24VDC	BOOL	Error bit short-circuit sensor or error at power supply

Table 1-1:
Variable
description
BL20_1CNT_FB

Variable	Type	Meaning
xERR_DO	BOOL	Error bit short-circuit at output DO1
xERR_PARA	BOOL	Error bit parameterization
xERR_LOAD	BOOL	Error bit load procedure
xRES_STS_A	BOOL	Reset status bits active
xSTS_LOAD	BOOL	Load procedure running
xSTS_GATE	BOOL	Status release counter module
xSTS_DI	BOOL	Status hardware input
xSTS_DO1	BOOL	Status hardware output DO1
xSTS_DO2	BOOL	Status software output DO2
xSTS_C_UP	BOOL	Status count direction up
xSTS_C_DN	BOOL	Status count direction down
xSTS_SYN	BOOL	Status synchronization
xSTS_CMP1	BOOL	Status comparator 1
xSTS_CMP2	BOOL	Status comparator 2 2
xSTS_OFLW	BOOL	Status upper count limit
xSTS_UFLW	BOOL	Status lower count limit
xSTS_ND	BOOL	Status zero crossing
wRetVal	WORD	Returned value: Value > 8000h → Error
	- 0x8101:	Size of input data ≠ 8 Bytes → abort FB
	- 0x8103	Size of output data ≠ 8 Bytes → abort FB

Example for the PLC configuration of the module BL20-1CNT

In this example, the assignment of the process input data to the variable "ptCNTInput" can be done in different ways:

- 1 as ADR(CNT_IN), if a symbolic name has been assigned to the input address,
- 2 or directly as ADR(%IW4)

This is also valid for the process output data in variable "ptCNTOutput":

- 1 as ADR(CNT_OUT), if a symbolic name has been assigned to the output address,
- 2 or directly as ADR%QW4)

Figure 1-2:
Example

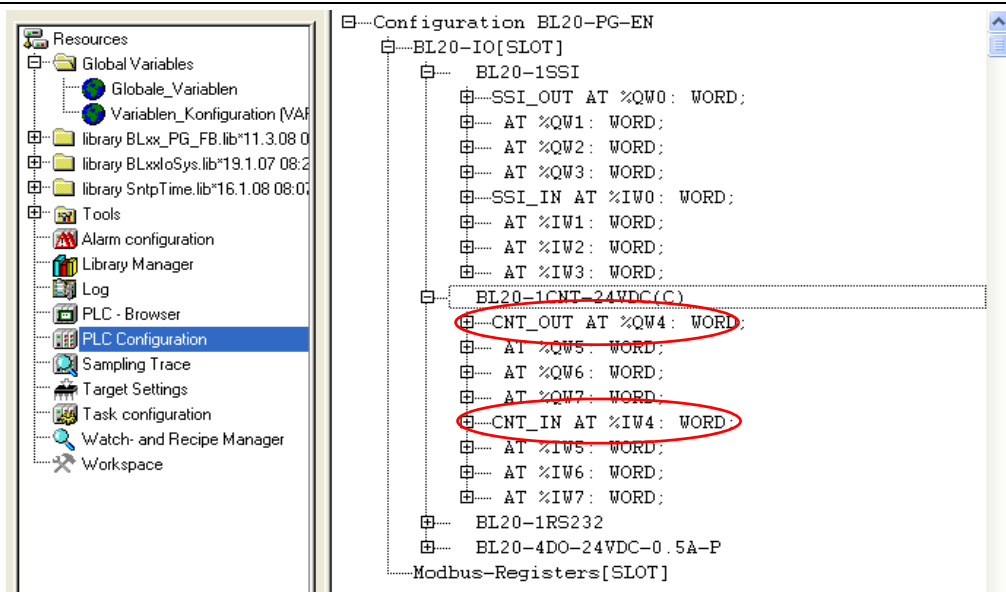

1.4 BL20/BL67-function blocks

The function blocks described in the following section can be used for both, BL20 as well as BL67 modules.

1.4.1 BLxx-1RS232- and BLxx-1RS482/422-modules

The function block BLxx_1RSxxx_FB can be used for the data handling of the interface modules (BL20-1RS232, BL20-1RS485/422, BL67-1RS232 und BL67-1RS485/422). It supports the simultaneous transmitting and receiving of data, which means, a full duplex mode, for example with the module BLxx-1RS232, is possible. As only the in- and output data are evaluated, this function block can be chosen regardless of the type of interface which is used.

The function block recalls the process input data (ptRxData) and stores them to the data buffer (ptRxBuffer). The size and the location of the data buffer are determined by the user.

Additionally, the user can define the number of bytes within a telegram (uiMaxRxBuffer).

The same applies for the transmit data.

Structure of the function block

Figure 1-3:
Structure of the
function block
BLxx_1RSxxx_FB

BLXX_1RSXXX_FB	
ptRxData : POINTER TO ARRAY [0..7] OF BYTE	xBusyRx : BOOL
ptTxData : POINTER TO ARRAY [0..7] OF BYTE	uiReceivedBytes : UINT
xEnableRx : BOOL	xBusyTx : BOOL
xEnableTx : BOOL	uiSentBytes : UINT
xQuit : BOOL	xSendBufNotEmpty : BOOL
xClr_Buf_Rx : BOOL	wRetVal : WORD
xClr_Buf_Tx : BOOL	
xDisableTxBuffer : BOOL	
ptRxBuffer : POINTER TO BYTE	
uiMaxRxBytes : UINT	
ptTxBuffer : POINTER TO BYTE	
uiMaxTxBytes : UINT	

Variable description

For internal purpose, the process input and process output data are converted into data type BYTE. Therefore the variables "ptRxData" and "ptTxData" are defined as data type POINTER.

Table 1-2:
Variable
description
BLxx_1RSxxx_
FB

Variable	Type	Meaning
ptRxData	POINTER TO ARRAY [0...7] OF BYTE	Pointer to the module's process input data e.g. ADR(%IW8) or ADR(RS232_RX) → Example for the PLC configuration of the module BLxx-1RSxxx (page 1-10) .
ptTxData	POINTER TO ARRAY [0...7] OF BYTE	Pointer to the module's process output data e.g. ADR(%IQ8) or ADR(RS232_TX) → Example for the PLC configuration of the module BLxx-1RSxxx (page 1-10) .
xEnableRx	BOOL	Release for data reception
xEnableTx	BOOL	Release for data transmission
xQuit	BOOL	Acknowledgment of errors
xClr_Buf_Rx	BOOL	Flushing of receive buffer: 0 → 1 and Quit = 1
xClr_Buf_Tx	BOOL	Flushing of transmit buffer: 0 → 1 and Quit = 1
xDisableTxBuffer	BOOL	Disabling transmit buffer: 0 = release; 1 = disable
ptRxBuffer	POINTER TO BYTE	Address of the buffer for receive data within the PLC. Array of n elements of data type BYTE.
uiMaxRxBytes	UINT	Maximum number of the data byte to be received within one telegram. Can be changed before a new job according to the expected telegram length. Note: Has to be > 0, if not, data are not received.
ptTxBuffer	POINTER TO BYTE	Address of the buffer for the transmit data within the PLC. Array of n elements of data type BYTE.
uiMaxTxBytes	UINT	Maximum number of the data byte to be transmitted within one telegram. Can be changed before a new job according to the expected telegram length. Note: Has to be > 0, if not, data are not transmitted.
xBusyRx	BOOL	Displays an active data reception.
uiReceivedBytes	UINT	Counter for the received data bytes
xBusyTx	BOOL	Displays an active data transmission
uiSentBytes	UINT	Counter for the transmitted data bytes

Table 1-2:
Variable
description
BLxx_1RSxxx_
FB

Variable	Type	Meaning
xSentByteNotEmpty	BOOL	-
wRetVal	WORD	Return Value: value > 8000h → error
- error of size variables	0x8101	"Size of receive buffer" > the "max. number of bytes to be received" → abort FB
	0x8103	Size of array of input data ≠ 8 Bytes → abort FB
	0x8201	"Size of transmit buffer" > the "max. number of bytes to be sent" → abort FB
	0x8203	Size of array of output data ≠ 8 Bytes → abort FB
- module errors	0x8000	Module not ready for communication
	0x8008	Parameter error at module
	0x8010	Hardware error at module
	0x8020	Error in data flow control
	0x8040	Frame error
	0x8080	(Receive-)buffer overflow

Example for the PLC configuration of the module BLxx-1RSxxx

In this example, the assignment of the process input data to the variable "ptRxData" can be done in different ways:

- 1 as ADR(RS232_RX), if a symbolic name has been assigned to the input address,
- 2 or directly as ADR(%IW8)

This is also valid for the process output data in variable "ptTxData":

- 1 as ADR(RS232_TX), if a symbolic name has been assigned to the output address, or directly as ADR(%QW8).

Figure 1-4:
Example

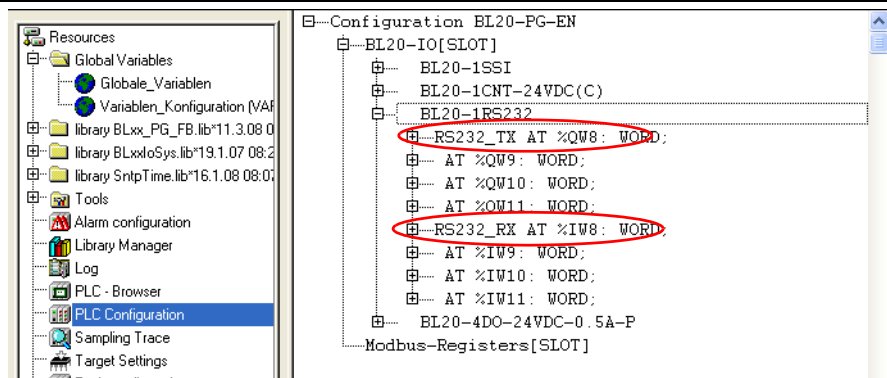

1.4.2 BLxx-1SSI-Modul

The function block BLxx_1SSI_FB is used for the data handling of a module BL20-1SSI and BL67-1SSI.

Structure of the function block

Figure 1-5:
Structure of the
function block
BLxx_1SSI_FB

BLXX_1SSI_FB	
ptSSIInput : POINTER TO ARRAY [0..7] OF BYTE	dwRegRdData : DWORD
ptSSIOutput : POINTER TO ARRAY [0..7] OF BYTE	bRegRdAdrStat : BYTE
xStop : BOOL	xRegRdAbort : BOOL
xEnCMP1 : BOOL	xRegWrAckn : BOOL
xClrCMP1 : BOOL	xRegWrAccept : BOOL
xEnCMP2 : BOOL	xStsCMP1 : BOOL
xClrCMP2 : BOOL	xFlagCMP1 : BOOL
diREG_CMP1 : DINT	xRelCMP1 : BOOL
xLOAD_REG_CMP1 : BOOL	xStsCMP2 : BOOL
diREG_CMP2 : DINT	xFlagCMP2 : BOOL
xLOAD_REG_CMP2 : BOOL	xRelCMP2 : BOOL
diREG_LOWER_LIMIT : DINT	xStsDn : BOOL
xLOAD_REG_LOWER_LIMIT : BOOL	xStsUp : BOOL
diREG_UPPER_LIMIT : DINT	xStsOflw : BOOL
xLOAD_REG_UPPER_LIMIT : BOOL	xStsUflw : BOOL
xRegWR : BOOL	xStsStop : BOOL
bRegRdAdr : BYTE	xSSIDdiag : BOOL
bRegWrAdr : BYTE	xSSISts0 : BOOL
diRegWrData : DINT	xSSISts1 : BOOL
	xSSISts2 : BOOL
	xSSISts3 : BOOL
	xErrSSI : BOOL
	xErrPara : BOOL
	wRetVal : WORD

Variable description

For internal purpose, the process input and process output data are converted into data type BYTE. Therefore the variables "ptSSIInput" and "ptSSIOutput" are defined as data type POINTER.

Table 1-3:
Variable
description
BLxx_1SSI_FB

Variable	Type	Meaning
ptSSIInput	POINTER TO ARRAY [0...7] OF BYTE	Pointer to the module's process input data e.g. ADR(%IW0) or ADR(SSI_IN) → Example for the PLC configuration of the module BLxx-1SSI (page 1-13) .
ptSSIOutput	POINTER TO ARRAY [0...7] OF BYTE	Pointer to the module's process output data e.g. ADR(%QW0) or ADR(SSI_OUT) → Example for the PLC configuration of the module BLxx-1SSI (page 1-13) .
xStop	BOOL	Communication control: 0 = cyclic reading; 1 = communication stopped
xEnCMP1	BOOL	Release comparison 1
xClrCMP1	BOOL	Delete comparison bit 1
xEnCMP2	BOOL	Release comparison 2
xClrCMP2	BOOL	Delete comparison bit 2
diREG_CMP1	DINT	Comparison value 1
xLOAD_REG_CMP1	BOOL	Load comparison value 1

Table 1-3:
Variable
description
BLxx_1SSI_FB

Variable	Type	Meaning
diREG_CMP2	DINT	Comparison value 2
xLOAD_REG_CMP2	BOOL	Load comparison value 2
diREG_LOWER_LIMIT	DINT	Value for lower limit
xLOAD_REG_LOWER_LIMIT	BOOL	Load value for lower limit
diREG_UPPER_LIMIT	DINT	Value for upper limit
xLOAD_REG_UPPER_LIMIT	BOOL	Load value for upper limit
xRegWR	BOOL	Release for writing a register: 0 → 1 active
bRegRdAdr	BYTE	Address for reading a register
bRegWrAdr	BYTE	Address for writing a register
diRegWrData	DINT	Data of the register to be written
dwRegRdData	DWORD	Data of the register to be read
bRegRdAdrStat	BYTE	Acknowledge of the register which was read
xRegRdAbort	BOOL	Abort of reading registers
xRegWrAkn	BOOL	Acknowledge WRITE register running
xRegWrAccept	BOOL	Acknowledge WRITE register accepted
xStsCMP1	BOOL	Status bit COMP1: 1 = RegSSIPos = RegCMP1; 0 = RegSSIPos ≠ RegCMP1
xFlagCMP1	BOOL	Status bit COMP1 (latch): 1 = RegSSIPos = RegCMP1; 0 = RegSSIPos ≠ RegCMP1
xReICMP1	BOOL	Status bit COMP1: 1 = RegSSIPos ≥ RegCMP1; 0 = RegSSIPos < RegCMP1
xStsCMP2	BOOL	Status bit COMP2 1 = RegSSIPos = RegCMP2; 0 = RegSSIPos ≠ RegCMP2
xFlagCMP2	BOOL	Status bit COMP2 (latch): 1 = RegSSIPos = RegCMP2; 0 = RegSSIPos ≠ RegCMP2
xReICMP2	BOOL	Status bit COMP2 1 = RegSSIPos ≥ RegCMP2; 0 = RegSSIPos < RegCMP2
xSstDN	BOOL	Status count direction down

Table 1-3:
Variable
description
BLxx_1SSI_FB

Variable	Type	Meaning
xStsOflw	BOOL	Status overflow
xStsUflw	BOOL	Status underflow
xStsStop	BOOL	Status communication
xSSIDdiag	BOOL	Display: diagnostic message present
xSSISts0	BOOL	Diagnostic bit 0
xSSISts1	BOOL	Diagnostic bit 1
xSSISts2	BOOL	Diagnostic bit 2
xSSISts3	BOOL	Diagnostic bit 3
xERR_SSI	BOOL	Status encoder signal: 1 = error (wire break) 0 = O.K.
xERR_PARA	BOOL	Status parameterization: 1 = error 0 = O.K.
wRetVal	WORD	Return Value: value > 8000h → error
	- 0x8101:	Size of array of input data ≠ 8 Bytes → abort FB
	- 0x8103	Size of array of output data ≠ 8 Bytes → abort FB

Example for the PLC configuration of the module BLxx-1SSI

In this example, the assignment of the process input data to the variable "ptSSIInput" can be done in different ways:

- 1 as ADR(SSI_IN), if a symbolic name has been assigned to the input address,
- 2 or directly as ADR(%IW0)

This is also valid for the process output data in variable "ptSSI_Output":

- 1 as ADR(SSI_OUT), if a symbolic name has been assigned to the output address, or directly as ADR%QW0).

Figure 1-6:
Example

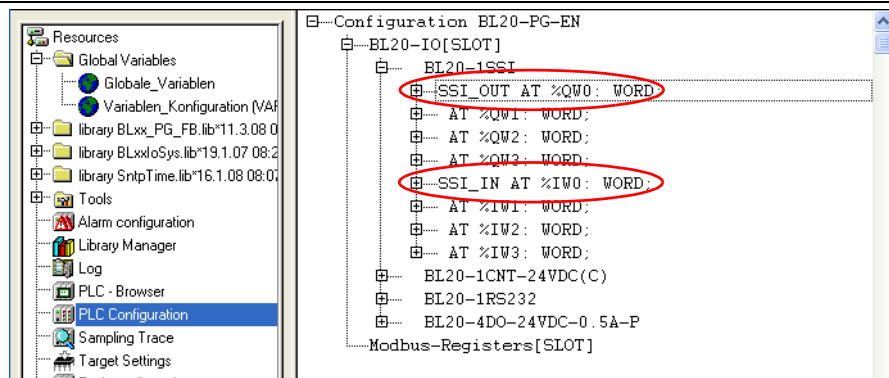

2 Application example for a BLxx_1RSxxx_FB with Hyper Terminal

2.1	General	2
2.1.1	Windows HyperTerminal.....	3
2.2	Setting-up the communication parameters	4
2.2.1	Setting-up the module parameters in CoDeSys	4
2.2.2	Setting-up the properties in HyperTerminal.....	5
2.3	CoDeSys - calling the FB and variable declaration	6
2.4	Transmission of data (module → HyperTerminal)	7
2.5	Reception of data (HyperTerminal → module)	8

2.1 General

By means of the following example, a RS232-communication between a BL20-station, consisting of a programmable gateway and amongst others one RS232-module, and a Windows HyperTerminal is described.

The connection between RS232-module and PC is realized via the PC's COM-interface:

Figure 2-1:
Connection
between
BL20-1RS232
and D-sub male
connector

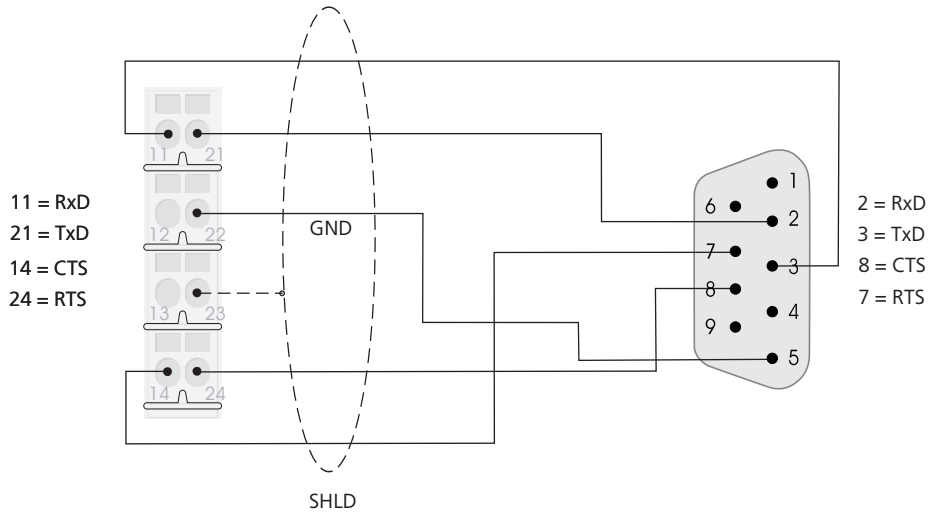

Assignment of the signal types at a 9-pole Submin-D male connector

Table 1:
Assignment of
the signal types
RS232

Pin- No.	Signal designation
1	DCD Data Carrier Detect
2	RxD Receive Data
3	TxD Transmit Data
4	DTR Data Terminal Ready
5	GND Ground
6	DSR Data Set Ready
7	RTS Request To Send
8	CTS Clear To Send
9	RI Ring Indicator



Note

The table rows highlighted in grey indicate signals that are also available at the terminals of the base module.

2.1.1 Windows HyperTerminal

Windows-HyperTerminal is opened via "Start → (All) Programs → Accessories → Communication → HyperTerminal".

**Note**

Enter your "Area Code". Entering the phone number is not necessary for a serial connection at the PC.

Enter a user defined connection name in the dialog box „Connection Description“ and define the COM port, via which the connection between PC and module has to be established.

Figure 2-2:
Windows
HyperTerminal

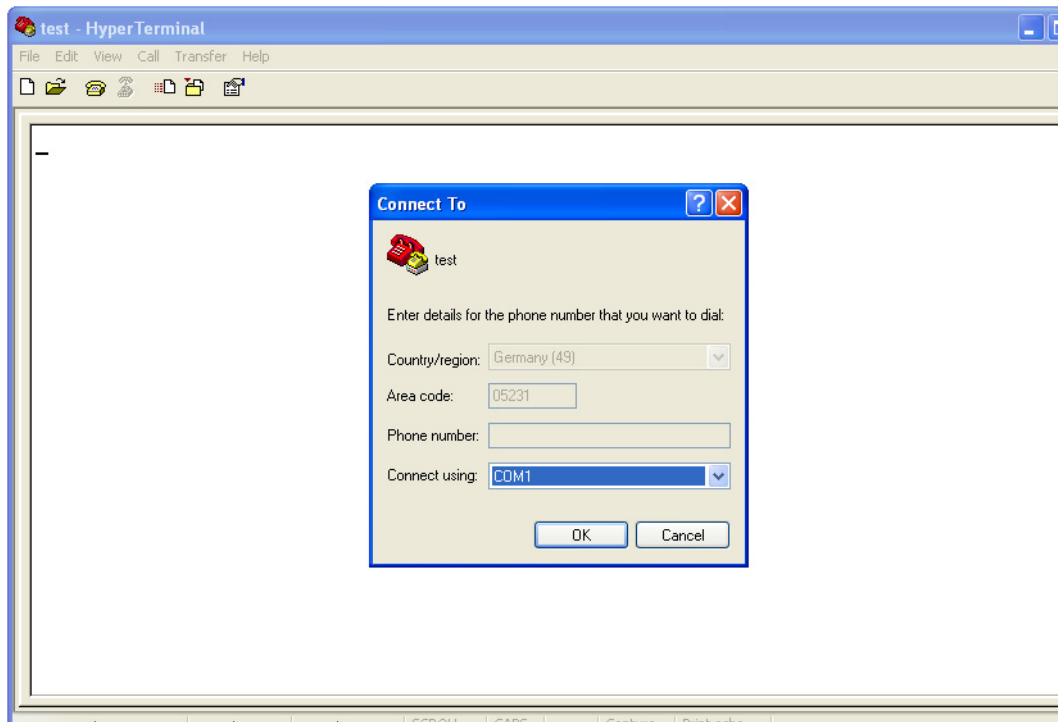

2.2 Setting-up the communication parameters



Note

In order to guarantee an error-free RS232-communication, the communication parameters of both RS232-nodes (RS232-module and HyperTerminal) have to be identical.

2.2.1 Setting-up the module parameters in CoDeSys

The RS232-module's parameter definition is done in the PLC configuration.

Mark the entry BLxx-IO [Slot] and select the module BL20-1RS232 under „Selected Modules“ in the "Input/Output"-tab.

After this, open the parameterization dialog box „Module Properties“ via the „Properties“ button.

Figure 2-3: IO module, properties

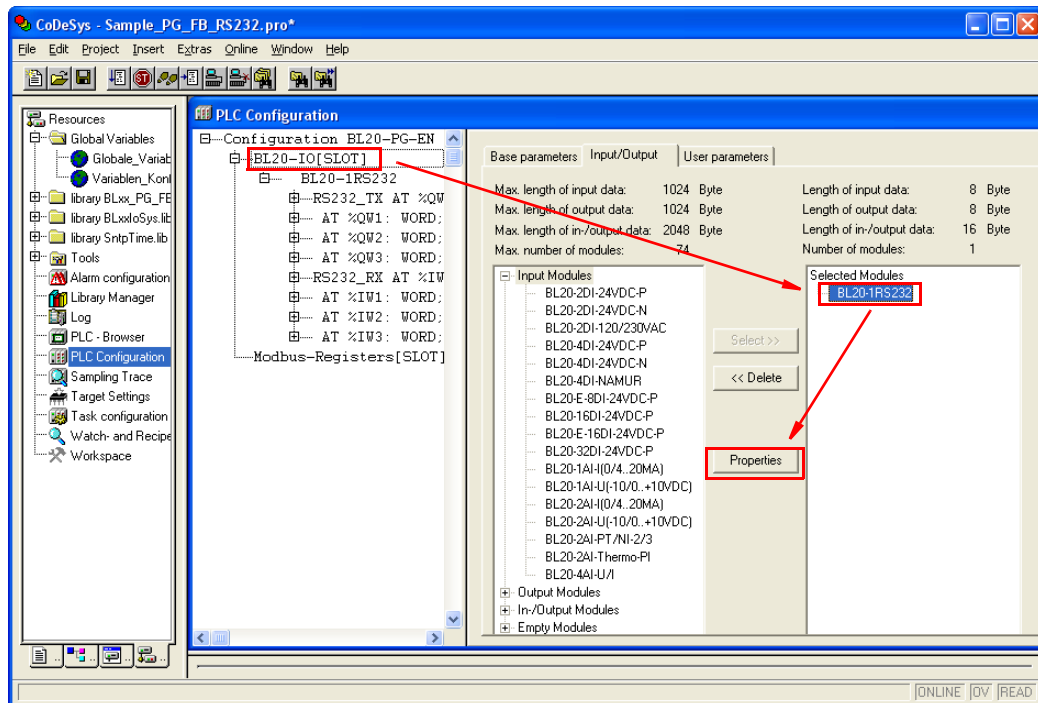
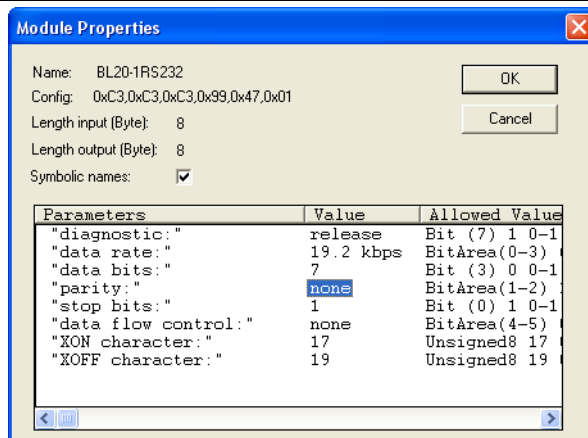

Figure 2-4: Parameterization in "Module Properties"



2.2.2 Setting-up the properties in HyperTerminal

Configure HyperTerminal according to the application ("File → Properties"). The configuration is only possible if the connection is inactive. If necessary, an active communication has to be disconnected via "Call → Disconnect" first.



Note

Please note that the configuration for the RS232-module and for the HyperTerminal are identical. Otherwise an error-free communication can not be guaranteed.

Figure 2-5:
Windows
HyperTerminal,
configuration

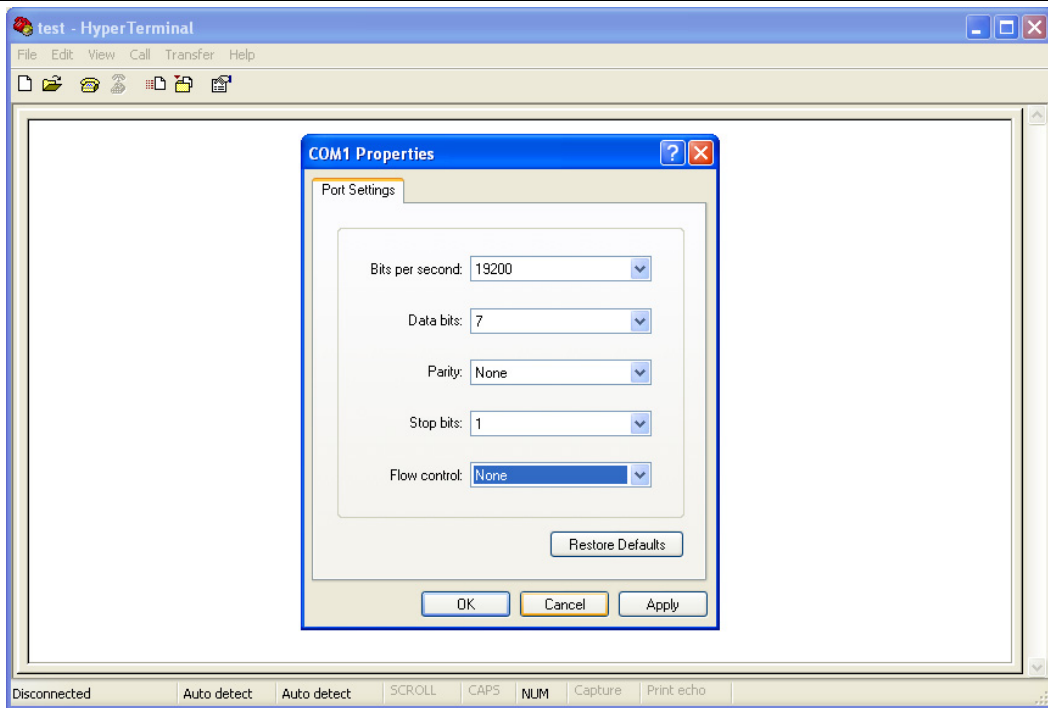

2.3 CoDeSys - calling the FB and variable declaration

Call the function block BLxx_RSxxx_FB for RS232-communication in the PLC_PRG.

If, in the PLC configuration, variables have been defined for the module's in- and output word (here in this example: "RS232_RX" and "RS232_TX"), then those variables have to be assigned to the pointers of the receive and transmit data buffers ("ptRxData" and "ptTxData", see also page 1-9).

Figure 2-6: Variable declaration and usage in the FB

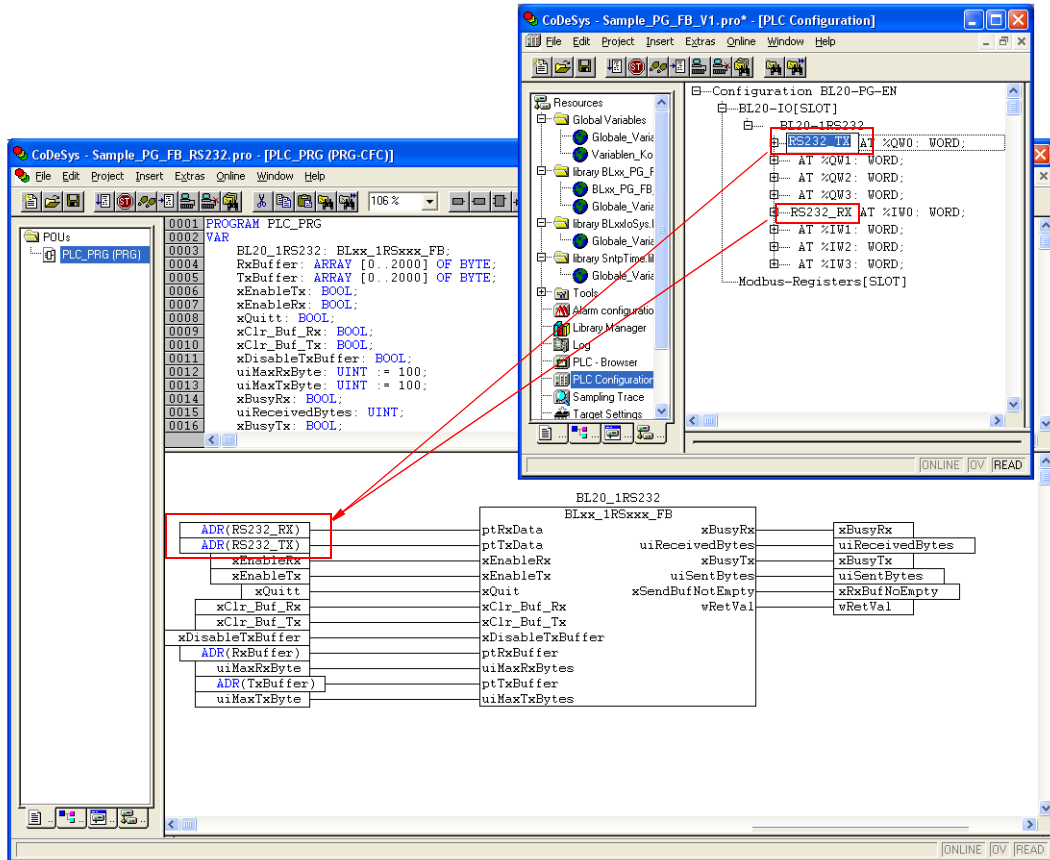

All other variables are already defined within the function block.



Note

It is also important to enter the maximum number of data to be transmitted and received in "uiMaxTxByte" or respectively "uiMaxRxByte". Without these entries no data is exchanged.

Figure 2-7: Max. number of data to be transmitted and received

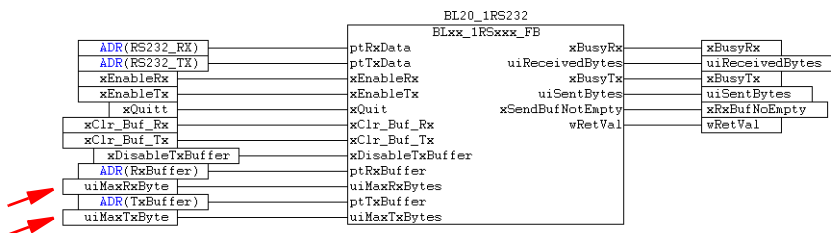

2.4 Transmission of data (module → HyperTerminal)

- 1 The data to be transmitted is written to the transmit buffer "TX_Buffer".
- 2 Then, the transmission has to be enabled in the FB/ module. Set the variable "xEnableTx" to TRUE.
- 3 HyperTerminal shows the received data in ASCII code.

Figure 2-8:
Transmission

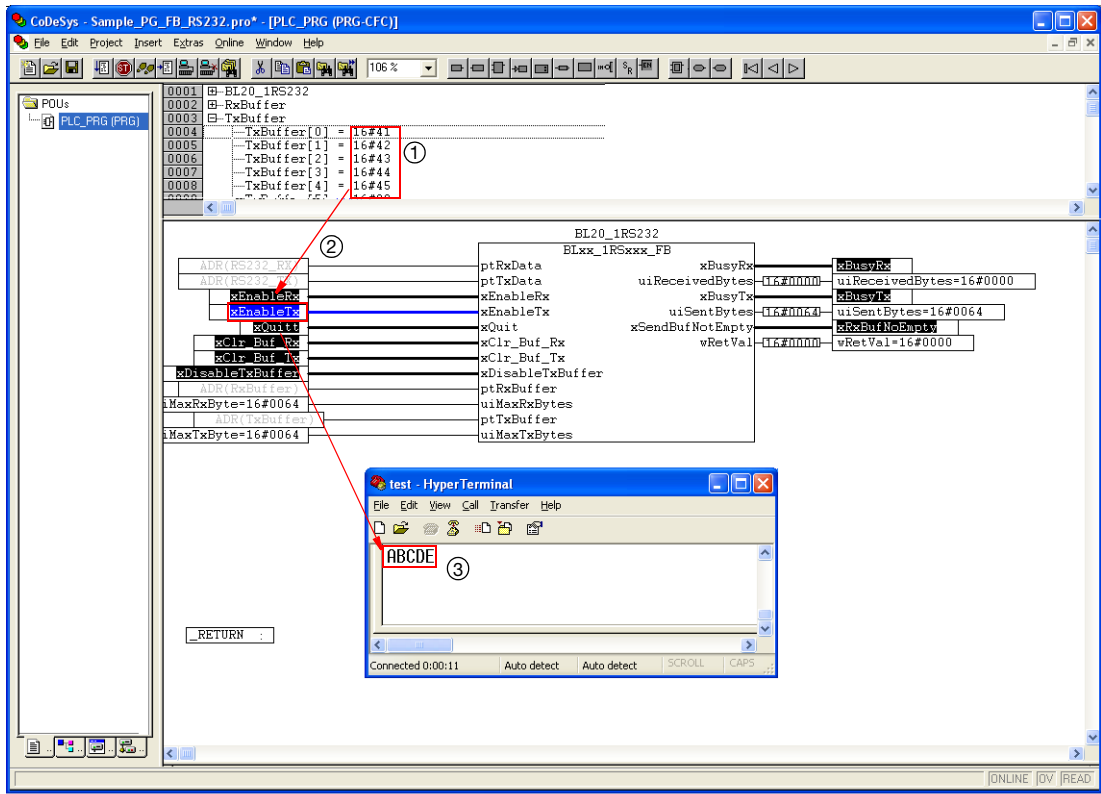

2.5 Reception of data (HyperTerminal → module)

- 1 Write the data to be sent into HyperTerminal.
- 2 Then, enable the data reception in the FB/ module. Set the variable "xEnableRx" to TRUE.
- 3 The received data will be shown in the receive buffer „RxBuffer“.

Figure 2-9:
Reception

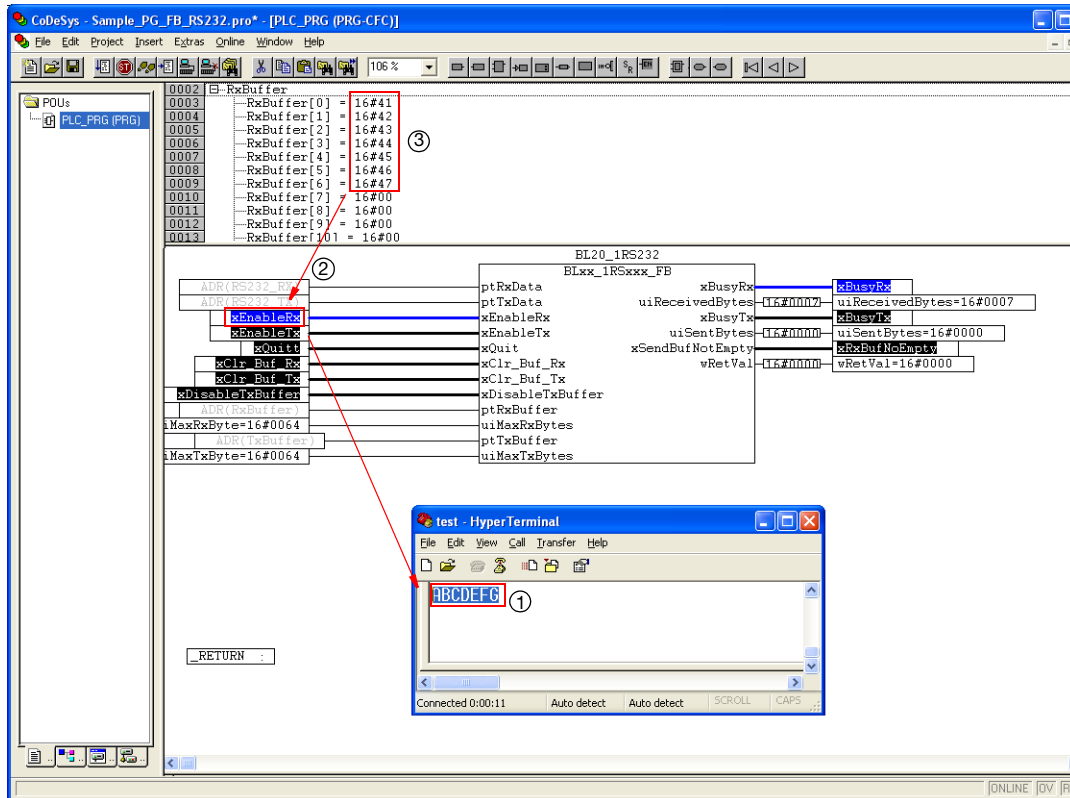

TURCK

Industrial
Automation



www.turck.com

Hans Turck GmbH & Co. KG
45472 Mülheim an der Ruhr
Germany
Witzlebenstraße 7
Tel. +49 (0) 208 4952-0
Fax +49 (0) 208 4952-264
E-Mail more@turck.com
Internet www.turck.com

D301146 1012