

Photoelectrics Through-beam System, Relay Output Type MPF.RSL

CARLO GAVAZZI



- Industrial doors and gates
- Range: 15 m
- Modulated infrared light
- Option with individually adjustable channel sensitivity
- Amplifier with "Snap-ON" photoelectric switches
- Supply voltage: 12-24 VAC/DC
- Output: SPST relay (low voltage)
- LED indications for light ON and supply ON
- Ø12 mm "Snap-ON", Ø18 or M14 photoelectric housing
- 1, 2 or 3 multiplexed channels
- With make or break test input
- CE, UL325 and UL508 approved



Product Description

The MPFRS.. is a family of inexpensive general purpose photoelectric sensors in 3 different types of housings with separate amplifier. They are designed to meet the requirements for industrial doors and gates. The "Snap-ON" photo switch can be mounted in material with a thickness from 0.6 mm and up to 2.25 mm. The sensor set is easy to use and no adjustments are necessary. The amplifier has

a test input designed to disable the emitters and therefore evaluate the sensor function. Multiplexed channels prevent cross-talk between each set of photosensors. The amplifier is available with the following voltage: 12-24 VAC/DC. The output is made as positive security e.g. power lost, short-circuit or broken sensor cable makes the relay go to off state.

Ordering Key

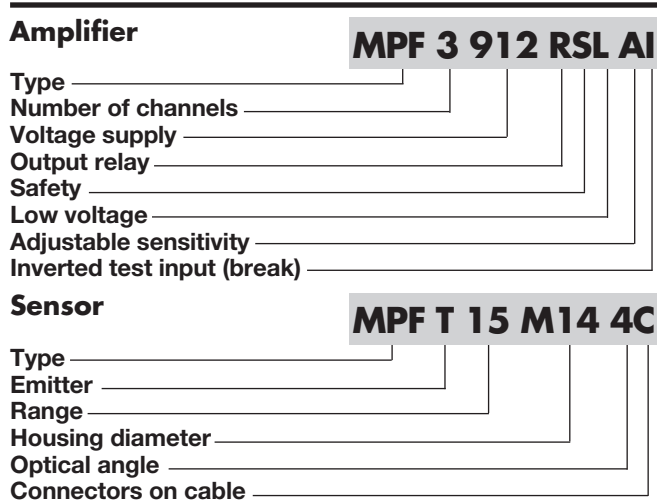

Type Selection, Amplifier

Housing W x H x D	Ordering no. Supply: 12-24 VAC/DC
70 x 57 x 86 mm	MPF1-912 RSL MPF2-912 RSL MPF3-912 RSL MPF1-912 RSLI *) MPF2-912 RSLI *) MPF3-912 RSLI *) MPF1-912 RSLA *) MPF2-912 RSLA *) MPF3-912 RSLA *) MPF1-912 RSLAI *) MPF2-912 RSLAI *) MPF3-912 RSLAI *)

*) Products available on request

Type Selection, Photoelectric Switch

Housing diameter	Rated operational distance (S _n)	Optical angle	Ordering no. Emitter	Ordering no. Receiver	Ordering no. Fitting
Ø12 mm	15 m	4°	MPFT 15-4	MPFR-4	AMPF-MB1
M14	15 m	4°	MPFT 15-M14-4	MPFR-M14-4	
D11	15 m	4°	MPF 15-D11-4	MPFR-D11-4	
D18	15 m	4°	MPFT 15-D18-4	MPFR-D18-4	
Ø12 mm	15 m	4°	MPFT 15-4C	MPFR-4C	
M14	15 m	4°	MPFT 15-M14-4C	MPFR-M14-4C	
D11	15 m	4°	MPF 15-D11-4C	MPFR-D11-4C	
D18	15 m	4°	MPFT 15-D18-4C	MPFR-D18-4C	
Fitting for Ø12					

Specifications, Amplifier

Rated operational volt. AC types (U _B) Terminals 1 & 3 MPF.- 912 RSL.	12-24 VAC/DC ± 15%, 50 to 60 Hz	Environment Overvoltage category Degree of protection Pollution degree	III (IEC 66064) IP 40 (IEC 60529/60947-5-2) 3 (IEC 60664/60664A, 60947-1)
Dielectric voltage	4 kVAC (rms)	Temperature Operating Storage	-20° to +60°C (-4° to +140°F) -30° to +80°C (-22° to +176°F)
Rated impulse withstand volt.	4 kV (1.2/50 μs)	Connection	Screw terminals (max. 2.5 mm ²)
Rated operational power AC supply DC supply	3 VA 2 W	Protection output	Reverse output, transients, short-circuit
Output Specifications Resistive load MPF.-912 RSL, RSLA, RSLI, RSLAI 600.000 switching 100.000 switching	0.5 A@50 VAC/30 VDC 0.5 A@125 VAC/1 A@30 VDC (UL)	Test input MPF.- 912 RSL. Testfunction activated Testfunction deactivated	Max. 28 V@15 mA AC/DC ≥ 3.5 V AC/DC ≤ 1.0 V AC/DC
Rated insulation volt. (U_i)	50 VAC (rms), 50 VDC	MPF.- 912 RSLI. Testfunction deactivated Testfunction activated	Max. 28 V@15 mA AC/DC ≥ 3.5 V AC/DC ≤ 1.0 V AC/DC
Operating frequency (f) Light/dark ratio 1:1 Contact output	10 Hz	Housing material	PC
Response time OFF-ON (t _{ON}) ON-OFF (t _{OFF})	≤ 50 ms ≤ 40 ms	Weight MPF.- 912 RSL.	126 g
Power ON delay (t_v)	≤ 300 ms	CE-marking UL-Approval	Yes UL325, CSA-C22.2 No.247 UL508 Yes (EN 12453)
Output function MPF1+2 MPF3	Relay 2 x SPST Relay 2 x SPST + 2 x SPST	TÜV-Approval	
Indication function Supply ON Beam ON (no object present)	LED, green LED, yellow		

Specifications, Photoelectric Switches

Rated operation dist. (S_n)	15 m - 8 m (UL 325)	MPFT15-XXX-4C MPFR15-XXX-4C <i>Connector is placed 15 cm from sensorhead</i> Cable	Red connector pair White connector pair PVC, grey, 10 m, Ø 2.9 mm ²
Light source	LED 880 nm	Degree of protection	IP 67 (IEC 60529/60947-5-2)
Light type	Infrared modulated	Mounting "Snap-ON" MPFT15-4/C MPFR-4/C Rubber profile MPFT15-D11-4/C MPFR-D11-4/C Rubber profile MPFT15-D18-4/C MPFR-D18-4/C Threaded barrel MPFT15-M14-4/C MPFR-M14-4/C	Ø12 mm or fitting D11 D18 M14
Ambient light	> 20.000 lux	CE-marking UL-Approval	Yes UL325, CSA-C22.2 No.247 UL508 Yes (EN 12453)
Housing material MPFT15-4/C MPFT15-D18-4/C MPFR-4/C MPFR-D11-4/C MPFR-D18-4/C Housing Backpart MPFT15-M14-4/C MPFR15-M14-4/C House Backpart	PA6 Glass filled PC ABS Stainless steel/PC PTE	TÜV-Approval	
Connection MPFT15-XXX-4 MPFR15-XXX-4 Cable	Max. 10 m cable length Max. 25 m cable length PVC, grey, 10 m, Ø 2.9 mm ²		

Operation Diagram



Wiring Diagrams

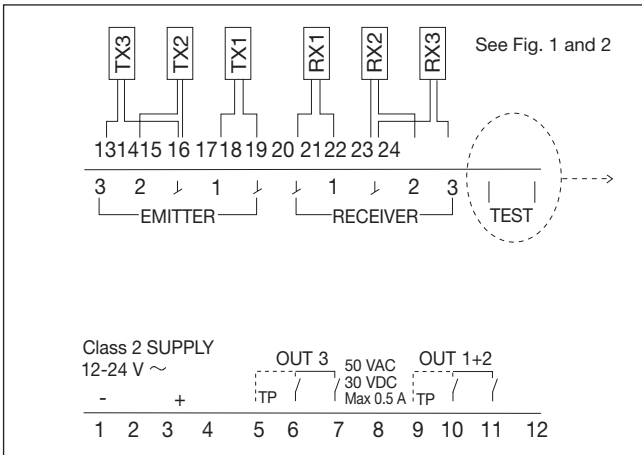
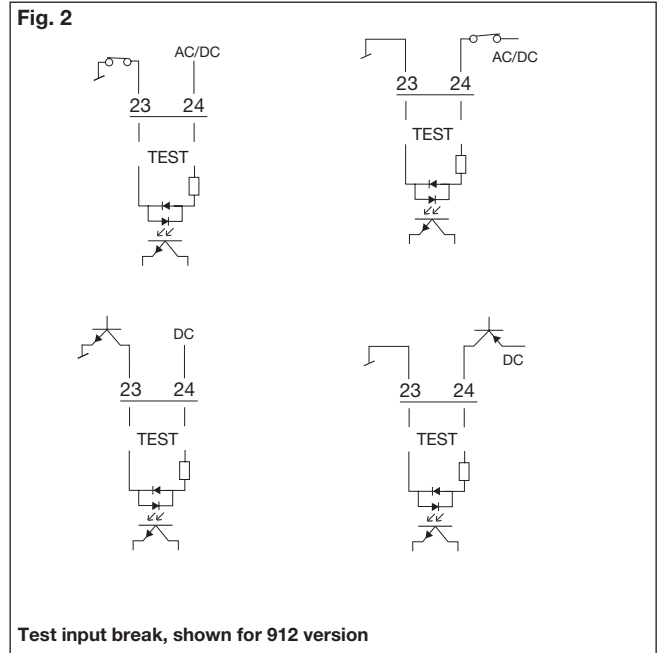
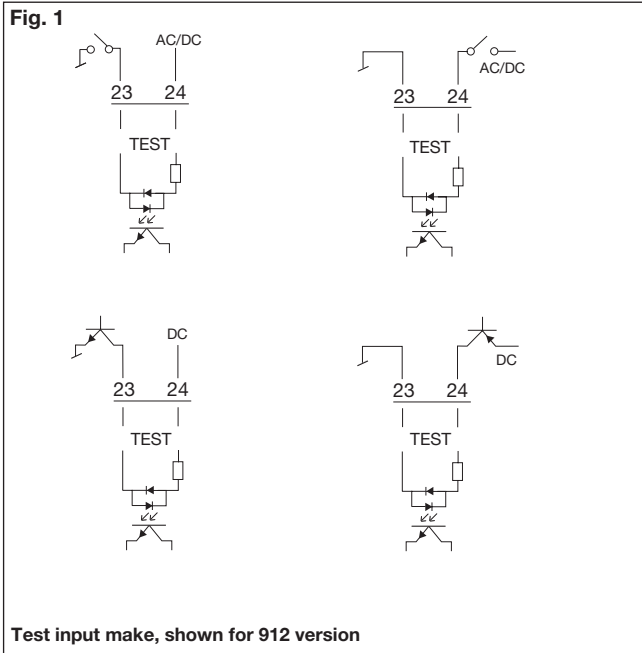

Delivery Contents

- Amplifier, MPF..
- Installation instruction
- **Packaging:** cardboard box

Detection Diagram

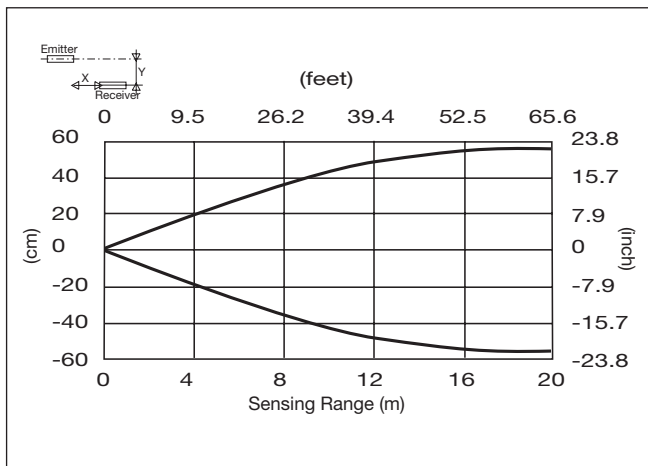

Excess Gain

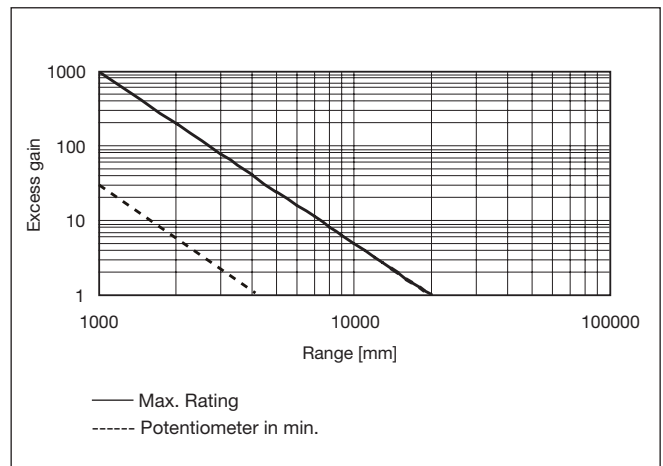

Dimensions

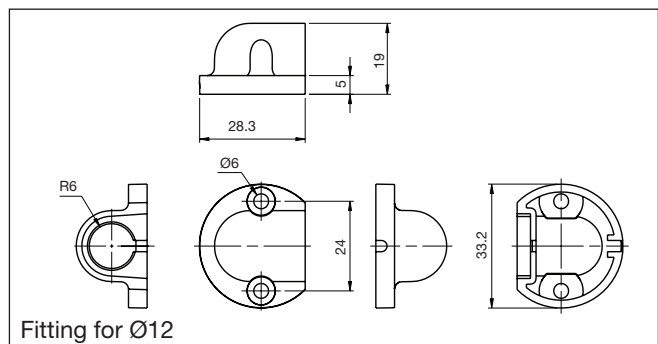
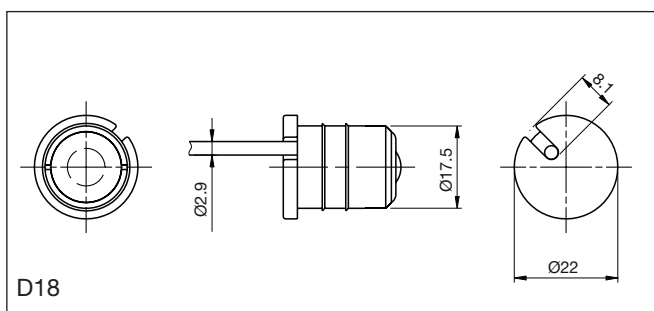
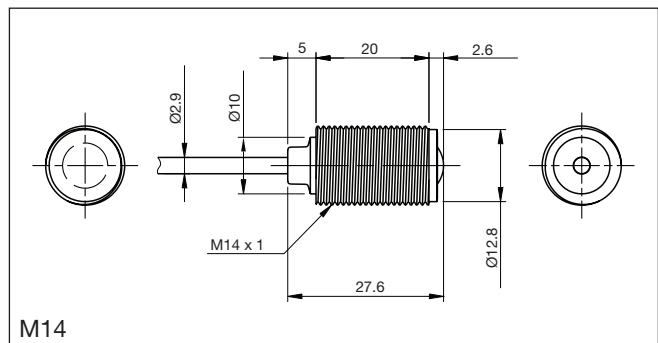
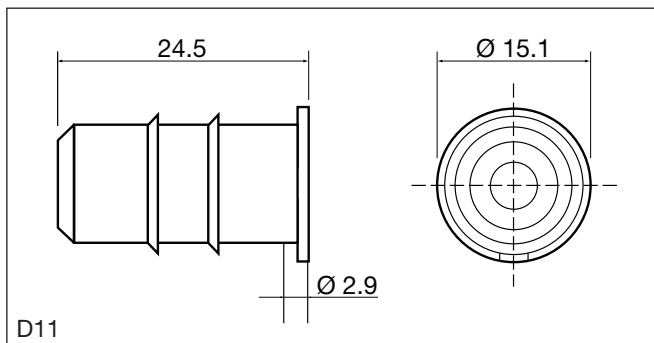
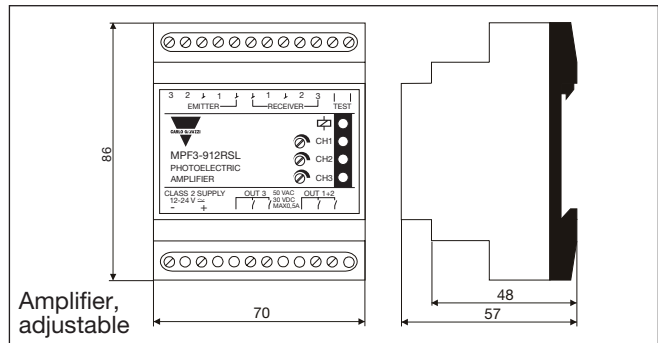
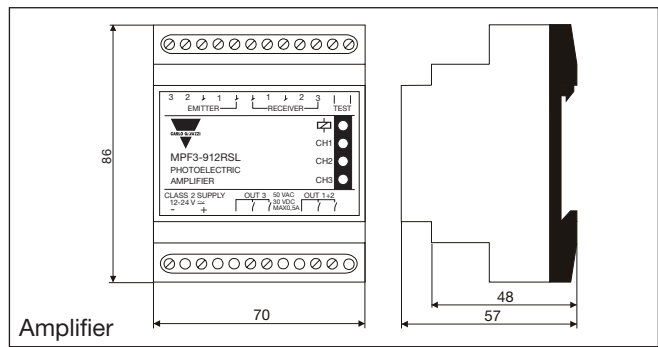
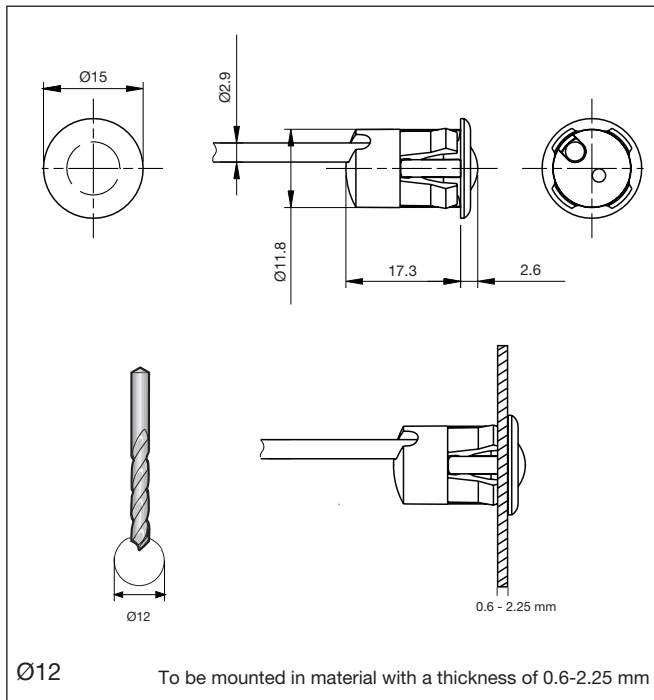

Installation Hints

