

Kinetix 5500 Servo Drives

Catalog Numbers 2198-H003-ERS, 2198-H008-ERS, 2198-H015-ERS, 2198-H025-ERS, 2198-H040-ERS, 2198-H070-ERS, 2198-H003-ERS2, 2198-H008-ERS2, 2198-H015-ERS2, 2198-H025-ERS2, 2198-H040-ERS2, 2198-H070-ERS2

Topic	Page
Summary of Changes	1
About the Kinetix 5500 Drives	1
Catalog Number Explanation	2
Before You Begin	2
Remove the Grounding Screws in Ungrounded Power Configurations	2
Install the Kinetix 5500 Servo Drive	3
Connector Data	6
Wiring Requirements	9
Attach the Motor Cable Shield Clamp	10
Circuit Breaker/Fuse Selection	12
Motor Overload Protection	14
Additional Resources	15

Summary of Changes

This publication contains new and updated information as indicated in the following table.

Topic	Page
Added 'impedance grounded' when ever ungrounded and corner-grounded power configurations are mentioned	2...3
Updated callouts in Grounding Screw figure and updated text in Grounding Screw table	3
Added 2198-Hxxx-ERS2 safety connector view and shared-bus wiring connectors to Features and Indicators figure	6
Updated Wiring Requirements table with text and values	9
Added Circuit Breaker/Fuse Selection tables	12...14
Updated text in Motor Overload Protection with new thermal retention feature in drive firmware 4.001 or later	14

About the Kinetix 5500 Drives

Kinetix® 5500 servo drives provide an Integrated Motion over the EtherNet/IP network solution for applications with output power and current requirements in the range of 0.2...14.6 kW and 1.4...32.5 A 0-pk, respectively.

See the Kinetix 5500 Servo Drives User Manual, publication [2198-UM001](#), for detailed information on wiring, applying power, troubleshooting, and integration with ControlLogix® 5570, ControlLogix 5580, and GuardLogix® 5570, or CompactLogix™ 5370 and Compact GuardLogix 5370 controllers.

Catalog Number Explanation

This publication applies to the following Kinetix 5500 servo drives. For connecting safe torque-off signals, hardwired drives use the safe torque-off (STO) connector and ship with the protective cover removed. Integrated safe torque-off drives do not use the STO connector and ship with the protective cover in place. See Connector Data on [page 6](#) to locate the cover.

Kinetix 5500 Drive Catalog Numbers

Drive Cat. No. (hardwired STO)	Drive Cat. No. (integrated STO)	Frame Size	Input Voltage	Continuous Output Power kW	Continuous Output Current A 0-pk
2198-H003-ERS	2198-H003-ERS2	1	195...264V rms, single-phase 195...264V rms, three-phase 324...528V rms, three-phase	0.2 kW 0.3 kW 0.6 kW	1.4
2198-H008-ERS	2198-H008-ERS2			0.5 kW 0.8 kW 1.6 kW	3.5
2198-H015-ERS	2198-H015-ERS2	2	195...264V rms, three-phase 324...528V rms, three-phase	1.0 kW 1.5 kW 3.2 kW	7.1
2198-H025-ERS	2198-H025-ERS2			2.4 kW 5.1 kW	11.3
2198-H040-ERS	2198-H040-ERS2	3	195...264V rms, three-phase 324...528V rms, three-phase	4.0 kW 8.3 kW	18.4
2198-H070-ERS	2198-H070-ERS2			7.0 kW 14.6 kW	32.5

Before You Begin

Remove all packing material, wedges, and braces from within and around the components. After unpacking, check the item nameplate catalog number against the purchase order.

The Kinetix 5500 servo drives ship with the following:

- Wiring plug connector set for mains input power (IPD), 24V control input power (CP), digital inputs (IOD), motor power (MP), motor brake (BC), and safe torque-off (STO)
- 2198-KITCON-DSL connector kit for motor feedback connections
- Wiring plug connector for shunt power (RC) connections that is installed on the drive
- These installation instructions, publication 2198-IN001

TIP Replacement connector sets are also available. See the Kinetix Servo Drives Specifications Technical Data, publication [GMC-TD003](#), for more information.

Remove the Grounding Screws in Ungrounded Power Configurations

Remove the grounding screws only when using ungrounded, corner-grounded, or impedance-grounded power configurations. Removing the screws involves gaining access, opening the side door, and removing the screws.

IMPORTANT If you have grounded wye power distribution, you do not need to remove the screws. Go to Install the Kinetix 5500 Servo Drive on [page 3](#). Removing the grounding screws can affect EMC performance.

Removing the grounding screws in multi-axis configurations is best done when the drive is removed from the panel and placed on its side on a solid surface that is equipped as a grounded static-safe workstation.



ATTENTION: Because the unit no longer maintains line-to-neutral voltage protection, the risk of equipment damage exists when you remove the grounding screws.



ATTENTION: To avoid personal injury, the grounding screws access door must be kept closed when power is applied. If power was present and then removed, wait at least 5 minutes for the DC-bus voltage to dissipate and verify that no DC-bus voltage exists before accessing the grounding screws.

Remove the Grounding Screws

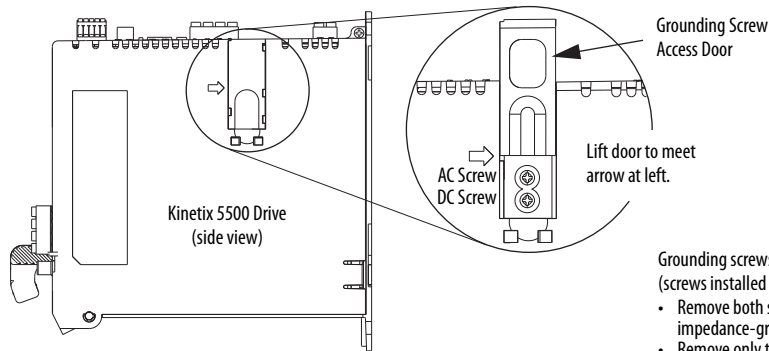

Grounding screws are installed for grounded power configurations (screws installed is default setting).

- Remove both screws for ungrounded, corner-grounded, and impedance-grounded power for three-phase operation
- Remove only the AC screw for single-phase operation



ATTENTION: Risk of equipment damage exists. The drive ground configuration must be accurately determined. Leave the grounding screws installed for grounded power configurations (default). Remove the screws for ungrounded, ungrounded, corner-grounded, and impedance-grounded power.

Grounding Screw Configurations

Ground Configuration ⁽¹⁾	Grounding Screw Configuration	Benefits of Configuration
Grounded (wye)	Both screws installed (default setting)	<ul style="list-style-type: none"> • UL and EMC compliance • Reduced electrical noise • Most stable operation • Reduced voltage stress on components and motor bearings
<ul style="list-style-type: none"> • AC fed ungrounded • Corner grounded • Impedance grounded 	Both screws removed	<ul style="list-style-type: none"> • Helps avoid severe equipment damage when ground faults occurs • Reduced leakage current
Single-phase input power	AC screw removed ⁽²⁾	Minimizes leakage current for single-phase operation

(1) Refer to the Kinetix 5500 Servo Drives User Manual, publication [2198-UM001](#), for example configurations.

(2) Removing the AC grounding screw to minimize leakage current in single-phase operation can affect EMC performance.

Install the Kinetix 5500 Servo Drive

These procedures assume that you have prepared your panel and understand how to bond your system. For installation instructions regarding equipment and accessories not included here, refer to the instructions that came with those products.



SHOCK HAZARD: To avoid hazard of electrical shock, perform all mounting and wiring of the Kinetix 5500 drive prior to applying power. Once power is applied, connector terminals can have voltage present even when not in use.



ATTENTION: Plan the installation of your system so that you can perform all cutting, drilling, tapping, and welding with the system removed from the enclosure. Because the system is of the open type construction, be careful to keep any metal debris from falling into it. Metal debris or other foreign matter can become lodged in the circuitry and result in damage to components.

Mount the Kinetix 5500 Drive

Follow these steps to mount the drive in single-axis configurations.

1. Observe these clearance requirements when mounting a single drive to the panel:
 - Additional clearance is required for cables and wires or the shared-bus connection system connected to the top of the drive.
 - Additional clearance is required if other devices are installed above and/or below the drive and have clearance requirements of their own.
 - Additional clearance left and right of the drive is required when mounted adjacent to noise sensitive equipment or clean wire ways.
 - The recommended minimum cabinet depth is 300 mm (11.81 in.).

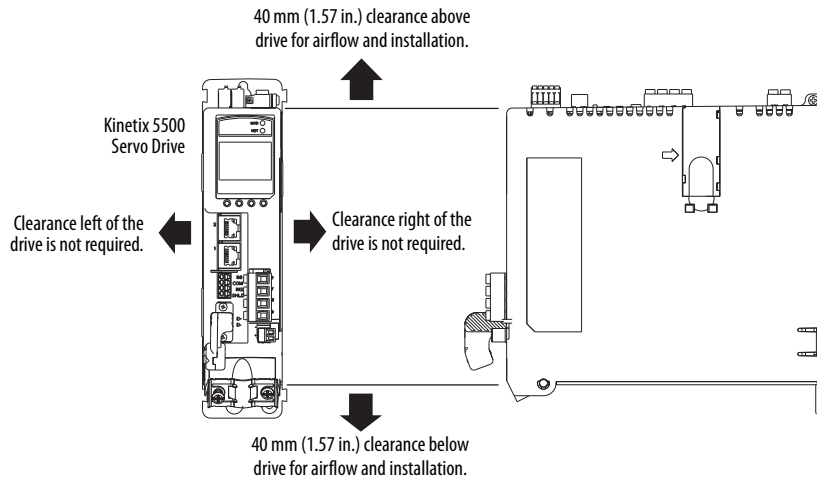

Refer to the Kinetix Servo Drives Technical Data, publication [GMC-TD003](#), for Kinetix 5500 drive dimensions.

IMPORTANT Mount the drive in an upright position as shown. Do not mount the drive on its side.

In multi-axis shared-bus configurations, drives must be spaced by aligning the zero-stack tab and cutout. For mounting, sizing, and configuring shared-bus configurations, refer to the Kinetix 5500 Servo Drives User Manual, publication [2198-UM001](#).

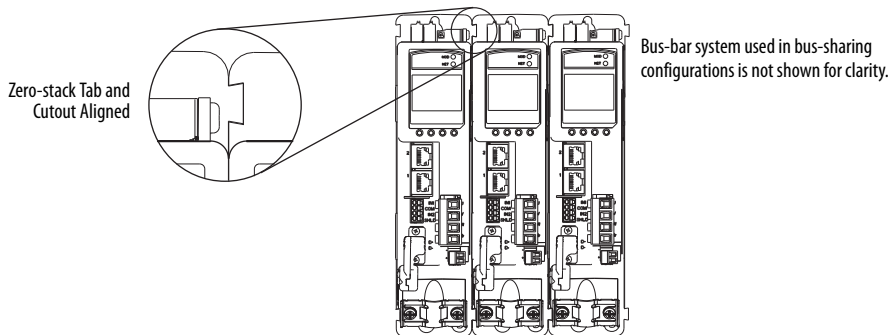

2. Mount the Kinetix 5500 drive to the cabinet subpanel with M4 (#8-32) steel machine screws torqued to 2.0 N•m (17.7 lb•in), max.

Product Dimensions

Included in this figure are the drill hole patterns for standalone drives. Refer to the Kinetix 5500 Servo Drives User Manual, publication [2198-UM001](#), for multi-axis drill-hole patterns.

Kinetix 5500 Drives with 2198-KITCON-DSL Connector Kit

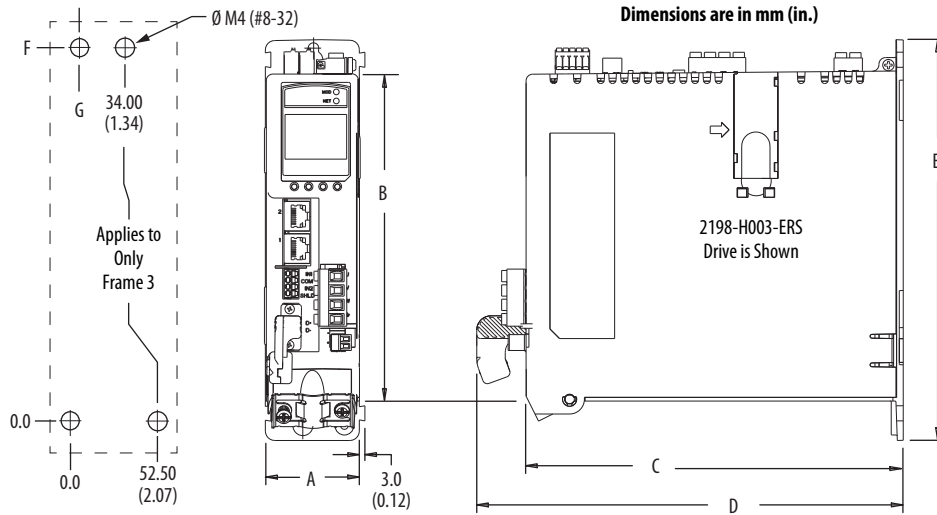

Kinetix 5500 Drive Cat. No.	Frame	A mm (in.)	B mm (in.)	C mm (in.)	D mm (in.)	E mm (in.)	Drill Hole Patterns	
							F mm (in.)	G mm (in.)
2198-H003-ERSx	1	50 (1.97)	170 (6.69)	200 (7.87)	226 (8.90)	215 (8.46)	193.68 (7.62)	4.51 (0.18)
2198-H008-ERSx								
2198-H015-ERSx	2	55 (2.16)	225 (8.86)	200 (7.87)	226 (8.90)	265 (10.43)	243.84 (9.60)	5.00 (0.20)
2198-H025-ERSx								
2198-H040-ERSx								
2198-H070-ERSx	3	85.2 (3.35)	250 (9.84)			294 (11.57)	273.70 (10.78)	0.0

Kinetix 5500 Drives with 2198-H2DCK Converter Kit

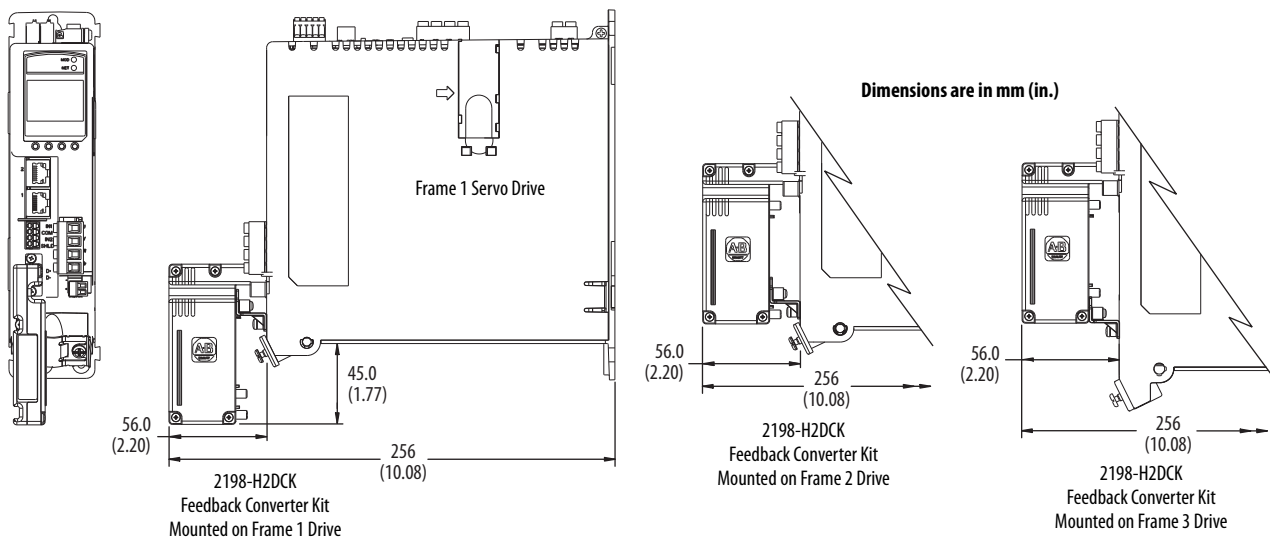

Refer to Kinetix Servo Drives Technical Data, publication [GMC-TD003](#), for motor/actuator compatibility with the 2198-H2DCK converter kit and product dimensions.

Connector Data

Use this illustration to identify the Kinetix 5500 drive features and indicators.

Kinetix 5500 Drive Features and Indicators

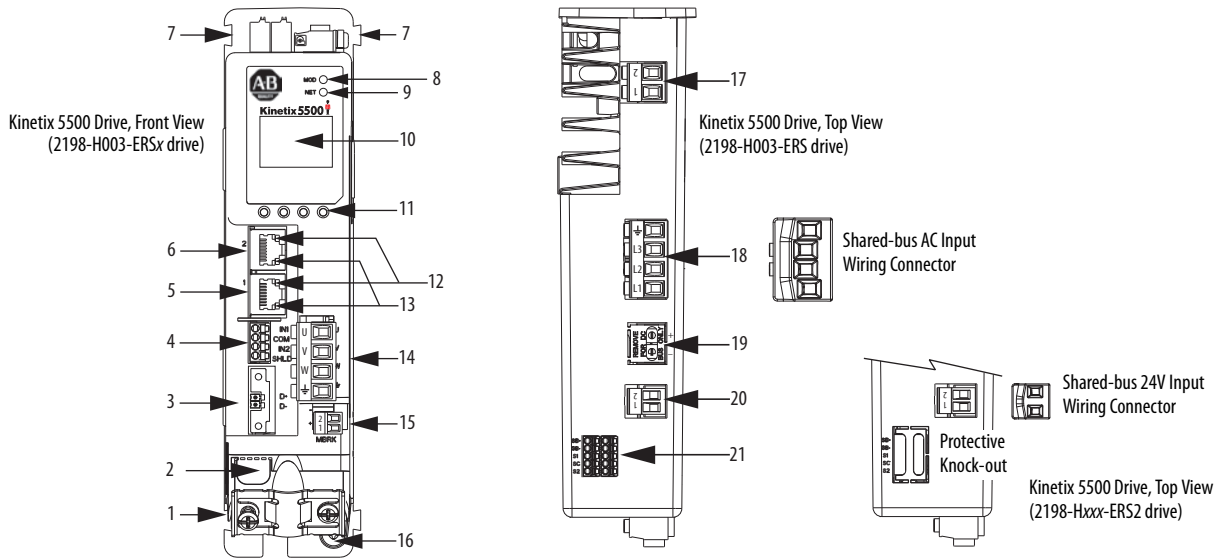

Item	Description
1	Motor cable shield clamp
2	Converter kit mounting hole (under cover) ⁽¹⁾
3	Motor feedback (MF) connector
4	Digital inputs (IOD) connector
5	Ethernet (PORT1) RJ45 connector
6	Ethernet (PORT2) RJ45 connector
7	Zero-stack mounting tab/cutout

Item	Description
8	Module status indicator
9	Network status indicator
10	LCD display
11	Navigation push buttons
12	Link speed status indicators
13	Link/Activity status indicators
14	Motor power (MP) connector



	Description
15	Motor brake (BC) connector
16	Ground terminal
17	Shunt resistor (RC) connector
18	AC mains input power (IPD) connector
19	DC bus (DC) connector (under cover) ⁽²⁾
20	24V control input power (CP) connector
21	Safe torque-off (STO) connector ⁽³⁾ (applies to only 2198-Hxxx-ERS drives)

- (1) Protective knock-out covers the 2198-H2DCK converter kit mounting hole. Remove knock-out for use with the converter kit.
- (2) DC bus connector ships with protective knock-out cover that can be removed for use in shared-bus configurations.
- (3) Protective knock-out cover is removed on 2198-Hxxx-ERS (hardwired STO) drives.

Kinetix 5500 Drive Connectors

Designator	Description	Connector
IPD	AC mains input power	4-position plug, terminal screws
DC	DC common bus power	2-position (T-connector used in shared-bus configurations)
CP	24V control input power	2-position plug, terminal screws
RC	Shunt power	2-position plug, terminal screws
MP	Motor power	4-position plug, terminal screws
MF	Motor feedback	2-position plug, spring terminals
BC	Brake power	2-position plug, terminal screws
IOD	Digital inputs	4-position plug, spring terminals
STO	Safe torque off	5-position plugs, spring terminals, 2x (2 rows of 5 pins)
PORT1, PORT2	Ethernet communication ports	RJ45 Ethernet

Mains Input Power (IPD) Connector

IPD Pin	Description	Signal
	Chassis ground	
L3	Three-phase input power	L3
L2		L2
L1		L1

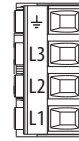
**Shunt Power (RC) Connector Pinout**

RC Pin	Description	Signal
1	Shunt connections (frames 2 and 3)	DC+
2		SH
1	Shunt connections (frame 1)	SH
2		DC+



**DC Bus (DC) Connector Pinout**

DC Pin	Description	Signal
1	DC bus connections	DC-
2		DC+

Control Input Power (CP) Connector Pinout

CP Pin	Description	Signal
1	24V power supply, customer-supplied	24V+
2	24V common	24V-

**Motor Power (MP) Connector Pinout**

MP Pin	Description	Signal	Color
U	Three-phase motor power	U	Brown
V		V	Black
W		W	Blue
	Chassis ground		Green

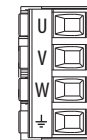
**Motor Feedback (MF) Connector Pinout**

MF Pin ⁽¹⁾	Description	Signal
1	Bidirectional data and power for digital encoder interface	D+
2		D-
SHIELD	Cable shield and grounding plate (internal to 2198-KITCON-DSL connector kit) termination point	SHIELD
	Cable shield and shield clamp (internal to 2198-H2DCK converter kit) termination point	

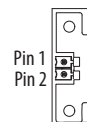

(1) Refer to Kinetix 5500 Servo Drives User Manual, publication [2198-UM001](#), for installation instructions.

Motor Brake (BC) Connector Pinout

BC Pin	Description	Signal
1	Motor brake connections	MBRK+
2		MBRK-



Digital Inputs (IOD) Connector Pinout

IOD Pin	Description	Signal
1	24V current-sinking fast input #1. This is a dual-function input.	IN1 ⁽¹⁾
2	I/O common for customer-supplied 24V supply.	COM
3	24V current-sinking fast input #2.	IN2
4	I/O cable shield termination point.	SHLD

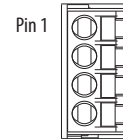

(1) This signal has dual-functionality. You can use IN1 (IOD-1) as registration or Home input.

Safe Torque Off (STO) Connector Pinout

STO Pin	Description	Signal
1	Safety bypass plus signal. Connect to both safety inputs to disable the STO function.	SB+
2	Safety bypass minus signal. Connect to safety common to disable the STO function.	SB-
3	STO input 1 (SS_IN_CH0).	S1
4	STO input common (SCOM).	SC
5	STO input 2 (SS_IN_CH1).	S2

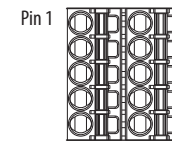

IMPORTANT The safe torque-off (STO) connector applies to only the 2198-Hxxx-ERS drives.

The 2198-Hxxx-ERS drives ship with the safe torque-off function enabled. Connect the safe torque-off inputs to a safety circuit or install bypass wiring to enable motion. Refer to the Kinetix 5500 Servo Drives User Manual, publication [2198-UM001](#), for more information.

Ethernet Communication PORT1 and PORT2 Pinout

Port Pin	Description	Signal
1	Transmit port (+) data terminal	TD+
2	Transmit port (-) data terminal	TD-
3	Receive port (+) data terminal	RD+
4	–	–
5	–	–
6	Receive port (-) data terminal	RD-
7	–	–
8	–	–

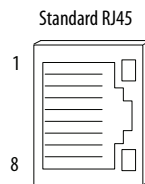



Wiring Requirements

Wire must be copper with 75 °C (167 °F) minimum rating. Phasing of mains AC power is arbitrary and earth ground connection is required for safe and proper operation.

IMPORTANT The National Electrical Code and local electrical codes take precedence over the values and methods provided.

Kinetix 5500 Drive Power and I/O Wiring Requirements

Kinetix 5500 Drive Cat. No.	Description	Connects to Terminals		Wire Size mm ² (AWG)	Strip Length mm (in.)	Torque Value N•m (lb•in)
		Pin	Signal			
2198-H003-ERSx 2198-H008-ERSx 2198-H015-ERSx 2198-H025-ERSx 2198-H040-ERSx	Mains input ⁽¹⁾ power (single-axis IPD connector)	IPD-1 IPD-2 IPD-3 IPD-4	L1 L2 L3 	1.5...4 (16...12)	7.0 (0.28)	0.5...0.6 (4.4...5.3)
2198-H070-ERSx				1.5...6 (16...10)	10.0 (0.39)	
2198-H003-ERSx 2198-H008-ERSx 2198-H015-ERSx 2198-H025-ERSx 2198-H040-ERSx	Motor power	MP-1 MP-2 MP-3 MP-4	 W V U	Motor power cable depends on motor/drive combination. 0.75...2.5 ⁽⁴⁾ (18...14)	8.0 (0.31)	0.5...0.6 (4.4...5.3)
2198-H070-ERSx				2.5...6 ⁽⁴⁾ (14...10)	10.0 (0.39)	
2198-Hxxx-ERSx	PELV/SELV 24V power (single-axis CP connector)	CP-1 CP-2	24V+ 24V-	2.5...0.5 (14...20)	7.0 (0.28)	0.22...0.25 (1.9...2.2)
	Brake power	BC-1 BC-2	MBRK+ MBRK-	N/A ⁽⁵⁾		
	DC Bus power	DC-1 DC-2	DC+ DC-	N/A ⁽⁶⁾	N/A ⁽⁶⁾	N/A ⁽⁶⁾
	Shunt power (frames 2 and 3)	RC-1 RC-2	DC+ SH	0.5...4.0 (20...12)	8.0 (0.31)	0.5...0.6 (4.4...5.3)
	Shunt power (frame 1)	RC-1 RC-2	SH DC+			
	Safety ⁽²⁾	STO-1 STO-2 STO-3 STO-4 STO-5	SB+ SB- S1 SC S2	0.2...1.5 (24...16)	10.0 (0.39)	N/A ⁽⁷⁾
	Digital inputs	IOD-1 IOD-2 IOD-3 IOD-4	IN1 ⁽³⁾ COM IN2 SHLD	0.2...1.5 (24...16)	10.0 (0.39)	N/A ⁽⁷⁾

(1) The wire size, strip length, and torque specifications shown here apply to the single-axis connector that ships with the drive. For the shared-bus connector specifications, refer to the Kinetix 5500 Servo Drives User Manual, publication [2198-UM001](#).

(2) These signals and the safe torque-off (STO) connector apply to only the 2198-Hxxx-ERS drives.

(3) This signal has dual-functionality. You can use IN1 (IOD-1) as registration or Home input.

(4) Building your own cables or using third-party cables is not an option. Use single motor cable catalog number 2090-CSxM1DF-xxAxx. Refer to the Kinetix Motion Accessories Specifications Technical Data, publication [KNX-TD004](#), for cable specifications.

(5) Motor brake wires are part of the 2090-CSBM1DF/DG motor cable.

(6) DC bus connections are always made from drive-to-drive over the bus bar connection system. These terminals do not receive discrete wires.

(7) This connector uses spring tension to hold wires in place.



ATTENTION: To avoid personal injury and/or equipment damage, observe the following:

- Make sure installation complies with specifications regarding wire types, conductor sizes, branch circuit protection, and disconnect devices. The National Electrical Code (NEC) and local codes outline provisions for safely installing electrical equipment.
- Use motor power connectors only for connection purposes. Do not use them to turn the unit on and off.
- Ground shielded power cables to prevent potentially high voltages on the shield.

Attach the Motor Cable Shield Clamp

A shield clamp and two screws are supplied with each Kinetix 5500 drive. Use the clamp to bond the motor cable shield-braid to chassis ground.

- IMPORTANT**
- Loosen the retention screw, if needed, until you can start threading both clamp screws with the cable shield under the clamp.
 - Make sure the cable clamp tightens around the cable shield and provides a good bond between the cable shield and the drive chassis.

Kinetix VP Servo Motors

These examples illustrate 2090-CSxM1DF/DG motor cables with connections to Kinetix VP motors and using 2198-KITCON-DSL feedback connector kits. If your motor connections are coming from other compatible Allen-Bradley® servo motors/actuators, see [Other Allen-Bradley Motors and Actuators](#) on [page 11](#).

Cable Shield Clamp Installation

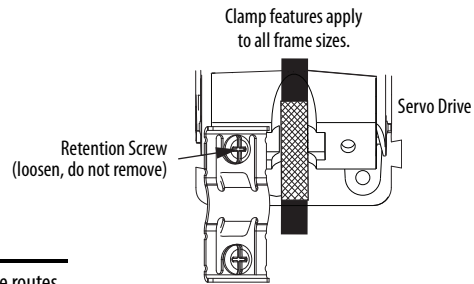
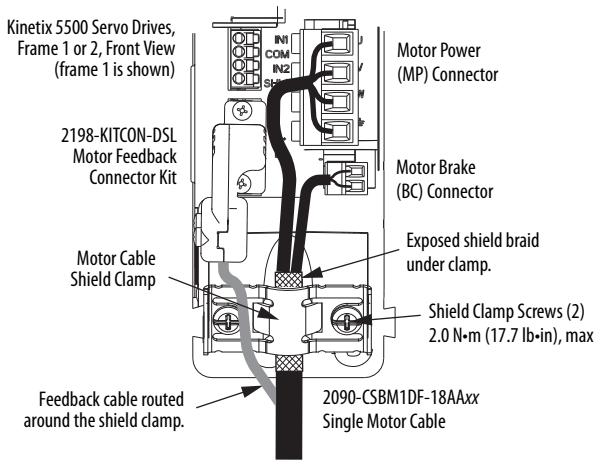

- IMPORTANT** When the drive/motor combination calls for 18 AWG cable, the feedback cable routes around the motor cable shield clamp.

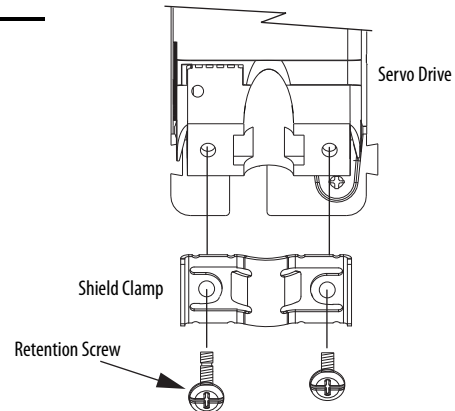
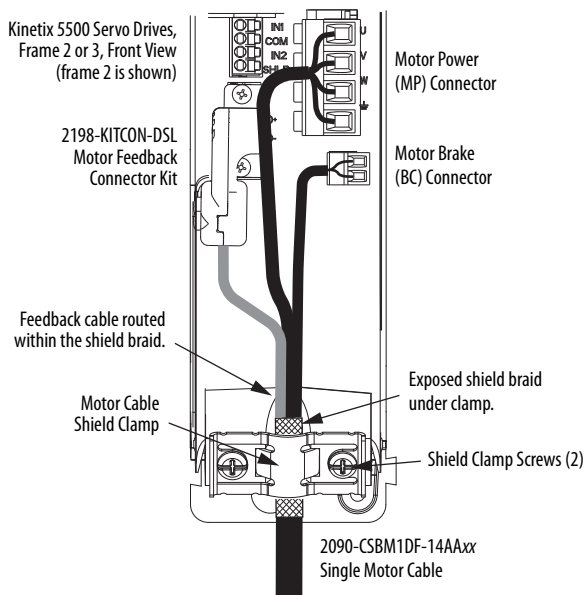

- IMPORTANT** When the drive/motor combination calls for 14 or 10 AWG cable, the feedback cable routes along with the power and brake wiring.

Other Allen-Bradley Motors and Actuators

The other compatible Allen-Bradley motors and actuators require the 2198-H2DCK converter kit for wiring motor feedback. A clamp spacer is included with the kit for motor power/brake cable diameters that are too small for a tight fit within the drive clamp alone.

IMPORTANT If the power/brake cable shield has a loose fit inside the shield clamp, insert the clamp spacer between the shield clamp and the drive to reduce the clamp diameter. When the clamp screws are tight, 2.0 N·m (17.7 lb-in), the result must be a high-frequency bond between the cable shield and the drive chassis.

Cable Clamp Attachment

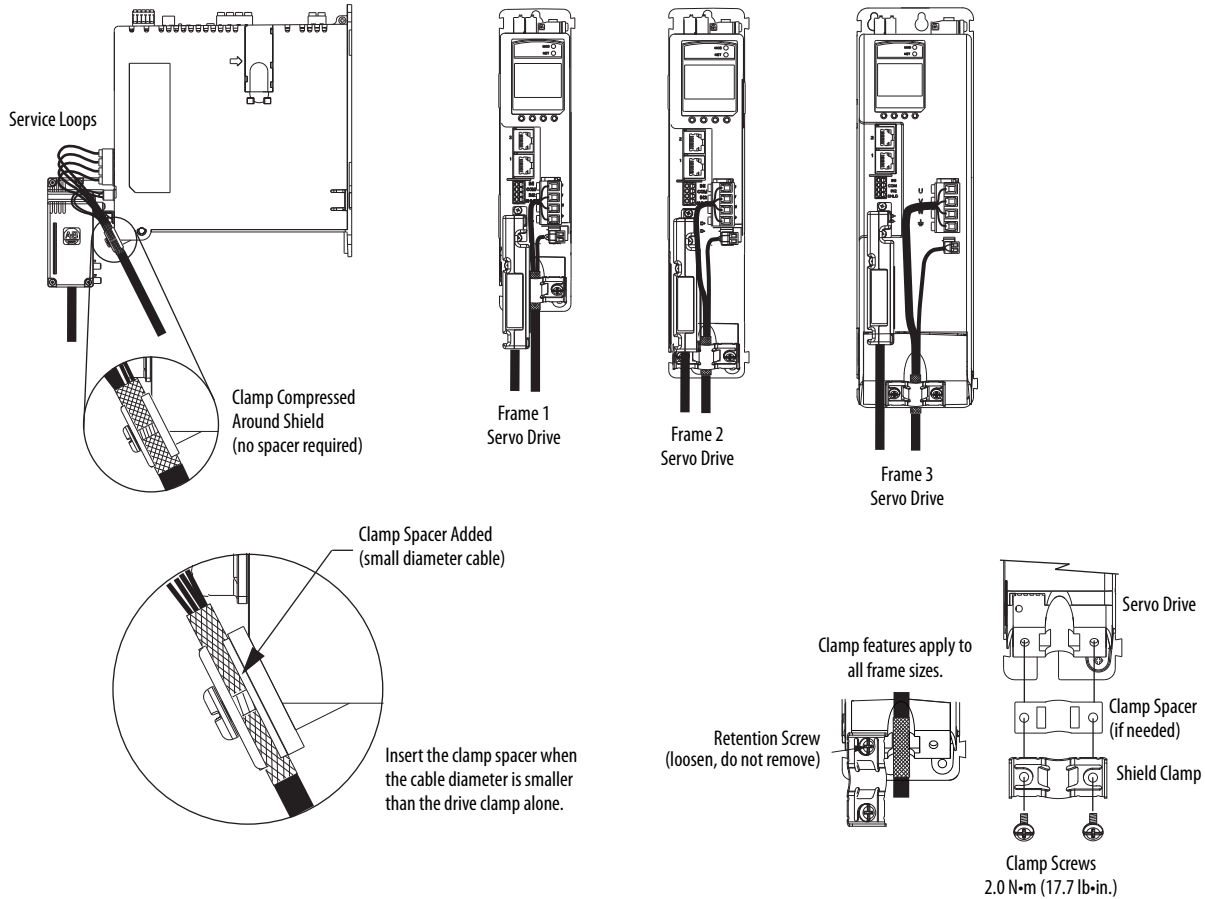

Refer to the Kinetix 5500 Servo Drives User Manual, publication [2198-UM001](#), for detailed information on wiring the 2198-H2DCK feedback converter kit and attaching the motor power/brake shield clamp.

Ground Your Kinetix 5500 Drive to the Subpanel

Ground Kinetix 5500 drives and 2198-CAPMOD-1300 capacitor modules to a bonded cabinet ground bus with a braided ground strap. Keep the braided ground strap as short as possible for optimum bonding.

Connecting the Braided Ground Strap

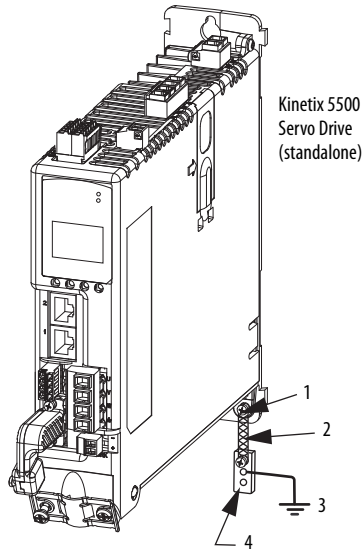

Item	Description
1	Ground screw (green) 2.0 N·m (17.5 lb-in), max
2	Braided ground strap (customer supplied)
3	Ground grid or power distribution ground
4	Bonded cabinet ground bus (customer supplied)

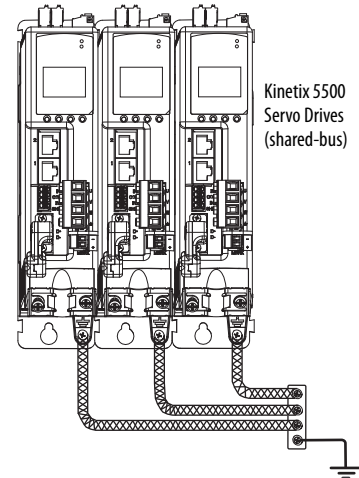

Refer to the System Design for Control of Electrical Noise Reference Manual, publication [GMC-RM001](#), for more information.

Circuit Breaker/Fuse Selection

The Kinetix 5500 drives use internal solid-state motor short-circuit protection and, when protected by suitable branch circuit protection, are rated for use on a circuit capable of delivering up to 200,000 A (fuses) and 65,000 A (circuit breakers).

Standalone Drive Systems

Drive Cat. No.	Kinetix 5500 Drives		UL Applications		IEC (non-UL) Applications	
	Drive Voltage, nom	Phase	Bussmann Fuses Cat. No.	Molded Case CB Cat. No.	DIN gG Fuses Amps (max)	Molded Case CB Cat. No.
2198-H003-ERSx	240V	Single-phase	KTK-R-2	140U-D6D2-B10	2	140U-D6D2-B10
	240/480V	Three-phase	KTK-R-3	140U-D6D3-B20	4	140U-D6D3-B20
2198-H008-ERSx	240V	Single-phase	KTK-R-5	140U-D6D2-B20	6	140U-D6D2-B20
	240/480V	Three-phase	KTK-R-7	140U-D6D3-B60	6	140U-D6D3-B60
2198-H015-ERSx	240V	Single-phase	KTK-R-10	140U-D6D2-B80	10	140U-D6D2-B80
	240/480V	Three-phase	KTK-R-15	140U-D6D3-C12	16	140U-D6D3-C12
2198-H025-ERSx	240/480V	Three-phase	KTK-R-20	140U-D6D3-C20	20	140U-D6D3-C20
2198-H040-ERSx	240/480V	Three-phase	KTK-R-25	140U-D6D3-C25	25	140U-D6D3-C25
2198-H070-ERSx	240/480V	Three-phase	LPJ-35SP	140G-G6C3-C40	35	140G-G6C3-C40

Shared DC (common-bus) Drive Systems

Kinetix 5500 Drive Cat. No.	Drive Voltage, (three-phase) nom	UL Applications		IEC (non-UL) Applications	
		Bussmann Fuses Cat. No.	Molded Case CB Cat. No.	DIN gG Fuses Amps (max)	Molded Case CB Cat. No.
2198-H003-ERSx	240/480V	KTK-R-10	N/A	10	N/A
2198-H008-ERSx	240/480V	KTK-R-10	N/A	10	N/A
2198-H015-ERSx	240/480V	KTK-R-15	140U-D6D3-C15	16	140U-D6D3-C15
2198-H025-ERSx	240/480V	KTK-R-20	140U-D6D3-C20	20	140U-D6D3-C20
2198-H040-ERSx	240/480V	KTK-R-25	140U-D6D3-C25	25	140U-D6D3-C25
2198-H070-ERSx	240/480V	LPJ-35SP	140G-G6C3-C40	35	140G-G6C3-C40

Shared AC Drive Systems

Input Power UL Circuit-protection Specifications

Kinetix 5500 Drive Cat. No.	Drive Voltage, (three-phase) nom	Bussmann Fuses Cat. No.				Molded Case CB Cat. No.			
		2 Axes	3 Axes	4 Axes	5 Axes	2 Axes	3 Axes	4 Axes	5 Axes
2198-H003-ERSx	240/480V	KTK-R-15				N/A			
2198-H008-ERSx	240/480V	KTK-R-15				N/A			
2198-H015-ERSx	240/480V	KTK-R-20	KTK-R-25	N/A		140U-D6D3-C15	140U-D6D3-C20	N/A	
2198-H025-ERSx	240/480V	KTK-R-30		N/A		140U-D6D3-C25	140U-D6D3-C30	N/A	
2198-H040-ERSx	240/480V	LPJ-35SP	LPJ-45SP	N/A		N/A			
2198-H070-ERSx	240/480V	LPJ-60SP	N/A			140G-G6C3-C60	N/A		

Input Power IEC (non-UL) Circuit-protection Specifications

Kinetix 5500 Drive Cat. No.	Drive Voltage, (three-phase) nom	DIN gG Fuses Amps (max)				Molded Case CB Cat. No.			
		2 Axes	3 Axes	4 Axes	5 Axes	2 Axes	3 Axes	4 Axes	5 Axes
2198-H003-ERSx	240/480V	16				N/A			
2198-H008-ERSx	240/480V	16				N/A			
2198-H015-ERSx	240/480V	20	25	N/A		140U-D6D3-C15	140U-D6D3-C20	N/A	
2198-H025-ERSx	240/480V	32		N/A		140U-D6D3-C25	140U-D6D3-C30	N/A	
2198-H040-ERSx	240/480V	35	N/A			N/A			
2198-H070-ERSx	240/480V	63	N/A			140G-G6C3-C60	N/A		

Shared AC/DC and Hybrid Systems

Input Power UL Circuit-protection Specifications

Kinetix 5500 Drive Cat. No.	Drive Voltage, (three-phase) nom	Bussmann Fuse Cat. No.						Molded Case CB Cat. No.							
		2 Axes	3 Axes	4 Axes	5 Axes	6 Axes	7 Axes	8 Axes	2 Axes	3 Axes	4 Axes	5 Axes	6 Axes	7 Axes	8 Axes
2198-H003-ERSx	240/480V	KTK-R-10				KTK-R-15		N/A							
2198-H008-ERSx	240/480V	KTK-R-15			KTK-R-20			N/A							
2198-H015-ERSx	240/480V	KTK-R-20		N/A				140U-D6D3-C15		140U-D6D3-C20		N/A			
2198-H025-ERSx	240/480V	KTK-R-30		N/A				140U-D6D3-C20		140U-D6D3-C30		N/A			
2198-H040-ERSx	240/480V	KTK-R-30	LPI-45SP	LPI-50SP	N/A			140U-D6D3-C30		N/A					
2198-H070-ERSx	240/480V	LPI-50SP	N/A				140G-G6C3-C50		N/A						

Input Power IEC (non-UL) Circuit-protection Specifications

Kinetix 5500 Drives Cat. No.	Drive Voltage, (three-phase) nom	DIN gG Fuses Amps (max)						Molded Case CB Cat. No.							
		2 Axes	3 Axes	4 Axes	5 Axes	6 Axes	7 Axes	8 Axes	2 Axes	3 Axes	4 Axes	5 Axes	6 Axes	7 Axes	8 Axes
2198-H003-ERSx	240/480V	10				16		N/A							
2198-H008-ERSx	240/480V	16			N/A			N/A							
2198-H015-ERSx	240/480V	20		N/A				140U-D6D3-C15		140U-D6D3-C20		N/A			
2198-H025-ERSx	240/480V	32		N/A				140U-D6D3-C20		140U-D6D3-C30		N/A			
2198-H040-ERSx	240/480V	32	N/A				140U-D6D3-C30		N/A						
2198-H070-ERSx	240/480V	50	N/A				140G-G6C3-C50		N/A						

Motor Overload Protection

This servo drive uses solid-state motor overload protection that operates in accordance with UL requirements. Motor overload protection is provided by algorithms (thermal memory) that predict actual motor temperature that is based on operating conditions.

In addition to thermal memory protection, this drive provides an input for an external temperature sensor/thermistor device, embedded in the motor, to support the UL requirement for motor overload protection.

Servo drives using DSL (digital servo link) encoder technology require the encoder to perform motor temperature monitoring and transmit the data over the single motor cable. Kinetix VP motors use DSL technology that performs this function. No additional wiring is required.

Some motors supported by this drive (firmware revision 3.001 or earlier) do not contain temperature sensors/thermistors; therefore, motor overload protection against excessive consecutive motor overloads with power cycling is not supported. Beginning with firmware revision 4.001 (and later) thermal retention is supported regardless of the motor or encoder type in use.

This servo drive meets the following UL requirements for solid-state overload protection.

Motor Overload Protection Trip Point	Value
Ultimately	100% overload
Within 8 minutes	200% overload
Within 20 seconds	600% overload



ATTENTION: To avoid damage to your motor due to overheating caused by excessive, successive motor overload trips, follow the wiring diagram provided in the user manual for your motor and drive combination.

Refer to your servo drive user manual for the interconnect diagram that illustrates the wiring between your motor and drive.

Additional Resources

These documents contain additional information concerning related products from Rockwell Automation.

Resource	Description
Kinetix 5500 Servo Drives User Manual, publication 2198-UM001	Information on installing, configuring, starting, and troubleshooting your Kinetix 5500 servo drive system.
Kinetix Servo Drives Specifications Technical Data, publication GMC-TD003	Provides product specifications for the Kinetix Integrated Motion over EtherNet/IP network, Integrated Motion over sercos interface, EtherNet/IP networking, and component servo drive families.
Kinetix Motion Accessories Specifications Technical Data, publication KNX-TD004	Provides product specifications for Bulletin 2090 motor and interface cables, low-profile connector kits, drive power components, and other servo drive accessory items.
Kinetix 5500 Feedback Connector Kit Installation Instructions, publication 2198-IN002	Information on installing and wiring the Kinetix 5500 motor feedback connector kit.
Kinetix 5000 AC Line Filter Installation Instructions, publication 2198-IN003	Information on installing and wiring the Kinetix 5500 AC line filters.
Hiperface-to-DSL Feedback Converter Kit Installation Instructions, publication 2198-IN006	Information on installing and wiring the Hiperface-to-DSL feedback converter kit.
Kinetix 300 Shunt Resistor Installation Instructions, publication 2097-IN002	Information on installing and wiring these external shunt resistors for your Kinetix 5500 servo drives.
Industrial Automation Wiring and Grounding Guidelines, publication 1770-4.1	Provides general guidelines for installing a Rockwell Automation® industrial system.
Product Certifications website, http://www.ab.com	Provides declarations of conformity, certificates, and other certification details.

You can view or download publications at <http://www.rockwellautomation.com/global/literature-library/overview.page>. To order paper copies of technical documentation, contact your local Allen-Bradley distributor or Rockwell Automation sales representative.

Rockwell Automation Support

Use the following resources to access support information.

Technical Support Center	Knowledgebase Articles, How-to Videos, FAQs, Chat, User Forums, and Product Notification Updates.	https://rockwellautomation.custhelp.com/
Local Technical Support Phone Numbers	Locate the phone number for your country.	http://www.rockwellautomation.com/global/support/get-support-now.page
Direct Dial Codes	Find the Direct Dial Code for your product. Use the code to route your call directly to a technical support engineer.	http://www.rockwellautomation.com/global/support/direct-dial.page
Literature Library	Installation Instructions, Manuals, Brochures, and Technical Data.	http://www.rockwellautomation.com/global/literature-library/overview.page
Product Compatibility and Download Center (PCDC)	Get help determining how products interact, check features and capabilities, and find associated firmware.	http://www.rockwellautomation.com/global/support/pcdc.page

Documentation Feedback

Your comments will help us serve your documentation needs better. If you have any suggestions on how to improve this document, complete the How Are We Doing? form at http://literature.rockwellautomation.com/idc/groups/literature/documents/du/ra-du002_-en-e.pdf.

Rockwell Automation maintains current product environmental information on its website at <http://www.rockwellautomation.com/rockwellautomation/about-us/sustainability-ethics/product-environmental-compliance.page>.

Allen-Bradley, CompactLogix, ControlLogix, GuardLogix, Kinetix, Rockwell Automation, and Rockwell Software are trademarks of Rockwell Automation, Inc. Trademarks not belonging to Rockwell Automation are property of their respective companies.

Rockwell Otomasyon Ticaret A.Ş., Kar Plaza İş Merkezi E Blok Kat:6 34752 İçerenköy, İstanbul, Tel: +90 (216) 5698400

www.rockwellautomation.com

Power, Control and Information Solutions Headquarters

Americas: Rockwell Automation, 1201 South Second Street, Milwaukee, WI 53204-2496 USA, Tel: (1) 414.382.2000, Fax: (1) 414.382.4444
Europe/Middle East/Africa: Rockwell Automation NV, Pegasus Park, De Kleetlaan 12a, 1831 Diegem, Belgium, Tel: (32) 2 663 0600, Fax: (32) 2 663 0640
Asia Pacific: Rockwell Automation, Level 14, Core F, Cyberport 3, 100 Cyberport Road, Hong Kong, Tel: (852) 2887 4788, Fax: (852) 2508 1846



PN-352058

Publication 2198-IN001D-EN-P - February 2016

Supersedes Publication 2198-IN001C-EN-P - January 2014

Copyright © 2016 Rockwell Automation, Inc. All rights reserved. Printed in the U.S.A.