

Power Terminal Block

Figure 1.2 Typical Power Terminal Block Location (B Frame Shown)

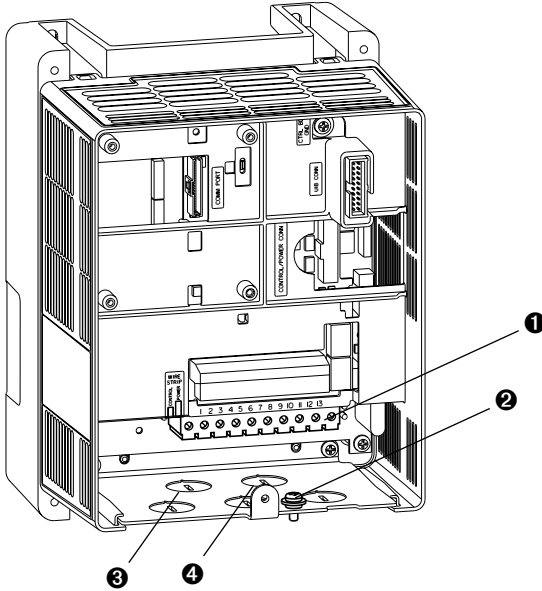

Table 1.A Power Terminal Block Specifications

No.	Name	Description	Frame	Wire Size Range ⁽¹⁾		Torque
				Maximum	Minimum	
1	Power Terminal Block	Input power and motor connections	A, B, & C	3.5 mm ² (12 AWG)	0.3 mm ² (22 AWG)	0.6 N-m (5 lb.-in.)
			D	8.4 mm ² (8 AWG)	0.8 mm ² (18 AWG)	1.4 N-m (12 lb.-in.)
2	SHLD terminal	Terminating point for wiring shields	All	—	—	1.6 N-m (14 lb.-in.)

(1) Maximum/minimum sizes that the terminal block will accept - these are not recommendations.

Table 1.B Wire Routing Recommendations

No.	Description
3	Suggested entry for incoming line wiring.
4	Suggested entry for motor wiring.

Figure 1.3 Power Terminal Block and DC Bus Test Points

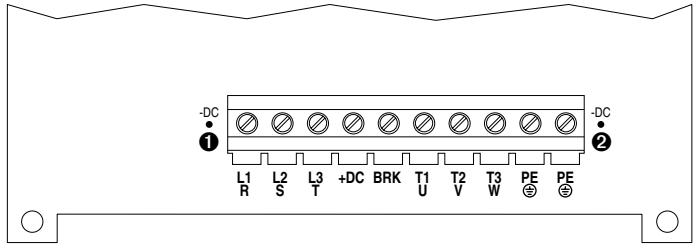

Terminal	Description	Notes
R	R (L1)	AC Line Input Power
S	S (L2)	AC Line Input Power
T	T (L3)	AC Line Input Power
+DC	DC Bus (+)	Dynamic Brake Resistor Connection (+)
BRK	DC Brake	Dynamic Brake Resistor Connection (-)
U	U (T1)	To Motor
V	V (T2)	To Motor
W	W (T3)	To Motor
PE	PE Ground	
PE	PE Ground	

DC Bus Test Points

-DC Test Point	Description	Notes
①	DC Bus (-)	Location on A and B Frame drives
②	DC Bus (-)	Location on C and D Frame drives

Figure 1.4 Power Input Terminals on the Internal RFI Filter Option

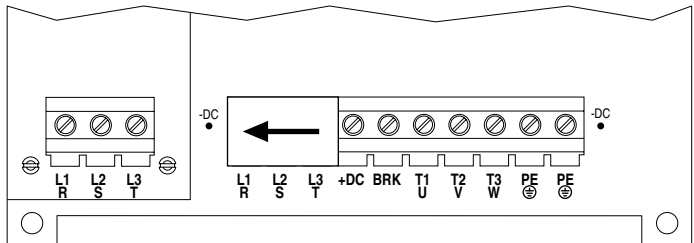

Cable Entry Plate Removal

If additional wiring access is needed, the Cable Entry Plate on all drive Frames can be removed. Simply loosen the screws securing the plate to the heat sink and slide the plate out.