

Shaft Seal Kits

Catalog Numbers

VPL-SSN, VPL-SS, VPC-SSN, VPF-SSN, VPH-SST, MPL-SSN, MPF-SST, MPS-SST, TL-SSN

Topic	Page
Summary of Changes	1
About Shaft Seals	2
Required Tools	2
Remove the Shaft Seal	3
Replace the Shaft Seal	4
Shaft Seal Kit Catalog Numbers	6
Additional Resources	8

Summary of Changes

This publication contains new and updated information as indicated in the following table.

Topic	Page
Updated the shaft seal remove and replace procedures.	3, 4
Added Kinetix® VP hygienic servo motors to the Shaft Seal Installation Clearances figure and table.	5
Added Kinetix VP hygienic servo motors to the Shaft Seal Kit Catalog Numbers table.	7

About Shaft Seals

A shaft seal is recommended if the motor shaft and end bell are exposed to significant amounts of containments, such as oil, fluids, or fine dust. Use a shaft seal in these environments to prolong the life of the motor. A shaft seal and Bulletin 2090 cables with environmentally sealed connectors are required for an IP66 rating or greater.

See Kinetix Motion Accessories Specifications Technical Data, publication [KNX-TD004](#), to find Bulletin 2090 cables with environmentally sealed connectors for your motor.

IMPORTANT The shaft seal is not required in applications where the motor shaft and end bell are free of oil, fluids, or fine dust, and a lower IP rating is sufficient.

Shaft seals are subject to wear and require periodic inspection and replacement. Replacement is recommended every 3 months, not to exceed 12 months, depending on use.

If you paint the motor, do not get paint on the shaft seal area or the shaft, as this can decrease the life of the shaft seal.

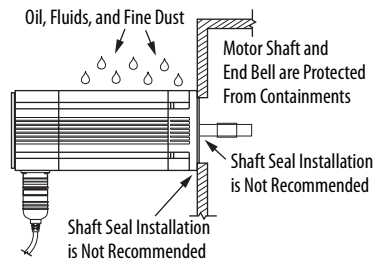
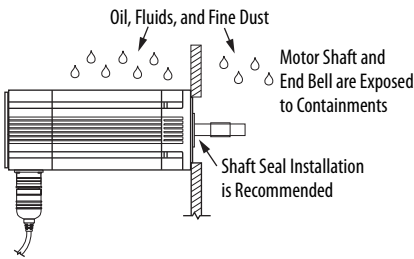

Required Tools

Use these tools to install a shaft seal:

- Appropriately sized screw or bolt to grip and remove the worn shaft seal
- Rubber/wooden mallet or a metal hammer and wooden work piece
- Socket, pipe, or tubing (various sizes)
- Abrasive cloth to remove any nicks or burrs from the motor shaft

Remove the Shaft Seal



ATTENTION: To avoid injury or damage to the equipment, remove power from the motor before removing the shaft seal.

The shaft seal can be safely removed by partially inserting an appropriately sized screw or bolt into the face of the shaft seal. The head of the screw or bolt provides a convenient point to grasp and remove the shaft seal.

Before installing the screw, create a pilot hole appropriate for the screw being used. Use masking tape or a depth sleeve to establish a drilling depth limit of 4 mm (0.16 in.) from the tip of the drill bit.



ATTENTION: Do not drill into the shaft seal deeper than 4 mm (0.16 in.). Drilling and inserting a screw completely through the shaft seal can damage the motor bearings, and require factory service to repair the motor.

Follow these steps to remove the shaft seal.

1. Remove power to the motor before removing the shaft seal.
2. Drill a pilot hole in the face of the shaft seal less than the depth limit specified above. Make sure the drill does not come in contact with the shaft seal bore.
3. Thread your screw or bolt into the pilot hole.
4. Lift the shaft seal from the motor by grasping the screw head and slightly rotating the seal while pulling.
5. Inspect and clean the shaft and sealing surfaces as necessary.

Use an abrasive cloth to remove any nicks or burrs from the motor shaft.

IMPORTANT Cover the sharp edges of the keyway with tape to protect the shaft seal lip from damage.

Replace the Shaft Seal

Follow these steps to replace the shaft seal.

1. Apply tape to the keyway opening so the edges do not damage the seal lip.
2. Lubricate the motor shaft and the inner lip of the shaft seal with lubricant that is supplied in the kit.

IMPORTANT Shaft seals require a lubricant to reduce wear. The lubricant is supplied with the shaft seal kits. Lubricate only the inner lip of the shaft seal. Do not lubricate the motor bore or outside diameter of the seal.

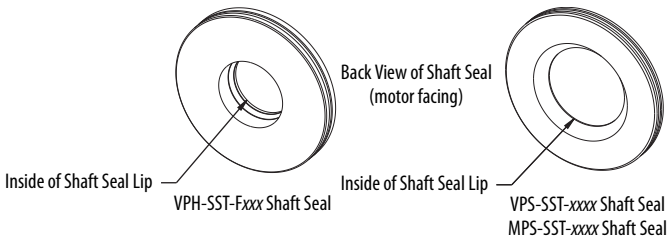

3. Center the shaft seal on the mounting surface of the motor and slide the shaft seal evenly onto the motor shaft.

See [Shaft Seal Installation Clearances](#) on [page 5](#) for the correct installation clearance of the shaft seal you are installing.

4. Press the shaft seal into the seal bore by applying one of the [Shaft Seal Installation Methods](#) on [page 6](#).
5. Visually inspect for irregularities in the shaft seal or an uneven alignment where the shaft seal contacts the motor.

Verify that the outer and inner circumference of the shaft seal is fully seated into position.

6. Verify that the shaft seal is installed to the correct installation clearance.
 - If the shaft seal is installed too deep, it can become subject to excessive wear and require frequent replacement.
 - If the shaft seal is installed too shallow, it can reduce the effectiveness of the protective seal.

Shaft Seal Installation Clearances

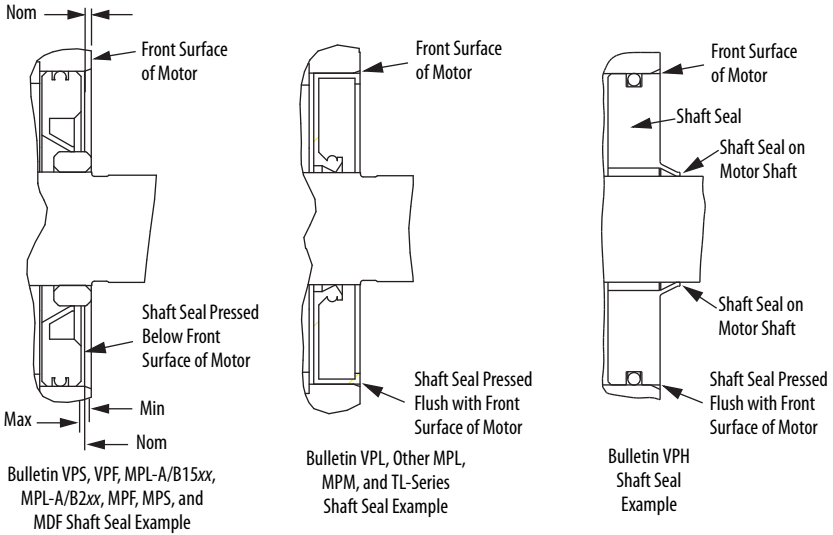

Motor Cat. No.	Shaft Seal Installation Clearance		
	Min, mm (in.)	Nom, mm (in.)	Max, mm (in.)
VPL-Axxx and VPL-Bxxx	Press the shaft seal so that the seal is flush or below the front surface of the motor.		
VPC-Bxxx			
VPF-Axxx and VPF-Bxxx	1.40 (0.055)	1.50 (0.060)	1.65 (0.065)
VPS-Bxxx			
VPH-Axxx and VPH-Bxxx	Press the shaft seal so that the seal is flush with the front surface of the motor.		
MPL-A15xx and MPL-B15xx	1.50 (0.060)	2.00 (0.080)	3.00 (0.120)
MPL-A2xx and MPL-B2xx			
All other MPL-A/Bxxx	Press the shaft seal so that the seal is flush or below the front surface of the motor.		
MPM-Axxx and MPM-Bxxx			
MPF-Axxx and MPF-Bxxx	1.40 (0.055)	1.50 (0.060)	1.65 (0.065)
MPS-Axxx and MPS-Bxxx			
MDF-SBxxx	1.40 (0.055)	1.50 (0.060)	1.65 (0.065)
TL-Series	Press the shaft seal so that the seal is flush or below the front surface of the motor.		

Shaft Seal Installation Methods



ATTENTION: Do not hammer directly on the shaft seal. Gently tap the socket, pipe, or tubing evenly around the outer edge of the shaft seal until the shaft seal is pressed into place. Make sure the socket, pipe, or tubing you use does not contact the shaft seal lip. Permanent damage to the shaft seal can occur.

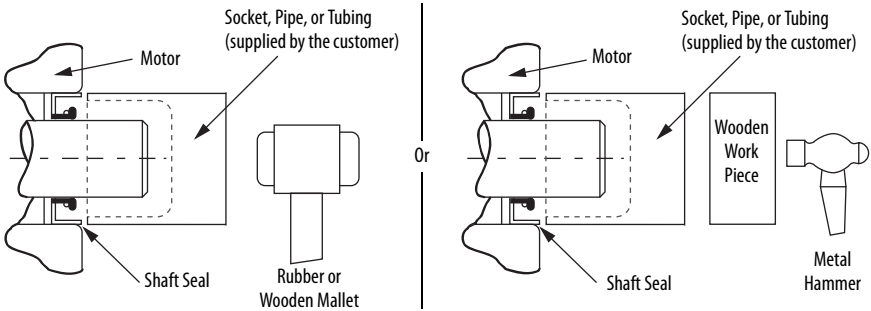

Shaft Seal Kit Catalog Numbers

IMPORTANT Third-party shaft seals are not approved for use with these motors. The use of third-party shaft seals voids any implied or expressed warranties.

Kinetix VP Low Inertia Motors

Motor Cat. No.	Shaft Seal Kit Cat. No.
VPL-A063xx and VPL-B063xx	VPL-SSN-F063075
VPL-A075xx and VPL-B075xx	
VPL-A100xx and VPL-B100xx	MPL-SSN-A3B3
VPL-A115xx and VPL-B115xx	MPL-SSN-A4B4
VPL-A130xx and VPL-B130xx	MPL-SSN-A5B5
VPL-B165xx	MPL-SSN-F165

Kinetix VP Continuous Duty Motors

Motor Cat. No.	Shaft Seal Kit Cat. No.
VPC-B165xx	MPL-SSN-A6B6
VPC-B215xx	VPL-SS-X256
VPC-B300xx	VPC-SSN-F300

Kinetix VP Food Grade Motors

Motor Cat. No.	Shaft Seal Kit Cat. No.
VPF-A063xx and VPF-B063xx	VPF-SSN-F063075
VPF-A075xx and VPF-B075xx	
VPF-A100xx and VPF-B100xx	MPF-SST-A3B3
VPF-A115xx and VPF-B115xx	MPF-SST-A4B4
VPF-A130xx and VPF-B130xx	MPF-SST-A45B45
VPF-B165xx	MPF-SST-F165

Kinetix VP Stainless Steel Motors

Motor Cat. No.	Shaft Seal Kit Cat. No.
VPS-B1304D	MPS-SST-A45B45
VPS-B1653D	MPS-SST-F165

Kinetix VP Hygienic Servo Motors

Motor Cat. No.	Shaft Seal Kit Cat. No.
VPH-A063xx and VPH-B063xx	VPH-SST-F063
VPH-A075xx and VPH-B075xx	VPH-SST-F075
VPH-A100xx and VPH-B100xx	VPH-SST-F100
VPH-A115xx and VPH-B115xx	VPH-SST-F115
VPH-A130xx and VPH-B130xx	VPH-SST-F130
VPH-B165xx	VPH-SST-F165

MP-Series Low Inertia Motors

Motor Cat. No.	Shaft Seal Kit Cat. No.
MPL-A15xx and MPL-B15xx	MPL-SSN-F63F75
MPL-A2xx and MPL-B2xx	
MPL-A3xx and MPL-B3xx	MPL-SSN-A3B3
MPL-A4xx and MPL-B4xx	MPL-SSN-A4B4
MPL-A45xx and MPL-B45xx	MPL-SSN-A5B5
MPL-A520 and MPL-B520 MPL-A540 and MPL-B540 MPL-A560 and MPL-B560	MPL-SSN-F165
MPL-B580	MPL-SSN-F165-32MM
MPL-B6xx	MPL-SSN-A6B6
MPL-B8xx	MPL-SSN-A8B8
MPL-B9xx	MPL-SSN-A9B9

MP-Series Food Grade Motors

Motor Cat. No.	Shaft Seal Kit Cat. No.
MPF-A3xx and MPF-B3xx	MPF-SST-A3B3
MPF-A4xx and MPF-B4xx	MPF-SST-A4B4
MPF-A45xx and MPF-B45xx	MPF-SST-A45B45
MPF-A5xx and MPF-B5xx	MPF-SST-F165

MP-Series Stainless Steel Motors

Motor Cat. No.	Shaft Seal Kit Cat. No.
MPS-A3xx and MPS-B3xx	MPS-SST-A3B3
MPS-A45xx and MPS-B45xx	MPS-SST-A45B45
MPS-B5xx	MPS-SST-F165

MP-Series Medium Inertia Motors

Motor Cat. No.	Shaft Seal Kit Cat. No.
MPM-A115x, MPM-B115xx	MPL-SSN-A4B4
MPM-A130xx, MPM-B130xx	MPL-SSN-A5B5
MPM-A165xx, MPM-B165xx	MPL-SSN-F165
MPM-A215xx, MPM-A215xx	MPL-SSN-A6B6

Kinetix 6000M Integrated Drive-Motor

Motor Cat. No.	Shaft Seal Kit Cat. No.
MDF-SB1003	MPF-SST-A3B3
MDF-SB1153	MPF-SST-A4B4
MDF-SB1304	MPF-SST-A45B45

TL-Series Low Inertia Motors

Motor Cat. No.	Shaft Seal Kit Cat. No.
TLY-A1xx and TL-A1xx	TL-SSN-1
TLY-A2xx and TL-A2xx	TL-SSN-2
TLY-A25xx and TL-A25xx	TL-SSN-3
TLY-A3xx	
TL-A4xx	TL-SSN-4

Additional Resources

These documents contain additional information concerning related products from Rockwell Automation.

Resource	Description
Kinetix Rotary Motion Specifications Technical Data, publication KNX-TD001	Product specifications for Kinetix VP (Bulletin VPL, VPC, VPF, VPS), MP-Series™ (Bulletin MPL, MPM, MPF, MPS), Kinetix 6000M (Bulletin MDF), and TL-Series™ rotary motors.
Kinetix Motion Accessories Specifications Technical Data, publication KNX-TD004	Product specifications for Bulletin 2090 motor and interface cables, low-profile connector kits, drive power components, and other servo drive accessory items.
Kinetix Motion Control Selection Guide, publication KNX-SG001	Overview of Kinetix servo drives, motors, actuators, and motion accessories designed to help make initial decisions for the motion control products best suited for your system requirements.
Industrial Automation Wiring and Grounding Guidelines, publication 1770-4.1	Provides general guidelines for installing a Rockwell Automation industrial system.
Product Certifications website, rok.auto/certifications	Provides declarations of conformity, certificates, and other certification details.

You can view or download publications at <http://www.rockwellautomation.com/global/literature-library/overview.page>.

Rockwell Automation maintains current product environmental information on its website at <http://www.rockwellautomation.com/rockwellautomation/about-us/sustainability-ethics/product-environmental-compliance.page>.

Allen-Bradley, Kinetix, MP-Series, Rockwell Automation, Rockwell Software, and TL-Series are trademarks of Rockwell Automation, Inc. Trademarks not belonging to Rockwell Automation are property of their respective companies.

Rockwell Otomasyon Ticaret A.Ş., Kar Plaza İş Merkezi E Blok Kat:6 34752 İçerenköy, İstanbul, Tel: +90 (216) 5698400

www.rockwellautomation.com

Power, Control and Information Solutions Headquarters

Americas: Rockwell Automation, 1201 South Second Street, Milwaukee, WI 53204-2496 USA, Tel: (1) 414.382.2000, Fax: (1) 414.382.4444
Europe/Middle East/Africa: Rockwell Automation NV, Pegasus Park, De Kleetlaan 12a, 1831 Diegem, Belgium, Tel: (32) 2 663 0600, Fax: (32) 2 663 0640
Asia Pacific: Rockwell Automation, Level 14, Core F, Cyberport 3, 100 Cyberport Road, Hong Kong, Tel: (852) 2887 4788, Fax: (852) 2508 1846



PN-522270

Publication 2090-IN012E-EN-P - February 2019

Supersedes Publication 2090-IN012D-EN-P - July 2016

Copyright © 2019 Rockwell Automation, Inc. All rights reserved. Printed in the U.S.A.